

**AIRCRAFT AIR CONDITION AND HEATING SYSTEM**

**A THESIS SUBMITTED TO  
THE INSTITUTE OF GRADUATE PROGRAMS  
KARABUK UNIVERSITY**

**BY**

**AIUOB EZEEDEN SAHBOUN**

**IN PARTIAL FULFILMENT OF THE REQUIREMENTS FOR  
THE DEGREE OF MASTER OF SCIENCE IN  
DEPARTMENT OF ENERGY SYSTEMS ENGINEERING**

**January 2020**

I certify that in my opinion the thesis submitted by Aiuob Ezeeden SAHBOUN titled “AIRCRAFT AIR CONDITION AND HEATING SYSTEM” is fully adequate in scope and in quality as a thesis for the degree of Master of Science.

Prof. Dr. Mehmet ÖZKAYMAK  
Thesis Advisor, Department Of Energy Systems Engineering

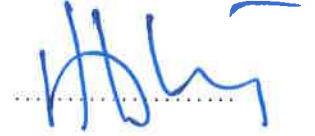

This thesis is accepted by the examining committee with a unanimous vote in the Department of Energy Systems Engineering as a master thesis. 02/January/2020

Examining Committee Members (Institutions)

Chairman : Prof. Dr. Kurtuluş BORAN (GÜ)

Member : Prof. Dr. Mehmet ÖZKAYMAK (KBÜ)

Member : Prof. Dr. H. Mehmet ŞAHİN (KBÜ)

Signature



The degree of Master of Science by the thesis submitted is approved by the Administrative Board of the Graduate School of Energy Systems Engineering, Karabük University.

Prof. Dr. Hasan SOLMAZ  
Head of Institute of Graduate Programs





*“I declare that all the information within this thesis has been gathered and presented in accordance with academic regulations and ethical principles and I have according to the requirements of these regulations and principles cited all those which do not originate in this work as well.”*

Aiuob Ezeeden SAHBOUN

## **ABSTRACT**

**M. Sc. Thesis**

### **AIRCRAFT AIR CONDITION AND HEATING SYSTEM**

**Aiuob Ezeeden SAHBOUN**

**Karabük University**

**Institute of Graduate Programs**

**Department of Energy Systems Engineering**

**Thesis Advisor:**

**Prof. Dr. Mehmet ÖZKAYMAK**

**January 2020, 75 pages**

This study focuses on aircraft heating systems. Combustion heater system is considered one of the internationally approved systems in the heating process used in small and medium-sized civil aircraft. It works independently of the main engines in the plane and also uses the same gasoline. Combustion heater systems are widely used to produce the main heating source for crew and passengers. All combustion heaters use a gasoline-air mixture for combustion energy. The kind of fuel used in aircraft is expensive and has some problems when in flight and under freezing temperatures. This mixture flow is fixed in all flight conditions, as the system does not have fuel flow control. Controlling the fuel-air mixture requires a special system, which could be a carburetor system or injection system.

Therefore, the system may be more complicated, require more maintenance and more defects in flight may occur. Thus, a combustion heating system needs to use a different source of energy to overcome the disadvantages of a gasoline system and allow the system to control the energy flow following less complicated method. Natural gas might be the best alternative energy to give a heating system advantages such as the same efficiency, lower cost, lower weight, greater safety, lower fuel consumption in addition to the cabin being able to control the gas flow according to passenger wishes and according to the ambient temperature. A gas control valve is used to adjust the gas flow, thereby allowing the system to change the aircraft temperature according to the altitude and the ambient temperature. According to the cost calculation between natural gas consumption and gasoline consumption, there is a difference in the cost. The freezing temperature of water is  $0^{\circ}\text{C}$ . The freezing temperature of gasoline is between  $-20^{\circ}\text{C}$  and  $-40^{\circ}\text{C}$ . Natural gas, however, has a very low freezing point of  $-256^{\circ}\text{C}$ , thereby enabling a heating system to function at all altitudes safely.

**Key Words** : Heating system, Aircraft, Natural gas, Cost.

**Science Code** : 92807

## **ÖZET**

**Yüksek Lisans Tezi**

### **UÇAK İKLİMLENDİRME VE ISITMA SİSTEMİ**

**Aiuob Ezeeden SAHBOUN**

**Karabük Üniversitesi**

**Lisansüstü Eğitim Enstitüsü**

**Enerji Sistemleri Mühendisliği Anabilim Dalı**

**Tez Danışmanı:**

**Prof. Dr. Mehmet ÖZKAYMAK**

**Ocak 2020, 75 sayfa**

Bu çalışma uçak ısıtma sistemlerine odaklanmaktadır. Yanmalı ısıtıcı sistemi, küçük ve orta ölçekli sivil uçaklarda kullanılan ısıtma sürecinde uluslararası onaylı sistemlerden biri olarak kabul edilir. Düzlemdeki ana motorlardan bağımsız olarak çalışır ve aynı benzini kullanır. Yanmalı ısıtıcı sistemleri, mürettebat ve yolcular için ana ısıtma kaynağını üretmek için yaygın olarak kullanılmaktadır. Tüm yanmalı ısıtıcılar yanma enerjisi için bir benzin-hava karışımı kullanır. Uçakta kullanılan yakıt türü pahalıdır ve uçuşta ve donma sıcaklıklarında bazı problemleri vardır. Sistemde yakıt akış kontrolü olmadığından, bu karışım akışı tüm uçuş koşullarında sabitlenir. Yakıt-hava karışımını kontrol etmek için bir karbüratör sistemi veya enjeksiyon sistemi olabilen özel bir sistem gerekir. Bu nedenle, sistem daha karmaşık olabilir, daha fazla bakım gerektirebilir ve uçuşta daha fazla arıza meydana gelebilir.

Bu nedenle, bir yanmalı ısıtma sistemi, bir benzin sisteminin dezavantajlarının üstesinden gelmek için farklı bir enerji kaynağı kullanmalı ve sistemin daha az karmaşık bir yöntemle enerji akışını kontrol etmesine izin vermelidir. Doğal gaz, kabine ilave olarak aynı verimliliği, daha düşük maliyeti, daha düşük ağırlığı, daha fazla güvenliği, daha düşük yakıt tüketimi gibi bir ısıtma sistemine avantaj sağlamak için en iyi alternatif enerji olabilir. ortam sıcaklığına getirin. Gaz akışını ayarlamak için bir gaz kontrol vanası kullanılır, böylece sistemin uçak sıcaklığını rakım ve ortam sıcaklığına göre değiştirmesine izin verilir. Doğal gaz tüketimi ile benzin tüketimi arasındaki maliyet hesaplamasına göre maliyette bir fark vardır. Suyun donma sıcaklığı 0 °C'dir. Benzinin donma sıcaklığı -20 °C ile -40 °C arasındadır. Bununla birlikte, doğal gazın 256 °C 'lik çok düşük bir donma noktası vardır, böylece bir ısıtma sisteminin tüm yüksekliklerde güvenli bir şekilde çalışmasını sağlar.

**Anahtar Kelimeler :** Isıtma Sistemi, Uçak, Doğalgaz, Maliyet.

**Bilim Kodu**

:

92807

## **ACKNOWLEDGMENT**

This report provides an explanation and it is written to provide background material and beneficial information for students. We hope students and readers benefit from our report and understand it.

I would like to express my sincere thanks to my advisors to Prof. Dr. Mehmet Özkaymak for their valuable comments and suggestions in the progress of this study. I would like to thank all my friends who have helped me in continuing this research.



## CONTENTS

	<b><u>Page</u></b>
APPROVAL .....	ii
ABSTRACT.....	iv
ÖZET .....	vi
ACKNOWLEDGMENT .....	viii
CONTENTS.....	ix
LIST OF FIGURES .....	xiii
LIST OF TABLES.....	xv
SYMBOLS AND ABBREVIATIONS INDEX .....	xvi
PART 1 .....	1
INTRODUCTION .....	1
PART 2 .....	2
LITERATURE STUDIES .....	2
2.1. NATURAL GAS USES IN HOUSE.....	2
2.1.1. Natural Gas .....	4
2.1.2. What is Propane Gas .....	5
2.1.3. How to Observe International Standards and Certification Numbers .....	5
2.1.4. Five-Step Decision-Making Process for Home Heating .....	5
2.1.5. Draft Proofing and Insulating .....	6
2.1.6. The Benefits of Preserving the Environment .....	8
2.2. HEATING SYSTEM-USING HYDRONIC .....	10
2.3. OTHER SYSTEMS USED .....	11
2.4. ELECTRICAL PANELS ARE A NEW OPTION IN HOMES.....	11
2.5. CONDUCTING HEAT TO DESIRED PLACES .....	12

	<u>Page</u>
2.6. TYPES OF EQUIPMENT FOUND IN THE HOT WATER HYDRONIC SYSTEM .....	13
2.7. THE BEST WAYS TO DISTRIBUTE HEAT .....	13
2.8. USE THE OUTDOORS TO RESET THE SYSTEM .....	15
2.9. HIGH-EFFICIENCY FURNACES AND BOILERS .....	15
2.9.1. Types of Condensing Ovens.....	15
2.9.2. Combustion Hermetically Sealed.....	15
2.9.2.1. Gas Furnaces.....	16
2.10. FANS WITH HIGH QUALITY AND PURITY .....	16
PART 3 .....	17
METHODOLOGY .....	17
3.1. ENVIRONMENTAL CONTROL SYSTEM IN AIRCRAFT.....	17
3.2. ENVIRONMENTAL CONTROL SYSTEM (ECS, INTERNAL).....	18
3.3. ENVIRONMENTAL PROTECTION SYSTEM (EPS, EXTERNAL).....	18
3.4. CABIN AIR CONDITIONING: .....	19
3.5. CABIN TEMPERATURE CONTROL SYSTEM.....	20
3.6. WHAT IS THE AIR-CONDITIONING SYSTEM USED IN AN AIRCRAFT .....	21
.....	
3.7. SUPPLY FROM THE MAIN AIR SYSTEM.....	22
3.8. AIR CYCLE AIR CONDITIONING SYSTEM OPERATION .....	23
3.9 VAPOR CYCLE AIR CONDITIONING .....	28
3.10. VAPOR CYCLE BASIC.....	29
2.11. MAIN PARTS OF THE AIR CONDITIONING SYSTEM FOR THE STEAM CYCLE .....	31
3.12. AIR CRAFT HEATING SYSTEMS.....	42
3.13. MITIGATE ICE ACCRETION ON WIND TURBINE BLADES .....	42
3.14. FUEL THERMAL SYSTEM.....	43
3.15. TANK TEMPERATURE INTEGRATION.....	43
3.16. WHAT IS THE AIRCRAFT HEATING SYSTEM TYPES .....	44
3.16.1 Exhaust Heating Systems .....	44

	<u>Page</u>
3.16.2. Electric Heating Systems.....	45
3.16.3. Heating with Bleed Air.....	47
3.16.4. Combustion Heater Systems.....	47
3.17. COMBUSTION HEATERS.....	47
3.18. THE MAIN PARTS OF EACH COMBUSTION HEATER.....	49
3.19. HOW TO PROVIDE VENTILATION AIR.....	50
3.20. HEATER FUEL SYSTEM.....	50
3.21. THERE ARE SEVERAL WAYS TO INSERT COMBUSTION FUEL INTO A COMBUSTION HEATER IN SEVERAL WAYS.....	52
3.22. DESCRIPTION AND HOW THE IGNITION SYSTEM WORKS.....	54
3.23. TYPES OF SPARK PLUGS.....	54
3.24. HOW TO CONTROL THE HEATING SYSTEM AND ITS DIVISIONS.....	56
3.25. INSTALLATION, MAINTENANCE AND ADJUSTMENT.....	58
3.25.1. Installation.....	58
3.25.2. Typical Inspection.....	58
3.26. SAFETY CONSIDERATIONS.....	59
3.27. NATURAL GAS.....	59
3.28. USE NATURAL GAS IN AIRCRAFT HEATING SYSTEM.....	61
3.29. HOW TO MEASURE NATURAL GAS.....	62
3.30. AVGAS HEATERS - FUEL CONSUMPTION.....	63
3.31. NATURAL GAS DEFINITION AND CALCULATION.....	63
3.32. HOW TO CALCULATE NATURAL GAS CONSUMPTION.....	63
3.33. EXACT GAS CONSUMPTION.....	64
3.34. BRITISH THERMAL UNIT (BTU) DEFINITION.....	64
3.35. HOW DO MEASURE NATURAL GAS.....	65
3.36. HOW NATURAL GAS PRESSURE CALCULATE.....	65
3.37. WHAT IS THE FORMULA THAT USED TO CALCULATE NATURAL GAS CONSUMED.....	65
3.38. GAS BURNER CONSUME FUEL BASED ON THEIR (BTU) OUTPUT.....	65
3.39. FUEL HEATING SYSTEM.....	66

	<b><u>Page</u></b>
CHAPTER 4 .....	70
CONCLUSION.....	70
REFERENCES .....	72
RESUME .....	75



## LIST OF FIGURES

	<b><u>Page</u></b>
Figure 2.1. Natural gas use .....	3
Figure 2.2. Natural gas.....	4
Figure 2.3. Natural gas resources.....	4
Figure 2.4. Boiler system.....	7
Figure 2.5. Preserving environment image.....	8
Figure 2.6. Air pressure system.....	9
Figure 2.7. Hydronic heating systems.....	10
Figure 2.8. Electric baseboards.....	11
Figure 2.9. Hot water system.....	13
Figure 2.10. Heat distribution balancing the heat.....	14
Figure 2.11. Gas furnaces.....	16
Figure 3.1. Cabin air condition.....	19
Figure 3.2. Air distribution system.....	20
Figure 3.3. Air cycle air conditioning.....	22
Figure 3.4. Pack valve.....	23
Figure 3.5. Primary heat exchanger.....	24
Figure 3.6. Refrigeration turbine unit.....	25
Figure 3.7. Water separator.....	26
Figure 3.8. Refrigeration bypass valve.....	27
Figure 3.9. Vapor cycle air conditioning.....	28
Figure 3.10. Refrigerant.....	31
Figure 3.11. Receiver dryer.....	33
Figure 3.12. Expansion valve.....	35
Figure 3.13. Evaporator.....	36
Figure 3.14. Compressor.....	38
Figure 3.15. Condenser.....	39
Figure 3.16. Service valves.....	40

	<u>Page</u>
Figure 3.17. Service valves.....	41
Figure 3.18. The simplest type of heating system .....	44
Figure 3.19. The simplest type of heating system .....	45
Figure 3.20. Electrical heating system.....	46
Figure 3.21. Electrical heating system wings. ....	46
Figure 3.22. Combustion heaters. ....	48
Figure 3.23. Combustion heaters. ....	50
Figure 3.24. Heater fuel system. ....	51
Figure 3.25. A spray nozzle. ....	53
Figure 3.26. A vapor wick. ....	53
Figure 3.27. Spark plugs. ....	55
Figure 3.28. Spark plugs. ....	55
Figure 3.29. Electrode sparkplug.....	55
Figure 3.30. Shielded electrode plugs.....	56
Figure 3.31. A single electrode.....	56
Figure 3.32. Cabin heat switch. ....	57
Figure 3.33. Thermostat.....	57
Figure 3.34. The relationship between gas and gasoline maximum efficiency with change in areas.....	68
Figure 3.35. Relationship between gas and gasoline minimum efficiency with change in areas .....	68

## LIST OF TABLES

	<b><u>Page</u></b>
Table 3.1. Table of comparative thermal values of fuels.....	66
Table 3.2. The relationship between gases consumed and cost with change in areas	67
Table 3.3. The relation between gasolines with change of areas.....	69



## SYMBOLS AND ABBREVIATIONS INDEX

### ABBREVIATIONS

ABU	: Auxiliary Power Unit
AC	: Alternating current
ATC	: Air Traffic Control
BTU	: British Thermal Unit
C	: Celsius
Ch4	: Pure Methane
CHP	: Combine Heat and Power
CO	: Combustion Operation
CRMU	: Customer Measured Unit
CSA	: Canadian Standards Association
Cu	: Cubic
DC	: Direct current
ECLSS	: Environmental Control Life Support System
ECS	: Environmental Control System
EPC	: Environmental Protection System
F	: Fahrenheit
Ft	: Feet
Hcf	: Increments
HP	: Horsepower
HR	: Preheat
J	: Joules
LCF	: Fuel Consumption in Feet
M	: Meter



MCF	: Million Cubic Feet
ME	: Minimum Energy
Mj	: Millijoules
PPH	: Power Per Hour
PSI	: Pressure Scale Indicator
R	: Refrigerant
RH	: Right Hand
SE	: Second Engine
T	: Temperature
TT	: Turbine Temperature
UL	: Underwriters Laboratories
ULC	: Underwriters Laboratories Canada
US	: United States
USG	: Used Speed Gasoline

## **PART 1**

### **INTRODUCTION**

In-flight the air-condition and heating system is a major concern in aircraft safety to avoid accident or crash. It remains consequently a design and certification challenge for aircraft manufacturers. Once aircraft is moving from the ground to the flight the temperature of the atmosphere is not fixed. There is a relation between the altitude and the ambient temperature which when altitude increase temperature decrease. Air-condition system is almost use on the ground or in the initial flying, after that the heating system will start and continue with aircraft until the end of the travel. The aircraft can indeed degrade rapidly when flying in icing conditions without heating system because the temperature below freezing point. There are many kinds of heating system used in different aircraft models. Combustion heater system is one of environmental systems, which are those aircraft systems used to make the interior environment of the aircraft comfortable and/or habitable for human beings. Combustion heaters are similar in description and mode of operation and you may find some differences in modern systems in terms of safety units and heater shutdown keys in dangerous conditions. Aircraft manufacturing companies are responsible for making the combustion heater, developing it and providing it with the necessary spare parts. Depending on the type of aircraft and altitude of operation. This may involve only supplying a flow of fresh air through the cabin by adjusted for crew and passenger comfort some method of heating or cooling the cabin interior is required. This work presents the combustion heater system that used in the light and medium aircraft size, in this heater system air fuel mixture used to produce heat. Once the temperature is below freezing point, the air fuel mixture facing many problems, especially fuel (gasoline). The fuel passing during fuel lines from main fuel tank to heater and this fuel lines are exposed to below freezing temperature, so the little amount of water or water vapor it causes seriously problem.

## **PART 2**

### **LITERATURE STUDIES**

This study focus on Air Craft heating system that is use natural gas instead of usual fuel such as kerosene or gasoline to produce heat energy.

Since I could not find previous studies that is includes this theory I will use the house and car heating systems to explain how the natural gas works.

#### **2.1. NATURAL GAS USES IN HOUSE**

60 percent of the heat energy used is usually to heat the houses from the inside. Therefore, the owner of the house must make a smart decision about heating so that it can reduce the cost and energy used to make the house at an appropriate temperature with the lowest costs. Taking the time to make the best choice for a home heater is very important because you will use it for a long time. The use of modern or advanced heating device for long periods deserves you to seriously investigate the available goods in order to achieve the best choice of products available for your home use Figure 2.1. When there is a wide variety of good equipment, it is difficult to compare the options available to a grandfather. Whether you are choosing a new system, changing the old system with a new one, or renewing the existing one, you will get help in choosing the right decision and a good choice [2].

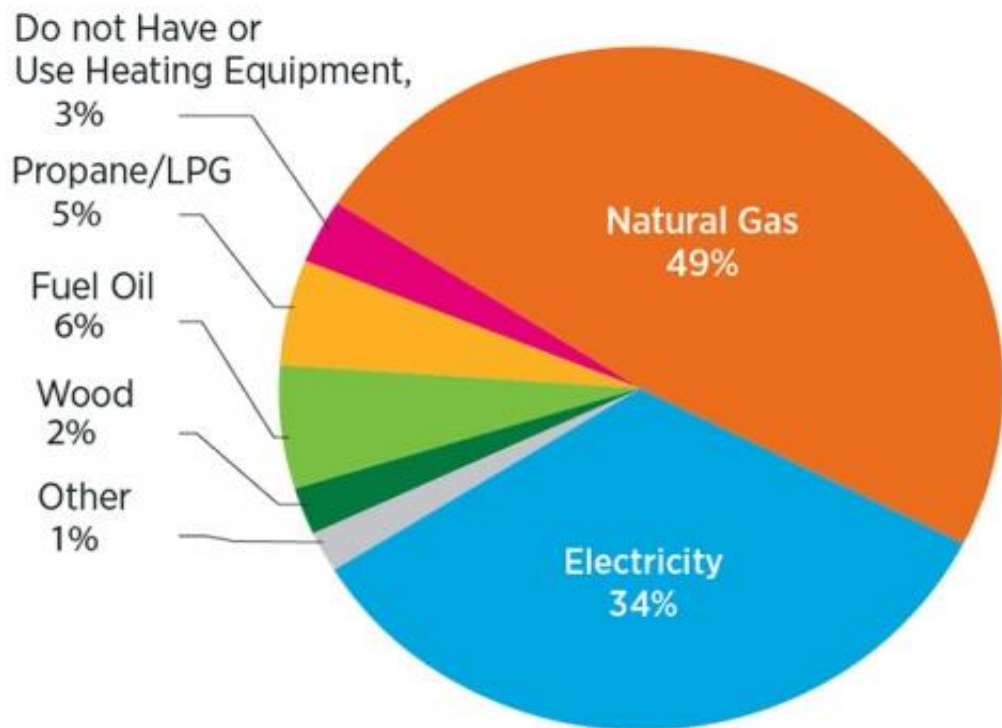

Figure 2.1. Natural gas use [1].

The concept of energy efficiency used is measured by the amount of heat energy generated by burning fuel to convert it to heat. All methods used in the burning of fuel such as oil, natural gas, propane and wood have some losses in thermal energy and also when operating the device or stop. It takes some time until the temperature rises and if the process of fuel incomplete occurs loss of energy and heat. All gases resulting from the combustion process is disposed of by flue. The efficiency of the heating system is measured by calculating the fixed efficiency after operating the heating device for long periods suitable to obtain the appropriate operating temperatures. This standard scale is used to adjust the heating system and calculate the efficiency of the device. However, we will not get the required level in calculating the efficiency when winter Figure 2.2.

### 2.1.1. Natural Gas

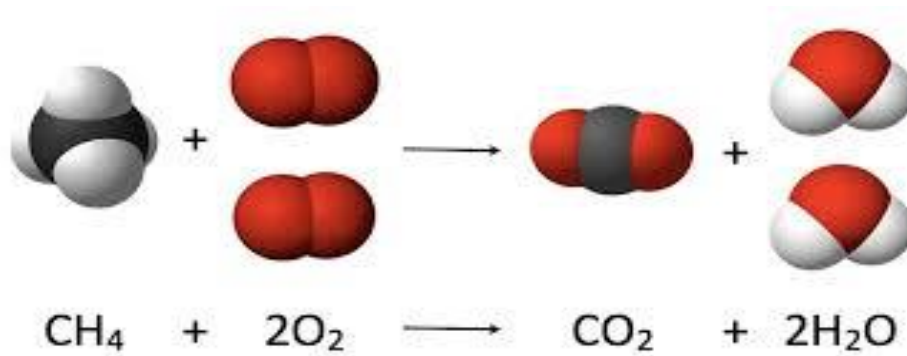

Figure 2.2. Natural gas [2].

The use of natural gas energy is measured in cubic meters or cubic feet. Each house has a counter that registers the units used. If you use invoices for units that are not in your counter, you can calculate the units after converted:

Multiply cubic feet by 0.028 to get cubic meters

One cubic meter of natural gas contains approximately 37.5 MJ (35 500 Btu/m<sup>3</sup>) of energy.

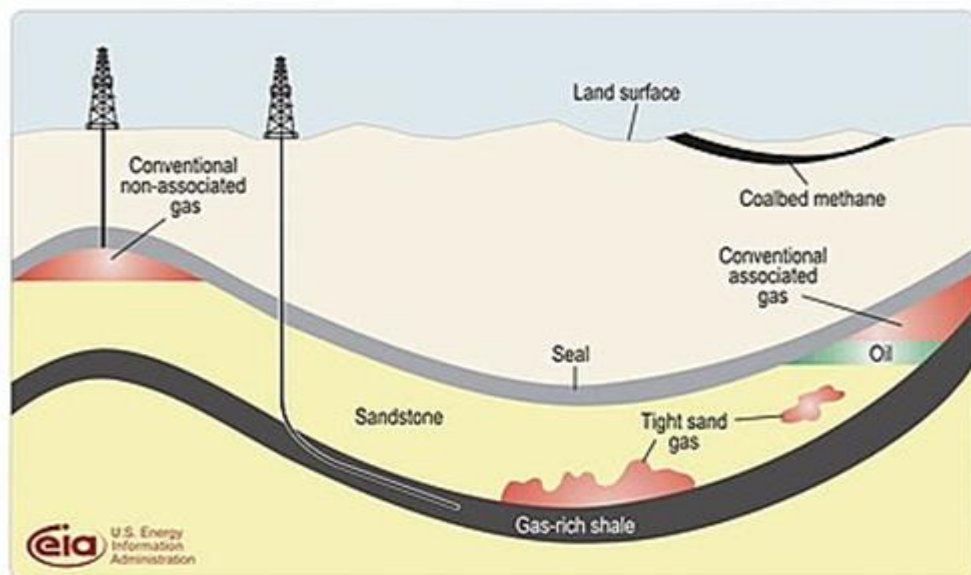

Figure 2.3. Natural gas resources [28].

### **2.1.2. What is Propane Gas**

In most countries a liter is used to measure gas consumption, where one liter of propane contains MJ (91 000 Btu/US gallon) of energy. From a general perspective, all applications and comments on propane apply to natural gas, with some differences in efficiency and use from one system to another.

Natural gas has a higher percentage of hydrogen than propane and therefore the higher proportion of hydrogen found in natural gas is treated. Because of the low level of hydrogen contained in the propane gas composition, it is difficult to intensify the combustion products (Figure 3).

### **2.1.3. How to Observe International Standards and Certification Numbers**

Only devices that comply with safety standards for sale in Canada and which have been developed by the Canadian Standards Association are allowed (CSA). Compliance must be established by an independent and accredited body by the Canadian Standards Board, such as CSA International, Underwriters Laboratories Inc. (UL), Underwriters' Laboratories of Canada (ULC), Intertek Testing Services NA Ltd. Furnaces, and boilers used to burn natural gas or propane gas shall be of a level of efficiency equivalent to the Federal Energy Regulations. There are different ways to increase the efficiency of the heating device. You can raise some of the efficiencies in the heater yourself, but you should hire maintenance personnel who hold licenses from maintenance companies. When considering a home heating system, you should take the time to make improvements and the water heater should be considered.

### **2.1.4. Five-Step Decision-Making Process for Home Heating**

When the home heating system and the water heater gets some modifications and upgrades. It will have a good effect on the environment and the financial cost. Since the size and location of the house has a direct impact on the heating requirements. If

you understand how you can benefit from the available options you will get the desired benefits. The five steps that will help you to make your home heating system selection are explained in detail as well as choosing the right heating device for your home requirement. If you think about getting an appraisal for the heating system in your home from Eco Energy The evaluation will be detailed for energy efficiency and how to improve your energy performance. To obtain a home that is less energy efficient and more comfortable, you should use this information on energy enhancements integrated with the cost system to renew your systems.

### **2.1.5. Draft Proofing and Insulating**

Step-1 In the event that large quantities of air escape from the house or cold air from entering the outside, the new advanced heating system will not be able to reduce the heating costs because the house needs to prevent air leakage.

It is best to check the house before changing or buying a new heating system as the air leak makes reducing energy loss and financial cost unavailable under these conditions. If you call a specialist or do the work yourself, find all you need in this publication, including the amount of optimal isolation with a shortened time and costs.

- Good air insulation provides a lot of benefits.
- You get heating at the lowest cost and the fastest time.
- You get a comfortable life due to low cost and maintenance of roofs and walls.
- You get a less heated house in the summer.
- You get the lowest levels of humidity throughout the year.

The proportion of dry air inside the house may increase due to the leakage of air inside the house or vice versa during the winter humidity in the cold air in the air more than inside the house and if the air is heated inside the house will decrease the humidity inside the house too much. One of the best solutions available to solve the problem of dehydration inside the bit is the use of moisture device and spray has

been isolated well, the house does not need to use a moisture device because the moisture resulting from the use of hot water in the house is enough to produce adequate humidity for the whole house.

Increased humidity inside the house due to good insulation and tight may affect the quality of the air One of the best ways to get rid of this problem with the lack of hot air escape is to use an electric fan to draw fresh air inside the house while maintaining the required temperature. If you have a desire to buy a new house or build a house it must be according to the standard to the R-2000\* Standard or the ENERGY STAR® for New Homes standard. In order to obtain a low cost of heating, it is necessary to observe the modern standards in the construction of new houses where the proportion of insulation is good with the use of a high efficiency ventilation system. and in this way will reduce the rate of energy drainage by 30 per cent compared to the designs of old construction.

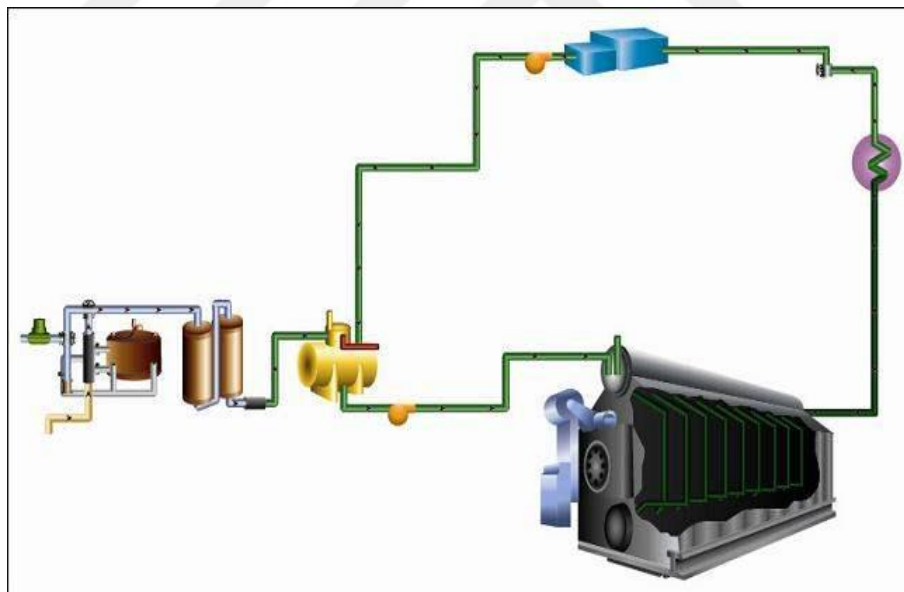

Figure 2.4. Boiler system [25].

Step 2. You choose a source of energy, the second step is the type of energy used in the heating system. You may choose natural gas, propane electricity and fuel oil as these are traditional energy types. Add to that the use of solar energy and is a source of renewable energy, but expensive. All natural gas or propane equipment is part of



this study, which recommends the use of natural gas instead of propane gas because it is lower in price and does not require traditional local tanks in storage.

### 2.1.6. The Benefits of Preserving the Environment



Figure 2.5. Preserving environment image [1].

There are several major negative impacts on the environment that affect our lives, including the consumption of kerosene and propane gas, as well as new exploratory processes to extract fossil fuels and leaks that occur during transportation of liquid energy and gas leaks that lead to acid rain and smog. Solar energy is the least energy that adversely affects the environment and all other types of energy have different effects in terms of temperatures, and gases on the environment and there is no safe type for 100 percent the energy used in the domestic heating system can affect the environment. Dimensions of roads and power plants need to burn a large amount of fuel that emits harmful gases to the environment. The type and quantity of fuel used determines the amount of direct impact on the environment and the selection of the right time to minimize the harmful impact on the environment, modern equipment and the least harmful type of fuel should be selected for use in the heating system. When you run the household lighting device, the amount of natural gas propane or liquid fuel that emits pollutant gases into the surrounding environment and the use of power plants have an effect on the environment.

In short, getting a final solution is not easy, but your choice of modern heating system and less fuel impact on the environment contributes to a real help to maintain the public environment. The installation of an efficient ventilation system and good insulation quantity of the house makes fuel consumption less.

### Step 3. Selecting or improving your heat distribution system

Some gas heating systems use compressed air, but hydrogen systems use hot water in the heating process. These systems consist of furnace, distribution pipes, heat exchange system, and regulator.

### Step 4-5 Forced-air systems

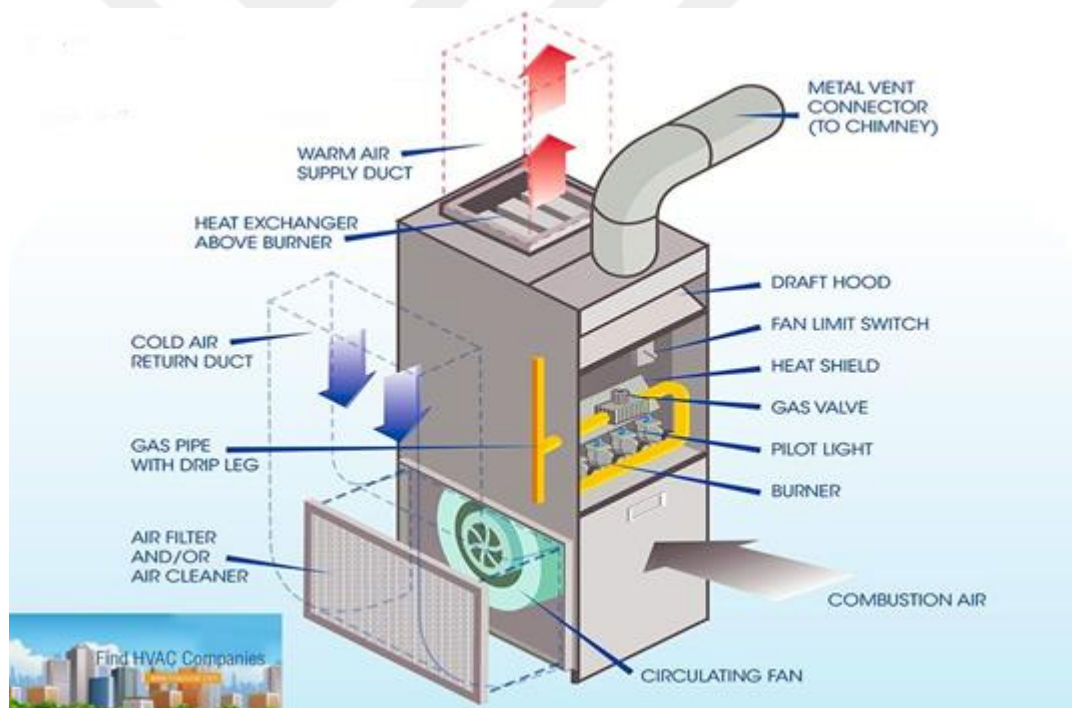

Figure 2.6. Air pressure system [25].

The best type of concentrated heating used in Canada is the air pressure system and uses the convection oven to produce heat and has the ability to quickly produce heat and filter the air and maintain the appropriate humidity And appropriate distribution of heat inside the house. When using a fan of good quality and the engine has a

strong capacity makes the heating system effective in the circulation of air inside and outside the house when adjusting the thermostat to a lower temperature at night makes energy saving possible. The type used to compress the air in the heating process has some disadvantages, for example, the powerful propeller motor causes In not adjust the amount of hot air flow on the house. The amount and temperature coming out of the system is similar to the breezes of summer and may be high temperatures sometimes. When distributing hot air in the airlines you get some disadvantages, for example, the transfer of noise from outside the house to the inside and the transfer of food odors to all rooms and the introduction of dust into the house. It is best to consult a specialist to help solve these problems.

## 2.2. HEATING SYSTEM-USING HYDRONIC

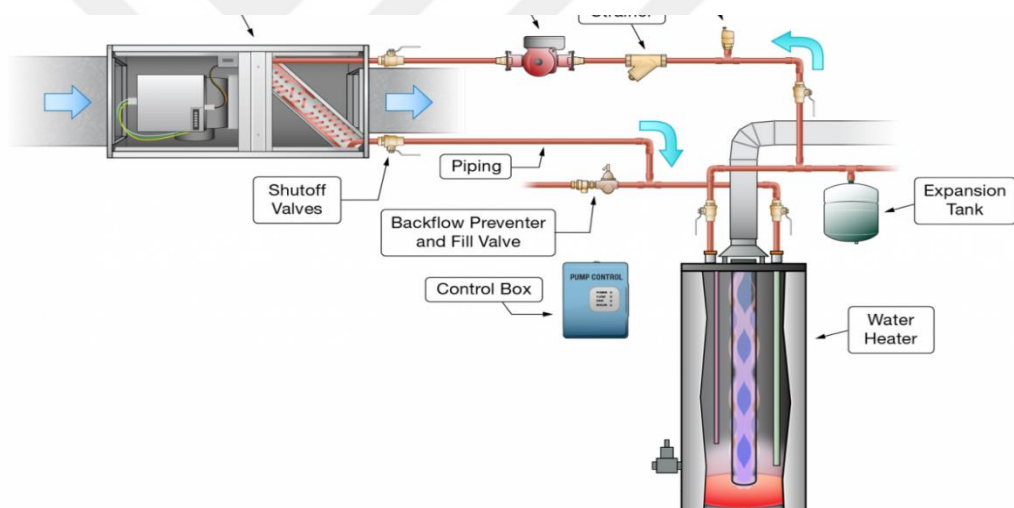

Figure 2.7. Hydronic heating systems [25].

Electricity is used to heat the water in the hydrogen heating system with the hot water boiler as an approved source of heat and then the heat is distributed through the water pipes represented in the walls of the entire house. Then return back to the water boiler to complete the cycle. In steam or hot water heating systems contain large water boilers and heavy wrought iron pipes these systems are considered old and are still used in some old houses. Modern systems after heating water are distributed in plastic pipes or copper smaller and less expensive. [Figure 7] Recent research has proven CSA approved the most use in water heating and distribution

systems in the home and some studies have proven that it is safe to deliver drinking water.

### **2.3. OTHER SYSTEMS USED**

There are some types using natural gas in the home heating system works individually or uniformly with other electric heaters with pipes heat exchange system and control system. In some homes that use small heaters and all areas are limited without the need to use the main heating system which is high cost and this reduces energy consumption and pollution. Radiant heat systems are thin tubes that pass through water to hot water and are buried underground or on the bottom of the wall.

The heat is distributed throughout the house by underground pipes by pumping hot water at 40 degrees. If the carpet is thick, the heating system becomes inefficient and the installation of this system is expensive and does not provide energy.

However, the installation of some modern high-cost flooring offers convenient benefits to the user while reducing the cost by adjusting the thermostat to low temperatures [10].

### **2.4. ELECTRICAL PANELS ARE A NEW OPTION IN HOMES**



Figure 2.8. Electric baseboards [25].

The use of electric panels in some homes is expensive and when thinking about changing the old system financial cost is the biggest obstacle and systems that use

hot air in the process of heating can be renewed at a lower cost compared to the electrical system Figure 2.8.

In these questions, you may find the final answer that helps you in your choice of heating system:

- Compare the system you use compared to other systems financially
- Percentage of compatibility between the energy used and the heating system
- Your satisfaction with the heating temperature

Do you choose a central ventilation system or an air circulation adjustment device?

Are installation and maintenance services available for your system?

### **Step 5. How to choose a heating system**

Before choosing your energy sources, you should consider the alternatives available in terms of thermal efficiency and the equipment used, as well as in the case of changing the old system completely or refurbished

The use of a high quality fan helps to distribute hot air constantly throughout the house and if the fan used is of poor quality, the cost of electricity increases

The use of a high-quality DC motor instead of AC motors for prolonged periods makes saving a large amount of energy possible with comfortable and moderate heat

## **2.5. CONDUCTING HEAT TO DESIRED PLACES**

The uneven heat distribution leads to the lack of distribution of heating to some rooms, as well as bedrooms located on the upper floor

- The escape of some hot air in the joints found in the delivery pipes
- The presence of some places outside the scope of the system and pass through the heating pipes, which leads to the loss of a lot of heat
- You should also check the channels and lines tightly closed



The escape of hot air to the outside can be significant if there is a leak in the pipes carrying hot air in the outer walls. In case you are unable to solve the problems of hot air distribution or the escape of air through the connecting pipes, you should contact the qualified employee to reset the system, adjust the fan to the appropriate degree and thermostat, and put appropriate ventilation for the home.

## 2.6. TYPES OF EQUIPMENT FOUND IN THE HOT WATER HYDRONIC SYSTEM

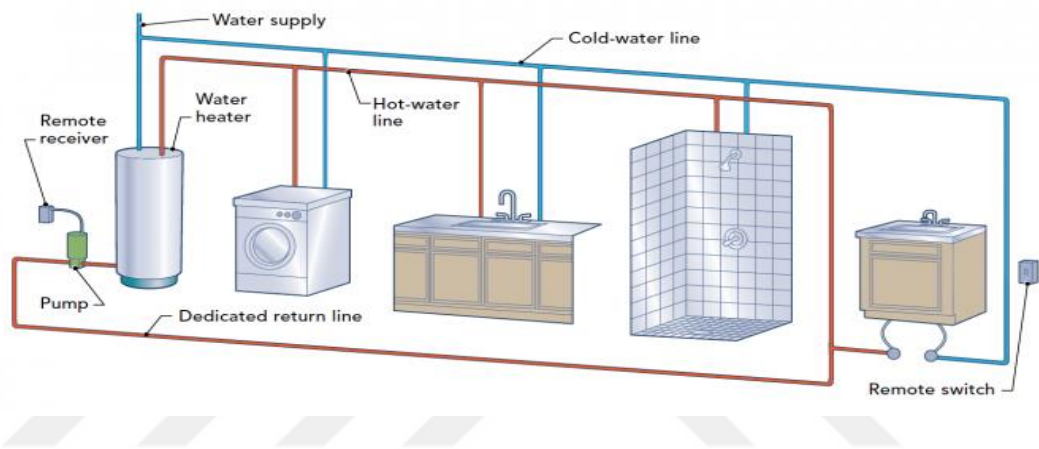

Figure 2.9. Hot water system [28].

The basic components of all hydrogen heating systems for heating water through special pipes inside the house (Figure 2.9):

- Thermal system produces heat by burning gas.
- Slicks in rooms such as metal panels or radiators are usually installed on the roofs of walls.
- The presence of a high-quality small pump works to pump water through pipes from heat sources to the rooms of the house.

## 2.7. THE BEST WAYS TO DISTRIBUTE HEAT

The new high-quality systems work by pumping water or hot air with a national fan compared to the old systems that operate the system of gravity in the distribution of heat in the heating system. Slow air movement in the heating system may lead to a

marked change in house temperature. When using old systems, defects in the distribution of heat in all floors of the house are obvious and cannot when the boiler is in the lower floor; the conduction of gravity heat has many problems and defects. To overcome these defects, modern systems using a fan or pump should be used to increase the pressure in the system and replace the old tank with a compact and compact tank In case of a decision to modernize the system, specialized offices should be consulted (Figure 2.10).

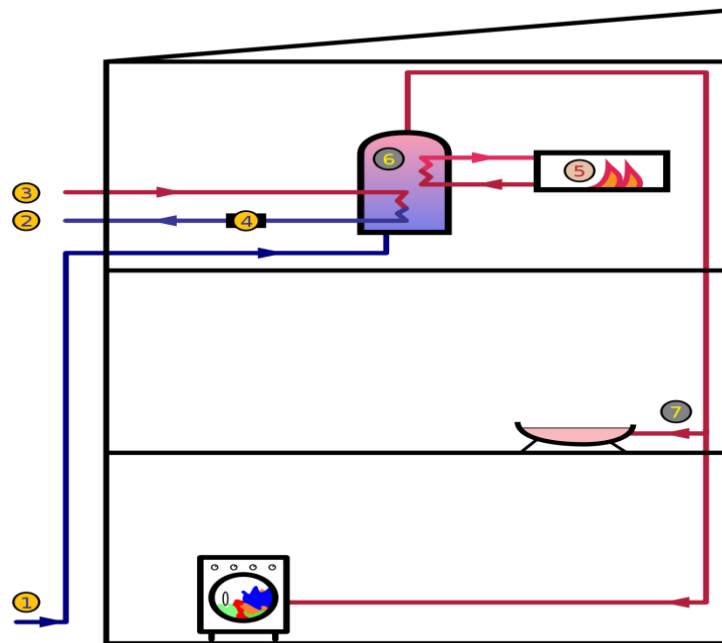

Figure 2.10. Heat distribution [28].

The distribution of heat in all areas of the house in a balanced manner is important with the compressed air hydronic heating system To control the temperature there is a manual switch installed with the radiation unit and the panel unit to control the amount of water passing through the heating pipes The control switch is used to change the temperature in all rooms according to the consumer desire while maintaining the heat balance. The thermostat uses a heat radiator as a method to automatically change the outgoing temperatures, in systems using the chain-loop system, the radiator does not have a control switch because water must return to the boiler across all units.

## **2.8. USE THE OUTDOORS TO RESET THE SYSTEM**

Many thermal heating systems are designed to use hot water at 60 ° C and adjusting the outdoor control unit adjusts the flow rate of water compared to the outside air temperature. If the outside air temperature is high, the amount of energy burning inside the boiler will be reduced to reduce the temperature of the house compared to the outdoor temperature. If old boilers are used. You may be at risk of corrosion or thermal shock if the return water temperature is below the system design temperature. Consult your plumbing expert or heating system designers if your system is designed to handle low temperatures.

## **2.9. HIGH-EFFICIENCY FURNACES AND BOILERS**

Compared to the thermal systems used, the gas condenser system is the most efficient in reducing energy use between 90 to 98 per cent and requires the use of thermal panels with high efficiency of not less than 90 per cent.

### **2.9.1. Types of Condensing Ovens**

- Avoid old heating systems for long periods of poor ventilation
- Small energy-saving buildings with best fit

### **2.9.2. Combustion Hermetically Sealed**

Fresh airflows directly from outside into the closed combustion system and air is excluded from the house in combustion processes or gas system pressure. This method is useful because it reduces or eliminates the possibility of sudden pressure reduction as well as reduces the problem of corrosion by withdrawing gases from the home such as taking gases out of the laundry room and gases from cooking room. In modern heating systems, there are two pipes to introduce fresh air and the second to remove gases from inside the house while the old systems use a single-tube system.



### 2.9.2.1. Gas Furnaces

Corrosion-resistant materials such as steel are used in the heat exchange unit of the condensing furnace system. The heat inside the combustion units is extracted using water to condense water vapor. A plastic pipe can replace the chimney unit because the degree of gases is not high and this reduces the installation costs of the system (Figure 2.11).



Figure 2.11. Gas furnaces [31].

Houses operating at low temperatures for return water contain the following

- Reflective flooring surfaces
- Hot water complex

### 2.10. FANS WITH HIGH QUALITY AND PURITY

When contracted with companies with high quality products, they provide high quality and efficient fan motors for prolonged use without problems and less maintenance.

## **PART 3**

### **METHODOLOGY**

#### **3.1. ENVIRONMENTAL CONTROL SYSTEM IN AIRCRAFT**

The first task of the cooling system is to maintain the temperature and atmospheric pressure as it is on the surface of the earth to keep (goods, living matter, and people) i.e., keeping temperature, the environmental control system (ECS) refers to equipment in pressure, and composition, within acceptable limits. (The term ECLSS, for environmental control and life support system, is also used to make the latter explicit). Aerospace engineering (aeronautical and space) is high-tech transport engineering, involving vehicles, infrastructures and payloads. Aviation refers to activities that involving man-made flying devices (manned and unmanned aircraft), and the people, organizations, and regulatory bodies involved in their use.

- Vehicles (aircraft and spacecraft; aircraft=aerostats (balloons and airships) and aerodynes (airplanes and rotorcraft), manned or unmanned).
- Structure (frame): fuselage, wings, and appendices.
- Propulsion: engines and propellers

Energy systems for propulsion and control movement:

Fuel, mechanical, hydraulic, pneumatic, and electrical systems

- Flight control systems: sensors and actuators, electronic systems (avionics)
- Communications: air traffic control (ATC), radio-navigation, intercoms
- Start and stop systems (for engines and other systems): undercarriage (landing gear), APU, ground starter, ram air turbine [3].

### **3.2. ENVIRONMENTAL CONTROL SYSTEM (ECS, INTERNAL)**

- Cabin air conditioning such as: pressure, temperature, ventilation, humidity (e. g. windows defogging), and fire protection system.
- Water lines and sanitation: Flexible hoses are used, and cold water pipes must incorporate thermal sensors and electrical strip heaters to guarantee  $T_w > 0\text{ }^\circ\text{C}$  even with  $T_{ext} = -40\text{ }^\circ\text{C}$ , in spite of the hose being resistant to water freezing. Hot water use electrical system to increase heat until to  $T_{max} = 50\text{ }^\circ\text{C}$ .
- Food and water, solid waste
- Others: center and wings fuel tanks energization, cabin furniture ergonomics, noise lighting, entertainment

### **3.3. ENVIRONMENTAL PROTECTION SYSTEM (EPS, EXTERNAL)**

- Against high temperatures of weather (rarely against cryogenic temperatures)
- Against high-speed winds or turbulences.
- Against cool water and ice.
- Against radio radiations and electrical shock.
- Others: against biological attack (from microorganisms to beasts) either through openings or by impact in flight.
- Infrastructures: base, tracks, navigation aids, telecommunications, operations, and payload management.

### 3.4. CABIN AIR CONDITIONING:

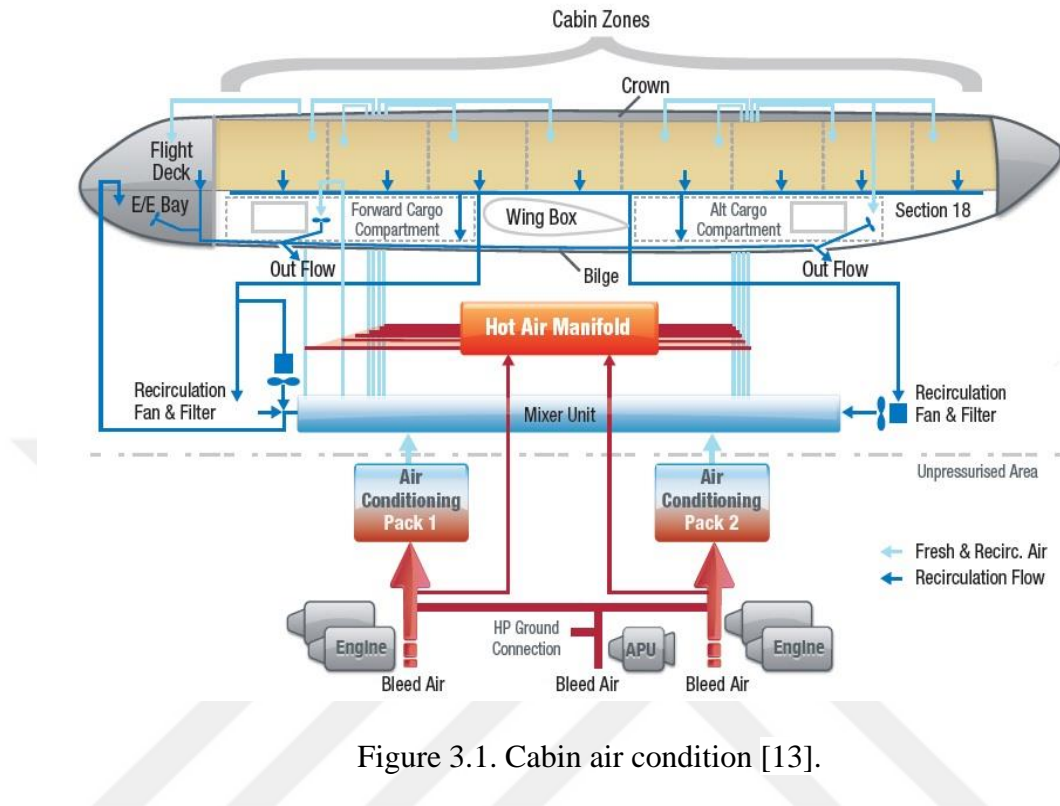

Figure 3.1. Cabin air condition [13].

Cabin air conditioning system must provide comfort conditions in all flight altitude (i. e. some  $22 \pm 2$  °C, 90. 100 kPa, and 50 70 % RH). Within a closed body (the cabin), under all flight conditions ( $-60. +50$  °C, 10. . 100 kPa, 0. . 100 % RH, ozone, etc.), i e. it must provide enough ventilation, pressurization, heating, cooling, humidification, dehumidification (demisting), and disinfection. One may split air conditioning factors in physical, chemical, and biological. Besides, cabin air monitoring provides the basic smoke detection means for fire warning. Air conditioning system is the second power-consuming system, after propulsion power. Conditioned air enters the body of aircraft from distribution lines by wall-floor and ceiling grilles and directional outlets above the seats, and goes out through other grilles and collecting ducts [Fig. 12]. About half or more of this exiting air is exhausted from the airplane through an outflow valve in the underside of the cabin, and the other half is drawn by fans through special filters (for trapping microscopic particles, bacteria and viruses) and then recirculate. On some flight lines, there is no recirculation, to have more margins for avionics system and wires cooling [8].

### 3.5. CABIN TEMPERATURE CONTROL SYSTEM

Most cabin temperature control systems are working in a similar manner. Temperature is monitored in the cabin, cockpit, conditioned air ducts, and distribution air ducts. These values are input into a temperature controller, or temperature control regulator, normally located in the electronics bay. Temperature selector located in the cockpit can be adjusted to input the desired air temperature. The temperature controller switch compares the real temperature signals received from the different sensors with the desired air temperature input. Electrical circuitry for the selected mode processes these input signals. An output signal is sent to different valves in the air cycle air conditioning system. This valve has different names depending on the aircraft manufacturer design and shape of the environmental control systems (i. e. , mixing valve, temperature control valve, and trim air valve). It mixes warm bleed air that bypassed the air cycle cooling process with the cold air produced by it. By modulating the valve in response to the signal from the temperature controller, air of the selected temperature is sent to the cabin through the air distribution system as (figure 3.2).

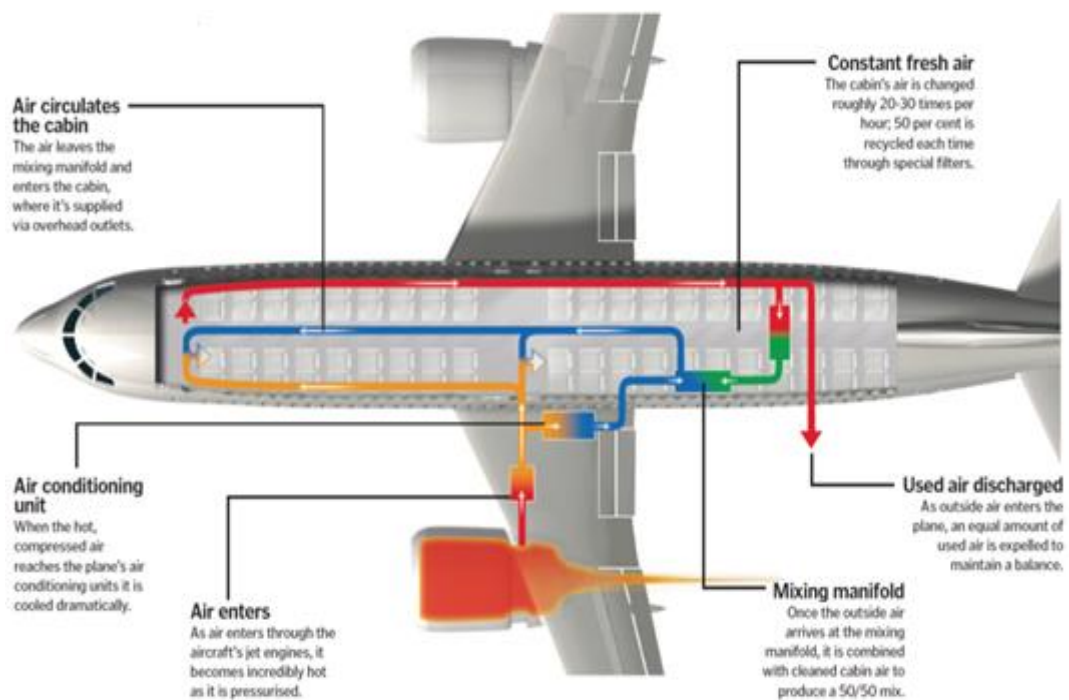

Figure 3.2. Air distribution system [14].

### **3.6. WHAT IS THE AIR-CONDITIONING SYSTEM USED IN AN AIRCRAFT**

There are two kinds of air condition systems are used on aircraft. Air cycle air conditioning is used on all turbine-powered aircraft. It makes use of engine bleed air or APU pneumatic air during the conditioning process. Vapor cycle air conditioning systems are often used on reciprocating aircraft. This type system is similar to that used in houses and automobiles. Note that some turbine-powered aircraft also use vapor cycle air conditioning.

#### **3.6.1. Air Cycle Air Conditioning**

How does air cycle system work on aircraft? Air cycle refrigeration system works on the reverse Brayton or Joule cycle. Ram air is compressed and then heat removed from the air, this air is then expanded to a lower temperature as we needed than before it was compressed. Action must be taken out of the air during the expansion situation otherwise, the problem would increase. Action is taken out of the compressed air by an expansion turbine, which removes movement energy as the blades of the turbine are driven round by the expanding air. This work can be usefully done to run other systems, such as generators or fans. Often, though, it is used to power a directly connected (bootstrap) compressor, which rotate the compressed (hot) side pressure further without added external energy input, essentially recycling the moving energy removed from the expanding air to compress the high pressure air further. The increase in air pressure on the hot side of turbine further elevates the temperature and makes the air cycle system produce more useable heat energy (at a higher temperature). The cold air after the turbine can be used as a refrigerant either directly in an open system to the body, or indirectly by means of heat exchanger devices in a closed system. The efficiency of the air cycle system is limited to a great extent by the efficiencies of compression and expansion, as well as those of the heat exchangers employed as (Figure 3.3).

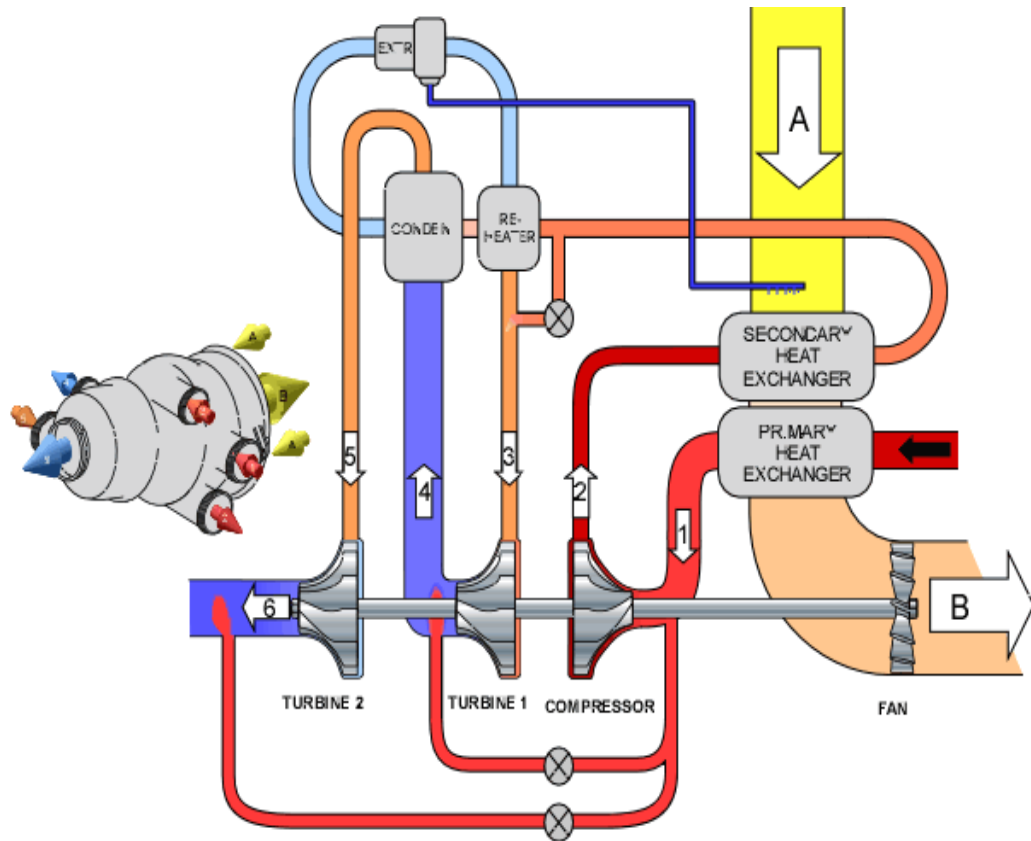

Figure 3.3. Air cycle air conditioning [11].

### 3.7. SUPPLY FROM THE MAIN AIR SYSTEM

The air cooling system is supplied with fresh air from the outside by the air system. In contrast, the air system in the aircraft is supplied with air by jet engines either from the air compressor section or auxiliary engine located at the rear of the aircraft ABU. When the aircraft is on the ground and the engines are stopped the aircraft is provided with sufficient and necessary air for the cooling system by means of openings in the body of the aircraft. In the case of normal flight, the air conditioning and cooling system is supplied with the necessary air directly from the motors of the compressor section through a main distributor, pipes and special valves some of this air is used in the defrosting system. Critical ice prevention and hydraulic pressure system.

## 3.8. AIR CYCLE AIR CONDITIONING SYSTEM OPERATION

### 3.8.1. Pack Valve

The pack valve (regulator valve) is the valve that regulates bleed airflow from the pneumatic manifold line into the air cycle air conditioning system. The pilot controls the switch from the air conditioning panel in the cockpit. Many pack valves are electrically controlled and pneumatically operated. Also known in aircraft as the supply shutoff valve, the pack valve opens, closes, and adjusts or control, modulates to allow the air cycle air conditioning system to be supplied with a desired volume of hot, pressurized air. [Figure 15] When an over heat or other abnormal condition requires that the air conditioning system package be shut down all the system, a signal is sent to the pack valve to close.

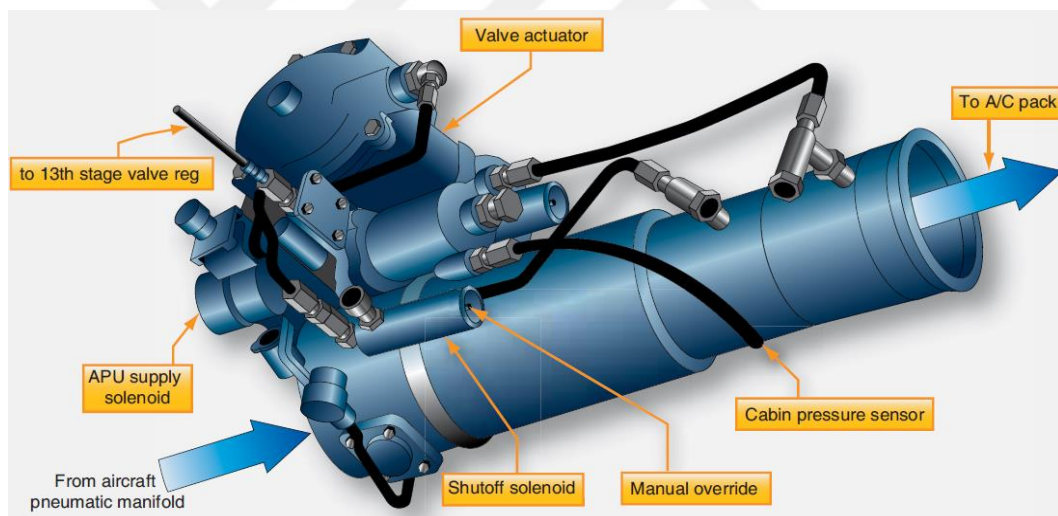

Figure 3.4. Pack valve [8].

### 3.8.2. Bleed Air Bypass

A means for bypassing some of the pneumatic air supplied to the air cycle air conditioning system through the system lines is present on all aircraft kinds. This hot bypassed air must be mixed carefully with the cold air produced by the air cycle system so the air delivered to the cockpit and cabin is a comfortable temperature. It continuously controls the airflow of bypassed air and rams air to be cooled to meet



the requirements of the auto temperature controller switch. It can also be moved to manual control with the cabin temperature selector switch in manual mode. Other air cycle systems may refer to the valve that controls the air bypassed around the air cycle cooling system as a temperature control valve, trim air pressure regulating valve, or something similar.

### 3.8.2. Primary Heat Exchanger

The warm air dedicated to pass through the air cycle system air condition first passes during primary heat exchanger device. It works similarly to the radiator device in an automobile. A controlled airflow of ram air is passed over and through the exchanger, which reduces the air temperature inside the system. [Figure 16] A fan draws air through the ram air duct when the aircraft is on the ground so that the heat exchange is possible when the aircraft is stationary or engines off. During flight, ram air doors are modulated to increase or decrease ram airflow to the exchanger part according to the situation of the wing flaps. Through slow flight, when the flaps are extended at low speed, the doors are open. At higher speeds, with the flaps retracted, the doors move toward the closed position decreasing the amount of ram air to the exchanger. Similar operation is accomplished with a valve on smaller aircraft. (Figure 3.5).

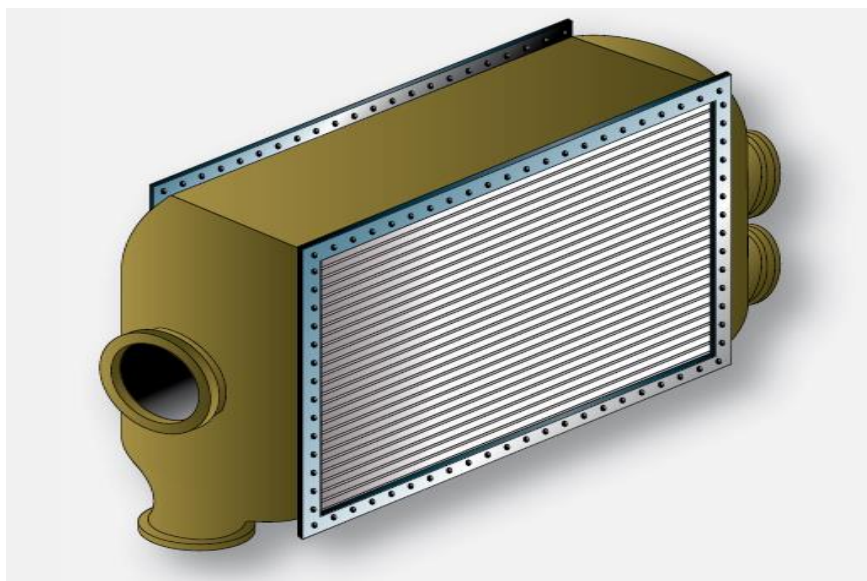

Figure 3.5. Primary heat exchanger [8].

The turbine part is the main part of each air conditioning system and is known as the air circulation machine. The main parts of the air conditioning system are the turbine part and the compressor part and are fixed on a uniform shaft. The air temperature increases with increasing pressure, then the temperature is reduced using the primary heat exchanger, and there is a secondary heat exchanger in the main airway to reduce more heat. Heat exchange with ram air is easily carried out and the cooled air flows under pressure into the body of the aircraft. The air is transferred to the turbine side with the inclination angle of the blades which increases the airflow and this increases the turbine rotation capacity, When the air reaches the outlet it expands and the temperature increases Air is used in the circulation of turbines, which leads to loss of energy and then the air expands at the outlet of the turbines and the temperature drops to freezing point (Figure 3.6).

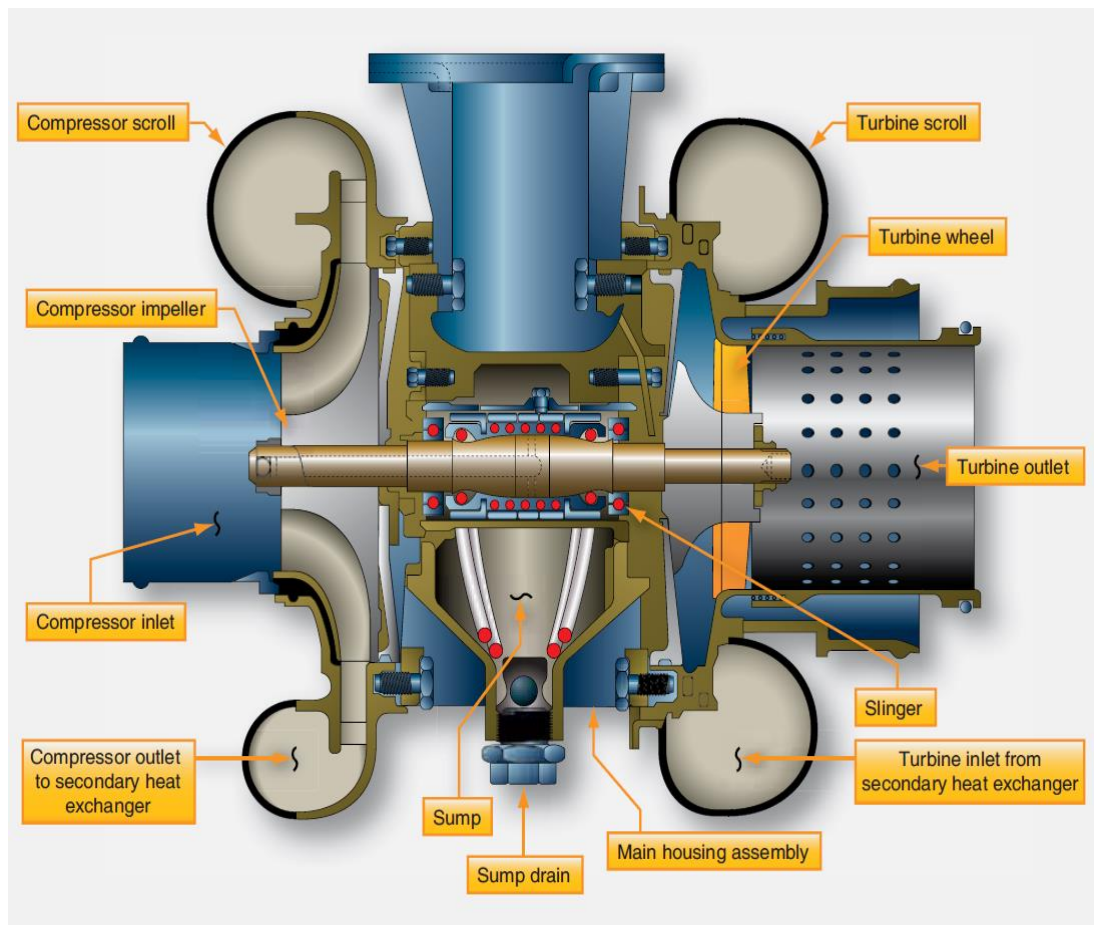

Figure 3.6. Refrigeration turbine unit [8].

### 3.8.3. Separator of the Water

When the temperature of hot air changes to cold, the amount of water in the air cannot be kept. Finds a separation unit that separates water droplets in the air before being sent to the cabin and cockpit. The separation unit works steadily In case of fog air, the system pushes the air from glass fibers in the form of stockings that condense the water droplets and then separate them from the air and then collect the water droplets in a container inside the design of the device After the water is separated from the air, the dry air goes to the airway control unit if the device is clogged (Figure 3.7).

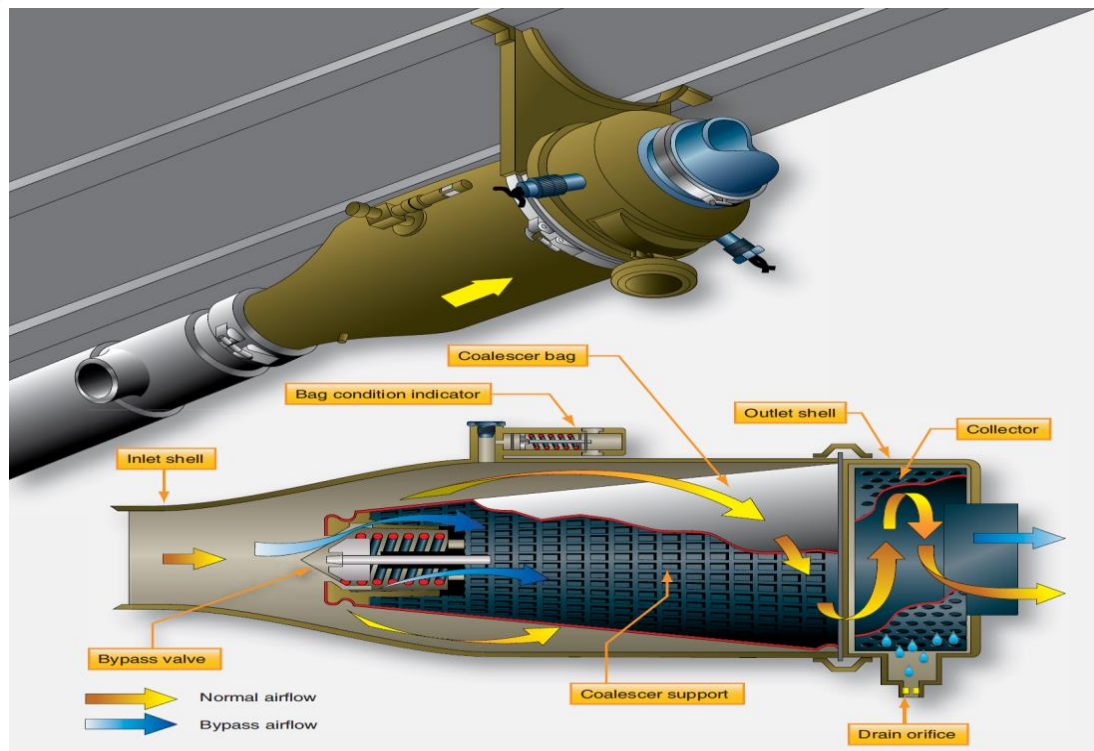

Figure 3.7. Water separator [8].

### 3.8.4. Bypass valve of refrigeration

When the air exceeds the turbine unit it expands and the temperature is close to the freezing point. Then the water in the water separation unit freezes and the water passes closed. In this case, a sensor called temperature control valve, anti-ice valve separates the air, and the position is open if the temperature is 35 degrees Celsius.

The air enters directly into the expansion unit from the upper side of the water separator where it raises the air temperature to prevent it from freezing, the air temperature is thus adjusted by a cooling valve that prevents air passing through the water separation unit from freezing. This bypass valve is visible in (Figure 3.8). All air conditioning systems contain at least one heat exchanger, air circulation unit and expansion valve to remove heat energy from the air recorded from the engine and the presence of variations. The air circulation unit consists of the compressor and air drawn from the main air distributor before going through the heat exchange unit. Water droplets located inside the water separator are sprayed on the ram airflow in the input and then on the heat exchanger to reduce the maximum amount of heat energy of air drawn from the compressor as in the water evaporator. Each part of the cabin has an air-pruning valve to mix the air conditioning with the air sliding from the engine in response to different temperature demands. In the case of increased demand for hot air due to low temperatures, the turbine air valve allows more hot air to pass through the body of the aircraft [Figure 8].

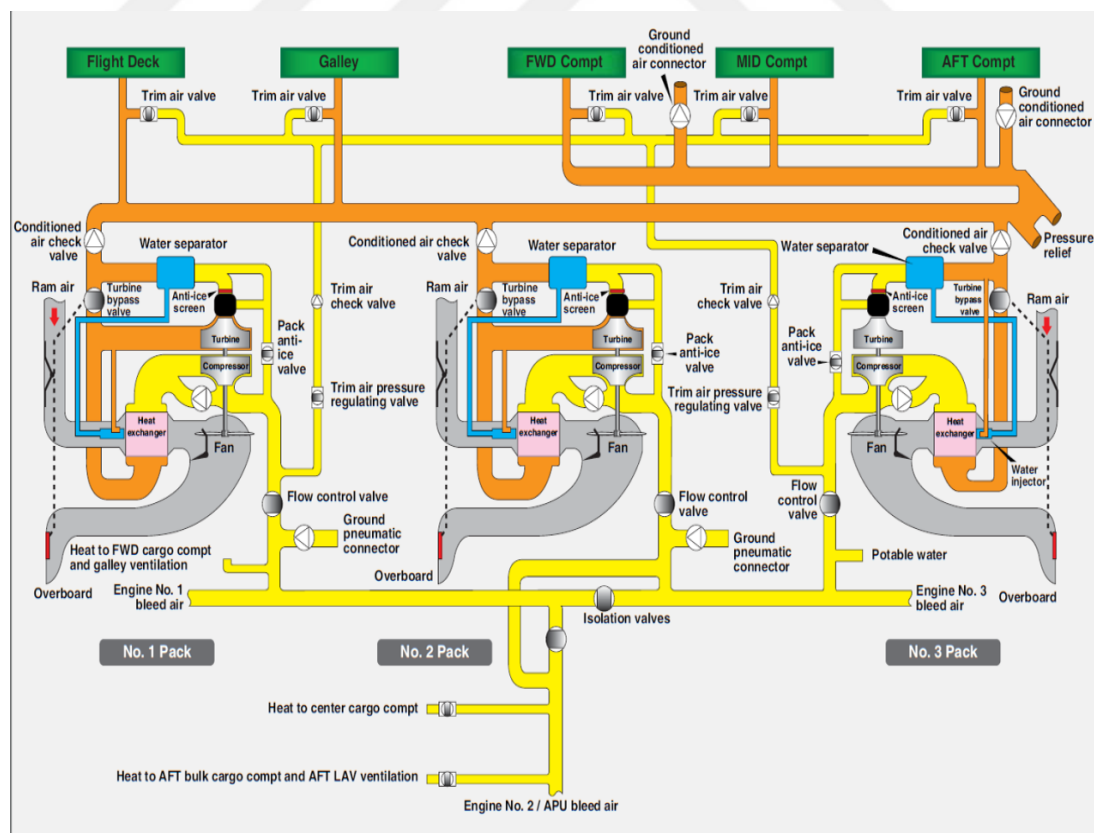

Figure 3.8. Refrigeration bypass valve [9].

### 3.9 VAPOR CYCLE AIR CONDITIONING

The steam circulation air conditioning system is a closed unit. The cooling air is flowed through pipes, control valves, pressure unit and a set of components. The main task is to reduce the temperature inside the body of the aircraft and the cockpit. Cooling is done by pumping cold air into the aircraft, replacing the latent temperature and taking out hot air outside the aircraft.

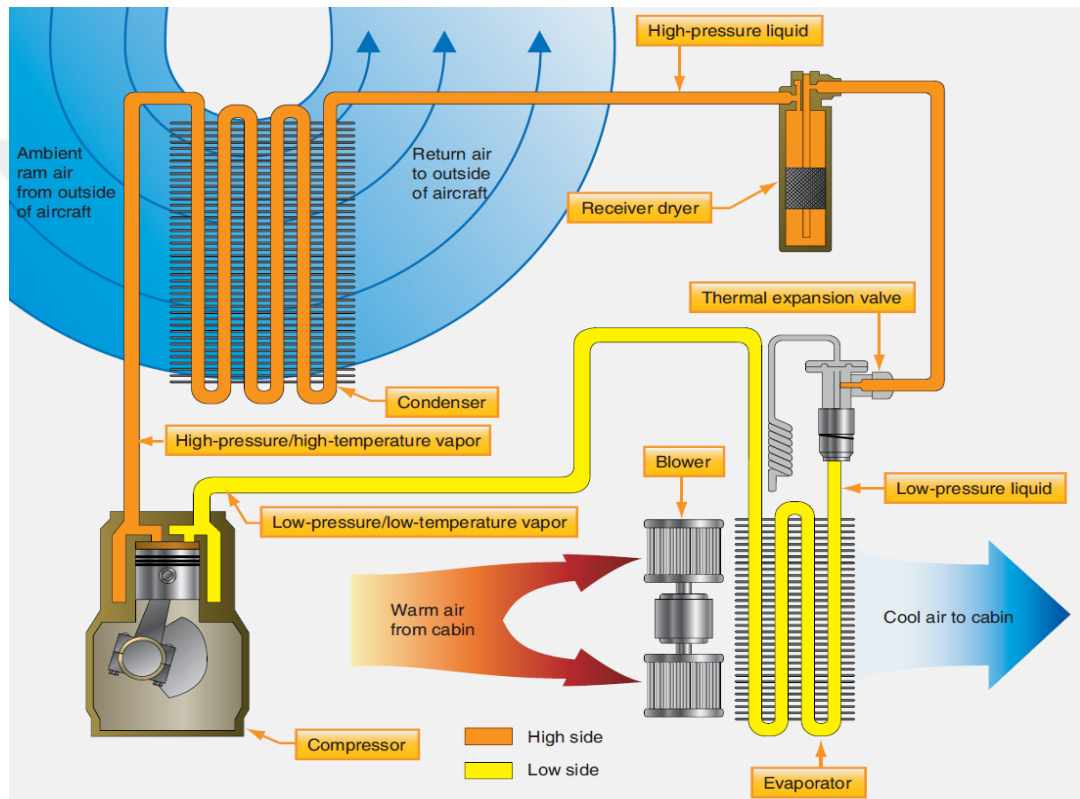

Figure 3.9. Vapor cycle air conditioning [9].

Initially, the air flows after being filtered and stored under pressure calculated in the receiver-drying unit. The cooling fluid is in liquid mode and then exits from the receiving dryer through the pipe unit to the expansion valve. Inside the expansion, valves there are blocks that have small openings through which most of the refrigerant passes and with the presence of pressure all, the refrigerant is forced to pass through these vents. Shows protrusions from small droplets from the bottom side of the valve. The cooling system is a coiled tube inside the radiator unit that installs the fan above the evaporator surface and blows air into the cabin of the

aircraft. The refrigeration unit, which uses latent heat to convert the refrigerant to steam, reduces the temperature in the cabin; the heat is absorbed in the evaporator and then turned into cool air. The steam cycle cooling and air conditioning system reduces the temperature inside the aircraft body. The refrigerant gases inside the cabin evaporator push it into the compressor, increasing the pressure and temperature of the liquid used in the cooling process due to heat. High-pressure gases and heat pass through narrow tubes to the air conditioning unit. The air conditioning unit is a thin, thin pipe connected by thin fins to facilitate the escape of heat to the outside air. The heat inside the refrigerant is higher than the outside air and in this way the heat is transferred from the cooling system to the air outside the system, When the refrigerant temperature is low, the air condenses and turns into a low pressure high temperature liquid and then flows through the tubing to the receiving dryer The steam cycle ends. IN short, the steam cooling cycle consists of two main sections the first section receives heat and is called the low section. The second section expels heat it is called the high section and both indicate the heat and pressure of the coolant (Figure 3.9).

The low side is characterized by low temperature and pressure. The high side is characterized by high temperature and pressure.

### **3.10. VAPOR CYCLE BASIC**

The air conditioning system in the steam cycle theory and how it is working, cooled liquid in a closed unit through pipes, valves, and other components this system is used to reduce the temperature in the cabin of the aircraft is the movement of coolant fluid is formed through the system. The cooled liquid evaporates and absorbs the underlying heat and then replaces hot air with cool air inside the cabin. The coolant fluid is stored and filtered under appropriate pressure in a tank called the receiver-drying unit. When the radiator is on the fluid body it moves through the pipes from the receiver unit to the expansion valve, Expansion valve has a small manifold in the form of restrictions to prevent refrigerant. Due to the high pressure of the refrigerant, some of the refrigerant passes through the opening unit.

The coolant fluid is sprayed and converted into a spray of small droplets through a small tube located in the lower direction of the valve. The evaporator unit is then connected to the tube and the air inside the aircraft is then directed to the surface of the evaporator unit using a fan. The temperature inside the cabin decreases by absorbing the heat from the hot air and this raises the temperature of the cooled chiller until it becomes vapor. In this way, the cabin of the aircraft spawns heat and is replaced by cold air using a fan and evaporator unit, this is an explanation of how the cabin of the aircraft using the theory of air system air conditioner for the steam cycle. The liquid pressure unit receives the coolant in the form of steam coming out of the evaporator unit into the compressor valve where the coolant pressure and heat are increased. The condenser receives the radiator unit as a vapor at high temperature through the pipes. The condensing unit consists of long tubes and thin fins connected to pipes to distribute the escape of the most heat, the cold air ram passes through the pipes and fins and the heat moves from the condenser to the ram air to reduce the coolant temperature. Briefly explain the theory of the steam cycle of the air conditioner. The refrigerant passes to the pressure unit after exiting the evaporator. Coolant pressure rises due to high temperature. The liquid coolant turns into steam and moves through the pipes to a condenser that resembles a cooling condenser. The condenser consists of long and thin tubes connected to thin fins to accelerate the escape of the warmer from the radiator. Fresh cold air passes through the condenser unit and the coolant temperature is higher than that of the ram air and condenses the radiator turns from a vapor to a liquid under pressure. The receiver dryer receives the coolant in the form of compressed liquid and thus the steam conditioning cycle. The steam conditioning cycle is divided into two parts. The first section receives heat and is called the low side the second section and high temperature is called the high side and this abbreviated liquid form with different pressure and temperature. The expansion valve and compressor separate the low side and the high side. . [Figure 20] The pressure and temperature are high on the high side and the pressure and temperature are low on the low side.



## 2.11. MAIN PARTS OF THE AIR CONDITIONING SYSTEM FOR THE STEAM CYCLE

### 2.11.1. Liquid Coolant

For a period, a chlorofluorocarbon and methane gas was used in the air conditioning system for the steam cycle of aircraft, To this day, these systems are still used in aircraft Some environmental scientists found that methane gas has a negative impact on the weight layer and the environment in general. For this reason it has been replaced by tetrafluoroethane because it is considered safe on the ozone layer and on the environment. R12 and R134a should not be mixed and one should not be used in the second place each coolant has its own system. In the event of a mistake in the use of cooling agents, this leads to damage to the components of the material from the plastic material and then a malfunction or leakage and then all the system stops working. The chiller should be used each according to the system designed for him during the periodic maintenance of the air conditioning systems with periodic steam The R12 and R134a systems are very similar, with each system having the same components The use of each refrigerant must therefore be saved for its own system.



Figure 3.10. Refrigerant [8].

R134a is a halogen compound ( $\text{CF}_3\text{CFH}_2$ ). As mentioned, it has a boiling point of approximately  $-15^\circ\text{F}$ . It is not poisonous to inhale in small quantities, but it does displace oxygen. Suffocation is possible if breathed in mass quantity. All refrigerants are called FREON. Safety measures should be observed when working directly with all refrigerants because they have a very low boiling point, If fired into the air, they



boil violently when exposed to appropriate temperature and pressure. It also has a great absorption speed of thermal energy from the surrounding objects. There are major burns in the skin in the case of direct contact as well as blindness occurs if it falls on the eye and this requires the use of safety tools when maintenance or periodic detection such as gloves Safety glasses.

### **2.11.2. How the Receiver and Drying Work**

The receiving and drying device has a specific function in the system is storage and drying of liquid coolant. It is located in the system under the condenser and above the expansion valve, In the case of high system temperature, an excessive amount of coolant flows into the system compared to low system temperatures. The dryer unit receives the cooled liquid when the temperature drops and is used more often if the temperature rises again. The coolant enters under pressure into the system to lower the system temperature by means of filters located in the liquid flow lines. Filters eliminate alien and harmful substances of the system. In the case of water, the dryer discards droplets in the coolant ducts. Water, if found in the system, causes many problems and major defects such as the conversion of coolant liquid to acid and then lead to corrosion in parts made of plastic and rubber and leakage inside the system. Clogged liquid cooling lines around the cooling system due to the transformation of the cooled liquid into ice are also serious problems due to the failure of the cooling system completely and become ineffective. When ice beads form, they close the expansion valve because it is considered the coldest part of the air conditioning cycle and if there is a blockage in the manifolds inside the expansion valve, it is hard to get rid of the ice. In the case of periodic inspection of the cooling system, technicians make the system operate at the lowest level of cooling to allow the coolant fluid to flow to the expansion valve. The carrier tube has a section of visible glass that allows specialists to check the level of coolant inside the system. In case of seeing the flow of the refrigerant, this gives an indication that the amount of refrigerant is insufficient and if there are patches, it shows a decrease in the amount of liquid. The presence of patches within the glass portion is the largest evidence of low-level liquid cooling (Figure 3.11).

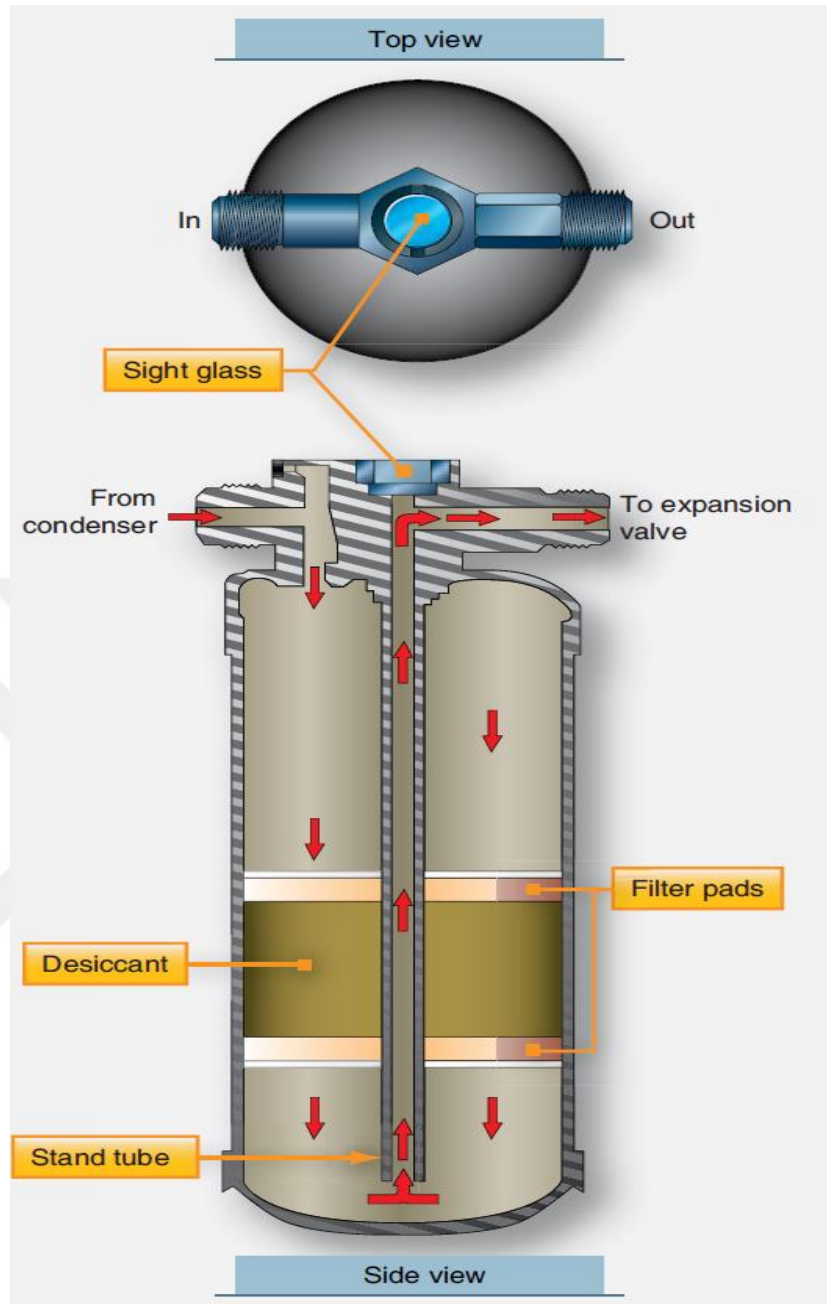

Figure 3.11. Receiver dryer [10].

### 2.11.3. Describe and How the Expansion Valve Works

The expansion valve receives the flow of the coolant from the receiving dryer where it has openings that can be adjusted to allow specific amounts of refrigerant to pass through the system for perfect cooling. The next part after the expansion valve is the evaporator unit and when detecting the temperature in this part can determine the level of adjustment in the expansion valve. The expansion valve has the main

function of determining the amount of fluid needed to fully vapor into the evaporator unit. The amount of refrigerant required from the expansion valve depends on the temperature required within the body of the aircraft. When the temperature inside the aircraft rises, the expansion valve allows a larger amount of refrigerant to enter into steam in the evaporator unit. When the coolant fluid turns from liquid to steam due to high temperature, the largest amount of heat energy is absorbed. When the temperature increases, the expansion valve allows the passage of more refrigerant to absorb the high temperature, but if the fluid flows more than necessary, it stays as a liquid when it comes out of the evaporator unit. The flow of refrigerant fluid from the evaporator unit to the compressor is the next stage should take into account the pressure or will occur problems and cracked in the compressor unit. The compressor is designed to compress the vapor coming out of the evaporator, but in the case of liquid, the liquids are not compressible if the fluid comes under pressure, the compressor crashes and causes problems for the air conditioning system. The temperature of a refrigerant that has not completely evaporated differs from that of the evaporator. So a sensor is installed at the evaporator outlet to sense the temperature difference between the liquid and the steam. This sensor has two stages, the first part is located at the end of the evaporator to feel the heat of the outside steam. The expansion valve consists of a diaphragm and a spring in a tube on the cylinder body. When the temperature of the cooling fluid rises, the pressure rises and the diaphragm overcomes the force of the spring and then allows a larger amount of coolant to pass through the evaporator unit. When a larger amount of coolant is added as a result of the latent temperature rise, the chiller turns the steam temperature of the steam does not increase. If the fluid increases more than required, the temperature decreases and this leads to the force of the spring over the diaphragm, closing the flow of more cool liquid. Large steam conditioning systems face some problems, including the flow of coolant in large quantities under high pressure within the system.

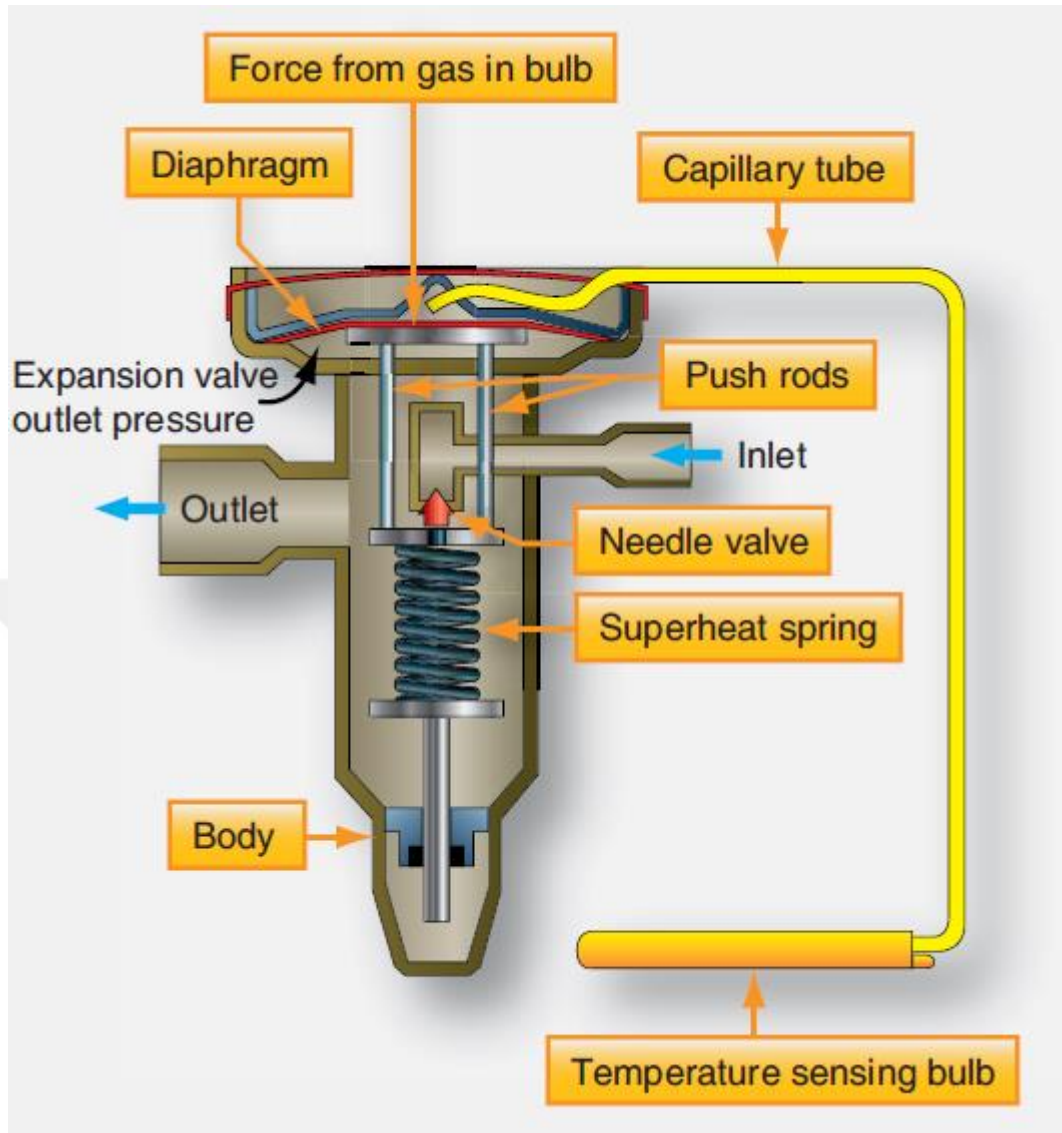

Figure 3.12. Expansion valve [10].

To solve this problem, a small pressure spout is needed and installed at the exit point of the evaporator to return the excess liquid to the coolant outside of the expansion valve. This type of system is recognized when there is an additional small passage that connects the evaporator to the expansion valve and collects excess liquid coolant drops.

#### 2.11.4. Evaporator Unit

There are many types of vaporizers in shape and appearance, but they are all similar in design. The evaporator unit consists of a pipe unit made of aluminum, copper for

lightweight and metal strength, and is connected to a group of thin fins to facilitate the escape of air. Hot air flows through the cabin of the aircraft through the evaporator unit and there is a fan to maintain adequate airflow. The coolant fluid passes under high temperature and high pressure from the expansion valve into the evaporator. The thermal energy within the cabin is absorbed into the evaporator unit by absorbing the coolant fluid that turns from liquid to steam because of heat absorption And low pressure. Heat absorption by the evaporator allows high temperatures inside the cabin to be reduced in the steam conditioning cycle. The next locality is the compressor that receives the coolant in the form of a low-pressure vapor and then the pressure and heat are discharged at the evaporator unit and this allows the expansion valve to operate normally. It is important to use a fan to draw air from the body of the aircraft and pump the cold and fresh ram air around the evaporation unit to enter the cabin and driving unit. Sometimes the air inside the cabin is used to pass through the evaporator unit and enter again into the cabin when temperatures are moderate and when the evaporator is installed at the cabin wall.

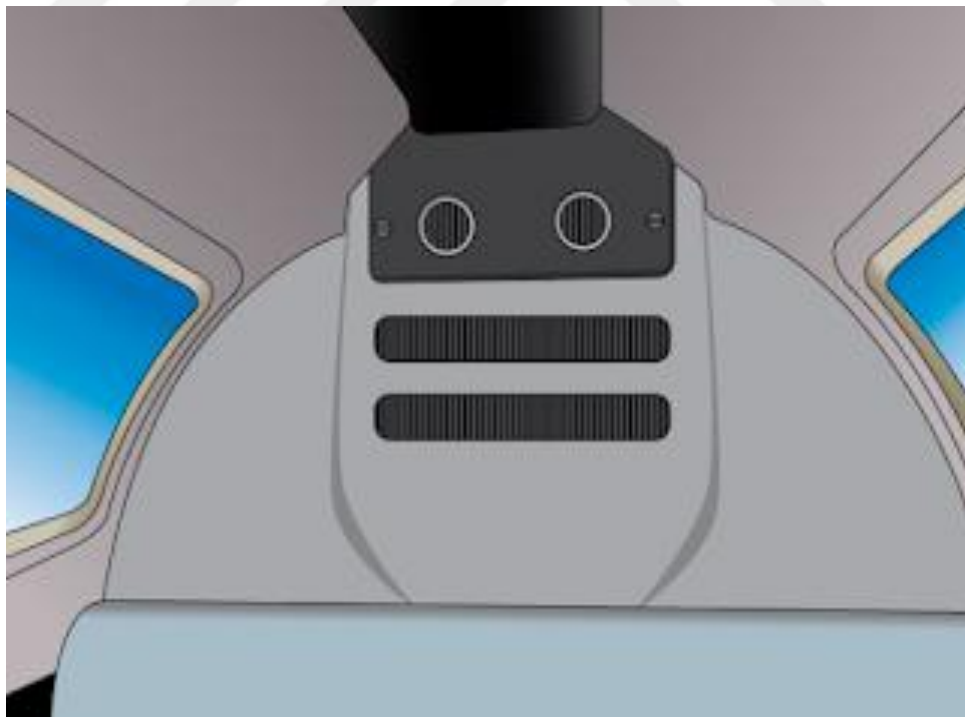

Figure 3.13. Evaporator [10].

Cold air from the air conditioning system is pumped directly into the cabin if temperatures are high and distribution is carried out regularly. Water droplets on the resulting evaporator are formed by the heat transfer that occurs in the cooled liquid. These droplets must be discarded around the evaporator and sent out of the aircraft so that they do not freeze. If the aircraft is compressed, some types of valves are used to remove water and maintain pressure inside the aircraft. The thin fins in the evaporator unit are of high importance and important impact on the entire air conditioning unit and must be maintained from damage. Smooth air circulation around these fins does not allow snow to condense and close air ducts that adversely affect the evaporator unit.

#### **2.11.5. Describe How the Compressor Works**

In all air conditioning systems, the steam unit is the main compressor in the system. It works to compress the cooled liquid, which is in the form of steam until the cooled liquid moves, and the cycle is completed for each cooling system. The coolant fluid flows in the form of steam under low temperature and pressure from the evaporator unit to the compressor unit. At the pressure of the cooled steam in the pressure unit, the pressure and temperature of the steam raises Compared to ambient air. The cooled steam flows at high pressure and temperature to the condenser unit and is the next unit, which expels heat to the outside air and reduces the pressure steam. The compressor is installed in different places in the aircraft, but its central position in the system in the middle and is designed to receive steam and pressure until it reaches the next part condenser.

The compressor and its connection to the source of movement depends on the size of the aircraft in small planes is connected directly to the engine in the main deliberate motion In large aircraft, the compressor is connected to an electric motor separate from the aircraft engine. There are many ways to operate the compressor, but the modular method is similar in automotive systems, where the compressor is connected to the main shaft of the car engine through a belt. The compressor is connected to an electromagnetic switch that automatically operates when the temperature inside the cabin is increased, allowing the compressor to communicate with the main drive

shaft of the engine In the case of low temperature, it disconnects the compressor and stops the movement of the system. In the case of the use of the compressor, which is powered by an electric motor can be installed anywhere in the aircraft and is connected to electrical wires connected to the cabin of the aircraft. If the compressor is hydraulic, it is directly connected to the main hydraulic system in the aircraft.

As for how the compressor works, it works by a piston that moves vertically up and down and uses a light viscosity oil to soften the movement of the piston inside the compressor. The softening oil moves inside the piston by the circular piston movement and the oil is sprayed on all sides of the compressor (Figure 3.14).

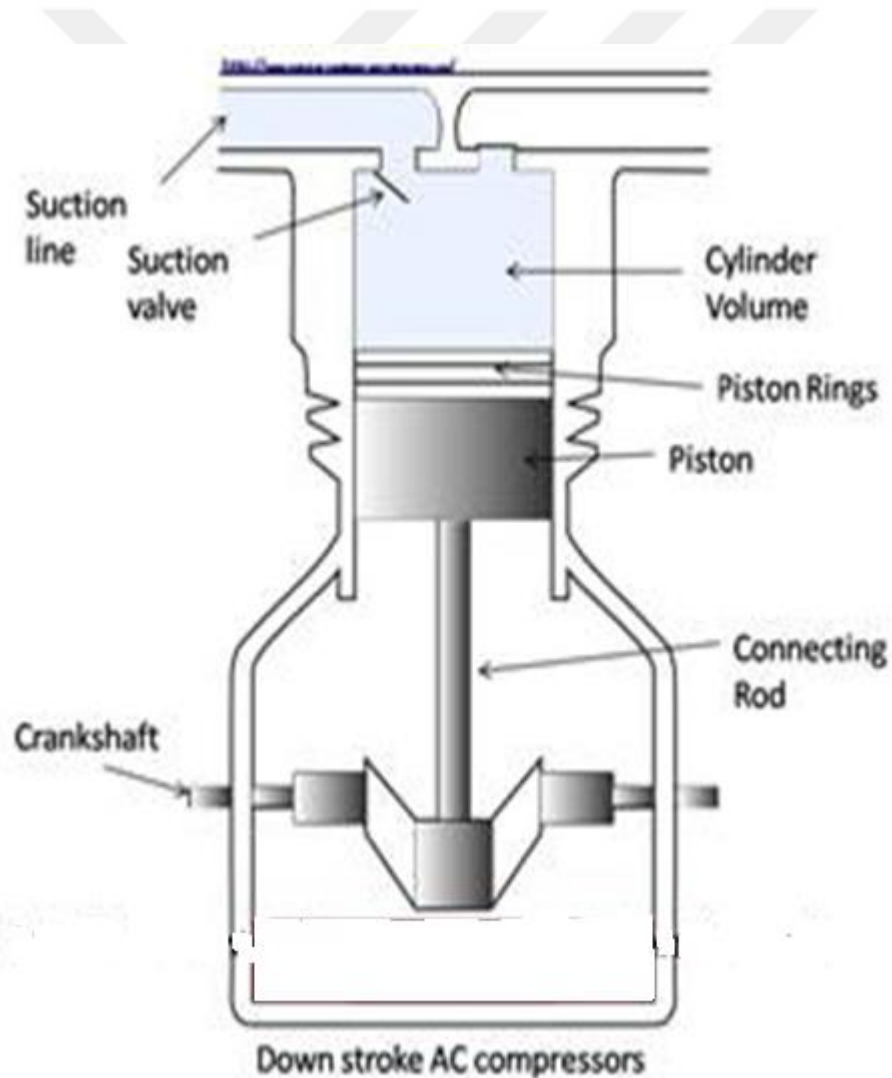

Figure 3.14. Compressor [10].

The oil should be inspected in terms of quantity and viscosity periodically when performing regular maintenance and the compressor is separated from the rest of the system so that the oil does not leak.

#### **2.11.6. Description and Operation of the Condenser Unit**

The liquid cooled on the vapor form flows from the compressor to the next unit, a condenser unit under high pressure and high temperature to the last part of the air conditioning system in the steam cycle. The condenser is a radiator or heat exchanger in which the high temperature of the coolant is ejected or eliminated due to its original form. Usually the condenser is close to the outside parts of the aircraft or outside the aircraft so that a large amount of cold ram air can pass through the condenser unit. A fan is used to draw a large amount of air and pass around the compressor to lower the temperature (Figure 3.15).

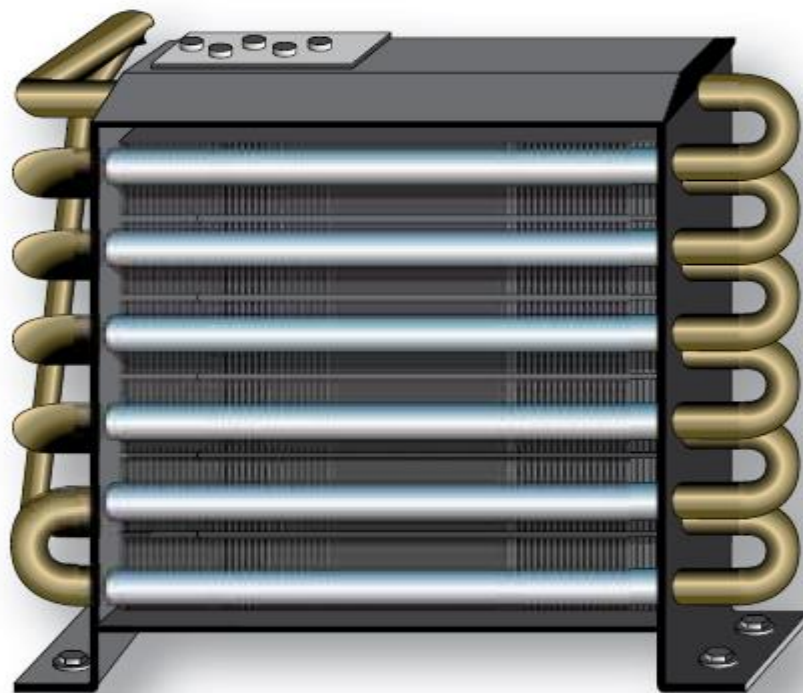

Figure 3.15. Condenser [10].



The ram air reduces the temperature of the refrigerant by absorbing the heat in it through the condenser. The condenser works mainly to return the coolant to a liquid and lower the temperature and then send it to the dried receiver unit to condense and collect all the coolant liquid.

### 2.11.7. Method of Service Valves

All types of air conditioning systems operate steam cycle closed but must be accessed within the system for the purpose of conducting some periodic services and tests. Some types of valves are used for inspection and maintenance a valve is installed in the upper side and the other in the lower side of the air conditioning system. One of Schrader's most common valves for refrigerant fluid services in the cooling system is the steam unit. This valve works similar to the valves used in car tires. The valve core is opened and closed by pressing the needle in the hose used to serve the refrigerant. After not using, the valve for the purpose of services must be closed tightly using a metal cover or plastic. In R134a, the service valve is similar to the Schrader valve in operation and position. To prevent and ensure that refrigerant use is not confused there are differences in Schrader and R134a valve fittings and cannot be confused.

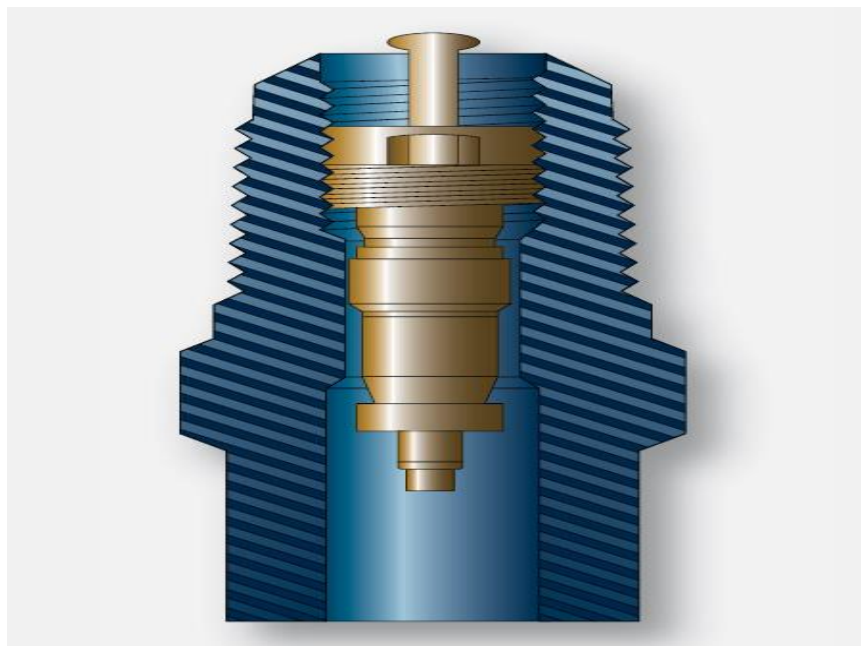

Figure 3.16. Service valves [10].

In some modern airplanes a different type of service valve is used, called a dielectric valve. This type works similar to Schrader and the compressor unit can be separated from service. In this type of valve can be performed services for refrigerant as in Schrader valve and at the same time can check the oil level in the compressor unit without the need to open all the system This saves effort and time and no refrigerant loss. The installation of this valve on the compressor unit is tight in the inlet and outlet area of the compressor unit. It has three modes of full opening and closing and the center position. When fully open, the refrigerant is allowed to pass naturally into the system. When it is in a fully sealed position, it completely isolates the compressor unit from the rest of the system. Technicians can perform inspections and services on the compressor. When in the middle position is allowed to carry out maintenance operations for the whole system and after the completion of periodic services for maintenance and detection must return the valve to the first position fully open. Use a metal or plastic cap to ensure that the valve is sealed and not tampered with at the time of regular maintenance (Figure 3.17).

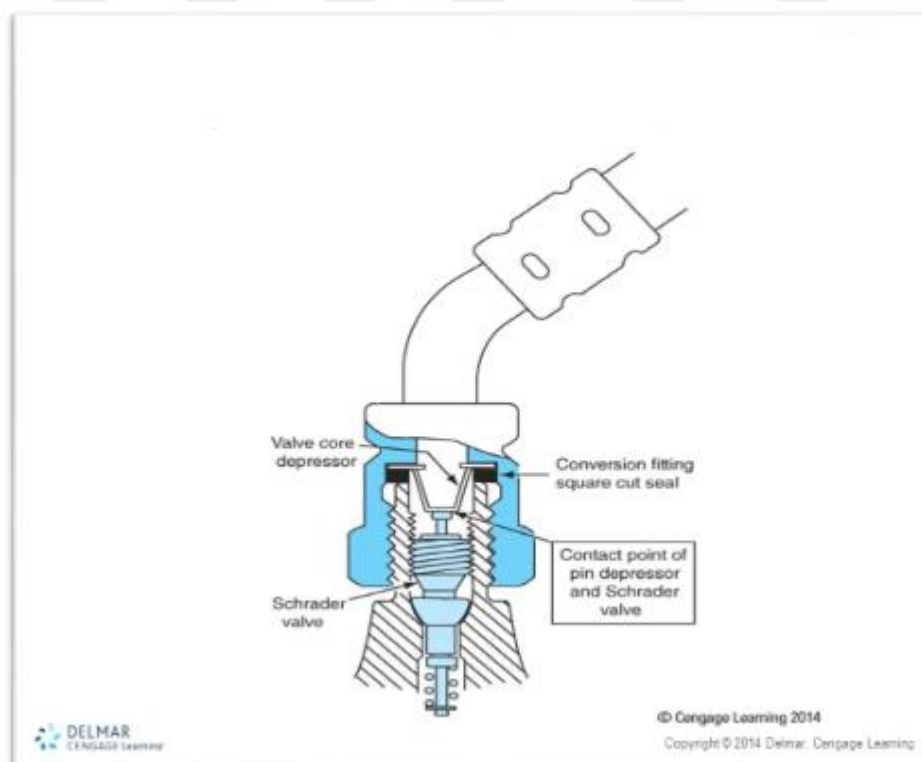

Figure 3.17. Service valves [10].

### **3.12. AIR CRAFT HEATING SYSTEMS**

Aircraft heating system different range in size and complexity and cost from simple heat exchangers for small single engine aircraft through combustion heaters used with larger aircraft use compressor bleed air systems for turbine - engine powered aircraft. The system being used may be independent of other systems or integrated into complete aircraft environmental control package [5].

### **3.13. MITIGATE ICE ACCRETION ON WIND TURBINE BLADES**

Ice forming on wind turbine blades of the engine can cause loading imbalance and reduce power production of the turbine system. Heating systems that prevent or remove ice on wind fan blades are one of the more promising solutions to mitigate ice accretion. Methods to apply heat include (direct application through electro-thermal resistance heaters mounted on the external surface of the leading edge blade) or by forcing hot air through a ducts along the leading edge of the blade. Heating systems for aircraft blades have become standardized and in some cases compulsory on aircraft to preserve human life; however, the technology is not directly transferable to the blades on wind turbines. The relative power of the anti-icing or de-icing system is critical to providing a cost benefit of having the system. An appropriate range of operating conditions and blade constructions are considered in order to characterize the effectiveness of both systems. A numerical model is developed to solve the one dimensional, differential heat transfer equations. The heater power required to prevent ice accumulation (anti-icing) on wind turbine blades is determined for electro-thermal heating. Anti-icing with hot air is shown to be unrealistic for a practical range of operating conditions. The low conductivity of the blade core creates a bottleneck for the de-icing system. It is shown that alternative core materials (Nomex/aluminum honeycomb) can reduce this effect. Electro-thermal and hot air de-icing each have their advantages and cannot be equally compared. In this thesis, the suitability of each system has been analyzed for a range of operating conditions.

### **3.14. FUEL THERMAL SYSTEM**

The architecture consists of a tank or integrated tank system, a heat exchanger to transfer airframe and/or engine thermal loads to the fuel, a splitter valve controlled by fuel temperature that regulates the amount of recirculate fuel, and a ram air or other fuel cooling heat exchanger in the tank return circuit. In addition to transfers in the exchangers, heat flows to or from the stored fuel mass itself via tank wall conduction and in-tank sources are also incorporated via, respectively. This architecture is intended to model a simple representative system; however, it can represent more complicated system designs by lumping elements into this canonical architecture through parallel or series combination of heat transfer rates, temperatures, and mass flows. Although pumps are not shown in the system architecture, pump operation is implied for maintaining the required fuel flow rates, and heat loads from pumps upstream of the splitter should be incorporated.

### **3.15. TANK TEMPERATURE INTEGRATION**

In the following approach, the recirculation system is modeled as operating continuously. This condition corresponds to the second mode of operation described above. It can be expected that if this condition for recirculation is met at the beginning of a mission segment, it will remain in effect throughout the segment if the loads remain constant or increase. An exceptional case would be if the tank wall heat transfer is negative and especially large; however, in modern subsonic and low-supersonic aircraft with composite skins, wall heat transfer is typically small in comparison to other heat transfer mechanisms. The need for continued recirculation during a mission segment tends to be self-reinforcing because TT increases with recirculation, and  $\dot{m}_E$  decreases as the aircraft weight is reduced during cruise by mission fuel burn. The a priori presumption of continuous recirculation instead of switching based on instantaneous values of TT results in a linear differential equation which can be integrated straightforwardly and in closed form to reveal the dependencies of tank heating on system design and operation [1].

### 3.16. WHAT IS THE AIRCRAFT HEATING SYSTEM TYPES

#### 3.16.1 Exhaust Heating Systems

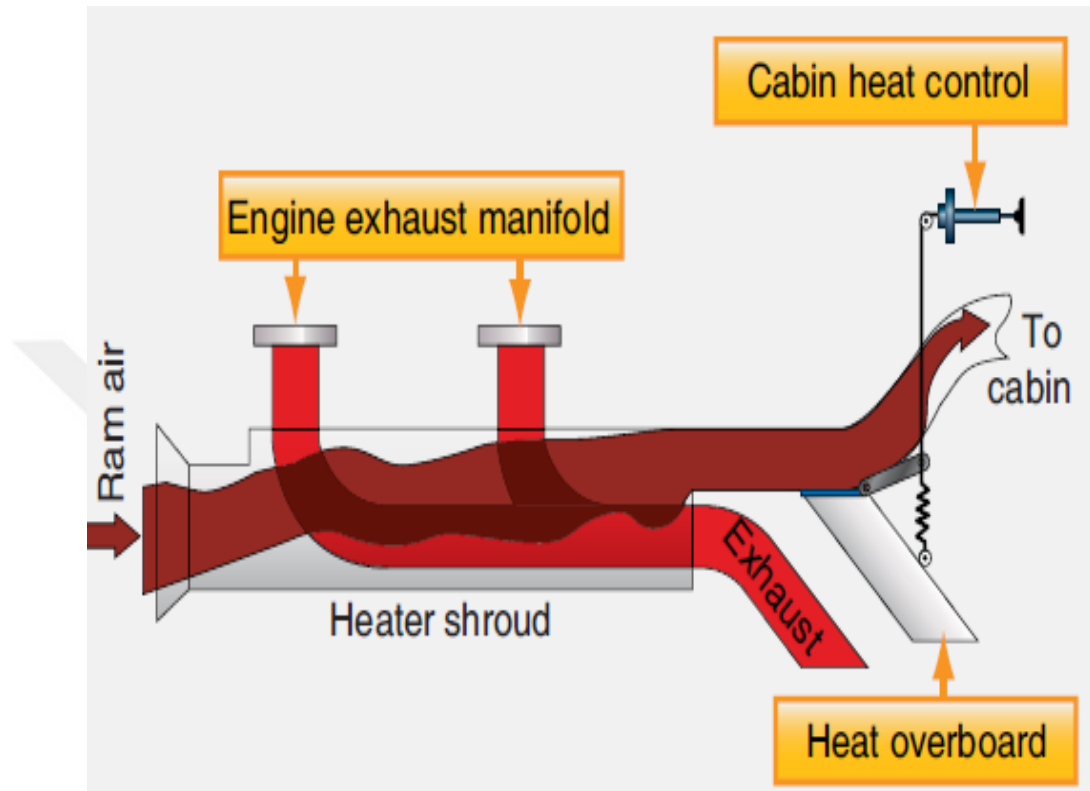

Figure 3.18. The simplest type of heating system [1].

The simplest type of small heating system, often employed on light single engine aircraft. Consist of a heater muff located around the engine exhaust stacks, an air scoop to draw ram air from outside into the heater muff ducting to carry the heated air into the cabin and a valve used to control the size of the flow of the heated air. And it is only used in small air craft. This type of heating system is not safe for all the flight condition because the small leakage in gases lead to contamination in the cabin air (Figure 3.19) [6].

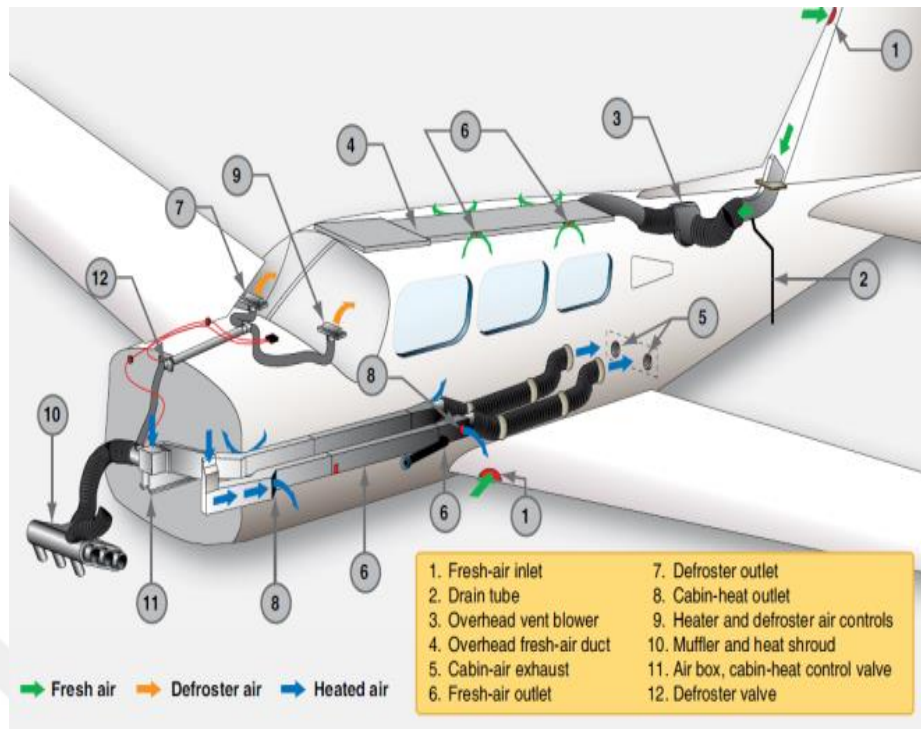

Figure 3.19. The simplest type of heating system [1].

### 3.16.2. Electric Heating Systems

Electrically operated heaters are used on some small to medium aircraft size to provide heat energy in the cabin area when the aircraft is on the ground with the engine not running; Aircraft that typically incorporate this type of system include the smaller turboprop. Powered aircraft. The auxiliary electric heat system use air from the inside of the aircraft body by the use of a recirculation theory for -the air then passes the air over electrically heated coils unit and flows back into the cabin through the aircraft heat supply ducting as (Figure 3.20).

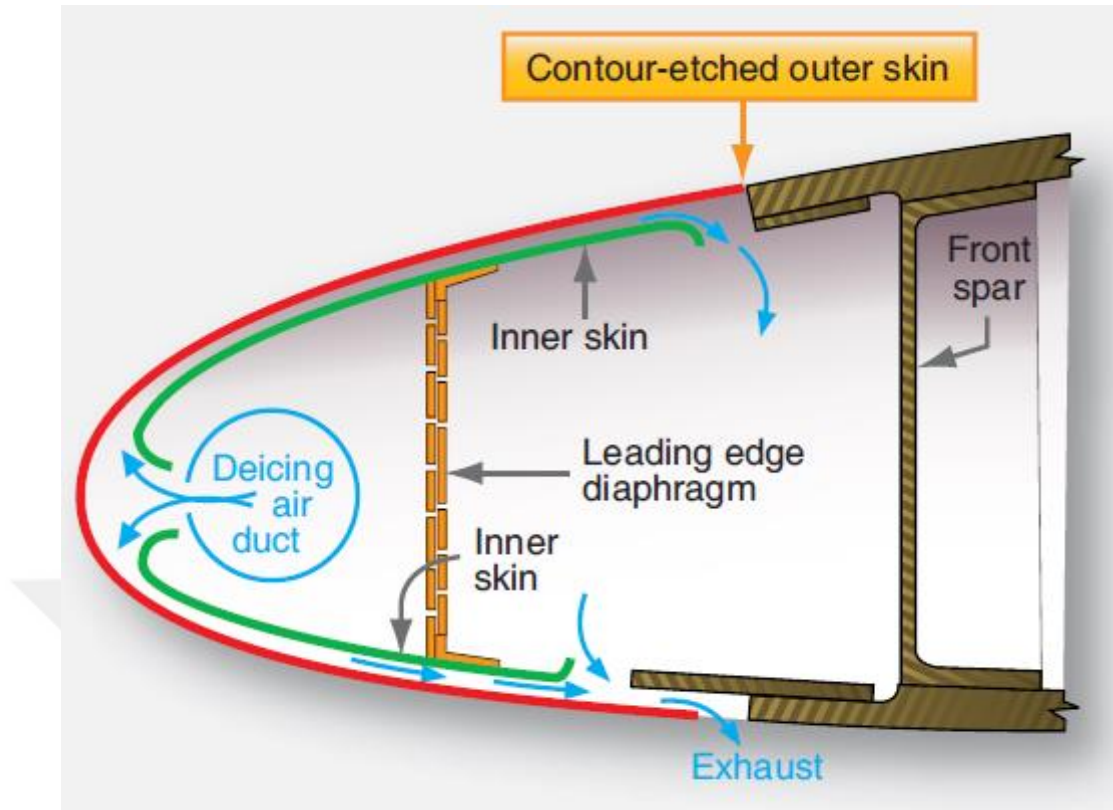

Figure 3.20. Electrical heating system [22].

The electrical heating system that used in small aircraft is fixed to use for anti-icing system, which is important to the flight controls free movement in all flight conditions.

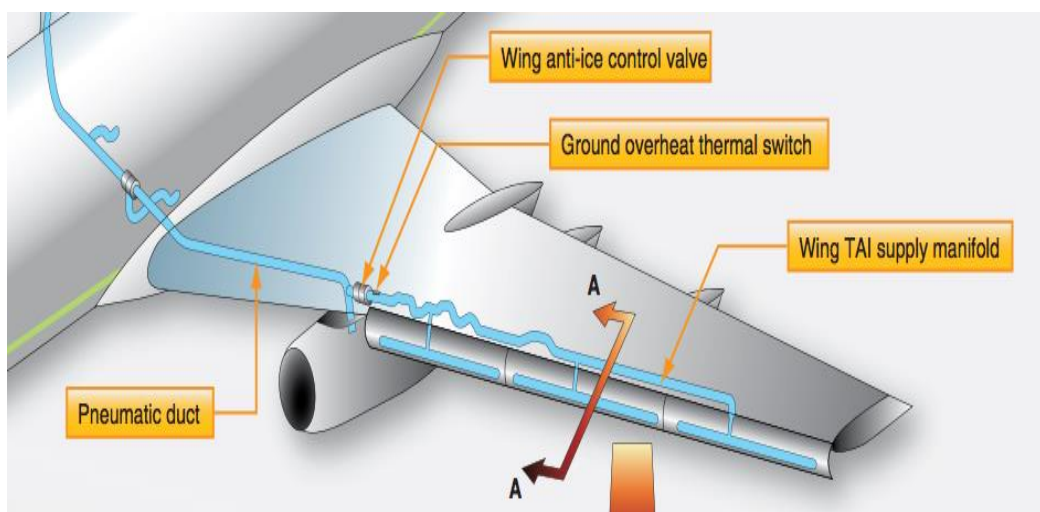

Figure 3.21. Electrical heating system wings [23].

### **3.16.3. Heating with Bleed Air**

Unpressurized turbine aircraft types are used compressed air from the turbine engine to provide the hot air for cabin heating and anti-icing system. When a turbine engine compresses ram air prior to pass it to the engine combustion chamber. the air temperature will increased by several hundred degrees Fahrenheit by the compressing action, some of this compressed heated air, called bleed air, can be diverted directly to a cabin heating system [7].

### **3.16.4. Combustion Heater Systems**

In larger and more expensive aircraft, combustion heaters also referred to as surface combustion heaters are often used to supply the heat needed for the cabin and anti-icing system. This type of heater use the same aircraft fuel that is needed to burn it in a combustion chamber or tube to develop the required heat, ram air pass around the heated tube and carried through ducting to the cabin. A combustion heater system is covered in this report of our project [7].

## **3.17. COMBUSTION HEATERS**

This type of combustion heater is mainly used in small and medium-sized airplanes and is still used at this time. This type of combustion heater works to produce the heat energy needed to heat the cabin of the aircraft and works completely independently of the jet engines. The fuel used in this type of combustion heaters is gasoline and is fed from the same main fuel tank of the aircraft. The companies producing this type of combustion heaters are not many and, are the same companies producing aircraft spare parts. All types of this combustion heater are similar in theory of work, shape, and components with some differences in modern systems. Modern systems feature a control switch installed in the cab to control the amount of heat. The way this combustion heater works is close to the exhaust system used in cars. It has a combustion chamber that operates completely independently to produce thermal energy from the main engines of the aircraft. When the combustion process occurs inside the combustion chamber, the metal temperature rises and a piece of



palm are fixed around the chamber and then the ram air passes between the combustion chamber and the shroud the air temperature rises and is sent to the aircraft cabin. The air and fuel enters fixed and modified proportions into the airtight combustion chamber the combustion gases are then discharged through the exhaust passage out of the aircraft. After the start of the process of combustion and high temperatures are allowed ram air to enter and pass around the combustion chamber and metal shroud to ensure the transfer of heat to the air.

The method of work of this burning heater at the beginning is to mix the fuel with air and then enter the combustion chamber after ignition. This mixture is disposed of the exhaust out of the plane through the exhaust pipe. The ram air passes through this chamber and the metal shroud so that the air temperature rises and is completely isolated from the exhaust so that no pollution in the heating air occurs.

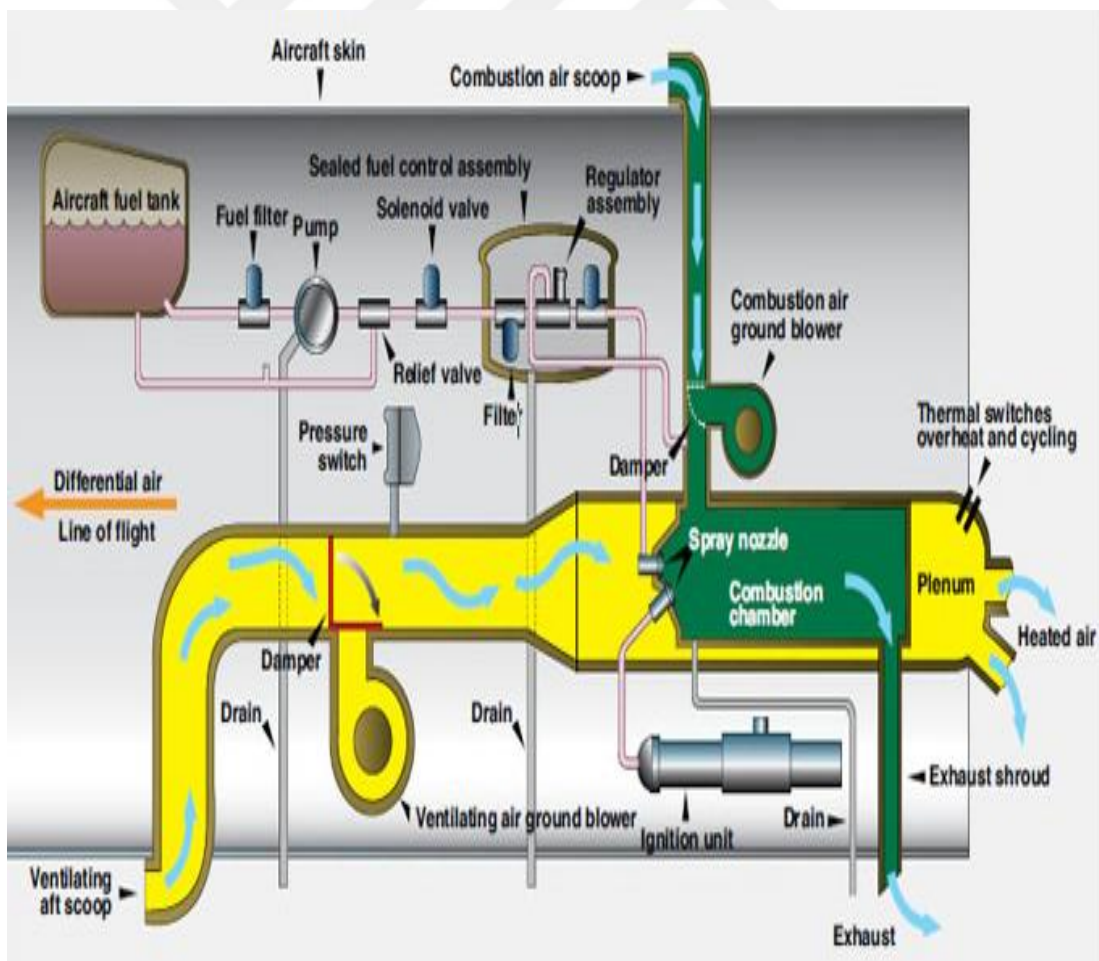

Figure 3.22. Combustion heaters [11].

The size of the aircraft is the main factor determining the size and type of combustion heater. Combustion heater can be used separately or more than one in one plane, depending on the need for the amount of heating in the plane. A plane may need more than one small combustion heater or one large combustion heater that meets the purpose.

### **3.18. THE MAIN PARTS OF EACH COMBUSTION HEATER**

- Sufficient amount of gasoline fuel.
- A spark to complete the fuel combustion process.
- The amount of ram air is sufficient to maintain the flame.
- Disconnected corridor for exhaust disposal.
- Integrated unit of tubes for transporting ready hot air and distributing it regularly in the cabin of the aircraft.

Heaters are same in theory of operation and construction features. The major differences are in the methods of introducing fuel and in the location of units and accessories in aircraft. The various components that comprise a complete aircraft heating system are shown schematically in (figure 3.23). Air inlet, fuel tank, fuel lines.

Igniter plug with pressure gap fail- safe combustion air, pressure switch, and control fuel solenoid with integrated fuel filter combustion, chamber blower, and long-life permanent magnet blower motors.

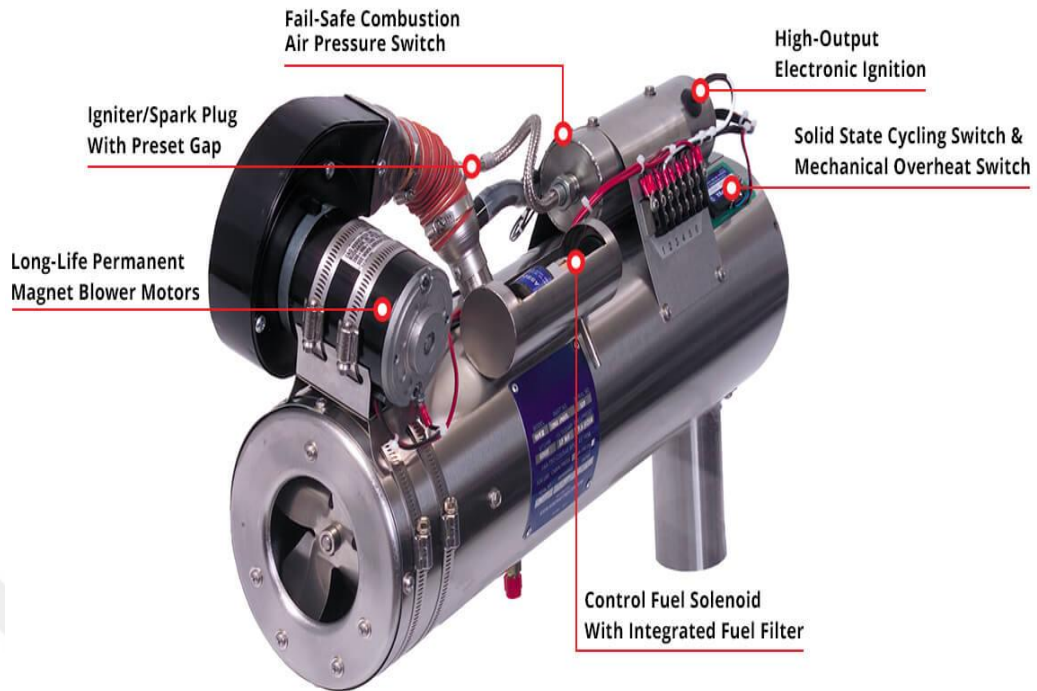

Figure 3.23. Combustion heaters [11].

### 3.19. HOW TO PROVIDE VENTILATION AIR

The cold air is called the ram with ventilation air and is used to transfer heat energy to the cabin of the plane after raising its temperature. An amount of ram air is withdrawn and passed to the hot surface of the combustion heater when the plane is on the ground. A fan is used to provide a sufficient amount of fresh air. Once airborne, the fan ceases to operate, as the ram airflow is sufficient. Ventilating air passes between the combustion chamber and the outer shroud of the combustion heater where it is warmed and sent to the cabin.

### 3.20. HEATER FUEL SYSTEM

As mentioned, gasoline fuel that used for the combustion heater is drawn from an aircraft main fuel tank. A constant pressure fuel flow pump with relief valve press the fuel through a filter. A main solenoid valve downstream delivers the fuel to the combustion heater unit. The solenoid is controlled by the cabin heater switch in the cockpit and three safety switches located on the combustion heater. The first safety

switch is a duct limit switch that keeps the valve closed should the unit not have enough ventilating airflow to keep it within the correct operating temperature range. The second is a pressure switch that must sense pressure from the combustion air fan to allow the solenoid to open. Fuel is delivered to the combustion chamber only if there is air there with which it can be mixed. Finally, an overheat switch also controls the main fuel supply solenoid. When an over temperature condition occurs, it closes the solenoid to stop the supply of fuel (Figure 3.24).

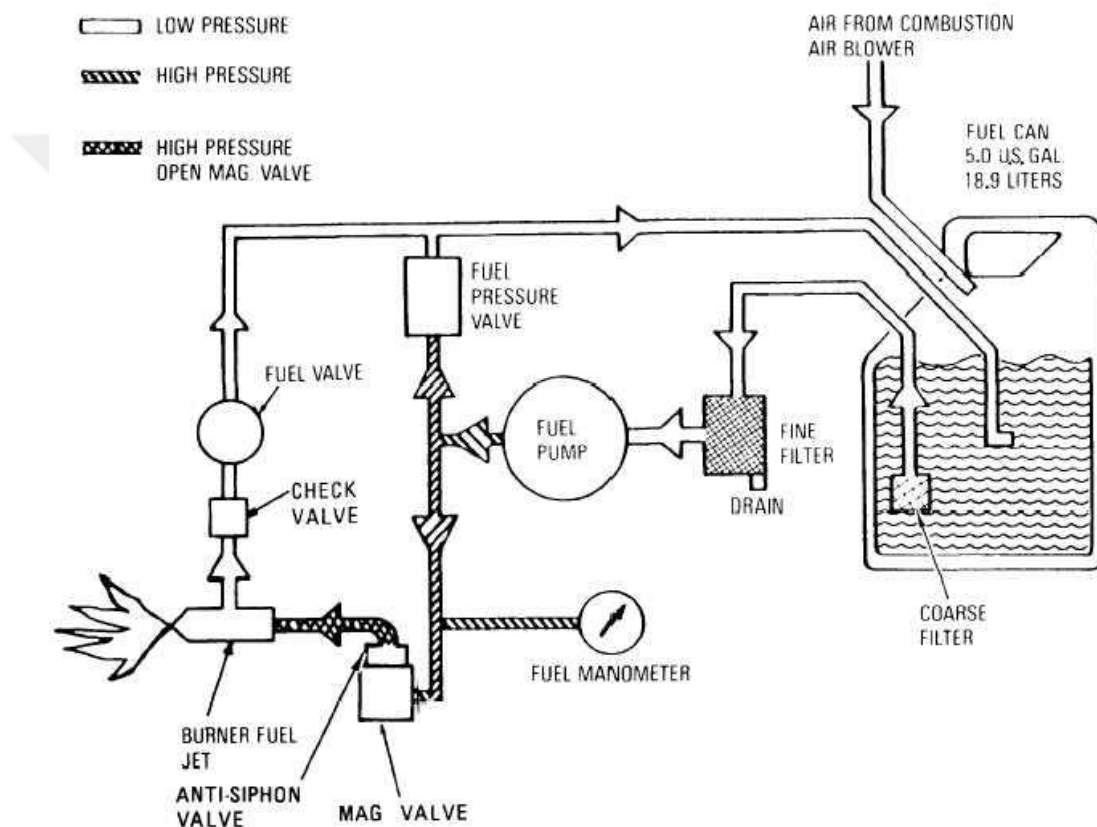

Figure 3.24. Heater fuel system [11].

A secondary solenoid valve is fixed downside of the main fuel supply solenoid valve. It is part of a fuel control unit that also houses a pressure regulator valve and an additional fuel filter. The valve opens and closes on command from the combustion heater thermostat. During normal operation, the heater cycles on and off by opening and closing this solenoid at the entrance to the combustion chamber. When opened, fuel flows through a nozzle that sprays it into the combustion chamber. Gravity is used to ensure that enough fuel flows to the combustion tank, or a small pump is

used and uses the same fuel as the engines of the aircraft. The fuel is forced in force to pass through filters to remove all small and large Western impurities from the system. In the event that these impurities are not completely removed from the fuel, they cause the heating system to shut down or stop completely. When the fuel filtration process ends, it is directed to the spray nozzle through the solenoid valve inside the combustion chamber. There are many shapes and sizes of spray nozzles that work to keep the amount of mist entering the combustion chamber. All types of spray nozzles provide the combustion chamber with a fixed amount of fuel to suit the amount of air entering in constant proportions. When this mixture of fuel and air is ignited at constant proportions, heating is produced in specified quantities. In the case of an increase in the desire for the amount of heat compared to the size of the plane, he uses a combustion heater of a larger size or uses a larger number of net heaters. When the temperature inside the plane increases more than required, the combustion heater is turned off or on for short periods. There is a temperature sensor installed inside the cabin of the plane that connects directly to the magnetic valve controlling the fuel stream to open and close the heating system the amount of fuel entering the heating system to control temperatures according to the pilot's control. In all combustion heater systems that contain a high temperature sensor installed at the fuel stream in each heater to ensure that the fuel stream closes in time in the event of high temperatures to dangerous levels. This type of sensor works automatically to separate the fuel in emergency situations to prevent combustion in the plane while flying in the air.

### **3.21. THERE ARE SEVERAL WAYS TO INSERT COMBUSTION FUEL INTO A COMBUSTION HEATER IN SEVERAL WAYS**

- Spray the fuel through the spray nozzle
- The spray nozzle is fixed in front of the airway to produce a constant-volume spray, then ignite it with a spark
- Transfer the fuel vapor into the combustion chamber

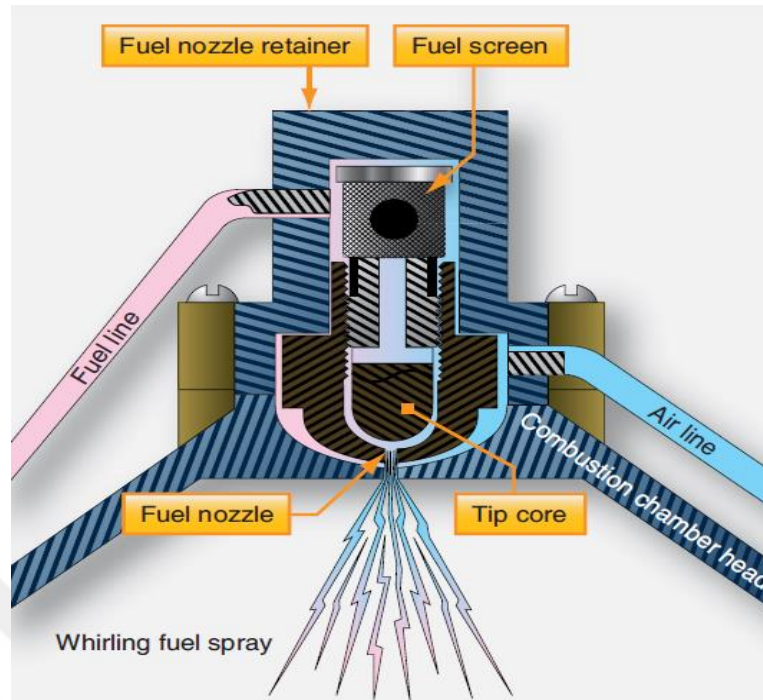

Figure 3.25. A spray nozzle [11].

The steam fuse is made of asbestos, which consists of a circular mouth or of reinforced iron that resists the rust. The last form is shown in the figure.

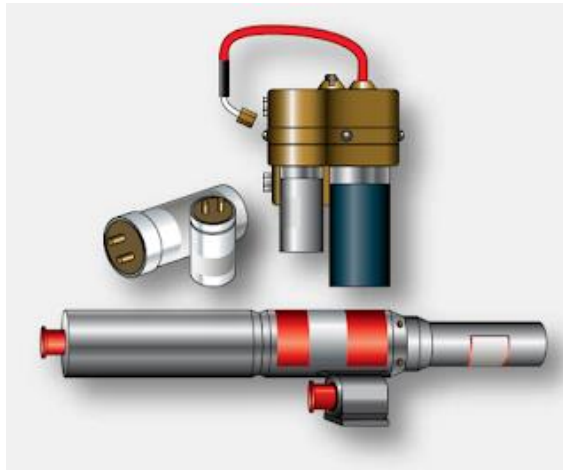

Figure 3.26. A vapor wick [11].

Tip core Whirling fuel spray Combustion fuel Spray chamber head typical heater spray nozzle assembly. A preheater, in the form of an electrical wire coiled around the fuel line, is used with some heaters "as the heater in our project" having a vapor wick. It warms the fuel to speed vaporization and aids ignition when the outside

temperature is below zero, its use is usually limited to 2min, because longer operation would damage the wire coil.

### **3.22. DESCRIPTION AND HOW THE IGNITION SYSTEM WORKS**

The fuel is ignited inside the combustion heater using the combustion candle, as the electrical voltage in the plane weakens to produce a jumping spark inside the combustion chamber. In the past there are some ancient types such as the vibration unit or in modern units that use electronic ignition. When the switch is placed inside the cabin of the aircraft, the ignition continues to operate until the combustion process is completed. A fan is used to pump enough ram air into the combustion chamber, as well as combustion fuel, and the appropriate user type should be observed according to the maintenance instructions. The voltage of the spark plug operation is as follows:

- The voltage surge unit connected to the 28 volt battery.
- Transformers for voltage connected to a 115 volt battery.

In batteries 28 volts of constant current, the voltage is raised using the pressure lift unit. The voltage consisting of a vibrator coil connected to an ascending coil producing a high voltage. The spark plug consists of the protected lead connected to the mounting coil of the spark plug at the center. When the luggage is placed on the operating position in the cabin, the voltage is raised, and then the electric spark jumps and this generates fuel ignition inside the combustion chamber. There is no difference in the use of spark spark candle in relation to the battery type AC or DC.

### **3.23. TYPES OF SPARK PLUGS**

Aircraft spark plugs used for the small engine usually same spark plugs used in the piston engine.





Figure 3.27. Spark plugs [11].

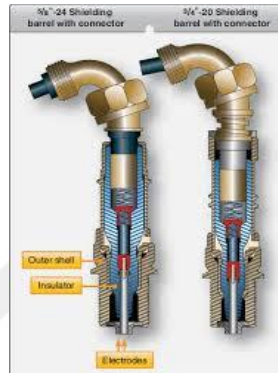

Figure 3.28. Spark plugs [11].

The main element on which the spark plugs are arranged is the arrangement of the electrodes.



Figure 3.29. Electrode sparkplug [11].



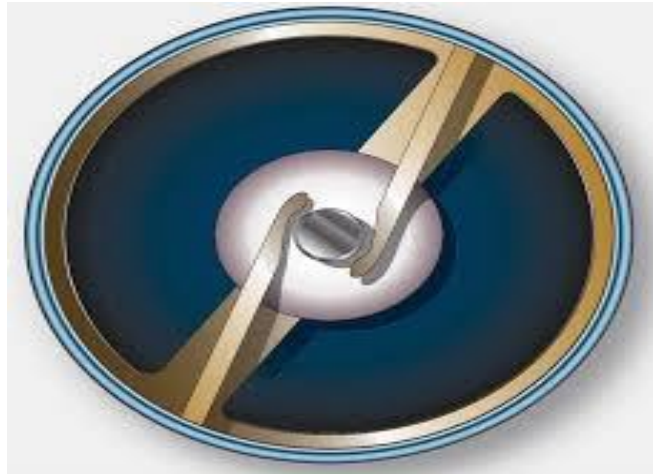

Figure 3.30. Shielded electrode plugs [11].



Figure 3.31. A single electrode [11].

### **3.24. HOW TO CONTROL THE HEATING SYSTEM AND ITS DIVISIONS**

When starting the combustion heater using an electric switch in the cabin, the fuel pump starts pumping the fuel needed for the combustion process also, the fan responsible for pumping sufficient amount of ram air inside the combustion chamber to start the combustion process and heating the air to raise the temperature of the plane. There is an additional fan to pump the air ventilation inside the plane in the event that the plane is in a position on the ground.



Figure 3.32. Cabin heat switch [10].

The system feeder fuel valve opens to start in operation when the thermostat sends a signal to start in the heating process. The start of the combustion process begins with the distribution of the required heat according to the degrees regulated inside the plane.

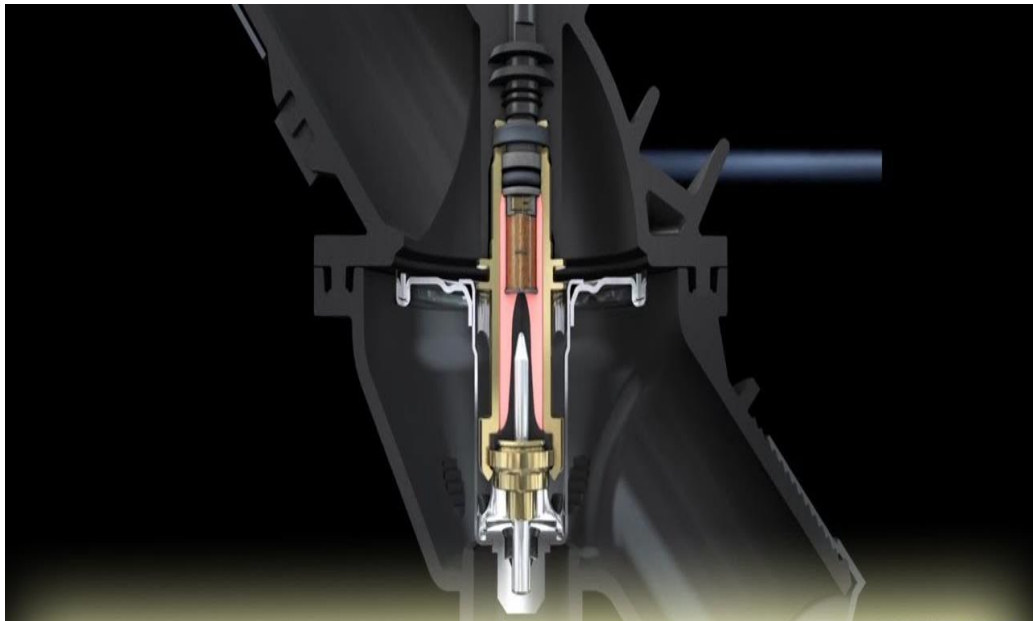

Figure 3.33. Thermostat [10].

The combustion heater operates according to calculated temperatures when the temperature rises more than necessary. The fuel pump is locked, so the heater stops working, and if the temperatures drop, the operation starts once again.

### **3.25. INSTALLATION, MAINTENANCE AND ADJUSTMENT**

#### **3.25.1. Installation**

Before installation the system to the aircraft, combustion heaters should be inspected and tested when necessary pressure tested in the manner prescribed in the manufacture maintenance manual to ensure that no fuel or gasses and combustion products leak into the cabin air supply ducts. Combustion heaters should be installed in the aircraft as manner specified in the maintenance manual concerned, we have to be sure that air and fuel leakage do not occur at duct joints or connection between the combustion heater system air cabin air supplies and no leakage of air or exhaust gas into the aircraft body. Equipment that associated with the combustion heating system such as air flow valves, air regulators, thermostatic devices and ducts should be correctly inter connected and mechanical movements, flow, and temperature degree setting checked.

#### **3.25.2. Typical Inspection**

Typical inspection should do for a combustion heater system include a visual inspection of the ducting and chamber for obstruction and condition. Inspection of the igniter plug for condition gap, and operation, and remove the rust, a check for any leakage in the airflow ducts or fuel system lines. A proper check of individual system components and an operational check of the complete system efficiency refer to the aircraft maintenance manual for specific inspection requirements for a particular model aircraft and heater that used.

**Definition:**

The combustion heater, which covered, by our report has the following to operate:

- Rated out 27. 500 BTU /HR a British thermal unit preheat.
- Rated fuel pressure 1 minimum-15 maximum p. s. i.
- Voltage 12 V. DC
- Ampere starts 12 run-7.

Our project manufactured by steward - Warner corporation- South wind division. It is installed on twin-engine light aircraft Piper aircraft CO in the left side of the nose section.

**3.26. SAFETY CONSIDERATIONS**

There are several safety systems in the combustion heater system to ensure that no serious aircraft accidents occur during the flight process. The fuel pump lockout switch turns off the fuel flow in the absence of sufficient combustion process. The temperature sensor works when the temperatures rise above the required limit. The sensor closes the entire system in this case to prevent a fire in the plane. When the combustion heater stops for any safety tool, the heater has to return to work again until the heater undergoes a process of detection or maintenance [4].

**3.27. NATURAL GAS**

Generally, in heat processing system need to use energy sources. Today many countries encourage the tendency of energy production to renewable resources. Natural gas is the efficient and effective alternative fuel into a low-carbon gas energy future. While the efficiency of renewable technology is constantly improving, it has yet to match the efficiency of natural gas in power generation. Natural gas enables renewables as it can be added to power generation facility at the right time and in the

appropriate volumes needed. To bequeath habitable environment, today's world has to pay more attention to safe energy sources and usages. This well-known truth forced to change the energy policies of entire world. Natural gas is a naturally occurring hydrocarbon used as a source of energy for heating, cooking, and electricity generation in home and industry uses. It is also used as a fuel for some kind of vehicles and as a chemical feedstock in the manufacture of plastics and other commercially important organic chemicals. Many environmentalists look to the natural gas as a natural bridge fuel between the dominant fossil fuels of today and the renewable fuels of future. For a given amount of heat energy, burning natural gas produces about half as much carbon dioxide, the main cause of global warming, as burning coal [11].

Some clear advantages to natural gas are as follows:

- Natural gas is environmentally friendly because when use it to burns in home or in industry cleaner than other fossil fuels.
- It is safer and easier to store when compared to other fossil fuels.
- Natural gas is extremely reliable at some dangerous condition, unlike electric power that can be knocked out during a storm.
- Natural gas has no color or odor.
- When it is burned, it gives off a lot of energy that can be used for cooking, heating, generating electricity and other necessities. However, because it is fossil fuel, natural gas is not a renewable resource. It produces less greenhouse gases than other fossil fuels do.

Combined heat and power (CHP) installations enable the utilization of more than 80% of the energy content in natural gas. , the average combined cycle natural gas plant is approximately 39 percent more efficient than the oldest 50 percent of existing coal generation capacity - and 58 percent more efficient than the oldest 10 percent of coal-fired plants. For the oldest power-generating facilities, 60% more coal needs to be burned to generate the equivalent power of a natural gas power generation plant.

### **3.28. USE NATURAL GAS IN AIRCRAFT HEATING SYSTEM**

All aircraft manufactures and designed planning still use aircraft fuel (gasoline) for combustion heating system. The main idea of this thesis is use natural gas instead of gasoline to activate the system with more efficiency, less cost low maintenance low control system component. Existing system use fuel lines and airlines for the mixture, so new system need gas lines only. Gasoline has some problem with low temperature which gasoline freezing point is (-20 C to -40 C) in other hand natural gas freezing point is (-296 C) that is mean very low freezing point. Old system is not safe in leak condition because all the burning gases will flow into the aircraft cabin in this case the pilot has not choice the plane must land. This point gives more advantage for natural gas uses, which is safe in leak condition. Old system always needs inspection and cleaning because of remnants of combustion gases and frame cracks to avoid areal plane accident. A bad thing is that spring and summer it can be difficult to get the temperature down to a comfortable level when on, while too cold to leave it off. Because the pilot cannot control fuel air ratio it is fixed in flight conditions and altitude, so with natural gas system will overcome this embarrassed defect during control a gas flow increase or decrease flow control valve. Fuel system use same plane engines main tank to feed combustion heater system due to this old way the fuel consumption calculation is not accurate, for example read this report from pilot Peter, I suspect that the consumption is 2. 25 pounds per hour. The 65Hp Cub I used to fly cruised on just over 3 GPH! From my Aztec days, and that one had two heaters) I recall that we considered heater fuel consumption to be negligible for flight planning purposes.

Perhaps more importantly, the heater consumption would make a mockery of the 1-2%-accurate fuel totalizer. There would be no way to check that it is accurate, with an error of that size creeping in. Natural gas cheap for long time use and easy to measure the gas quantity used. There is other advantage in natural gas list, the weight of natural gas mass is lighter than gasoline, in aviation design the weight of the aircraft very important to measure plane balance, so use lighter materials is important for aircraft efficiency. Consumption of natural gas is measured in cubic meters (m<sup>3</sup>) or cubic feet (cu. ft).

### 3.29. HOW TO MEASURE NATURAL GAS

Describing the amount of natural gas consumed in home or industry by an entire country or a single residential appliance can be confusing, since natural gas can be measured in several different ways.

Quantities of natural gas that used are usually measured in cubic feet. CRMU lists how much gas residential customers use each month in 100 cubic feet increments or (100 cubic feet – 1 hcf). For example, a typical natural gas futures contract is a financial instrument based on the value of about 10 million cubic feet (Mmcf) of natural gas.

The energy content of natural gas and other forms of energy (i. e. , the potential heat that can be generated from the fuel) is measured in BTUs (British thermal units). The number of "terms" that residential natural gas customers consume each month is approximately equal to hcf.

Here are some frequently used units for measuring natural gas:

1 cubic foot (cf) of fuel = 1,027 Btu = 1055, 06 joules

100 cubic feet (1 hcf) of fuel  $\times$  100 = 1 therm (approximate)

1,000 cubic feet (1 Mcf) of fuel  $\times$  1000 = 1,027,000 Btu (1 MMBtu)

1, 0000 cubic feet (1 Mcf) of fuel  $\times$  10000= 1 dekatherm (10 therms)

1 million (1,000,000) cubic feet (1 Mmcf) of fuel = 1,027,000,000 Btu

1 billion (1,000,000,000) cubic feet (1 bcf) of fuel= 1. 027 trillion Btu

1 trillion (1,000,000,000,000) cubic feet (1Tcf) of fuel = 1. 027 quadrillion Btu

To put this in context:

1,000 cubic feet of natural gas is approximately enough to meet the natural gas needs of an average air craft (space-heating, water-heating, cooking, etc. ) for 100 flight hours.

### **3.30. AVGAS HEATERS - FUEL CONSUMPTION**

Vaguely recall the Twin Comanche being half a gallon per hour, which seems to correspond with 2.25 PPH not too badly.

As I recall the heater fuel supply was before the totalizer in the fuel flow system, but that is recollection, not certainty. The manual of the Pa44 (the only janitor heater equipped plane I currently fly) states „approximately 1/2 gallon per hour“. That would make around two liters per hour compared to 40-50 liters per engine per hour. Which is around two percent of the total fuel consumption, well within the 5 to 15 percent (depending on the type of operation) contingency margin that needs to be applied to the fuel calculation any way. 5 USG is half an hour in cruise, for me, I would not be landing with just half an hour in the tanks, but for me this amount of fuel would be significant. And I expect the fuel flow into the heater won't be constant; doesn't it adjust the fuel flow to achieve a given cabin temperature? Or is the cabin temperature adjusted by the heater running flat out all the time, and then there is a ram air / heated air mixer valve?

In a SE, one could take care of the heater fuel flow by buying a fuel totalizer for a twin and feeding the heater via the "second engine" flow sensor, but I do not think anybody makes 3-sensor totalizers.

At full heat, you can bake muffins in the cabin.

### **3.31. NATURAL GAS DEFINITION AND CALCULATION**

Pure methane is a molecule made up of one Carbon atom and four Hydrogen atoms and is referred to as CH<sub>4</sub>

### **3.32. HOW TO CALCULATE NATURAL GAS CONSUMPTION**

In a gas burner one cubic foot of natural gas consumption = 1075 BTU of energy.



- Conversion factor of natural gas 1000 LP =39 percent efficient.
- Divide the BTU output by the approximate conversion factor.

### 3.33. EXACT GAS CONSUMPTION

- Multiply the burner efficiency by the energy contents the gas being used. Natural gas contains 1075 BTU per cubic foot.
- Adjust for the burner efficiency by dividing rating. For example for burner that is 95- percent efficiency divided by 0, 85.

In the example : 40000 BTU divided by 1,075=37,21 divided by 0,95=39,17 cubic feet of natural gas consumed in one hour [9].

$$\frac{\text{British thermal unit}(BTU)}{\text{Fuel energy content}} = \text{Fuel consumption In cubic feet}$$

$$\frac{40000 BTU}{1075} = 37,21(L, CF)$$

$$\frac{\text{Fuel consumption in cubic feet}}{\text{percentage}} = \text{burner efficiency}$$

$$\frac{37,21(L, CF)}{95\%} = 39,17(CF) \text{ of natural gas consumed in one hour}$$

### 3.34. BRITISH THERMAL UNIT (BTU) DEFINITION

Amount of the heat required to raise the temperature of one pound of water at or near 39,2 degrees Fahrenheit or 4 Celsius.

1 cubic feet (Ccf) natural gas = 1,027 BTU constant

100 cubic feet (Ccf) natural gas = 103,700 BTU

100 cubic feet (Ccf) natural gas  $\times$  1,027 =103,700 BTU

1000cubic feet (Ccf) natural gas $\times$  1000 = 1,027000 BTU

### **3.35. HOW DO MEASURE NATURAL GAS**

A cubic foot of gas is the amount of gas needed to fill a volume of one cubic foot under set condition of pressure and temperature. To measure large amount of natural gas a Term is used to denote 100 cubic feet. And (mcf) is used to denote 1000cubic feet.

### **3.36. HOW NATURAL GAS PRESSURE CALCULATE**

Can measure in two ways:

Pound per square inch (psi) or inches of water column. In this pressure is around 2psi inches of water column is typical used to measure low pressure gas system.

### **3.37. WHAT IS THE FORMULA THAT USED TO CALCULATE NATURAL GAS CONSUMED**

For a burner that is 95 percent divided by 0, 95 in the example. 40000 BTU divided by 1,075 = 37, 21. Adjusting for burner efficiency. 37. 21 divided by 0, 95 =39, 17 cubic feet of natural gas consumed in one hour [9].

### **3.38. GAS BURNER CONSUME FUEL BASED ON THEIR (BTU) OUTPUT**

One cubic –foot of natural gas contain 1075 BTU of energy.

Natural gas contains 1075 BTU per cubic foot CONSTANT.

The output will be in BTU for example 40000 BTU.

Divided the BTU per hour by the fuel energy content.

40000 BTU divided by 1075 = 37, 21 cubic feet of gas per hour at 100 percent efficiency.

IN 95 percent efficient:

40000BTU divided by 1075 =37,21 adjusting for burner efficiency = 37,21 divided by 0,95 =39,17 cubic feet of natural gas consumed in one hour.

### 3.39. FUEL HEATING SYSTEM

1 BTU = 1055, 06 JOULS

1 gallon US of fuel =115000 BTU constant = 121331900 Joules

3, 78541 Liter of fuel = 115000 BTU constant =115000 BTU constant = 121331900 Joules

1 Liter of fuel = 0,264 gallon =3038800 BTU constant =3206116 Joules

10 L× 3038800 =30038800 BTU per hour = 105506 Joules

20 L× 3038800 =60038800 BTU per hour = 6334455 Joules

30 L× 3038800= 90038800 BTU per hour = 91164000 Joules

Comparative thermal value of fuel and equals in BTU.

Table of Comparative Thermal Values of Fuels

Table 3.1. Table of comparative thermal values of fuels [9].

<b>THERMAL VALUE</b>	<b>1,000,000 BTU 1 MMBTU</b>	<b>24,000,000 BTU 24 MMBTU</b>	<b>91,600 BTU 91.6 MBTU</b>	<b>125,000 BTU 125 MBTU</b>	<b>139,000 BTU 139 MBTU</b>	<b>150,000 BTU 150 MBTU</b>	<b>3,412,000 BTU 3.412 MMBTU</b>
<b>NATURAL GAS 1,000 BTU/CU FT.</b>	<b>1,000 cu ft 1 Mcf</b>	24,000 cu ft 24 Mcf	91.6 cu ft	125 cu ft	139 cu ft	150 cu ft	3,412 cu ft
<b>COAL 12,000 BTU/LB</b>	83.333 lbs	<b>2,000 lbs 1 ton</b>	7.633 lbs	10.417 lbs	11.583 lbs	12.5 lbs	284.3 lbs
<b>PROPANE 91,600 BTU/GAL</b>	10.917 gal	262 gal	<b>1 gal</b>	1.365 gal	1.517 gal	1.638 gal	37.3 gal
<b>GASOLINE 125,000 BTU/GAL</b>	8 gal	192 gal	0.733 gal	<b>1 gal</b>	1.112 gal	1.2 gal	27.3 gal
<b>FUEL OIL #2 139,000 BTU/GAL</b>	7.194 gal	172.662 gal	0.659 gal	0.899 gal	<b>1 gal</b>	1.079 gal	24.5 gal
<b>FUEL OIL #6 150,000 BTU/GAL</b>	6.666 gal	160 gal	0.611 gal	0.833 gal	0.927 gal	<b>1 gal</b>	22.7 gal
<b>ELECTRICITY 3,412 BTU/kWh</b>	293.083 kWh	7034 kWh	26.846 kWh	36.635 kWh	40.739 kWh	43.962 kWh	<b>1,000 kWh 1 MW</b>

To explain the relation between the natural gas and gasoline conception and cost I used this table for make it easy.

This table gives the relation between natural gas in minimum, maximum efficiency and cost with constant area.

1 BTU = 1055, 06 JOULS

Table 3.2. The relationship between gases consumed and cost with change in areas.

<b>Area (Cuf)</b>	<b>Min Heat Efficiency (BTU)</b>	<b>Min GAS concept ion feet</b>	<b>Min GAS concept ion C letter</b>	<b>Max GAS concept ion C feet</b>	<b>Max GAS concept ion C letter</b>	<b>Min gas cost \$</b>	<b>Max gas cost \$</b>
35.0	800.0	0.8	22.0	2.2	63.2	0.004	0.012
40.0	900.0	0.9	24.7	2.4	68.7	0.005	0.013
45.0	1000.0	1.0	27.5	2.7	77.0	0.005	0.015
50.0	1100.0	1.1	30.2	3.0	85.2	0.006	0.016
55.0	1200.0	1.2	33.0	3.3	93.5	0.006	0.018
60.0	1300.0	1.3	35.7	3.6	101.7	0.007	0.019
65.0	1400.0	1.4	38.5	3.9	110.0	0.007	0.021
70.0	1500.0	1.5	41.2	4.2	118.2	0.008	0.023
75.0	1600.0	1.6	44.0	4.5	126.5	0.008	0.024
80.0	1700.0	1.7	46.7	4.8	134.7	0.009	0.026
85.0	1800.0	1.7	49.5	5.0	143.0	0.009	0.027
90.0	1900.0	1.8	52.2	5.3	151.2	0.010	0.029
95.0	2000.0	1.9	55.0	5.6	159.5	0.011	0.031
100. 0	2100.0	2.0	57.7	5.9	167.7	0.011	0.032

The differences between the natural gas and gasoline cost will be clearer when we use the diagram with table.

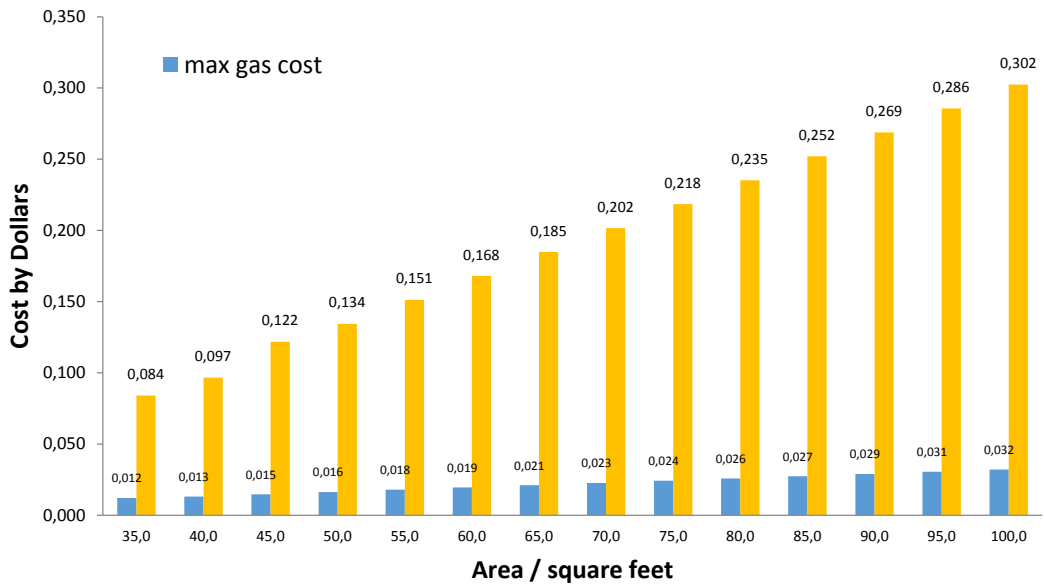

Figure 3.34. The relationship between gas and gasoline maximum efficiency with change in areas.

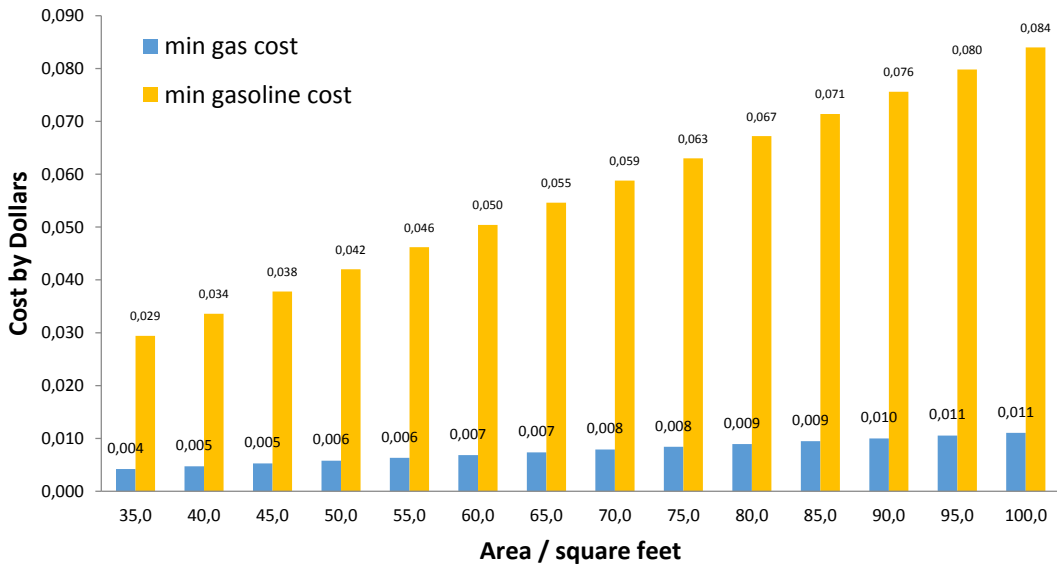

Figure 3.35. Relationship between gas and gasoline minimum efficiency with change in areas

Table 3.3. The relation between gasolines with change of areas.

<b>Area (Cf)</b>	<b>Min heat efficiency (BTU)</b>	<b>Max heat efficiency (BTU))</b>	<b>Min fuel conception letter</b>	<b>Max fuel conception letter</b>	<b>Min gasoline cost</b>	<b>Max gasoline cost \$</b>
35.0	700.0	2000.0	0.021	0.061	0.029	0.084
40.0	800.0	2300.0	0.024	0.070	0.034	0.097
45.0	900.0	2600.0	0.027	0.089	0.038	0.122
50.0	1000.0	2900.0	0.031	0.098	0.042	0.134
55.0	1100.0	3200.0	0.034	0.110	0.046	0.151
60.0	1200.0	3500.0	0.037	0.122	0.050	0.168
65.0	1300.0	3800.0	0.040	0.134	0.055	0.185
70.0	1400.0	4100.0	0.043	0.147	0.059	0.202
75.0	1500.0	4400.0	0.046	0.159	0.063	0.218
80.0	1600.0	4700.0	0.049	0.171	0.067	0.235
85.0	1700.0	5000.0	0.052	0.183	0.071	0.252
90.0	1800.0	5300.0	0.055	0.195	0.076	0.269
95.0	1900.0	5600.0	0.058	0.208	0.080	0.286
100.0	2000.0	5900.0	0.061	0.220	0.084	0.302

## **CHAPTER 4**

### **CONCLUSION**

The adjustment of temperature, pressure, humidity, and oxygen intensity of the aircraft cabin is important for human live when the flight conditions of a commercial aircraft are taken into account. Health problems especially for passengers on board could be seen due to adverse conditions. That is why; hot and pressurized air obtained from aircraft engine compressor zones is conditioned in the air-conditioning system to present comfortable ambience inside of the aircraft cabin. In present study. Combustion heater system is considered one of the internationally approved systems in the heating process used in small and medium-sized civil aircraft. It works independently of the main engines in the plane and uses the same gasoline. Combustion heater system is widely used to produce main heating source for crew and passenger. All the combustion heaters use gasoline air mixture for combustion energy. The kind of fuel that is used in aircraft is expensive and has some problems when flight in under freezing temperature. This mixture flow is fixed in all flight conditions because the system does not have fuel flow control. To control fuel air mixture requires a special system. This special system might be Carburetor system or Injection system. Therefor the system would be more complicated, requires more maintenance and more occurred defects in flight. Thus, combustion heater system needs to use different source of energy to overcome the disadvantages of gasoline system and allow the system to control the energy flow by less complicated method. The natural gas might be the best alternative energy that give the heating system same efficiency, low cost, less weight more safe less fuel consumption and the cabin can control the gas flow as passenger wishes according to the ambient temperature.

The gas control valve use to adjust the gas flow which allow the system to change the air craft temperature according to the altitude and the ambient temperature. According to the cost calculation between natural gas consumption and gasoline consumption there are a different in the cost. Actual freezing temperature of water (-0), In other hand the actual freezing temperature of gasoline(-20 – -40), natural gas(-256) the very low freezing point of natural gas gave the heating system ability to work in all flight altitude safely. The combustion heater is necessary and very important To heat the cabin of aircraft that flight in high altitude and in cold weather to make comfortable condition and interior environment for the crew, passenger and other compartment. , therefore it should be operated properly, inspected carefully, And tested frequently on ground to avoid failure during flight, And to eliminate the risk of the cabin air supply becoming contaminated. is hoped that teachers and students benefit from the suggested approach of this report and understand it.



## REFERENCES

1. Exhaust Gases From Combustion and Industrial Processes, "EPA Contract No. EHSD 71-36", *Engineering Science, Inc.*, Washington, DC, 10-14 (1971).
2. Perry, J. H., "Chemical engineers' handbook", *McGraw-Hill Book Company*, New York, 30-32 (1963).
3. Background Information Document for Industrial Boilers, "EPA 450/3-82-006a", *U. S. Environmental Protection Agency*, Washington, 20-25 (1982).
4. Muhlbaier, J. L., "Particulate and gaseous emissions from natural gas furnaces and water heaters", *Journal of the Air Pollution Control Association*, 31(12): 1268-1273 (1981).
5. Čavka, I., Čokorilo, O., and Vasov, L., "Energy efficiency in aircraft cabin environment: Safety and design", *Energy and Buildings*, 115(1): 63-68. (2016).
6. Sinnott, R., "Safety and security in building design", *Collins*, London, 30-33 (1985).
7. Manual, A. F., "Department of transportation federal aviation administration", *McGraw-Hill Book Company*, New York, 40-45 (2012).
8. Ozdemir, Y., Ozgoren, M., and Goktepel, I., "Energy Analysis for an Air-Conditioning System of a Commercial Aircraft: Case Study for Airbus A330", *International Journal of Energy Applications and Technologies*, 3(2): 60-67 (2016).
9. Hocking, M. B., "Trends in cabin air quality of commercial aircraft: industry and passenger perspectives", *Reviews on Environmental Health*, 17(1): 1-50 (2002).
10. Cakir, K., Ocal, M. and Taymaz, I. "An air-conditioning system in the commercial aircrafts and comfort", *Sakarya University Journal of Science*, 7(1): 229-235 (2003).

11. Arslan, B., Karakoc, T. Yoru, H. and Altuntas, O., “Aircraft systems and indoor air quality on climate effects”, *Engineer and Machine*, 51(5): 9-19 (2010).
12. Dumas, A., Angeli, D., and Trancossi, M., “High altitude airship cabin sizing, pressurization and air conditioning”, *Energy Procedia*, 45(3): 977-986 (2014).
13. Chen, J., Wang, W., Qu, M., & Yin, W., “Study on Hot Air Distribution of Ship Cabin Air-Conditioning”, *Procedia Engineering*, 121(3): 1420-1427 (2015).
14. Oliveira, J. L. G., Tecchio, C., Paiva, K. V., Mantelli, M. B. H., Gandolfi, R., & Ribeiro, L. G. S., “Passive aircraft cooling systems for variable thermal conditions”, *Applied Thermal Engineering*, 79 (2): 88-97 (2015).
15. Yang, S., Sun, X. Yu, T. and Chen, X. “Research on the numerical simulation of aircraft cabin smoke,” *Procedia Engineering*, 121(4): 357-364 (2015).
16. Yao, Z., Zhang, X., Yang, C., and He, F., “Flow characteristics and turbulence simulation for an aircraft cabin environment”, *Procedia Engineering*, 121(6): 1266-1273 (2015).
17. Unumulta, I. S., “Sector-Specific Issues and Reporting Methodologies Supporting the General Guidelines for the Voluntary Reporting of Greenhouse Gases under Section 1605 (b) of the Energy Policy Act of 1992”, *United States Department of Energy*, Washington, 205-285 (1994).
18. Internet: Key World Energy Statistics 2013, [http://www.iea.org/publications/free\\_publications/publication](http://www.iea.org/publications/free_publications/publication) / (2013).
19. Internet: Japan’s Burning Hope for New Energy, <http://news.Nationalgeo.com/news/energy2013/03/pictures/130328methane-hydrates-for-energy> / (2013).
20. Pérez-Grande, I., & Leo, T. J., “Optimization of a commercial aircraft environmental control system”, *Applied Thermal Engineering*, 22(17): 1885-1904 (2002).
21. Leo, T. J., and Pérez-Grande, I., “A thermos economic analysis of a commercial aircraft environmental control system”, *Applied Thermal Engineering*, 25(2-3): 309-325 (2005).
22. Fortin, G., Laforte, J. L., and Ilinca, A., “Heat and mass transfer during ice accretion on aircraft wings with an improved roughness model”, *International Journal of Thermal Sciences*, 45(6): 595-606 (2006).
23. Saeed, F., “State-of-the-art aircraft icing and anti-icing simulation”, *ARA Journal*, 20(25-26): 106-113 (2003).

24. Eckersley, N., “Advanced mercury removal technologies”, *Hydrocarbon processing*, 89(1): 29 (2010).
25. Internet: Natural gas Companies <http://www.energyandcapital.com/resources/natural-gas-companies/>(2010).
26. Bourke, M. J., & Mazzoni, A. F., “The roles of activated carbon in gas conditioning”, *In Laurence Reid Gas Conditioning Conference*, Norman, 23-31 (1989).
27. Ebinghaus, R., Turner, R. R., de Lacerda, L. D., Vasiliev, O., and Salomons, W., “Mercury contaminated sites: characterization, risk assessment and remediation”, *Springer Science and Business Media*, Bern, Switzerland, 35-40 (2013).
28. Gas, P. Q. N., “Natural gas processing: the crucial link between natural gas production and its transportation to market”, *Los Alamos*, New Mexico, USA, 20-22 (2006).
29. Internet: Natural Gas Supply Association, [http://www.naturalgas.org/overview/unconvent ng resource.asp](http://www.naturalgas.org/overview/unconvent_ng_resource.asp) / (2011).
30. Sered, Y., and Reich, Y., “Standardization and modularization driven by minimizing overall process effort”, *Computer-Aided Design*, 38(5): 405-416 (2006).
31. Internet: Gas and LNG Industry Glossary, Alphanat Training, <http://www.gasstrategies.com/industry-glossary> / (2013).
32. Sakib, M. N., Mohammad, N., Barua, N., and Amin, M. R., “Flow Sheet Development and Simulation with Optimization of Industrial Scale Natural Gas Processing Plant by Using Aspen-Hysys”, *Science Direct*, 5(3): 84-86 (2002).
33. Mehra, Y. R., “Market-driven evolution of gas processing technologies for NGLs”, *Chemical Technology-Bedford View*, 4(6): 34-38 (2007).
34. Natural Gas Physical and Engineering Data, “Shell Companies in Malaysia”, *Shell Company Report*, Kuala Lumpur, Malaysia, 22-27 (1983).
35. Internet: Authority for electrical energy and gas, [www.autorita.energia.it/](http://www.autorita.energia.it/) (2002).
36. Le Corre, O., and Loubar, K., “Natural gas: physical properties and combustion features”, *In Natural Gas*, Washington, 207 (2010).
37. Estela-Uribe, J. F., and Jaramillo, J., “Generalised virial equation of state for natural gas systems”, *Fluid Phase Equilibria*, 231(1): 84-98 (2005).

## **RESUME**

Aiuob Sahboun was born in Tripoli in 1976 and he graduated first and elementary education in this city. He completed high school education in Hy Alandalus High School, after that, he started undergraduate program in Civil Aviation University - Libya Department of Gas-Turbine Engine in 1998. Then in 2008, he started Teacher assistant at Al-Mergeb University Department of Mechanical Engineering. To complete M. Sc. education, he moved to Karabük University in 2017.

### **CONTACT INFORMATION**

Address: Karabük University  
Graduate School of Energy Systems Engineering  
Demir-Çelik Campus/KARABUK

E-mail : [aiuob76@gmail.com](mailto:aiuob76@gmail.com)