



**DESIGN AN ENERGY CONSUMPTION CLUSTERING METHOD FOR
HETEROGENEOUS WIRELESS SENSOR NETWORKS**

SUDAD GHARIB HASSAN

AUGUST 2015

**DESIGN AN ENERGY CONSUMPTION CLUSTERING METHOD FOR
HETEROGENEOUS WIRELESS SENSOR NETWORKS**

**A THESIS SUBMITTED TO
THE GRADUATE SCHOOL OF NATURAL AND APPLIED
SCIENCES OF
ÇANKAYA UNIVERSITY**

**BY
SUDAD GHARIB HASSAN**

**IN PARTIAL FULFILLMENT OF THE REQUIREMENTS FOR THE
DEGREE OF
MASTER OF SCIENCE
IN
THE DEPARTMENT OF
MATHEMATICS AND COMPUTER SCIENCE/
INFORMATION TECHNOLOGY**

AUGUST 2015

Title of the Thesis : **Design an Energy Consumption Clustering Method for Heterogeneous Wireless Sensor Networks.**

Submitted by **Sudad Gharib HASSAN**

Approval of the Graduate School of Natural and Applied Sciences, Çankaya University.

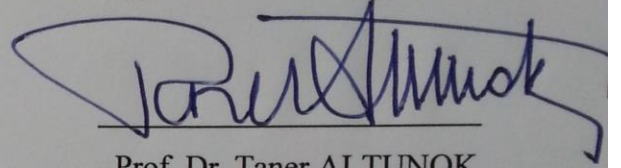

Prof. Dr. Taner ALTUNOK
Director

I certify that this thesis satisfies all the requirements as a thesis for the degree of Master of Science.

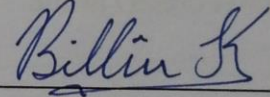

Prof. Dr. Billur KAYMAKÇALAN
Head of Department

This is to certify that we have read this thesis and that in our opinion it is fully adequate, in scope and quality, as a thesis for the degree of Master of Science.

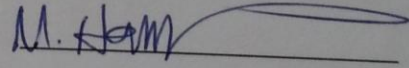

Prof. Dr. Mahir NAKIP
Supervisor

Examination Date: 05.08.2015

Examining Committee Members:

Prof. Dr. Mahir NAKIP

(Çankaya Univ.)

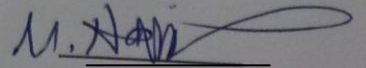

Assoc. Prof. Dr. Reza Hassan Pour

(Çankaya Univ.)

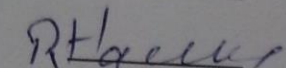

Assoc. Prof. Dr. Fahad Jarad

Turkish Aeronautical
Association Univ.

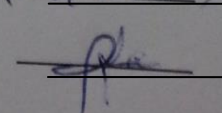

STATEMENT OF NON-PLAGIARISM PAGE

I hereby declare that all information in this document has been obtained and presented in accordance with academic rules and ethical conduct. I also declare that, as required by these rules and conduct, I have fully cited and referenced all material and results that are not original to this work.

Name, Last Name : Sudad Gharib HASSAN

Signature : 

Date : 05.08.2015

ABSTRACT

DESIGN AN ENERGY CONSUMPTION CLUSTERING METHOD FOR HETEROGENEOUS WIRELESS SENSOR NETWORKS

HASSAN, Sudad

M.Sc., Department of Mathematics and Computer Science/
Information Technology

Supervisor: Prof. Dr. Mahir NAKIP

August 2015, 41 pages

In this thesis it used clustering method for saving energy in wireless sensor networks. It separates the energy of sensors to 3 parts. Some of these sensors have less than the half of energy ($0.5E_0$), some of them has more than half and less than the E_0 and last remain sensors has greater than the E_0 . LEACH provides a random clustering method but there are some constraints that affect the clustering algorithm such as definition of number of clusters in each round.

Keywords: Clustering, Energy Consumption, Wireless Sensor Network, Heterogeneous.

ÖZ

HETEROJEN KABLOSUZ SENSÖR AĞLARI İÇİN KÜMELEME YÖNTEMİ İLE BİR ENERJİ TÜKETİMİ TASARIMI

HASSAN, Sudad

Yüksek Lisans, Bilişim Teknoloji Anabilim Dalı

Tez Yöneticisi: Yar. Doç. Dr. Mahir NAKIP

Agustos 2015, 41 sayfa

Bu tezde, kablosuz algılayıcı ağlar enerji tasarrufu için kümeleme yöntemi kullanılır. 3 parçalara sensörlerin enerji ayırın. Bu sensörlerin bazıları enerjinin yarısından ($0.5E_0$) daha az olması, bazıları E_0 yarısından az daha var ve son sensörler E_0 daha fazla sahip olmaya devam etmektedir. LEACH rastgele kümeleme yöntem sağlar ama böyle her turda kümelerin sayısının tanımı olarak kümeleme algoritması etkileyen bazı kısıtlamalar vardır.

Anahtar Kelimeler: Kümeleme, Enerji Tüketimi, Kablosuz Sensör Ağı, heterojen.

ACKNOWLEDGEMENTS

I would like to express my appreciation to my great supervisor, Prof. Dr. Mahir NAKIP, Assoc. Prof. Dr. Reza Hassan Pour and Assist. Prof. Dr. Özgür Tolga PUSATLI who gave me unlimited supporting and valuable guidance, suggestions there is no enough words to express thanks for them.

In addition, I want to express my deep gratitude to my dear father, mother, wife, and children (Firdows and Yusuf). Finally, thanks go to my sisters, brothers and all of my friends for their endless and continuous encouragement and support throughout the years.

TABLE OF CONTENTS

STATEMENT OF NON PLAGIARISM.....	iii
ABSTRACT.....	iv
ÖZ.....	v
ACKNOWLEDGEMENTS.....	vi
TABLE OF CONTENTS.....	vii
LIST OF FIGURES.....	ix
LIST OF TABLES.....	x
LIST OF ABBREVIATIONS.....	xi

CHAPTERS:

1. INTRODUCTION.....	1
1.1. Introduction.....	1
1.2. Wireless Network Clustering.....	3
1.3 Wireless Sensor Network Clustering Applications	4
1.4. Outline of the Thesis.....	6
2. LITTERATURE SURVE.....	7
2.1. Introduction.....	7
2.2. Sensor Placement.....	7
2.3. Sensor Activity Scheduling.....	9
2.4. Data Routing.....	10
2.5. Sink Location.....	12
2.6. Works That Integrate Some of the Design Issues.....	13
2.7. Low-Energy Adaptive Clustering Hierarchy (LEACH).....	14
2.8. Hybrid Energy Efficient Distributed (HEED).....	17
2.9. Energy Efficient Hierarchical Clustering (EEHC).....	18
2.10 Distributed Weight-Based Energy-Efficient Hierarchical Clustering (DWEHC).....	18
3. WIRELESS SENSOR NETWORKS ROUTING ALGORITHMS	20
3.1. Research Groups and Projects for Wireless Sensor Networks.....	20

3.2. Classification of Wireless Sensor Networks Routing Algorithms	20
3.3. Routing Algorithms in the Literature	21
3.3.1. Sensor Protocols for Information via Negotiation	21
3.3.2. Directed Diffusion	23
3.3.3. Rumor Routing	24
3.3.4. Altruistic Energy Aware Routing Protocol	24
3.3.5. Geographical and Energy Aware Routing (GEAR).....	25
3.4. Energy Dissipation	26
3.5. Beaconing.....	27
3.5.1. Data Aggregation Method	28
3.5.2. Routing in WSNs	28
3.5.2.1. Reactive Routing.....	28
3.5.2.2. Hierarchical Routing	29
4. PROPOSED METHOD	30
4.1. Network Model	30
4.2. The Proposed Method.....	32
4.3. 4.2.1. Initial Phase	32
4.2.2. Setup Phase	33
4.2.3. Cluster Head Selection	33
4.2.4. Development Generating	35
4.2.5. Steady-state Phase	35
4.3. Evaluation of Performance.....	35
4.3.1. Performance Parameters	35
4.3.2. Simulation Results and Analysis	36
4.3.3. Network Lifetime	36
5. CONCLUSION	41
REFERENCES.....	R1
APPENDIX.....	A1
A. CURRICULUM VITAE.....	A1

LIST OF FIGURES

FIGURES

Figure 1	Implosion Problem: A's Information is Sent to D from Both B and C [26]	22
Figure 2	Overlap Problem: C Receives Information of Region r from Both A and B [26]	22
Figure 3	Simple Radio Energy Model [53].....	27
Figure 4	Network Model Used in Proposed Method.....	30
Figure 5	Radio Model Employed in the proposed Algorithm.....	31
Figure 6	The Number of Alive Nodes vs. Round.....	37
Figure 7	The Dead Nodes vs. Round	38
Figure 8	Number of Packets Received at Base Station vs. Round	39
Figure 9	Total Dissipated Energy vs. Round.....	40

LIST OF TABLES

TABLES

Table 1	Parameter that Used in the Thesis	36
----------------	---	----

LIST OF ABBREVIATIONS

BS	Base Station
CH	Cluster Head node
DSR	Dynamic Source Routing
DWEHC	Distributed Weight-Based Energy-Efficient Hierarchical Clustering
EEHC	Energy Efficient Hierarchical Clustering
GA	Genetic Algorithm
GEAR	Geographical and Energy Aware Routing
GPS	Global Positioning System
HEED	Hybrid Energy Efficient Distributed Protocol
ILP	Integer Linear Program
LEACH	Low Energy Adaptive Clustering Hierarchy
MILP	Mixed Integer Linear Program
MINLP	Mixed Integer Non Linear Program
MN	Member Node
MANET	Mobile Ad-Hoc Network
PC	Personal Computer
RN	Relay Node
SN	Sensor Node
WINS	Wireless Integrated Network Sensors
WPAN	Wireless Personal Area Network
WSN	Wireless Sensor Network

CHAPTER 1

INTRODUCTION

1.1 Introduction

Many systems of scientific interest can be represented as networks, sets of nodes or vertices joined in pairs by lines or edges such as internet, world wide web, food webs, neural networks, metabolic networks. The study of networked systems has a history stretching back several centuries, but it has experienced a particular surge of interest in the last decade, especially in the mathematical sciences [1] and recently wireless sensor networks also have become an important area in research and science.

In wireless sensor networks, such as setting up processing or communication networks with different characteristics is including smart sensors. For this reason sensors are generally equipped with data processing and communication capabilities. Sensing circuit measures the parameter setting and the electric signals are used to convert these measures. Each sensor interested parties [2, 3] has an onboard radio was used to send the data collected. There are different applications for wireless sensor networks based on the capabilities of these sensors. This wireless sensor networks monitoring is used mainly to establish data collection and communication. The difference between these applications, sensors may require different characteristics on different networks.

In monitoring case, sensor nodes often need to collect and send data to some predefined parameters. Since a manager needs to communicate with each other or these sensors communication and data collection capabilities must. A habitat monitoring application, for example, the user must follow certain parameters such as temperature and humidity. This network probably will become a bottleneck for data

collection applications will include a large number of sensors since. There are different approaches to data collection is mainly based on data collection issues.

Network of sensors used to gather meteorological variables such as pressure at the same time. These measurements are then used in preparing the estimates or natural phenomena hard to detect. In situations such as earthquake disaster management, sensor networks that directs emergency response units it can also be used to match the rest of selective survival of the affected area. Military surveillance tasks available in sensor networks and moving targets, chemical gases, or micro-substances [4] can be used to detect the presence.

In order to design good protocols for wireless microsensor networks, it is important to understand the parameters that are relevant to the sensor applications. Sensor networks may contain hundreds or thousands of nodes, and they may need to be deployed in remote or dangerous environments. In order for the efficiency of application deployment should be easier. These networks should function as long as they can and the sensors are usually not able to recharge batteries. Therefore hardware and software structures should be deployed with energy consideration [5].

Networks of wireless sensors may have different characteristics according to the application as given above. Most of the network between sensor nodes and sensors based applications often requires communication in order to communicate with a radio transmitter. Moreover, any communication between nodes is very limited so single network node energy requires energy consumption.

Has lately different algorithms based on different approaches to the optimization of energy consumption in wireless sensor networks, energy consumption has become a hot research field.

In addition to the problem of energy consumption one major problem of wireless sensor networks is the difficulty of monitoring these networks. There are different researches in literature for the monitoring of sensor networks. The structure of these protocols differs with their different aims; discover failed nodes [6, 7], compute the coverage [8, 9], determine the remaining energy level [10] or topological mapping of the network [11]. Zhao et al. in [12] provides a monitoring tool which continuously aggregates and computes different properties of the networks such as loss rates, energy levels or packet loss.

In recent years, Ad Hoc wireless networks due to multiple potential applications, has attracted a lot of attention, both civilian and military. Several approaches networks [13], for such studies it has been published in the literature.

Some of these studies are based on clustering schemes for wireless networks and recently there have been many applications on this area.

1.2 Wireless Network Clustering

In the continuing furry of research activity within physics and mathematics on the properties of networks, a particular recent focus has been the analysis of communities within networks. Detection of these communities has become a new interest in research areas and there are different methods based on different theories such as graph theory. Many of these scientific studies have shown that community detection in wireless networks gives rise to different applications. Wireless network clustering is one of the most used techniques in wireless sensor networks in order to prolong network lifetime and increase the efficiency of data gathering. Since these networks usually have large scale of nodes the communication based on clustering namely hierarchical routing results an effective communication scheme.

In a clustered network there are usually two kinds of nodes such as cluster heads and cluster members. Once the clusters and cluster heads are determined hierarchical routing can take place. In this routing scheme cluster members only need to communicate with their cluster heads, in some applications they also may need to communicate with the members within same cluster. On the other hand cluster heads need to be in communication both with other cluster heads and the members of their own cluster. In case of any communication, cluster members just need to send their data to the cluster head, they do not need to know whole topology and this provides data aggregation and decrease in energy consumption. Cluster heads will need to do all other things left such as finding destination address, computing the shortest path and sending the message via the shortest path. In order to design a more efficient network and prolong the networks life time the selection of cluster heads becomes very important.

Clustering has so many advantages in wireless sensor networks such as network scalability. It can also localize the route set up within the cluster and thus reduce the size of the routing table stored at the individual node [14]. Moreover clustering can conserve communication bandwidth since it limits the scope of inter-cluster interactions to CHs and avoids redundant exchange of messages among sensor nodes [15]. Furthermore, a CH can aggregate the data collected by the sensors in its cluster and thus decrease the number of relayed packets [16]. Clustering also enables bandwidth reuse and can, thus, increase system capacity. Using clustering enables better resource allocation and helps improve power control [17].

Yang Qin and Jun He re-phrase [18] in 2004 about the hierarchical routing in Ad Hoc wireless networks.

Raj et al. in [19] have proposed a different kind of clustering structure which aims to organize whole network into smaller clusters a sub clusters. In case of this clustering structure sensor nodes deployed in the wide area, will form many cluster groups for efficient network organization, where each cluster group contains sensor nodes in majority, one cluster head and one node leader. The main role of node leader is to gather and aggregate the sensor data from other sensor nodes in the same cluster group. The cluster head will then forward the aggregated data coming from the node leader, to the base station either directly or through other cluster heads. The authors also provide a fault tolerant clustering algorithm with this structure.

Recently there are many different approaches for clustering and cluster head selection. Different algorithms give rise to different improvements. Since wireless sensor networks become more and more important everyday clustering techniques seem to be improved in next years.

1.3 Wireless Sensor Network Clustering Applications

Various approaches have appeared in the literature for the study of Ad Hoc networks[13]. Some of these studies are based on clustering schemes for wireless networks and recently there have been many applications on this area.

In 2001, Beongku and Papavassiliou studied on architecture for supporting geo multicast services in mobile ad hoc wireless networks [20]. For the implementation

first wireless network clustering is made and a head cluster is chosen for each group, their network structure consists of elements similar to cellular networks. For example cluster heads act as base station in a cellular network and mobile nodes are similar to mobile station. Another paper based on wireless network clustering is published by Taghi et al. in 2005 about the intrusion detection in wireless networks using clustering techniques with expert analysis [21].

In 2008, Z. Wang et al. have published a paper about a position based clustering technique for ad hoc inter vehicle communication [22]. In an inter vehicle system two passing vehicles can exchange data or vehicles can act as routers and transmit the data to another vehicle. With this principle, highly efficient accident warning systems are possible; cars involved in an accident can send warning messages back over a predefined number of other vehicles, thus avoiding motorway pileups and enhancing the traffic safety. The importance of inter vehicle communication for emergency is also described in [23] as in case of emergency situations, it is paramount to be able to forward important information as soon as possible. Such emergency information could be originated by first responders or locally by cars on highway and could be directed to the whole network (broadcast) to part of the network (broadcast to specific highways) or to special centers such as police, emergency rooms, hospitals, etc.

Monitoring of wireless sensor networks is one of the major problems that are given in the previous section. Han et al. in [24] provides a hierarchical monitoring application based on the clustering. The application is mainly provided to collect the residual energy information of the sensors continuously to construct an energy map at the base station. However due to the large numbers of sensors this data collection requires high energy consumption and in order to provide an energy efficient algorithm clustering techniques are used in this work. At the beginning whole network is separated into clusters and for each cluster some nodes called cluster heads are determined to act as aggregator in data collection process. Also, a tree topology, the central node and a bridge is formed between two adjacent sets and the distribution nodes made therefrom. Based on energy data collected, a set of polygonal lines representing different energy levels is produced independently for

each cluster. Topology tree is then used to collect energy graphics leaf nodes to the base station.

Therefore the cost for message transmission is reduced by using clustering and in network aggregation [24].

1.4 Outline of the Thesis

This thesis proposes a method for saving energy in WSN that each sensor has different energy. There are 3 types of sensors; the means of type is 3 energy types. Also for cluster head election it can be used this different energy for cluster head election. This thesis addresses the problem of energy consumption in wireless sensor networks with network clustering techniques. Rest of the thesis is organized as follows;

Some network clustering techniques are briefly explained in Chapter 2. Chapter 3 includes the details of hierarchical routing type. The details of the new clustering algorithm and simulation results are given in Chapter 4. Comparison has been done between new clustering algorithms in the same chapter and final decision for clustering algorithm is also given in Chapter 4. In this chapter a deep analyze has been done on new algorithms and the applicability of algorithms in real networks. And finally Chapter 5 concludes the thesis.

CHAPTER 2

LITTERATURE SURVEY

2.1 Introduction

In this chapter briefly overview the works on the main WSN design issues is presented: coverage, scheduling, routing and sink location problems. At first survey the ones dealing with only one of them. Then, its presented integration attempts in order to place of contributions. WSN related research is immense. That should frankly confess that concentration is mainly on the ones with a mathematical programming and optimization approach.

2.2 Sensor Placement

The first proposed procedure attempts to maximize the average coverage of the grid points. The second proposed procedure attempts to maximize the coverage of the grid point that is covered least effectively. A theorem proved in the paper provides a sufficient condition under which the non-grid points are adequately covered by the proposed algorithms. The major drawback of the paper is that although the proposed methods provide coverage for the sensor field, they completely ignore energy consumption and network lifetime issues.

In Chakrabarty et al. [9] an integer linear program (ILP) that determines the optimum sensor locations is proposed. The objective is the minimization of the total sensor deployment cost. The constraint is the coverage of the grid points with the required quality. As in Dhillon and Chakrabarty [8] the energy consumption in sensing and processing, in routing the data packets are ignored in the paper. Moreover, an effective solution method for large instances of the ILP is not provided.

In Yang et al [10] the sensor network is modelled as a graph with the set of vertices being the set of sensors. An edge exists between two nodes if the two corresponding sensors are within the each other's communication range. An ILP that determines elements of a subset of the vertices is proposed. The objective is the minimization of the number of elements in the subset subject to coverage requirement constraints. A solution procedure based on constructing a feasible solution from the linear programming (LP) relaxation solution of the ILP is also proposed. Although the proposed method finds a set of sensors that cover the sensor field with the required quality, it does not explicitly determine the activity schedules of the sensors, sensor-to-sink data flow routes in order to maximize the network lifetime.

In Altinel et al. [11] the problem of determining sensor locations such that the sensor field is covered with the required quality is addressed. The ILP proposed for this problem aims to minimize total deployment cost. In addition to the classical coverage constraint, the placement of at most one sensor at any point of the sensor field is allowed. They, however, disregard this restriction in their succeeding work (Altinel et al. [12]) where they consider minimum cost coverage problem for heterogeneous WSN, with differentiated coverage quality constraints. In both works they explain how the same ILP models can be used to deal with imperfect and probabilistic sensing in addition to perfect sensing. Greedy and Lagrangean heuristics are proposed in order to solve large instances efficiently. The major drawback of these papers is that they ignore the issues of energy consumption and network lifetime. Wang and Zhong [13] also consider the problem described in the first work of Altinel et al. [11]. Although they develop the same ILP formulation their solution approach is different. They construct a feasible solution for the ILP using an optimal solution of its LP relaxation.

Ganesan et al. [14] formulate an optimization problem that considers jointly sensor placement, transmission structure and data structure in a data gathering sensor network, in terms of an energy related cost function.

They show that significant power gains can be obtained with such a node placement scheme over commonly used uniform random placements. Although they rigorously consider the sensor placement problem, the authors ignore sensor activity scheduling issue.

2.3 Sensor Activity Scheduling

In Nakamura et al. [16] the problem of determining activity schedules of the sensors is addressed. A MILP with the objective of minimizing the total energy consumption is formulated. Constraints of the MILP ensure coverage of the sensor field with the required quality and connectivity of the network in each time period. The MILP optimally determines which sensor is active in which period. In the experimental study section it is shown that the network lifetime value obtained using the MILP is much higher than that obtained without performing any sensor activity scheduling. One drawback of the proposed model is that it does not explicitly consider the routing energy. Sensor placement issue is also disregarded.

In Cardei et al. [17] the problem of covering a set of targets with a set of sensors is considered. Only subsets of the sensors that can cover all of the targets are active at any given time, others are in sleep mode. A mixed integer nonlinear program (MINLP) is proposed to maximize the coverage lifetime by determining the sensor subsets and their active time. The constraints guarantee that the active time of a sensor is not greater than an upper bound and every target is covered by the active subset. The major drawback of the paper is that it does not explicitly consider the energy consumed in routing the data packets. Moreover, there is no lower bound on the active time of a sensor subset. One other drawback is that the issue of sensor placement is ignored in the paper. Nanez et al. [18] work on the same problem. They develop a distributed algorithm to obtain suboptimal solutions in an online fashion or large-scale settings. They use game theory in developing the algorithm. The same problem is also considered by Alfieri et al. [19]. Their mathematical model takes explicitly into account the energy consumption in data routing. They use a column generation algorithm to find active subsets and their active periods.

In Ha et al. [20] sensor network is modelled as an undirected connected graph. At any given time only one of the connected subgraphs rooted at the sink is active, others are in sleep mode in order to save energy. An ILP that determines the connected subgraphs is proposed. The objective of this ILP is the minimization of the shared sensors. The constraints guarantee that each sensor belongs to at least one subgraph, the subgraph is connected and rooted at the sink. Also for each sensor, the

number of neighbors belonging to the same subgraph has a limit so that the sensor is close to the active subgraph when the subgraph it belongs to is in sleep mode. One drawback of the proposed ILP is that it does not consider coverage of the sensor field. Moreover the energy spent on sensing, processing and routing is not taken into account.

In Liu et al. [21] each sensor can watch at most one target at any given time, and each target should be watched by a predetermined number of sensors. The problem is to find a schedule that meets these requirements. The objective is to maximize lifetime of surveillance subject to energy restrictions. A polynomial time algorithm that finds an optimal solution of the described problem is proposed. The major drawback of the paper is that it ignores the energy consumption in data routing. Moreover the assumption that each sensor can watch at most one target at any given time is restrictive. The same problem is also considered in Zhao and Gurusamy [22]. They take into account the energy consumption in data routing and find sensor-to-sink data flow paths.

Moreover, in the literatures that be shown most of them is worked about the clustering method that sensor is selected as probability value for be cluster head. Also in the most of the literatures the probability value for selecting of cluster head is same.

2.4 Data Routing

In Sankar and Liu [27] a LP formulation is presented. The objective is the maximization of the network lifetime. The first constraint is the flow balance equation. The number of packets received by a sensor should be equal to the number of packets transmitted to other sensors. The second constraint is the energy limitation. The energy spent in transmitting the data packets should be less than the battery energy. A distributed routing algorithm that reaches an optimal solution to within an asymptotically small relative error is proposed. The major drawback of this work is that it ignores sensor placement and sensor activity scheduling issues. Also energy spent in receiving the data packets is not taken into account.

In Hua and Yum [30] the problem of routing the data to the sink node in a way to maximize network lifetime is considered. Network lifetime is defined as the shortest lifetime of all the nodes. A node can only use its downstream neighbors (downstream with respect to the sink) to route its traffic. The flow coming from an upstream node j is reduced at node i because some of the information coming from node j is the same as those coming from other neighbors of i . The problem is first formulated as a mathematical program where the objective is the minimization of maximum normalized nodal power consumption for the bottleneck nodes. Normalization is done by nodal battery energy. The constraints are linear flow conservation constraints. This min-max objective function is not differentiable. Hence a smoothing function is used. The smoothed objective function is approximately equivalent to the original objective function. The Karush-Kuhn-Tucker conditions are not sufficient for optimality for this reason a set of sufficient conditions and a gradient descent algorithm for a distributed application are developed. At each iteration of the algorithm each node adjusts its downstream flow in the direction of the gradient until each flow link satisfies the sufficient optimality conditions. According to the simulation results it is possible to say that the algorithm converges efficiently.

In Pham et al. [32] sensor network is divided into a grid structure. It is assumed that each grid cell can be covered by any sensor in the cell. It is also assumed that a sensor in a cell can transmit data packets to any sensor in the adjacent cell. After these simplifying assumptions the problem is to find the total data flow among the cells to maximize the lifetime until the first cell loses area coverage. A LP with the objective of network lifetime maximization is proposed. The constraints are flow balance and battery energy limitation. These constraints are written for the cell not for each sensor. Simulations show that the proposed method increases network lifetime.

In Ciciriello et al. [33] the problem of routing data efficiently from multiple sources to multiple sinks is presented. An ILP which minimizes the number of links used in transmitting data from the sources to the sinks is proposed. The constraints guarantee a connected, end-to-end path for each source-sink pair. A novel decentralized scheme that adapts the topology by maximizing the overlapping among source-sink paths,

therefore minimizing the overall number of network links exploited is proposed. The major drawback of the paper is that it does not explicitly consider the energy consumption in sensing and processing the data and in routing the data packets.

In this thesis it be used the different energy for each sensor and this energy selection is randomly. Then the selection of cluster head is depended on energy also the probability value for cluster head is not same.

2.5 Sink Location

Vincze et al. [36] the sensor data a mathematical model that determines the average distance at least close to the sink sinks location. Repeated able to find places to sink an algorithm provided by the mathematical model is presented. However, it is not practical for wide area sensor network algorithm uses general information about the network. Thus, position information of the neighboring nodes based only on a new sink should repeat an algorithm that performs the distribution has been proposed. These two algorithms are compared and it is shown that the performance of the second one is very close to the performance of the first one. It is also argued that the neighboring nodes of the sinks have a high traffic load, thus the lifetime of the network can be elongated by relocating the sinks from time to time.

Consequently a relocation algorithm for the coordinated relocation of multiple sinks is proposed. The simulation results show that the algorithm extend the network lifetime significantly. One drawback of the paper is that although sinks are optimally located, the energy spent in sensing and processing and in routing the data packets are not explicitly considered.

In Basagni et al. [37] a mobile sink is considered. The problem is to determine the starting site and the route for the mobile sink together with the sojourn times of the sink at each visited site so that the network lifetime is maximized. First a MILP formulation is proposed. The objective is the maximization of the sink's total time at sojourning sites. The first constraint guarantees that the total energy spent in receiving and transmitting packets and in setting up/releasing routes when the sink moves to a site for each sensor is less than the battery energy. The remaining constraints ensure the formation of a path for the sink and eliminate cycles that can

be obtained. In the second part of the paper the first heuristics for controlled sink movements that are fully distributed and localized are described. Simulations show that the heuristics increase the network lifetime considerably. One drawback of the paper is that it does not explicitly include the energy consumption in sensing and processing and in routing the data packets in the MILP formulation. Besides the sink can do only one hour during the network lifetime, which is fairly unrealistic.

2.6 Works That Integrate Some of the Design Issues

The second MILP model proposed by Patel et al. [38] integrates placement, data routing and sink location issues. The objective is the minimization of the total cost of placing the sensors and the sinks. The constraints guarantee the coverage of the sensor field with the required quality and flow conservation. The MILP finds optimally sensor and sink locations and sensor-to-sink data flow quantities. They also develop another MILP model with network lifetime maximization objective. In this MILP in addition to the coverage and flow balance constraints there is the energy constraint that limits the energy spent in data routing.

In Hou et al. [39] placement and data routing issues are integrated. The problem is to find the locations of a given number of relay sensors, to allocate a given amount of energy to them and to determine sensor-to-sink flow quantities. A mixed-integer nonlinear program (MINLP) with the objective of network lifetime maximization is proposed. The constraints ensure flow balance and the energy limitation in receiving and transmitting the data packets. Solving the MINLP is computationally difficult.

Therefore, a heuristic algorithm is developed. Through numerical results it is shown that the heuristic algorithm offers a very attractive solution and some important insights to the problem addressed.

Kim et al. [42] integrate data routing and sink location. They consider a static sink. They formulate a MILP where the objective maximizes the minimum amount of data produced by each sensor and the total data packets generated. The MILP optimally determines the locations of a predetermined number of sinks, the sensor-to-sink flow routes and the data volume produced by each sensor. The constraints are flow

balance and battery energy limitation restrictions. Unfortunately an efficient solution procedure for the MILP is not presented.

2.7 Low-Energy Adaptive Clustering Hierarchy (LEACH)

The LEACH protocol was developed within the μ AMPS project at MIT. In the LEACH (Low-Energy Adaptive Clustering Hierarchy) [5], [28], [29] algorithm, the sensors organize themselves into local clusters, with one sensor acting as the local base station or cluster-head. LEACH uses a hierarchical network structure and is a source initiated protocol with proactive routing. Clusters are being re-created every round, and each node decides whether to become a cluster-head for the current round. The node picks a random number; if it is smaller than a threshold $T(n)$, the node becomes a cluster-head for that round. $T(n)$ is the threshold value for each node n .

$$T_n = \frac{p}{1 - p(r \bmod 1/p)} \quad (2.1)$$

If the node has not been a cluster head in the last $1/p$ rounds (2.1) LEACH reduces the communication energy by as much as 8 times compared with direct transmission and minimum transmission energy routing. The problem with LEACH is that it requires direct communication to the sink node; LEACH is not designed for networks where the sink node is to be located outside the communication range of sensor nodes. Another problem is dynamic clustering overheads as head changes and advertisements may consume the energy that is gained from communication.

After they selected using cluster head node algorithm, cluster head node for all other nodes on the network must also notify chose this role for the current tour. To do this, each cluster head node broadcasts an advertising message. Each node of the cluster, which then decided it must notify the head node cluster, will be a member of the cluster. Each node back to participate in the selected cluster head transmits the request message. This message ID and cluster head node IDs [28] formed is still a short message.

In case of any communication between two nodes, the transmitter node just needs to send the message to its cluster head and the remaining parts will be completed by the

cluster head. Once the cluster head receives the message it will send the message to receivers cluster head and this node will send the message to the final receiver node. Therefore an effective way of energy consumption is provided and moreover since all of the nodes does not need to know whole topology this communication structure will decrease the complexity.

On the other hand in case of direct communication every node needs to send their messages directly to the BS or another receiver. If the receiver is far away from the node then transmission will require higher amount of energy therefore the transmitter and receiver nodes both will lose a large amount of their energy. This will cause nodes to quickly drain their batteries and reduce the networks lifetime. However this type of communication may also be acceptable if the nodes are located close to each other or BS.

According to the authors in [28] LEACH can achieve over a factor of 7 reduction in energy dissipation compared to direct communication. Although LEACH provides adaptive energy consumption and it increases the efficiency of wireless sensor networks there are still some problems with energy consumption and data aggregation.

Since every node can become a cluster head in LEACH algorithm it sometimes may result with undesired topologies. In some cases border nodes can become cluster head and in this case the higher distance between cluster heads and cluster heads members increases energy consumption and results an inefficient network. On the other hand distance between the cluster heads also becomes important for efficiency; one of the undesired states in clustering topology is the small distance between cluster heads. In order for efficiency to be higher, distance between the cluster heads should be adequate enough for occurrence of two different clusters.

LEACH formulation as below;

$$T_n = \frac{p}{1 - p \left(r \bmod \frac{1}{p} \right)} \frac{E_{ncur}}{E_{nmax}} \quad (2.2)$$

E_{ncur} Is the current energy of the node and E_{nmax} is the initial energy of that node. Therefore they represent the energy level with the coefficient E_{ncur} / E_{nmax} .

This approach leads higher energy level nodes to become cluster heads and simulation results show that improvement in efficiency can be provided. However there are still some disadvantages also in this case, after certain number of rounds network becomes stuck. Since after some certain rounds most of the nodes will have low level of energy, the threshold for becoming a cluster head will become too low. Although there will be still some nodes which have enough energy to send data due to the low energy level of threshold the network will already become stuck [30]. The equation is modified as in 2.3 with a coefficient for the nodes that has not become a cluster head in $1/p$ rounds.

$$T_{n_{new}} = T_{n_{LEACH}} \left(\frac{E_{n_{cur}}}{E_{n_{max}}} + r_s p - \frac{r_s p E_{n_{cur}}}{E_{n_{max}}} \right) \quad (2.3)$$

In equation 2.3 r_s is the number of rounds for a node that had not become a cluster head, if this number reaches $1/p$ then the formula will be modified the older version as in LEACH then $T_{n_{new}} = T_{n_{LEACH}}$. Therefore remaining nodes will have chance to become cluster head and in other cases r_s will be set to 0 in order to achieve modified formula.

By this modification authors has solved the problem of stuck network and also they have reached more effective energy consumption than LEACH. With these modifications a 30 percent of increase in lifetime of micro sensor networks can be accomplished.

Handy et al. in [30] leaches cluster head selection algorithm has discussed two amendments. Cluster nodes to identify themselves they get into their heads. Or said base station having a communication node which is not necessary. After clusters and cluster heads notification messages identified cluster nodes head set according to signal strength, select a predefined set. At the end of the tour, is not all clusters; However, the size of each cluster head-sets [31] are protected to an equal number of bullets. Whose head do not set the size of the cluster nodes to participate in the next elections is one big reason, but the size of the nodes of the cluster head set to 1 may be candidates for the next round. This reduces the number of cluster structure of elections and provides more efficient clustering.

2.8 Hybrid Energy Efficient Distributed (HEED)

Younis et al. in [32] has approached a new clustering algorithm based on some probabilistic equations. In this algorithm it is assumed that nodes have no specialties such as having a GPS. The main approach is to cluster all the nodes in an equal way which is based on probability. As the other clustering techniques HEED algorithm also aims to prolong the network lifetime and increase the efficiency. In order to compare network time they defined a certain value as the first or last node depletes its energy. The main factor in the probabilistic approach is the residual energy of nodes.

In HEED algorithm every node is exactly mapped to one cluster and this node has to be able to communicate with the cluster head via single hop. The transmission ranges and energy levels are classified and defined as inter-cluster transmission range, inter-cluster power, intra-cluster transmission range and intra cluster power. Inter cluster transmission range is higher and inter transmission requires more energy than intra cluster transmission as expected.

Cluster head selection is mainly based on two different approaches that are about energy level and cost. In order to consider the energy levels of nodes for cluster head selection authors define an initial set including high energy level nodes. Therefore it is prevented for low energy nodes to become cluster head. The second parameter cost is used to break ties between nodes. If two different nodes in the same intra cluster transmission range sends their willingness to become a cluster head a tie occurs between these two nodes.

The HEED algorithm is mainly based on probability of being a cluster head which is given with the following equation 2.4, all the nodes set their initial probability to become a cluster head as C_{hprob} ;

$$C_{hprob} = \frac{C_{prob} E_{res}}{E_{max}} \quad (2.4)$$

C_{hprob} is the probability of a single node to become a cluster head, C_{prob} is the small constant that is defined by algorithm.

HEED provides an efficient clustering algorithm based on probabilistic to increase the network lifetime. There are some different approaches on HEED to increase

efficiency. O. Younis et al has provided an improved algorithm IHEED which is mainly based on HEED. This algorithm integrates node clustering and multi hop routing in order to increase efficiency of network.

One of the most important challenges in IHEED is integration of clusters in data aggregation trees without degrading path quality [33]. In this topology only cluster heads are used to construct the aggregation tree, since cluster heads will be distributed well even if the nodes are not well distributed path quality will be higher inter cluster level.

2.9 Energy Efficient Hierarchical Clustering (EEHC)

EEHC [34] algorithm is also distributed, randomized clustering algorithm for WSNs as previous LEACH algorithm. EEHC has two stages. In the initial phase of the algorithm, each node volunteers to become CH with probability p to the neighboring nodes within its communication range. Volunteer CHs announcements of the node are forwarded at the range of k -hops away. After the nodes that are not volunteers receive announcements, they decide to become a member of closest CH.

If a node does not receive any announcement it becomes forced CH. All these CHs are first level CHs of the network and they select second level heads in order to obtain multi-tier clustering topology. This algorithm provides k -hops intra-cluster topology and h -hops connectivity between CHs to sink. Data sensed by nodes are transmitted to from lower layer CHs to upper layer CHs in order. In every layer data aggregation is executed in this method. This algorithm has time complexity of $O(n)$.

2.10 Distributed Weight-Based Energy-Efficient Hierarchical Clustering (DWEHC)

DWEHC algorithm [35] HEED algorithm to achieve a more balanced cluster and to optimize intra-cluster topology is recommended. WSN each node computes a weight value;

$$W_{weight}(s) = \left(\sum_{u \in Na,c(s)} \frac{(R-d)}{6R} \right) \times \frac{E_{residual}(s)}{E_{initial}(s)} \quad (2.5)$$

Where R is the cluster range and d is the distance from node s to neighboring node, $E_{residual}$ is the residual energy in node s , and $E_{initial}$ is the initial energy in nodes which is identical for all nodes. The weight is a function of the sensor's energy level and the proximity to the neighbors. Nodes decide to be cluster head if their weight is the largest among the nodes in the communication range. Nodes that have direct link to CH called as first-level member. These first level members are benefited by CH as relay node of multi-level members if multi-hop transmission to CH is more energy efficient than direct transmission. Sensor nodes have to know their own position information in order to calculate transmission costs according to distance. DWEHC generates well-balanced clusters than HEED and also achieves lower energy consumption than HEED.

CHAPTER 3

WIRELESS SENSOR NETWORKS ROUTING ALGORITHMS

3.1 Research Groups and Projects for Wireless Sensor Networks

As wireless sensor networks will have a wide application area in the future, they have gained substantial research interest. There are many groups working on the area of Wireless Sensor Networks. Some of them are as follows. IEEE 802.15 Working Group for Wireless Personal Area Network (WPAN) [13] is defining Physical and MAC layer [14] industrial standards. Wireless Integrated Network Sensors (WINS) [15] of UCLA Electrical Engineering Department, has developed LWIM (Low Power Wireless Integrated Micro sensors) and WINS communication protocol working in collaboration with the Rockwell Science Center. MIT μ AMPS (Micro Adaptive Multi-domain Power-aware Sensors) Project [16] has developed the μ AMPS hardware and LEACH algorithm.

Berkeley WEBS: Wireless Embedded Systems Group [17] has worked on the Smart-Dust and Pico-Radio Projects. It is also working on other projects like TinyOS: Operating System support for tiny-networked sensors, and FPS: a network protocol for radio power scheduling in Wireless Sensor Networks.

3.2 Classification of Wireless Sensor Networks Routing Algorithms

Many surveys have been conducted for Wireless Sensor Networks and their routing schemas: Karaki et al. [3], Akyildiz et al. [18], Akyildiz et al. [19], Demirkol et al. [20], Akkaya et al. [21], Rentala et al. [22], Xu [23], Royer et al. [24], Sahni et al. [25]. They generally classify the routing protocols according to network structure as flat network routing, hierarchical network routing and location-based routing. Classification can be made according to their protocol operation as negotiation-based

routing, multipath-based routing, query-based routing, and QoS-based routing. The initiator of communications as the source or destination can also be used to categorize them. Path establishment can be made proactive, reactive or a hybrid of both. Generally, Static Routing schemes tend to try to minimize the energy used in the routing process. Drawback is generally these schemes heavily load a few of the sensors and after burning all of the energy of these few sensors, these schemes are open to the creation disconnected networks. The first sensor death in these schemes happens very early. To overcome this problem and to increase the network lifetime, dynamic routing protocols are developed. They do not use the same routing path for a long time: instead they alternate the routing paths according to the energy remaining in the sensors, and form clusters and other methods to increase the network lifetime. In the next sections, it can be summarize some of the important routing algorithms from the literature.

3.3 Routing Algorithms in the Literature

3.3.1 Sensor Protocols for Information via Negotiation

A group of adaptive protocols called SPIN [26] was designed to solve the problems of the classical protocols. Flooding and gossiping are classical routing protocols that were first applied to Sensor Networks, but they had disadvantages in this domain. Applying flooding to Sensor Networks causes implosion, which is duplicate messages arriving to the same node; overlap, when two nodes that are in the same region send similar messages to the same neighbor and resource blindness, that is nodes not taking energy constraints into consideration.

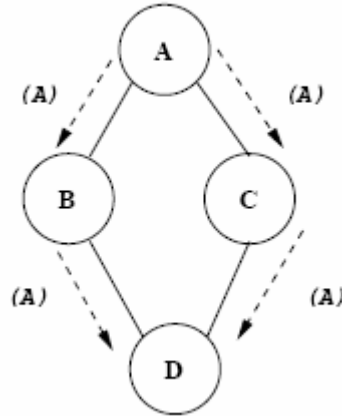

Figure 1 Implosion Problem: A's information is sent to D from both B and C [26]

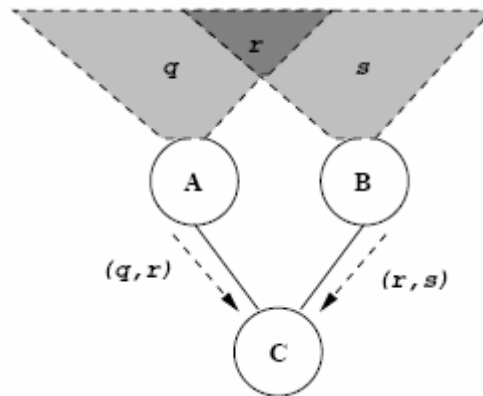

Figure 2 Overlap Problem: C receives information of region r from both A and B [26]

For solving implosion, gossiping randomly selects one or a sub-set of neighbors and then sends the message only to those neighbors, but this brings a propagation delay. SPIN solves these problems by using negotiation and resource adaptation. SPIN has a flat network structure and reactive routing and is a source-initiated protocol. Whenever a sensor has data, it sends its neighbors a description of the data (meta-data) with an advertisement packet (ADV), the interested neighbors answer the advertisement with a request packet (REQ), and the sensor sends the entire data packet (DATA) only to the interested neighbors. The importance of SPIN is that it is one of the first algorithms that introduce local messaging: sensors keep routing information only about their direct neighbors, which brings scalability. SPIN-2 is the resource aware version that refrains from going into excessive communication when

the battery level becomes low. The problem with SPIN protocols is: even if some sensors (sinks) are interested in the data, if the sensors between the source and the sink are not interested in the data, the data cannot reach the destination.

3.3.2 Directed Diffusion

Directed diffusion [27] is an important milestone in data-centric wireless networks, and many algorithms are developed based on it. Directed diffusion has a flat network structure. It is a destination-initiated protocol that uses reactive routing. The protocol uses data-centric routing, where queries are answered by a sub-set of all sensors that have a certain kind of information and not the whole network. This special information query can be a question like, "What is the temperature at region r ?" or, "Which are the areas that have a temperature over 10°C ?" Directed diffusion consists of three stages: interest propagation, gradient setup and data delivery.

In "interest propagation", the sink node floods an interest for a kind of data through the network. The reason for using interest requests is to eliminate the possibility of receiving undesired or irrelevant data. The initial interest also specifies the initial frequency data flow from sensors to the sink, which could be every minute, and includes a timestamp for the nodes to stop sending data, for example after ten minutes. Nodes add the interests they receive to their interest cache. These interest entries contain the ID of each neighbor from whom the interest was received and the data rate towards that neighbor.

Directed diffusion, "gradient setup", mentioned often neighbors nodes send all the data with information relative to the initial meeting of the second phase of interest. Sending data, the frequency gradient: the frequency in which to send data about a particular area of interest to particular neighbor (data rate) d . Directed diffusion also uses data collection. To add data to sink nodes receive data to their own data caching. They give you receive a data message is check to see if the new data cache nodes. If there is already data cache, the data already transmitted and means ignore the message. When data arrives toilet, washbasin reinforces way by sending one or more other interests. This interest, the same data is sent to a specific source node along a single path, sending ask a higher data frequencies and has a longer timeout value.

This enhanced response can only interest the way the first node sending data received by each hop.

3.3.3 Rumor Routing

Rumor routing [29] is an improvement of directed diffusion algorithm. It uses a flat network structure. It is also a destination-initiated protocol using hybrid routing. Rumor routing floods the events but not the interest; if the number of events is small and the number of queries is large flooding the events creates an advantage. To flood an event, rumor routing creates packets that are called agents which have a certain time to live (TTL). When a node senses an event, it adds the event to its event table and floods an agent with a certain TTL. The agent contains a table of events observed by the node. As the agent is flooded through the network, the nodes update their event tables after receiving the agent. If an agent observes another event, it also updates its event table and propagates the new event along with the original event. An agent keeps a list of all nodes it has visited and as the next hop, chooses a neighbor that is not in the list. When an agent arrives at a new node, it decrements its TTL before it hops to another node. The agent is discarded and not sent further when its TTL is zero. When the sink sends an interest, the interest travels randomly until it finds a node with a path to the relevant event. The protocol works efficiently on networks with few events and many interests, but does not provide energy efficiency in other kinds of networks. With the events table and the list of visited nodes, agent packet size can grow very large in networks with frequent events. Agents contain one route to each event, and if there are many interests for these events, the nodes over that route can finish their batteries quickly. Agent's choices for selecting their next hop affect the network lifetime because the queries are routed through that path.

3.3.4 Altruistic Energy Aware Routing Protocol

This protocol is an improvement to the EAR protocol; it uses the notion of altruistic nodes that are willing to forward traffic in the name of their neighbors [36]. It is as well developed in the “Pico Radio” project of Berkley University. Like EAR,

EAR+A uses a flat network structure and is a source-initiated protocol with proactive routing. The Altruistic nodes can be nodes with access to a power-line or a node's probability to become altruistic. Which is the energy, the number of altruists in their neighborhood, or a node, an altruist last time you have to decide on a data package received and a subsequent data transmitter, etc. Since the time may depend, first looks all possible neighboring j nodes and their costs up c_j interest from the cache. J altruists who are currently above the cost of the c_j nodes (according to the altruist cache) are reduced by a fixed factor of $0 \leq \alpha \leq 1$ (called the cost reduction factor).

In the simulations, the network lifetime is taken as the time that 50 per cent out of the total number of nodes die due to energy depletion. EAR + A gives you an advantage over the average earnings scheme EUR unrestricted nodes and reach 8.5 percent percentage increases to 70 percent. However, the altruistic scheme is not always better; Since unrestricted nodes with fixed rates are some random seed EAR that a better network lifetime. In addition, it should be noted that these results are taken in relation to the existence of altruistic nodes with access to a continuous power supply like a power line.

3.3.5 Geographical and Energy Aware Routing (GEAR)

Some applications may require requesting information from some of the regions of the monitored area. The GEAR (Geographical and Energy Aware Routing) [51] algorithm has been developed to meet this requirement. GEAR uses location-based routing as the network structure. The process of forwarding a packet to all of the sensors in the target region consists of two phases:

The region is divided into four sub-regions and four copies of the packet are sent to these regions. This splitting and forwarding process continues until regions with only one node are left. However, under some low-density conditions, recursive geographic forwarding sometimes does not terminate, routing uselessly around an empty target region before the packet's hop-count exceeds a limit. In these cases, GEAR uses restricted flooding. GEAR's performance metrics are the number of data packets sent and successfully delivered before network partition and fraction of pairs still connected after partition. It is shown that for non-uniform traffic, GEAR delivers 70

per cent to 80 per cent more packets than its competitor GPSR. For uniform traffic, GEAR delivers between 25 per cent and 35 per cent more packets than GPSR.

3.4 Energy Dissipation

In this thesis, the working is on event driven sensors. The sensors wait for an event to happen, and when an event happens in their sensing range, they forward the event information to the base station. In the sensing mode, their sensing hardware is working and it expends some energy. The sensing energy spent at sensor i is proportional to the time t passed.

$$E_{w_{i,t}}(t) = t * E_{waiting}$$

In this thesis, it assumed that sensors are distributed randomly in an area to be monitored. They sense an event happening in their sensing range and forward this information to the sink, which is also placed randomly at some point in the area. If the sink is in their communication range, they may pass the packet directly to it, or alternatively they can forward the packet to another sensor in their communication range, to be passed to the sink.

The energy spent in Sensor i , for sending information of length k to Sensor j which is at distance d is $E_{t_i}(k,d)$. Transmission energy has two parts, the transmitter electronics energy and the amplifier electronics energy. The transmitter electronics energy is similar to the receiving energy which is the energy needed for running transmitter electronics. Amplifier electronics energy is a multiple of packet length and some path-loss exponent (γ) of transmission distance. γ is two for ideal free space propagation that is the square of distance. In case there is attenuation on obstacles, γ can be three or up to five [45].

$$E_{t_{i,j}}(k, d_{i,j}) = E_{t_{elec}} * k + E_{amp} * k * (d_{i,j})^\gamma$$

In addition, the sensor i can be an intermediate sensor that forwards information received from other sensors towards the base station. The forwarding energy spent in sensor i , for forwarding information of length k to sensor j which is at distance d is energy spent for receiving this packet from a previous sensor in the forwarding chain plus energy spent for transmitting it to j .

$$E_{tot_{i,j}}(k, d_{i,j}) = E_{r_j}(k) + E_{t_{i,j}}(k, d_{i,j})$$

For an intermediate sensor, energy spent for receiving a packet is proportional to the packet length, which is the energy needed for running receiver electronics.

$$E_{r_i}(k) = E_{r-elect} * k$$

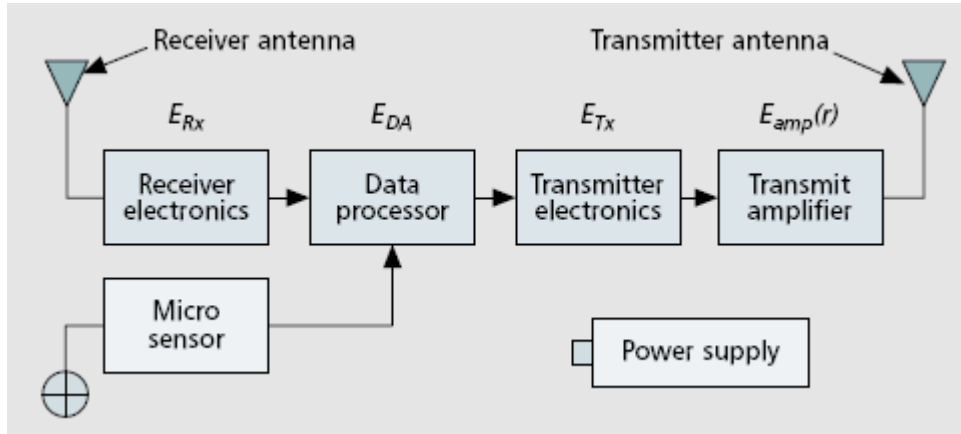

Figure 3 Simple radio energy model [46]

3.5.1 Beaconsing

Sensor nodes use beacons in order to maintain neighborhood and maintain routing tables. This beaconsing allows nodes to notice whether neighbor node is alive or died, thus network rapidly diagnose and solve the problems about node deaths.

IEEE 802.15.4 standard defines superframe structure controlled by the PAN coordinator to synchronize the nodes in the PAN. These superframes are bounded by two beacons sent by the PAN coordinator. Any device in the PAN which wants to send data during the contention access period (CAP) between two beacons competes with other devices using a slotted CSMA-CA mechanism. On the other hand, PAN coordinator may create contention free period (CFP) and allocate intervals for devices in order to provide guaranteed time slots (GTSs) for devices. This CFP is suitable for applications for low latency that requires specific bandwidth.

3.5.1.1 Data Aggregation Method

WSNs have large number of sensor nodes to form a network, thus there can be a lot of neighbor node in a small area. This leads to sensing same phenomena by many neighbor nodes. Summarization of data in such conditions is a requirement in order to reduce communication load of the network. Data aggregation is performed by coordinators such as cluster heads [47].

There are several kinds of data aggregation method such as clustering-based approach, tree-based approach, centralized approach, In-network aggregation etc. [48]. In cluster-based approach, nodes send their sensor data to CH, and then CH aggregates data and sends to remote sink [35]. In centralized approach, each node sends data remote leader node via shortest path with using multi-hop communication, then the leader node aggregates sensor data. In-network aggregation method executes aggregation by intermediate nodes of the multi-hop network for reducing resource consumption. In addition to combine data from different neighbors into a single packet, this method combines data with applying compression. Tree based approach forms an aggregation tree and all leaf nodes send data to CH, then CH send aggregated data to BS.

3.5.2 Routing in WSNs

In this method routing tables are updated on the nodes in order to maintain all paths in the network. In this method, route discovery is not executed due to awareness of current link-state and thus latency is relatively low compared to reactive routing method. This method leads to overuse of system resources by maintaining unnecessary paths that will be never used. Moreover, hello packet broadcasts increase routing overhead and cause wasteful energy consumptions for WSNs.

3.5.2.1 Reactive Routing

Reactive routing protocols used when a node has data packets to send to a particular address, route search is executed to find the path. The source node broadcasts route

request message and this message is flooded throughout the entire network. After route request message has arrived to destination node, this node sends a route reply message including selected path node IDs to source node. This process is called route discovery [49]. Then data communication from source to destination is executed over this route. In case of route breaks due to the failure, source node initiates new route discovery if necessary. And this part of reactive routing is called route maintenance. This method causes routing overhead with the flooding of route request message, but reduces usage of system resources for routing tables. Reactive routing usually used in MANETs because of frequent topology changes due to node mobility. In addition to MANETs, WSNs make use of reactive routing especially in query-based data dissemination demanded by a BS.

3.5.2.2 Hierarchical Routing

Hierarchical routing is used in WSNs in order to prolong network lifetime and provide scalability in such dense network. In a hierarchical architecture, nodes at the low level only sense data and send packets to high level nodes. In this method network separated into groups called clusters and each cluster has a special node called cluster head that manages its cluster. Cluster members form lowest level of hierarchy and cluster heads form upper level of the hierarchical network. Cluster heads have special tasks such as data aggregation and fusion, managing spatial reuse with time division multiple access (TDMA) in the cluster, data transfer to sinks etc. Thus cluster heads must have rich system resource as in clustering algorithms in [50]. Proposed method is related to energy-efficient clustering and it be explained clustering in the next part of this section.

CHAPTER 4

PROPOSED METHOD

4.1 Network Model

In this thesis it used 100 sensors in 100*100 areas. The base station is setup in center of area. All sensors have same information. It used homogeneity sensors. The thesis wireless sensor model is shown in Fig. 4.

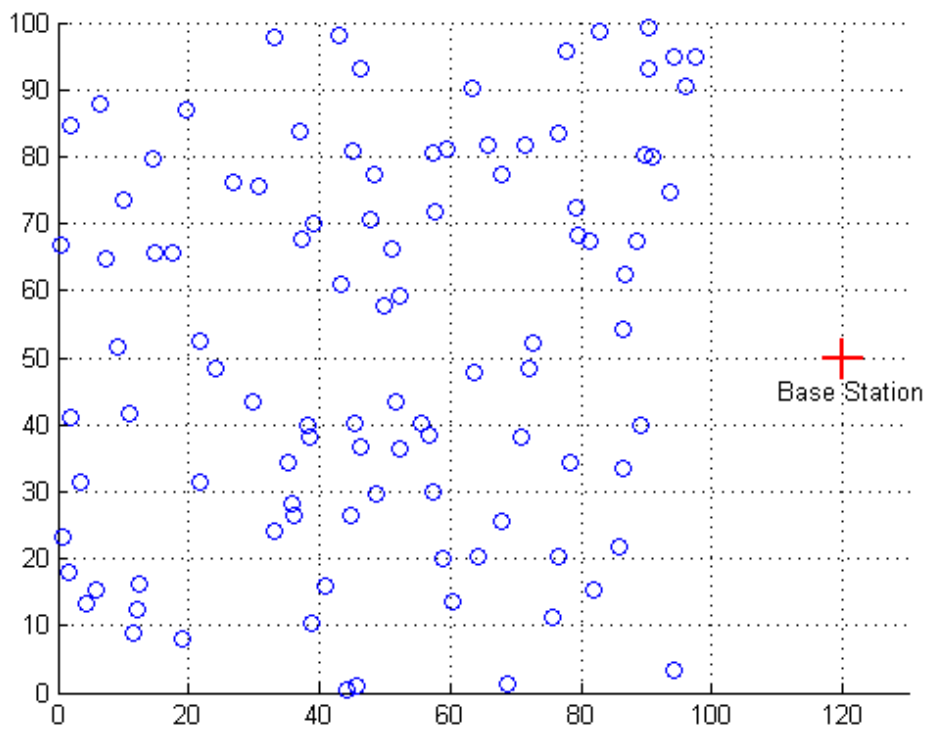

Figure 4 Network model used in proposed method.

In order to simulate energy efficiency of network it is assumed a simple model which is used in number of previous studies [40, 41]. Fig. 5 shows the radio model that used in the thesis method. It is assumed in this model that radio dissipates $E_{elec}=50\text{ nJ/bit}$ and transmitter amplifier is $E_{amp}=100\text{ pJ/bit/m}^2$.

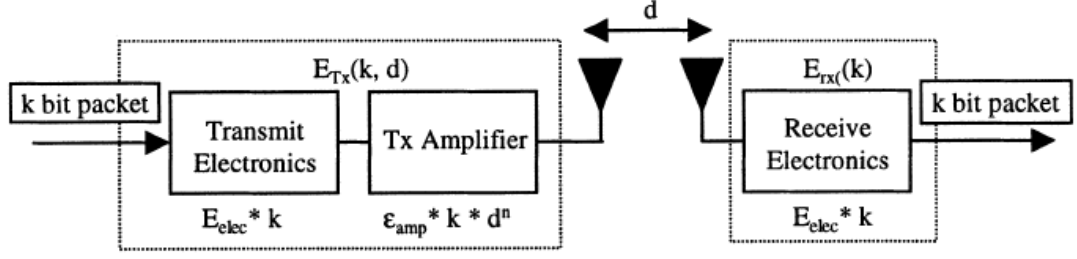

Figure 5 Radio model employed in the proposed algorithm

Whole of sensors need energy to transmit packet of k bits information to a distance d and to receive an information packet of k bits, is given as:

$$E_{Tx}(k, d) = E_{Tx-elec}(k) + E_{Tx-amp}(k, d) \quad (4.1)$$

$$E_{Tx}(k, d) = E_{elec} \times k + E_{amp} \times k \times d^2$$

$$E_{Rx}(k) = E_{Rx-elec}(k) = E_{elec} \times k \quad (4.2)$$

$$E_{Rx}(k) = E_{elec} \times k$$

In this network, it is assumed that the nodes are deployed to a square area with the size of $x \times x$; in the thesis simulations the default value of x is 100 meters. 100 sensors are deployed uniformly random distributed to this area, for example, as if they have been thrown from a plane. In the thesis the base station is placed at the center of the area by default. It is made tests with other positions of the sink inside or near the boundaries of the area. The energy expenditure in Node i per unit information transmission from Node i to j is assumed to be

$$E_{t,i,j}(k, d_{i,j}) = E_{t,elec} * k + E_{amp} * k * (d_{i,j})^\gamma \quad (4.3)$$

Where $E_{t,elec} = 50$ nJ/bit and $E_{amp} = 100$ pJ/bit/m³. In addition, the energy expenditure in Node j per unit information receiving from Node i to j is assumed to be

$$E_{r,i}(k) = E_{r,elec} * k \quad (4.4)$$

Where $E_{r,elec} = 150$ nJ/bit. These values are very similar to the ones in the energy consumption model used in Chang et al. [51]. The sensors sensing range (R_s) is assumed to be 10 meters and their communication range (R_c) is assumed to be 20 meters. The sink is considered to have an unlimited power supply. In addition, the sensors are assumed to have batteries with 0.2 Joules energy capacity. Events happen at a rate of, on average, one event per minute uniformly random distributed between

zero and two events per minute, at a randomly selected point in the area. The sensors that sense the event in their sensing range collect information about the event and send it to the base station. If they have no event to report, they wait until the next event happens and they spend idle waiting energy (E_{w_i}) of 50 nJ/min.

Packets generated from event monitoring are 128 bits; sensors forward the event information to the sink without any lag, so aggregation is not used. In some applications of MTE routing algorithms, simulations do not consider the receiving energy or the waiting energy. In these simulations, that is considering both for all algorithms. It have tested the success of this algorithm with the network lifetime metric as γ per cent of the original sensing area is continued to be monitored, and tested the cases where γ is equal to 98, 95 and 90. It's made ten simulations for each random network setup and compared the routing algorithm performances in the same area with the same events.

4.2 THE PROPOSED METHOD

In this thesis, it supposed every sensor has not same energy and near sensor to BS has low energy and far sensor from BS has high energy. In preloading near sensors to BS has a lot of value for probability to be cluster head and far sensor to BS has low probability to cluster head. There are some steps that below is explained.

4.2.1 Initial Phase

Initial phase puts the value for parameters in (4.1) and (4.2). For these parameter values, receiving a message is not a low cost operation; the protocols should thus try to minimize not only the transmit distances but also the number of transmit and receive operations for each message. The assumption is that the radio channel is symmetric such that the energy required transmitting a message from node A to node B is the same as the energy required transmitting a message from node B to node A.

4.2.2 Setup Phase

In setup phase, the sensors are putting randomly for 100*100 network area also the base station is outside of network area. Each sensor has different amount energy. The energy of the sensors are separated to 3 parts. Some of these sensors have less than the half of energy ($0.5E_o$), some of them has more than half and less than the E_o . And last remain sensors has greater than the E_o .

4.2.3 Cluster Head Selection

In LEACH algorithm nodes select their respective CHs according to the probability value from the node that announces itself as CH. Data collection and fusion and TDMA schedule is executed by CH, so CH nodes consumes much more energy than member nodes. In every round of the clustering process CH role have to be rotated among all nodes in order to obtain load balancing. LEACH algorithm runs in distributed manner, every node decides autonomously to become a CH without any centralized control. Each node determines a random value between 0 and 1 and threshold $T(i)$ compares the random value;

$$T(i) = \begin{cases} \frac{p}{1 - p \times \left(r \bmod \left(\frac{1}{p} \right) \right)} & \text{if } i \in G \\ 0 & \text{otherwise} \end{cases} \quad (4.3)$$

R is available round number; P is the percentage of cluster head which determined for whole network before and G is the set of sensor nodes which are not become CH in the last $1/p$ round. If random value is less than threshold $T(i)$ node becomes a cluster head for the current round.

This method is probabilistic and the nodes on the network regardless of its energy level to be CH. So, in the data gathering phase if node dies, whole cluster connectivity is affected until new clustering round would start.

Also, LEACH writes a central method to control the clustering process by the remote base stations proposed LEACH-C. Each node sends information about its energy level and the present location to the BS. In order to obtain load balancing and select node with high energy level as CH, BS computes the energy average of the network

and decides that nodes have energy below this average cannot be cluster heads for the current round. The data gathering phase of LEACH-C is identical to that of LEACH. LEACH-C performs better than LEACH on energy consumption but needs node position information and centralized control.

Since the sensors in the networks are energy constrained the lifetime of these networks has become a major concern. In order to prolong the networks lifetime cluster heads should be richer in sources than other simple nodes. Therefore intra cluster communication cost will also decrease due to the richer cluster heads. If possible, CHs should be placed close to most of the sensors in its clusters [52]. A new algorithm which aims to select more centralized cluster heads and increase efficiency of the network by decreasing the intra cluster communication costs is given in this section. As a first step of algorithm differs from LEACH by defining a set of probable cluster heads. LEACH algorithm gives equal chance to all nodes to become cluster head and in this case there may occur some undesired cases such as border nodes becoming cluster heads, or the nodes with no neighbors becomes cluster head. In order to prevent occurrence of these bad cases a set of probable cluster heads is defined according to connectivity levels of nodes. By this limitation it is aimed only more centralized nodes to have probability to become a cluster head. Therefore distance between nodes and their cluster heads will be small enough to achieve the aim of energy saving. Topology or neighbor discovery in sensor networks is generally done by letting nodes send hello messages in order to signal their presence [53]. In order to apply new connectivity algorithm nodes need to discover number of their neighbors and to do these nodes can send hello messages to all neighbors within a predetermined number of hops. Each node can count the number of hello messages it receives. After this process is completed connectivity algorithm can be applied to the network. Within the application of this algorithm there will be a neighbor discovery process at the beginning but on the other hand after the topology discovery is completed number of probable cluster heads will be determined. The nodes that do not have enough degree of connectivity will not have a chance to become a cluster head and they will not need to run the cluster head selection algorithm in any round. Only process that will be done by these nodes will be to find their appropriate clusters.

4.2.4 Development Generating

Development is an iterative procedure started by definition a cluster head node in sensors in simulation. Here, cluster heads are originate in the sensor slant. Clusters head sensor count is planned by adding cluster head sensors member and their member sensors up to the base station.

4.2.5 Steady-State Phase

LEACH provides an energy adaptive clustering algorithm by a dynamic topology with cluster heads. Leach operation is divided into rounds. Each of these rounds consists of a set-up and steady-state phase. During the set-up phase cluster heads are determined and the clusters are organized. During the steady-state phase data transfers to the BS occur. All of sensors send their sensed information to cluster heads and these cluster heads analyzes this information and sends it to the base station. The cluster head is selected as high probability value and this probability value is depended on the energy of sensors. If any sensor has more energy than the others this sensor has high probability value for Cluster head.

4.3 Evaluation of Performance

That tested and compared proposed method with (LEACH) Low Energy Adaptive Clustering Hierarchy. Also it gets good answer from simulation.

4.3.1 Performance Parameters

In this thesis the wireless sensor network parameters used that illustrated in table 1. This parameter is included the number of sensors, coordinate of x and y, primary energy, electronics energy and etc.

Table 1 Parameter that Used in the Thesis

Parameter	Value
Base station position	(120, 50)
N (number of nodes)	100
X	[0 100] ^m
Y	[0 100] ^m
E₀	0.5 J
E_{elec}	5 nJ/bit
E_{fs}	10 pJ/bit/m ²
E_{mp}	0.0013 pJ/bit/m ⁴
E_{da}	5 pJ/bit
Message Size	4000 Bit

4.3.2 Simulation Results and Analysis

Here illustrated that proposed method is high performance than the LEACH method. Also show that in proposed method saved a lot of energy for sending the information to base station.

4.3.3 Network Lifetime

Network lifetime is another consideration. Lifetime is highly dependent on the power supply of the sensors. There are various means of power supply such as battery and solar panel. Sensors are assumed to use batteries as power supplies in this study. A sensor consumes energy for generating data from targets, receiving from other sensors and transmitting to the other sensors. That is adopting the communication power consumption model used by Heinzelman et al. (2000). The energy required for generating and receiving data is constant per unit data; however it is not constant for transmission. In the adaptive transmission power model, energy required for transmitting unit data increases with distance. In order to send the data to a sensor over longer distances, an acceptable signal to noise ratio should be achieved by consuming more energy.

In Fig. 6 the number of alive nodes vs. round is illustrated. As shown in Fig. 6 it can be seen that proposed method is so better than the other method. In proposed method sensors are still alive to 1700 rounds. In LEACH protocol sensors were alive to 500 rounds.

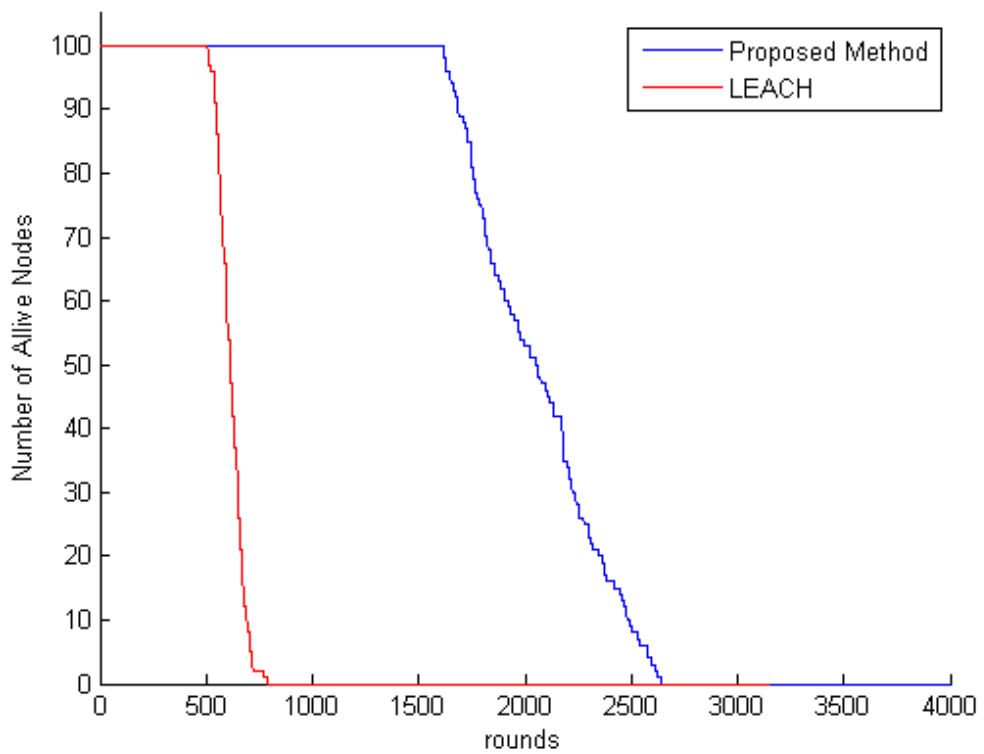

Figure 6 The number of alive nodes vs. round

In Fig. 7 the dead nodes vs. round is illustrated. As shown in Fig. 7 it can be seen that proposed method is so better than the other method. In proposed method sensors are dead after 1700 rounds. In LEACH protocol sensors were dead after 500 rounds.

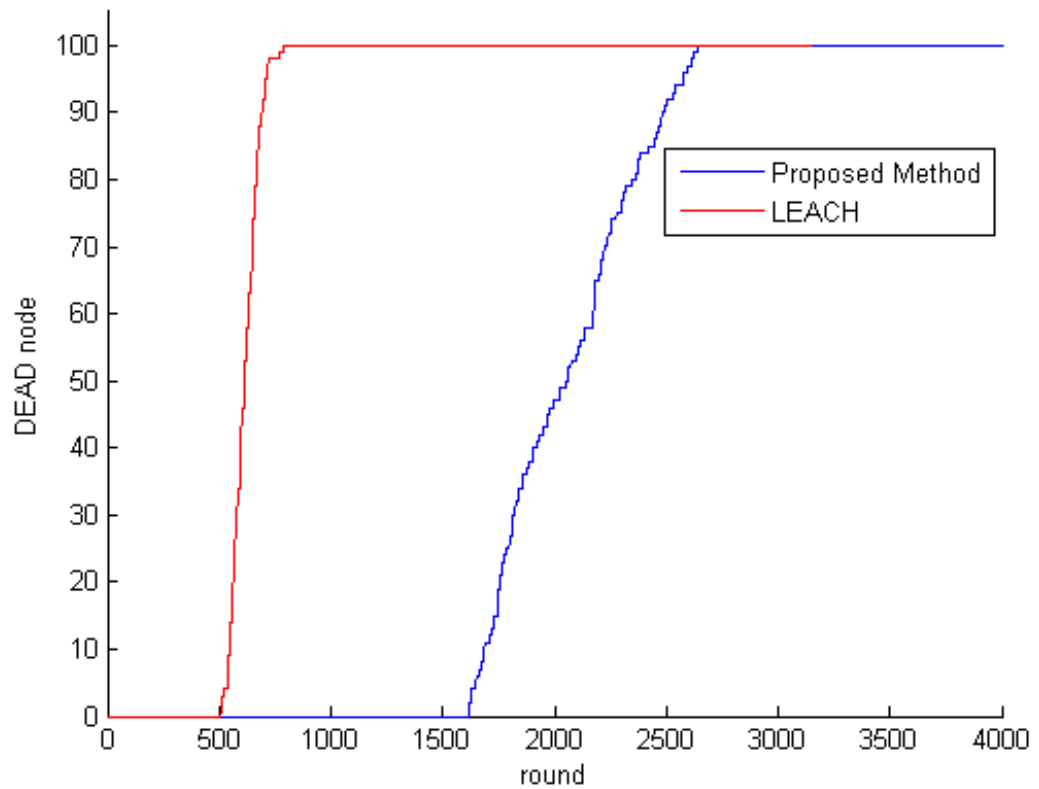

Figure 7 The dead nodes vs. round

Fig. 8 shows the number of packets received at base station vs. round. All sensor send information to base station. In first step all sensor send to cluster head and then cluster head sends to base station. As shown in this figure in proposed method the sensors send a lot of packets to base station. But in the other method they send little packets to base station.

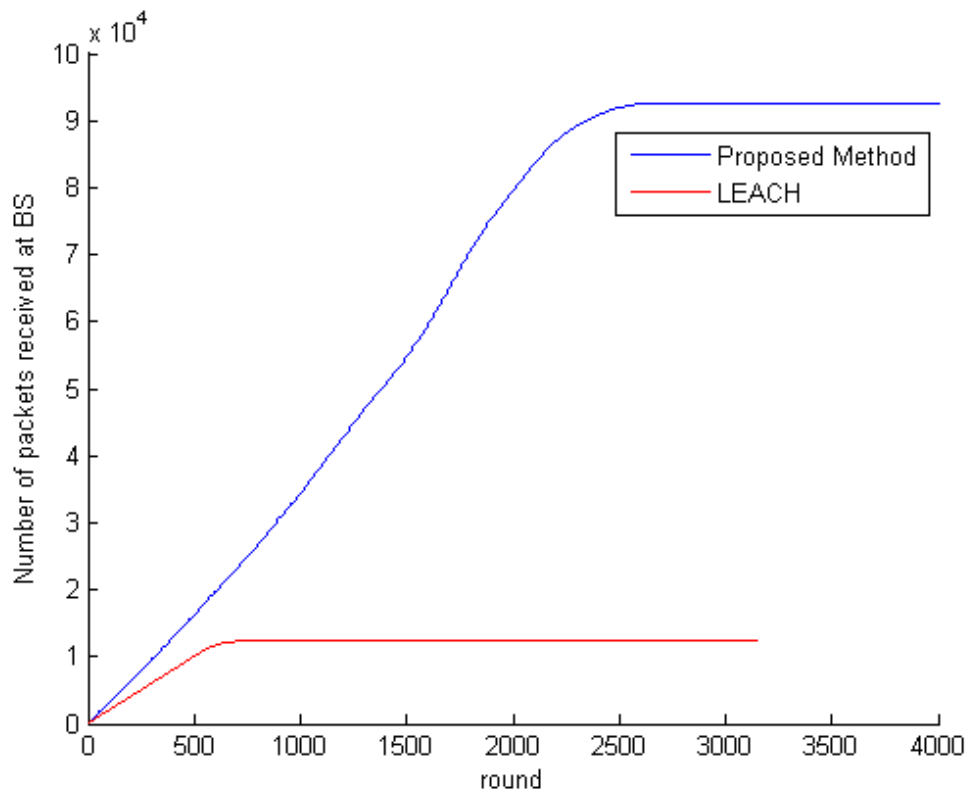

Figure 8 Number of packets received at base station vs. round

Fig. 9 shows the total dissipated energy vs. round. As seen in this figure in the same dissipated energy have a lot of round. This means, it spends a lot of round in the same energy. But in LEACH protocol in the same energy it has little round number. In here some sensor has directly communication or freely communication with base station and some sensor is not having freely communication with bases station.

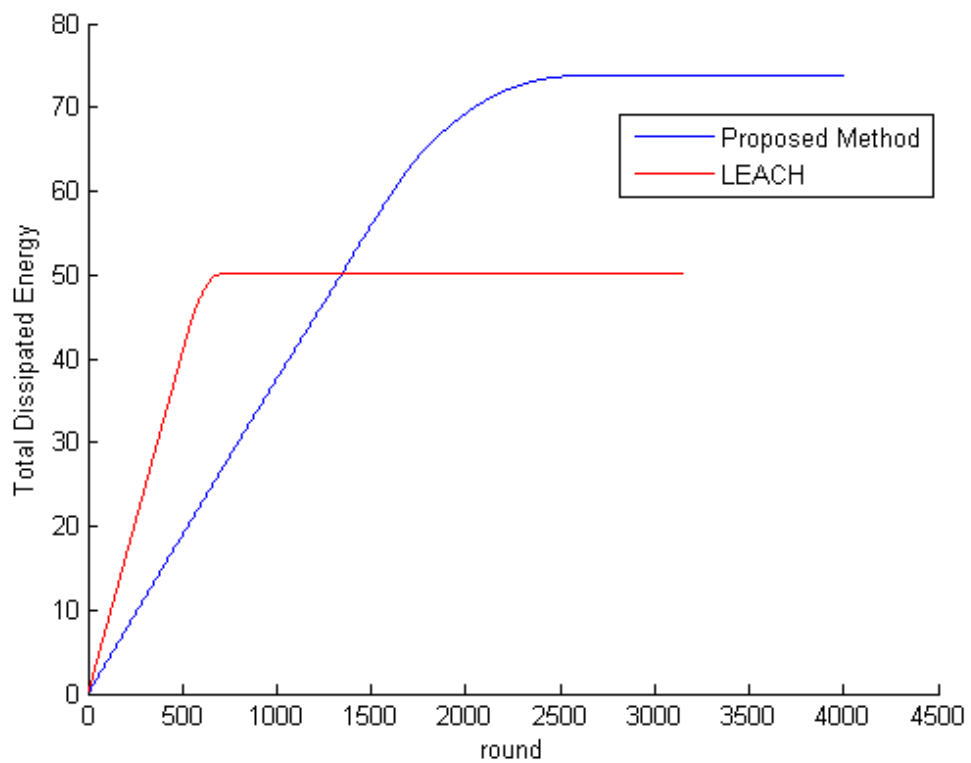

Figure 9 Total dissipated energy vs. round

CHAPTER 5

CONCLUSION

5.1 Conclusion

Acceptance of detection algorithms has been evaluated in 100x100 on regular and random topologies. The aim of this thesis is to provide energy saving nodes. The first goal of this thesis is to reduce the wireless sensor networks total energy consumption. The second goal is to increase the protocol reliability with network latency improvement as compared with the previous cluster-based protocols. The sensors are putting randomly for 100*100 network area also the base station is outside of network area. Each sensor has different energy amount. It is separate the energy of sensors to 3 parts. Some of these sensors have less than the half of energy ($0.5E_0$), some of them has more than half and less than the E_0 . And last remain sensors has greater than the E_0 . LEACH provides a random clustering method but there are some constraints that affect the clustering algorithm such as definition of number of clusters in each round. In LEACH based algorithms a P value defined as desired percentage of cluster heads is used to calculate threshold values, therefore it directly effects the cluster head selection. As a first step the optimum value should be determined and the parameters that depend on P value should be selected to reach best results. The difference between proposed method and LEACH method is the selecting of the node to be cluster head. In LEACH method each sensor has same energy value and same probability value to be CH, but in proposed method there are different value of energy and probability value. In proposed method near to base station has low energy and far sensor has high energy. After simulation that get good answer, that's mean after 1700 rounds the sensor begins to deeding but in LEACH protocol after 500 rounds. In future work it can implement this work on sensor chips; also it can put the base station in the inside of network area. If that select the separate area almost it can to save a lot of energy.

REFERENCES

1. **Newman M. E. J., (2006)**, “*Modularity and Community Structure in Networks*”, the National Academy of Sciences of the USA, USA.
2. **Chong C. Y., Kumar S. P., (2003)**, “*Sensor Networks: Evolution, Opportunities, and Challenges*”, Proceedings of the IEEE, vol. 91, pp. 1247-1256.
3. **Pottie G. J., Kaiser W. J., (2000)**, “*Wireless Integrated Network Sensors*”, Communications of the ACM, pp. 43.
4. **Abbasi A. A., Younis M., (2007)**, “*A Survey on Clustering Algorithms for Wireless Sensor Networks*”, Computer Communications, vol. 30, pp. 2826-2841.
5. **Heinzelman W. R., Chandrakasan P., (2002)**, “*An Application-Specific Protocol Architectures for Wireless Networks*”, IEEE Transactions on Wireless Communications, pp. 660-670.
6. **Chessa S., Santi P., (2001)**, “*Fault Diagnosis in Wireless Sensor Networks*”, ERCIM News, October.
7. **Staddon J., Balfanz D., Durfee G., (2002)**, “*Efficient Tracing of Failed Nodes in Sensor Networks*”, the First ACM International Workshop on Wireless Sensor Networks and Applications, Atlanta, USA.

8. **Meguerdichian S., Koushanfar F., Potkonjak M., Srivastava M., (2001),** "*Coverage Problems in Wireless Ad-Hoc Sensor Networks*", Proceedings of the IEEE Infocom.
9. **Meguerdichian S., Koushanfar F., Qu G., Potkonjak M., (2001),** "*Exposure in Wireless Ad Hoc Sensor Networks*", Proceedings of the ACM/IEEE International Conference on Mobile Computing and Networking.
10. **Zhao Y., Govindan R., Estrin D., (2002),** "*Residual Energy Scans for Monitoring Wireless Sensor Networks*", Proceedings of the IEEE Wireless Communications and Networking Conference.
11. **Deb B., Bhatangar S., Nath B. I., (2002),** "*A Topology Discovery Algorithm for Sensor Networks with Applications to Network Management*", IEEE CAS Workshop on Wireless Communications and Networking, Pasadena, USA.
12. **Zhao J., Govindan R., (2003),** "*Computing Aggregates for Monitoring Wireless Sensor Networks*", Proceedings of the International Workshop on Sensor Network Protocols and Applications.
13. **Ferrari G., Tonguz O. K., (2004),** "*Impact of Clustering on the BER Performance in Ad Hoc Wireless Networks*", Communications 2004 International Zurich Seminar, Zurich.
14. **Akkaya K., Younis M., (2005),** "*A Survey on Routing Protocols for Wireless Sensor Networks*", Elsevier Journal of Ad Hoc Networks.
15. **Younis M., Youssef M., Arisha K., (2003),** "*Energy-Aware Management in Cluster-Based Sensor Networks*", Computer Networks, vol. 43, pp. 649-668.
16. **Dasgupta K., Kalpakis K., Namjoshi P., (2003),** "*An Efficient Clustering Based Heuristic for Data Gathering and Aggregation in Sensor Networks*",

Proceedings of the IEEE Wireless Communications and Networking Conference, New Orleans, LA, USA.

- 17. Kwon T., Gerla M., (1999),** “*Clustering with Power Control*”, Proc. MILCOM, vol. 2, Atlantic City, NJ.
- 18. Qin Y., He J., (2005),** “*The Impact on Throughput of Hierarchical Routing in Ad Hoc Wireless Networks*”, Communications, ICC 2005. IEEE International Conference, vol. 5, pp. 16-20, 3010-3014.
- 19. Raj R., Ramesh M. V., Kumar S., (2008),** “*Fault Tolerant Clustering Approaches in Wireless Sensor Network for Landslide Area Monitoring*”, Proceedings of the 2008 International Conference on Wireless Networks, CSREA Press, vol. 1, pp. 107-113.
- 20. Beongku A., Papavassiliou S., (2001),** “*An Architecture for Supporting Geomulticast Services in Mobile Ad-Hoc Wireless Networks*”, Communications for Network Centric Operations: Creating the Information Force, IEEE, vol. 1, pp. 301-305, 28-31.
- 21. Khoshgoftaar T. M., Nath S. V., Zhong S., Seliya N., (2005),** “*Intrusion Detection in Wireless Networks Using Clustering Techniques with Expert Analysis*”, Proceedings Fourth International Conference, pp. 6, 15-17.
- 22. Wang Z., Liu L., Zhou M.C., Ansari N., (2008),** “*A Position-Based Clustering Technique for Ad Hoc Inter Vehicle Communication Systems*”, Man, and Cybernetics, Part C: Applications and Reviews IEEE Transactions, vol. 38, pp. 201 - 208.
- 23. Durresi M., Durresi A., Barolli L., Hsu F., (2005),** “*Parallel Architectures, Algorithms and Networks*”, Proceedings, 8th International Symposium, pp. 6, 7-9.

24. **Han S., Chan E., (2009)**, “*Hierarchy Energy Scan in Wireless Sensor Network Using in Network Aggregation*”, The International Journal of Distributed Sensor Networks, pp.1-23.
25. **Romer K., Mattern F., (2004)**, “*The Design Space of Wireless Sensor Networks*”, Wireless Communications, IEEE, vol. 11, no. 6, pp. 54-61.
26. **Akyildiz F., Su W., Sankarasubramaniam Y., Cayirci E., (2002)**, “*Wireless Sensor Networks: A Survey*”, Computer Networks, vol. 38, no. 4, pp. 393-422.
27. **Gosh A., Das S. K., (2006)**, “*Coverage and Connectivity Issues in Wireless Sensor Networks*”, Book Chapter: Mobile, Wireless and Sensor Networks: Technology, Applications and Future Directions, John Wiley & Sons.
28. **Heinzelman W. R., Chandrakasan A., Balakrishnan H., (2000)**, “*Energy-Efficient Communication Protocol for Wireless Microsensor Networks*”, Proceedings of the 33rd Hawaii International Conference on System Sciences, 2000, Maui, Hawaii, vol. 2, P. 10.
29. **Heinzelman W.R., Sinha A., Wang A., Chandrakasan A. P., (2000)**, “*Energy-Scalable Algorithms and Protocols for Wireless Microsensor Networks*”, Proceedings of IEEE International Conference on Acoustics, Speech, and Signal Processing, 2000 (ICASSP'00), Istanbul, vol. 6, pp. 3722-3725.
30. **Handy M.J., Haase M., Timmermann D., (2002)**, “*Low Energy Adaptive Clustering Hierarchy with Deterministic Cluster-Head Selection*”, Proceedings of the 4th International Workshop on Mobile and Wireless Communications Networks, pp. 368-372.

- 31. Hussain S., Matin A. W., (2006),** “*Hierarchical Cluster-Based Routing in Wireless Sensor Networks*”, International Conference on Information Processing in Sensor Networks (IPSN) Work-in-progress track, Nashville, TN, pp. 19-21.
- 32. Younis O., Fahmy S., (2004),** “*HEED: A Hybrid, Energy-Efficient, Distributed Clustering Approach for Ad Hoc Sensor Networks*”, IEEE Transactions on Mobile Computing, vol. 4, no. 4, pp. 366-379.
- 33. Younis O., Fahmy S., (2005),** “*An Experimental Study of Routing and Data Aggregation in Sensor Networks*”, Proceedings of the IEEE International Workshop on Localized Communication and Topology Protocols for Ad Hoc Networks, Washington, DC.
- 34. Bandyopadhyay S., Coyle E. J., (2003),** “*An Energy Efficient Hierarchical Clustering Algorithm for Wireless Sensor Networks*”, INFOCOM Twenty-Second Annual Joint Conference of the IEEE Computer and Communications, vol. 3, pp. 1713-1723.
- 35. Ding P., Holliday J., Çelik A., (2005),** “*Distributed Energy-Efficient Hierarchical Clustering for Wireless Sensor Networks*”, Proceedings of the IEEE International Conference on Distributed Computing in Sensor Systems, pp. 322-339.
- 36. Wang L., Xiao Y., (2006),** “*A Survey of Energy-Efficient Scheduling Mechanisms in Sensor Networks*” Mob Net. Appl., vol. 11, no. 5, pp. 723–740.
- 37. Younis O., Krunz M., Ramasubramanian S., (2006),** “*Node Clustering in Wireless Sensor Networks Recent Developments and Deployment Challenges Network*” IEEE, vol. 20, no. 3, pp. 20 –25.

38. **Sevgi C., (2009)**, “*Network Dimensioning in Randomly Deployed Wireless Sensor*” PhD thesis, Middle East Technical University.
39. **Chan H., Perrig A., (2004)**, “*An Emergent Algorithm for Highly Uniform Cluster Formation*” in Proceedings of the First European Workshop on Sensor Networks (EWSN), pp. 154–171.
40. **Boukerche A., Pazzi R. W. N., Araujo R. B., (2005)**, “*HPEQ a Hierarchical Periodic Event-driven and Query-Based Wireless Sensor Network Protocol*” pp. 560 –567.
41. **Powell O., Leone P., Rolim J., (2007)**, “*Energy Optimal Data Propagation in Wireless Sensor Networks*” Journal of Parallel Distributed Computing, vol. 67, issue. 3. pp. 302–317.
42. **Bandara H., Dilum M. N., Jayasumana A. P., (2007)**, “*An Enhanced Top-Down Cluster and Cluster Tree Formation Algorithm for Wireless Sensor Networks*” pp. 565 –570.
43. **Baker D., Ephremides A., (1981)**, “*The Architectural Organization of a Mobile Radio Network Via a Distributed Algorithm Communications*” IEEE Transactions on communications, vol. 29, no. 11, pp. 1694 –1701.
44. **Younis O., Fahmy S., (2004)**, “*Distributed Clustering in Ad Hoc Sensor Networks: A Hybrid, Energy-Efficient Approach*” In INFOCOM 2004. Twenty-third Annual Joint Conference of the IEEE Computer and Communications Societies, vol. 1, pp. 4 Vol. (xxxv+2866).
45. **Chatterjee M., Das S. K., Turgut D., (2002)**, “*WCA: A Weighted Clustering Algorithm for Mobile*” Ad Hoc Networks, pp. 193–204.

- 46. Lin C. R., Gerla M., (1997),** “*Adaptive Clustering for Mobile Wireless Networks*” IEEE Journal on Selected Areas in Communications, vol. 15, no. 7, pp. 1265 –1275.
- 47. Yoneki E., Bacon J., (2005),** “*A Survey of Wireless Sensor Network Technologies: Research Trends and Middleware’s Role*”, Technical Report, Number 646, Computer Laboratory, UCAM-CL-TR-646, ISSN 1476-2986.
- 48. Patil N. S., Patil P. R., (2010),** “*Data Aggregation in Wireless Sensor Network*”, IEEE International Conference on Computational Intelligence and Computing Research.
- 49. Johnson D. B., Maltz D. A., Broch J., (2001),** “*DSR: The Dynamic Source Routing Protocol for Multi-Hop Wireless Ad Hoc Networks*”, in Ad Hoc Networking, edited by Charles E. Perkins, Chapter 5, pp. 139-172, Addison-Wesley.
- 50. Lindsey S., Raghavendra C. S., (2002),** “*PEGASIS: Power-Efficient Gathering in Sensor Information Systems*”, IEEE Aerospace Conference Proceedings, vol. 3, pp. 1125-1130.
- 51. Chang J. H., Tassiulas L., (2004),** “*Maximum Lifetime Routing in Wireless Sensor Networks*” IEEE/ACM Transactions on Networking, vol. 12, p. 4.
- 52. Oyman E. I., Ersoy C., (2004),** “*Multiple Sink Network Design Problem in Large Scale Wireless Sensor Networks*”, Proceedings of the IEEE International Conference on Communications, Paris.
- 53. Moy J., (1994),** “*OSPF - Open Shortest Path First*”, RFC 1583.

APPENDICES A

CURRICULUM VITAE

PERSONAL INFORMATION

Surname, Name: Hassan, Sudad

Date and Place of Birth: 23 December 1970, Kirkuk

Marital Status: Married

Phone: +905534619364

Email: sudets@yahoo.com



EDUCATION

Degree	Institution	Year of Graduation
M.Sc.	Çankaya Univ., Computer Science	2015
B.Sc.	Kirkuk Univ., Science college	2008
Institute	Kirkuk Technical Institute., Mechanical Dept.	1990
High School	Al-Musala Secondary School	1988

WORK EXPERIENCE

Year	Place	Enrollment
2014- Present	Kirkuk Univ. Electronic Computer and Internet Center	Specialist Employee
1998-2003	Jordan, Monte Carlo Computer and Internet Center	Specialist

FOREIN LANGUAGES

Advanced English, Advanced Turkish, Advanced Arabic.

HOBBIES

RC cars, Paintball, Computer programming, Travel, Swimming, Fitness.