

**BLOCKER SECURITY SYSTEM WITH LEDs (BSSL)**

**A THESIS SUBMITTED TO  
THE GRADUATE SCHOOL OF NATURAL AND APPLIED  
SCIENCES OF  
ÇANKAYAUNIVERSITY**

**BY  
BURCU YAKIŞIR GİRİN**

**IN PARTIAL FULFILLMENT OF THE REQUIREMENTS FOR THE  
DEGREE OF  
MASTER OF SCIENCE  
IN  
THE DEPARTMENT OF  
ELECTRONICS AND COMMUNICATION ENGINEERING**

**JULY 2015**

Title of the Thesis: **Blocker Security System with LEDs (BSSL)**

Submitted by **Burcu YAKIŞIR GİRİN**

Approval of the Graduate School of Natural and Applied Sciences, Çankaya University.




Prof. Dr. Halil Tanyer EYYUBOĞLU  
Director

I certify that this thesis satisfies all the requirements as a thesis for the degree of Master of Science.



Prof. Dr. Halil Tanyer EYYUBOĞLU  
Head of Department

This is to certify that we have read this thesis and that in our opinion it is fully adequate, in scope and quality, as a thesis for the degree of Master of Science.



Prof. Dr. Celal Zaim ÇİL  
Supervisor

**Examination Date: 14.07.2015**

**Examining Committee Members**

Prof. Dr. Süleyman ÖZÇELİK

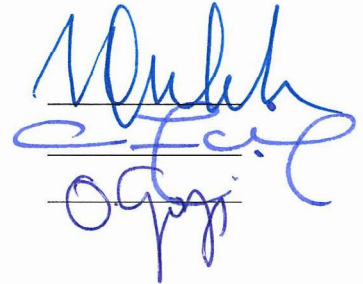
(Gazi Univ.)

Prof. Dr. Celal Zaim ÇİL

(Çankaya Univ.)


Assoc. Prof. Orhan GAZİ

(Çankaya Univ.)



## STATEMENT OF NON PLAGIARISM

I hereby declare that all information in this document has been obtained and presented in accordance with academic rules and ethical conduct. I also declare that, as required by these rules and conduct, I have fully cited and referenced all material and results that are not original to this work.

Name, Last Name : Burcu, YAKIŞIR GİRGIN  
Signature :   
Date : 14.07.2015

## **ABSTRACT**

### **BLOCKER SECURITY SYSTEM WITH LEDs (BSSL)**

YAKIŞIR GİRĞİN, Burcu

M.Sc., Department of Electronics and Communication Engineering

Supervisor: Prof. Dr. Celal Zaim ÇİL

July 2015, 91 pages

In this thesis, we designed and developed a prototype of a non-lethal system using light emitting diodes (LEDs) as the light source. The system, which is called a Blocker Security System with LEDs (BSSL), sends a light beam whose color and light intensity are changed in time (spectrally, temporally) according with certain pre-programmed patterns. It was observed in the literature that these changes in light patterns cause headache, nausea, dizziness and visual defects on people who are exposed to them. These effects are observed when the change in light pattern from the LEDs is fast enough so that human's brain could not process properly the information transmitted, and therefore, it cannot decode the changes in the speed they come. In the thesis, experiments are made, and measurements are performed by using the designed and developed Blocker Security System's prototype, and assessments of the experimental data have been performed to find the most effective patterns of the light. We searched the patterns that cause the desired effects on the people and tried to find the best pattern. The subsystems of the BSSL, mainly the LEDs, the optical system that guides the light beams from the LEDs, the cooling system, the battery system, the

body, and the LED drivers that generate the required light patterns were investigated. We focused mostly on the drivers that not only provide the necessary forward currents to the LEDs, but also generate the lighting patterns required from them. In doing this, we developed the embedded software required to form the lighting patterns through the driver.

**Keywords:** LED, LED Driver, Non-Lethal Weapons

## ÖZ

### ENGELLEYİCİ LEDLİ GÜVENLİK SİSTEMİ

YAKIŞIR GİRĞİN, Burcu

Yüksek Lisans, Elektronik ve Haberleşme Mühendisliği Anabilim Dalı

Tez Yöneticisi: Prof. Dr. Celal Zaim ÇİL

Temmuz 2015, 91 sayfa

Bu tez çalışmasında, ışık kaynağı olarak ışık yayan diyotlar (LED) kullanılan ve öldürücü olmayan bir sistemin prototipini tasarlayıp geliştirmiş bulunmaktayız. Engelleyici LED’li Güvenlik Sistemi (BSSL) olarak adlandırılan bu sistem, önceden programlanmış belirli paternlere göre zamanla rengi ve şiddeti değişen bir ışık hüzmesi göndermektedir. Literatürde, ışık paternlerindeki bu değişikliklerin, bunlara maruz kalan insanlarda baş ağrısı, uykusuzluk, baş dönmesi ve görme bozukluklarına yol açtığı gözlemlenmiştir. LED’ler tarafından oluşturulan ışık paternindeki değişikliklerin çok hızlı olduğu ve insan beyninin iletilen bilgiyi doğru şekilde işleyemediği ve bu yüzden de değişiklikleri geldikleri hızda çözemediği gözlemlenmiştir. Tezde, en etkili ışık paternlerini bulmak için, tasarlanan ve geliştirilen Engelleyici LED’li Güvenlik Sistemi’nin prototipi kullanılarak deneyler yapılmış, ölçümler gerçekleştirilmiş ve deneysel verinin değerlendirilmesi yapılmıştır. İnsanlar üzerindeki istenen etkilerine yol açan paternler araştırılmış ve en etkili patern bulunmaya çalışılmıştır. Gereken ışık paternlerini oluşturan BSSL’nin alt sistemleri, özellikle LED’ler, LED’lerden gelen ışık hüzmelerini yönlendiren optik sistemler, soğutucu sistemler, batarya sistemleri, gövde ve LED sürücülere araştırılmıştır. Özellikle, sadece LED’lere gerekli akımı iletmeyi sağlamakla kalmayıp, aynı zamanda aydınlatma paternlerini de oluşturan sürücülere yoğunlaşmıştır. Bunu yaparken de

sürücü aracılığıyla aydınlatma paternlerini oluşturmak için gereken entegre yazılım geliştirilmiştir.

**Anahtar Kelimeler:** LED, LED Sürücü, Öldürücü Olmayan Silahlar

## **ACKNOWLEDGEMENTS**

I express my sincerest thanks to my supervisor, Prof. Dr. Celal Zaim ÇİL. His confidence and positive attitude made it all possible. I appreciate all his contribution with his time, ideas and motivation for this study.

I express my deepest gratitude to my parents for their endless and continuous encourage and support throughout the years.

I thank my brother, Burak, for his creative ideas and for he has founded this subject which is an important milestone of this thesis.

I thank the Department of Electronics and Communication Engineering Faculty and staff and Graduate School of Natural and Applied Sciences for this opportunity to advance in our profession.

Once and for all, I thank my husband, İbrahim, for his love, support and understanding. He has always been by my side.



## TABLE OF CONTENTS

STATEMENT OF NON PLAGIARISM.....	iii
ABSTRACT.....	iv
ÖZ.....	vi
ACKNOWLEDGEMENTS.....	viii
TABLE OF CONTENTS.....	ix
LIST OF FIGURES.....	xii
LIST OF TABLES.....	xv
LIST OF ABBREVIATIONS.....	xvi
CHAPTER 1.....	1
1. INTRODUCTION.....	1
1.1. General.....	1
1.2. Scope of Thesis.....	5
CHAPTER 2.....	8
2. LEDS.....	8
2.1. What Is Light?.....	8
2.2. The History of LEDs.....	11
2.3. Fundamental Principle of a LED (Light Emitting Diode).....	13
2.4. State of the Art LED Technology.....	17
2.5. A Light System's Efficiency.....	22
2.5.1. Light Source Efficiency.....	23
2.5.1. Driver Efficiency.....	23
2.5.2. Optical Efficiency.....	23
2.5.3. Thermal Efficiency.....	24
2.6. LED Drivers.....	24

2.6.1. Linear Driver Circuits .....	27
2.6.2. Switched-Mode Driver Circuits .....	30
2.7. Optical Performance .....	37
2.7.1. Reflectors .....	38
2.7.1.1. Aluminum Anodize Reflectors.....	39
2.7.1.2. Vacuum Metalized Reflectors .....	39
2.7.1.3. Differences between Vacuum Metalized Reflectors and Aluminum Anodize Reflectors.....	39
2.7.1.4. Total Internal Reflector (TIR) Optics.....	40
2.8. Thermal Model .....	43
CHAPTER 3 .....	45
3. DETERMINATION OF TEMPORAL, SPECTRAL AND SPATIAL PATTERNS FOR THE LEDS .....	45
3.1. How a Change in Light Affects the Human Brain?.....	45
3.2. Determination of the temporal pattern of intensity of light of the BSSL ....	47
CHAPTER 4 .....	53
4. DESIGN AND IMPLEMENTATION OF THE BSSL .....	53
4.1. LED Array and Optical System.....	54
4.2. Designing The Electronic Control Unit of BSSL.....	66
4.2.1. The LED Driver Circuit .....	69
4.2.2. The Design of the Signal Circuit.....	75
4.2.2.1. The Signal Circuit's Hardware.....	75
4.2.2.1.1. The Microcontroller Unit.....	77
4.2.2.1.2. The Input & Output Unit .....	77
4.2.2.1.3. The Switching Unit.....	77
4.2.2.1.4. The DC Source & Power Unit .....	79
4.2.2.2. The Signal Unit Software .....	80

4.3. Tests and the Results .....	83
CHAPTER 5 .....	90
5. CONCLUSIONS and FUTURE WORKS .....	90
REFERENCES.....	1
APPENDICES .....	1
A. PHOTOMETRIC UNITS .....	1
B. PCB AND LAYOUT OF BSSL SIGNAL UNIT .....	2
• CIRCUIT LAYOUT .....	2
• PRINTED CIRCUIT BOARD.....	3
C. 3D MECHANICAL STRUCTURE OF BSSL .....	4
D. SOFTWARE OF BSSL SIGNAL UNIT.....	5
E. CURRICULUM VITAE .....	9

## LIST OF FIGURES

### FIGURES

<b>Figure 1</b> LED Incapacitator [3] .....	3
<b>Figure 2</b> Incapacitating flashing light apparatus [7].....	4
<b>Figure 3</b> LED-based incapacitating apparatus [8].....	5
<b>Figure 4</b> Classification of electromagnetic waves based on their wavelength [10] ...	9
<b>Figure 5</b> Variation of the vision sensitivity of the human eye depending on the night and day [11].....	9
<b>Figure 6</b> Human eye see according to the radiant flux curve that occurs as a result of the multiplication of luminous flux (radiant flux) of the candle flame and the sensitivity of our eye depending on the wavelength (luminous flux perceived by eye) [12].....	11
<b>Figure 7</b> Evolution of LED technology from the 1960s to the 2000s [15] .....	12
<b>Figure 8</b> A diode with forward bias applied, leading to current flow and the ejection of minority carriers into the majority carrier regions [16] .....	13
<b>Figure 9</b> Energy levels of LED against physical distance [16] .....	14
<b>Figure 10</b> An LED's luminous flux versus forward current [22].....	16
<b>Figure 11</b> LED Types [24] .....	18
<b>Figure 12</b> Spectral change of the light intensities of LEDs depending on the wavelength (for blue, green and red LEDs) [25] .....	19
<b>Figure 13</b> Components of an integrated LED lamp [28].....	22
<b>Figure 14</b> A LED Driver Circuit with a linear regulator.....	28
<b>Figure 15</b> The efficiency versus $V_o/V_{in}$ of a linear regulator [30].....	29
<b>Figure 16</b> A Linear LED Driver Circuit.....	30
<b>Figure 17</b> A Buck Type Switching Mode Driver .....	32
<b>Figure 18</b> A Boost Type Switching Mode Driver with a voltage-control [30].....	34
<b>Figure 19</b> A Boost Type Switching Mode Driver .....	34
<b>Figure 20</b> A Buck Type Switching Mode Driver that produces a negative output voltage .....	35
<b>Figure 21</b> All Types of Switching Mode Drivers [30] .....	36

## FIGURES

<b>Figure 22</b> A Typical LED Package [31].....	37
<b>Figure 23</b> MR16 LED Spot [32] .....	38
<b>Figure 24</b> Reflective films made of polymeric material [33].....	39
<b>Figure 25</b> Total Internal Reflection Lens (TIR Lens) [35].....	41
<b>Figure 26</b> Legacy Reflector [35] .....	41
<b>Figure 33</b> Different levels of physiological effects that are produced from visual impairment induced by various levels of irradiance (irradiance is defined as Watt/area, whereas intensity as Lumen/area) [8] .....	50
<b>Figure 34</b> The BSSL system schematic .....	54
<b>Figure 35</b> Red, Green and Blue LEDs on different chips .....	56
<b>Figure 36</b> Red, Green, and Blue LEDs on one chip.....	56
<b>Figure 37</b> Federal 5050 Series LED chip [48] .....	58
<b>Figure 38</b> Wiring Diagram of LED array used in the BSSL.....	60
<b>Figure 39</b> Front view schematic of the LED array PCB used in the BSSL .....	60
<b>Figure 40</b> The lens as the primary optic on Edison Federal Series LED .....	62
<b>Figure 41</b> Photometric test result with a single-angle reflector for the same radiation intensities of the red, green, and blue LEDs .....	63
<b>Figure 42</b> Photometric test result with single-lens for the same radiation intensities of the red, green, and blue LEDs .....	64
<b>Figure 43</b> "Human's eye sensitivity function and luminous efficacy, measured in lumens per watt of optical power" [49].....	65
<b>Figure 44</b> Secondary optics of the BSSL .....	66
<b>Figure 45</b> Block Schematic for the Electronic Control Unit (ECU) of the BSSL ....	67
<b>Figure 46</b> Detailed Block Schematic of the Electronic Control Unit.....	68
<b>Figure 47</b> Forward voltage vs. forward current for white series [48] .....	70
<b>Figure 48</b> Forward voltage vs. forward current for other colors [48] .....	70
<b>Figure 49</b> Normalized forward voltage vs. junction temperature [48].....	71
<b>Figure 50</b> Luminous flux vs. forward current for white series [48] .....	72
<b>Figure 51</b> Schematic of the buck-type SMPS Regulator using HV9910B [50].....	74
<b>Figure 52</b> Buck type LED driver circuit we chose for the BSSL, a no name buck driver available on the market .....	74

## FIGURES

<b>Figure 53</b> Layout of the Signal Circuit of the BSSL.....	76
<b>Figure 54</b> Switching Circuit of the BSSL, each driver provides the current to the individual LEDs of red, green, blue and white color on 3 different chips .....	79
<b>Figure 55</b> Software Flowchart for generating light pulse patterns for the BSSL.....	82
<b>Figure 56</b> The spread of light on a flat surface .....	83
<b>Figure 57</b> Light pulses of BSSL at 7 Hz .....	85
<b>Figure 58</b> Light pulses of BSSL at 10 Hz .....	85
<b>Figure 59</b> Light pulses of BSSL at 15 Hz .....	86
<b>Figure 60</b> Light Pulses of BSSL at most effective frequencies .....	86
<b>Figure 61</b> Lighting tests of BSSL.....	88
<b>Figure 62</b> Thermal tests of the BSSL .....	89

## LIST OF TABLES

### TABLES

<b>Table 1</b> Comparison of Light Sources [26] .....	21
<b>Table 2</b> The Effects Caused by a Single Exposure to Continuous Light [8].....	51
<b>Table 3</b> Luminous Flux at 350 mA of Federal 5050 Series [48].....	61
<b>Table 4</b> Lux and Lumen values of BSSL with 5 degrees lens at 20 meters .....	84
<b>Table 5</b> Most effective patterns' frequency and period values.....	87

## LIST OF ABBREVIATIONS

BSSL	Blocker Security System with LED
LED	Light Emitting Diode
IOS	Intelligent Optical Systems
PWM	Pulse Width Modulation
PIC	Programmable Integrated Circuit
EHP	Electron-Hole Pair
LIFI	Light Fidelity
RGB	Red Green Blue
IR	Infrared
ROI	Return On Investment
EMI	Electromagnetic Interference
EMC	Electromagnetic Compatibility
SMPS	Switch Mode Power Supply
SSL	Solid State Lighting
TIR	Total Internal Reflector
COB	Chip-On Board
HDF	High Density Flux
PMMA	Poly (Methyl Methacrylate) Acrylic
MPE	Maximum Permissible Exposure
HBLED	High-Brightness LED
LOR	Light Output Ratio
ECU	Electronic Control Unit
ADC	Analog To Digital Converter
UV	Ultra Violet
PLED	Polymer LED
MCPCB	Metal Core Printed Circuit Board
LCD	Liquid Crystal Display
EHP	Electron – Hole Pair



EEG	Electroencephalography
PS	Photosensitivity
BOM	Bill of Material

## CHAPTER 1

### 1. INTRODUCTION

#### 1.1. General

Recently, it has been one of the primary goals of the governments to be able to solve the social events without giving any damage to the people and the environment. For this purpose, in the cases that the governments need to overpower the criminal in peace operations, they aim to overpower them without any permanent harm by using special devices called non-lethal weapons. The first example of these weapons were chemical weapons presumed to be used during the Gulf War in 1991 and have been used frequently in the World since 2000. The recently reached technological developments for such weapons are observed to allow the security powers to succeed in the situations and in the scenarios which they couldn't prevent before with the conventional weapons. Flexibility and competence of these weapons to solve the said problems without risking the human life and not giving any permanent harm mean that they have the potential to be extensively used in the future [1].

These weapons can be used when it is necessary to discourage the people, to delay or prevent it in the civil commotion, in the social events and peace operations and in any case where a potential lethal weapon is not needed and not allowed. Non-lethal weapons are divided into two groups :

- Non-lethal weapons against objects, which are the weapons which generally destroy the electronic systems or make them out of function. They also make the electronic controls of the mechanical systems out of function and paralyze or destroy the mechanical equipment. They have many types such as the chemical and biological weapons; the weapons having electronic sensors with laser and blunter which are against light measurement and optical systems; and non-lethal electromagnetic technologies, non-nuclear electromagnetic weapons.

- Non-lethal weapons against human, which are the laser weapons dazzling people's eyes; high-powered microwave devices which can deactivate the communication of the enemy as well as burn the visceral organs of people; acoustically irradiation devices with high power and very low frequency and impact chemical lasers and ultrasonic wave devices. They are non-lethal weapons that are various and have different fields of use and purposes, so these weapons are considered to be developed much more in time [1].

The non-lethal weapon we designed and developed as a prototype in this thesis is called a Blocker Security System with LED (BSSL). The BSSL will be a system that we can describe as a device that generates a high-intensity flashing light that occurs randomly in intensity and colors in time in accordance with a pre-determined pattern. The changes in intensity and color of this light are arranged to be faster than the time needed for eye and brain of human to process properly. The light is not only fast but also very brilliant and well-focused to prevent focusing of the eye. The BSSL is intended to cause the results like headache, nausea, vomit, nervousness, temporary visual defect, epilepsy (impairment regarding the functions of conscious behavior, sense, movement or perception for a certain period of time), vertigo (dizziness and losing the behavior sense temporarily) due to the impacts emitted in varying intensity and colors.

Our aim in developing the BSSL is to introduce the system as a part of the existing weapons in the control of social events and any kind of operation carried out around the residential areas or in order to provide effective deterrence together with these weapons and to overpower the target person for a short time without causing death or permanent injury of him/her. It is aimed to stop or slow or mislead the target person with minimum damage by overpowering him/her without causing death and permanent injuries and at the same time not leaving permanent trails that disturb the environment.

It is clear that the projects like BSSL studies have been seen in the literature and the LED Incapacitator shown in Fig. 1 is one of them. According to the Homeland Security Department of United States , the LED Incapacitator functions as following: "By synchronously subduing the subject both physiologically (temporarily making him

blind) and psychophysically (confusing him). An embedded range finder quantifies the distance to the closest couple of eyeballs. Later on, a “governor” adjusts the output and pulse train (a set of pulses and rests) to a level, frequency, and period that are efficacious, but secure. The colors and pulses alter ceaselessly, not giving time for the brain or eyes to adapt. A few minutes later, the impacts fade out" [2].



**Figure 1** LED Incapacitator [3]

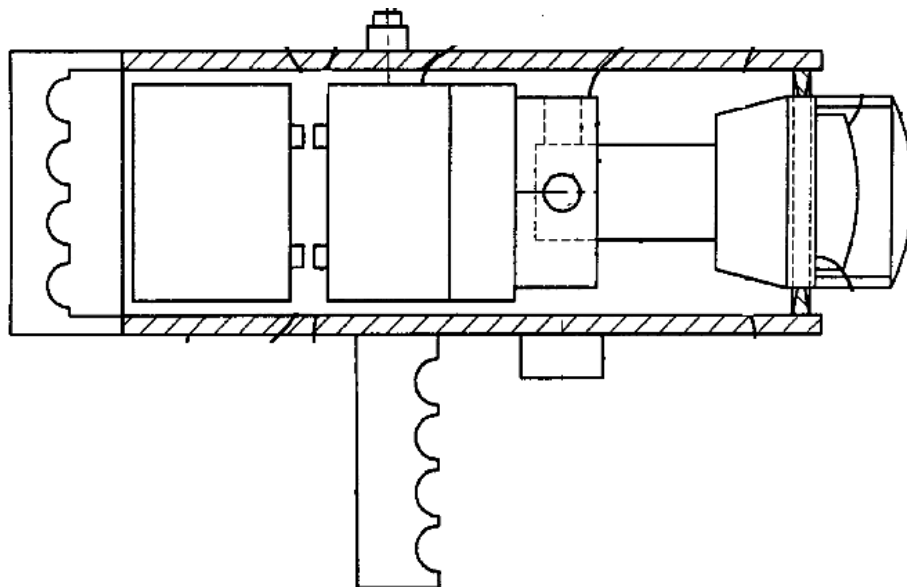
The inventor and manufacturer of Intelligent Optical Systems (IOS), which is another non-lethal weapon, was awarded a contract by the Department of Homeland Security's Small Business Innovation Research Office of the United States. Since August, 2007, the first stage of the contract, which required the development of a prototype, was fulfilled. Later stages include testing of the prototype by the Institute of Nonlethal Defense at Pennsylvania State University, and the development of a manufactured version, intended to be more compact and easier to carry [2], [ 4 and 5]. The device is being employed in confrontations at border passes for the suspected outlawed foreigners or drug runners among the other possibilities [2]. Intended users involve air marshals, border patrol officers, the other officers with the Transportation Security Administration and the customs officers [3]. It is declared that "For a few seconds, the officer has a tactical advantage and will in fact surround to subdue or control the potential opponent, from distances of up to 30 feet" [6].

A researcher in nonlethal technology at the University of New Hampshire, says "If you confuse or distract a person and make them to look away, then they can't focus on

their duty, which could intend a weapon at someone, or looking at a display with critical information, or dialing a phone." [5]. A LED-based device could be safer than a laser-based device aimed to obtain the same impacts, because having an eye-safe wavelength with a laser has been very challenging[5]. It is also verbalized that the existence of a range-finder and circuitry to alter the density of the light depending on the range in the LED device improves its safety. The ideal purpose for nonfatal technologies is to make them scalable [5].

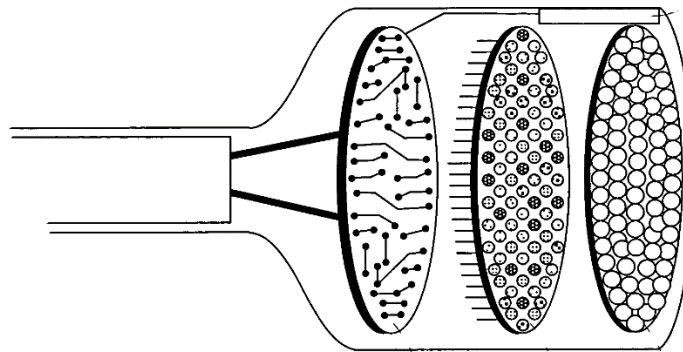
In the thesis, we began our research by first making a patent search regarding LED Incapacitator. The patents registered so far are:

1-Rubtsov, Vladimir. "U.S. Patent: Incapacitating flashing light apparatus and method." Appl. No. 10/993,698. USPTO Patent Full-text and Image Database. Feb. 20, 2007 [7]. Incapacitating flashing light apparatus shown in Fig. 2 and method for using a light source to incapacitate a subject in which the light source strobes by a spatial scanning through a pattern and a temporal flashing at a rate sufficient to cause incapacitation. The strobing (meaning both spatial scanning and temporal flashing in a pattern) is to prevent the subject from escaping the effects. The flashing is timed so that each flash point in the pattern will flash at a rate and sequence to cause incapacitation. In a preferred embodiment, the light source is an array of LEDs or laser diodes [7].



**Figure 2** Incapacitating flashing light apparatus [7]

2-Rubtsov, Vladimir. "U.S. Patent: LED-based incapacitating apparatus and method." Appl. No. 11/269,074. USPTO Patent Full-text and Image Database. Mar. 10, 2009 [8]. LED-based incapacitating apparatus is shown in Fig. 3. This apparatus applies the method of using a light source to incapacitate a subject by a pattern of temporal flashing and/or color flashing of the light source. The light source is preferably an array of light emitting diodes. A range finder may be used to control the light output from the light source to avoid exposing a subject to light energy beyond a maximum permissible exposure threshold [8].



**Figure 3** LED-based incapacitating apparatus [8]

In both of these patents the most critical aspect, the temporal intensity and color pattern of the light, are not given. Also the generation of the light in the temporal and spatial pattern required is another challenge. Therefore, the contribution in this thesis we tried to make is to design and develop the proper strobing light device with the design of the driver circuits to drive the LEDs in accordance with the temporal intensity and the color pattern that can be controlled by a software, and with the proper optical and mechanical systems to provide the desired light effects; and to find the proper temporal and spatial pattern of the light that can cause the desired effects on human.

## **1.2. Scope of Thesis**

The scope of this thesis consists of the studies and the researches carried out aiming to find the most effective temporal and spatial light patterns of the intensity and the color from a lamp using LEDs, the BSSL, to be directed to people to incapacitate them without causing any permanent harm. The lamp that generates the required pattern of

the light and the light beams required are also designed, developed and manufactured. We built a prototype BSSL. The BSSL makes use of the limitation in the capability of the eye and the brain to sense, transmit and process the visual information of changing intensity and color in the rate they are generated. If the change in the light occurs faster than the processing through the eye and brain system then the person exposed to this light pattern may show a number of reactions from temporary dizziness, disturbance sense and temporary visual loss to blackout [9]. Hence, when exposed this light pattern we expect that people are incapacitated for a certain time period.

In the thesis we first searched the literature in Chapter 2. The fundamental operational principles of an LED, the technological developments that make the LEDs to produce white light possible, the performance parameters of LEDs, and the use of the LED in lighting applications, constructing a LED lamp that can be used in illumination application, the parts that make an integrated LED lamp are all covered in this Chapter. We reviewed the LED drivers, analyzed the different types, compared their advantages and disadvantages regarding the efficiency and the lifetime. We also analyzed the optical systems, driver systems and other parts that are used in implementing integrated LED lamp. Standards that are applicable to the LED illumination, modules and integrated LED lamps are also cited here.

Chapter 3 comprises the review of the studies on how a temporal and spatial change of a light from the BSSL generates effects on a human being. In this chapter the first section describes how a change in light affects the human brain, and the second section contains the search for the temporal pattern of light that affects the eye and brain.

In Chapter 4, we explained our design of the BSSL. Actually this chapter covers the subjects that we mainly contributed to in this thesis. The driver, the optical system, and the embedded software to generate the desired patterns of the light emitted by the BSSL to incapacitate a person are given in detail in this chapter. If we give some detail, we first designed, developed and manufactured the BSSL that can provide the changes in color and intensity of light required in accordance with the pattern in time embedded in a microprocessor effectively. The pattern in the microprocessor is applied to the driver of the LED lamps to drive them accordingly. Subsequently, having the BSSL available with the capability to produce the light output required, we started to search

the best temporal pattern. In our BSSL design, the LEDs with various colors and powers were connected as a row and the light beams they produced were turned into the beam with the light, lens and reflecting setups emitted by these LEDs. The LEDs were driven with proper currents and voltages using the driving circuits developed and the light effects in the desired distances were obtained. The signals with pulse width modulation (PWM) of the desired frequency and patterns were applied to the driving circuits. The PWM signals required have been produced at the desired frequency and intensity and color patterns with the use of a PIC. We developed the embedded software required.

The patterns of LED flashing and light intensity that create dizziness, losing control, vertigo, vomiting, nausea and temporary blackout in the people who are exposed to the light of BSSL were tried to be created by analyzing the studies and the researches particularly on vertigo issue. A number of designs that may show differences in size depending on the purpose have been made and after the electronic, optical and mechanical design of the device, we tested compatibility to the eye in the laboratory on ourselves. We also documented our experiments and provided the data recorded in this chapter.

The last chapter is the Conclusion, where we simply listed what we did in this study and we indicated the future works on the subject.



## CHAPTER 2

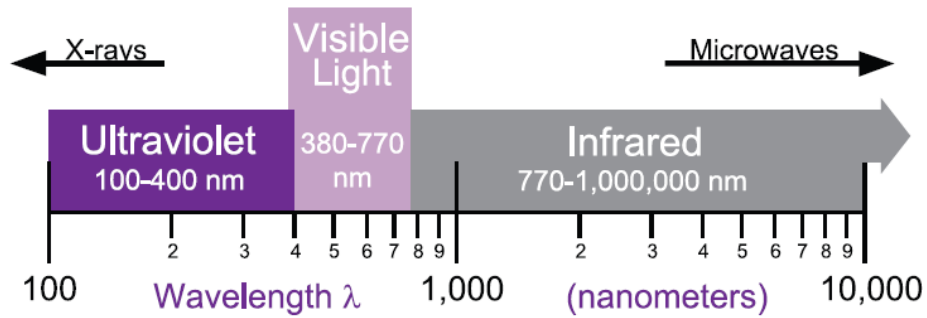
### 2. LEDES

In the past few years, LED technology has continued to improve, particularly in the area of general lighting. This achievement is not very surprising, since LEDs have countless advantages over traditional lighting technologies. They are small, compact, have a very long operation life and can be used in highly multiple ways. For over 30 years, LEDs have been used in diverse applications, such as for industrial systems, vehicle lights, advertising, systems of traffic lighting, display brightness of TVs and cell phones. Technical development of LED continues to proceed. During the recent years, glowing effectiveness of the white LEDs has increased to 130 lumens per watt and over. This is a tendency to proceed in the future as well.

Operation life of LEDs, correction of power constituent, thermal sensitivity, color stability are among the issues remain to be improved for the researchers. This chapter introduces the definition of light, the operation of light emitting diode and historic development. Next section is LEDs' basic knowledge and another section is LEDs' light colors, the innovation of LEDs with respect to the other light sources. The final part covers optical methods to shape light from a LED Lamp, thermal effects and cooling methods of the the LED drivers.

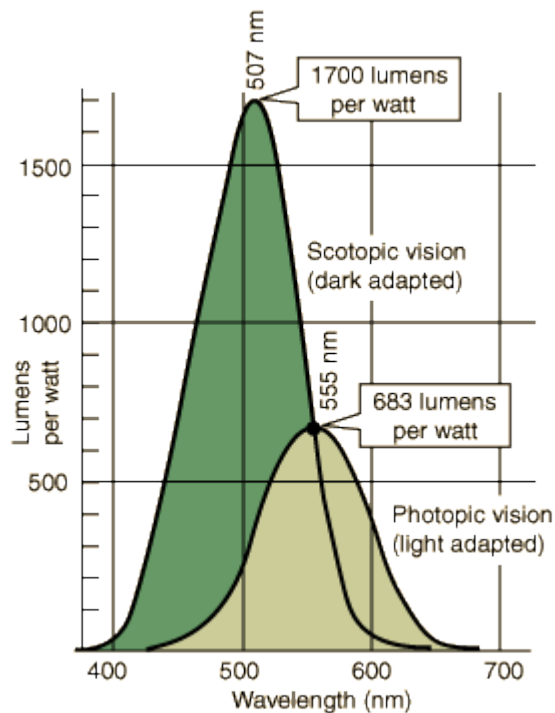
#### 2.1. What Is Light?

Light is an electromagnetic wave. The electromagnetic wave between 380 nanometer and ( $1\text{nm}=10^{-9}\text{ m.}$ ) 770 nm, which is called the visible range, can be perceived by the human eye.



**Figure 4** Classification of electromagnetic waves based on their wavelength [10]

The lights that beyond these two limits are called infrared and ultraviolet lights, which are not visible to the human eye. Human eye cannot perceive the lights in various wavelengths which are in the visible region in nature with the same sensitivity. The wavelengths to which our eye is sensitive during the day and the night are different from each other as well. Scotopic vision sensitivity and photopic vision sensitivity are shown in Fig. 5. In the figure, vertical axis indicates how much of the light power is seen by our eye per watt and horizontal axis indicates the wavelength of the light. As seen, the wavelength to which our eye is the most sensitive is 507 nm (yellow-green) at night and 555 nm (green) during the day.



**Figure 5** Alteration of the vision sensibility of the human eye depending on the night and day [11]

Day light is perceived by the conical sensors in the human eye while the light in night is perceived by the cylindrical sensors. The main difference between the vision sensitivity of the night and day is originated from this. As seen in Fig. 5, light of 1 watt power at 555 nm is equal to 683 Lumen. Visible light power is expressed by Lumen unit. Here the total photons generated in a second is the radiated power and is measured in watts. Lumen, also a unit of light power, but it is normalized to our eyes and it represents the total number of visible photons emitted in a second, i.e. the total radiated power perceived by our eyes.

The light behaves as an electromagnetic wave and at the same time behaves as a particle. The smallest particles of the light are called photons. Energy of a photon is equal to the multiplication of Planck's constant and the frequency of photon,

$$E = h \times \nu \quad (2.1)$$

The frequency of the light is obtained dividing the velocity of light with the wavelength,

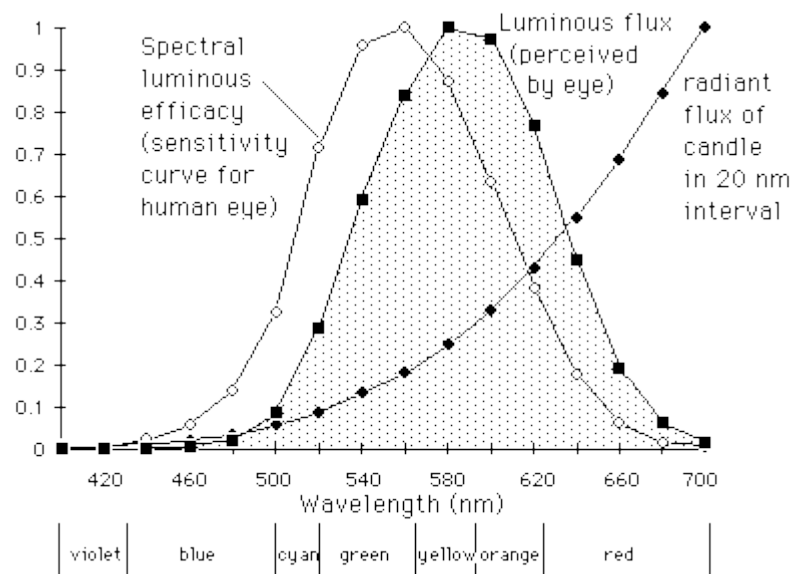
$$\nu = c / \lambda \quad (2.2).$$

The velocity of light is about  $3 \times 10^8 \text{ m/s}$  in space. When the frequency of light increases, then its wavelength decreases. There are many photons in a light beam. These photons move at the speed of light in space. Their velocity in any substance on the other hand varies from their velocity in space. The product of the number of photons produced in a second and the energy of a photon give the power of a light beam. This is called the luminous flux.

As given in Fig. 5, the human eye is the most sensitive to the light at 555 nm; it can sense 10 photons at this wavelength per second while it can feel the same intensity for 214 photons per second at 450 nm at which it is less sensitive and it can sense the light at 650 nm only if 126 photons arrive per second.

Human eye perceives the color of any light source according to the result of the multiplication of the vision sensitivity and the spectrum of the luminous flux of the

light source as explained in Fig. 6. As seen in Fig. 6, the energy of a candle light is perceived as yellow rather than red although it is more powerful at red wavelengths.



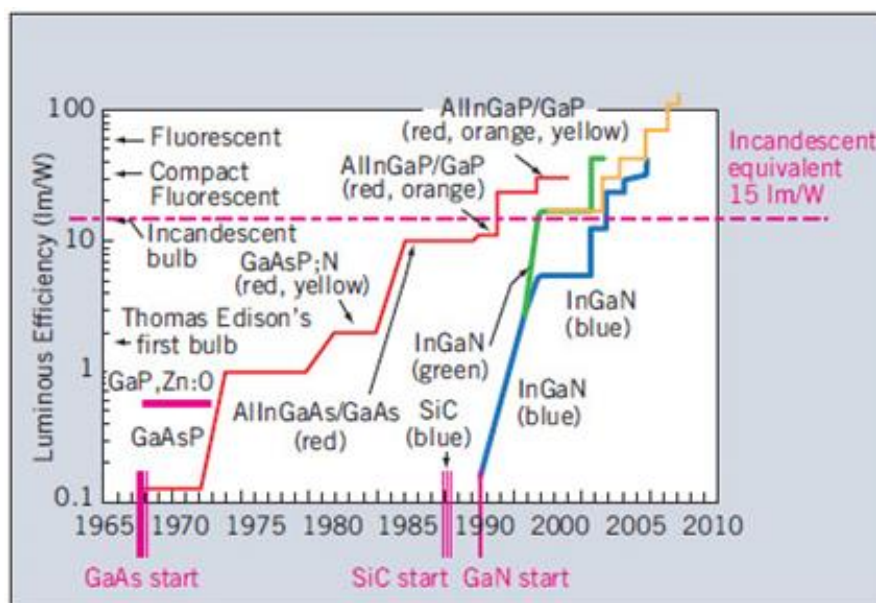
**Figure 6** Human eye see according to the radiant flux curve that occurs as a result of the multiplication of luminous flux (radiant flux) of the candle flame and the sensitivity of our eye depending on the wavelength (luminous flux perceived by eye) [12]

## 2.2. The History of LEDs

The Illuminating Engineering Society defined LED as “Light Emitting Diode (LED) is a p-n junction semiconductor device that emits incoherent optical radiation when forward biased. The optical emission may be in the ultraviolet, visible, or infrared wavelength.” [13].

In 1907, Henry Joseph Round discovers that inorganic materials can glow with the application of an electric current. . He publishes his discovery in the paper called "Electrical World" in the same year. Since, however, he focused on working mainly on a new direction-finding system for marine transport, this discovery is forgotten in the beginning. Then the Russian physicist Oleg Lossev re-observes the "Round Effect" of light emission in 1921. In the following years, from 1927 to 1942, he analyzed and defined this phenomenon in a more detailed way.. The French physicist Georges Destriau discovers light emission in zinc sulfide in 1935. In honor of the

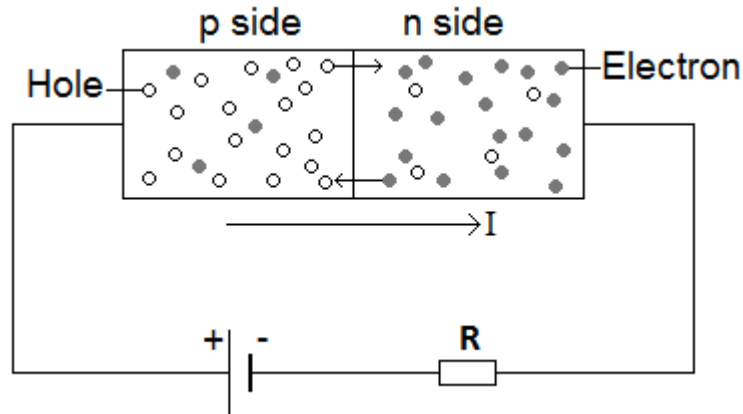
Russian physicist, he calls the effect "Lossev light". Today Georges Destriau is credited as the inventor of electroluminescence. In 1962, the first red luminescence diode (type GaAsP), developed by an American, Nick Holonyak of General Electric, was launched into the market. This first LED in the visible wavelength area marks the birth of the industrially-produced LED. Later in 1960s and 1970s, the performance and efficiency of the LEDs went on to improve. As a consequence of the development of new semiconductor materials, LEDs were manufactured in green, orange and yellow colors. In 1993, Japanese Shuji Nakamura developed the first brilliant blue LED and a very efficient LED in the green spectrum range (InGaN diode). After a while, he also designed a white LED. He was given the Nobel Prize in 2014 for his contribution in the development of white LEDs that opened the path for the solid state light (SSL) to be used for illumination purposes in place of incandescent, fluorescent and halogen lamps. The first LED with white light from luminescence conversion was introduced and launched in the market two years later. The first light emitting diodes with 100 lumens per watt were produced in 2006. This effectiveness can be surpassed only by gas discharge lamps. In 2010, LEDs in certain colors with a huge luminous efficacy of 250 lumens per watt were already being developed under laboratory conditions. Progress goes on to proceed. Today, further development for Organic LED (OLED) is considered as the technology of the future [14].



**Figure 7** Evolution of LED technology from the 1960s to the 2000s [15]

### 2.3. Fundamental Principle of a LED (Light Emitting Diode)

An LED is basically a PN junction diode, which is simply formed when n-type and p-type semiconductor materials make a junction. The semiconductor materials are chosen as direct-bandgap semiconductors for the LEDs. When the LED is forward biased and a forward current passes, light is emitted from the device.

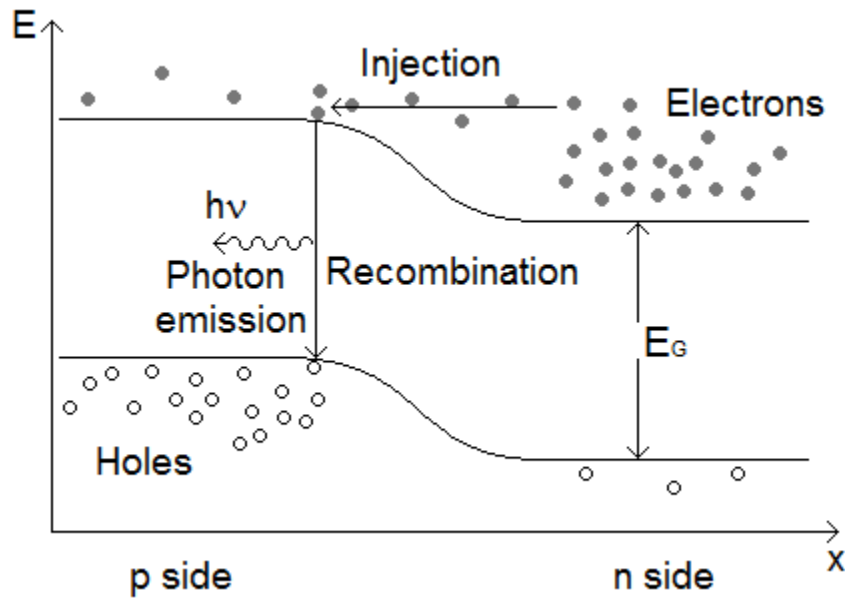


**Figure 8** A diode with forward bias applied, leading to current flow and the injection of minority carriers into the majority carrier regions [16]

The energy bandgap of the semiconductor material determines the frequency ( $\nu$ ), i.e., the color, and the energy of the photon emitted,

$$E = h \times \nu \quad (2.3)$$

Recent developments in material sciences and manufacturing technologies have made obtaining LEDs emitting light in the spectrum ranging from infrared (IR) to ultraviolet (UV) wavelengths possible. The photon generated by the LED is due to the recombination of an electron having energy in the conduction band with a hole in the valence band of the semiconductor. The recombined electron and hole are called an electron-hole pair (EHP). When a free electron in the semiconductor material (an electron in the conduction band) becomes bound to an atom fixed in the material (filling a hole, becoming a bound electron in the valence band), the energy lost by the free electron is generally equal to the energy bandgap of the material in a direct bandgap semiconductor. This energy is transmitted mostly as a photon.



**Figure 9** Energy levels of LED against physical distance [16]

This mechanism of generating light is called electroluminescence. In indirect bandgap semiconductors, however, the energy lost by the recombining EHP is mostly given off as heat to the material. When there is no extrinsic excitation to the LED, that is when the LED is in thermal equilibrium, some EHPs recombine randomly and ultimately the number of photons generated is negligible. However, when too many EHPs are injected into the LED by an outside excitation, applied forward-bias voltage, the rate of recombination of EHPs and therefore, the rate of generation of photons increases enormously and the intensity of the light emitted from the LED becomes noticeable. There are many charge carriers, mainly free electrons (n) and holes (p) in the n- and p- regions of semiconductor, respectively, at room temperatures normally. When the LED is biased in the forward direction these free charge carriers will move into the opposite region under the influence of the electric field generated by the bias. The net charge transfer through the cross section in time generates a current from p to n-region, which is called the forward-current. The forward current carries the EHPs to the junction region of the LED oppositely from both sides, where they meet, recombine and generate the photons. If a constant forward current passes photons are generated in a constant rate in an LED. Since the photons emitted by the LED are of generally a constant energy approximately equal to the bandgap of the semiconductor, the spectrum of the light generated by a LED occupies a narrow range of about 20 nm on the wavelength axis. Therefore, their colors are considerably pure [17] [18] [19] [20]. Not all of the recombining carriers give off their energy as photons even in the direct

bandgap semiconductors. Some of the energy lost by recombination is transferred to the semiconductor as heat. Also, not all of the photons generated in the diode can find a way to get out of the semiconductor material and is transmitted. A quantum efficiency that relates the number of the transmitted photons and the number of generated photons,  $\eta_{ex}$ , is given as,

$$\eta_e = \frac{\Phi_o}{\Phi} \quad (2.4)$$

where  $\Phi_o$  is the output photon flux (number of photons transmitted per second), and  $\Phi$  is the internal photon flux (number of photons generated per second). The forward current  $I_f$ ,

$$I_f = n \times q \times v \times A \quad (2.5)$$

where  $n$  is the number of charge carriers in a unit volume,  $q$  is the unit charge,  $v$  is the velocity of carriers, and  $A$  is the cross sectional area of the junction. The number of photons generated by the recombining EHPs in a second is given as,

$$\Phi = \eta_i \times N \quad (2.6)$$

where  $\eta_i$  is the internal efficiency of recombining carriers to generate photons,  $N$  is the number of carriers recombining in a second,

$$N = \frac{I_f}{q} \quad (2.7)$$

Then,

$$\Phi = \frac{\eta_i \times I_f}{q} \quad (2.8)$$

is obtained. Actually  $I_f/q$  is the injected photon flux by the forward current. The output, i.e., transmitted, photon flux is then

$$\Phi_o = \frac{\eta_{ex} \times I_f}{q} \quad (2.9)$$

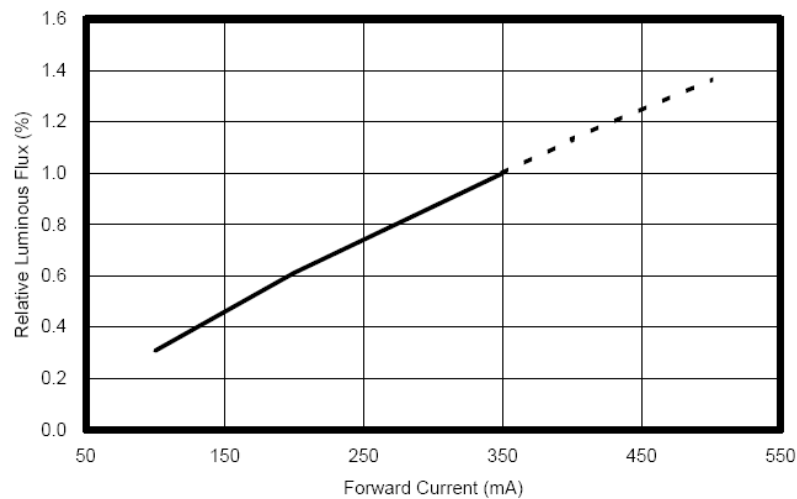
$\eta_{ex}$  is a single quantum efficiency, the external efficiency, that accommodates both of the processes, i.e.,  $\eta_{ex} = \eta_e \times \eta_i$  which can reach 50% [20]. The LED output optical



power,  $P_o$ , is then obtained by the product of the photon flux and the photon energy  $h \times \nu$ ,

$$P_o = h \times \nu \times \Phi_0 = \eta_{ex} \times h \times \nu \times \frac{I_f}{q} \quad (2.10)$$

The optical output power is directly proportional to the forward current. We control the optical output power of a LED by controlling its forward current. Fig. 10 shows the relative luminous flux versus forward current in a power LED (actually the figure is taken from the manufacturer's datasheet of the LEDs we use in this work) which confirms (eq. 2.10) to a great extent [21]. The optical output power would not increase with the increase of forward current indefinitely; as the forward current increases, beyond a certain level the efficiency of the LED decreases. The luminous flux is the part of the optical power (or sometimes called as the radiant power), which is composed of the photons of the wavelengths within the visible range of the human's eye only. LEDs also have a very quick response time (about 20 ns) and instantaneously reach full light output [19].



**Figure 10** An LED's luminous flux versus forward current [22]

## **2.4. State of the Art LED Technology**

LEDs are perfect solution compared to the other lighting technologies to consider the developments and future goals. Lots of users are impressed from limitless design possibilities based on a variety of color, compact dimensions and flexibility of the LEDs. This section introduces the development, the advantages and disadvantages of light emitting diodes.

Long lifetime is the one of the most important advantages of LEDs. They can go up to 100.000 hours of operation under the standard use conditions, but their lifetime is about 50.000 hours due to the internal chip temperature. Although LEDs are considered having longer life than incandescent and halogen lamps, lives of LEDs show a decrease depending on the other parameters used. The life of a LED differs depending on the parameters like working voltage, current, heat, the design of the luminaire used. LED lifetime is the time it takes when the LED intensity decreases to 70% of its intensity in the first use. That is, when the light intensity emitted by the LED decreases 70% as of the day of first use, it can be said that the life of LED is over. The light is generated in nanoseconds by an LEDs when it is turned on, i.e., the forward bias is applied, which is quite shorter compared to the time of turning the other lamps on and off. The LEDs are used for communication purposes as well. This communication infrastructure is called Visible Light Communication, which is a new pattern for optical wireless technology to create a unique connectivity within a localized data-centric environment. The increasing demand for higher bandwidths, faster and more secure data transmission and also environmental and undoubtedly human friendly technology announces the good news of the start of a major shift in wireless technology, a shift from RF to optical technologies [22].

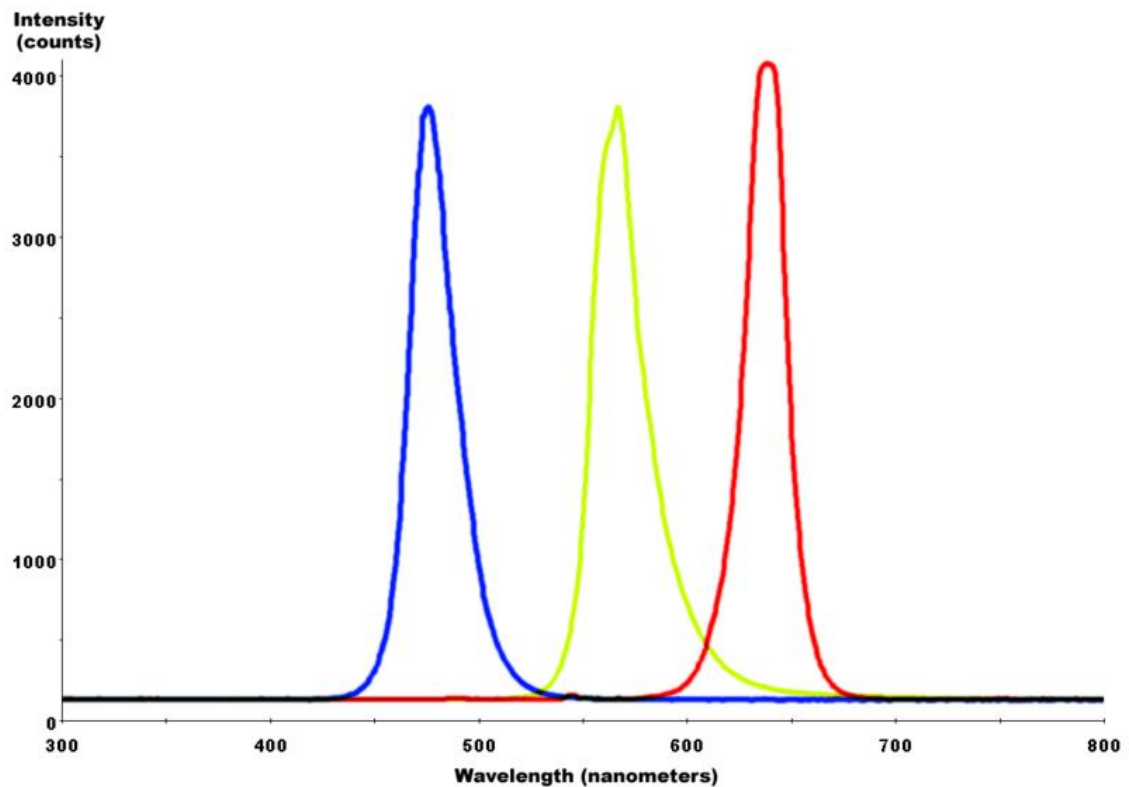
Since LEDs have small sizes and emit directional light, they allow the design of compact lighting. Today, the size of LED chips become quite small. High-brightness LEDs (HBLEDs) of 5mm and surface-mounted polymer LEDs (PLEDs) with 3 mm package are among the most common ones [23].



**Figure 11**LED Types [24]

LEDs can emit light throughout a narrow wavelength region in many regions of the visible area. Obtaining the LED emitting blue light by Shuji Nakamura in 1993 triggered a revolutionary change in the illumination industry by generating white light with LEDs possible. When the blue light of the LED falls on a phosphor it creates secondary photons by the phosphor. The secondary photons emitted by the phosphor are of various wavelengths in the visible range and they are seen as day light by our eyes. By this way, LEDs emitting white light started to be produced and used in lighting applications. Another way of obtaining white light is to blend red, green and blue lights from the LEDs. With the blend of these three colors, almost all the colors that are visible to us can be obtained. In the lighting applications where colorful light is desired to have, in the colors of television and the other visual indicators, the colorful lights are generated with the proper blend of these three basic colors (RGB).

The colors of the light of the LEDs are determined with the selected material. For example, while a GaAs LED emits infrared (IR) light, an AlGaAs LED emits red, a GaN LED emits green, an InGaN LED emits blue light.



**Figure 12** Spectral change of the light intensities of LEDs depending on the wavelength (for blue, green and red LEDs) [25]

In the recent years, both the color range of the LEDs and the power (flux) of the light emitted by the LEDs have increased. Today, the LEDs which can produce photometric power of 130 lumens per optical watt can be produced. This optical power level reached by the LEDs has allowed them to be used in even making projectors that can create powerful lighting. The light emitted by the LEDs is not composed of the photons that are straight in one direction. The photons emitted by the LED are diffused around and there is not a certain phase relation among these photons. That's why they don't create a light beam directed to a certain direction like a laser. However this phase diffused photons from the LEDs can be directed to one direction by being gathered through non-coherent light objectives. Thus, a beam with a certain direction can be obtained using optical systems. It is possible to make the lamps having different light effects with LEDs thanks to the use of different reflectors, LED combinations and lenses.

The other commonly used light sources are incandescent lamps and fluorescent lamps as known. Incandescent lamps are black body emitters. When a metal wire is heated

with electric current, it becomes incandescent. In fluorescent lamp on the other hand, the photons emitted in ultraviolet spectrum by a gas discharged with electric voltage are converted into day light by the phosphor coated on a glass tube. Incandescent and fluorescent lamps emit typical white light (day light). The white light comprises photons in all wavelengths in the visible region.

Today, LED lamps take the place of incandescent and fluorescent lamps. Compared to the other lamps LEDs are:

- more efficient, they produce more optical power output from the electrical power input,
- having longer lifetime,
- not fragile and not sensitive for shaking, they are more robust,
- producing in any desired light color, they can produce light in all the visible spectrum,
- not including any substance harmful to the environment, they are more environmental friendly,
- and having a short reaction time, they are turned on and off faster.

Table 1 compares the light sources in relation to the effectiveness and lifetime values. Effectiveness is the factor showing the efficiency of converting electrical power to light. Unit of effectiveness is lumen/watt.

**Table 1** Comparison of Light Sources [26]

<b>LIGHT TYPE</b>	<b>EFFICACY (LM/W)</b>	<b>USABLE LIGHT (LM/W)</b>	<b>LIFETIME (HOURS)</b>
Incandescent	17	10-17	3.000
Halogen	20	12-20	10.000
T12 fluorescent	60	45-50	20.000
Metal Halide	70	<40	<15.000
Best white LED in 2006	71	71	>50.000
T8 fluorescent	74	55-60	20.000
High-pressure sodium	91	<50	<24.000
Best LED in research	92	92	TBD
T5 fluorescent	100	100	20.000
Low-pressure sodium	120	120	18.000
Record LED - research	138	138	TBD

Besides the advantages, LEDs have many properties that can be considered as disadvantage. The first one of these is the startup cost necessary to use the LEDs. Since the startup cost is higher, when LED is used in an application the return on investment (ROI) takes longer. Although lifetime of LEDs is about 100.000 hours, the life of the driver circuit which is necessary for them to work is generally less than 50.000 hours. That's why even though the LEDs are operated properly, the LED lamps containing LEDs and LED Drivers can only operate for the half of its life. When it is not driven with the right driver circuit, their operation life gets shorter.

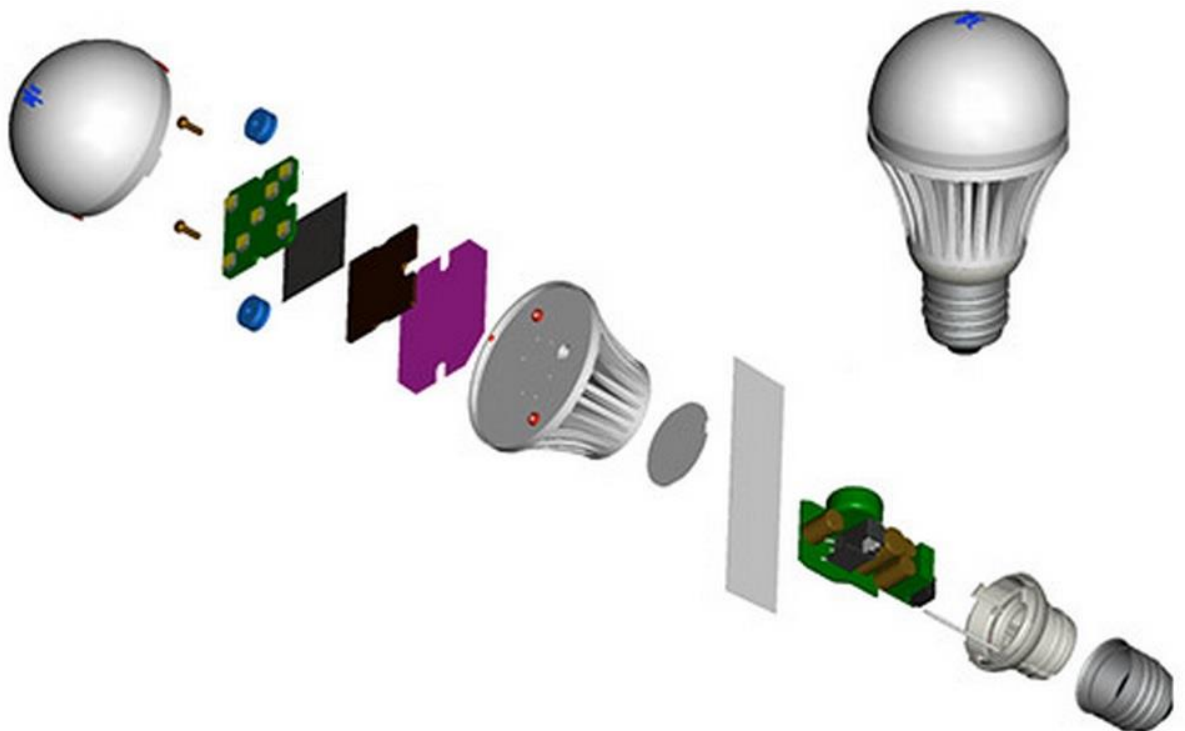
When the LEDs are not operated with the proper driver circuit, they get overheated, and the higher junction temperatures the shorter lifetimes.

One of the other problems of LEDs is the *dark secret*, which is the decrease in the effectiveness of light output of LEDs when current of LEDs increase. By this time

nobody has been able to solve the problem of fading, and some people and companies are working to describe this problem, its impacts and consequences [27].

## 2.5. A Light System's Efficiency

According to the standard “ANSI/IESNA RP-16 addendum”, the terminology in solid state lighting systems (SSL), which is made with the use of LED, is standardized. Accordingly, a **LED package** is composed when more than one LED chips (die) are brought together; a **LED module or an LED array** is created when more than one LED packages are combined on a printed circuit board; and a **lighting unit** that is created when the light sources with LED are connected to a **luminaire** together with the optical systems, a cooler and a power source is called **integrated LED lamps** [28].



**Figure 13** Components of an integrated LED lamp [28]

For a lighting device to run efficiently, it must satisfy the issues of optical efficiency, light-source efficiency, body and cooler efficiency and driver efficiency. Efficacy is a term used to express the ratio of the luminous flux generated to the electrical power applied to the LED (Lumen/Watt). When we are talking about a lamp, or more

generally a luminaire for lighting purposes, which can comprise many LEDs connected as parallel or as series, a driver, an optical system, a cooler, we prefer using the term efficiency. Efficiency is defined as the ratio of the radiant flux generated to the electrical power applied to the LED (Watt/Watt).

### **2.5.1. Light Source Efficiency**

Unlike LEDs, in the traditional light sources (incandescent lamp, halogen lamp) a major part of the energy is converted to heat. Owing to this feature, the devices with LEDs can emit more light than the traditional lighting luminaires although LEDs use lower energy. Selection of the LEDs with high light flux and color return and low thermal resistance will increase the efficiency.

### **2.5.1. Driver Efficiency**

During the operation of LEDs, heat forms in their chips and with the generation of this heat, a change occurs in the inner resistance of LED. That's why LED draws more current when it is heated. The LEDs getting more current gets overheated as a result. With continuity of this cycle, recommended maximum operational temperature and power consumption for LEDs can be exceeded and thermal runaway may occur, and this causes the LEDs to break down. In order to avoid this, properly designed LED drivers are needed. The difference of these LED drivers from the power supplies we are familiar with is that they provide constant current at a constant voltage instead of constant voltage only. When the integrated LED lamps are equipped with the properly designed drivers and ballasts of high quality that have thermal protection and short circuit protection, the reliability of the system will increase and the operational costs will decrease.

### **2.5.2. Optical Efficiency**

In order to direct the light coming out of its source to a surface, lenses called reflector or secondary optics are needed. In the lightings made with traditional light sources and reflectors, maximum 80% of the total light flux from the light source can be directed



to the object desired to be illuminated. LEDs emit light to one direction with a large angle. When proper and high quality lenses are used, it is possible to obtain 90% percent light with LEDs in the given region.

### **2.5.3. Thermal Efficiency**

Particularly if LEDs are operated in a warmer environment than their ideal operation temperature, both light amount emitted and the life of LED will decrease. That's why, one of the factors necessary for the system efficiency in the lighting devices with LED is the design of the coolers. The coolers must be designed at the very beginning in the most proper way to the need. In the integrated LED lamps the heat that occurs in the chip of the LEDs, in the junction of the diode, must be removed. For this, thermal efficiency between the LED junction and the ambient must be high, and the thermal resistance should be low. Four main factors affecting the thermal efficiency are the type of the LED, the LED Driver, the PCB (printed circuit board), and the thermal paste (a paste to provide a better cooling enabling a more efficient heat exchange between the metals and the cooler). A high thermal conductivity of these four factors provides the total system thermal efficiency of the device.

### **2.6. LED Drivers**

Light power emitted by the LEDs depends on the extent of the current which flows in the direction of conduction through pn junction diode up to a certain limit. Even though the forward voltage applied,  $V_f$ , formed on the tips of a diode in the direction of conduction increases very little when the diode current increases, this change remains in a tolerance of nearly 10%. Even though the production parameters, material properties, environment variables are tried to be held constant among millions of LEDs produced in the same type, some differences will definitely occur. The parameters such as efficacies, color qualities, and forward conduction voltages of the LEDs that are produced in the same batch show differences in certain statistical distribution. LEDs are normally used as arrays or module in a lighting application, such as in an integrated LED lamp. LEDs are connected in series and / or in parallel within these packages and

arrays. That's why, conduction voltages and other parameters of the LEDs with the same type and serial numbers from the production line must be the same as much as possible. Color quality of each LED from the same production will not be the same as well. The effects of these differences on the integrated LED lamps must be removed and the properties of LEDs which are on the market with a type or a serial number must be the same as much as possible. The differences from the LED packages are tried to be resolved mainly with the driver circuits [29].

In order to form an integrated LED lamp (an SSL lighting unit) that has a certain light power and distribution, more than one LED must be connected in parallel and/or serial. In a circuit, while the same amount of current flows ( $I_f$ ) through k LEDs, the total of the conduction voltages ( $k \times V_f$ ) formed on their tips must be provided by the driver circuit. In this case, the power to be provided by the Driver Circuit :

$$P = k \times V_f \times I_f \quad (2.11)$$

In the parallel LED arrays composed of k parallel LEDs, the voltage on the tips of the LEDs are determined by the LED having the lowest  $V_f$  value and the total of the currents flowing through each parallel LED ( $k \times I_f$ ) must be given by the Driver Circuit. In this case the power to be provided is determined by Eq. 2.11 as well [29].

Lifespan of the LEDs decreases because of the high junction temperature. In such a case, required measurement is carried out and this decrease is calculated; related measures are taken for the driver control circuits and employment times of the LEDs are recorded and the decreases in the light power are neutralized with a convenient increase in  $I_f$  current in the way determined before. Likewise, decays in the color quality seen in time can be corrected to a certain extent by dealing with the forward currents of the LEDs [29].

Since the LED is a semiconductor diode, they can be switched on and off fast. The extent of the frequencies determined by the switching speed which is limited with the junction capacitor (Cd) arising from the size of the area in the junction region and physical properties of the semi-conductor material. These switching speeds can reach up to MHz levels. Since the human eye cannot perceive the changes more than 25 per

second (25 Hz), our eye will perceive this as a continuous light rather than a flashing light if LEDs are switched faster than this rate [29].

$$DutyCycle = \frac{t_{on}}{T} \quad (2.12)$$

Here  $t_{on}$  is the time when LED is on and T is the period of switching time. By changing duty cycle of the current in the direction of conduction, it is possible to control (dimming) average light power based on the average of the current. Driver circuits can fulfill this control as well. When operated in such a way by switching, overheating of the LED is avoided to an extent and as a result its cooling need is decreased and the life of LED is extended. Of course, in this case, especially in the lighting applications for the automotive applications, it is necessary to take required measures on the issues of electromagnetic interference (EMI) and electromagnetic coupling (EMC) that occur as a result of high frequency operation of the integrated LED lamp [29].

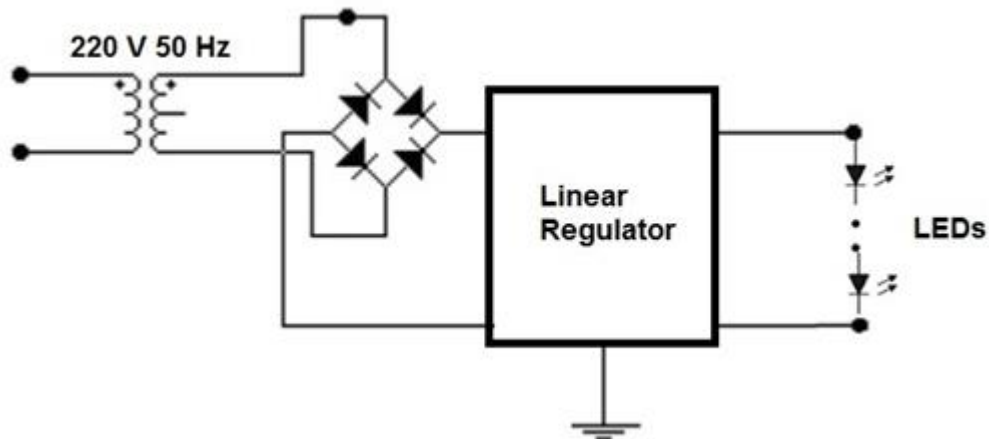
LEDs can be connected to the line voltage without any driver, in other words directly. In this case, they emit light when they are in conduction (in the half-period of the line voltage) and in the other half-period they don't emit light since they are in reverse bias. Line voltage is 50 Hz in Europe and our country and 60 Hz in the USA, so our eyes cannot notice that the LEDs flash 50 or 60 times per second. The important thing here is to take the measures to avoid any harm to the diodes by the line voltage of 220 V<sub>eff</sub>, or having the peak value of 311V between phase and neutral. This is arranged by connecting the proper number of LEDs in series and / or converting the remaining voltage on a proper resistance to heat. The intensity of the current is also limited by using a serial resistance over which the diode current will flow. Such an SSL lighting unit with LED is naturally not suitable in terms of energy efficiency. Also, LEDs cannot be driven with ideal conduction currents here because of the sinusoidal current change, and the efficiency is very low due to the power loss on the resistance [29].

LED Drivers are the electronic circuits which generally drive the LEDs in one direction, control the average current intensity as well and can enable constant voltage values necessary for the LED package. LED driver circuits are divided into two main groups [29]:

- Linear Driver Circuits,
- Switched-Mode Driver Circuits, or Switch Mode Power Supply (SMPS).

### 2.6.1. Linear Driver Circuits

These circuits are the driver circuits where the alternating voltage in the power line with 50 Hz frequency of the peak value  $V_p$  of 311 V is reduced to a required peak value by means of a transformer. The sinusoidal voltage of 50 Hz and of a proper peak value in the secondary of the transformer being a sinusoidal signal does not have an average value. This signal is then rectified by a diode bridge circuit. The voltage at the output of the bridge has a finite average value, that is, a direct current (DC) signal. A full-wave rectified sinusoidal signal's period is divided by two, i.e., its frequency is doubled and becomes 100 Hz. Although it has an average value of about  $0.636V_p$ , this signal still contains a large ripple (a change in the voltage value in a period) which causes the voltage level to change from zero up to 311 V. This ripple in the voltage causes ripple in the current also when applied to a LED circuit. Such a ripple of 100 Hz frequency creates a flickering effect and it causes the disturbance on the people. As shown in (1.9), a change in LED current will translate a change in the intensity of the light generated, although not perceived, this is not desired because it will disturb the people when it is used for illumination and, besides, it will reduce the lifetime of the LED as well. To reduce the ripple to the desired level and obtain almost an ideal DC voltage (a constant voltage, no change in voltage value in time) a proper regulator is used. The regulator generally employs an active device such as a transistor, and the transistor is used in a way to change the voltage level between its two terminals, one being connected to the input signal and the other connected to the load. Since this transistor is operated in its linear region to provide the regulation, hence the name "linear regulator" is used. A transistor operates in linear region behaves essentially a variable resistor, whose resistance is controlled by the base current. Increasing base current decreases the transistor's resistance and vice versa. The same effect is obtained for a Field Effect Transistor (FET) with the change of the gate-to-source voltage.



**Figure 14** A LED Driver Circuit with a linear regulator

The regulator provides the line and the load regulation at the same time. The line regulation refers to the regulation to prevent the effects of the input signal change at the output, the load regulation refers to the regulation to prevent the effects of the load change. The Linear Driver is the overall circuit consisting of the transformer, the diode bridge and the linear regulator. In the Linear Drivers, output voltage is always lower than input voltage. This type of driver is called “the buck driver”. In the linear drivers the voltage difference between the peak value of the voltage (input voltage) and the voltage required on the LEDs (output voltage) falls on the linear regulator. Generally, a little more than the total current flowing over the LED array is consumed on the other circuit components ( transformer, bridge circuits with diode, power transistor providing regulation) and the power loss of the Linear Driver is equal to the multiplication of the difference voltage between the voltage of input and the voltage applied on LEDs and this total current. This loss, dissipated as heat, is the main reason of the decrease in the efficiency of Linear Driver. The driver’s power efficiency is defined as

$$Driver\ Power\ Efficiency = \left( \frac{Output\ Power}{Input\ Power} \right) \times 100 \quad (2.13)$$

$$Output\ Power = V_o \times I_o \quad (2.14)$$

where  $V_o$  is the output voltage, and  $I_o$  is the output current,

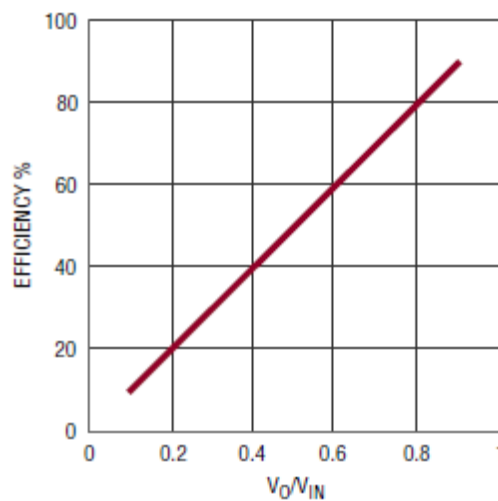
$$Input\ Power = V_{in} \times I_{in} = V_o \times I_o + (V_{in} - V_o) \times I_o \quad (2.15)$$

$$\text{Driver Power Efficiency} = V_o \times I_o / [(V_{in} - V_o) \times I_o + V_o \times I_o] = V_o / V_{in} \quad (2.16)$$

The power lost in the linear regulator is =

$$(V_{in} - V_o) \times I_o \quad (2.17)$$

The efficiency of the linear regulator, therefore, decreases as the voltage difference between input and output increases. The efficiency of a linear regulator as a function of  $V_{in} / V_o$  is given in Fig. 15.

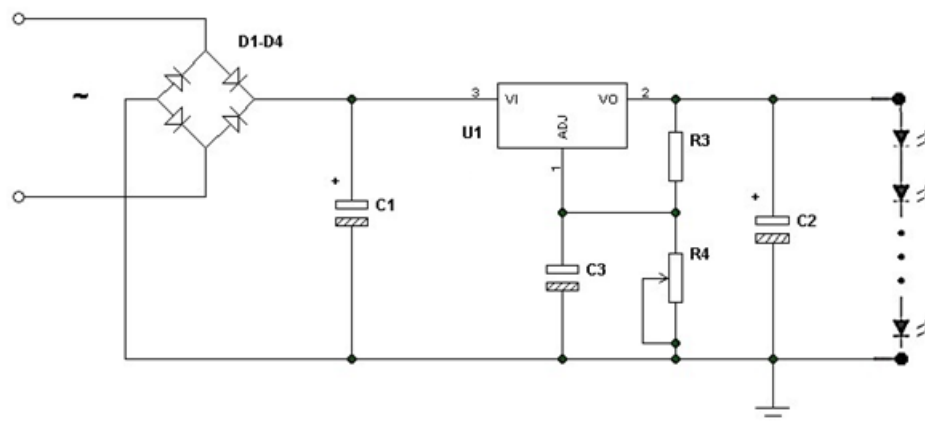


**Figure 15** The efficiency versus  $V_o/V_{in}$  of a linear regulator [30]

This efficiency of linear regulators in practical circuits cannot exceed 80%. This power lost is dissipated as heat and it heats mainly the regulator circuit that provides the voltage regulation and the current of the LEDs. This heat most frequently should be taken away from the regulator and dissipated to the environment by a cooling system (a cooler). The more difference between the input and output voltages, the higher the power lost in the regulator, and the less the efficiency of the Linear LED Driver. When the transformer and cooling system are used in these drivers, they also occupy a great deal of volume (footprint) and they become too heavy and expensive as well. Also, the circuit components cause failures in time due to this continuous heating. When the driver breaks down, the integrated LED lamp unit containing the driver also fails, so this lamp should be either replaced with a new one or repaired. This causes a material and labour cost which sometimes becomes too high to be tolerated especially for a

supermarket for example, which may have thousand of light units. This situation prevents LEDs to get benefit from their potential life-time (up to 100.000 hours), and to make use of their higher efficacies, and therefore, it reduces the advantage of the LEDs to a certain extent. In such driver circuits, the current flowing over the LEDs can be switched on and off by controlling the duty cycle in a certain frequency with a control circuit. Thus, dimming can be performed with linear LED drivers.

Although they have lower efficiencies relative to the switching mode power supplies (SMPS), the Linear Drivers are still preferred in some applications because the linear regulators are introduced as integrated circuits (ICs) packages that are relatively inexpensive and so common, and also they are very easy to use. For example, one needs only two capacitors at the input and output of a 78XX type regulators, and maybe two more resistors to arrange the feedback in an LT1083 in Fig. 16 and they provide the regulation required. Their other advantage is that they do not need inductors to store the energy. Since their ripple frequencies are very low (100 Hz) and their ripple voltage levels can be made very small (less than 25  $\mu$ Vrms) they are very good in terms of electromagnetic interferences (EMIs).



**Figure 16** A Linear LED Driver Circuit

### 2.6.2. Switched-Mode Driver Circuits

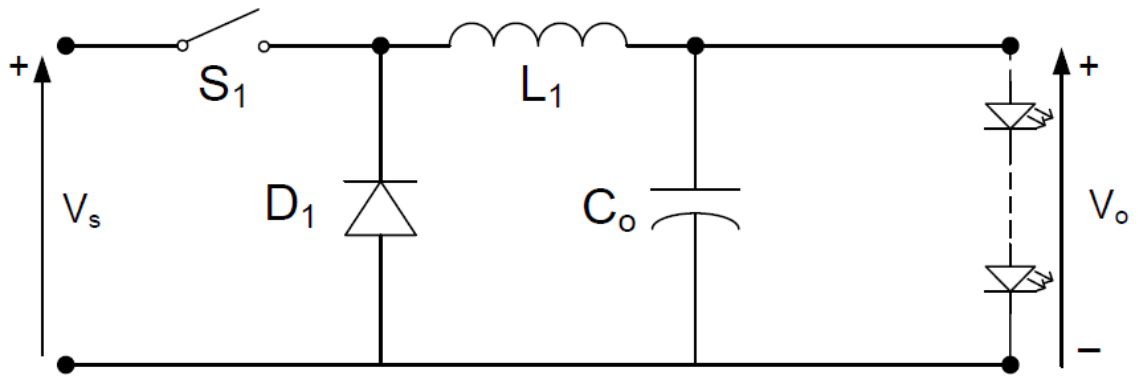
Switched-Mode Driver Circuits generally don't need the use of a transformer and rectifier, when rectification is performed by some switching circuits as well. In these drivers, it is also possible to produce the output voltages lower (buck) or even higher (boost) than the input voltages or to have both lower and higher output voltages than

input voltage at the same time, and the output voltage with inverse polarization. Also, they occupy less space and they are lighter than the Linear Drivers in general. Their efficiency is higher than the Linear Drivers as well. The efficiency of such circuits starts from 85% and may rise up to 98%. In these drivers, MOSFET type of power transistors for switching and inductors (L) and capacitors (C) are used in order to store the energy temporarily and to transfer it to the LEDs. In addition, since the current flowing on the LEDs are not constant but rather changing on and off at a certain frequency, heating of the LEDs is lower compared to the other driver circuits. The change in current when it is switched on and off is not as disturbing as it is in the linear regulator because here the change occurs at frequencies generally much higher levels than 100 Hz. Such a very quick change in intensity of the light does not cause the flickering effect and it does not disturb the human eye. In these circuits, dimming can be performed by changing the rate of duty cycle with the pulse width modulation (PWM) technique. Light power is directly proportional to the LED forward current average level thus the light power emitted by the lamp can be controlled by arranging the duty cycle of the voltage applied to the LEDs.

The name “switching” comes from the fact that the transistors used in switching (nonlinear) modes in these type of drivers. The higher efficiency is obtained because when the transistor switched to on state it draws the current but has a very low voltage drop between the two terminals, hence, the power it consumes is very small. When the transistor is switched to off state, this time it has all the voltage across the terminals but draws essentially no current, and therefore, it consumes again very small power. For example, if we use a Linear Driver to deliver a 3.3V at the output from a voltage of 12V at the input we can obtain 27.5% maximum efficiency. However, a switching mode driver can provide this with more than 90% efficiency [30]. The switching mode driver would occupy also a much less space than the linear driver.

In Figs.17-21, principle circuit schematics of three types of switched mode drivers are shown.





**Figure 17** A Buck Type Switching Mode Driver

In this circuit, output voltage is lower than the input voltage ( $V_{out} < V_{in}$ ). S1 denotes a switch. S1 in reality is generally a metal-oxide semiconductor field effect transistor (MOSFET). When the MOSFET S1 is switched on with a switching signal applied to the input (when it is driven deep into the saturation mode), a constant voltage ( $V_{in} - V_{out}$ ) is applied to the inductor ( $L$ ). The diode in this cycle is reverse biased and it is open circuited. In this cycle, the current on the  $L$  increases linearly. An energy of  $(1/2) L \times I^2$  is stored in  $L$ . When the MOSFET is switched off (when it is driven into the cut-off mode) on the other hand,  $L$  discharges the energy stored to the ground through the capacitor ( $C$ ). The flyback diode prevents the current on  $L$  to flow in the reverse way. The output voltage  $V_o$  is applied to the LEDs.  $V_o$  is generated by the capacitor voltage when it is charged when the MOSFET is off, and discharged when the MOSFET is off. Since the capacitor charges through  $L$  and the series resistance of MOSFET, which is very small (about  $20\text{ m}\Omega$ ) it takes very short time to charge, and since it discharges through the LEDs it takes again the short time but a little bit longer than the charging cycle. The output voltage  $V_o$  stays considerably constant at a value set by mainly the duty cycle ( $D$ ) of the output voltage.

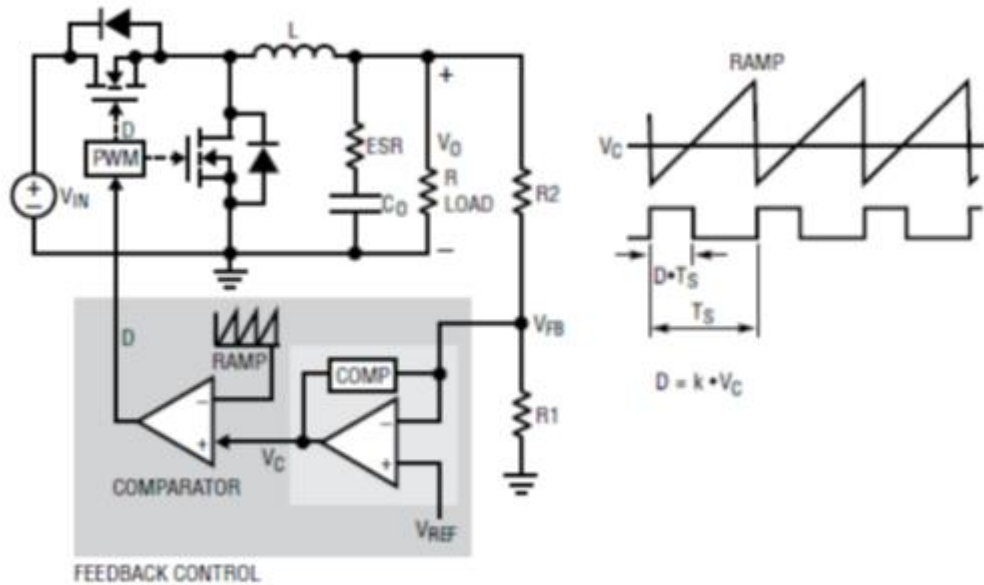
$$V_o = D \times V_{in} \quad (2.18)$$

By setting up the value of the duty cycle ( $D$ ) the desired output voltage can be obtained from the input voltage.

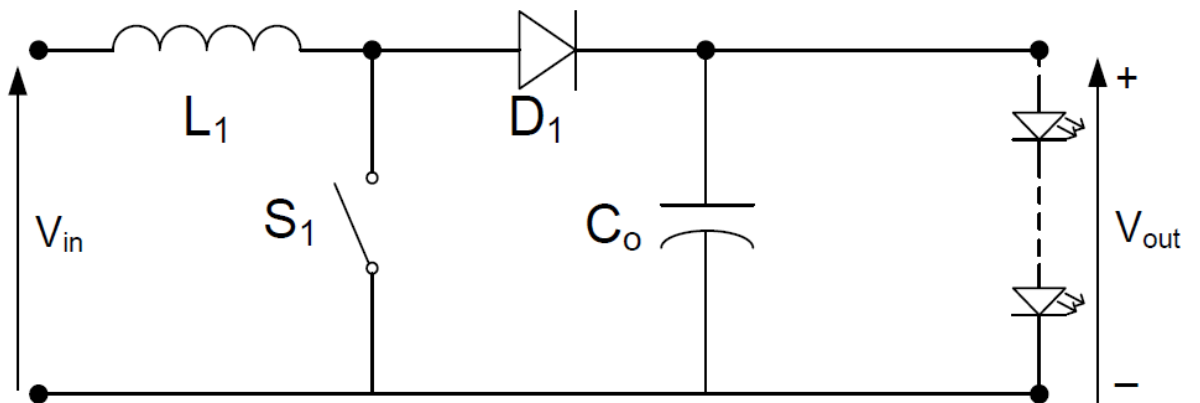
Generally very high switching frequencies can be used (250 kHz to 2 MHz) to obtain the operation. The higher the frequencies the smaller the  $L$  and  $C$  sizes. However, increasing the frequency increases the Alternating Current (AC) loss, and it causes the electromagnetic interference (EMI).

Fig. 17 shows a buck type switching mode driver, which has a feedback loop to keep the output voltage constant. This type of feedback control is called voltage-controlled because the output voltage is measured and compared with a reference voltage. When the output voltage increases the  $V_{FB}$  across  $R_1$  increases. The increase in the inverting input of the op-amp comparator decreases the output voltage ( $V_c$ ) of the op-amp. A ramp signal is applied to the inverting input of the second op-amp and this is compared with the  $V_c$  from the first op-amp. As shown in the set of the figure, when the ramp signal is higher than  $V_c$  the output of the second op-amp is pulled up to the positive supply voltage. When the ramp voltage becomes lower than  $V_c$ , this time the output of the second op-amp pulls down to the lower power supply voltage applied to the op-amp. So, as  $V_c$  gets smaller the time for the second op-amp's output voltage being in the high-state increases, that is, the duty cycle ( $D = t_{on} / T_s$ ) increases. When  $V_c$  increases the duty cycle decreases, and this decreases the on-time of the MOSFET, and hence, less energy is transferred to the output and the output voltage becomes lower again. The second MOSFET in the figure is used instead of a flyback diode, since the flyback diodes cause higher power losses than a MOSFET due to their higher resistance in forward bias condition than the MOSFETs' lower channel resistances.

The circuit in the feedback loop shows also how the pulse width modulation (PWM) with a control of duty cycle ( $D$ ) is generated. The output voltage is  $V_o = D \times V_{in}$ .

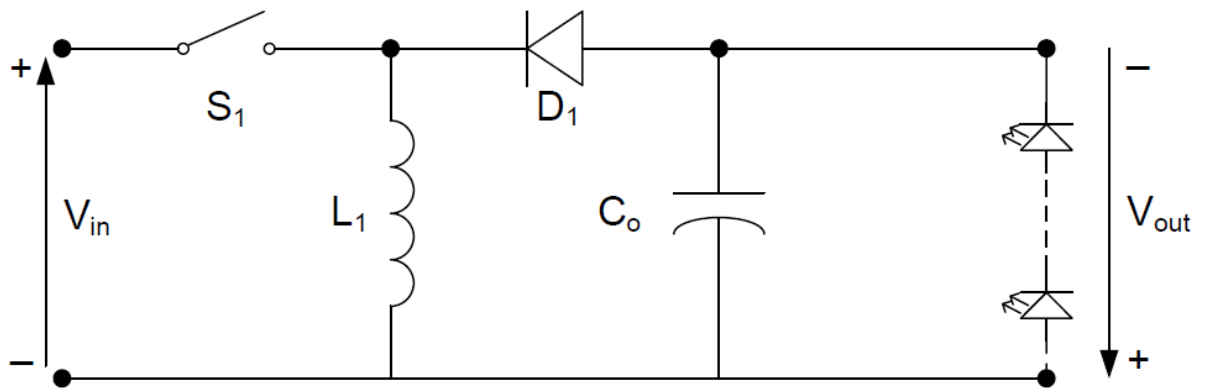


**Figure 18** A Boost Type Switching Mode Driver with a voltage-control [30]



**Figure 19** A Boost Type Switching Mode Driver

In the boost type of switched mode driver circuit given in Fig. 19, when MOSFET is on, the current flows through  $L$  to the ground. The voltage across  $L$  is  $V_{in}$ , and the current in  $L$  in this cycle increases linearly and energy is stored within  $L$ . When MOSFET is switched off, this time the energy stored in  $L$  is transferred to the capacitor at the output through the flyback diode, which is forward-biased and short circuited in this cycle. The capacitor is discharged through the LEDs in the first cycle, and it is charged in the second cycle by the current from the inductor  $L$ . When MOSFET is off, the input voltage plus the voltage developed across the inductor is charged into the capacitor. This voltage is higher than the input voltage, and thus, a higher output voltage than input voltage is obtained.

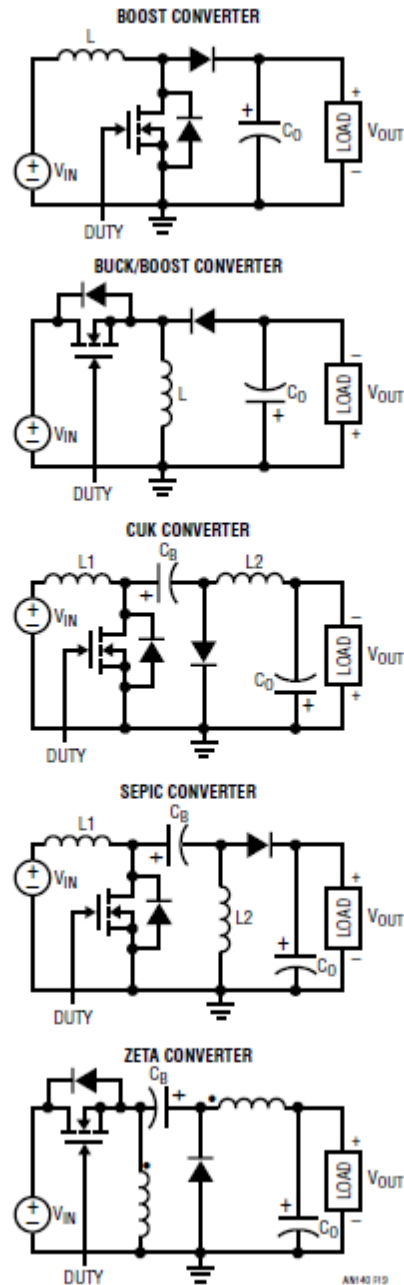


**Figure 20** A Buck Type Switching Mode Driver that produces a negative output voltage

Fig. 20 shows the principle circuitry for a Buck type switching mode driver, which can provide a negative output voltage from a positive input voltage. When the switch is turned on, the current flows through the inductor  $L$  to the ground. The current increases linearly because the inductor has a constant voltage between the two ends ( $V_{in}$ ) and energy is stored. In this cycle the diode is reverse-biased and no current flows to the capacitor. The capacitor in this cycle discharges through the LEDs. When the switch is turned off, the energy stored in the inductor is transferred through the flyback diode to the capacitor. In this cycle the capacitor is charged to a voltage in the reverse direction, i.e. the bottom plate has the higher potential.

In Figs. 17-20 we have a DC voltage at the input, and this voltage is made higher and lower in accordance with the requirement. A DC to DC conversion is made and such circuits are called generally as converters. Actually this DC input voltage is generally obtained by rectifying an alternating voltage, mostly the line voltage. The line voltage should be mostly stepped down by means of a transformer prior to the rectification. Stepping down and rectification can also be performed by switching without using the transformer and bridge rectifiers. We do not go into the details of this and assume that a DC voltage at the input is available.

In Fig.21 all types of the switch mode drivers are given.



**Figure 21** All Types of Switching Mode Drivers [30]

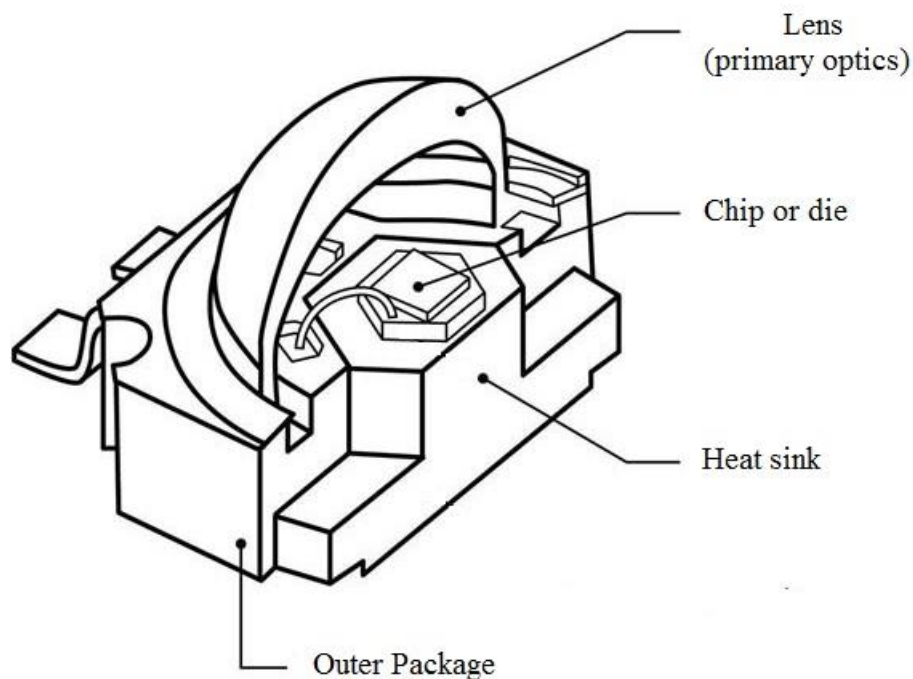
Switched-Mode Power Drivers always have higher efficiencies than Linear Drivers (generally higher than 90%), therefore they require smaller coolers. They occupy lower spaces (lower footprints) as well. Hence they have lower cost than Linear Drivers generally. Many integrated circuit (IC) switched-power drivers have been developed and produced by many various companies and these drivers released to the market commercially are selected and used based on the need for the LED SSL lighting units. Particularly since the lifetimes of electrolytic capacitors at the input and output

of switching mode drivers are much shorter than the lifetimes of LEDs, the life of a SSL lighting unit with LED is mainly determined by the LED Driver Circuit.

## 2.7. Optical Performance

In manufacturing the lighting devices with LED, depending on the application area, lens and reflectors can be used in order to direct the light to a certain object or region, create different light effects for different applications and to decrease the glare factor depending on the design features.

LEDs have the feature of having smaller shapes compared to their traditional competitors used in illumination applications. Incandescent filament lamps can emit light all around, that is 360 degree around the light source. However LEDs emit light only over 180 degree. LED package is basically composed of the following components as seen in Fig. 22: One or more semiconductor chips, a primary optic (lens, reflector), surrounding the die mounted on the heat radiating material.



**Figure 22** A Typical LED Package [31]

Traditional light sources are worked with lenses and optical accessories with metal, glass and acrylic reflectors that catch the multi directional light rays and reflect them to a desired direction.

Although the light rays from the LEDs are concentrated, the distribution is too large for many applications and the light intensities get smaller than the desired values due to the diffraction as the distance from the light source (LED) increases. Therefore; integrated LED lamps are combined with one or more secondary optics. Proper selection of optic depends on the application. The reflectors, Total Internal Reflection (TIR) optics and direct lighting which are common for LED MR16 shown in Fig. 23 have both advantages and disadvantages [32].



**Figure 23** MR16 LED Spot [32]

### **2.7.1. Reflectors**

Reflectors are more easily installed and less expensive compared to the total internal reflector (TIR) optics. Reflectors capture the light depending on their optical structures.

Reflecting films made of polymeric material can be applied on plastic substrates. These films are not conductive; they are highly reflective and sometimes superior to the aluminiums optically. Alternatively, reflective polymer can also be fitted specially within the reflectors in order to control the light and increase the surface brightness.



**Figure 24** Reflective films made of polymeric material [33]

#### **2.7.1.1. Aluminum Anodize Reflectors**

These reflectors are produced being exposed to chemical polishing (anodization) process after molded with the plastering method of highly pure aluminium [34].

#### **2.7.1.2. Vacuum Metalized Reflectors**

These reflectors are produced coating the reflector surfaces with aluminum or silver pieces which are turned into plasma in a vacuum cabin with a very low pressure levels [34].

#### **2.7.1.3. Differences between Vacuum Metalized Reflectors and Aluminum Anodize Reflectors**

The reflectors produced with the technique of vacuum metallization have approximately 3% more of brightness and efficiency as a result provided that all other conditions remain the same. This efficiency increases further when silver is used instead of aluminum [34].

With the vacuum metallization technique, it is possible to transfer the feature of reflectance not only on plating aluminium material but also on many other materials. Moreover, the reflectors can be produced from advanced plastic materials and later the



top of the reflectors can be coated with aluminium or silver materials. In such a case, by coating with the plastic material that has a good surface smoothness, more efficient reflectors can be achieved [34].

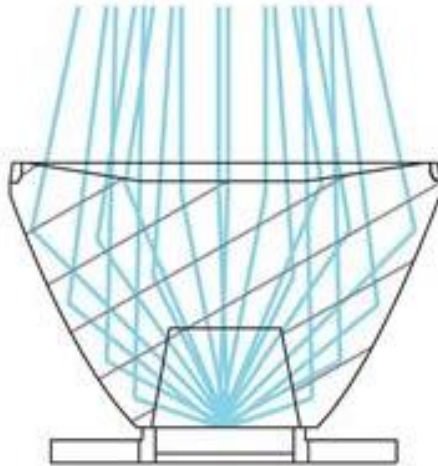
If the varnish is applied properly on the surface of vacuum metalized reflectors, their production error tolerances will be lower compared to the anodized reflectors [34].

#### **2.7.1.4. Total Internal Reflector (TIR) Optics**

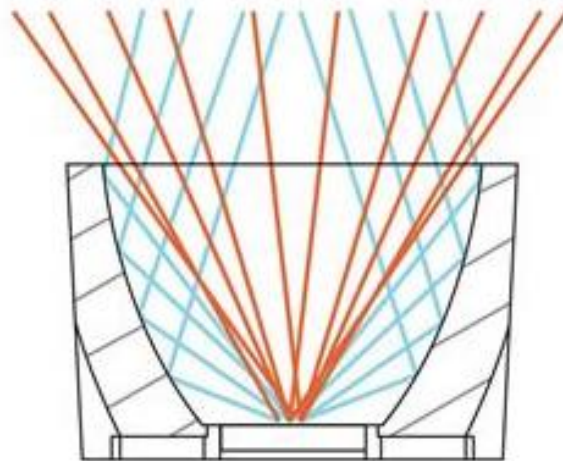
TIR optics or TIR lenses are composed of the refracting lenses that are fixed in a reflector and typically their optical activity is over 92% with a funnel shape. Lens direct the light in the center of the source to the reflector and the reflector sends it out with a controlled brightness [35].

TIR optics with polymer injection molds are created in a way of a certain flashing with various improvers. Nevertheless, injection molding limits the lens size and wall thickness (generally up to 0.5 inch). The larger the optic gets, the higher risk of shrinkage and deviation occurs. However, application of high temperature and pressure during the manufacturing decreases this risk [35].

Unlike the incandescent filament lamps which emit the light outward, LEDs heat their own bases and allow TIR optics to be easily fit on their domed peaks. Even though they are common in outdoor and industrial lighting, TIR optics are still more meaningful in indoor lighting applications. According to manufacturers, they are ideal for brightness control however they don't work for all applications.



**Figure 25** Total Internal Reflection Lens (TIR Lens) [35]



**Figure 26** Legacy Reflector [35]

TIR optics, which consist of refractive lens inside a reflector, capture and redirect more light emitted from a LED than conventional optics, such as a parabolic reflector.

Size ratio between the LEDs and the LED package determines the flashing angle for an optic. That's why narrower flashings need smaller light sources or larger optics. In spite of this, source sizes increase due to the need for higher brightness flux and convenience. LED manufacturers introduce modular, high output and chip-on board (COB) LED series on the market in order to draw the integrated LED lamp designers to their products. These series can provide 600 - 20.000 lumen outputs between 6W-

200W. COB LEDs are composed of multi dice that are combined on a ceramic package with a surface of one emission and wired to one electrical circuit. These dice are designed for a specific lumen output [36].

However it is more difficult to control the output in COB LEDs. Their sizes increase the prices of injection molding in proper optics. Also they don't give a good result in terms of matching the flat surfaces. The popularity of the LEDs with high density flux (HDF) increases day by day. They are composed of multi dice as well but each of them is smaller than the COB series and easier to interfere immediately. The dice on a domed surface are easily fitted on TIR optics and so they provide better output control [36].

Although, the physics rules limit the smaller versions of LED lamps that have narrower brightness angles, this process continues now to find a way. Manufacturers allow LED MR16 lamps to have 10 degrees of flashing distribution. Folded optic reflects the light emitted from just one LED package many times before it scatters out and makes the light gets close to the central axis of flashing indistinct. Thus, it creates a soft and well-defined flashing. This indicates that the larger diameter optic can be injection coated for the diameter ratio of 6:1 (This ratio is 1.25:1 in TIR optics) [37].

While the researches on source sizes continue, multi-TIR lenses are being developed that can be used with any COB LED in order to create a narrower flashing emission. It is thought that a bigger version of COB LED needs a larger optic in order to fully provide its own lighting control in terms of proportion. A compact lens design provides brightness with a small lighting up and of course a smaller optic requires a smaller integrated LED lamp [36].

Increasing lumen outputs of COB and HDF LEDs mean more heat is generated at the same time. When these light sources get more popular, proper heat control will be more critical in terms of performance, diode life and circuit system of the integrated LED lamp. Actually, due to the increasing heat, today the LEDs are encapsulated with silicone rather than epoxy [36].

While matching increases optical efficiency when exposed to light and heat, it may lead to the wearing out of the materials in time. Lenses and reflectors get yellow and this may lead to the color changes and performance inconsistency in the integrated LED lamps.

Heat-tolerant materials attract the manufacturers of LED optic and integrated LED lamps. One of the material options for TIR optics is Polymethyl methacrylate (PMMA) acrylic. This material is preferred for its clarity, UV stability and high conductivity. Nevertheless, its exposure to a long term heat may cause some deformations. Some manufacturers, on the other hand, prefer glass since it is stronger than polymer. However it cannot become widespread because it is heavy, fragile and expensive. Polycarbonate that directly meets the needs of the LEDs is another viable option [38].

While the manufacturers keep developing new options, the studies for new heat-tolerant materials and custom-made optics and the solutions with higher efficiency will continue as well. According to some manufacturers, 3D printer technology has gained speed for the orders in terms of prototypes and printer optics. Such developments will highlight the importance of semiconductor lighting in term of not only being efficient but also having a beautiful and controlled light [31].

## **2.8. Thermal Model**

The difference between the power LEDs of high quality and low quality mostly depends on distinguishing the products designed with superior thermal management to prevent loss in effectiveness, decreased lifespan and color degradation. As thermal management is a key element in ensuring reliable high quality power LED performance, one should be sure to find a supplier that is expert in controlling junction temperature via thermal conduction, convection and radiation techniques and that is very familiar with the considerations such as thermal resistance, substrate material and ambient temperature that play role in thermal management. Specifically, one should make sure they can guide him/her through the following leading active and passive cooling techniques to identify the solution that works best for particular application [39].

Junction temperature can be referred to by some different passive and active cooling techniques. Passive techniques are mostly related to the basic composition of the high power LED technology, on the other hand active cooling techniques necessitate additional power [39].

For some applications with less environmental concerns, passive cooling techniques may be enough. For more complicated applications, passive cooling techniques are often combined with active cooling techniques to obtain desired consequences. Since they do not ask for some additional power – passive cooling options should be tried before applying active cooling methods. Thermal paste, metal core PCBs (MCPCB), heat sinks and passive convection are four most commonly used passive cooling techniques [39]. Active cooling techniques necessitate added power input. Three of the most common active cooling techniques involve fans, water cooling, and thermoelectric cooling [39].

## CHAPTER 3

### 3. DETERMINATION OF TEMPORAL, SPECTRAL AND SPATIAL PATTERNS FOR THE LEDS

This section includes the studies made in order to determine the most effective temporal pattern that will create the expected effects on the target human being when the BSSL is used. First section describes how a change in light affects the human brain. Next section contains the frequencies that cause the desired effects on the human being. The analysis includes the assessment of the experimental data to find the most effective patterns of the light.

#### 3.1. How a Change in Light Affects the Human Brain?

When the intensity and color of the light changes in time, before the perception transmitted from the eye to brain is solved, a second warning is sent from the eye to brain and in this case the brain cannot find time to process the information and these warnings that arrive to be processed by the brain make the brain non-functional. A person exposed to this situation is expected to be incapacitated temporarily [9].

A light flashing over 50 Hz is not perceived by the eye as if it is on and off but rather it is continuously on. The light modulation which is created turning the light source on and off under a 50 Hz frequency is called “strobing”. Studies have shown that the majority of people who are sensitive to the change of light intensity at certain frequencies (15 Hz-70 Hz) may have the symptoms of dizziness, neusea and etc.. Other studies showed epileptic symptoms of people at 15 Hz rate with over 90 seconds of continuous staring at a strobe light [9].

How does strobing confuse a person? It depends on how people process the visual information. The lens of the eye focuses an image of the world on the retina and a dense collection of light-perceiving cells called photoreceptors. When the image is

received and converted to an electrical impulse, the optic nerve transfers it to the brain's visual cortex, which interprets the pictures. The brain has a limited rate or frequency by which it can receive and process visual information. If visual information arrives faster than the brain can process, then the person becomes temporarily incapacitated [7].

The flow of the visual information is disrupted by the strobing in two ways. Firstly, the brightness of the strobe's flash creates afterimages in the brain. If you look at a bright light and then close your eyes, you will "see" an afterimage of the light. Secondly, the frequency of the flashing hovers near 15 Hz and impairs the brain's ability to process visual information, which produces disorientation and nausea. Once the light emitting device is turned off, the nausea lingers for a few minutes as the brain recovers [7].

Brain waves (Electro Encephalographic-EEG) also take place between 1-70 Hz and fall inside the light intensity modulation spectrum of 1-50 Hz. The frequency of our brain waves starts to get synchronized with this modulation as a consequence of the light modulation. This is called "photic brainwave entrainment" [41]. This synchronization results with the symptoms of photosensitivity to be encountered. Photosensitivity (PS) is the response of abnormal visual sensitivity given by the brain to flashes, intermittent light sources or more complex impulses such as television (TV)-video games and visual patterns [42].

The red color at the wavelength of 660 - 720 nm has a high risk of creating crisis depending on blue and white colors. After 685 children who watched the cartoon called Pokemon in 1997 in Japan saw the red and blue lights flashing in the rocket launching scene, they applied to the emergency with attacks and after this incident the role of the colors in the human photosensitivity started to be questioned again [42].

### **3.2. Determination of the temporal pattern of intensity of light of the BSSL**

In our search of designing the most effective BSSL we tried to understand the impact of changes in the intensity of the light (temporal change of the intensity of light), in the color of the light (spectral change of the light), and in the spatial distribution of the light on people when their eyes are exposed to bright, flashing light. Three types of non-destructive effects that impact human vision when the eyes are exposed to a bright light exist: Glare, flash blindness, and bio-physiological effects. The effect to occur depends on the wavelength of the light generally measured in nanometers (namely the color of the light), the energy of the light beam at the pupil of the eye (measured in watts/square centimeter), whether the light source is pulsed or continuous-wave, exposure time and how many colors of light are flashing simultaneously or one after another [8].

The glare effect is a decreased visibility condition caused by contraction of the pupil induced by a bright source of light in a person's field of view. It is a short-term effect that disappears when the light source is extinguished, turned off, or directed away from the subject. Flash blindness is a reduced visibility condition that continues after a bright source of light is switched off. It appears as a spot or afterimage in an individual's vision that interferes with the ability to see in any direction. The nature of this impairment makes it difficult for a person to distinguish the objects, particularly small, low-contrast objects, or objects at a certain distance. The duration of the visual impairment can go from a few seconds to several minutes. The main difference between flash blindness and glare is that flash blindness persists after the light source is turned off, however the glare effect does not [8].

The psychophysical effects of exposure to pulsed light sources are less investigated. Generally, such effects consist of a number of subjective responses ranging from distraction to disruption, to disorientation, and to even incapacitation. Such type of impact is directly relevant to the brain activity, and in particular to brain waves. Brain waves, periodic electrical signals that mirror shifting patterns of mental activity, tend to fall into four categories: beta, alpha, theta, and delta. These categories are related to



the rate of oscillation (frequency) of brainwaves. As it turns out, certain patterns of brainwave activity are also related to the specific mental states.

Beta is associated with normal, waking consciousness; attention directed towards the external environment. You are most likely in the "beta state" while you read this. Beta waves oscillate between approximately 14 and 30 times per second (Hz).

Alpha waves occur when the person is relaxed, doesn't think about anything in particular, sometimes when in an enjoyable feeling of "floating". Alpha waves are often dominant in certain kinds of meditation and for the last twenty years they have been associated with peaceful, lucid mental states (the "alpha state"). They are also often detected during dream sleep. Alpha waves oscillate between 9 and 13 times per second.

Theta exists in the states of deep relaxation and theta activity is also associated with bursts of creative insight, twilight ("sleep") learning and vivid mental imagery. It is also found in more advanced meditators. Theta waves oscillate between 4 and 8 times per second.

Delta is the slowest brainwave activity and it is found during deep dreamless sleep and sometimes in very experienced meditators. They oscillate between 1 and 3 Hz [43].

Brainwave activity tends to mirror flickering light, particularly in the alpha and theta frequencies; this effect is known as the "frequency-following effect." These findings have been used by psychologists for the therapeutic treatment of psychologically unstable patients. However, some studies have shown that many subjects find flashing lights very uncomfortable. Instead of treating disturbed patients, these machines cause harm, especially when the light is relatively bright [43].

Flash durations, flash colors and the effects of rapidly changing frequencies within the alpha-theta band have been, and are still being searched for their impacts on brain activity. The general rule of light-brain interaction from the frequency-following effect is that all three factors play an important role in the alteration of the brain rhythms. As

these factors become more variable and more random, they introduce more modulation, and thus more confusion in the brain rhythms [8].

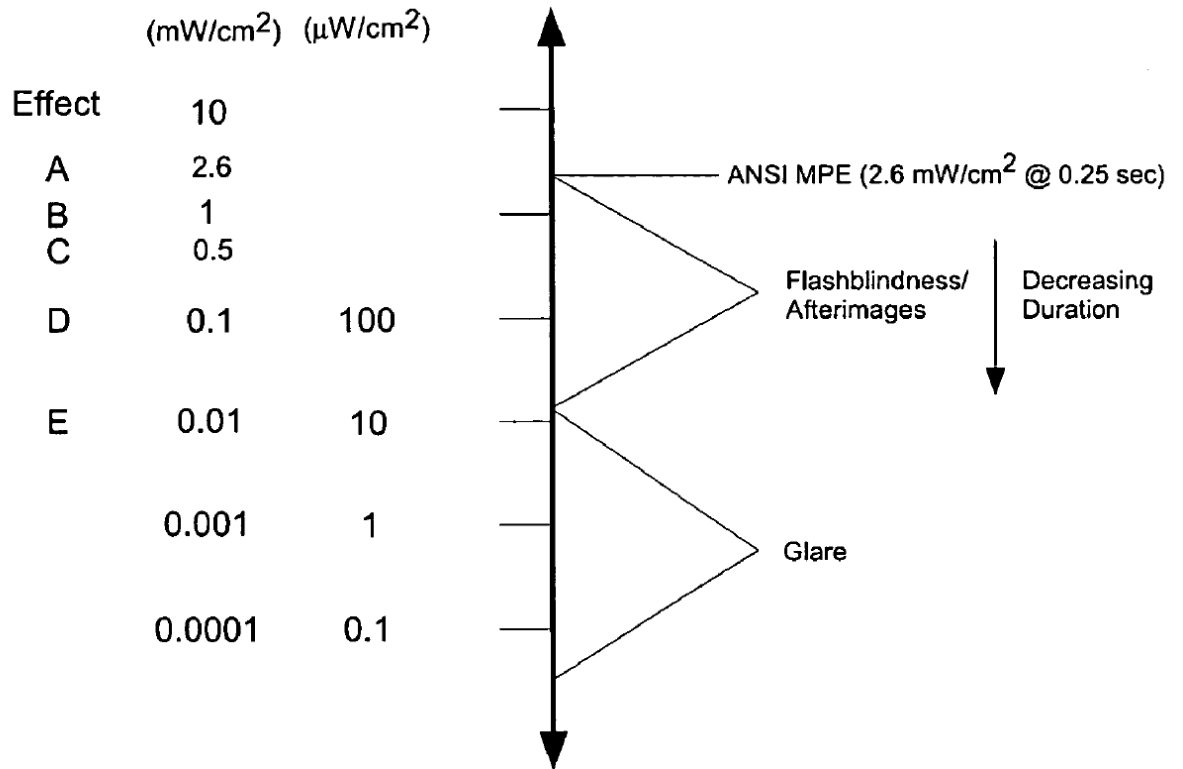
As of the early 1970s, some programs related to optical nonfatal weapons have been started and stopped several times in the USA. On some occasions, safety measures were disregarded, and lasers (which were used as light sources in virtually all cases) caused permanent damage to an individual's eye. Although we used LEDs and did not use lasers throughout the works and studies in this thesis, we used the guidance of the safety standards developed by the Laser Institute of America, ANSI Z136.1-2000, Safe Use of Lasers and Bright Light Sources [44].

We always paid attention to the level of light intensity to prevent the permanent damage to our eyes in our experiments. The critical safety parameter, as defined in ANSI Z136.1-2000, is the Maximum Permissible Exposure (MPE). ANSI Z136.1-2000 presents an MPE diagram that presents the relation between intensity and exposure, and the Eye-Damage Threshold [8].

The Eye Damage Threshold defines the upper boundary of the regime for eye-safe operation (typically measured in  $\text{W}/\text{cm}^2$ ) and ranges from  $0.0583 \text{ W}/\text{cm}^2$  for extremely short exposures to less than  $0.0001 \text{ W}/\text{cm}^2$  for extended exposures. The lower boundary of  $0.0001 \text{ W}/\text{cm}^2$  is also considered to be the lower limit of intensity for any useful degree of glare and flash blindness. For the pulses shorter than 0.01 seconds, the eye typically does not respond sufficiently for any useful effects to occur [8].

The MPE diagram provides parameters for a single exposure, but in this thesis we used trains of pulses (bursts of pulses) to obtain an effective bio-physiological effect.

Different levels of irradiance at the eye will result in different levels of incapacitating effects. Study of Safety Recommendations of Laser Pointers show a chart that classifies visual impairment effects according to different intensities of light for exposure of 0.25 sec (the time equal to the aversion response or blink effect) [45].



**Figure 27** Different levels of physiological effects that are produced from visual impairment induced by various levels of irradiance (irradiance is defined as Watt/area, whereas intensity as Lumen/area) [8]

Fig. 33 indicates the effects ranging from very strong flash blindness (which includes vertigo, disorientation, and startle) to simple glare (see right column in the figure) versus irradiance level on the eye (left column of the figure). The strongest effects appear when the irradiance is at the MPE level or above. The arrow on the right side of Fig.33 pointing down shows a decrease of the efficiency, while the exposure time decreases [8].

Table 2 summarizes the various levels of impairment produced by various levels of irradiance. As shown, these levels (levels A-E) provided guidance for us in developing the temporal (intensity change in time), spectral (color change in time), and spatial (the intensity change in space in time) patterns in time in order to produce the effects by a single exposure for 0.25 seconds.

**Table 2** The Effects by a Single Exposure to Ceaseless Light [8]

	<b>Effects Produced</b>	<b>Equivalent to Irradiance Levels</b>	<b>Required Power (% of MPE level)</b>
<b>A.</b>	Very Strong: severe flash blindness with afterimages, startle, disorientation, vertigo, occasional vomiting	2.6 mW/cm <sup>2</sup> , MPE for a single exposure	100 %
<b>B.</b>	Strong: strong flash blindness with afterimages, startle, disorientation, vertigo	1 mW/cm <sup>2</sup>	38.4 %
<b>C.</b>	Moderate to strong: strong flash blindness with afterimages, disorientation, startle	0.5 mW/cm <sup>2</sup>	19.23 %
<b>D.</b>	Moderate: flash blindness with afterimages, disorientation, occasional startle	0.1 mW/cm <sup>2</sup>	3.84 %
<b>E.</b>	Weak: strong glare, flash blindness, occasional afterimages	0.001 mW/cm <sup>2</sup>	0.384 %

Table 2 summarizes the effects caused by a single exposure to continuous light, but we decided to use trains of light pulses in time, in color and in space in order to disorient and confuse the brain to decode the information to the eye by providing pulses of light in a proper frequency.

The human eye has a maximum sensitivity to green light at 532 nm in daytime conditions, and to cyan (blue-green) color at nighttime. In contrast, the sensitivity to red light (620-630 nm) is a few times less than its sensitivity to green light during daytime, and is extremely low at nighttime. The flashes with the combination of at least two colors of green and cyan provide efficiency during both daytime and nighttime conditions [8].

Very strong physiological effects of colors are known to be used in the art. Blue stimulates the anterior hypothalamus, which includes the main regulating part of the parasympathetic nervous system. This means that all colors in the bluish spectrum—from blue/green through blue to violet—typically have a sedating, digestion-activating, sleep-inducing effects. Red stimulates the posterior hypothalamus and therefore the sympathetic nervous system. Red provokes anger. All colors in the red

spectrum—from magenta through red/orange to yellow—have a stimulating, sometimes even provocative, character. Green mediates between both systems [8].

A side-branch of the optic nerve tract reaches the amygdala directly, by passing the hypothalamus. The two corpora amygdaloidea comprise the color sensitive area of the limbic system, and are highly responsive to the color to which the eyes are exposed. A study indicated that each monochromatic color frequency evokes specific neurons. If the neighbor, but dissimilar color-wavelengths are used, the same neuron stays unexcited. Thus, each frequency in the color spectrum has its own specific neurological and psychological impact. A neurosurgeon, Norman Shealy, M.D., Ph.D. performed a study searching the biochemical changes in the brain after beaming different colors into the eye. Significant changes were evident in the concentration of these neurotransmitters in the cerebro-spinal fluid: norepinephrine (having an identical structure to epinephrine, increasing heart rate, as well as blood pressure), serotonin (mood regulator, lack of norepinephrine causes depression), beta-endorphin (pain killer), cholinesterase (cholinesterase inhibition is associated with a variety of acute symptoms such as nausea, vomiting, blurred vision, stomach cramps, rapid heart rate), melatonin, oxytocin, growth-hormone, LH, prolactin, and progesterone. These findings indicate why emitting different colors into the eye can have a deep effect on the hormonal system, the emotions, stress levels, sleep, brain function, and many other aspects of the person's biochemistry and well-being [46].

Thus, in this thesis in our search for the most convenient pattern of light, we modified both the exposure time (i.e. duration of the radiation pulses) and we used combinations of colors in the flashing lights.

## CHAPTER 4

### 4. DESIGN AND IMPLEMENTATION OF THE BSSL

This chapter covers the subjects what we contributed to the literature with this thesis. Designing the BSSL to incapacitate a person requires a careful attention to four areas:

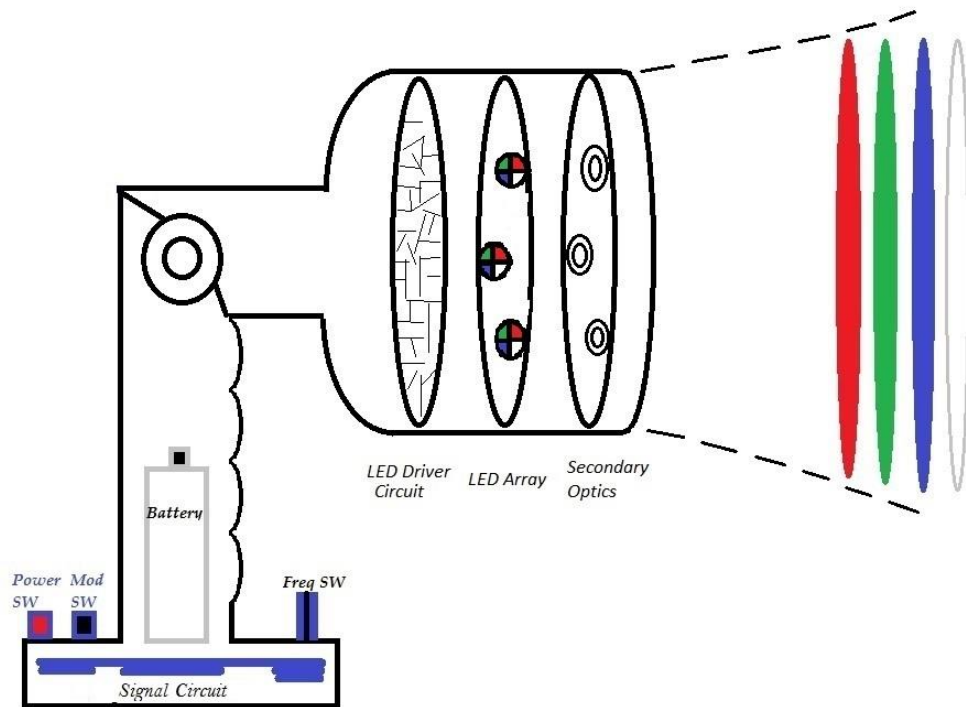
- choosing one or more HBLED (high-brightness LED) light sources to provide the light intensity and colors required,
- selection of a task-optimized secondary optics system to provide the spatial distribution of the light beam emitted,
- selection or designing a high-efficiency power conversion circuit to drive the LEDs properly,
- and developing an embedded software to generate the desired patterns of the light emitted.

In order to find the most suitable pattern of the light to obtain the effects on a human being effectively we needed a system that can produce the light patterns in various aspects:

- temporal change of the intensities of the light pulses,
- spectral change of these pulses in many combinations of different color flashes,
- and the beam shaping (spatial configuration of light beam) of the light emitted.

To do that we first designed and built a prototype BSSL to make all the experiments required to search for the best pattern and to verify the design.

The design of the BSSL is composed of an LED array, an optical system, an electronic control module and a power supply, and a mechanical system that provides housing for all these subsystems.



**Figure 28** The BSSL system schematic

The next section introduces the design of the LED array and optics that are suitable for the BSSL. The other section that follows describes the design of the LED driver circuit and power supply module, the signal circuit, including the embedded software development. The final section in the chapter covers the testing system as a whole.

#### 4.1. LED Array and Optical System

The BSSL must provide the minimum criteria of lighting required for the security purposes (incapacitating a human being) in the situations aimed for use. That's why, these lighting criteria must be defined before the objectives of the design. At this stage, since the device will be used on people, current standards and photometric properties were searched and the lighting criteria were determined. In this first step of the design, the characteristic values to be determined are the followings:

- **Luminous efficacy**; the total luminous flux emitted by the light source divided by the lamp wattage; expressed in lumens per watt (lm/W) [47],

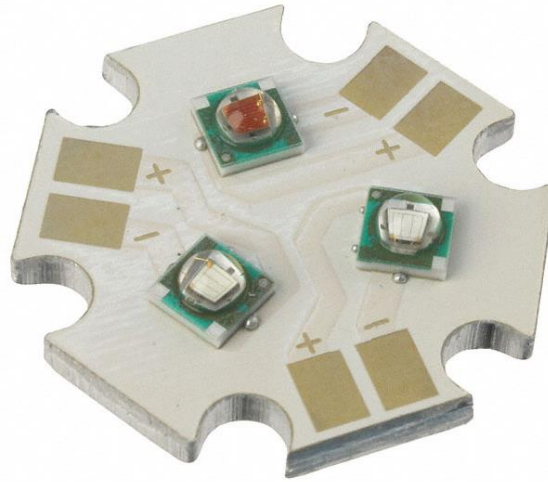
- **Integrated LED lamp (fixture) efficiency;** the ratio of luminous flux (lumens) emitted by an integrated LED lamp to that emitted by the lamp or lamps used therein [47],

- Light distribution,
- Glare limitation.

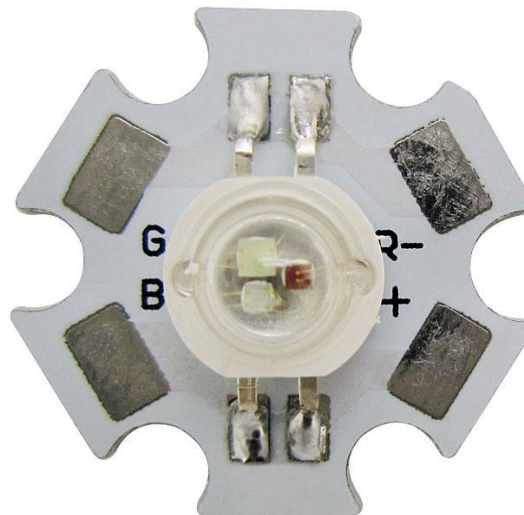
We can not use bare LED chips in our lamp. We had to fix these LEDs, may be in an array of more than one chip, onto a mechanical structure, called an integrated LED lamp, which also provides optical and mechanical limitations on these light sources. Therefore, the design process should include two steps: as a first step determining the best LED light source; and as a second step, determining the best integrated LED lamp that when the best LED light source selected in the previous step is attached, would provide the desired light effects as required.

**First step, selecting the LED light source:** First the colors of the LEDs in temperature of the BSSL were decided. In order to see the desired effects of use of the BSSL, to generate practically all the colors that our eyes can see the LED/s must be red (645-740 nm), blue (400 – 485 nm), and green (500 -565 nm) and they must flash at the desired frequencies. Combinations of these primary colors will provide us the required color. Although, today red, green and blue LEDs are generally used in separate chips in the lighting products as seen in Fig. 35, there are the types that have 3 colors on one LED chip shown in Fig. 36.





**Figure 29** Red, Green and Blue LEDs on different chips



**Figure 30** Red, Green, and Blue LEDs on one chip

In the design, the desired effects are expected to occur with flashing of three different colors of red, green, and blue (RGB), and an additional color is required in order the BSSL to be used as a flashlight when necessary. As we stated, nearly all the colors in nature are acquired through the use of only these three primary wavelengths (RGB) in different intensities. When three of them are mixed for 100%, white light is obtained. The additional color required for the flashlight was thought as white in the design and it could be obtained with the blending of these 3 colors. As we explained in the previous chapter, when we made a study on optical tools, we observed that the

simultaneous lighting of these 3 colors in a LED will cause the light that can not be focused properly, and a light intensity obtained from the LEDs would decrease. For this reason, we decided to use a LED chip of 4 separate LEDs of red, green, blue, and white colors.

The lights of Red, Green and Blue LEDs were used because they create the effects such as daze, losing control and vertigo when reached to the brain flashing in different frequencies. White color, on the other hand, allowed the device to be used as flashlight mode when necessary for lighting. That's why the light intensity of the LED used must be high. The higher the light intensity, the higher the effect on the human target. The LED chip includes 4 different LEDs of different color each on the same chip, the efficacy of the LED used in the design is different for each LED of different color. A higher efficacy is important for flashlight (lantern) mode for the white LED.

The LED to be used in the design must fulfill the environmental temperature conditions of the work for the police force, soldiers and such officers that would use the BSSL. They normally use the device in numerous cold and warm environments in operations. Considering that the device will be turned on and off for many times during the operations, the light source to be used should meet this and must have a long life. In order to meet these requirements, many LEDs have been tested and their advantages and disadvantages were investigated. When we made a design by using 4 different LED chips for 4 different colors, we observed that it is difficult to form a beam on a single spot by focusing colors from 4 LED chips, and thus it was not possible with this configuration to affect the target human being efficiently.

Next, we tested the configuration that has 4 separate colors of LEDs on one LED chip and measured the total light flux, efficacy, light distribution curves and glare factor. We decided to use Edison Federal 5050 Series LED chip seen in Fig. 37, because Federal 5050 Series LED chip is small, surface mounted, compact and bright, and it also provides multi-color packaging flexibility. Thus, we decided that this LED chip that includes 4 LEDs on a single semiconductor chip, among the other alternatives on the market, would meet the best of our requirements regarding the desired LED color quality, the LED efficacy [lm/W], the total light flux, the light distribution, and the glare limitation [48].



**Figure 31** Federal 5050 Series LED chip [48]

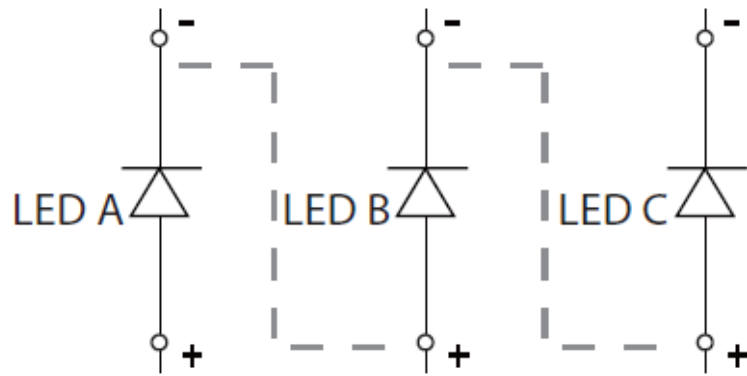
**Second step, determining the integrated LED lamp:** After we selected the LED chip that meets our lighting requirements we identified our design objectives. The critical design objectives are related to the determination of the light patterns and the output of the light required for the identified patterns. The light flux emitted by the LEDs when fitted in integrated LED lamps to the light flux in their bare state, that is, when they are not attached to the integrated LED lamp is named as Light Output Ratio (LOR). One of the design objective of us is to make the LOR of the lamp as high as possible. Our design steps in meeting this are:

- The determination of necessary light distribution and patterns in order to create the desired effect,
- The LED array design for the light output required to get the patterns,
- The total light flux from the integrated LED lamp [lm],
- The light distribution,
- The junction temperature of the LEDs (working temperature of LEDs).

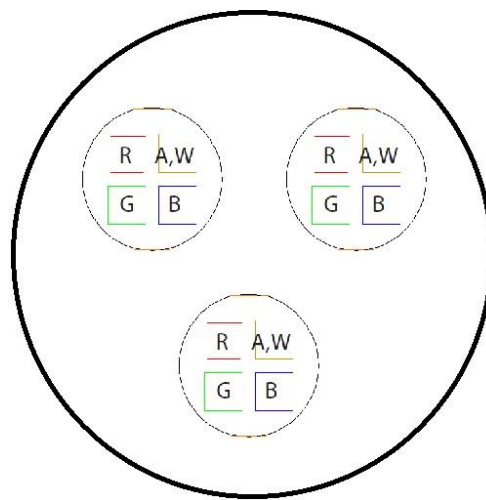
We would determine these in meeting the design requirements of the BSSL. The design requirements of the BSSL are: BSSL would be a compact and non-lethal system

that is composed of red, green, blue and white LED arrays, causes the target human being to get incapacitated with the light patterns emitted by the LEDs during the operations at 7 – 15 Hz frequencies of pulses of lights of combination of different colors, affects the target up to 20 meters range and therefore, focuses the light directly on the target, and the BSSL could also be used as a flashlight, when needed. In addition to these, the cost of each BSSL unit when produced should not exceed 250,00 US Dollars.

We first determined the number of LED light sources to be used in the BSSL. The number of LEDs directly affects the light flux, power dissipation and the cost of the integrated LED lamp. The higher the total light flux emitted from the lamp, the higher the effects it imposes on the target human being. Light flux of the LEDs depends on the factors like junction temperature and forward current. Junction temperature shouldn't be too high to affect the efficiency of the LED. For this reason, the LEDs must be separated physically from each other so that they can dissipate the heat generated in their junctions. Forward current shouldn't exceed the value of the maximum forward current specified by the manufacturer. The light, on the other hand, should affect the target human being temporarily and not cause a permanent damage, i.e., its intensity shouldn't exceed a certain light flux value. Since the BSSL is designed to be used by the security officers during intervention in the social events and the operations, it should be designed in different sizes depending on the situation of use. For instance, besides used by an officer personally, it can also be used by mounting it on the vehicles like the TOMA (Riot Control Vehicle) or by installing on the appropriate facilities on the borders for border security. In the first design when the BSSL is used by the officer personally on the target, optical and thermal losses were considered in order to identify the exact number of necessary LEDs and it was observed that the use of 3 Federal 5050 Series LEDs are sufficient for meeting the requirements.



**Figure 32** Wiring Diagram of LED array used in the BSSL



**Figure 33** Front view schematic of the LED array PCB used in the BSSL

In the design of the LED array, sufficient light intensity was obtained from 3 LED chips, each having 4 LEDs on a single chip, connected in series. As seen in Fig. 39, the LEDs driven each with 350 mA provide the light fluxes in 4 colors as given in Table 3 [48]. Since 3 LED chips have been connected in series they provide the light flux of red LEDs of 118,2 lumens, green LEDs of 210 lumens, blue LEDs of 41,4 lumens and white LEDs of 270 lumens.

**Table 3** Luminous Flux at 350 mA of Federal 5050 Series [48]

<b>Emitter Type</b>	<b>Color</b>	<b>Min Luminous Flux@350mA (lm)</b>
RTBW (Red through Green with Blue)	Red	39.4
	True Green	70
	Blue	13.8
	Cool White	90

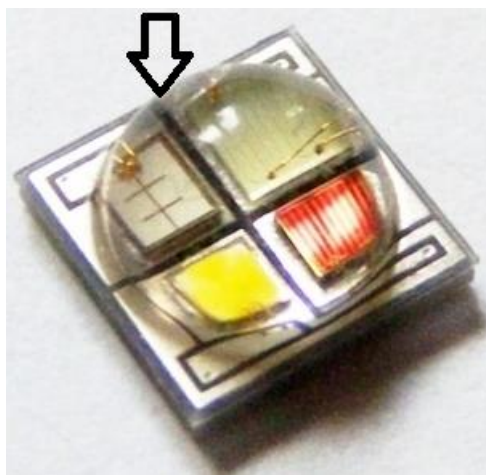
The efficiency changes with the factors like the arrangement of the LEDs within the integrated LED lamp, the physical properties of the integrated LED lamp and the material used.

Thermal efficiency depends on the junction temperature of the LEDs. Light flux decreases with the increase in the junction temperature. LED catalogues of many manufacturing companies provide the light flux values at the junction temperature of 25°C. Since the temperature value in real operation conditions is most probably higher than this catalogue value, we performed the thermal analysis of the lamp, identified the operation temperature of LEDs and we determined the light fluxes at this temperature. We used these values instead of the catalogue data.

Optical efficiency of a component is normally defined by measuring how much of the total flux of light sent is reflected, through the optical surfaces defined [38].

Optical efficiency is related to the optical design of the integrated LED lamp. The light flux emitted decreases due to the loss within the lamp. The losses can occur when the light is absorbed by the lamp or the light reflects back into the lamp. Optical setup is important for the optical efficiency. In the design, we examined two kinds of optics, namely the primary optic and the secondary optic, and considered the optical efficiency of them.

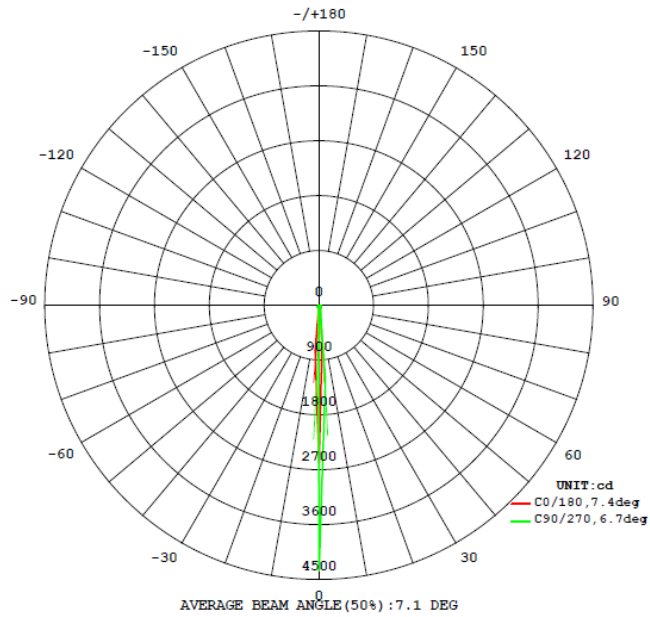
Primary optic is related to the light source, i.e., the LED. We selected the LEDs having a primary optic as shown in Fig. 40.



**Figure 34** The lens as the primary optic on Edison Federal Series LED

Secondary optic is related to the lens or reflectors. The secondary optic should be able to produce a scatter-free light beam. These setups are used for the light to affect the target at a long distance without being scattered. For a scatter-free light beam, the type of the angle of the lens or reflector used in the design is important. After the angle is determined, it is necessary to decide whether a different optical setup will be used for each lighting component or the same optical setup will be used for all the lighting components.

Among the criteria of the design, the focusing of the light beam on the target at a distance of 20 meters from the light source is important. We made some experimental studies in order to obtain this focusing of the beam. At first, the experiments were performed using different reflectors at different angles with Everfine GO - 2000 Goniophotometer. We observed that when a multi-reflector was used, the light was scattered and did not reach to the required distance. When a single reflector was used on the other hand, we observed that the light intensity got higher when there is a narrow angle reflector. The light beam seen in Fig. 41 shows the output of the light measurements taken with  $7,1^\circ$  reflector and this reflector provided the highest light intensity in the experiments.

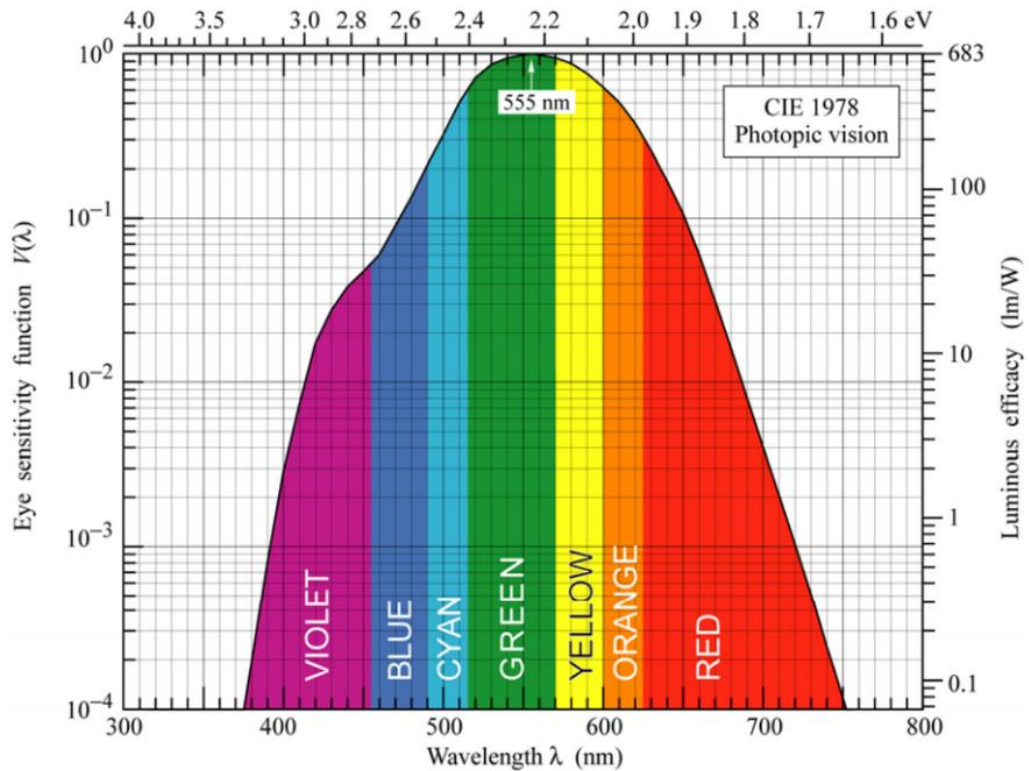


**Figure 35** Photometric test result with a single-angle reflector for the same radiation intensities of the red, green, and blue LEDs

Secondly, in trying to obtain the desired light intensity at a distance of 20 meters, we performed the experiments with the lenses with single/ multi and narrow/large angle lenses. It was observed that when the angle is large, the light beam cannot be collimated and, therefore, cannot reach to the desired distance. We saw that when multi and narrow-angle lenses are used, although the light gets scattered the light intensity on the target is higher than single-angle lenses. In the single and narrow-angle lens, no scattering and a higher light intensity were observed compared to the measurements with multi-angle lenses. In Fig. 42, the photometric test report obtained from the experiment made with 2.3° single lens is shown.







**Figure 37** "Human's eye sensitivity function and luminous effectiveness, measured in lumens per watt of optical power" [49]

Because of the human's eye characteristics shown in Fig. 43, the blue and the red light are seen as if they were not as bright as the green light. Therefore, although the measurements were made for the same radiant (not photometric) intensities of the three chips of blue, green and red colors; when they are measured photometrically by applying the human eye filter shown in Fig. 43, green was having a high luminous intensity, red was measured lower than green, and blue was only barely seen as shown in Fig. 41 and Fig. 42.

In line with the tests, regarding reflectors, we decided that secondary optics was not preferred to be used in the BSSL since the reflector efficiency was very low. However, regarding lenses, we obtained the desired light output by using the narrow-angle single-lens, and decided using this secondary optic method in our BSSL.



**Figure 38** Secondary optics of the BSSL

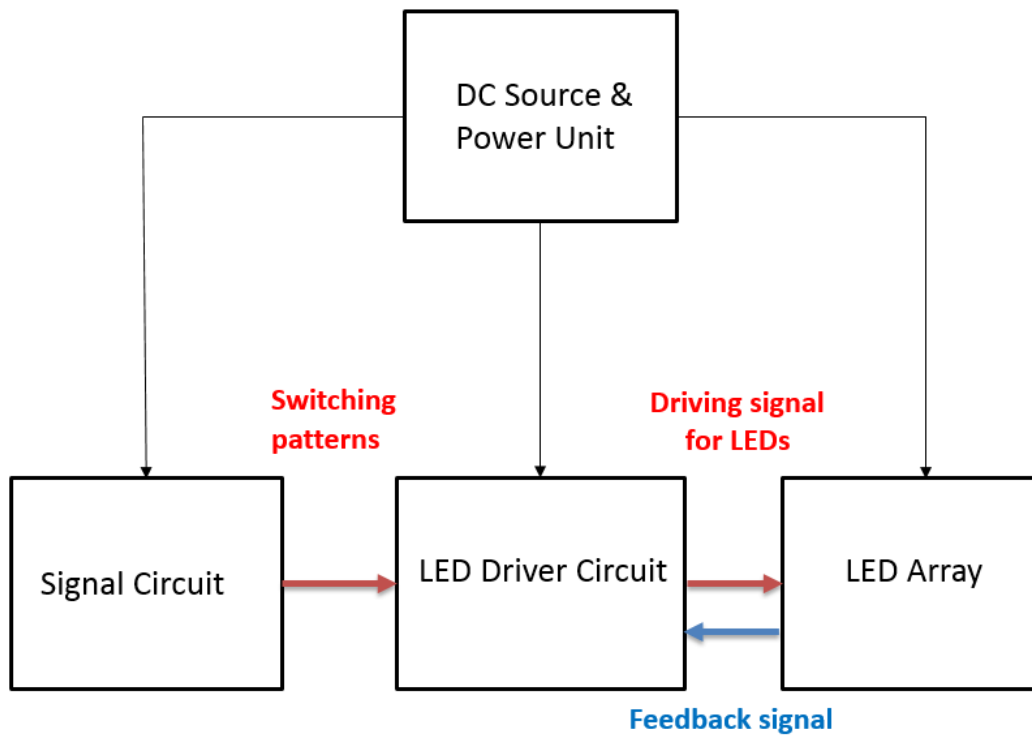
#### **4.2. Designing The Electronic Control Unit of BSSL**

The block schematic for the electronic control unit of the BSSL is given in Fig.45.

There are four main electronic components:

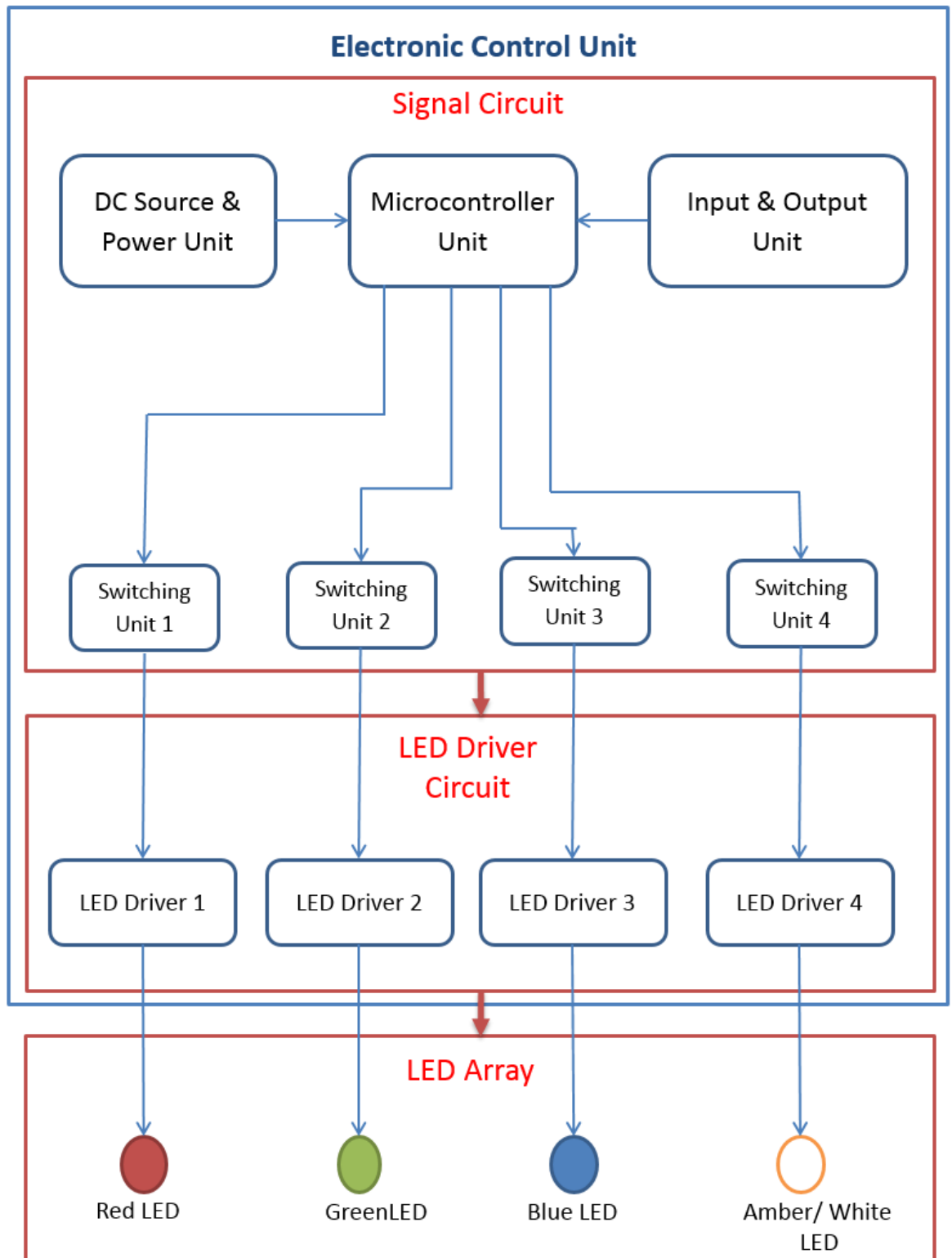
- The DC source and power circuit,
- The signal circuit
- The LED driver circuit
- and the LED array.

The Electronic Control Unit (ECU) contains the first three circuits. In the design stage of the BSSL Project, a three-stage ‘Electronic Control Unit’ design was realized in order to test the LEDs in different colors and different frequencies. The ECU is shown in Fig. 46.



**Figure 39** Block Schematic for the Electronic Control Unit (ECU) of the BSSL

The ECU allows us to generate the temporal and spectral changes of the light pulses depending on the user ‘mode’ choice. We installed two user modes: The flashlight mode (as a lantern) and the strobing mode from 7 Hz to 15 Hz. After the user selects the mode s/he desires, the ‘Signal Circuit’ transmits the light in the desired synchronicity of the selected mode to the ‘LED Driver Circuit’. The LED Driver Circuit, in accordance with the signals it receives from the Signal Circuit, generates the voltages and currents as required and applies them to the LED array.



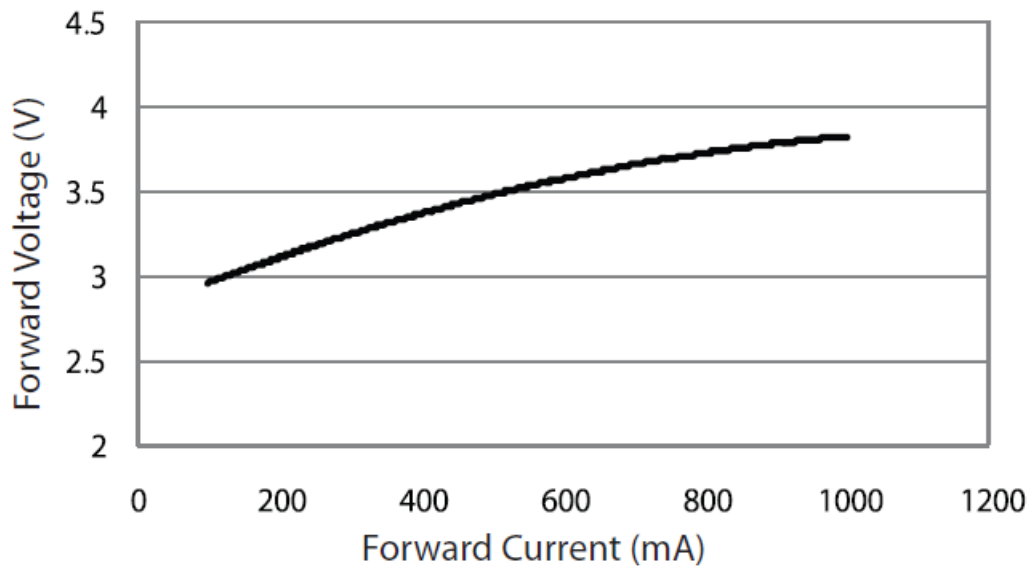
**Figure 40** Detailed Block Schematic of the Electronic Control Unit

#### **4.2.1. The LED Driver Circuit**

In the BSSL, four LEDs operating with 2-4 V DC voltage of 1 Watt power capacity each and emitting light flux of 39.4 lm for red, 70 lm flux for green, 13.8 lm flux for blue and 90 lm flux for white at 350 mA were used. In designing the BSSL, our main aim is to deter the target human being with the temporal, spectral and spatial changes in the light. This necessitates not only high-intensity light output fluxes but also providing these high fluxes when the LEDs are turned on and off in time with the PWM. Using secondary optic system allows us to use smaller forward currents in obtaining the desired effects.

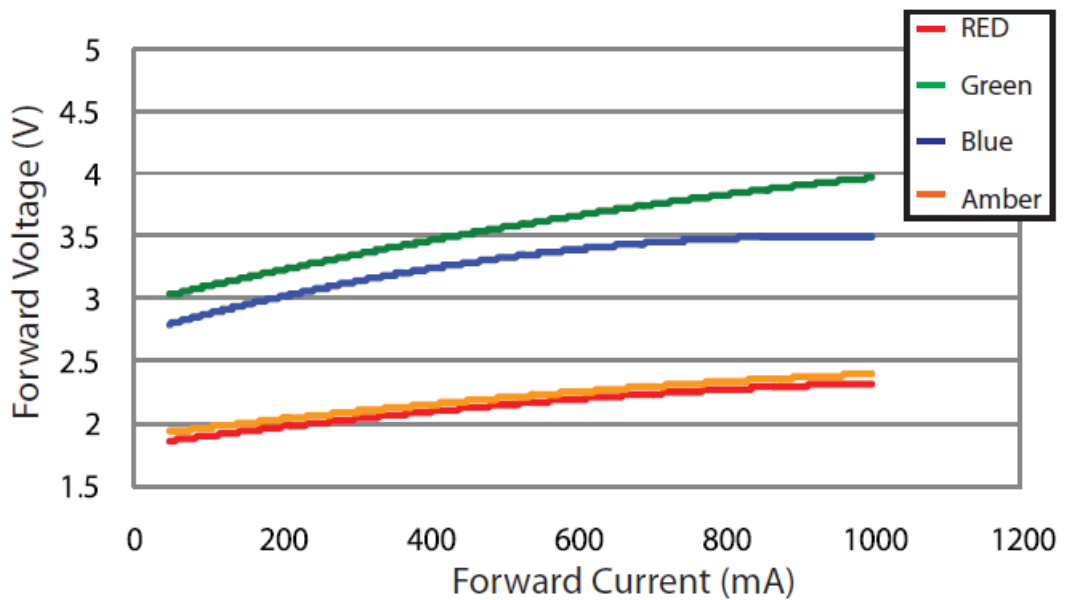
We have to restrict the current flowing the LEDs. Otherwise, the high current causes the junction temperature of the LEDs to increase. As the junction temperature becomes higher than a limiting value, LEDs cannot withstand the temperature and will break down. Light output of LED is proportional to the forward current and identified by the manufacturer for a certain current range. If the current exceeds the range recommended by the manufacturer, the glow of the LEDs can increase however light outputs may quickly decrease due to temperature rise within the device and it may lead to LEDs to have shorter lives. Lifetime of an LED is defined as the time period it takes from the first use to the time when the light output is reduced to the 70% of the light output in the beginning.

In Fig. 47, current-voltage change of white color of Edison Federal Series LED is provided, and in Fig. 48, current-voltage change of the other colors is given.



**Figure 41** Forward voltage vs. forward current for white series [48]

As seen from Fig.47 when the forward current increases the forward voltage appearing across the LED increases slightly.

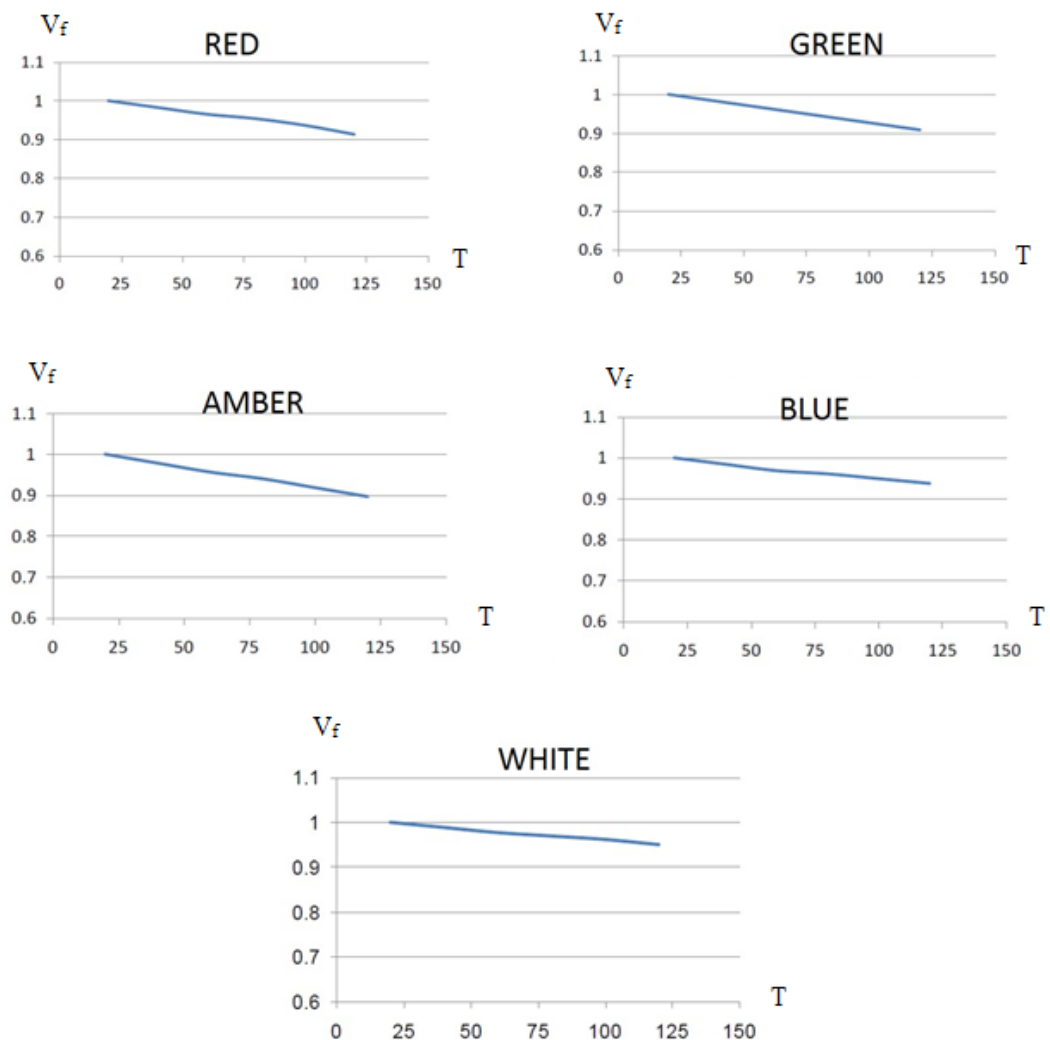


**Figure 42** Forward voltage vs. forward current for other colors [48]

From Fig. 48 we see that all the LEDs forward voltages increase with the forward current, however for green-colored LED the effect of change in the forward current is slightly higher than the other colored LEDs. We also see that although a red-colored LED has a forward voltage around 2 volts, a blue-colored LED has a forward voltage

around 3.5 volts. These differences in forward voltages for different colors come from the fact that different materials that were used in getting different colors in LEDs would have different levels of band gaps and this causes the different forward voltages. The higher the bandgap of the active material the higher the forward voltage of the LED.

Obtaining a desired light output depends on physical size, type of the material and the operating temperature of LED. When LED temperature increases, irrespective of the color of the LED, the forward voltage decreases as shown in Fig.49.



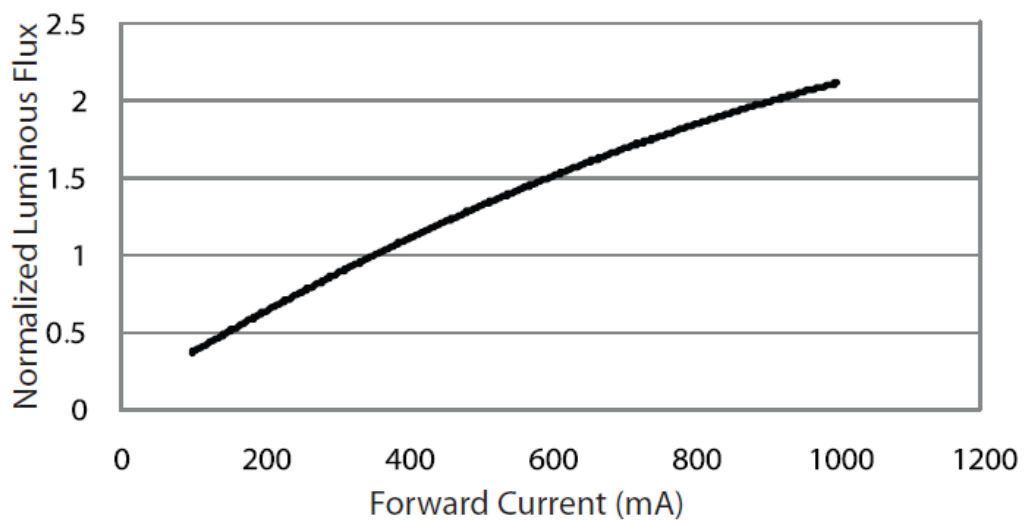
**Figure 43** Normalized forward voltage vs. junction temperature in degrees Kelvin [48]



Increase in the current increases the heat generated in the junction. If the current is not limited, the junction may break down due to heat. The problems of voltage changes and the light output variations and short life are prevented by driving the LED light sources with a regulated constant current power supply.

As we explained in Chapter 3, LED Drivers are the electronic circuits which generally drive the LEDs in one direction, control the average current intensity as well, and can at the same time enable constant voltage values necessary for the LED package. As we showed in Chapter 2, LEDs are driven with linear driver circuits and switched-mode (nonlinear) driver circuits (switch-mode power supply, SMPS).

Light output of the LED light sources increase with the increase in the driver current. However the efficiency is affected by this. Fig. 50 indicates this relation. There is a current value shown in the datasheets of LED lamps normally. This current value is a reference point for the other technical information. Higher driver current than those recommended by the manufacturer leads to excess temperatures and low lumen outputs.



**Figure 44** Luminous flux vs. forward current for white series [48]

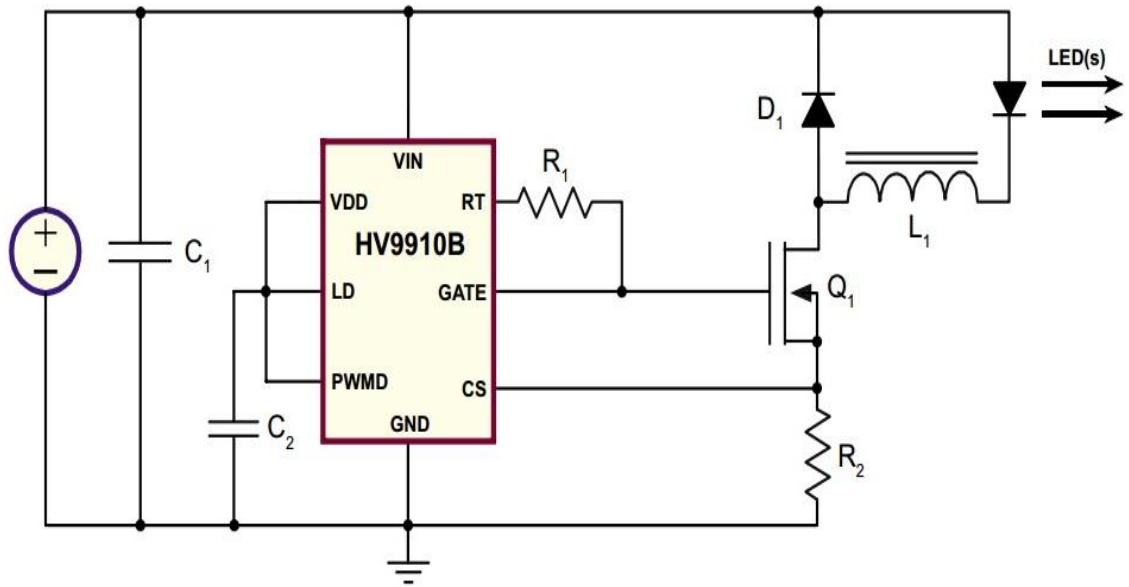
In the BSSL design, in order to avoid the temperature runaway problem and keep the current constant, Switch Mode Power Supply (SMPS) was used. This power supply converts the input signal to the output signal by switching it with a switching element

of a MOSFET. Output current is controlled by keeping its duty cycle (D) properly achieved by the pulse width modulation (PWM) method.

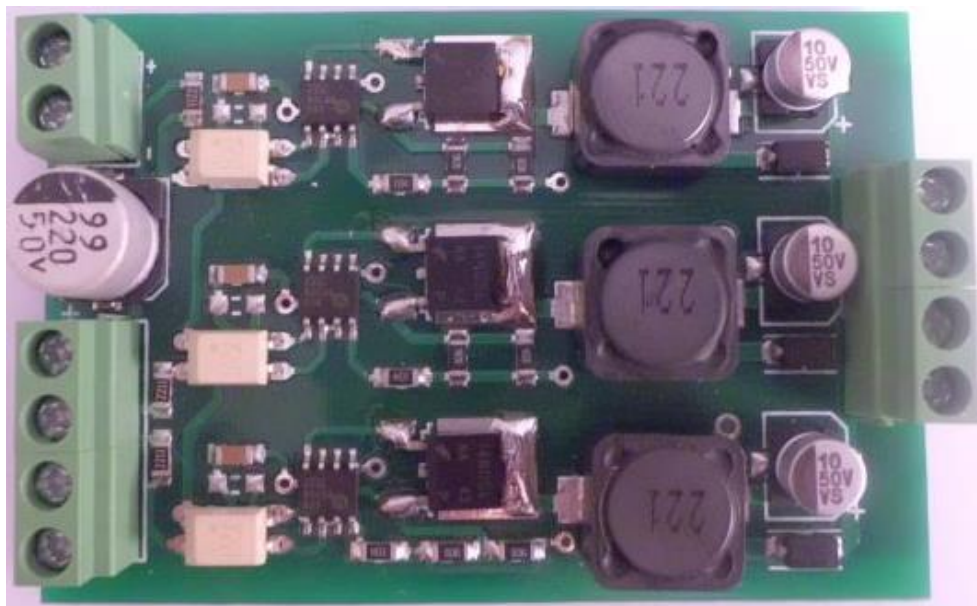
In the BSSL we decided to use an SMPS of a Buck-type since output voltage of the BSSL is lower than input voltage and the efficiency of Buck regulator is pretty good [30].

At this phase, we had to make a decision on whether we will design the SMPS driver circuit from the scratch (discrete solution) or we will use readily available and operationally-verified SMPS drivers in the market containing an integrated circuit (IC) which have the MOSFETs internally (integrated solution). The discrete solution uses a controller IC, external MOSFETs and passive constituents to build the power supply on the system board. The main reason to choose a discrete solution is low component bill of materials (BOM) cost. However, this requires good power supply design skills and relatively long development time. A monolithic solution uses an IC with integrated power MOSFETs to further reduce the solution size and component count. It requires similar design skills and time. A fully integrated power module solution can significantly reduce design effort, development time, solution size and design risk, but usually with a higher component BOM cost [30]. However, since we had to drive the power MOSFETs for light pattern generation as well besides their switching workload already to regulate the output current and voltage to drive the LEDs, we chose the discrete design method.

We did not design the buck mode SMPS ourselves, but preferred using a commercially available one that satisfies our requirements. We decided to use a commercially available buck regulator that include an HV9910 IC, which is designed to drive the LED array composed of one or more LEDs by converting the higher input voltages to the lower output voltages at a desired output current level. The circuit schematic of the buck-type SMPS we chose is given in Fig. 51, and the SMPS itself is seen in Fig. 52.



**Figure 45** Schematic of the buck-type SMPS Regulator using HV9910B [50]



**Figure 46** Buck type LED driver circuit we chose for the BSSL, a no name buck driver available on the market

This driver was selected due to the followings:

- It has an efficiency up to 93% with the switch-mode power circuit,
- It has a large input voltage range (9-30V DC),
- It has 3 channel options at 350mA constant current,

- A reverse polarization protection is available on the input,
- It has a small size (4.2cm x 3.2cm x 1.2cm),
- It doesn't need an extra cooler for the driver,
- And it has a very low cost (\$ 5,00).

#### **4.2.2. The Design of the Signal Circuit**

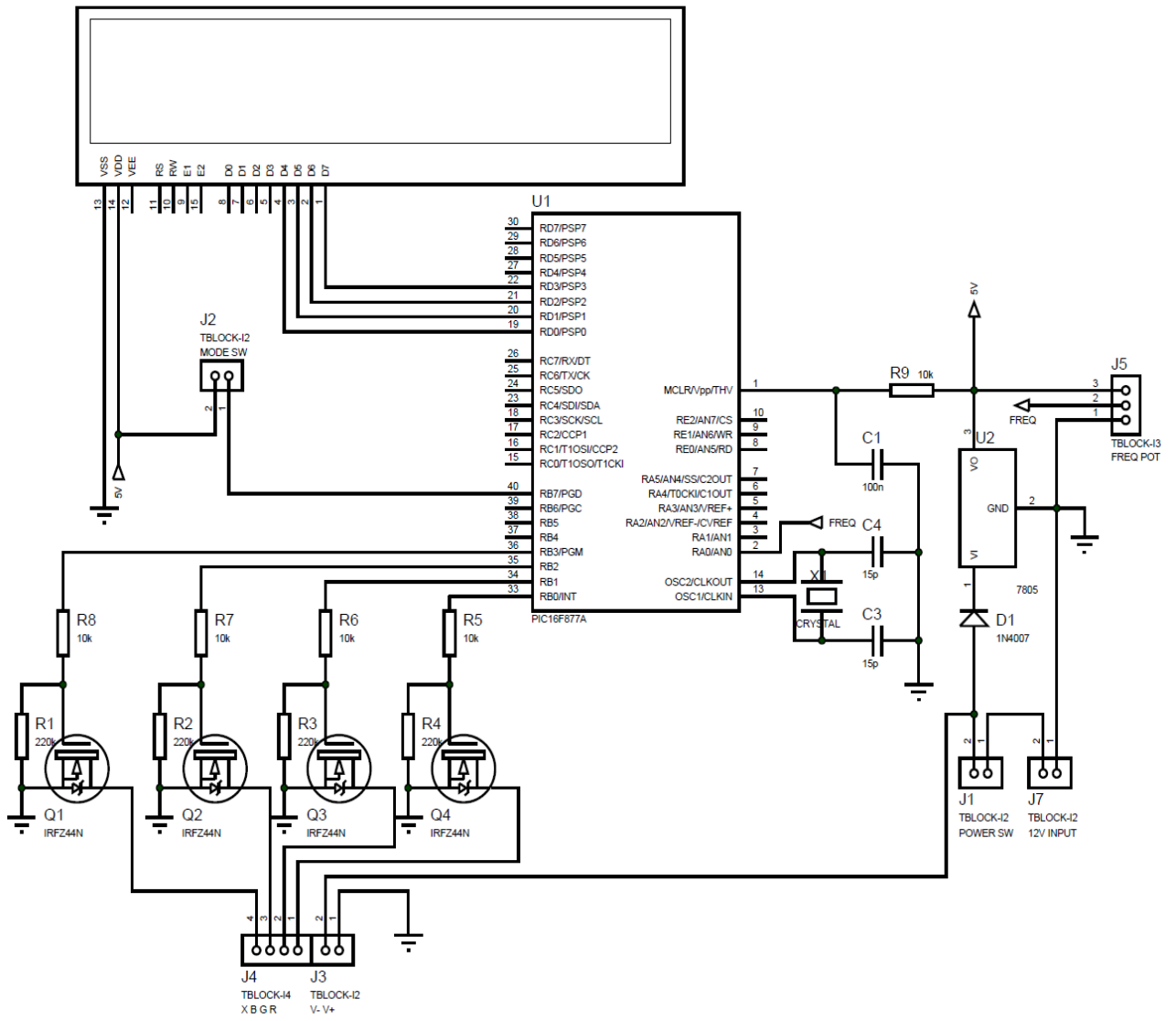
In each stage of the BSSL project, the 'signal circuit' was used to generate the pattern of light pulses that could provide the incapacitating effects on the human target with the LED arrays in different numbers and colors. For the 'signal circuit' a hardware and an embedded software were designed and developed. In this section, these hardware and software are explained in detail.

##### **4.2.2.1. The Signal Circuit's Hardware**

The 'Signal Unit' was used to generate different signals by means of an embedded software running in the micro controller (16F877A) it includes. The light pulse patterns are changed temporally and spectrally by the Signal Circuit, which consists of four main hardware units:

- The Microcontroller Unit,
- The Input & Output Unit,
- The Switching Unit,
- The DC Source & Power Unit.

The circuit layout of the Signal Circuit is given in Fig. 53.



**Figure 47** Layout of the Signal Circuit of the BSSL

#### **4.2.2.1.1. The Microcontroller Unit**

In the microcontroller unit design, PIC 16F877A microcontroller from Microchip was used together with 20 MHz crystal oscillator. PIC 16F877A makes it possible for us to control the change of the desired frequency simultaneously with 3 different LED arrays and in 3 different frequency synchronicities. In order to use more than one LED array simultaneously in different frequencies from the other LED arrays, analog signal inputs should be generated and applied to the LED drivers that drive the four channels of LED arrays. Also, since four output ports were used for driving each LED array, B, C, D, E ports available in PIC 16F877A are very useful.

We developed the software program for this microcontroller to generate the desired patterns of switching signals temporally and spectrally to drive the LED arrays. When these signals are applied to the LED drivers for the four channels, the LED arrays in each channel are driven simultaneously to produce the light effects required on the target.

#### **4.2.2.1.2. The Input & Output Unit**

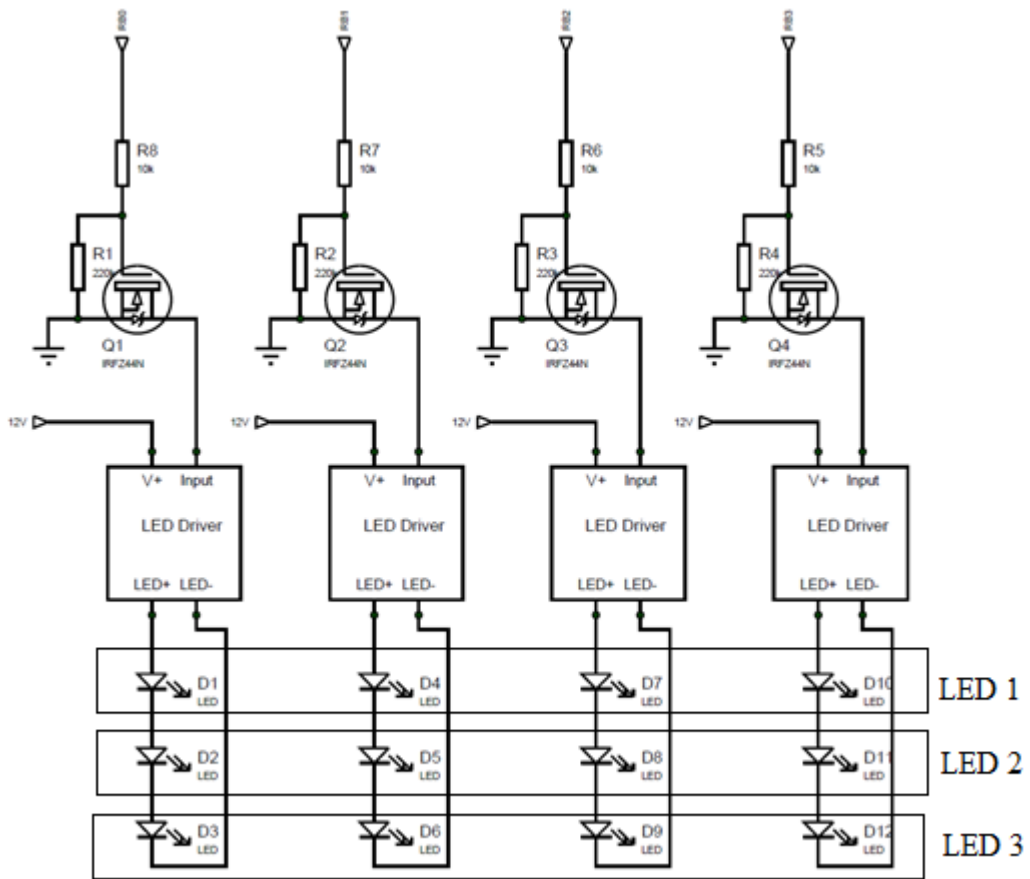
In the Signal Circuit used during the tests, one mode selection switch (0-5V) connected to the B7 port of the microcontroller and one adjustable resistor connected to the A0 Analogue input of the microcontroller for the required inputs. When the mode selection switch is switched on the signal card is switched into the ON mode, the device functions in the mode of flashlight, and when it is switched OFF the device shifts to the strobing mode. This is also managed through the embedded software program developed.

#### **4.2.2.1.3. The Switching Unit**

The Switching Unit we designed is shown in Fig. 54. As seen, the four n-channel MOSFETs (IRFZ44N), drive the individual LED drivers with the signal applied from the microcontroller circuit. The LED drivers have their own switching MOSFETs to generate the PWM signals required with much higher frequencies than those generated

by the microcontroller. Our light patterns are generated by the microcontroller within the range of frequencies less than 15 Hz. The patterns of light are applied to the LED arrays by means of the four MOSFET switches (Q1, Q2, Q3, and Q4) for each color. As shown in Fig. 54, these patterns are then generated on the LED arrays by the individual LED drivers, each for one color on each LED chip. Each LED driver drives three LED chips connected in series.

In order to generate the forward currents that flowing through the LEDs at first each output of the microcontroller is applied to the gates of the MOSFETs that drive the corresponding LED drivers. Ground is provided to the source port of MOSFET when it is switched to ON state by the signal from the microcontroller, as seen in Fig.54. In the BSSL we have 3 individual LED chips, each of which has 4 LEDs of four colors: Red, green, blue and white on one chip. In the circuit schematic given in Fig.54, each of 4 drivers is dedicated to one color, that is, each driver provides the current for the 3 LEDs of the same color on 3 LED chips. For instance, the LEDs denoted as D1, D2, and D3 in Fig. 54 refer to the same color on three different LED chips; so are D4, D5, and D6 and so on.



**Figure 48** Switching Circuit of the BSSL, each driver provides the current to the individual LEDs of red, green, blue and white color on 3 different chips

#### 4.2.2.1.4. The DC Source & Power Unit

In Fig. 54 we see that 3 LEDs are connected in 4 parallel branches. Each driver provides the forward current for the 3 LEDs. We had chosen 350 mA forward current for each LED, and at this current value, as calculated from Fig.47 the white LED has a forward voltage of 3.3V, and as calculated from Fig.48 the red LED 2.1V, the green LED 3.4V, and the blue LED 3.1V. Therefore, for the 3 white LEDs in series connection the driver has to provide 9.9 V and 350 mA, for the 3 red LEDs in series connection 6.3 V and 350 mA, for 3 green LEDs in series connection 10.2V and 350 mA, and for 3 blue LEDs in series connection 9.3V and 350mA. For the 4 drivers in parallel we need  $350 \times 4 = 1400$  mA current to be provided at minimum. To provide this current and the highest of the voltages, 9.93V we decided to use 6 lithium-ion batteries of 3,7V – 3200mA as the power source of the signal card. The two packages, each of which contains three rechargeable batteries first were serially connected, and then



these two packages are connected in parallel with each other. The DC source obtained as a result provides a voltage of 11,1V, at a current capacity of 6400mA. One LED uses maximum energy of 350mA-hour. There are 4 LEDs in the LED Array in parallel and so when the device is used in the mode of flashlight; it takes maximum energy of 1400mA-hour (The loss in all connections and the amount of the current taken by the signal card and LED driver circuits are too little to consider so they have been ignored). In line with this data, DC power source formed to supply the signal card provides a minimum of 4.6-hour lifetime. Furthermore, when the device is used in flashing mode, LEDs are not turned on continuously but are switched on and off at a certain frequency and so the energy required decreases more and the lifetime of the device in flashing mode becomes much longer than 5 hours.

For the general control of the device, an ON/OFF switch was fitted on the signal card input in order to cut the current from the battery.

#### **4.2.2.2. The Signal Unit Software**

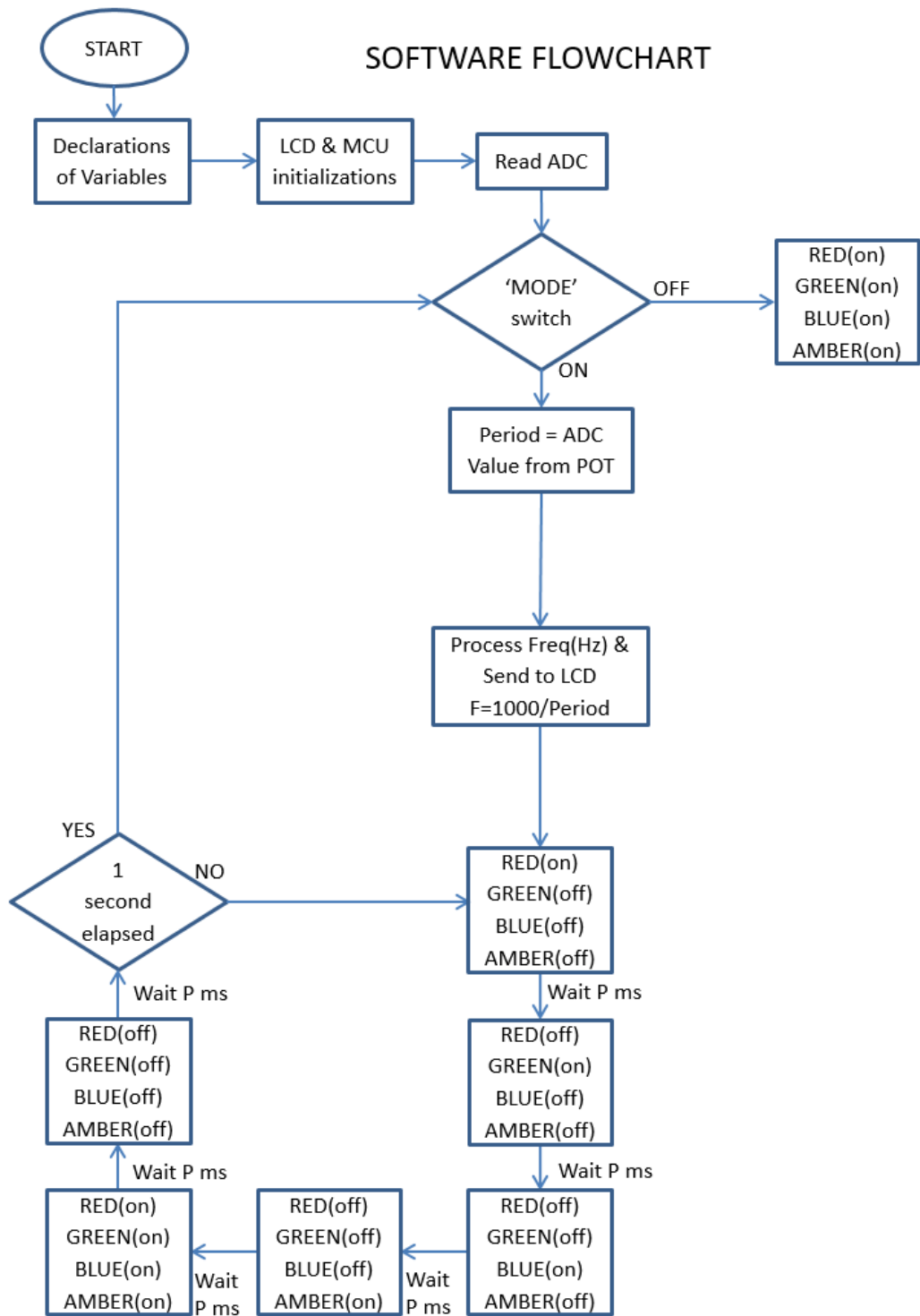
We designed and developed the embedded software required that enables us to generate the patterns of intensities and colors of the light pulses provided by the LEDs. The software is loaded into PIC 16F877A microcontroller that provides the control and management of the signal unit, in accordance with the patterns defined by the embedded software. For the software code development, C programming language was used for its flexibility and commonality. In order to convert the developed software code to the machine language, a CCS C compiler was used.

In developing the software we paid attention to the followings:

- The definitions of the variables to be used in the program,
- Required file for driving the LCD,
- The definitions of the timer and ADC to be used in the program,
- The program was designed as infinite loop after this step.
- Depending on the mode selection switch, the device operates in flashing mode or strobing mode.

- Over a variable resistor connected to the A0 port of analog to digital converter (ADC) module on the microcontroller, an analog voltage is introduced as defining the period value.
- In order to verify the accurate display of the values when it starts, a “TEST STRING” is transmitted.
- With the method of counting the pulses taken from the timer of 1 msec, the value from ADC per 1 sec is read and period and frequency values are calculated based on this value.
- Calculated frequency values are shown on the LCD.
- LED array is flashed on with the following order by waiting as much as the calculated period value between the steps: only red – delay P – only green – delay P – only blue – delay P – only White/amber – delay P – all colors (white) – delay P – no color flashes – delay P. Here P denotes the period selected.
- When necessary, all the colors could flash and emit a strong white light to use the device for lighting purpose in flashlight mode.

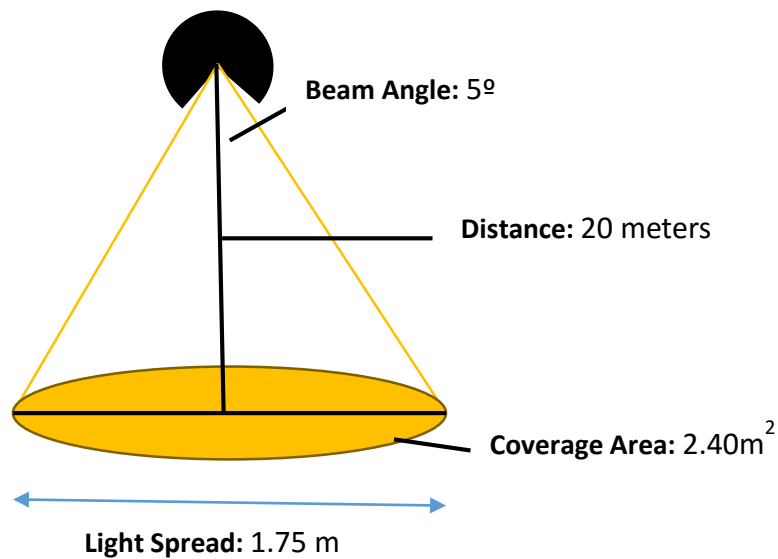
The codes of the software are given in Appendix E.



**Figure 49** Software Flowchart for generating light pulse patterns for the BSSL

### 4.3. Tests and the Results

Many measurements were taken in flashlight mode and strobing mode with the latest BSSL test version. The Signal Test Unit was run as flashlight mode and the effects of the lights in different intensity on the human vision were tested. We tested these effects of light patterns on ourselves. The distance of the BSSL that is planned to be used is maximum 20 m. The light spread which is the width of the light when it hits the flat surface and the coverage area which is the size of the circular area that the light illuminates on the flat surface were calculated from this distance; the result is given in Fig. 56. From this maximum level, lux and lumen values were measured for each color in flashlight mode and the values are given in the Table 4.



**Figure 50** The distribution of light on a flat surface

**Table 4** Lux and Lumen values of BSSL with 5 degrees lens at 20 meters

<b>Beam (view) Angle: 5 degrees Distance: 20 meters</b>		
<b>COLOURS</b>	<b>LUMENS</b>	<b>LUX</b>
<b>RED</b>	105	43,.9
<b>GREEN</b>	186.6	78.01
<b>BLUE</b>	41.4	17.31
<b>WHITE/AMBER</b>	242	101.2

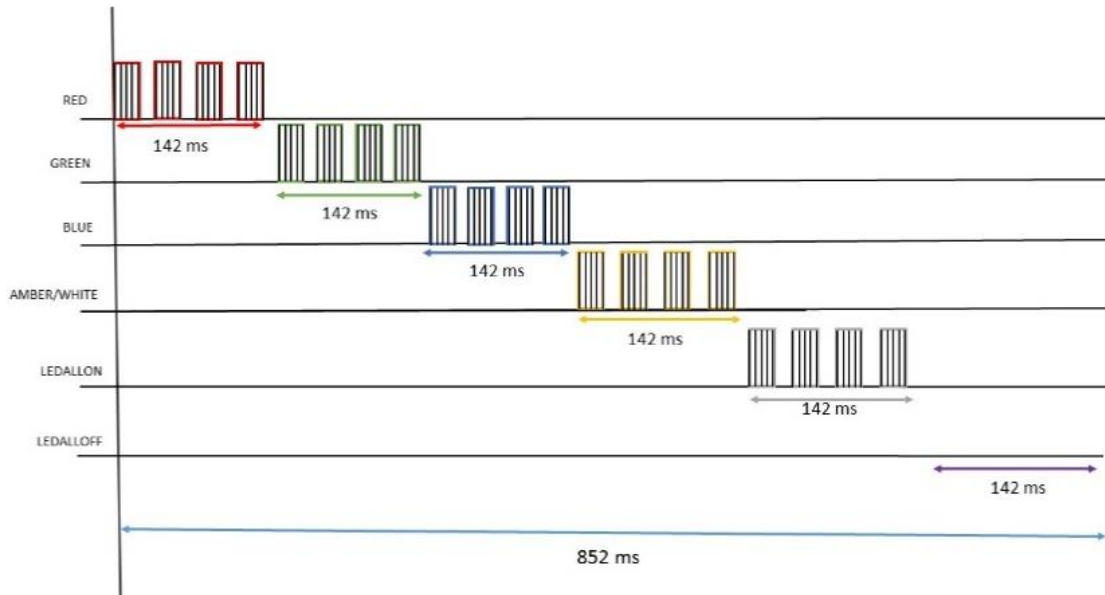
For strobing mode, the tests were performed including only red, only green, only blue and only white/amber at the range of 7-15 Hz frequency. It was observed that the desired effects were performed with these frequency values and the required conditions for the officer to prevent the human target for a short time was fulfilled.

As a result of the first reactions in the tests, we observed that red light is more effective in terms of affecting the vision of the human target compared to the other colors, and also its effects lasted longer. Furthermore, we observed that since the white light provides more luminous intensity than the other colors, it may cause short-term visual impairment on the human target.

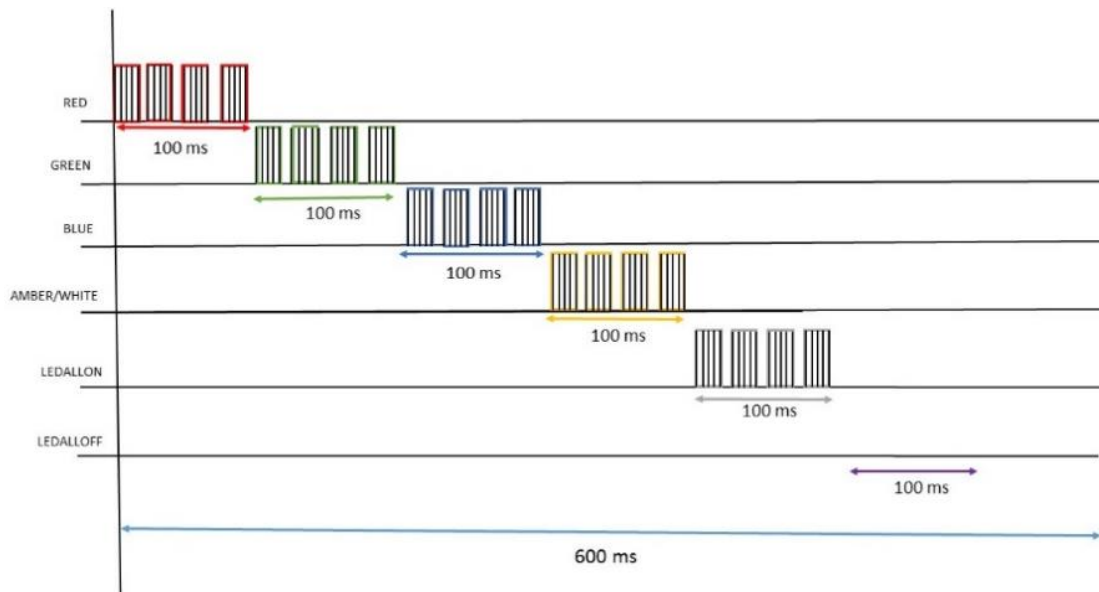
The light pulses in different colors selected randomly were tested in different frequency ranges and the effects on the subject were observed. Various time and color patterns of the light pulses, which are repeated in an infinite loop periodically were generated to determine the effective patterns.

During the tests, we tested nearly ten thousand patterns of light pulses. These tests lasted 18 months and they were compared and verified with theoretical and practical information. We used ourselves as samples for the tests of the patterns of light pulses. For the frequency of the tests, we got a temporary value from the analog to digital converter modules and calculated the waiting period and the testing frequency.

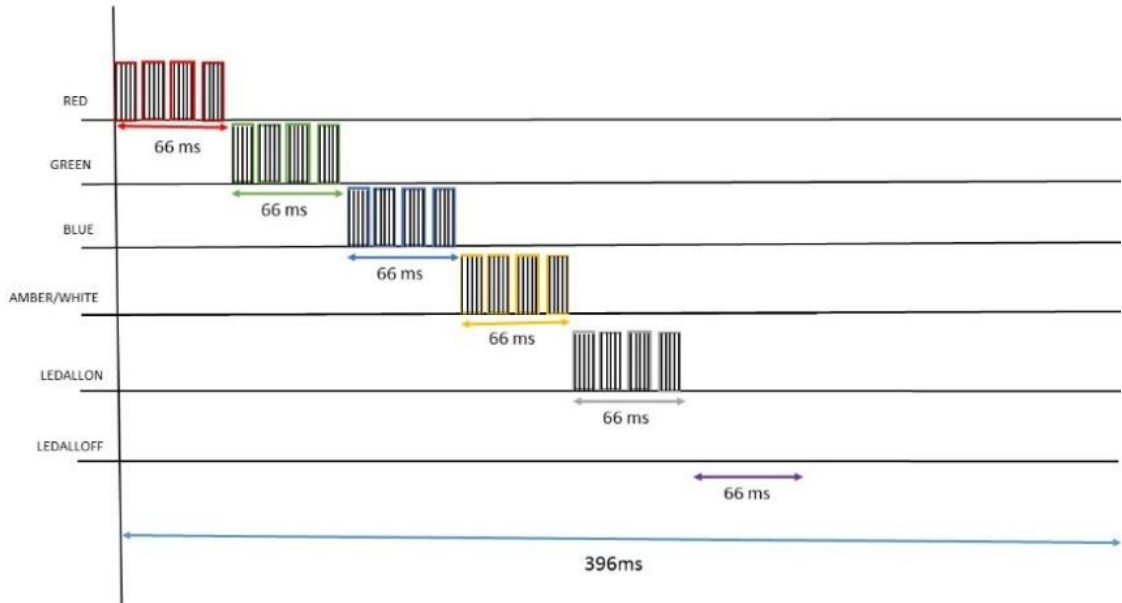
Tests were performed at the frequencies between 7 – 15 Hz. Here the frequency is the inverse of the period between the light pulses in the pattern. After testing various patterns of light pulses we identified the most effective pattern. These light pulses in Figs. 57 - 60 are actually modulating the carrier frequency of the light pulses set by the LED drivers given in Fig. 51, and Fig. 52 (the PWM frequency of the LED Driver).



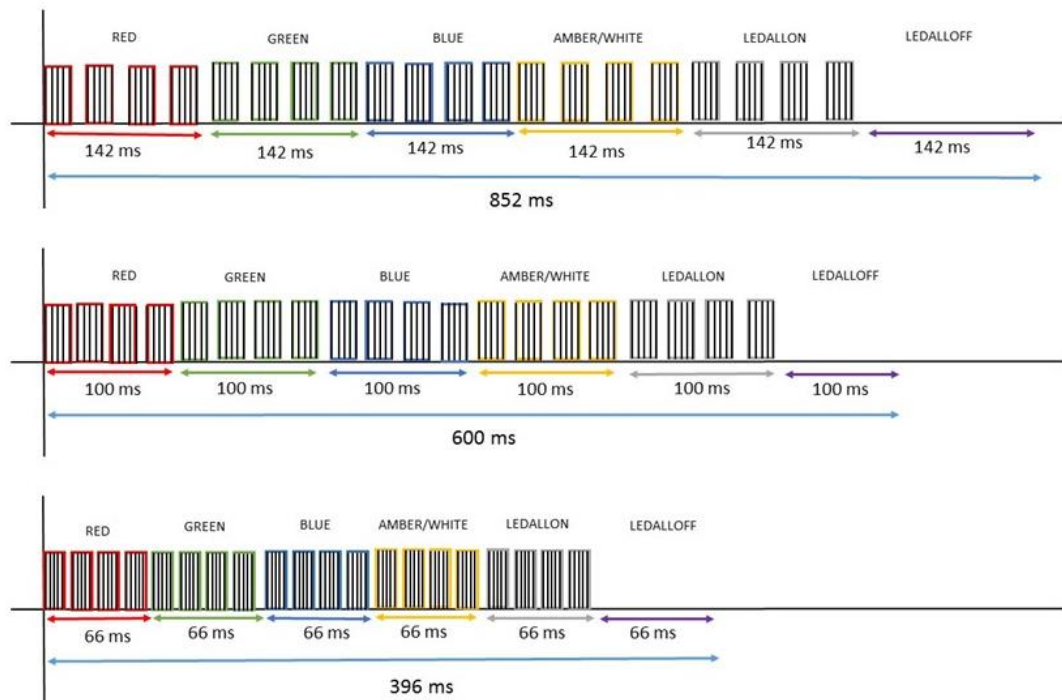
**Figure 51** Light pulses of BSSL at 7 Hz



**Figure 52** Light pulses of BSSL at 10 Hz



**Figure 53** Light pulses of BSSL at 15 Hz



**Figure 54** Light Pulses of BSSL at most effective frequencies

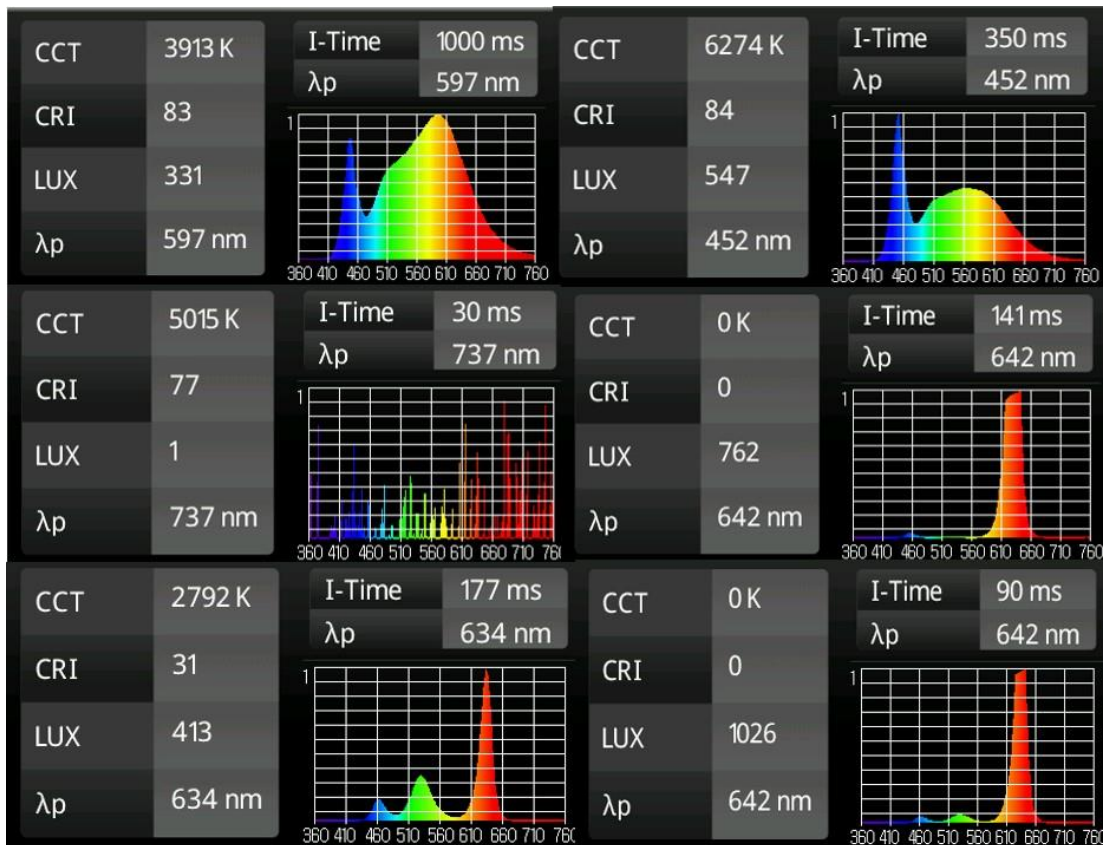
**Table 5** Most effective patterns' frequency and period values

<b>Test At 7 Hz</b>	<b>Test At 10 Hz</b>	<b>Test At 15 Hz</b>
RED for 142 milliseconds	RED for 100 milliseconds	RED for 66 milliseconds
GREEN for 142 milliseconds	GREEN for 100 milliseconds	GREEN for 66 milliseconds
BLUE for 142 milliseconds	BLUE for 100 milliseconds	BLUE for 66 milliseconds
AMBER/WHITE for 142 milliseconds	AMBER for 100 milliseconds	AMBER for 66 milliseconds
WHITE (ALL-ON) for 142 milliseconds	WHITE (ALL-ON) for 100 milliseconds	WHITE (ALL-ON) for 66 milliseconds
DARK (ALL-OFF) for 142 milliseconds	DARK (ALL-OFF) for 100 milliseconds	DARK (ALL-OFF) for 66 milliseconds

Along with the results obtained in the recent tests, the system led to the situations such as temporary visual impairment and loss in balance etc. for a few minutes with the identified light intensity, frequency and synchronicity. This period can vary from person to person. The reason of the symptoms like temporary visual impairment and loss in balance is the prevention of the focus of brain by different signals sent to the brain and glare that appears in the eye. No blackout was detected during the tests.

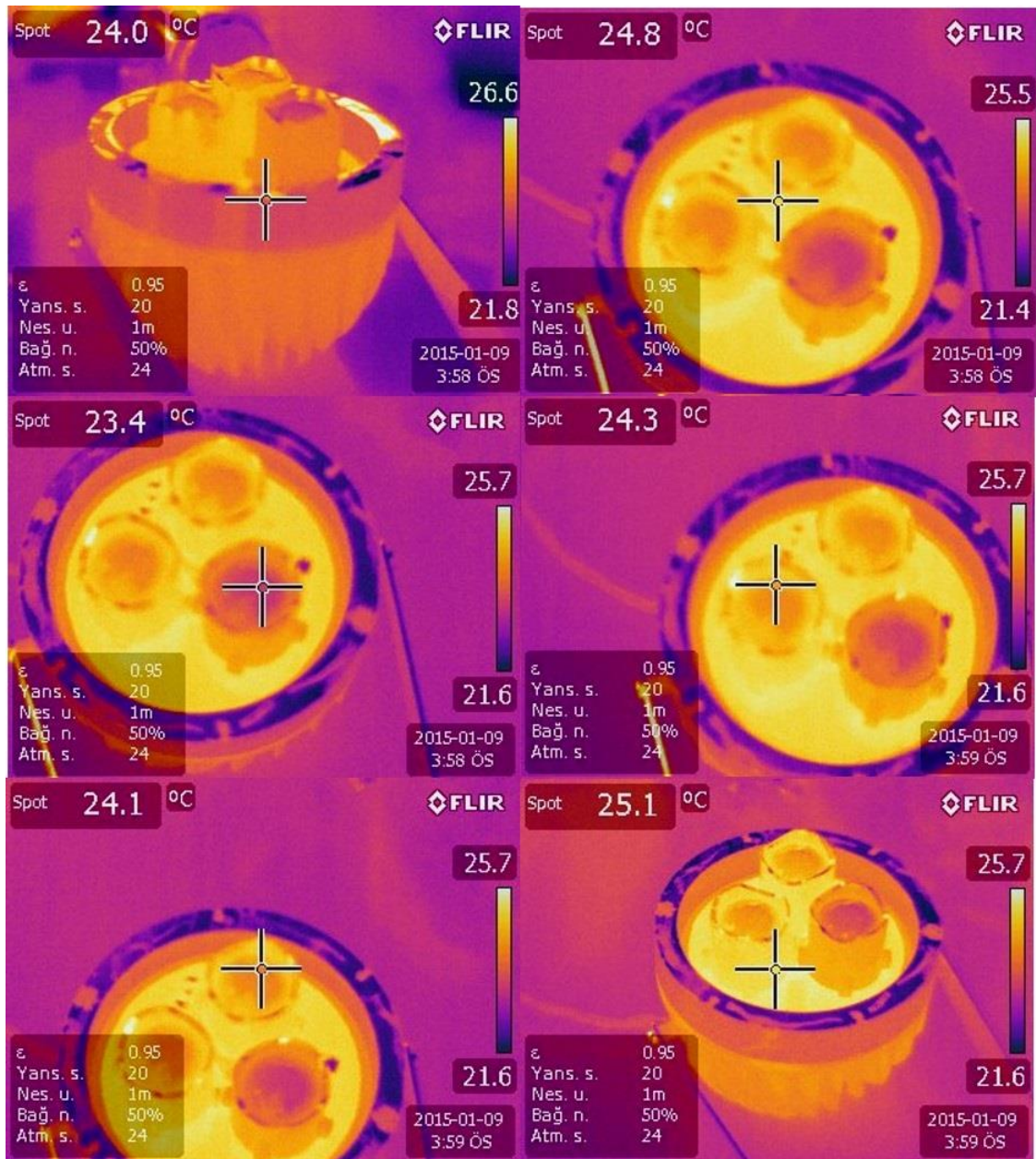
The BSSL emits pulses at different frequencies, thus in the light intensity measurement tests, different spectrum values at different wavelengths were obtained. Light intensity (lux), wavelength ( $\lambda_p$ ), color temperature (CCT) and color rendering index (CRI) values are provided in Fig. 61. These results were taken from UPRTEK MK350 spectrometer.





**Figure 55** Lighting tests of BSSL

Thermal tests of the BSSL were performed with an FLIR E-60 thermal camera and it took for 5 hours at the ambient temperature of 25 °C. The results of the measurements are given in Fig 62.



**Figure 56** Thermal tests of the BSSL

Optimal heat distribution is the key to the LED performance. An improper heat distribution causes the lifetime of the LED to get shorter and the color of the LED to change. An LED is destroyed when the junction temperature gets higher than 125°C. As seen in Fig. 62 even running continuously for 5 hours in the temperature tests, the average temperature was recorded as not higher than 25 °C.

## CHAPTER 5

### 5. CONCLUSIONS and FUTURE WORKS

In this thesis, we designed and developed a prototype of a non-lethal system using light emitting diodes (LEDs) as the light source. The system, which is called a Blocker Security System with LEDs (BSSL), sends a light beam whose color and light intensity are changed in time (spectrally, temporally) according with certain pre-programmed patterns. It was observed in the literature that these changes in light patterns cause headache, nausea, dizziness and visual defects on people who are exposed to them. These effects are observed when the change in light pattern from the LEDs is fast enough so that human's brain could not process properly the information transmitted, and therefore, it cannot decode the changes in the rate they come. In the thesis, experiments are made, and measurements are performed by using the designed and developed Blocker Security System's with LEDs (BSSL) prototype, and assessments of the experimental data have been performed to find the most effective patterns of the light. We searched the patterns that cause the desired effects on the human and tried to find the best pattern.

The subsystems of the BSSL, mainly the LEDs, the optical system that guides the light beams from the LEDs, the cooling system, the battery system, the body, and the LED drivers that generate the required light patterns were investigated. We focused mostly on the drivers that not only provide the necessary forward currents to the LEDs, but also generate the lighting patterns required from them. In doing this, we developed the embedded software required to form the lighting patterns through the driver.

To generate light in the desired intensity and color patterns in the BSSL we used 3 LED chips, each including 4 individual LEDs on a single semiconductor chip. Each LED chip has 4 LEDs of red, green, blue and white colors. To drive the LEDs we used commercially available buck type switch mode power supplies (SMPS). An SMPS drives the 4 LEDs of different color in 3 chips, which are connected in series. The light

patterns were obtained by using an embedded software running in a PIC. We used MOSFETs to switch the LEDs in accordance with the patterns generated by the PIC.

The BSSL as an integrated lamp was designed to have two modes. These modes are flashlight mode and strobing mode. When switched into flashlight mode the BSSL becomes a simple lantern for providing white light. When switched into strobing mode, the BSSL generates periodic patterns of light of alternating colors of alternating intensities of light in time. We observed that the most effective patterns of light that can cause reduced visibility, destruction, disruption, disorientation on the people were in the frequency range of 7-15 Hz.

We performed the tests against the patterns on ourselves. The patterns we developed are therefore the most effective on us only. We do not know whether this patterns would have the same effects on other people, and generally valid. Since the patterns are simply generated by coding in the software of the BSSL only, it is easy to construct different patterns and test and observe the results. However, in performing the test we need human samples for which we need permissions from the authorities. If samples are available, the prototype BSSL is a very useful tool that can be used practically in generating the patterns.

For the future work in this project one needs improvement in two aspects. We could not use an eye doctor (ophthalmologist) and a brain doctor or neurologist to consult in developing the proper light patterns. We searched the literature and try to understand the effects of the light patterns on the eye and brain functions of a human being. Therefore, firstly in the future, a team of consultants having these areas of expertise should be included in the team to understand and evaluate effects of the light patterns on the human body. Secondly, sufficient number of human samples should be used in testing the efficiency of the light patterns to verify the BSSL to incapacitate the people as desired.

## REFERENCES

1. **Borer D. A., (2003)**, *“Inverse Engagement: Lessons from U.S.-Iraq Relations, 1982–1990”*, U.S. Army Professional Writing Collection. U.S. Army.
2. **Department of Homeland Security: Science and Technology Directorate, (2007)**, *“Enough to Make You Sick”*, 2007 S&T Snapshots.
3. **Hall M. and Moreno E., (2007)**, *“Is this a real-life ‘light saber’?”*, USA Today online
4. **FOX News Network, LLC, (2007)**, *“Flashlight Weapon Makes Targets Throw Up,”* Fox News online
5. **Patel-Predd P., (2007)**, *“The Incapacitating Flashlight: DHS Is Developing an LED Flashlight That Makes Culprits Vomit”*, ABC News: Technology & Science (ABC News Internet Ventures)
6. **Altman L., (2007)**, *“Torrance firm sees the nonlethal ‘light ’*, Los Angeles Newspaper Group
7. **Rubtsov V., (2007)**, *“Incapacitating flashing light apparatus and method”*, US7180426 B2, USA
8. **Rubtsov V., (2009)**, *“LED-based incapacitating apparatus and method”*, US 7500763 B2, USA
9. **Mindalive**, [https://www.mindalive.com/2\\_0/ch6.pdf](https://www.mindalive.com/2_0/ch6.pdf) , (Data Download Date: 22.11.2013)

10. **Ryer D. A., (1997)**, Light Measurements Handbook, International Light Inc.
- 11.. **Williamson S J and Cummins H Z, (1983)**, Light and Color in Nature and Art, John Wiley & Sons Inc, p. 173
12. <http://hyperphysics.phyastr.gsu.edu/hbase/vision/candle.html#c1>.
13. **(2005)**, “*Nomenclature and Definitions for Illuminating Engineering*”, Illuminating Engineering Society of North America
14. [http://www.osram.com/osram\\_com/news-and-knowledge/led-home/professional-knowledge/led-basics/led-history/](http://www.osram.com/osram_com/news-and-knowledge/led-home/professional-knowledge/led-basics/led-history/)
15. <http://powerelectronics.com/site-files/powerelectronics.com/files/archive/powerelectronics.com/images/high-voltage-GaN-fig-1.jpg>.
16. **Hook J. R. and Hall. H. E., (1991)**, Solid State Physics, 2nd Ed, Wiley
17. **Musayev E., (2005)**, “*Semiconductor Light Sources Connection and Biasing Methods*”, Journal of Engineering and Architecture, Uludağ University, vol. 10, no. 2, pp. 63-78
18. **E. Musayev, (2004)**, “*Investigation of Homogeneity of the LED Light, Illumination*”, Electronic, Automation, Energy, Journal of Machine and Control Systems, no.118, pp. 190-195

19. **Winder S., (2008),** “*Power Supplies for LED Driving*”, Elsevier Science, Boston, MA, USA
20. **Saleh B. E. A. and Teich M. C., (2007),** “Fundamentals of Photonics”, Wiley-Interscience, Hoboken, NJ, USA
21. **(2008),** Edixeon Dx, Ex Series LEDs, “Application Notes”, Edison Opto Corporation, USA
22. <http://www.lificonsortium.org/>
23. **Singh S. C.,** “*Basics Of Light Emitting Diodes, Characterizations And Applications*”, Department of Physics University of Allahabad, Allahabad-211002, India
24. <http://www.vtsmexico.com/tecnologia-vled.php>
25. [http://en.wikipedia.org/wiki/Light-emitting\\_diode](http://en.wikipedia.org/wiki/Light-emitting_diode)
26. **(2006),** “*An incredible year for Solid-State Lighting – the future is bright for LED*”, Mondoarc issue 34
27. **Stevenson R., (2009),** “*The LED’s Dark Secret*”, University of Cambridge, p.22
28. **Nguyen T., (2011),** “*Why LED light bulbs cost so much (and how that’s about to change)*”, [www.zdnet.com](http://www.zdnet.com) Article

29. **Çil, C. Z., (2014),** “*Işık Yayan Diyotlar (LED’LER) ve Aydınlatmada Kullanımı*”, 6. LED ve LED Aydınlatma Konferansı
30. **Zhang J. H., (2013),** “*Basic concepts of linear regulator and switching mode power supplies*”, Linear Technology, Application Note 140
31. **Liao A, (2014),** “*LEDs: Understanding Optical Performance*”, Architectural Lighting
32. **Soraa, (2014),** “*Releases full-visible-spectrum Vivid 2 MR16 LED lamps suitable for enclosed light fixtures*”
33. **Lenau T., (2012),** “*Reflections from nature*”
34. “*Reflectors – Lenses*”, LAMP 83 Lighting Company Inc.
35. “*TIR Lens Guide*”, LEDIL Company Inc.
36. **Fraen, (2014),** “*Develops optics with multi-TIR nested lens technology for COB LEDs*”
37. **Doe, (2014),** “*CALIPER Report 22: LED MR16 Lamps*”, Office of Energy Efficiency & Renewable Energy, Building Technologies Program
38. **Kuntze T., (2009),** “*All Facts for Choosing LED Optics Correctly*”, LED Professional



39. **Domingo J., (2011)**, *“Ensuring Optimal High Power LED Performance with Thermal Management”*, Lumex
40. **Tarzwel R., (2009)**, *“The Bleeding Edge: Printed Electronics Meets LED”*
41. **Martel A., (2007)**, *“Light Modulation, a new way of looking at lighting”*, Professional Lighting Design Magazine, vol. 57
42. **Baysal L., Bebek N. and Baykan B., (2014)**, *“Photosensitivity and Reflex Epilepsies”*, Epilepsy vol. 20 (Annex 1), pp. 23-31
43. **Daab R., (1993)**, *“A Brief Introduction to Light and Sound”*, the Voyager XL User Guide
44. **(2006)**, Laser Safety Guidelines, University of Purdue
45. **Rockwell R. James, Ertle W. J. and Moss C. E., (2003)**, *“Safety Recommendations of Laser Pointers”*, Rockwell Laser Industries
46. **Klinghardt D., (2003)**, *“The Neurophysiology of Light, The Five Pathways”*, Journal of Optometric Phototherapy, pp. 35-40
47. **(2008)**, *“Bringing you a prosperous future where energy is clean, abundant, reliable and affordable”* U.S. Department of Energy, Energy Efficiency and Renewable Energy
48. **(2013)**, *“Federal 5050 Series Datasheet”*, Edison Opto Corporation

49. **E. F. Schubert**, "*Human eye sensitivity and photometric quantities*", p.282
50. **(2004)**, "HV9910 Datasheet, Universal High Brightness LED Driver", Supertex Inc.
51. [https://en.wikipedia.org/wiki/Photometry\\_\(optics\)](https://en.wikipedia.org/wiki/Photometry_(optics))
52. **Grather M.**, "*Solid State Lighting Solid State Lighting The Current State of Standards*", Luminaire Testing Laboratory, Inc., Testing Procedures Committee of the IESNA
53. "*Standards Development For Solid-State Lighting*", U.S. Department of Energy's Office of Energy Efficiency & Renewable Energy

## APPENDICES

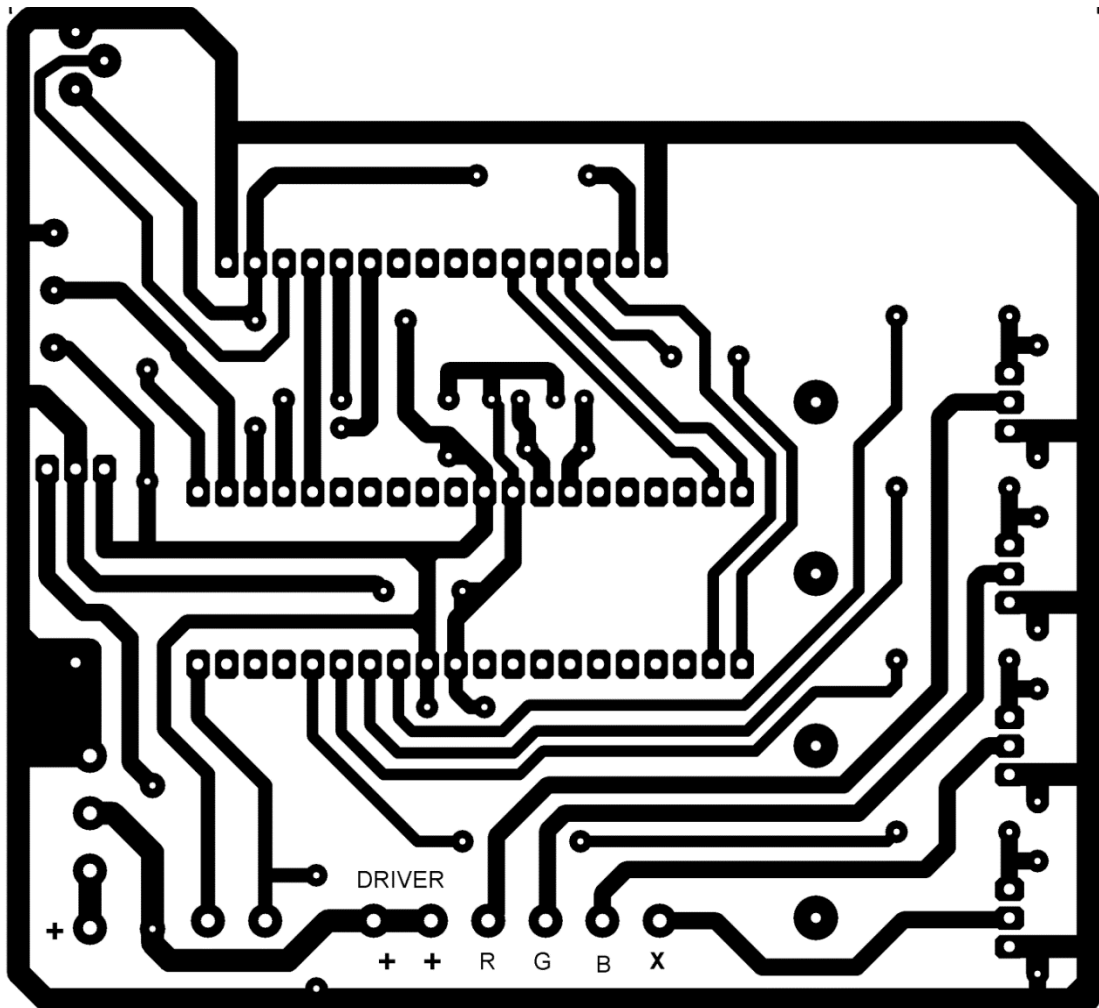
### A. PHOTOMETRIC UNITS

Light is defined with photometric units which are introduced in the following table [51].

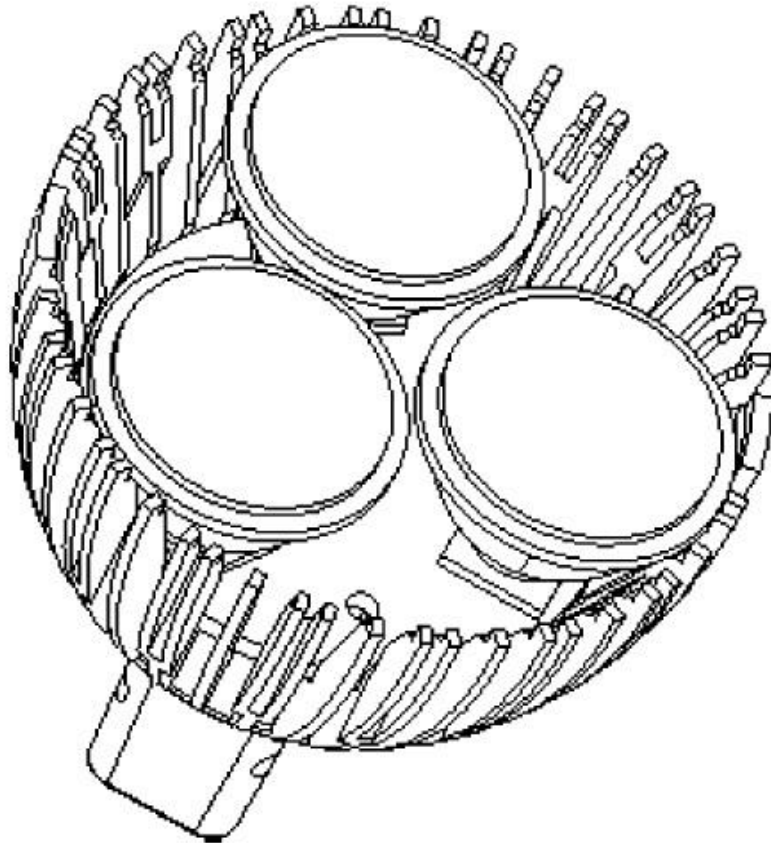
Quantity	Symbol	SI Unit	Symbol
<b>Luminous flux</b>	$\Phi_v$	lumen (cd*sr)	lm
<b>Luminous energy</b>	$Q_v$	lumen second	lm*s
<b>Luminous intensity</b>	$I_v$	candela (=lm/sr)	cd
<b>Luminance</b>	$L_v$	candela per square meter	cd/m <sup>2</sup>
<b>Illuminance</b>	$E_v$	lux (=lm/m <sup>2</sup> )	lx
<b>Luminous exposure</b>	$H_v$	lux second	lx*s
<b>Luminous emittance</b>	$M_v$	lux (=lm/m <sup>2</sup> )	I*x
<b>Luminous efficacy</b>	$\eta$	lumen per watt	lm/W
<b>Luminous efficiency</b>	$V$	non-unit (W/W)	



- PRINTED CIRCUIT BOARD



### C. 3D MECHANICAL STRUCTURE OF BSSL



#### D. SOFTWARE OF BSSL SIGNAL UNIT

```
// by Burcu YAKIŞIR GİRĞİN-BSSL
#include "PIC_16f877a.h "
#include "flex_lcd.c"
#fuses HS,NOWDT,NOPROTECT
#usedelay(clock=20M)
#define OnlyRED 0x01
#define OnlyGREEN 0x02
#define OnlyBLUE 0x04
#define OnlyX 0x08
#define AllTogether 0x0F
int16 ms=0;
#int_timer2
void isr_timer2(void) {
ms++;
}

intADCreturner(){
unsignedintdeger;
set_adc_channel(0);
delay_us(10);
deger = read_adc();
returndeger;
}

voidLedIndividual(intdelayValue){
output_b(OnlyRED);
delay_ms(delayValue);
output_b(OnlyGREEN);
delay_ms(delayValue);
```

```

output_b(OnlyBLUE);
delay_ms(delayValue);
output_b(OnlyX);
delay_ms(delayValue);
}
voidLedAllFlashing(intdelayValue){
output_b(AllTogether);
delay_ms(delayValue);
output_b(0x00);
delay_ms(delayValue);
}
voidLedAllOn(){
output_b(0x0F);
}
voidLedAllOff(){
output_b(0x00);
}
intPeriodToFrequency(intperiod){
return (int)1000/period;
}
void main()
{

setup_adc_ports(AN0);
setup_adc(ADC_CLOCK_DIV_2);
setup_psp(PSP_DISABLED);
setup_spi(SPI_SS_DISABLED);
    setup_timer_0(RTCC_INTERNAL|RTCC_DIV_1);
    setup_timer_1(T1_DISABLED);

```



```

    setup_timer_2(T2_DIV_BY_4,79,16);    //setup timer2 to interrupt every 1ms
    //using 20Mhz clock
    setup_comparator(NC_NC_NC_NC);
    setup_vref(FALSE);

    enable_interrupts(INT_TIMER2); //enable timer2 interrupt
    enable_interrupts(GLOBAL);    //enable all interrupts (else timer2 won't happen)

    lcd_init();
    set_tris_c(0x00);
    output_c(0x00);
    set_tris_b(0x80);
    printf(lcd_putc, "\f LCD Test\n1234567890");
    delay_ms(1000);
    printf(lcd_putc, "\f");
    unsigned int period = 100;
    float sayac = 0;
    while(1){
        if(input(PIN_B7)){
            if(ms > 1000){
                ms = 0;
                period = ADC_returner();
                sayac = 1000/period;
                printf(lcd_putc, "\f Frekans: %f", sayac);
            }
            LedIndividual(period);
            LedAllFlashing(period);
        }
        else{

```

```
LedAllOn();  
  }  
}  
  
//TODO: User Code  
  
}
```

## E. CURRICULUM VITAE

### PERSONAL INFORMATION

**Surname, Name:** Yakışır Girgin, Burcu

**Date and Place of Birth:** 08 Dec 1986, Erzincan

**Marital Status:** Married

**Phone:** +90 506 201 64 98

**Email:** bygirgin@ankara.edu.tr

### EDUCATION

Degree	Institution	Year of Graduation
M.Sc.	Çankaya Uni., Electronic and Communication Engineering	2015
M.Sc.	Gazi Uni, Electrical and Electronic Engineering	2011
B.Sc.	Çankaya Uni., Electronic and Communication Engineering	2010
High School	Erzincan Anatolian High School	2004

### WORK EXPERIENCE

Year	Place	Enrollment
2015 April - Present	Ankara Uni, Nallıhan Vocational School	Assistant Director
2014- Present	Ankara Uni, Nallıhan Vocational School	Lecturer
2013 - 2014	YK Group	R&D Engineer
20011-2013	BY Technology	R&D Engineer

## **FOREIGN LANGUAGES**

Advanced English, Beginner Italian

## **PUBLICATIONS**

1. Designing an off-road working lamp with LEDs, C.Z. Çil and B. Yakışır, Istanbul University-Journal of Electrical & Electronics Engineering (IU-JEE), 11(1), 1291-1298, 2011
2. Designing a LED Driver Circuit for off-road working lamp, B. Yakışır, C. Z. Çil, ELECO 2010 Conference on Electrical & Electronics & Computer Engineering, 2-5 December 2010
3. Designing an off-road working lamp with LEDs, B. Yakışır, C. Z. Çil, Y. Baykal, MTS3 Çankaya Uni, 29-30 April 2010

## **PROJECTS**

1. Blocker Security System with LEDs, Republic of Turkey Small and Medium Enterprises Development Organization, R&D, Innovation and Industrial Application Support
2. Designing an off-road working lamp with LEDs, Project Number: 0641.TGSD.2011, Ministry of Science, Industry and Technology, 2011.

## **HONOURS AND AWARDS**

1. Startup Mentor Turkey 2014, Mentor Support
2. Prof. Dr. Nusret Yükseler Best Student Paper Award
3. Technoprenurship Capital Support 2011, Ministry of Science, Industry and Technology
4. Scholarship for MSc, Çankaya University
5. Graduate Honor Student, Çankaya University

