



**INTERMODAL FREIGHT TRANSPORTATION IN HUMANITARIAN
LOGISTICS**

HASAN KAVLAK

JANUARY 2016

To my mother...

**INTERMODAL FREIGHT TRANSPORTATION IN HUMANITARIAN
LOGISTICS**

**A THESIS SUBMITTED TO
THE GRADUATE SCHOOL OF NATURAL AND APPLIED
SCIENCES OF
ÇANKAYA UNIVERSITY**

**BY
HASAN KAVLAK**

**IN PARTIAL FULFILLMENT OF THE REQUIREMENTS FOR THE
DEGREE OF
MASTER OF SCIENCE
IN
THE DEPARTMENT OF
INDUSTRIAL ENGINEERING**

FEBRUARY 2016

Title of the Thesis: **Intermodal Freight Transportation in Humanitarian Logistics**

Submitted by **Hasan KAVLAK**

Approval of the Graduate School of Natural and Applied Sciences, Çankaya University.



Prof. Dr. Halil Tanyer EYYUBOĞLU
Director

I certify that this thesis satisfies all the requirements as a thesis for the degree of Master of Science.

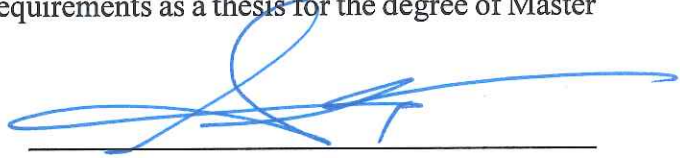

Assoc. Prof. Dr. Ferda Can ÇETİNKAYA
Head of Department

This is to certify that we have read this thesis and that in our opinion it is fully adequate, in scope and quality, as a thesis for the degree of Master of Science.



Assist. Prof. Dr. M. Alp ERTEM
Supervisor

Examination Date: 03.02.2016
Examining Committee Members

Assoc. Prof. Dr. Ferda Can ÇETİNKAYA

Assoc. Prof. Dr. Serhan DURAN

Assist. Prof. Dr. Mustafa Alp ERTEM







STATEMENT OF NON-PLAGIARISM PAGE

I hereby declare that all information in this document has been obtained and presented in accordance with academic rules and ethical conduct. I also declare that, as required by these rules and conduct, I have fully cited and referenced all material and results that are not original to this work.

Name, Last Name : Hasan KAVLAK

Signature :

Date :

03.02.2016

ABSTRACT

INTERMODAL FREIGHT TRANSPORTATION IN HUMANITARIAN LOGISTICS

KAVLAK, Hasan

Department of Industrial Engineering

Supervisor: Assist. Prof. Dr. Mustafa Alp ERTEM

February 2016, 148 pages

Intermodal freight transportation is used heavily in commercial logistics around the world. On the other hand, in humanitarian logistics, it is not considered as the primary solution. Transportation resilience during response phase is an important performance criterion for humanitarian logistics and it mostly depends on the availability of the modes used for transporting relief items. Previous studies brought multi-modal or multi-vehicle transportation to forefront. Intermodal freight transportation is not focused from a perspective of resilience in humanitarian logistics. This study aims to highlight the differences between intermodal transportation and multi-modal transportation and to present a resilient transportation system without handling of relief items. Two integer programming models are developed based on a time-space network by considering route and vehicle availabilities changing dynamically over a specified time horizon. In these models, different types of vehicles and different capacities of unit loading device and intermodal transportation unit are considered, namely, truck

(highway), freight train (railway), vessel (seaway), plane (airway) and helicopter (airway).

This study proposes a unit loading device for humanitarian logistics that is compatible with different transportation modes. The first model includes an integer variable representation for vehicle fleets of different transportation modes. It can be concluded that the second model includes an index representation of individual vehicles for different transportation modes. The first mathematical model with integer variable representation of vehicle fleets is more effective than the second one. Five real life scenarios are fed into these mathematical models and the results are compared. The results of the experimental study show that intermodal transportation provides better humanitarian response in terms of resilience.

Keywords: Intermodal freight transportation, humanitarian logistics, resilience of lifeline, integer programming, time-space network, unit loading device, intermodal transportation unit

ÖZ

İNSANİ YARDIM LOJİSTİĞİNDE İNTERMODAL YÜK TAŞIMACILIĞI

KAVLAK, Hasan

Endüstri Mühendisliği Anabilim Dalı

Tez Yöneticisi: Yrd. Doç. Dr. Mustafa Alp ERTEM

Şubat 2016, 148 sayfa

Intermodal yük taşımacılığı dünya genelinde ağırlıklı olarak ticari yük taşımacılığı alanında kullanılmakta olup, insani yardım lojistiği için birincil çözüm olarak düşünülmemektedir. Afet sonrası müdahale aşamasındaki taşıma faaliyetlerinin çabuk toparlanabilirliği, insani yardım lojistiği açısından önemli bir performans ölçütüdür ve çoğunlukla insani yardım malzemelerinin transferinde kullanılacak modların mevcudiyetine bağlıdır. Önceki çalışmalar çok modlu veya çok araçlı çalışmaları öne çıkarırken intermodal yük taşımacılığının insani yardım lojistiğine kazandırdığı esnekliğe odaklanmamıştır. Bu çalışmada, intermodal yük taşımacılığı ve çok modlu taşımacılık arasındaki farklılıkları vurgulamanın yanısıra, yardım malzemelerinin elleçlenmeden transfer edilmesini sağlayacak esnek bir intermodal taşıma sistemi sunulması amaçlanmaktadır. Bu amaç doğrultusunda, zaman uzaylı ağ modeline dayanan ve belirli bir zaman ekseninde dinamik olarak değişen rota ve araç

durumlarını göz önünde bulunduran, iki farklı tamsayılı doğrusal programlama modeli geliştirilmiştir. Bu modeller, farklı araç tiplerini, birim yükleme araçlarını ve tır (karayolu), yük treni (demiryolu), gemi (denizyolu), helikopter ve uçak (havayolu) olarak belirlenmiş intermodal taşıma birimleri dikkate almaktadır. Bu çalışma, insani yardım lojistiği için farklı taşıma modlarına uygulanabilir bir yük taşıma birimi önermektedir. Geliştirilen ilk modelde farklı taşıma yöntemlerine ait araçlar tamsayılı değişken olarak tanımlanmıştır. Diğer modelde ise farklı taşıma yöntemlerine ait her bir araç ikili değişken ile gösterilmiştir. Önerilen iki matematiksel model beş farklı gerçek hayat veri seti ile test edilmiş, sonuçları belirlenen performans ölçütleri doğrultusunda karşılaştırılmıştır. Analizler sonucunda birinci modelin ikincisine göre daha etkili olduğu gösterilmiştir. Deneysel çalışmalar sonucunda, intermodal taşımacılığın, çabuk toparlanma ölçütü bakımından daha iyi bir insani yardım müdahalesi sağladığı gösterilmiştir

Anahtar Kelimeler: İntermodal Yük Taşımacılığı, İnsani Yardım Lojistiği, Yenilenebilir Hayat Yolu, Tamsayılı Doğrusal Programlama, Yük Taşıma Birimi, İntermodal Taşıma Birimi

ACKNOWLEDGEMENTS

I would like to express my sincere thanks to Assist. Prof. Dr. Alp ERTEM and Assist. Prof. Dr. Benhür SATIR for their guidance and counselling, encouragement, support and patience during this study.

I would also like to thank my committee members, Assoc. Prof. Dr. Serhan DURAN and Assoc. Prof. Dr. Ferda Can ÇETİNKAYA, for their valuable opinions and contributions to this study.

I would like to thank my dear friends Esra DURMAZ, Hale AKKOCAOĞLU, Derya AKBULUT, Şefik Can TEKİN and my colleagues at the IE department for their faithfulness, technical and morale support whenever I need.

I would also like to thank all my professors at the IE department for their motivation and tolerance.

Finally, I must express my very profound gratitude to my mother, father, sister, brother and my wife for providing me with unfailing support and continuous encouragement throughout my years of study and through the process of researching and writing this thesis. This accomplishment would not have been possible without them. Thank you.

TABLE OF CONTENTS

STATEMENT OF NON-PLAGIARISM PAGE	iii
ABSTRACT	iv
ÖZ	vi
ACKNOWLEDGEMENTS	viii
TABLE OF CONTENTS	ix
LIST OF FIGURES	xii
LIST OF TABLES	xiv
LIST OF ABBREVIATIONS	xvi
CHAPTER 1	1
INTRODUCTION	1
CHAPTER 2	6
LITERATURE REVIEW.....	6
2.1 Humanitarian Logistics and Phases of a Disaster	7
2.2 Models Developed in Humanitarian Logistics	11
2.3 Intermodal Freight Transportation and Transportation Units	20
CHAPTER 3	24
PROBLEM DEFINITION	24
3.1 Problem Definition and Transportation Network.....	24
3.2 Assumptions	31
CHAPTER 4	33
MATHEMATICAL MODEL	33

4.1 Integer Programming Model (IPM-I) with Vehicles Represented as Integer Variables.....	33
4.2 Integer Programming Model (IPM-II) with Vehicles Represented as Binary Variable	46
4.3 Single Mode Modified Integer Programming Model I (IPM-I).....	51
4.3 Complexities of The Models	52
CHAPTER 5	55
EXPERIMENTAL STUDY	55
5.1 Performance Measures	55
5.2 Scenarios	58
5.3 Data Gathering	59
5.3.1 Demand.....	59
5.3.2 Capacities.....	60
5.3.3 Costs and Route Availabilities.....	62
5.3.4 Transportation Lead Time and Time Periods	65
5.3.6 Number of Vehicles and Inventory at The Beginning	67
5.4 Experimental Sets.....	68
5.4.5 Constructing Run Sets	70
5.5 Results and Comparisons	73
5.5.1 Results of IPM-II	73
5.5.2 Results of IPM-I.....	80
5.5.3 Comparisons	85
CHAPTER 6	101
CONCLUSION.....	101
REFERENCES.....	R1
APPENDICES A.....	A1
APPENDICES B.....	A12

APPENDICES C.....	A15
CURRICULUM VITAE	A15

LIST OF FIGURES

FIGURES

Figure 1 Transportation of relief items with ULD	5
Figure 2 Classification of disasters [24].....	6
Figure 3 The schematic definition of a disaster by IFRC [44].....	7
Figure 4 Phases of disaster management. [29].....	8
Figure 5 Considering of phases in literature review.	9
Figure 6 Classification framework of Humanitarian Logistics [49].	11
Figure 7 Unit loading device AKE.....	23
Figure 8 A transshipment network for transportation of disaster relief items	25
Figure 9 A graphical representation of the network.....	26
Figure 10 Transportation routes and modes.....	27
Figure 11 An illustration of disrupted routes.	28
Figure 12 Conceptual model of the problem.....	30
Figure 13 Time horizon of problem.	31
Figure 14 AKE and AKH specifications.....	61
Figure 15 Time between two demands	70
Figure 16 User form of data constructor for integer representation.....	71
Figure 17 User form of data constructor for binary representation.....	72
Figure 18 User form of GAMS model file constructor	72
Figure 19 Period Costs of 92BV3D0T4.....	80
Figure 20 Comparison of completion time of IPM-II and IPM-I for 92 vehicles, 3 demand and starting period 4	81
Figure 21 Average period costs comparison of scenario1.	85
Figure 22 Number of vehicles used in scenario 1	86

Figure 23 Number of ITU of scenario 1.	87
Figure 24 Intermodal transportation percentages of scenario 1.	87
Figure 25 Total number of ULDs stored according to the two models and number of demand occurrence	88
Figure 26 Average fill rates of vehicles according to two models and number of demand occurrence.....	89
Figure 27 Objective function cost of IPM-I and Single mode with three demand occurrences that star at first period is 4.....	90
Figure 28 Completion time of IPM-I and Single mode IPM-I	91
Figure 29 Average period costs of IPM-I and Single mode IPM-I.....	92
Figure 30 Number of vehicle used of IPM-I and Single mode IPM-I.	92
Figure 31 Number of ITU used of IPM-I and Single mode IPM-I.	93
Figure 32 Average fill rates of IPM-I and Single mode IPM-I.....	94
Figure 33 Total number of ULDs stored according to the two models and number of demand occurrence.	95
Figure 34 Intermodal transportation percentages according to the models.	95
Figure 35 Intermodal transportation percentages according to the models.	96
Figure 36 Completion time of scenario 2 according to the models.	96
Figure 37 Intermodal transportation percentages of instances scenario 3.	97
Figure 38 Objective function value of IPM-I and single mode IPM-II in scenario 3.....	97
Figure 39 Completion times of IPM-I and single mode IPM-II in scenario 3.....	98

LIST OF TABLES

TABLES

Table 1 Natural Disasters in Turkey Between 1900 and 2015.....	3
Table 2 Operations in the phases of disaster management [24].....	8
Table 3 Number of study considers phases.....	9
Table 4 Differences between Commercial SCM and Humanitarian SCM [48].....	10
Table 5 Number and percentage of model types studied in disaster management. ..	12
Table 6 Number of transportation modes considered	12
Table 7 Number of models used transportation methods	13
Table 8 Models for relief delivery and casualty transport (Enhanced from [37]).	14
Table 9: Classifications of proposed models and related studies.....	19
Table 10 Complexities of IPM-I and IPM-II according to decision variables.....	53
Table 10 Complexities of IPM-I and IPM-II according to decision variables.....	54
Table 12 Cities of scenarios	58
Table 13 DEMP and TCDD logistic warehouses of cities.....	59
Table 14 Disaster areas and their demand determinations.....	60
Table 15 Specifications of ULDs and ITU	60
Table 16 Capacities of warehouses	62
Table 17 Transportation costs according to routes and transportation modes.....	63
Table 18 Inventory holding cost of cities.....	64
Table 19 Mode changing cost	65
Table 20 Lead times of transportation modes according to cities.....	66
Table 21 Allocation of 40 vehicles	67
Table 22 Allocation of 92 vehicles	68
Table 23 Run sets of IPM-I, IPM-II and Single model IPM-I.....	69

Table 24 Cost and completion time results of scenario 3 with 3 demand, 40 binary vehicle	73
Table 25 Cost and completion time results of scenario 3 with 3 demand, 40 binary vehicle	74
Table 26 Amount of flow items from suppliers for run set 92BV3D0T4.....	75
Table 27 Amount of flow items from warehouses for run set 92BV3D0T4	76
Table 28 Number of inventory carried by warehouses in 92BV3D0T4.	76
Table 29 Availabilities of vehicles at suppliers in 92BV3D0T4.	77
Table 30 Availabilities of vehicles at warehouses in 92BV3D0T4.	77
Table 31 Warehouse usage in 92BV3D0T4.....	78
Table 32 Mode changing in 92BV3D0T4.....	78
Table 33 Number of ITU used to transport ULDs from suppliers to warehouses in 92BV3D0T4.....	79
Table 34 Number of ULD used from supplier to warehouse in 92BV3D0T4.....	79
Table 35 Solution of mode changing for 92IV3D0T4.....	82
Table 36 Availabilities of transportation mode for 412 vehicles and demand starts at period 16 with 3 demands	83
Table 37 Optimal solutions of scenario 5	83
Table 38 Solutions of mode changing for 92SMV3D0T4.....	84

LIST OF ABBREVIATIONS

IFRC	International Federation of Red Cross and Red Crescent Societies
EM-DAT	Emergency Events Database
JICA	Japan International Cooperation Agency
DEMP	Turkish Disaster and Emergency Management Presidency
TCDD	Turkish State Railways
ULD	Unit Loading Device
ITU	Intermodal Transportation Unit
IP	Integer Programming
IFT	Intermodal Freight Transportation
DNF	Dynamic Network Flow Model
SCM	Supply Chain Management

CHAPTER 1

INTRODUCTION

The world has faced many disasters either caused by natural processes or man-made reasons for millions of years. Many organisms and men died during the disasters and people have developed different ways as the day goes on. In the literature, there are many definitions for a disaster. The International Federation of Red Cross and Red Crescent Societies (IFRC) define the disaster as “a sudden, calamitous event that seriously disrupts the functioning of a community or society and causes human, material, and economic or environmental losses that exceed the community’s or society’s ability to cope using its own resources” [1]. As for that Emergency Events Database (EM-DAT), the disaster is defined as “a situation or event, which overwhelms local capacity, necessitating a request to national or international level for external assistance” [2].

Throughout history, mankind have faced with natural disasters such as hurricanes, earthquakes or poverty and in the early ages, they protected themselves and the families in the caves. As the time went by, the civilizations started and evolved to today’s lives. However, because of rapid population growth, people had to live in poorly constructed buildings, geologically unsafe places or in terror-prone areas. Due to these unsafe conditions, men established several pre- and post-disaster operations, which have important roles in saving people’s lives of and transporting relief items to the disaster areas [3]. For these reasons, many studies have been done to save lives after disasters. Since human life is the most important concern, these studies have begun to emerge and increase in the last decade. Therefore, a new research area, humanitarian logistics, was born.

Kopczak and Thomas defined humanitarian logistics as

“the process of planning, implementing and controlling the efficient, cost-effective flow and storage of goods and materials, as well as related information, from the point of origin to the point of consumption for **the purpose of alleviating the suffering of vulnerable people**” [4].

In this study, we developed two mathematical models using intermodal freight transportation (IFT) for transporting relief items to beneficiaries on time and without interruption. Providing timely and continuous aid to beneficiaries is only possible with resilient transportation means. Resilience, a multidisciplinary concept which is widely studied in psychology, ecology and economy, is a key subject on daily life as well as humanitarian logistics [5]. In some related fields with this study such as emergency management, sustainable development and supply chain risk management, the term resilience is of interest. Ponomarow and Holcomb defined supply chain resilience as “the adaptive capability of the supply chain to prepare for unexpected events, respond to disruptions, and recover from them by maintaining continuity of operations at the desired level of connectedness and control over structure and function” [6]. In another definition, resilience is defined as a tool for supply chain systems to decrease disruptions, their affects and the time needed to recover disrupted operations [7]. Also, resilience is defined as a strategic tool by Chen and Miller-Hooks [8]. In other research area, network resilience is defined as a function of quantity of routes between all node pairs by Ip and Wang [9]. On the other hand, resilience is defined as a tool to observe outcomes of disruption qualitatively. Zhang *et al.* [10] evaluate resilience as a function of change in system mobility, accessibility and reliability from pre-disruption levels for intermodal transportation systems. In this study, resilience is defined as capability of network to withstand and recover from disruption and disaster [11]. Therefore, transporting relief items to beneficiaries using unaffected way on the time is proposed. In this definition, unaffected way means that the routes for transportation are not disrupted. The resilience of a demand node is evaluated by means of its available distributed suppliers with reliable delivery paths [12]. Because of disruption, relief items might not reach to beneficiaries on the time via the most suitable transportation mode. Therefore, in the post disaster period, other transportation modes should be

considered. Otherwise, it might cause many problems that would eventually increase the number of deaths, decrease the life expectancy of injured people.

In this thesis, we studied the humanitarian logistics operations in Turkey, which is a country located on the Alpine-Himalayan seismic belt and has critical importance in humanitarian logistics due to frequent earthquakes and other natural disasters. In Table 1, the natural disasters, number of their occurrences, total deaths, total affected people and total damage cost in Turkey between 1900 and 2015 are presented [13].

Table 1 Natural Disasters in Turkey Between 1900 and 2015.

Disaster	# of Events	Killed	Total Affected	Damage (000US\$)
Earthquake (seismic activity)	77	89,236	6,924,005	24,685,400
Epidemic				
Bacterial Infectious Diseases	1	11	150	-
Parasitic Infectious Diseases	2	-	1,000,000	-
Viral Infectious Diseases	5	602	104,705	-
Extreme temperature				
Cold wave	3	69	-	-
Extreme winter conditions	2	17	8,150	-
Heat wave	2	14	300	1,000
Flood				
Unspecified	11	897	372,617	65,000
Flash flood	10	243	1,341,382	1,892,000
General flood	18	202	64,521	238,500
Mass movement dry				
Avalanche	1	261	1,069	-
Mass movement wet				
Avalanche	2	146	6	-
Landslide	10	293	13,481	26,000
Storm				
Unspecified	4	49	3	-
Local storm	5	51	13,636	2,200
Wildfire				
Forest fire	5	15	1,150	-

The earthquake occurred on 17th August 1999 in Marmara Region, which is the most industrialized region of Turkey, is a milestone for Turkey. Because of this earthquake, 17,479 people died, 43,953 people were injured and many of which lost their houses [14]. The government and researchers focused more on the earthquakes and their possible causes in this region. For example, many academicians and government bodies investigated the potential ways to prevent Istanbul, the most crowded city of the country from potential disasters (Parsons *et al.* [15], Özdamar *et al.*[16] , Görmez *et al.* [17], Salman and Gül [18], JICA [19]). From this viewpoint, in this study, scenarios for the mathematical models are developed using Turkish cities. The motivation of this study is to design a resilient transportation system for the earthquake-prone region of Turkey by using intermodal freight transportation (IFT).

In this study, IFT is considered to transport relief items provided by national and international suppliers and four transportation modes, which have different intermodal terminal and vehicles, are used. These modes are:

- Highway
- Railway
- Seaway
- Airway (plane, helicopter)

A relief item is transported in IFT without handling the item itself. This is the most critical difference between IFT and multi-modal transportation. Intermodality is defined as “a system of transport whereby two or more modes of transport are used to deliver the same loading unit or truck in an integrated manner, without loading or unloading, in a [door-to-door] transport chain” [20]. On the other hand, Multi-Modal is “transport of goods by at least two different modes of transport”. Intermodal transport is a particular type of multimodal transport [20]. To accomplish not handling of the items, intermodal transportation unit (ITU) and unit loading device (ULD) are used to transport relief items from suppliers to disaster areas in mathematical models. ITU is defined as a container; either a swap body, on a vessel, road or a rail vehicle [21]. On the other hand, “A Unit Load Device (ULD) is either an aircraft pallet and pallet net combination, or an aircraft container.” [22]. To utilize IFT, suppliers load relief items to ULDs then load ULDs to ITUs. Thereby ULDs are handled but relief items are not handled in IFT terminals as shown in Figure 1.

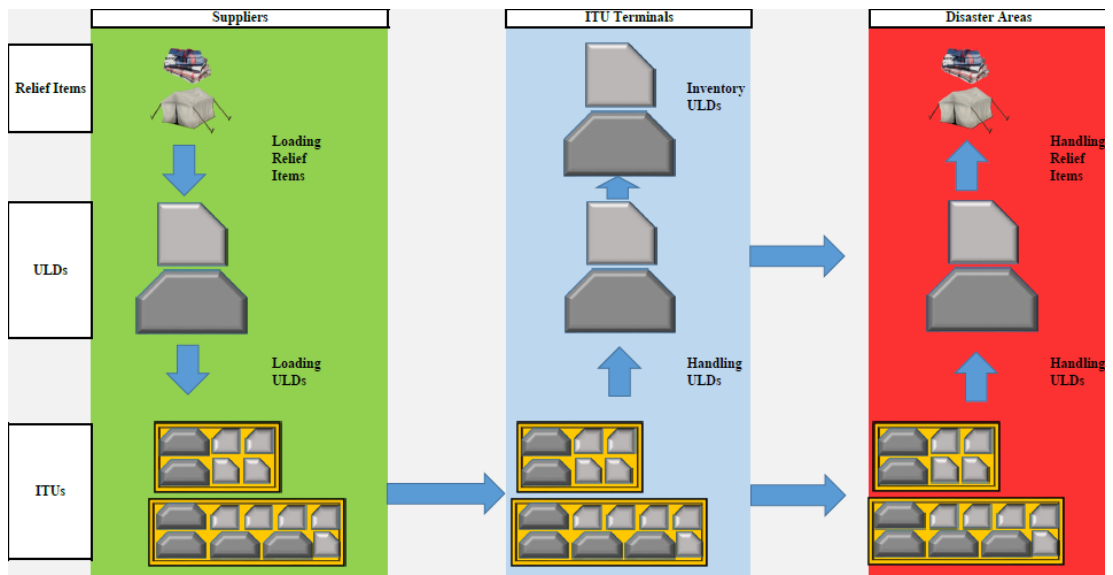

Figure 1 Transportation of relief items with ULD

The main purpose of this study is to find a feasible and efficient solution for resilient transportation of relief items supplied from national and international organizations to earthquake-prone region of Turkey. To represent a resilient system without handling of relief items, two mathematical models, which are based on the concept of a time-space network by using integer programming with considering route, vehicle availabilities and capacities of vehicles and ITU terminals based on time horizon, are developed. Objective functions of mathematical models minimize total transportation, loading, unloading and inventory holding cost of relief items in ULDs.

The study continues as follows: Chapter 2 presents a literature review on intermodal transportation, multi-modal transportation, ITU types and ULD types. The problem is defined under consideration in Chapter 3. In Chapter 4, the mathematical models developed for the resilient system of intermodal freight transportation are introduced. In Chapter 5, experimental study that consists of scenarios, data of run sets, solutions and their comparisons is given. Finally, in Chapter 6, the conclusion and several ideas for future research are discussed.

CHAPTER 2

LITERATURE REVIEW

Van Wassenhove classified disasters using two categories: (1) source (i.e., natural or man-made) and (2) occurrence duration (i.e., sudden-onset or slow-onset) [23]. In 2013 Duran *et al.* added one more dimension to this classification concerning the location of a disaster (Figure 2) [24].

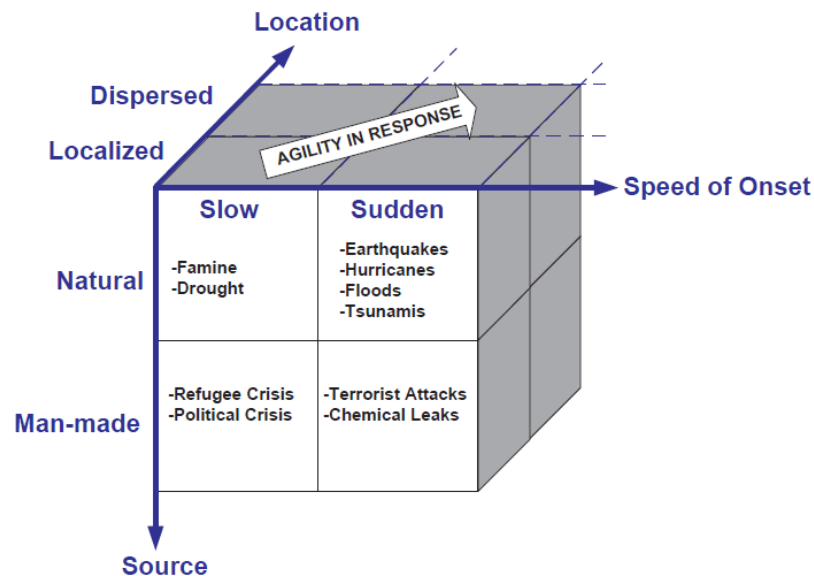

Figure 2 Classification of disasters [24].

Disaster management is defined as “the whole of the operations aiming to prevent / reduce injuries, fatalities, and damage worth and to facilitate recovery from the onset of a disaster” [24]. IFRC defined disaster management as “the organization and management of resources and responsibilities for dealing with all humanitarian aspects of emergencies, in particular preparedness, response and recovery in order to lessen the impact of disasters” as presented in Figure 3 [25].

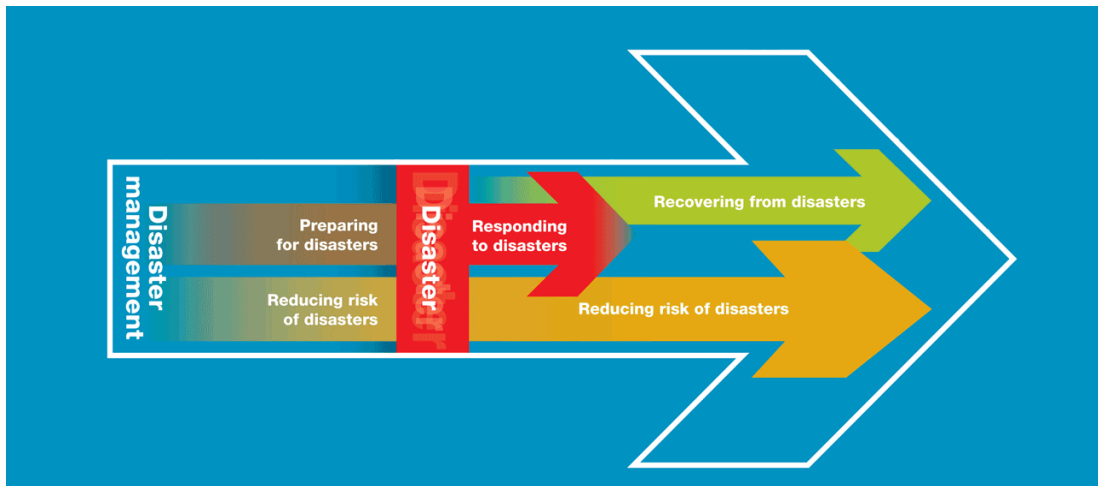

Figure 3 The schematic definition of a disaster by IFRC [44].

2.1 Humanitarian Logistics and Phases of a Disaster

Altay and Green refer to disaster management in terms of four phases, which are mitigation, preparedness, response and recovery; these phases are also referred in the literature as “life cycle of a disaster” (Figure 4) [26].

Mitigation is happens pre-disaster and it can be considered as the prevention phase. It consists some activities, which reduce the impacts of unavoidable disasters and to be resilient for the disasters yet to occur. Preparedness is also one of the pre-disaster activities and IFRC defined it as “Disaster preparedness refers to measures taken to prepare for and reduce the effects of disasters. That is, to predict and, where possible, prevent disasters, mitigate their impact on vulnerable populations, and respond to and effectively cope with their consequences” [27]. Response phase refers to apply plans prepared according to emergency procedures in the preparedness phase which are allocating resources, preservation of life, environment and structures of community when a disaster happens. The final post-disaster phase is the recovery phase, which refers to activities to continuously help beneficiaries after the first emergency period and reconstructing disrupted elements of their life and fighting back future disasters by increasing their capabilities [28].



Figure 4 Phases of disaster management. [29]

The four phases of the life cycle of disasters are studied as continuous process (Figure 4) [29]. As indicated in Duran *et al.*, relief operations of disaster management are listed in Table 3 [24]. According to Table 3, there is a precedence relationship between relief operations of preparedness and response phases. To transport relief items to the beneficiaries in the response phase, planning and purchasing operations have to be finished during the preparedness phase. Recovery phase is related to response phase for transporting relief items such as long term food supplies and housing.

Table 2 Operations in the phases of disaster management [24]

Pre-Disaster		Disaster	Post-Disaster
Mitigation	Preparedness	Response	Recovery
<ul style="list-style-type: none"> -Barrier Building -Lead Location Choices: <ul style="list-style-type: none"> -Tax incentives -Tax disincentives -Improving: <ul style="list-style-type: none"> -Building codes -Risk Analysis -Building resistance -Educating <ul style="list-style-type: none"> -Community 	<ul style="list-style-type: none"> -Planning <ul style="list-style-type: none"> -Locations of -Operations centers -Pre-positioned items -Emergency vehicles -Distribution means -Advance Purchasing: <ul style="list-style-type: none"> -Relief Items -Vehicles -Equipment -Educating <ul style="list-style-type: none"> -personnel 	<ul style="list-style-type: none"> -Assess relief need -Emergency Rescue -Activating <ul style="list-style-type: none"> -Operation centers -Rescue teams -Mobilizing Relief Items <ul style="list-style-type: none"> -First Phase <ul style="list-style-type: none"> -food, water -Second Phase <ul style="list-style-type: none"> -Housing -Planning for <ul style="list-style-type: none"> -the last mile 	<ul style="list-style-type: none"> -Debris removal -Infrastructure rebuild -Designing sustained <ul style="list-style-type: none"> -medical care -food supply -Assess performance -Feedback to <ul style="list-style-type: none"> -Planning -Response

Related literature [26, 30, 31, 32, 33 and references therein] is classified according to disaster management phases. Prevalence of the phases are shown in Table 3. For instance, mitigation is mentioned alone 32 times in 272 academic studies that was examined during the literature review. In another example, four phases are considered altogether in 17 studies whereas the preparedness and response phase are taken as a basis to the developed mathematical models.

Table 3 Number of study considers phases

Phases				Number of Study	%
Mitigation				32	11.8
Preparedness				26	9.6
Response				114	41.9
Recovery				10	3.7
Mitigation	Preparedness			2	0.7
Mitigation	Response			2	0.7
Preparedness	Response			45	16.5
Response	Recovery			9	3.3
Mitigation	Preparedness	Response		3	1.1
Mitigation	Response	Recovery		1	0.4
Preparedness	Response	Recovery		4	1.5
Mitigation	Preparedness	Response	Recovery	17	6.3
Not mentioned				7	2.6
TOTAL				272	100

Figure 5 presents number of studies and their corresponding percentages in 272 studies. The response phase is studied the most. In this thesis, the response phase is chosen as the main phase for the problem setting as well.

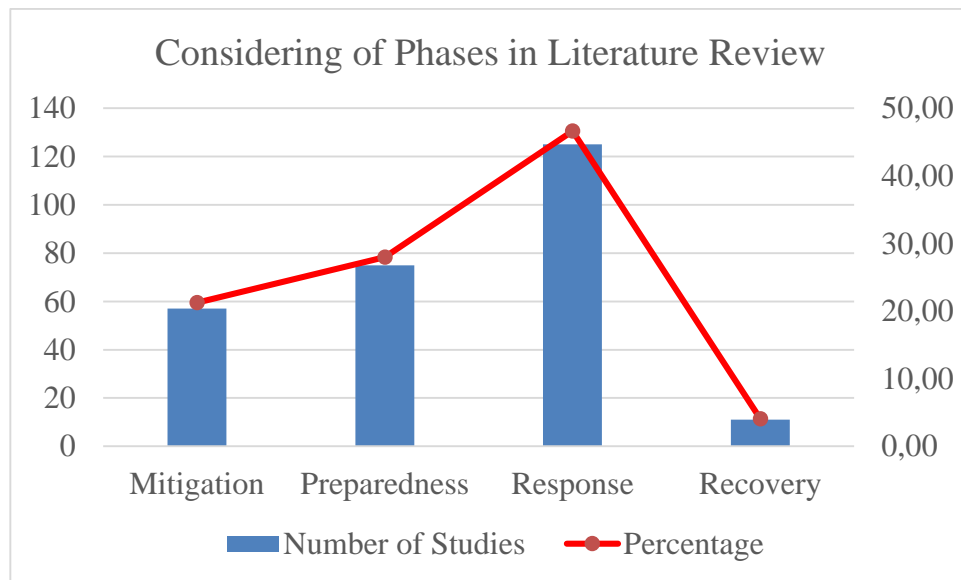

Figure 5 Considering of phases in literature review.

Humanitarian logistics is central in the operations of disaster management [24].

Thomas and Mizushima have defined humanitarian logistics as

“The process of planning, implementing and controlling the efficient, cost-effective flow and storage of goods and materials as well as related information, from the point of origin to the point of consumption for the purpose of meeting the end beneficiary’s requirements [34].”

Based on this definition, applications of supply chain management are also important for disaster management. Therefore, some researchers also used the term humanitarian supply chain management.

Humanitarian supply chain management (SCM) differs from commercial SCM in many issues. The comparison between two management systems is presented in Table 4 [35].

Table 4 Differences between Commercial SCM and Humanitarian SCM [48]

Topic	Commercial SCM	Humanitarian SCM
Main objective	Maximize profit	Save lives and help beneficiaries
Demand pattern	Fairly stable and can be predicted with forecasting techniques	Irregular with respect to quantity, time, and place. Demand is estimated within the first hours of response
Supply pattern	Mostly predictable	Cash is donated for procurement. Unsolicited donations, and in-kind donations need sorting, prioritizing to decrease bottlenecks
Flow type	Commercial products	Resources like evacuation vehicles, people, shelter, food, hygiene kits, etc.
Lead time	Mostly predetermined	Approximately zero lead time, demand is needed immediately
Delivery network structure	Established techniques to find the number and locations of warehouses, distribution centres	Ad-hoc distribution facilities or demand nodes, dynamic network structure
Inventory control	Safety stocks for certain service levels can be found easily when demand and supply pattern is given	Unpredictable demand pattern makes inventory control challenging. Pre-positioned inventories are usually insufficient
Technology and information systems	Highly developed technology is used with commercial software packages	Less technology is used, few software packages that can record and track logistics data. Data network is non-existent
Performance measurement method	Based on standard supply chain metrics	Time to respond the disaster, fill rate, percentage of demand supplied fully, meeting donor expectation
Equipments and vehicles	Ordinary trucks, vehicles, forklifts	Robust equipment are needed to be mounted and demounted easily
Human resources	Commercial SCM is now a respected career path (Thomas, 2003)	High employee-turnover, based on voluntary staff, harsh physical and psychological environment
Stakeholders	Shareholders, customers, suppliers	Donors, governments, military, NGOs, beneficiaries, United Nations etc.

In 2009, Natarajarathinam *et al.*, classified humanitarian logistics into five main characteristics: (1) source, (2) scale, (3) stage, (4) research method and (5) respondent. This classification can be seen as a framework in Figure 6 [31]. According to this framework, this thesis aims to develop an analytical and applicable non-profit supply chain system, which has internal and external sources, considering response and recovery phases in detail.

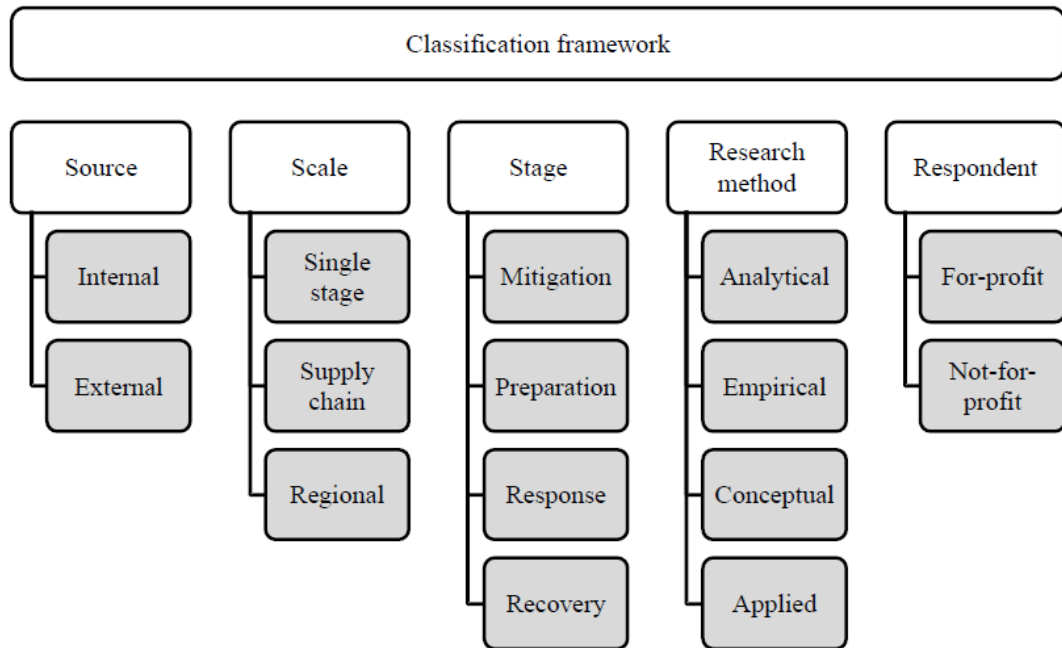

Figure 6 Classification framework of Humanitarian Logistics [49].

2.2 Models Developed in Humanitarian Logistics

Studies related to the disaster management are classified according to the types of mathematical models and presented in Table 5. For instance, in 272 studies, 41 times Evacuation models are studied. In some studies, more than one model type is considered. In this thesis, developed mathematical models focus on relief supplies distribution, inventory and resource allocation.

Table 5 Number and percentage of model types studied in disaster management.

Model	Count	Percentages
Evacuation	41	13.53
Facility location	29	9.57
Inventory	13	4.29
Relief supplies distribution	53	17.49
Resources allocation	35	11.55
Others	132	43.56
Total	303	100

Usage of different transportation modes are also analyzed based on the reviewed literature. There are many transportation types which are studied in literature such as multi-modal, single-modal, and intermodal etc.

According to model types, there are only 37 in 303 counts of model types in 272 studies that mentioned about transportation modes, which makes the transportation modes a poorly studied area in this concept, given the early researchers in the field emphasize that

“The basic underlying logistical problem for disaster relief management is to move a number of different commodities using a number of different modes of transportation, from a number of origins to one or more destinations over a transportation network in a timely manner effectively and efficiently” [36].

Table 6 Number of transportation modes considered

Model	Transportation mode is mentioned	Not mentioned	Total	Percentages
Evacuation	5	36	41	12.20
Facility location	1	28	29	3.45
Inventory	2	11	13	15.38
Relief supplies distribution	17	36	53	32.08
Resources allocation	3	32	35	8.57
Others	9	123	132	6.82
Total	37	266	303	78.49
Percentages	12.21	87.79	100.00	

Usage of transportation mode is presented in Table 6 according to the reviewed models. Percentage of different transportation mode mentioned in models of relief supplies distribution is approximately % 32. Thus, another motivation of this study is to transport relief items to beneficiaries by using different transportation modes providing more available paths for a resilient system.

Table 7 Number of models used transportation methods

Usage of Methods	Transportation Methods		
	Intermodal	Multi-Modal	Multi-Vehicle
Used	0	14	19
Not Used	272	258	253
Total	272	272	272

Three types of transportation methods are searched in 272 studies for this thesis and numbers of each type of transportation method studied are presented in Table 7. As of this thesis was written, only multi-modal and multi-vehicle methods (more than one vehicle in same type) were taken into account and intermodal transportation has never been used within the context described in this thesis. This is the most powerful motivation for this thesis.

In 1987, Knott developed a mathematical model, which was a single modal and single relief item to minimize total transportation cost [30]. The study pioneered the disaster relief transportation and inspired many researchers to further investigate the modal network flow problem.

As it can be seen in Table 5, most of the studied model types are evacuation and relief supplies distribution. Thereby, Özdamar and Ertem emphasized response phase models into these two main model types [37]. Also in Özdamar and Ertem, relief supplies distribution models and evacuation models are classified according to their model type, objective(s), constraints and solution methods. Their classification is presented in Table 8 which was enhanced with five number of articles in the last rows of Table 9.

Table 8 Models for relief delivery and casualty transport (Enhanced from [37]).

Citation	Model Type	Objective(s)	Constraints	Solution Methods
Haghani and Oh (1996)	DNF	OC	CV, D, MC, MD, SLD, TW	Lagrangean relaxation
Özdamar <i>et al.</i> (2004)	DNF	CUD	CV, D, LS, MC, MD, MM, SLD	Lagrangean relaxation, Modified Shortest Path
Yi and Özdamar (2007)/ Özdamar and Yi (2008) / Yi and Kumar (2007)	DNF	WUD (CUD+CUC)	CV, DP, LS, MC, MD, MF, MPS, MPQ, SLD	Exact / Tour construction / Ant colony algorithm
Zhan and Liu (2011)	DNF	ETT, EUD	CV, D, DU, LS, RU, SU	Two-stage stochastic program with recourse
Afshar and Haghani (2012)	DNF	WUD (CUD+CUC)	CV, D, LS, MC, MD, PL, SLD	Exact
Najafi <i>et al.</i> (2013)	DNF, Robust Optimization	(CUD+CUC)+NV	CU, CV, DP, DU, LS, MC, MD, MF, MM, SLD, SU	Exact
Özdamar (2011)	SNF	TT	CV, DP, LS, MD, MC, MF, PAY, RE, SLD	Exact
Özdamar and Demir (2012)	SNF	TD	CV, DP, LS, MC, MD, MF, SLD	Hierarchical Planning, Clustering
Zhang <i>et al.</i> (2012)	UNF	TT (primary and secondary disasters)	D, LS, MC, MD, UV	LP based heuristic
Barbarosoğlu and Arda (2004)	UNF	TC	D, DU, MC, MD, MM, RU, SU, UV	Two-stage stochastic program with recourse
Tzeng <i>et al.</i> (2007)	UNF	EQD, TC, TT	D, LS, MC, MD, SLD, UV, 2stage supply chain	Exact
Gu (2011)	UNF (fuzzy)	UD	LS, TTU, TW, UV	Exact
Balçık <i>et al.</i> (2008)	RE, dynamic	TC, minimax CUD(EQD)	CV, D, LS, MC, MD, SD, TW	Exact
Lin <i>et al.</i> (2011)	RE, dynamic	EQD, TT, UD	CV, D, MC, SD, SLD, TW, WTW	Decomposition, GA
Hsueh <i>et al.</i> (2008)	CVR	TT, LA	CV, DP, TTU, TW, dynamic scheduling	Route construction heuristic
Barbarosoğlu <i>et al.</i> (2002)	CVR	OC, RT	CV, DP, MC, PAY, RE, SD, SLD	Hierarchical Planning
de Angelis <i>et al.</i> (2007)	CVR	SD	CV, D, MD, PL, TW	Exact
Shen <i>et al.</i> (2009)	1 st stage: Stochastic 2 nd stage: LP	UD, AT	CV, D, DU, RTD, SD, SLD, TTU	Exact, Tabu Search
Vitoriano <i>et al.</i> (2009, 2011)	CVR: goal prog.	EQD, OC, RR, RS	BUD, CV, DP, MD, STE	Exact
Berkoune <i>et al.</i> (2012)	CVR	TT	CV, D, MC, MD, WTW	Set enumeration heuristic, GA
Nolz <i>et al.</i> (2011)	CVR, Covering TSP	AP, MCD, TT, UN	CV, PC, SD, STE	Memetic Algorithm
Sheu (2010)	-	SD	D, DU, UV	Fuzzy Clustering Heuristic
Hu (2011)	CVR	TC, TT	BUD, D, MM	Exact

Table 8 (cont) Models for relief delivery and casualty transport (Enhanced from [37]).

Citation	Model Type	Objective(s)	Constraints	Solution Methods
Zhu <i>et al.</i> (2008)	SNF	TC	D, MC, MD, MM	LP relaxation
Clark and Culkin (2012)	DNF-TS	NV, UD, TC	CV, D, DU, LS, MM, MC, MD, PAY, RU, TW, WTW	Exact
Adivar and Mert (2010)	UNF-TS (fuzzy)	TC, SD	CV, DP, DU, LS, MC, MD, MM, RU, TTU, WTW	Exact, Parametric Programming
Salmeron and Apte (2010)	SN	CUD, EUD	BUD, CV, D, LS, MC, MD, MF, PC, PAY	Two-stage stochastic program with recourse

Legend: Objectives: AP: number of alternative paths, AT: vehicle arrival time, CUC: cumulative unmet demand over time, CUD: cumulative unserved casualties, EQD: equity of satisfied demand, ETT: Expected Travel Time, EUD: expected unmet demand, FT: flow time, LA: late arrivals, MCD: maximal demand covering, NV: number of vehicles in transit, OC: operation cost, RR: road reliability, RS: road security, RT: response time, SD: satisfied demand, TC: transport cost, TD: travel distance, TT: travel time, UD: unmet demand, UN: unreachability of nodes, WUD: weighted unmet demand; **Constraints:** BUD: budget for vehicles, CU: casualty uncertainty, CV: capacitated vehicles, D: delivery only, DP: delivery and pickup, DU: demand uncertainty, LS: limited supplies, MC: multicommodity, MD: multi-depot, MF: medical facilities, MM: multi-mode transport, MPS: medical personnel sharing, MSQ: medical service rates, PAY: helicopter payload, PC: population covering, PL: parking limitation, RE: refuelling, RTD: response time deadline, RU: road uncertainty, SD: single depot, STE: sub-tour elimination, SU: supply uncertainty, TTU: travel time uncertainty, TW: delivery time windows, UV: uncapacitated vehicles, WTW: working time windows, SLD: split deliveries (pickups); **Model Types:** DNF: dynamic network flow, TS: Time-Space Network, UNF: uncapacitated network flow, SNF: static network flow, CVR: classical vehicle routing, RE: route enumeration

Haghani and Oh developed a cost based dynamic network flow with time-space network (DNF-TS) model [37] which is multi-commodity, multi-period, multi-modal and multi-depot, to minimize total transportation cost and inventory holding cost with excluding disaster phases. They use a Lagrangean Relaxation approach to solve mathematical models because of the complexity [36]. On the other hand, multi-modal, multi-commodity and multi period DNF model is developed to minimize unmet demand of relief items in consideration of dynamic vehicle availability, response phase and recovery phase by Özdamar *et al.* and they proposed two solution methodologies which are Lagrangean Relaxation and modified shortest path heuristic [16]. Afshar and Haghani defined the capacity constraints, which are storage, parking and vehicle flow distinctly in a DNF-TS model minimizing unmet demand [51].

Yi and Özdamar developed a multi-objective DNF Location-Routing (LR) model to minimize unmet demands and injured people that means service delay with considering availability of vehicles and transportation [37], [39]. Their solution consists of two stages and the first stage is utilized by pseudo-polynomial route algorithm for the vehicles. Also Yi and Kumar studied the same model in considering availability of vehicles and routes. In order to solve this model, they used a two-stage Ant Colony Optimization heuristic which proposes finding routes in the first stage and solving maximum flow problem for flows of relief items. [40].

In another group of models, which is classified as static network flow (SNF) models, is related to *integrated models for relief delivery and casualty transport* [37]. To minimize total transportation time, a multi-commodity, multi-period and multi depot network flow problem, a novel model is developed by Özdamar in 2011 [41]. In this study, Routing Management Procedure is used to solve and helicopter is used as the transportation mean. Based on this, Özdamar and Demir enhanced scale of this model by considering 1000 nodes in their scenarios and they found a solution near optimal [42].

Balçık *et al.* present a dynamic route enumeration (RE) [37] model which has an exact solution, to minimize transportation, lost sales, and backorder costs in considering vehicle and route availabilities. It is also multi-period, multi-depot, and multi-commodity which refers to food, water, tent, and blanket [43]. From a different viewpoint, Lin *et al.* developed a multi-objective model to minimize cumulative unmet demand, transportation time, and pairwise difference of demand fill rates at nodes. They used a weighted sum method to reduce multi-objective to a single objective model and solved the model by using genetic algorithm and decomposition [44].

de Angelis *et al.* proposed a relief delivery model which maximizes demand satisfactory by using classical vehicle routing (CVR) approach [37]. Their study is multi-depot and multi-period model with single transportation mean [45]. In similar topic, a multi-objective vehicle routing model is developed by Vitoriano *et al.* in 2009 and 2011 [46] [47]. The model has three objectives that are minimizing transportation cost, maximizing ransack probability, and maximizing minimum reliability in links. In their model, only one transportation mode (mean) is considered and route availability

is not considered. For a similar case, a single objective vehicle routing model is proposed by Berkoune *et al.* [48]. For solving this problem, three approaches are considered. First of all, mathematical model (Integer Programming) which gives optimum solution with small size data set, is constructed by branch and bound algorithm by using solver CPLEX. But in large size problem, it takes more time than others. Second one is heuristic, which generates a quick and feasible solution. And the last one is genetic algorithm, which involves other approaches.

Barbarosoğlu *et al.* developed a modified CVR model that minimizes the maximum tour duration among all helicopters. Their model has pickup and delivery constraints and its solution is founded by two stage hierarchical planning approach [49]. Another delivery/pickup dynamic CVR is developed by Hsueh *et al.*, and aimed to minimize total transportation time with considering vehicle and route availabilities [50].

Özdamar and Ertem consider also uncertainties of model while they classify the related literature [37]. In this category, Shen *et al.* present a vehicle routing model for relief delivery in two stages: (1) Stochastic Programming and (2) Linear Programming. Their model minimizes unmet demand and total visit time in a multi-depot setting. Accordingly, demand and transportation times are uncertain for the man-made disaster in their model [51]. On the other hand, relief delivery models related to resilience in the network flow are developed, in order to minimize unmet demand and transportation time while considering deterministic route availability by Zhan and Liu [52] and uncertain route availability by Nolz *et al.*[53].

Najafi *et al.* developed a DNF model with demand uncertainty. Their model has two objectives, which are minimizing unmet demand and number of vehicles [54]. Additionally, they developed a robust approach for the distribution plan. Thereby, they propose it to develop a solution methodology that refers to customized robust modelling approach.

Özdamar and Ertem also classify uncapacitated network flow problems (UNF) [37]. Barbarosoğlu and Arda developed a model which is cost based. Their solution is constructed based on a two stage stochastic program considering uncertainties of demand route and supply [55]. On the other hand, deterministic two-staged network flow model is presented to minimize cost and time, and maximize equity-satisfied

demands by Tzeng *et al.* [56]. In another study, a network flow model with uncapacitated vehicles is developed to maximize demand satisfaction while considering uncertainties of transportation and delivery time by Gu [57].

Özdamar and Ertem emphasized the impact of defining type of vehicle on solvability of models [37]. In their study, models are categorized according to representation styles of capacitated vehicles. Özdamar and Ertem introduced vehicle representation in DNF approach as

“In the Dynamic Network Flow (DNF) approach vehicles are represented as integer valued flows that are linked with commodity flows in a multi-period (dynamic) network flow (NF) model. Vehicle flow variables have link (*from-to* nodes) indices and a *time* index that indicate the time of vehicle traversal over a link.” [37].

Table 9: Classifications of proposed models and related studies.

Citation	Model Type	Objective(s)	Constraints	Solution Methods
Haghani and Oh (1996)	DNF	OC	CV, D, MC, MD, SLD, TW	Lagrangian relaxation
Özdamar <i>et al.</i> (2004)	DNF	CUD	CV, D, LS, MC, MD, MM, SLD	Lagrangian relaxation, Modified Shortest Path
Clark and Culkin (2012)	DNF-TS	NV, UD, TC	CV, D, DU, LS, MM, MC, MD, PAY, RU, TW, WTW	Exact
Proposed Models	DNF-TS	HC, OC, TC	CV, D, INT, LS, MC, MD, MM, PAY, PL, RU, TW	Exact

Legend: **Objectives:** AP: number of alternative paths, AT: vehicle arrival time, CUC: cumulative unmet demand over time, CUD: cumulative unserved casualties, EQD: equity of satisfied demand, ETT: Expected Travel Time, EUD: expected unmet demand, FT: flow time, HC: holding cost, LA: late arrivals, MCD: maximal demand covering, NV: number of vehicles in transit, OC: operation cost, RR: road reliability, RS: road security, RT: response time, SD: satisfied demand, TC: transport cost, TD: travel distance, TT: travel time, UD: unmet demand, UN: unreachability of nodes, WUD: weighted unmet demand; **Constraints:** BUD: budget for vehicles, CU: casualty uncertainty, CV: capacitated vehicles, D: delivery only, DP: delivery and pickup, DU: demand uncertainty, INT: Intermodality, LS: limited supplies, MC: multicommodity, MD: multi-depot, MF: medical facilities, MM: multi-mode transport, MPS: medical personnel sharing, MSQ: medical service rates, PAY: helicopter payload, PC: population covering, PL: parking limitation, RE: refuelling, RTD: response time deadline, RU: road uncertainty, SD: single depot, STE: sub-tour elimination, SU: supply uncertainty, TTU: travel time uncertainty, TW: delivery time windows, UV: uncapacitated vehicles, WTW: working time windows, SLD: split deliveries (pickups); **Model Types:** DNF: dynamic network flow, TS: Time-Space Network, UNF: uncapacitated network flow, SNF: static network flow, CVR: classical vehicle routing, RE: route enumeration

In Table 9, proposed models are classified according to model type, constraints, objective and solution methodology with related studies. In addition to studies of Haghani and Oh, Özdamar *et al.* and Clark and Culkin, intermodality, limited parking area such a container capacity of warehouses and minimizing holding cost are considered. In order to ensure intermodality, intermodal transportation units (ITU) and unit loading devices (ULD) are defined for humanitarian logistics. Also, capacity is defined for these transportation units. Because of vehicle availabilities, transportation capacities of suppliers and warehouses are changed at each time period. Therefore, proposed models have dynamic capacitated suppliers and warehouses.

According to classification of Özdamar and Ertem, a DNF-TS model is developed to minimize transportation operation and inventory holding costs in considering availability of capacitated vehicles, routes and depots, multiple transportation means and multi-period while vehicles are represented as integers. Also, different from mentioned model previously, a DNF-TS model is developed with vehicles are represented as binaries [37].

2.3 Intermodal Freight Transportation and Transportation Units

In previous studies, mathematical models were developed considering multi-modal and multi-vehicle transportation. Intermodal transportation is not specifically analysed and modelled for humanitarian logistics before. In this thesis, intermodal transportation is proposed for humanitarian logistics.

Intermodal transportation is a combination of more than one mode of transport performed in a single transport chain [58]. Operations of freightage are performed by types of transportation vehicles that use railway, waterway, highway and airway. Differences between single mode and intermodal transportation are challenges that are made by capacity management, equipment and scheduling of resources [59]. And also there are differences between intermodal and multimodal transportation. Multimodal makes selection of a single mode from available modes [60]. The main difference between intermodal and multimodal transportation is whether the items are reloaded and redistributed, while the items are transferred from one mode to another. If the container is transferred from one mode to another without the items being handled (i.e., reloaded/redistributed), it is defined as intermodal transportation. On the other hand, if the items themselves in the container are unloaded, redistributed and transferred to another mode, it is defined as multimodal transportation. To ensure the condition of intermodal freight transportation, disaster relief items are loaded in unit loading devices (ULD), which can be handled during delivery. Additionally, ULDs are also loaded into intermodal freight transportation units (ITU); therefore, relief items are transported to disaster areas without handling.

Nowadays, there are many different types of loading units in transportation. These units are different from each other in their transportation modes and classified into two

groups as containers and pallets. Containers could be loaded and unloaded faster compared to other units. Moreover, they are more resistant to weather conditions and more protective for the potential damage of loading operation. On the other hand, the pallets are more of a use when the loading has special size/dimension and complicated to load into a container. The size of the containers is standardized by International Organization for Standardization (ISO) and defined as 20ft and 40ft. The 20ft containers are accepted as loading unit in transportation and its dimensions are standardized as 20x8x8 feet.

As it was mentioned before, the type of the loading unit changes depending on both the vehicle and mode of the transport. The types of loading units are grouped as [61]:

1. Land transportation loading units
2. Marine transportation loading units
3. Aerial transportation loading units.

Land transportation loading units

Land transportation units are investigated in two groups as road transportation and railway transportation. Loading units differ in road transportation depending on the size and capacity of the vehicle. The containers can be classified in three groups as their usage:

1. Container
2. Swapbody
3. Semi-trailer

In road transportation, commonly used containers are 48x53 feet long and has 94-179m³, 0.2-0.3 gr/cm³ carriage capacity. Whereas in railway transportation, the loading units are closed carriages that are 50x60 feet long and have 70-100 tones carriage capacity.

Marine Transportation Units

Marine transportation has a major role in worldwide transportation and the loading units, which are different than other ones, are 45x8x9 feet long and have 86.1 m³ carriage capacity.

Aerial Transportation Units

Aerial transportation is a high-cost transportation type in terms of service and the speed of the transport. The capacity and the size of a loading unit in aerial transportation depend on the type of the vehicle. These loading units are standardized by The International Air Transport Association (IATA), defined as Unit Loading Device (ULD) and are classified by their shapes, company origins and capacities [62]. IATA has developed a coding system to identify the type, size and the shape of ULDs. The code has 10 characters in three group letters and numbers such as AKE-12345-BA. The first three letters (AKE) define the type, size, and the shape, respectively. The 4-5 digit numbers (12345) indicate the serial number and the last two letters (BA) stand for the owner of the ULD.

In this thesis, we aimed to use the intermodal shipment system, which is a system based on freight transport using different modes without handling. As the size, shape and capacity of loading units differ between transportation modes, there is a clear need to define a loading unit for intermodal shipment system which requires a loading unit that can be used in any transportation mode. Previous studies and the authorities defined a unit for intermodal shipment as ILU (intermodal loading unit) [63] or ITU (intermodal transportation unit) [64] and there are many studies by European Commission, Framework Program and other organizations in order to improve the mode changes in intermodal transportation. However, many of the studies could not satisfy the need for defining a common loading unit in intermodal shipment. For example, the TelliBox (intelligent megaswapboxes for advanced intermodal freight transport), which was mentioned in 7th (Research and Technological Development) RTD Framework Program as loading unit in intermodal shipment, is a 45x3x3 feet long container that was proposed to speed up the mode changes in an economic way. However, the container can only be used in land and marine transportation. In order to use the TelliBox in aerial transportation, there would be a need to design new cargo planes.

Previous studies and the world history showed that in case of a natural disaster, the transportation should be resilient and as fast as possible, such as aerial transportation. In our project, by reason of using intermodal shipment in case of a natural disaster, the speed and resilience are prime of importance. Therefore, ULDs were used as loading

units in this project, which can be used as intermodal transportation. For example, the modular containers that are used in defence industry can be used in every transportation mode. Another ULD example is AKE (see above), which is mainly used in aerial transportation and could be used in other modes.

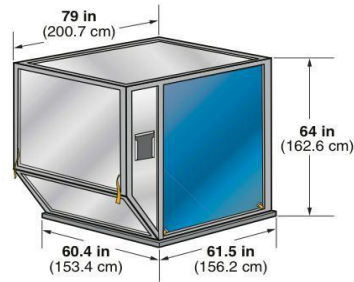

Figure 7 Unit loading device AKE

This study will explore the opportunities of intermodal freight transportation in resilient humanitarian aid delivery. The lifeline of beneficiaries is usually disrupted because of the impact of the disaster to the transportation infrastructure such as the disruptions occurred after the Tohoku Earthquake (March, 2011) in Japan. Hence, there is a need for practical models that will allow the use of alternative transportation modes. The objective of this study is to develop a mathematical model to support an undisrupted lifeline for the beneficiaries after a disaster. The lifeline will combine two related disciplines: humanitarian logistics and intermodal freight transportation. The limited number of scientific studies at the intersection of these two disciplines justifies attention from academicians.

In any disaster, one of the most important actions is to procure relief items for disaster areas. Unfortunately, conditions of environment may not be available for transportation relief items to disaster areas. Thus movements in disasters are vital and they are directly affect performance of humanitarian aid [65]. “*Utilizing appropriate transportation modes in the relief chain are critical to **effective relief operations** [65]*”. To provide a resilient lifeline, two mathematical models for intermodal freight transportation in humanitarian logistics are proposed and tested by using real data sets while considering availability of lifeline based on minimizing total transportation operation cost and inventory holding cost in this thesis.

CHAPTER 3

PROBLEM DEFINITION

In this chapter the problem settings are discussed. First, the problem is defined and then the structure of the transportation network is presented with a conceptual model. Finally, the assumptions for this study are presented.

3.1 Problem Definition and Transportation Network

Humanitarian logistics relief delivery problems are more complex than commercial supply chains because of uncertainties. In commercial supply chains, inputs such as demands, lead-time and flow type are mostly predictable with forecasting methods. On the other hand, in humanitarian supply chains, these inputs are not easily foreseen [35]. Additionally, in humanitarian logistics, the feasibility of ways of transportation of relief items is not predictable. For instance, a truck cannot cross a river whose bridge was collapsed. Moreover, in reality, the items and transportation modes usually are not singular and network flows of relief items may not be resilient. Another critical point that must be considered is the changing availability of modes and transportation elements according to time. Thus, in order to overcome the potential problems, dynamic vehicle availabilities, delivery path availabilities, vehicle capacities, depot capacities, lead time of vehicles, number of relief items, and different transportation means are considered. After the disaster occurs, capacities and availabilities will change as time progresses so that a dynamic model must be constructed. In a previous study, Yi and Özdamar developed a network flow model of an integrated capacitated location-routing problem (LRP) [39]. The researchers took the time into account with

modeling a framework that is considered as a flexible dynamic (multi-period) coordination instrument that can adjust to frequent information updates vehicle re-routing and re-allocation of service capacities for continuity of commodity logistics. In another study, a multi-commodity, multi-modal network flow model, whose formulation was constructed on the concept of the time-space network and two heuristic algorithms, were introduced for disaster relief operations, is determined [36]. We propose an intermodal, multi-commodity and multi-depot dynamic transshipment network flow model for delivery of disaster relief items in this thesis. Network for the transshipment model is illustrated for the 1 to S suppliers, 1 to WH warehouses (intermodal freight transportation (IFT) terminal) and 1 to DA disaster areas in Figure 8. Each arc from one node to another contains five modes, which are highway, railway, seaway, airway with 2 different air vehicle (air freighter and helicopter).

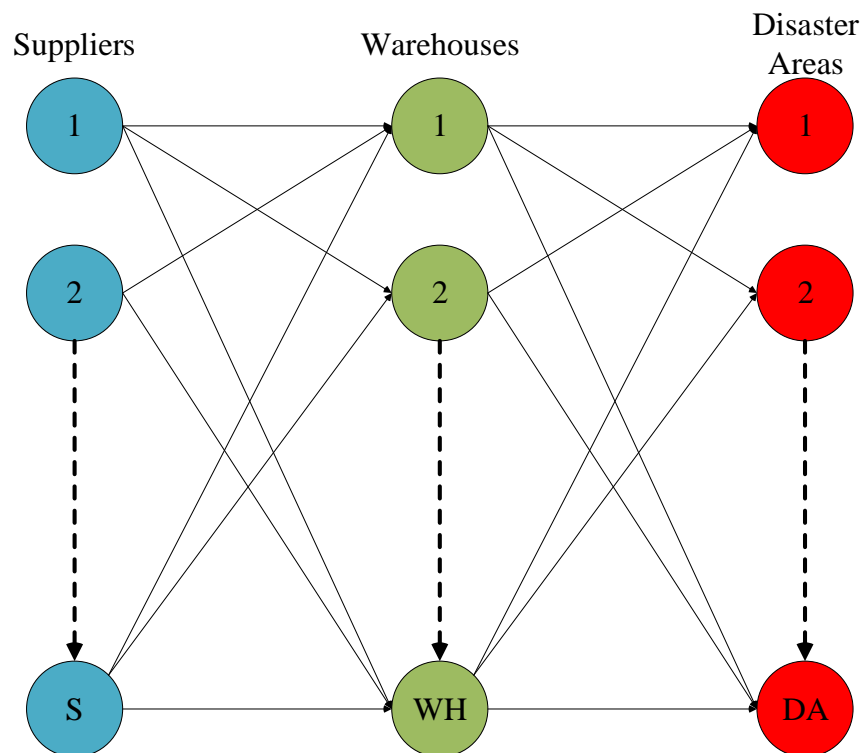

Figure 8 A transshipment network for transportation of disaster relief items

In this study, transshipment nodes refer to IFT terminals, which enables the change of transportation modes and holding inventory of unit loading devices (ULD) for a short term. Flow of relief items occurs from suppliers-to-warehouse and warehouse-to-disaster areas. If all transportation means are available for all paths, total number of paths in the network is $WH \times (S+DA) \times 5$. A graphical representation for the network

of dynamic transshipment model is presented in Figure 9. As seen in Figure 9, delivery of relief items is performed by multiple modes of transportation.

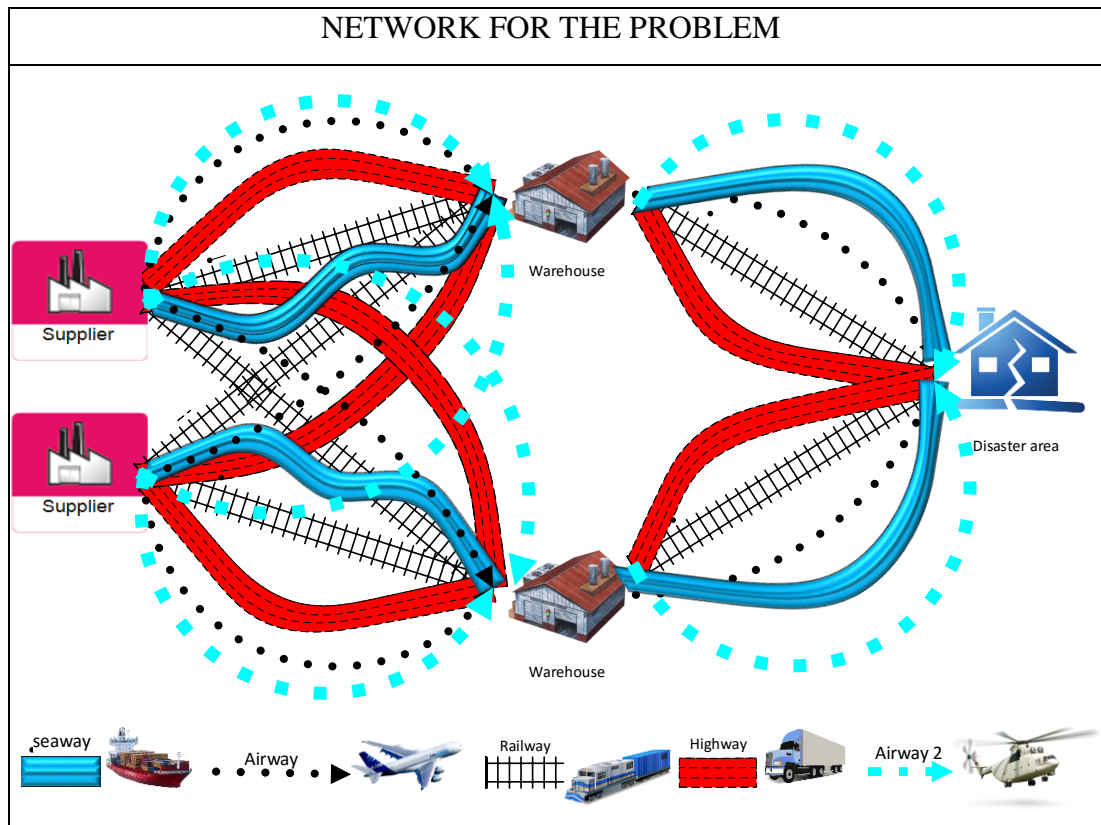

Figure 9 A graphical representation of the network

Transportation modes are classified according to vehicle types and chains (e.g., first truck then train). According to these classifications, the model assigns a mode combination, which has at least two vehicles to deliver relief items. Additionally, multi-depot approach is used to create alternative paths for a resilient lifeline and to provide more combinations for mode changing. From suppliers to disaster areas, many route combinations are determined to assign suitable transportation mode combination. Route availabilities are identified and the transportation vehicles that are suitable for these routes are determined. In Figure 10, routes between two nodes are shown.

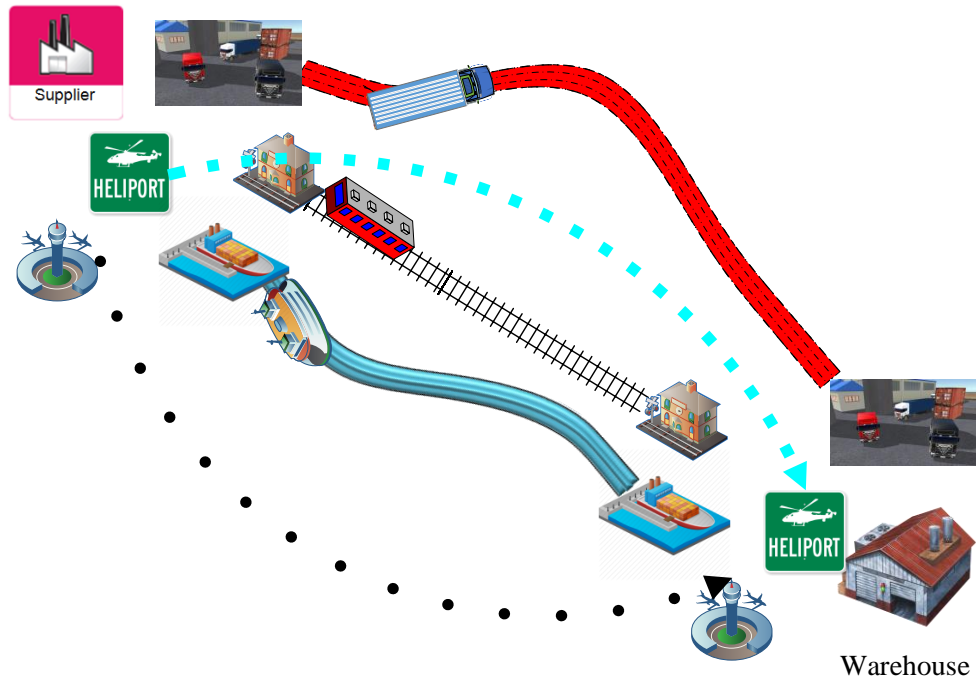

Figure 10 Transportation routes and modes

In this study, one of the resilience factors of lifeline is the routes' infrastructure. After the disaster occurs, routes may not have the same load capacity as before. Because of disruption, capacity of route may be reduced or the route may be unavailable completely. As presented in Figure 11, in case of a highway and railway disruption, the relief items should be delivered by another transportation mode that is available. Additionally, to assign modes to each path, nodes' availabilities have to be considered. Although the routes are available to deliver relief items, nodes may not be suitable or available for loading and unloading operations. For instance, in air transportation, even if the route is not disrupted, airport may be too congested for loading and unloading operations or one of the nodes might not accommodate an airport (Figure 11). Thereby, consideration of the availabilities of routes and nodes diversify our study from others.

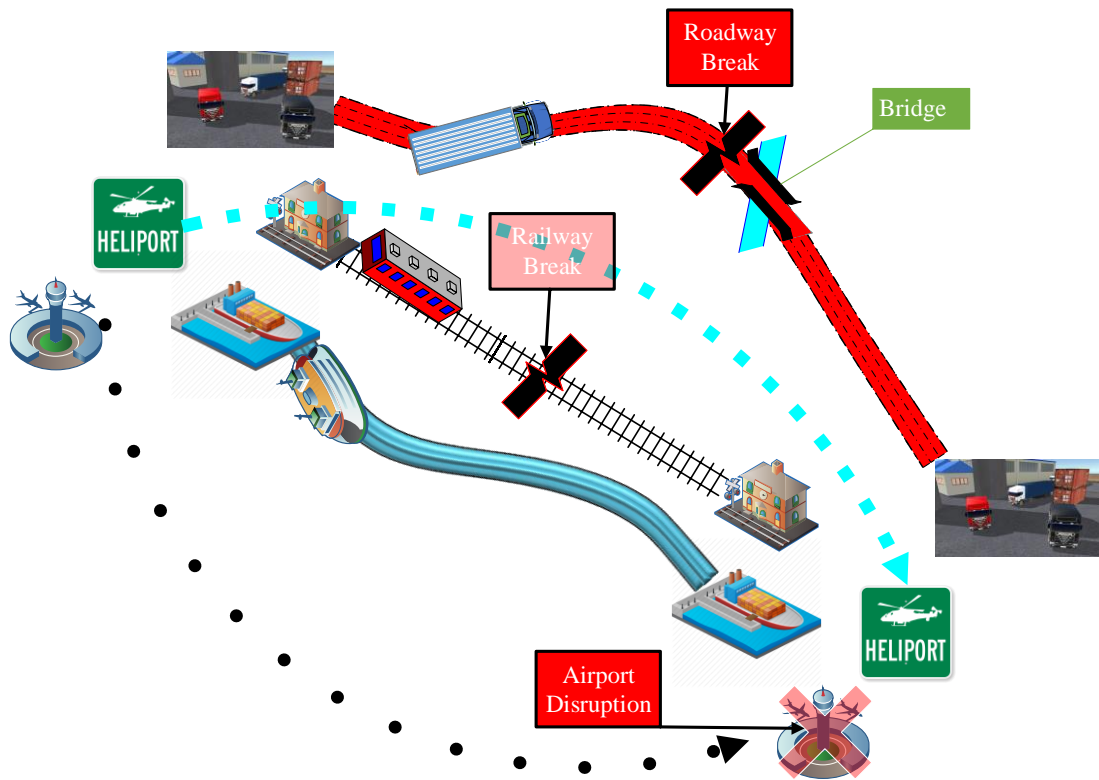

Figure 11 An illustration of disrupted routes.

Because of the disrupted highway, trucks cannot be used from supplier to warehouse so that other transportation modes should be considered. To supply the relief items on time, there should be alternative routes such as seaway and airway. This example shows us the importance of intermodal freight transportation for a resilient lifeline.

Another distinction of this study from other studies in terms of supplying relief items is that this study proposes IFT as a main part of humanitarian logistics. In previous studies, multi-modal or multi-vehicle model transportations are proposed for the delivery of disaster relief items while relief items are loaded and unloaded during transportation operations. On the contrary, the items are not handled in IFT, which is the main difference between multi-modal and intermodal. However, if an intermodal transportation unit (ITU) such as the commercial 40ft container is used to transport relief items airways cannot be used in delivery of relief items. Therefore, in this study, the ULD, which can be loaded in both ITUs and air freighters, is proposed in supplying relief items. In this case, the relief items are only loaded in suppliers and unloaded in

disaster areas. On the other hand, ULDs can be loaded and unloaded in only warehouses.

In this study, the capacities of ULD, ITU and vehicles are determined individually. Unit of capacity for ULD is the relief item. ITU capacity is in units of ULD. Capacity of vehicles is in units of ITU. Moreover, the term multi-commodity not only refers to different types of relief items, but also refers to different ULD and ITU types.

There are several steps for a loading operation in the conceptual model depicted in Figure 12. The first step belongs to relief items that are loaded in ULDs according to ULDs capacities at suppliers. After loading of relief items, they can be unloaded only at the disaster areas. Next step of loading operations is to load ULDs in ITUs and air freighters, according to their capacities at suppliers and ULDs can also be unloaded during the transportation operations. Lastly ITUs are loaded onto vehicles for the delivery of the items. The vehicle and route availabilities are considered while these operations are performed.

In this study, suppliers have unlimited relief supplies but limited number of vehicles to transport relief items. Similarly, warehouses also have limited number of vehicles but additionally inventory and transshipment capacities. Moreover, vehicle availabilities in supplier and warehouse nodes can alter in time. The number of vehicles at suppliers and warehouses reduce with each delivery. Also, the route availabilities can change with regard to time and that might affect transportation capacity of the network. Together with the previously described enhancements, these parameters evolve our model to a dynamic capacitated transshipment network flow model.

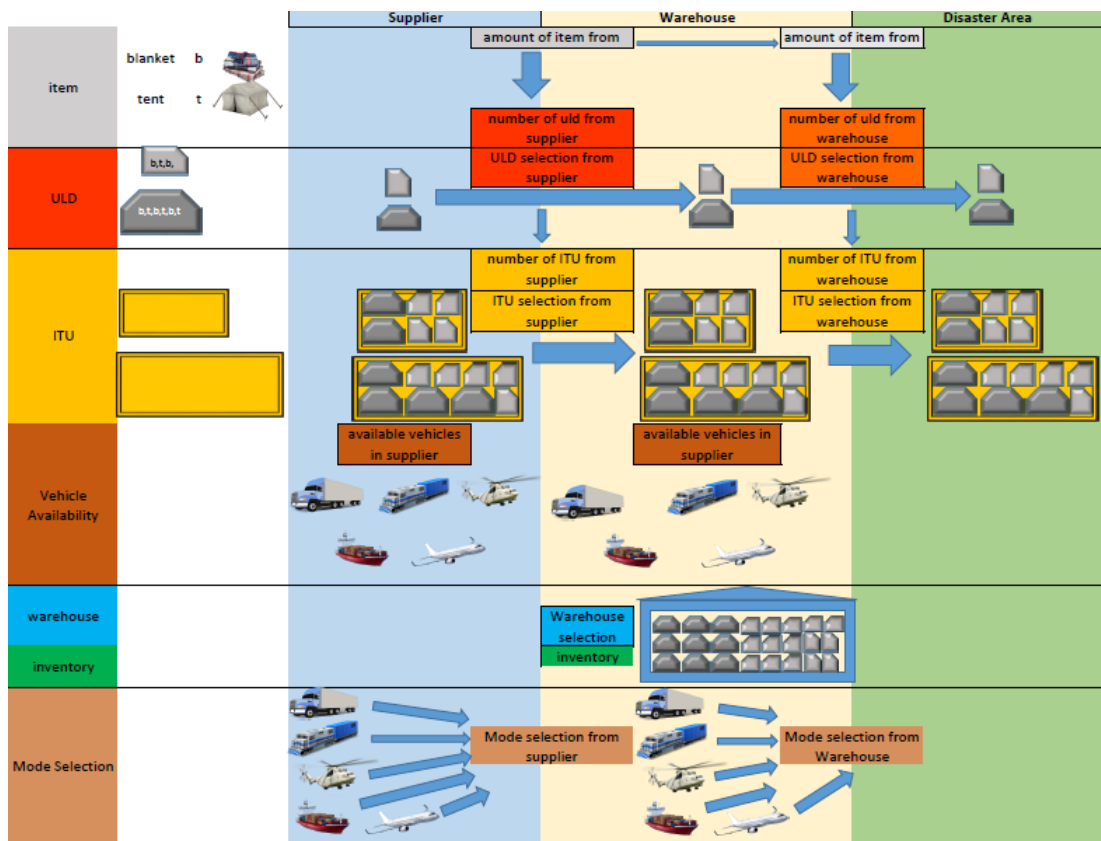

Figure 12 Conceptual model of the problem.

In IFT, more than one type of transportation mode is used, and the modes are changed in IFT terminals. In this study, IFT terminals refer to warehouses, which can keep an inventory as presented in Figure 12. Additionally, mode changings are performed at IFT terminals considering vehicle availabilities. The vehicles, which are defined as an inventory in this study, observe their availabilities at suppliers and warehouses (Figure 13). At the beginning of time horizon, suppliers and warehouses have limited number of vehicles for each available transportation mode. Additionally, for each period number of available vehicles must be equal to result while subtracting departure vehicle number from sum of available vehicles at previous period and arrival vehicle number at suppliers and warehouses in this model.

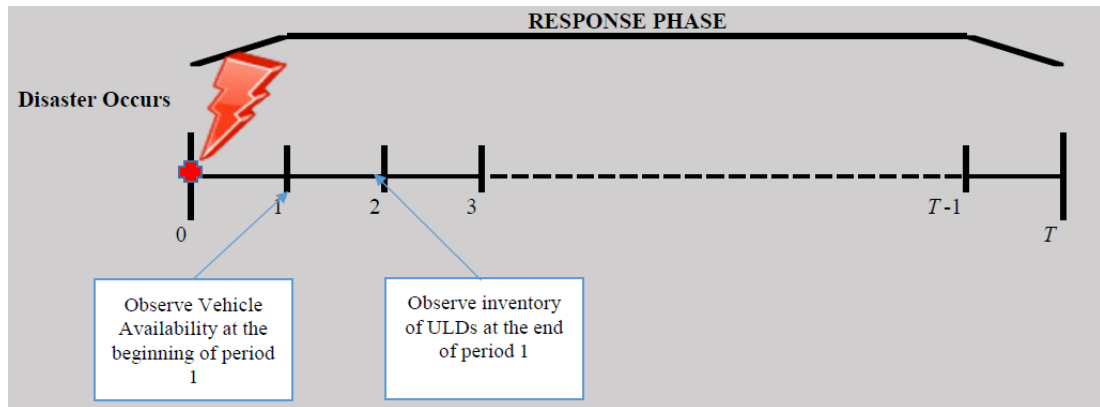

Figure 13 Time horizon of problem.

In IFT terminals, only inventory of ULDs is left over at the end of period (Figure 13). Additionally, ULDs are hold only at IFT terminals (Figure 12). Inventory holding areas are separated from loading and unloading areas of warehouses in this study. Therefore, warehouses have capacities for both ULDs and ITUs.

According to the principles mentioned above, the problem is to develop a dynamic capacitated transshipment network flow model for Intermodal Freight Transportation in Humanitarian Logistics with following constraints: (i) capacitated multi-depots vehicles and routes to minimize total transportation operation cost and total inventory holding cost, (ii) in a reasonable time window.

3.2 Assumptions

In disaster management, there are four phases: (1) mitigation, (2) preparedness, (3) response and (4) recovery. First two phases are related with before disaster, others are related with after disaster [24]. Because of uncertainties of demand, lead-time and other parameters, the model needs to meet these criteria so that they can be available after disaster occurred in this study. Thus, one of assumptions is that time period starts at the beginning of the response phase.

In this study, to develop a mathematical model for the problem, following assumptions are made.

1. There is no item, ULD, ITU and/or vehicle flow between warehouses.
2. There is no item, ULD, ITU and/or vehicle flow between suppliers.

3. There is no item, ULD, ITU and/or vehicle flow between disaster areas.
4. Item, ULD and/or ITU flow from warehouses to suppliers is not allowed.
5. Item, ULD and/or ITU flow from disaster areas to suppliers and warehouses is not allowed.
6. Item, ULD and/or ITU flow from suppliers to disaster areas is not allowed.
7. The vehicles in the suppliers have to return to the supplier where they depart after the delivery of the relief items to the warehouses.
8. The vehicles in the warehouses have to return to warehouse where they depart after delivery of the relief items to the disaster areas.
9. There are no warehouses at the disaster areas.
10. The warehouses can only hold ULDs for the next periods.
11. At beginning of the response phase, there are enough vehicles in the suppliers and warehouses.
12. All the warehouses are also a hub for changing transportation modes.
13. Only disaster areas have demand, which is in unit of number of the relief item.
14. Backorders and lost sales are not allowed.
15. Last mile distribution is not considered.

In the light of information above, the mathematical models are proposed in the next chapter.

CHAPTER 4

MATHEMATICAL MODEL

The problem defined in the previous chapter is formulated as two integer programming models (IPM) to minimize the total transportation and inventory holding cost in delivery of the disaster relief items to affected areas. In the first model, vehicles are represented as integer variables and defined as fleets that consist of transportation modes, whereas in the second model, they are represented as binary variables. Both models consist of five transportation modes.

4.1 Integer Programming Model (IPM-I) with Vehicles Represented as Integer Variables

In this model, vehicles are represented as integer variables. This model consists of fewer decision variables than the next one. Accordingly, fewer decision variables mean shorter computation times in runs. Vehicle availabilities are tracked as number of available vehicles at nodes, which are different from the second model. In the second model, capacity of vehicle is considered for each vehicle individually. On the other hand, capacity of vehicle is considered as the capacity of vehicle fleet that has available vehicles for the same transportation mode in the first model. Additionally, sets for vehicles and modes are different in the second model. Therefore, the first model consists of fewer sets and indices.

The index sets, parameters and decision variables of the IP model are presented below:

Sets

- IT Set of relief items which is in $1, \dots, H$
- S Set of supplier nodes which is in $1, \dots, I$
- WH Set of warehouse nodes which is in $1, \dots, J$
- TM Set of transportation modes which is in $1, \dots, K$
- DA Set of disaster areas which is in $1, \dots, M$
- TIM Set of time periods which is in $1, \dots, T$
- ITU Set of intermodal transportation unit type which is in $1, \dots, C$
- ULD Set of unit loading device type which is in $1, \dots, R$

Parameters

- DE_{hmt} = Demand of item h in disaster area m at time t
- ING_{hr} = Number of item h in unit loading device r
- $CWITU_j$ = Intermodal transportation unit capacity of warehouse j
- $CWULD_j$ = Unit loading device capacity of warehouse j
- $CITU_{rck}$ = Loading availability of unit loading device r into intermodal transportation unit c in transportation mode k
- CA_{ck} = Intermodal transportation unit c capacity of vehicle k
- SVB_{ki} = Number of available vehicles in transportation mode k of supplier i at the beginning of period $t=1$
- WVB_{kj} = Number of available vehicles in transportation mode k of warehouse j at the beginning of period $t=1$

$VULD_r =$ Volume of unit loading device r

$VITU_c =$ Volume of intermodal transportation unit c

$WEULD_r =$ Weight of unit loading device r

$WEITU_c =$ Weight of intermodal transportation unit c

$LEULD_r =$ Length of unit loading device r

$LEITU_c =$ Length of intermodal transportation unit c

$C_{rijk} =$ Cost of transporting one kilogram of unit loading device r from supplier i to warehouse j by using transportation mode k

$CO_{rjmk} =$ Cost of transporting one kilogram of unit loading device r from warehouse j to disaster area m by using transportation mode k

$CC_{cijk} =$ Cost of transporting an intermodal transportation unit c from supplier i to warehouse j by using transportation mode k

$CCO_{cjm k} =$ Cost of transporting an intermodal transportation unit c from warehouse j to disaster area m by using transportation mode k

$HO_{rjt} =$ Inventory holding cost of unit loading device r in warehouse j at time t

$InZero_{rj} =$ Inventory of unit loading device r in warehouse j at beginning $t = 1$

$A_{ijkt} =$ Availability of route from supplier i to warehouse j for transportation mode k at time t

$AV_{jmkt} =$ Availability of route from warehouse j to disaster area m for transportation mode k at time t

$LT_{ijk} =$ Needed time to transport items from supplier i to warehouse j by transportation mode k

$L_{jmk} =$ Needed time to transport items from warehouse j to disaster areas m by transportation mode k

$MCC_{jkk'}$ = Cost of cross dock operation between transportation modes k and k' in warehouse j

$$MCW_{kk'} = \begin{cases} 1 & \text{if arriving mode } k \text{ is same with departure mode } k' \text{ at warehouse} \\ 0 & \text{otherwise} \end{cases}$$

Q = Big number

TQ = Fixed cost of mode, intermodal transportation unit and warehouse selection

Decision Variables

$$MO_{ijkt} = \begin{cases} 1 & \text{if transportation mode } k \text{ is used to transport items from supplier } i \\ & \text{to warehouse } j \text{ at start of time } t \\ 0 & \text{otherwise} \end{cases}$$

$$N_{jmkt} = \begin{cases} 1 & \text{if transportation mode } k \text{ is used to transport items from warehouse } j \\ & \text{to disaster area } m \text{ at start of time } t \\ 0 & \text{otherwise} \end{cases}$$

$$W_{jt} = \begin{cases} 1 & \text{if warehouse } j \text{ is used in time } t \\ 0 & \text{otherwise} \end{cases}$$

V_{kit} = Number of available vehicle in mode k in supplier i at start of time t

VE_{kjt} = Number of available vehicle in mode k in warehouse j at start of time t

VU_{ijkt} = Number of vehicle in mode k used from supplier i to warehouse j at start of time t

VEU_{kjt} = Number of available vehicle in mode k used from warehouse j to disaster area m at start of time t

X_{hijkt} = Amount of item h transported by transportation mode k from supplier i to warehouse j at start of time t

Y_{hjmt} = Amount of item h transported by transportation mode k from warehouse j to disaster area m at start of time t

$SULD_{rcijkt}$ = Number of unit loading device r in intermodal transportation unit c transported by transportation mode k from supplier i to warehouse j at start of time t

$WULD_{rcjmkt}$ = Number of unit loading device r in intermodal transportation unit c transported by transportation mode k from warehouse j to disaster area m at start of time t

$SITU_{cijkt}$ = Number of intermodal transportation unit c transported by transportation mode k from supplier i to warehouse j at start of time t

$WITU_{cjmkt}$ = Number of intermodal transportation unit c transported by transportation mode k from warehouse j to disaster area m at start of time t

$$ITUS_{cijkt} = \begin{cases} 1 & \text{if intermodal transportation unit } c \text{ is transported from supplier } i \\ & \text{to warehouse } j \text{ by transportation mode } k \text{ at start of time } t \\ 0 & \text{otherwise} \end{cases}$$

$$ITUW_{cjmkt} = \begin{cases} 1 & \text{if intermodal transportation unit } c \text{ is transported from warehouse } j \\ & \text{to disaster area } m \text{ by transportation mode } k \text{ at start of time } t \\ 0 & \text{otherwise} \end{cases}$$

$$MC_{jkk't} = \begin{cases} 1 & \text{if there is a cross dock operation between transportation mode } k \text{ of} \\ & \text{supplier } i \text{ and transportation mode } k' \text{ of warehouse } j \text{ at start of time } t \\ 0 & \text{otherwise} \end{cases}$$

IN_{rjt} = Number of inventory of unit loading device r in warehouse j at the end of time t

IPM-I

The mathematical formulation of the IPM-I is as follows:

Objective function: To minimize total transportation operation cost and total holding cost.

$$\begin{aligned}
\text{Minimize } & \sum_{k=K-1}^K \sum_{j \in WH} \sum_{i \in S} \sum_{r \in ULD} \sum_{c \in ITU} \sum_{t \in TIM} C_{rijk} SULD_{rcijkt} WEULD_r + \\
& \sum_{k=K-1}^K \sum_{m \in DA} \sum_{j \in WH} \sum_{r \in ULD} \sum_{c \in ITU} \sum_{t \in TIM} CO_{rjmk} WULD_{rcjmkt} WEULD_r + \\
& \sum_{t \in TIM} \sum_{j \in WH} \sum_{r \in ULD} IN_{rjt} HO_{rjt} + \sum_{j \in WH} \sum_{k \in TM} \sum_{k' \in TM} \sum_{t \in TIM} MC_{jkk'} MCC_{jkk'} + \\
& \sum_{i \in S} \sum_{j \in WH} \sum_{k \in TM} \sum_{t \in TIM} VU_{ijkt} TQ + \sum_{j \in WH} \sum_{m \in DA} \sum_{k \in TM} \sum_{t \in TIM} VEU_{jmkt} TQ + \\
& \sum_{k \in TM} \sum_{m \in DA} \sum_{j \in WH} \sum_{c \in ITU} \sum_{t \in TIM} CCO_{cjmkt} WITU_{cjmkt} + \sum_{k=1}^{K-2} \sum_{i \in S} \sum_{j \in WH} \sum_{c \in ITU} \sum_{t \in TIM} CC_{cijkt} SITU_{cijkt} + \\
& \sum_{k=1}^{K-2} \sum_{m \in DA} \sum_{j \in WH} \sum_{c \in ITU} \sum_{t \in TIM} ITUW_{cjmkt} TQ + \sum_{k \in TM} \sum_{i \in S} \sum_{j \in WH} \sum_{c \in ITU} \sum_{t \in TIM} ITUS_{cijkt} TQ + \\
& \sum_{j \in WH} \sum_{t \in TIM} W_{jt} TQ
\end{aligned} \tag{1}$$

Subject to

- 1) Item demand of disaster area constraints

$$\sum_{k=1}^K \sum_{j=1}^J Y_{hjmkt} \geq DE_{hmt} \quad \forall h \in IT, \forall m \in DA, \forall t \in TIM \tag{2}$$

- 2) ULD demand

- i) From supplier to warehouse constraints

$$\begin{aligned}
X_{hijkt} &= \sum_{c \in ITU} \sum_{r \in ULD} ING_{hr} SULD_{rcijkt} \\
&\quad \forall h \in IT, \forall i \in S, \forall j \in WH, \forall k \in TM, \forall t \in TIM \tag{3}
\end{aligned}$$

ii) From warehouse to disaster area constraints

$$Y_{hjmkt} = \sum_{c \in ITU} \sum_{r \in ULD}^R ING_{hr} WULD_{rcjmnt}$$

$$\forall h \in IT, \forall j \in WH, \forall m \in DA, \forall k \in TM, \forall t \in TIM \quad (4)$$

3) ITU capacity constraints of vehicles

i) From supplier to warehouse

$$SITU_{cijkt} \leq CA_{ck} VU_{ijkt} \quad \forall c \in ITU, \forall i \in S, \forall j \in WH, \forall k \in TM, \forall t \in TIM \quad (5)$$

ii) From warehouse to disaster area

$$WITU_{cmjkt} \leq CA_{ck} VEU_{jmkt}$$

$$\forall c \in ITU, \forall m \in DA, \forall j \in WH, \forall k \in WVH, \forall t \in TIM \quad (6)$$

4) ULD capacity constraints of vehicles

i) From supplier to warehouse

$$\sum_{r \in ULD}^R LEULD_r SULD_{rcijkt} \leq LEITU_c SITU_{cijkt}$$

$$\forall c \in ITU, \forall i \in S, \forall j \in WH, \forall k \in TM, \forall t \in TIM \quad (7)$$

$$SITU_{cijkt} \leq ITUS_{cijkt} Q \quad \forall c \in ITU, \forall i \in S, \forall j \in WH, \forall k \in TM, \forall t \in TIM \quad (8)$$

$$ITUS_{cijkt} \leq SITU_{cijkt} \quad \forall c \in ITU, \forall i \in S, \forall j \in WH, \forall k \in TM, \forall t \in TIM \quad (9)$$

$$\sum_{j \in WH}^J \sum_{i \in S}^I \sum_{c \in ITU}^C ITUS_{cijkt} \leq 1 \quad \forall k \in TM, \forall t \in TIM \quad (10)$$

$$\sum_{c \in ITU}^C ITUS_{cijkt} \leq MO_{ijkt} \quad \forall i \in S, \forall j \in WH, \forall k \in TM, \forall t \in TIM \quad (11)$$

ii) From warehouse to disaster area

$$\sum_{r \in ULD}^R LEULD_r WULD_{rcjmnt} \leq LEITU_c WITU_{cmjnt}$$

$$\forall c \in ITU, \forall m \in DA, \forall j \in WH, \forall k \in TM, \forall t \in TIM \quad (12)$$

$$WITU_{cjmk} \leq ITUW_{cjmk} Q$$

$$\forall c \in ITU, \forall m \in DA, \forall j \in WH, \forall k \in TM, \forall t \in TIM \quad (13)$$

$$ITUW_{cjmk} \leq WITU_{cjmk}$$

$$\forall c \in ITU, \forall m \in DA, \forall j \in WH, \forall k \in TM, \forall t \in TIM \quad (14)$$

$$\sum_{j \in WH} \sum_{m \in DA} \sum_{c \in ITU} ITUW_{cjmk} \leq 1 \quad \forall k \in TM, \forall t \in TIM \quad (15)$$

$$\sum_{c \in ITU} ITUW_{cjmk} \leq N_{jmkt} \quad \forall m \in DA, \forall j \in WH, \forall k \in TM, \forall t \in TIM \quad (16)$$

5) Capacity constraints of warehouses

i) ULD capacity of warehouse

$$\sum_{k \in TM} \sum_{i \in S} \sum_{c \in ITU} \sum_{r \in ULD} SULD_{rcijk(t-LT_{ijk})} + \sum_{r \in ULD} IN_{rjt-1} \leq CWULD_j W_{jt} \quad \forall j \in WH, \forall t \in TIM \quad (17)$$

ii) ITU capacity of warehouse

$$\sum_{k \in TM} \sum_{i \in S} \sum_{c \in ITU} SITU_{cijkt(t-LT_{ijk})} \leq CWITU_j W_{jt} \quad \forall j \in WH, \forall t \in TIM \quad (18)$$

6) Availability of routes constraints

$$MO_{ijkt} \leq A_{ijkt} \quad \forall i \in S, \forall j \in WH, \forall k \in TM, \forall t \in TIM \quad (19)$$

$$N_{ijkt} \leq AV_{jmkt} \quad \forall j \in WH, \forall m \in DA, \forall k \in TM, \forall t \in TIM \quad (20)$$

7) Inventory balance constraints

$$IN_{rj(t-1)} + \sum_{k \in TM} \sum_{i \in S} \sum_{c \in ITU} SULD_{rcijk(t-LT_{ijk})} = IN_{rjt} + \sum_{k \in TM} \sum_{m \in DA} \sum_{c \in ITU} WULD_{rcjmkt} \quad \forall r \in R, \forall j \in WH, \forall t \in TIM \quad (21)$$

$$InZero_{rj} = IN_{rjt} + \sum_{k \in TM} \sum_{m \in DA} \sum_{c \in ITU} WULD_{rcjmk} \quad \forall r \in R, \forall j \in WH, t = 1 \in TIM \quad (22)$$

8) Availability of vehicles constraints

i) Vehicle of Supplier

$$V_{kit} = BS_{ki} \quad \forall i \in S, \forall k \in TM, t = 1 \quad (23)$$

$$V_{kit} = V_{ki(t-1)} - \sum_{j \in WH} VU_{ijk(t-1)}$$

$$\forall i \in S, \forall k \in TM, t = 2 \quad (24)$$

$$V_{kit} = V_{ki(t-1)} - \sum_{j \in WH} VU_{ijk(t-1)} + \sum_{j \in WH} VU_{ijk(t-2LT_{ijk})} \quad \forall i \in S, \forall k \in TM, \forall t > 2 \quad (25)$$

$$V_{kit} \leq BS_{ki} \quad \forall i \in S, \forall k \in TM, \forall t \in TIM \quad (26)$$

$$\sum_{j=1}^J VU_{ijkt} \leq V_{kit} \quad \forall i \in S, \forall k \in TM, \forall t \in TIM \quad (27)$$

$$VU_{ijkt} \leq MO_{ijkt} Q \quad \forall i \in S, \forall j \in WH, \forall k \in TM, \forall t \in TIM \quad (28)$$

ii) Vehicle of Warehouse

$$VE_{kjt} = BW_{kj} \quad \forall j \in WH, \forall k \in TM, t = 1 \quad (29)$$

$$VE_{kjt} = VE_{kj(t-1)} - \sum_{m \in DA} VEU_{jmk(t-1)} \quad \forall j \in WH, \forall k \in TM, t = 2 \quad (30)$$

$$VE_{kjt} = VE_{kj(t-1)} - \sum_{m \in DA} VEU_{jmk(t-1)} + \sum_{m \in DA} VEU_{jmk(t-2L_{jmk})} \quad \forall j \in WH, \forall k \in TM, \forall t > 2 \quad (31)$$

$$VE_{kjt} \leq BW_{kj} \quad \forall j \in WH, \forall k \in TM, \forall t \in TIM \quad (32)$$

$$\sum_{m=1}^M VUE_{jmkt} \leq VE_{kjt} \quad \forall j \in WH, \forall k \in TM, \forall t \in TIM \quad (33)$$

$$VUE_{jmkt} \leq N_{jmkt} Q \quad \forall m \in DA, \forall j \in WH, \forall k \in TM, \forall t \in TIM \quad (34)$$

9) Route selection constraints

i) From supplier to warehouse

$$\sum_{t'=t}^{t'+2LT_{ijk}} MO_{ijkt'} \leq Q \left(V_{kit} - \sum_{j=1}^J MO_{ijkt} \right)$$

$$\forall i \in S, \forall j \in WH, \forall k \in TM, \forall t \in TIM \quad (35)$$

$$\sum_{j \in WH}^J \sum_{i \in S}^I \sum_{t'=t}^{t'+2L_{ijk}} MO_{ijkt'} \leq Q \left(\sum_{i \in S}^I V_{kit} - \sum_{j \in WH}^J \sum_{i \in S}^I MO_{ijkt} \right) \quad \forall k \in TM, \forall t \in TIM \quad (36)$$

$$\sum_{j \in WH}^J \sum_{i \in S}^I MO_{ijkt} \leq \sum_i^I BS_{ki} \quad \forall k \in TM, \forall t \in TIM \quad (37)$$

$$\sum_{j=1}^J MO_{ijkt} \leq V_{kit} \quad \forall i \in S, \forall k \in TM, \forall t \in TIM \quad (38)$$

$$MO_{ijkt} \leq VU_{ijkt} \quad \forall i \in S, \forall j \in WH, \forall k \in TM, \forall t \in TIM \quad (39)$$

ii) From warehouse to disaster area

$$\sum_{t'=t}^{t'+2L_{jmk}} N_{jmkt'} \leq Q \left(VE_{kjt} - \sum_{m=1}^M N_{jmkt} \right) \quad \forall j \in WH, \forall m \in DA, \forall k \in TM, \forall t \in TIM \quad (40)$$

$$\sum_{j \in WH}^J \sum_{m \in DA}^m \sum_{t'=t}^{t'+2L_{jmk}} N_{jmkt'} \leq Q \left(\sum_{j \in WH}^J VE_{kjt} - \sum_{m \in DA}^M \sum_{j \in WH}^J N_{jmkt} \right) \quad \forall k \in TM, \forall t \in TIM \quad (41)$$

$$\sum_{j \in WH}^J \sum_{m \in DA}^M N_{jmkt} \leq \sum_{j \in WH}^J BW_{kj} \quad \forall k \in TM, \forall t \in TIM \quad (42)$$

$$\sum_{j=1}^J N_{jmkt} \leq VE_{kjt} \quad \forall j \in WH, \forall k \in TM, \forall t \in TIM \quad (43)$$

$$N_{jmkt} \leq VUE_{jmkt} \quad \forall m \in DA, \forall j \in WH, \forall k \in TM, \forall t \in TIM \quad (44)$$

10) Loading availability of ITUs

$$SULD_{rcijkt} \leq CITU_{rck} Q \quad \forall r \in ULD, \forall c \in ITU, \forall i \in S, \forall j \in WH, \forall k \in TM, \forall t \in TIM \quad (45)$$

$$WULD_{rcjmkt} \leq CITU_{rck} Q \quad \forall r \in ULD, \forall c \in ITU, \forall m \in DA, \forall j \in WH, \forall k \in TM, \forall t \in TIM \quad (46)$$

11) Mode changing in warehouses

$$MO_{ijkt-LT_{ijk}} + N_{jmk't} \leq MC_{ijkk't} + 1 \quad \forall i \in S, \forall j \in WH, \forall k \in TM, k' \in TM, \forall t \in TIM \quad (47)$$

$$ITUS_{cijkt-LT_{ijk}} + MCW_{kk} \cdot MC_{ijkk't} \leq ITUW_{cjmkk't} + 1$$

$$\forall c \in ITU, \forall i \in S, \forall j \in WH, \forall m \in DA, \forall k \in TM, \forall k' \in TM, \forall t \in TIM \quad (48)$$

12) Non-negativity constraints

$$SULD_{rcijkt}, WULD_{rcjmkt}, SITU_{cijkt}, WITU_{cjmkt}, X_{hijkt}, Y_{hjmkt}, IN_{rjkt}, V_{kit}, VE_{kjt}, VU_{ijkt}, \\ VEU_{jmkt} \in \mathbb{Z}^+ \quad (49)$$

$$MO_{ijkt}, N_{jmkt}, MC_{kk'jt}, ITUS_{cijkt}, ITUW_{cjmkt}, W_{jt} \in \{0,1\} \quad (50)$$

The objective function (1) is the sum of transportation operation cost that consists of cost transportation of ULDs, cross docking, mode, warehouse usage and ULD type assignment and total inventory holding cost over all time periods.

Constraint sets (2) ensure that relief item demand of each disaster area is satisfied in each period. But in this thesis, warehouses do not create demand, demand occurs only in disaster areas. Constraint sets (3) and (4) convert item flows to ULD flows from suppliers-to-warehouses and warehouses-to-disaster areas, respectively. Constraint sets (5) and (6) ensure that the number of ITUs transported from supplier-to-warehouse and warehouse-to-disaster areas respectively can be at most the total ITU capacity of vehicles in a mode used for the selected path. ULD capacities of vehicles are changed according to the number of ITUs transported by the selected transportation mode. Constraint set (7) ensures that the total length of ULDs loaded is at least the total length of ITUs transported by the vehicle. Constraint sets (8) and (9) guarantee if ITU type is not selected for the route and the transportation mode, number of ITUs transported by the transportation mode through that route is zero and vice versa. Constraint set (10) ensures that ITU type can be assigned to one route for each transportation mode and time period. Moreover, constraint set (11) guarantees if route is not assigned with transportation mode; also ITU type is not assigned. Restriction of constraint sets (7), (8), (9), (10) and (11) are for ULD and ITU flows from suppliers to warehouses and these restrictions for flows from warehouses to disaster areas are imposed by constraint sets (12), (13), (14), (15) and (16).

Warehouses can perform inventory holding, cross docking, loading and unloading in this model. Thus, they have a capacity for these operations in our model. Constraint set (17) ensures that the sum of the number of ULDs is transported by transportation

mode departed from supplier its lead time ago and the number of ULD inventory carried from previous period is at least the ULD capacity of warehouse. In the same manner, constraint set (18) ensures that transportation modes departed from suppliers their lead time ago cannot transport ITUs more than the ITU capacity of the warehouse.

To represent resilience, availability of routes and nodes are constructed in binary matrices. This provides to decide which transportation modes and routes are available to transport items for each time period. For example, in order to use airway in a route, there must be airports in both sides of route. In addition, some routes may be disrupted. For this reason, availability constraints for nodes and routes are designed and represented in constraint sets (19) and (20). Inventory balance constraints that are represented in constraint sets (21) and (22) are only for warehouse nodes. And recursive function is based on lead times of transportation modes. On the other hand, vehicle flow is considered in this model and its balance is provided by the availability of vehicles in mode constraints at suppliers and warehouses. Constraint sets (23), (24) and (25) ensure that the number of available vehicles in a mode at a time period is equal to the difference between the sum of number of available vehicles in the same mode at previous time period and the number of vehicles in the same mode used twice of its lead time ago, and number of vehicles in the same mode used in a mode at previous time, for time period 1, 2, and greater than 2 respectively at suppliers. In the same manner, constraint sets (29), (30) and (31) guarantee that vehicles flow in a mode balance at warehouses. Constraint sets (26) and (27) guarantee that the number of available vehicles in a mode cannot be more than the beginning number of vehicles in the same mode and the number of vehicles used in a mode can be at most the number of available vehicles in the same mode at suppliers for each period, respectively. Same restrictions for warehouses are provided by constraint sets (32) and (33). Constraint sets (28) and (34) ensure that suppliers and warehouses cannot use vehicles in a mode, if same mode is not assigned to a route from suppliers to warehouses and warehouses to suppliers.

To select modes and routes according to the lead time of vehicles for different modes from suppliers to warehouses, constraint sets (35), (36), (37), (38) and (39) are defined. Constraint set (35) and (36) guarantee that a mode can be assigned to a route until all vehicles in the same mode are used and if all vehicles in a mode are used, this mode

cannot be assigned to a route until vehicles come back to supplier. Travel times from supplier-to-warehouse and warehouse-to-suppliers are assumed to be the same. Therefore, waiting time to re-assign the same mode takes twice of vehicles lead time of route. Constraint sets (37), (38) and (39) ensure that number of a mode assignment cannot be more than the beginning number of vehicles in the same mode, the number of available vehicles in the mode and number of vehicles used in the mode at a time period. In the same manner, constraint sets (40), (41), (42), (43) and (44) are defined to select modes and routes according to the lead time of vehicles in a mode from warehouses-to-disaster areas.

According to transportation mode specifications, carrying ability of vehicles are changed relatively specifications of transportation units. For example, many planes cannot transport 40-feet container. Similarly, a plane cannot transport all types of ULDs. Thereby, constraint sets (45) and (46) are defined to impose suitable ITU and ULD assignment to transportation modes from suppliers to warehouses and warehouses to disaster areas.

Cross docking operation can be performed at only warehouses. Thus, mode changing can be observed at only warehouses in this model. Constraint set (47) determines mode-changing between two modes, which are from supplier-to-warehouse and warehouse-to-disaster area at each time period. If a mode changing occurs between two same type of transportation modes at a time period, constraint set (48) ensures that ITU type will be transported from warehouse-to-disaster areas has to be the same with the ITU type that was delivered to warehouse by the transportation mode departed from supplier its lead time ago.

The last constraint sets (49) and (50) impose positive integer and binary restrictions on decision variables, respectively.

Conceptual model of problem in Figure 12 is presented again adding decision variables and numerical values in Figure A.1 in Appendix A.

4.2 Integer Programming Model (IPM-II) with Vehicles Represented as Binary Variable

In this model, vehicles are represented as binary variables. Thus, availability of each vehicle can be followed during the time horizon.

The changes and addition of indices, parameters and variables of the second IPM model are presented below:

Sets

VH Set of transportation vehicles which is in $1, \dots, K$

SVH Set of supplier vehicles which is in $1, \dots, SV$

WVH Set of supplier vehicles which is in $SV+1, \dots, K$

HW Set of highway mode vehicles which is in $1, \dots, SHW$ and $SV+1, \dots, WHW$

RW Set of railway mode vehicles which is in $SHW+1, \dots, SRW$ and $WHW+1, \dots, WRW$

SW Set of seaway mode vehicles which is in $SRW+1, \dots, SSW$ and $WRW+1, \dots, WSW$

AW Set of airway mode vehicles (helicopters) which is in $SSW+1, \dots, SAW$ and $WSW+1, \dots, WAW$

AHW Set of airway mode vehicles (air freighters) which is in $SAW+1, \dots, SAHW = SV$ and $WAW+1, \dots, WAHW = K$

$HW, RW, SW, AW, AHW, SVH,$ and $WHV \subset VH$

Other sets are same with the first model. In this first model, k index is element of only set of TM that consists of five transportation modes such as highway, railway, seaway, airway1 (air freighter), airway2 (helicopter).

Parameters

$$SVB_{ki} = \begin{cases} 1 & \text{vehicle } k \text{ of supplier } i \text{ is available at the beginning of period } t=1 \\ 0 & \text{otherwise} \end{cases}$$

$$WVB_{kj} = \begin{cases} 1 & \text{vehicle } k \text{ of warehouse } j \text{ is available at the beginning of period } t=1 \\ 0 & \text{otherwise} \end{cases}$$

Rest of the parameters are the same with the first model. There is only a difference for the k index. All k indexed parameters in the first model differ in definitions as for vehicles in mode k or mode k .

Decision Variables

$$V_{kit} = \begin{cases} 1 & \text{if vehicle } k \text{ in supplier } i \text{ is available at the beginning of time } t \\ 0 & \text{otherwise} \end{cases}$$

$$VE_{kjt} = \begin{cases} 1 & \text{if vehicle } k \text{ in warehouse } j \text{ is available at the beginning of time } t \\ 0 & \text{otherwise} \end{cases}$$

Rest of the decision variables are the same with the first model. There is only a difference for the k index. All k indexed decision variables in the first model differ in definitions as for vehicles in mode k or mode k .

IPM-II

The mathematical formulation of the IPM-II is as follows.

Objective function (Minimize total transportation operation cost and total holding cost)

$$\begin{aligned}
\text{Minimize } & \sum_{k \in AHW \cup AW} \sum_{j \in WH} \sum_{i \in S} \sum_{r \in UL} \sum_{c \in ITU} \sum_{t \in TIM} C_{rijk} SULD_{rcijkt} WEULD_r + \\
& \sum_{k \in AHW \cup AW} \sum_{m \in DA} \sum_{j \in WH} \sum_{r \in UL} \sum_{c \in ITU} \sum_{t \in TIM} CO_{rjmk} WULD_{rcjmkt} WEULD_r + \\
& \sum_{t \in TIM} \sum_{j \in WH} \sum_{r \in UL} IN_{rjt} HO_{rjt} + \sum_{j \in WH} \sum_{k \in SVH} \sum_{k' \in WVH} \sum_{t \in TIM} MC_{jkk't} MCC_{jkk't} + \\
& \sum_{i \in S} \sum_{j \in WH} \sum_{k \in SVH} \sum_{t \in TIM} MO_{ijkt} TQ + \sum_{j \in WH} \sum_{m \in DA} \sum_{k \in WVH} \sum_{t \in TIM} N_{jmkt} TQ + \\
& \sum_{k \in WVH} \sum_{m \in DA} \sum_{j \in WH} \sum_{c \in ITU} \sum_{t \in TIM} CCO_{cjmkt} WITU_{cjmkt} + \sum_{k \in SVH} \sum_{i \in S} \sum_{j \in WH} \sum_{c \in ITU} \sum_{t \in TIM} CC_{cijkt} SITU_{cijkt} + \\
& \sum_{k \in WVH} \sum_{m \in DA} \sum_{j \in WH} \sum_{c \in ITU} \sum_{t \in TIM} ITUW_{cjmkt} TQ + \sum_{k \in SVH} \sum_{i \in S} \sum_{j \in WH} \sum_{c \in ITU} \sum_{t \in TIM} ITUS_{cijkt} TQ + \\
& \sum_{j \in WH} \sum_{t \in TIM} W_{jt} TQ
\end{aligned} \tag{51}$$

Subject to

1) ITU capacity constraints of vehicles

i) From supplier to warehouse

$$SITU_{cijkt} \leq CA_{ck} MO_{ijkt} \quad \forall c \in ITU, \forall i \in S, \forall j \in WH, \forall k \in SVH, \forall t \in TIM \tag{52}$$

ii) From warehouse to disaster area

$$WITU_{cjmkt} \leq CA_{ck} N_{jmkt} \quad \forall c \in ITU, \forall m \in DA, \forall j \in WH, \forall k \in WVH, \forall t \in TIM \tag{53}$$

2) Availability of vehicles constraints

i) Vehicle of Supplier

$$\sum_{j \in WH} MO_{ijkt} \leq V_{kit} \quad \forall i \in S, \forall k \in SVH, t = 1 \tag{54}$$

$$V_{kit} = V_{ki(t-1)} - \sum_{j \in WH} MO_{ijk(t-1)} \quad \forall i \in S, \forall k \in SVH, t = 2 \tag{55}$$

$$V_{kit} = V_{ki(t-1)} - \sum_{j \in WH} MO_{ijk(t-1)} + \sum_{j \in WH} MO_{ijk(t-2LT_{ijk})} \quad \forall i \in S, \forall k \in SVH, \forall t > 2 \tag{56}$$

$$V_{kit} \leq SVB_{ki} \quad \forall i \in S, \forall k \in SVH, \forall t \in TIM \quad (57)$$

$$\sum_{i \in S}^I V_{kit} \leq 1 \quad \forall k \in SVH, \forall t \in TIM \quad (58)$$

ii) Vehicle of Warehouse

$$\sum_{m \in DA}^M N_{jmk} \leq VE_{kjt} \quad \forall j \in WH, \forall k \in WVH, t = 1 \quad (59)$$

$$VE_{kjt} = V_{Ekj(t-1)} - \sum_{m \in DA}^M N_{jmk(t-1)} \quad \forall j \in WH, \forall k \in WVH, \forall t = 2 \quad (60)$$

$$VE_{kjt} = V_{Ekj(t-1)} - \sum_{m \in DA}^M N_{jmk(t-1)} + \sum_{m \in DA}^M N_{jmk(t-2L_{jmk})} \quad \forall j \in WH, \forall k \in WVH, \forall t > 2 \quad (61)$$

$$VE_{kjt} \leq WVB_{kj} \quad \forall j \in WH, \forall k \in WVH, \forall t \in TIM \quad (62)$$

$$\sum_{j \in WH}^J VE_{kjt} \leq 1 \quad \forall k \in WVH, \forall t \in TIM \quad (63)$$

3) Route selection constraints

i) From supplier to warehouse

$$\sum_{t'=t}^{t'+2LT_{ijk}} MO_{ijkt'} \leq Q(1 - MO_{ijkt}) \quad \forall i \in S, \forall j \in WH, \forall k \in SVH, \forall t \in TIM \quad (64)$$

$$\sum_{j \in WH}^J \sum_{i \in S}^I \sum_{t'=t}^{t'+2LT_{ijk}} MO_{ijkt'} \leq Q \left(1 - \sum_{j \in WH}^J \sum_{i \in S}^I MO_{ijkt} \right) \quad \forall k \in SVH, \forall t \in TIM \quad (65)$$

$$\sum_{j \in WH}^J \sum_{i \in S}^I MO_{ijkt} \leq 1 \quad \forall k \in SVH, \forall t \in TIM \quad (66)$$

i) From warehouse to disaster area

$$\sum_{t'=t}^{t'+2L_{ijk}} N_{jmk} \leq Q(1 - N_{jmk}) \quad \forall j \in WH, \forall m \in DA, \forall k \in WVH, \forall t \in TIM \quad (67)$$

$$\sum_{t'=t}^{t'+2L_{ijk}} \sum_{m \in DA}^M \sum_{j \in WH}^J N_{jmkt'} \leq Q(1 - \sum_{j \in WH}^J \sum_{m \in DA}^M N_{jmkt}) \quad \forall k \in WVH, \forall t \in TIM \quad (68)$$

$$\sum_{m \in DA}^M \sum_{j \in WH}^J N_{jmkt} \leq 1 \quad \forall k \in WVH, \forall t \in TIM \quad (69)$$

4) Non-negativity constraints

$$SULD_{rcijkt}, WULD_{rcjmkt}, SITU_{cijkt}, WITU_{cjmkt}, X_{hijkt}, Y_{hjmt}, IN_{rjkt} \in \mathbb{Z}^+ \quad (70)$$

$$V_{kit}, VE_{kjt}, MO_{ijkt}, N_{jmkt}, MC_{kk'jt}, ITUS_{cijkt}, ITUW_{jmkt}, W_{jt} \in \{0,1\} \quad (71)$$

The objective function (51) is the sum of transportation operation cost that consists of cost transportation of ULDs, cross docking, vehicle, warehouse usage and ULD type assignment and also the total inventory holding cost over all time periods.

Constraint sets (2), (3), (4), (7), (8), (9), (10), (11), (12), (13), (14), (15), (16), (17), (18), (19), (20), (21), (22), (45), (46), (47) and (48) are the same with the first model. Different constraint sets are introduced below.

Constraint sets (52) and (53) ensure that the number of ITUs transported from supplier-to-warehouse and warehouse-to-disaster areas respectively can be at most ITU capacity of vehicle used for the selected path. ULD capacities of vehicles are changed according to the number of ITUs transported by the selected vehicle.

Vehicle flow is also considered in this model and its balance is provided by the availability of vehicle constraints at suppliers and warehouses. In these constraints, constraint sets (54), (55) and (56) are for time period 1, 2, and greater than 2 respectively at suppliers. In the same manner, constraint sets (59), (60) and (61) guarantee vehicle flow balance at warehouses. Constraints sets (57) and (58) specify vehicle availability and allocation according to suppliers, respectively. Allocation of vehicles means that a vehicle can be available for only one supplier for each period. Same restrictions for warehouses are provided by constraint sets (62) and (63).

To select vehicles and routes in according to considering lead time of vehicles from suppliers to warehouses, constraint sets (64), (65) and (66) are defined. Constraint sets (64) and (65) guarantee that if a vehicle is assigned to a route at a time period, this vehicle cannot be assigned to same route until it comes back to supplier. Travel times from supplier-to-warehouse and warehouse-to-suppliers are assumed to be the same. Therefore, waiting time to re-assign the same vehicle takes twice of its lead time of route. Constraint set (66) ensures that a vehicle can be assigned to a route once at each time period. In the same manner, to select vehicles and routes in according to considering lead time of vehicles from warehouses-to-disaster areas, constraint sets (67), (68) and (69) are defined.

The last constraint sets (70) and (71) impose positive integer and binary restrictions on decision variables, respectively.

In the first model vehicles are represented by integer variables, but in this model vehicles in a mode are represented as binary variables. Conceptual model of the problem in Figure 12 is presented by using decision variables and numerical values in Figure A.2 in Appendix A.

4.3 Single Mode Modified Integer Programming Model I (IPM-I)

In this thesis, one of the purposes is to show that intermodal transportation is a more efficient for humanitarian logistics than single mode transportation. According to this aim, to show differences of two methods based on performance measures, IPM-I is modified so that warehouse operation is performed only between two same transportation modes (i.e., mode is not changed). To allow mode changing for only the same transportation modes, additional constraint sets are determined. These constraint sets follows

$$MO_{ijkt-LT_{jk}} + N_{jmk't} \leq Q(1 - MC_{ijkk't})$$

$$\forall i \in S, \forall j \in WH, \forall k \neq k', k \text{ and } k' \in TM, \forall t \in TIM \quad (72)$$

$$\sum_{k \in TM} MO_{ijkt} \leq 1 \quad \forall i \in S, \forall j \in WH, \forall t \in TIM \quad (73)$$

$$\sum_{k \in TM} N_{jmk} \leq 1 \quad \forall j \in WH, \forall m \in DA, \forall t \in TIM \quad (74)$$

Constraint set (72) ensures that if a mode changing occurs between two modes at a time period, these modes cannot be the same. Additionally, constraint sets (73) and (74) guarantee that only one type of mode can be used for each route at each time period.

4.3 Complexities of The Models

According to number of decision variables of IPM-I and IPM-II are compared in Table 10. IPM-II has more decision variables since

$$K = KM \times \alpha \text{ and } \alpha > 1,$$

$$SV = KM \times \beta \text{ and } \alpha > \beta > 1.$$

Table 10 Complexities of IPM-I and IPM-II according to decision variables

	IPM-I	IPM-II
MO_{ijkt}	$I \times J \times KM \times T$	$I \times J \times SV \times T$
N_{jmkt}	$J \times M \times KM \times T$	$J \times M \times (K - SV) \times T$
W_{jt}	$J \times T$	$J \times T$
$ITUS_{cijkt}$	$C \times I \times J \times KM \times T$	$C \times I \times J \times SV \times T$
$ITUW_{cjmkt}$	$C \times J \times M \times KM \times T$	$C \times J \times M \times (K - SV) \times T$
$MC_{jkk't}$	$J \times KM \times KM \times T$	$J \times SV \times (K - SV) \times T$
V_{kit}	$I \times KM \times T$	$I \times SV \times T$
VE_{kjt}	$J \times KM \times T$	$J \times (K - SV) \times T$
VU_{ijkt}	$I \times J \times KM \times T$	
VEU_{kjt}	$J \times M \times KM \times T$	
X_{hijkt}	$H \times I \times J \times KM \times T$	$H \times I \times J \times SV \times T$
Y_{hjmkt}	$H \times J \times M \times KM \times T$	$H \times J \times M \times (K - SV) \times T$
$SULD_{rcijkt}$	$R \times C \times I \times J \times KM \times T$	$R \times C \times I \times J \times SV \times T$
$WULD_{rcjmkt}$	$R \times C \times J \times M \times KM \times T$	$R \times C \times J \times M \times (K - SV) \times T$
$SITU_{cijkt}$	$C \times I \times J \times KM \times T$	$C \times I \times J \times SV \times T$
$WITU_{cjmkt}$	$C \times J \times M \times KM \times T$	$C \times J \times M \times (K - SV) \times T$
IN_{rjt}	$R \times J \times T$	$R \times J \times T$
Total # of Binary Variables	$T \times J \times [KM \times [(I + M)(1 + C) + KM] + 1]$	$T \times [J + J \times (K - SV) \times (1 + M + SV + CM) + I \times SV \times (1 + J + CJ)]$
Total # of Integer Variable	$T \times [R \times J + KM \times [I + J + J \times (1 + H + C + R \times C)(I + M)]]$	$T \times [J \times R + (C + H + C \times R) \times ((K - SV) \times J \times M + SV \times I \times J)]$
TOTAL	$T \times [J \times (1 + R) + KM \times [J \times [(2 + C \times (2 + R) + H) \times (I + M) + I + KM] + I]]$	$T \times [J \times (1 + R) + J \times [(SV \times (I - M) + K \times M) \times (2 + C \times (2 + R) + H) + K] + I \times SV]$

Number of constraints of IPM-I and IPM-II are compared in Table 11. IPM-II has more constraints since

$$K = KM \times \alpha \text{ and } \alpha > 1,$$

$$SV = KM \times \beta \text{ and } \alpha > \beta > 1.$$

Table 11 Complexities of IPM-I and IPM-II according to decision variables

MODEL	Constraints
IPM-I	$T_x[2xJ+4xKM+2xIxKM+JxR+JxKMx$ $(6xI+5xM+4xCxI+4xCxM+HxI+IxKM+HxM+CxIxR+CxMxR+CxIxKMxM+I)]$
IPM-II	$T_x[Jx(K-SV) \times (3xM+4xCxM+HxM+IxSV+CxMxR+CxIxMxSV+2)+SVx$ $(2xI+3xIxJ+4xCxIxJ+HxIxJ+CxIxJxR+I)+2xJ+4xK+HxM+JxR]$

As a result of this comparison, IPM-II is more complex than IPM-I.

In a disaster situation, mathematical model type that will be used, can be changed according to their vehicle representation styles. Therefore, advantages and disadvantages are discussed here. IPM-I and IPM-II are compared according to the situation of use. In response phase, response time is very important performance measure in transportation of relief items. Therefore, a feasible or optimal solution have to be obtained immediately for delivery relief items. According to this criteria, IPM-I is less complex than IPM-II, therefore, IPM-I can obtain a solution in a short time. On the other hand, in IPM-I, one of the assumptions is that all vehicles have same capacity and same lead time in a transportation mode, but, in real scenarios, vehicles capacities are differentiated according to their specifications. In this case, IPM-II provides that different capacitated vehicles for the transportation of relief items. In addition to this case, vehicles can be tracked individually in IPM-II. On the other hand, vehicles are represented as fleets in IPM-II. Thereby, vehicles can be tracked as a group. Although IPM-II is more realistic, response time is more important for the humanitarian logistics.

CHAPTER 5

EXPERIMENTAL STUDY

In this chapter, data gathering, results, and comparisons of five scenarios that are designed to observe performance measures of mathematical models are given. Run sets of five scenarios are constructed by using real data to compare scenarios and models. Additionally, results are presented for each model. All runs are performed at a workstation, which has Windows 2012 Server, 88 Gb Ram, Intel Xeon Processor E5-2620 by using GAMS 24.0.2.

In this study, the number of vehicles used, fill rate of vehicles, number of intermodal transportation units (ITU) used, inventory holding and percentage of intermodal transportation usage in delivery of relief items are observed as performance measures to emphasize intermodal transportation in humanitarian logistics. Additionally, cost periods of each scenario are determined and analysed to observe trend of cost line during the time horizon.

5.1 Performance Measures

The performance measures of “number of vehicle used”, “number of intermodal transportation units used”, “fill rate of vehicles”, “number of inventory carried”, “intermodal transportation percentage” and “total transportation and inventory holding cost” are defined and analysed in this study.

“Number of vehicles used” is defined as a decision variable in the mathematical models in this study. In the second model (IPM-II), it is represented as binary variables

V_{kit} and VE_{kjt} that represent availability of vehicles in suppliers and warehouses. If they are zero, this means that vehicles were used. Number of vehicles used can also be calculated from transportation mode and route selection variables MO_{ijkt} and N_{jmkt} in the second model. On the other hand, number of vehicles used is represented as integer variables VU_{kit} and VEU_{kjt} that represent the number of vehicles used in the first model (IPM-I). To minimize the number of vehicles used is one of aims of this study. In the response phase, resources such as transportation vehicles have to be managed efficiently.

“Number of intermodal transportation units” is represented by $SITU_{cijkt}$ and $WITU_{cjmkt}$. These variables refer to the number of 40 feet containers transported from suppliers-to-warehouses and from warehouses-to-disaster areas. In a disaster, a container is a vital resource that is used for transporting, storage and sheltering [66]. Furthermore, using containers in transportation is cheaper, less vulnerable and less product packaging than conventional bulk transportation. Especially in some regions of Turkey, the number of containers is limited. Therefore, our mathematical model keeps at minimum level of the number of transported containers to use the remaining in the regions where sheltering and storage are needed.

“Fill rate of vehicles” refers to the percentage of total length of unit loading devices (ULD) transported to the total length of intermodal transportation units (ITU) transported in each vehicle. It is calculated by the sum of product length of ULDs ($LEULD_r$) and the number of ULDs ($SULD_{rcijkt}$ and $WULD_{rcjmkt}$) transported in the vehicle and dividing the result by the sum of product length of ITUs ($LEITU_c$) and the number of ITUs ($SITU_{cijkt}$ and $WITU_{cjmkt}$) transported in the same vehicle. Then calculation is converted to a percentage. Formulation of “fill rate of vehicles” is:

FR_{kijt} = Fill rate of vehicle k departs items from supplier to warehouse at time t

$$FR_{kijt} = 100 \frac{\sum_{c=1}^C \sum_{r=1}^R SULD_{rcijkt} LEULD_r}{\sum_{c=1}^C SITU_{cijkt} LEITU_c} \quad \forall k \in VH, \forall i \in S, \forall j \in WH, \forall t \in TIM \quad (75)$$

“Number of inventory carried” is represented as an integer variable IN_{ijt} that refers to the number of type r ULD that is carried over from period t to period $t+1$. According to the time periods between demands that will be defined in 5.4 Run Sets section, changing of IN_{ijt} values are observed and analysed. Also, inventory of ULDs provides more resilient transportation for disaster areas because of the lead time of supplier vehicle. Suppliers can transport relief items at most the sums of capacities of available vehicles. Therefore, surplus relief items delivered in previous periods can be transported to disaster areas until suppliers’ vehicles arrive at warehouses.

“Intermodal transportation percentage” refers to the percentage of cross-dock operations between two different transportation modes to all cross dock operations within a time horizon. Cross dock operation is represented as a binary variable $MC_{jkk't}$ ($k' \in WV, WV \subset VH$) that refers to the occurrence of mode changing or not in warehouse j at time t . If vehicle k and vehicle k' belong to different transportation modes, this cross dock operation is performed in intermodal transportation. Hence, formulation of “intermodal transportation percentage” is;

Intermodal transportation percentage =

$$100 \frac{\sum_{t=1}^T \sum_{q'=1}^K \sum_{q=1}^K \sum_{j=1}^J MC_{jqq't}}{\sum_{t=1}^T \sum_{k'=1}^K \sum_{k=1}^K \sum_{j=1}^J MC_{jkk't}} \quad q \in A, q' \in B, A \in VH, B \in VH \text{ and } A \cap B = \emptyset \quad (76)$$

“Total transportation and inventory holding cost” provides to compare IPM-I and single model IPM-I according to their cost performance and observe changes of total cost according to changing other performance measures.

5.2 Scenarios

In this study, five scenarios are tested to observe and compare performance measures of two models. Each scenario consists of five cities and two suppliers, two warehouses and one disaster area. Disaster areas are selected from cities where earthquakes were happened before. In Table 12, scenarios and their cities are presented.

Table 12 Cities of scenarios

Scenario no	Suppliers	Warehouses	Disaster Areas
1	Hamburg İstanbul	İzmir Antalya	Denizli
2	Hamburg Barcelona	İstanbul İzmir	Afyon
3	İzmir Adana	Kayseri K.Maraş	Erzincan
4	İstanbul Bursa	Samsun Eskisehir	Ankara
5	Balıkesir Denizli	İstanbul Bursa	Bolu

Among these cities, there are logistic warehouses already established or under construction by Turkish Disaster and Emergency Management Presidency (DEMP). Also, there are logistic centers of Turkish State Railways (TCDD) already established or under construction in some cities. Cities are presented according to logistic warehouses and roles in scenarios in Table 13 [67] [68]. Especially we focus on logistic centers of TCDD and logistics warehouses of DEMP in cities which have a role in scenarios as a warehouse for this thesis.

Table 13 DEMP and TCDD logistic warehouses of cities.

Cities	DEMP Logistic Warehouse	TCDD Logistic Warehouse	Roles in Scenarios		
			Suppliers	Warehouses	Disaster Areas
Adana	✓		✓		
Afyon	✓				✓
Ankara	✓				✓
Antalya	✓			✓	
Balıkesir	✓	✓	✓		
Barcelona			✓		
Bolu					✓
Bursa	✓		✓	✓	
Denizli	✓	✓	✓		✓
Erzincan	✓				✓
Eskisehir		✓		✓	
Hamburg			✓		
İstanbul	✓	✓	✓	✓	
İzmir		✓	✓	✓	
K.Maraş	✓	✓		✓	
Kayseri		✓		✓	
Samsun	✓	✓		✓	

In this thesis, national and international transportation are considered to deliver disaster relief items. Thereby, two of the scenarios have international suppliers which are Hamburg and Barcelona. Additionally, each transportation mode can be used for at least one route in each scenario. Data gathering for these scenarios are presented in next part of the thesis.

5.3 Data Gathering

In this part, data gathering methods for parameters of mathematical models are explained and necessary assumptions of data sets for five scenarios are made. In this thesis, real data is used for parameters excluding the vehicle numbers at the initial period ($t = 0$).

5.3.1 Demand

Disaster areas of scenarios are selected from cities where earthquake was happened. Demand is an uncertainty for the humanitarian logistics. Therefore, data for disaster relief items determined by using past earthquake data of cities from DEMP database system [69]. Past earthquake data consists of number of hard-hit and destroyed house for determination of relief items demands. Thus we assumed that each destroyed or hard-hit house results with ten numbers of beneficiaries. Another assumption is that

demand occurs for two relief items; tent and blanket. According to DEMP disaster reports for Turkey, five people can shelter in one tent and each person needs two blankets. Determination of demands for tent and blanket according to disaster areas is presented in Table 14.

Table 14 Disaster areas and their demand determinations.

Disaster Type	Date	Magnitude	City	Hard-hit houses	Destroyed house	Number People	Total tent	Total Blanket
Earthquake	1.02.1944	7.2	Bolu	20865	0	208650	41730	417300
Earthquake	19.08.1976	4.9	Denizli	887	0	8870	1774	17740
Earthquake	13.03.1992	6.8	Erzincan	6702	0	67020	13404	134040
Earthquake	1.10.1995	5.9	Afyon	4909	0	49090	9818	98180
Earthquake	20.12.2007	5.3	Ankara	1170	0	11700	2340	23400

5.3.2 Capacities

To define capacities, suitable ULD and ITU types are determined for scenarios. In Turkey and the foreign companies working with Turkey use containers as transportation unit. Thus, to select ITU types, container types are used in Turkey are analysed. 40 feet container has the highest percentage of usage in Turkey and Europe. According to this information, in this thesis, 40-foot dry freight containers are used as ITUs. Its physical properties are shown in Table 15 [70], [71]. Maximum loading capacity of 40-foot dry freight container is 28,750 kg.

Table 15 Specifications of ULDs and ITU

	Length (cm)	Width (cm)	Height(cm)	Volume(m3)	Tara Weight(kg)	Total Weight (kg)
ULD ₁	153.00	156.00	162.00	4.30	87.00	1032
ULD ₂	153.00	156.00	228.00	7.20	176.00	1661
ITU	1203.50	235.00	239.30	67.68	3750.00	

Airplane types used in Turkey are considered while selecting ULD types. Therefore, ULDs used by Turkish Airlines are analysed. In this thesis, two types of ULDs are used in five scenarios. These ULDs are coded by International Air Transport Association (IATA) and their codes are AKE and AKH. Specifications of AKE and

AKH are shown in Figure 14. In this study, ITU capacity is determined according to lengths of AKE and AKH. Only AKH can be loaded in the form of lap-jointed into an ITU. Hence, ULD₂ consists of two lap-jointed AKH. Physical specifications of ULDs are also presented in Table 15.

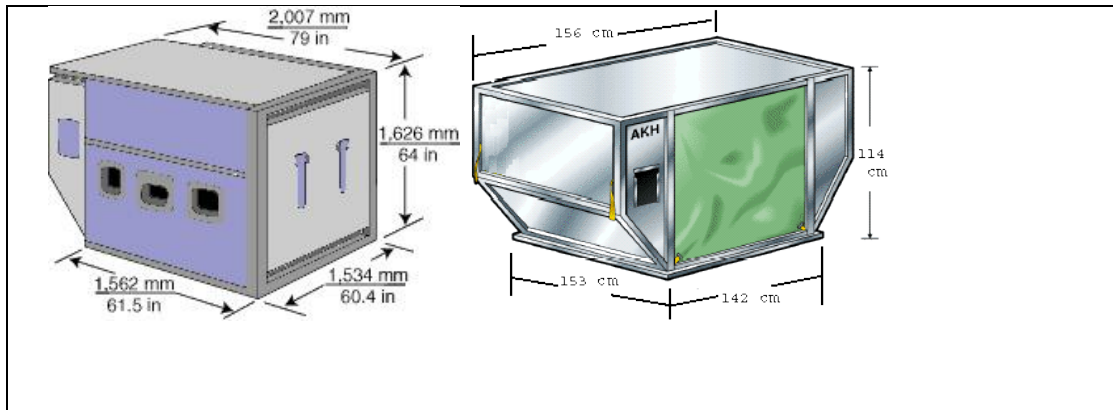

Figure 14 AKE and AKH specifications

Ingredients of ULDs are determined by using physical specifications of tent and blanket. 2000 blanket or 100 tent can be loaded into containers of DEMP. Based upon this experience, volume of tents and blankets are determined to estimate that how many set of items can be loaded into ULDs. As mentioned before in demand section, five people can shelter in a tent and each person needs two blankets. Thus, we assume that in each ULD, blanket/tent ratio is 10. As a result of this determination, ULD₁ and ULD₂ consist of 7 tents with 70 blankets and 11 tents with 110 blankets respectively.

Capacities of warehouses are classified into two areas according to operated load such as ULDs and ITUs. ULD capacities of warehouses are determined according to footprints of ULDs on the container freight stations (CFS) that are loading and unloading container areas of warehouses. Also, ITU capacities of warehouses are determined according to terminal capacity of warehouses in terms of twenty equivalent unit (TEU) that is developed to standardize transportation unit and refers to 20 feet container. In this thesis, ITU capacities of warehouses are considered in terms of 40 feet container after necessary arrangements. ULD and ITU capacities of warehouses are presented in Table 16.

Table 16 Capacities of warehouses

Warehouses		CFS Area (m ²)	Stowage Capacity (TEU)	ULD Capacity	ITU Capacity
Izmir	Aliğa	178934	27728	149936	13864
Antalya	Ortadođu	86800	10000	72733	5000
Istanbul	Ambarlı	224532	80065	188144	40033
Kayseri	Boğazköprü	25812	4000	21629	2000
Maras	Türkođu	375000	15000	314228	7500
Samsun	Samsun	7000	7468	5865	3734
Eskisehir	Hasanbey	365000	14600	305848	7300
Bursa	Gemlik	70000	5228	58655	2614

Vehicle capacities are changed according to transportation modes. In five scenarios, we assumed that capacities of vehicles for a mode are the same. According to transportation modes, vehicle capacities are 1 ITU, 24 ITUs, 500 ITUs, 1 ITU, and 1 ITU for trucks, freight train, container ship, and air freighter and helicopter, respectively [72]. Additionally, two types of ULDs are suitable to transport for ITU and all vehicles.

5.3.3 Costs and Route Availabilities

In disaster management, there is no certain price tariff for transportation operation of relief items. Thereby, price tariffs of operations in commercial logistics are considered in this thesis. Transportation operations consist of three elements in our model such as transportation cost of ITUs and ULDs, mode changing cost and fixed cost for mode selection, warehouse selection and ITU selection. Fixed cost is used for penalizing related decision variables in the objective function. Fixed cost is 350 € per operation that is the cost of customs clearance of Deutsche Post AG (DHL). Additionally, inventory holding cost is determined for ULDs.

Transportation costs of ITUs in seaway, highway and airway modes are determined from DHL domestic and foreign price tariffs [73]. For railway mode, TCDD cargo tariffs are used for domestic railway transportation [74]. In this thesis, two types of airway modes are considered according to the vehicle used such as airplane and helicopter. Transportation costs for airway mode with helicopters are assumed to be same with transportation costs of airplanes. Also, transportation costs of vehicles in

the same transportation modes are assumed to be the same with each other. Additionally, costs for highway and seaway, fully loaded prices of Deutsche Post AG (DHL) are considered.

The cost units differ according to transportation modes. For cost of national airway transportation, domestic cargo price tariffs of Turkish Airlines (abbreviated as THY in Turkish) are used and their cost unit is Turkish Lira (TL) per kg [75]. Unit of cost of airway modes are \$ per kg and € per kg. Similarly, units of cost of other transportation modes are converted according to domestic or foreign such as TL per ton, \$ per container, € per container. In this thesis, monetary units for cost of transportation modes excluding airway modes are converted to TL per container. Because of the transporting ability of vehicles in airway modes mentioned in problem definition section, units of cost of them are converted to TL per kg. Exchange rates of the Central Bank of the Republic of Turkey (CBRT) in 02.11.2015 are considered while converting cost units of all parameters. Transportation costs according to routes and transportation modes are presented in Table 17.

Table 17 Transportation costs according to routes and transportation modes

Cities		Highway		Water		Rail		Airway	
From	To	Price	Unit	Price	Unit	Price	Unit	Price	Unit
Hamburg	İzmir	2500	€/container	800	€/container	-	-	1.54	€/Kg
Hamburg	Antalya	3000	€/container	975	€/container	-	-	1.74	€/Kg
İstanbul	İzmir	1200	TL/container	500	\$/container	67.81	TL/ton	1.66	TL/Kg
İstanbul	Antalya	2000	TL/container	500	\$/container	48.69	TL/ton	1.66	TL/Kg
Hamburg	İstanbul	2200	€/container	750	€/container	-	-	1.44	€/Kg
Barcelona	İzmir	3200	€/container	600	€/container	-	-	2.86	€/Kg
Barcelona	İstanbul	3000	€/container	575	€/container	-	-	2.15	€/Kg
İzmir	Kayseri	2300	TL/container	-	-	90.56	TL/ton	2.21	TL/Kg
İzmir	K.Maraş	2500	TL/container	-	-	102.68	TL/ton	2.21	TL/Kg
Adana	Kayseri	900	TL/container	-	-	26.66	TL/ton	2.21	TL/Kg
Adana	K.Maraş	900	TL/container	-	-	18.82	TL/ton	2.21	TL/Kg
İstanbul	Samsun	2300	TL/container	-	-	118.83	TL/ton	1.66	TL/Kg
İstanbul	Eskişehir	800	TL/container	-	-	23.52	TL/ton	1.66	TL/Kg
Bursa	Samsun	2700	TL/container	625	\$/container	-	-	-	-
Bursa	Eskişehir	900	TL/container	-	-	-	-	-	-
Balıkesir	İstanbul	775	TL/container	-	-	48.69	TL/ton	-	-
Balıkesir	Bursa	500	TL/container	-	-	-	-	-	-

Table 17(cont). Transportation costs according to routes and transportation modes

Cities		Highway		Water		Rail		Airway	
From	To	Price	Unit	Price	Unit	Price	Unit	Price	Unit
Denizli	İstanbul	2000	TL/container	-	-	57.16	TL/ton	1.66	TL/Kg
Denizli	Bursa	1200	TL/container	-	-	-	-	-	-
İzmir	Denizli	750	TL/container	-	-	25.09	TL/ton	2.21	TL/Kg
Antalya	Denizli	1200	TL/container	-	-	17.25	TL/ton	2.21	TL/Kg
İzmir	Afyon	850	TL/container	-	-	33.17	TL/ton	-	-
İstanbul	Afyon	1100	TL/container	-	-	36.46	TL/ton	-	-
Kayseri	Erzincan	1400	TL/container	-	-	39.75	TL/ton	2.21	TL/Kg
K.Maraş	Erzincan	1450	TL/container	-	-	47.2	TL/ton	2.21	TL/Kg
Samsun	Ankara	1800	TL/container	-	-	76.93	TL/ton	1.66	TL/Kg
Eskişehir	Ankara	750	TL/container	-	-	18.82	TL/ton	2.21	TL/Kg
İstanbul	Bolu	1600	TL/container	-	-	-	-	-	-
Bursa	Bolu	1400	TL/container	-	-	-	-	-	-

Inventory holding cost changes according to warehouses on ports and rail terminals. We assumed that inventory holding costs of items are the same for every period. Holding costs are determined by using price tariffs according to cities of shipping companies and TCDD. Inventory holding costs of cities are shown in Table 18. In this thesis, inventory holding cost is the same for both of the two ULD types.

Table 18 Inventory holding cost of cities.

Warehouse Cities	Holding cost	Unit	References
İzmir	12	\$/ULD/day	[76]
Antalya	13.75	\$/ULD/day	[77]
İstanbul	25	\$/ULD/day	[78]
Kayseri	13.5	TL/ULD/day	[79]
K.Maraş	13.5	TL/ULD/day	[79]
Samsun	8	\$/ULD/day	[80]
Eskişehir	13.5	TL/ULD/day	[79]
Bursa	18	\$/ULD/day	[81]

Mode changing costs are determined by using operation price tariff of a shipping company according to transportation modes and they are the same for all scenarios and warehouses [82]. In this thesis, air freighter can transport relief items into ULDs and

it transports ULDs in unit of kgs. Thereby, operations for unloading and loading change according to transportation modes changes at warehouses.

Table 19 Mode changing cost

Arrival	Departure					Unit
	Highway	Railway	Airway	Seaway	Helicopter	
Highway	140	308	645	322	645	TL/Mode changing
Railway	308	266	645	322	645	TL/Mode changing
Airway	645	645	322	645	645	TL/Mode changing
Seaway	322	322	645	266	645	TL/Mode changing
Helicopter	645	645	645	645	308	TL/Mode changing

In Table 19, mode changing costs are presented according to transportation modes. For instance, mode changing between highway and airway transportation mode consists of two operations such as unloading ULDs from ITUs and reloading ULDs into air freighter. Another example is that mode changing operations differ between seaway-to-seaway and seaway-to-highway by reason of using landing stage extra in mode changing from seaway to highway.

Route availabilities are dependent on whether necessary terminals are in cities or not. Thus, availability of routes binary matrix is determined with related to transportation cost data in Table 19. If there is no service between two cities for a transportation mode, matrix value between these cities is zero. In five scenarios, unavailability of the routes that might be caused by the disaster is not considered. Therefore, availabilities of routes are same with their situation at the beginning of time horizon for five scenarios. Additionally, we assumed that helicopters are available for all cities and scenarios.

5.3.4 Transportation Lead Time and Time Periods

In our model, every transportation mode has different lead times for the same destination according to their vehicle types. On the other hand, we assumed that travel

times of round-trip of vehicles are twice the travel time of a one-way trip either way. In the light of this assumption, lead times are determined according to distances between cities and average running speeds of vehicle types. Some of these lead times are obtained from DHL, TCDD and THY directly [73] [74] [75]. After determination of lead times, lead times are converted in terms of time periods.

Planning horizon refers to the first five days in response phase. Thus it consists of 120 hours and it is divided into time periods equally. Time periods are determined according to the lead times of vehicles and average response time when a disaster occurs. Then, we determined that one time period consists of five hours. Hence, there are 24 time periods in the planning horizon. Lead times of transportation modes according to cities are presented in Table 20.

Table 20 Lead times of transportation modes according to cities.

From	To	Highway (time period)	Seaway (time period)	Airway (time period)	Railway (time period)
Hamburg	Izmir	24	86	5	-
Hamburg	Antalya	29	96	7	-
Hamburg	Istanbul	19	72	5	-
Barcelona	Izmir	38	29	10	-
Barcelona	Istanbul	34	34	7	-
Istanbul	Izmir	2	5	1	4
Istanbul	Antalya	2	10	1	3
Izmir	Kayseri	2	-	1	4
Izmir	Maras	3	-	1	5
Adana	Kayseri	1	-	1	1
Adana	Maras	1	-	1	1
Istanbul	Samsun	2	-	1	6
Istanbul	Eskisehir	1	-	1	1
Bursa	Samsun	2	10	-	-
Bursa	Eskisehir	1	-	-	-
Balikesir	Istanbul	1	-	-	3
Balikesir	Bursa	1	-	-	-
Denizli	Istanbul	2	-	1	3
Denizli	Bursa	1	-	-	-
Izmir	Denizli	1	-	1	1
Antalya	Denizli	1	-	1	1
Izmir	Afyon	1	-	-	2
Istanbul	Afyon	1	-	-	2
Kayseri	Erzincan	1	-	1	2
Maras	Erzincan	2	-	1	2
Samsun	Ankara	1	-	1	4
Eskisehir	Ankara	1	-	1	1
Istanbul	Bolu	1	-	-	-
Bursa	Bolu	1	-	-	-

5.3.6 Number of Vehicles and Inventory at The Beginning

Number of vehicles at the beginning of the planning horizon refers to transportation capacities of suppliers and warehouses. During the time horizon, suppliers and warehouses can use at most number of their vehicles at the beginning of the time horizon. Thereby, determination of vehicle number is very important to find a feasible solution of scenarios. We assumed that vehicle numbers in a mode are the same for each supplier and warehouse such as warehouses have five trucks for each, suppliers also have five trucks for each. In IPM-II (vehicles are represented by binary variables), total number of vehicle at the beginning of the time horizon is determined by counting the k index. Total number of vehicles at the beginning of the time horizon is the result of $\sum_{k \in TM} (\sum_{i \in S} SVB_{ki} + \sum_{j \in WH} WVB_{kj})$. These values are altered in each run set of scenarios.

For run sets of 40 vehicles, vehicles are allocated according to suppliers and warehouses. Allocation of 40 vehicles is presented in Table 21.

Table 21 Allocation of 40 vehicles

	Truck	Container Ship	Freight Train	Air Freighter	Helicopter	Total
Supplier1	2	2	2	2	2	10
Supplier 2	2	2	2	2	2	10
Warehouse 1	2	2	2	2	2	10
Warehouse 2	2	2	2	2	2	10
Total	8	8	8	8	8	40

As is seen in Table 21, vehicle sources are allocated to suppliers and warehouses equally. To observe changing of performance measures related to vehicle numbers, vehicle numbers are increased to 92, 412, 872 and 2032 in this thesis. Allocation of 92 vehicles is presented in Table 22.

Table 22 Allocation of 92 vehicles

	Truck	Container Ship	Freight Train	Air Freighter	Helicopter	Total
Supplier1	5	3	5	5	5	23
Supplier 2	5	3	5	5	5	23
Warehouse 1	5	3	5	5	5	23
Warehouse 2	5	3	5	5	5	23
Total	20	12	20	20	20	92

Rest of allocations of vehicle sources are presented in Table B.1 in Appendix B

For five scenarios, we assumed that beginning inventory is zero for each type ULDs at warehouses.

5.4 Experimental Sets

To observe and compare performance measures of model, 490 run sets are prepared. Run sets of five scenarios are classified according to vehicle representation style, number of demand occurrence during the time horizon, total number of vehicle at the beginning of the time horizon. We assume that amount of demand at each period is equal for all scenarios. Thereby, the demands that are presented in Table 23, are divided into equal parts, such as 3 parts and 5 parts for each scenario.

Table 23 Run sets of IPM-I, IPM-II and Single model IPM-I

Model Type	# of Vehicle	# of Distinct Period Demand	Start of Demand	Scenarios	Optimal Solution Percentage
IPM-I	40	3	4	All	34%
			16	S2	0%
	92	3	4	All	60%
			16	S2	0%
		5	4	All	60%
			16	All	60%
	412	3	4	All	60%
			16	All	70%
		5	4	All	76%
			16	All	80%
872	3	4	S5	100%	
2032	3	4	S5	100%	
IPM-II	40	3	4	All	38%
	92	3	4	All	60%
Single mode IPM-I	92	3	4	All	60%
			16	S2	0%
	412	3	4	All	70%
			5	4	All
		16		All	70%
	2032	3	4	S5	0%

In Table, all run sets and percentages of optimal solution for the three models are presented. According to Table, to compare solutions and effectiveness of IPM-I and IPM-II, number of vehicles are increased. Also, to obtain feasible solution for the scenario 2 and 5, starting demand periods are changed. Therefore, we observed that Solutions of the two models are same excluding execution time. As a result of this, we considered in comparison of IPM-I and single mode IPM-I to observe changes of performance measures in next chapter. To observe and analyse changes in performance measures on the basis of scenarios, experiment sets are modified according to results of run sets. By using same number of vehicles and period criteria, different run sets are constructed while increasing the number of demand occurrence during the planning horizon. According to the assumption of uniform occurrence of demands among

periods, maximum number of periods between two demands is four if run set consists of five demands that occur for an equal number of items.

Run sets are also classified according to number of periods between demands to observe changes of cost and execution time with demand occurrence. Time period between two demand occurrences is increased linearly until last demand occurs at the last period. Increasing period between two demands are shown in Figure 15.

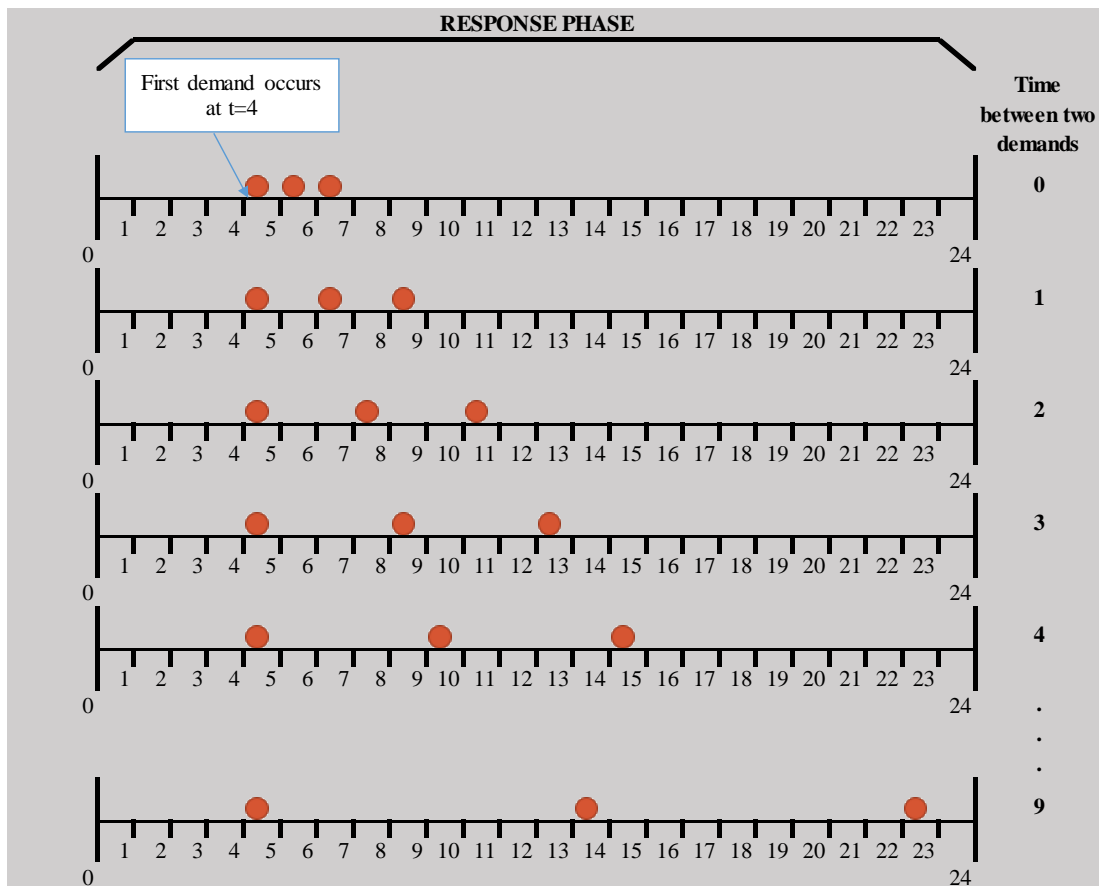

Figure 15 Time between two demands

According to Figure 15, if demand occurs at sixteenth period, at most four run sets can be constructed for each scenario because of the assumption of uniform occurrence.

5.4.5 Constructing Run Sets

Run sets consists of GAMS model files and MS Excel data files. Each GAMS model file has an associated MS Excel data file. Therefore, 491 model file and 491 data file are constructed in total. In order to construct these data files, Visual Basic for

Application (VBA) in Excel is used. In VBA Excel two data constructors are designed and coded for IPM-II and IPM-I. In Figure 16, user form for IPM-I is shown.

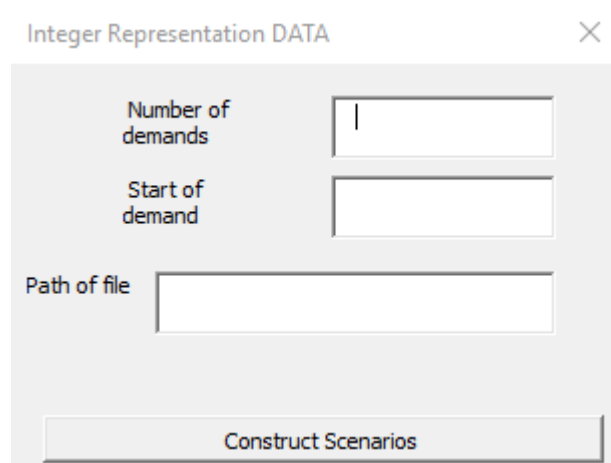

Figure 16 User form of data constructor for integer representation.

In data constructor for integer representation, if number of demands and starting period are entered, data constructor prepares data files for all scenarios by increasing the number of period between two demands. For instance, for three demands which occur at period 3 firstly, data constructor prepares 10 data file for each scenario.

Different from integer representation, in binary representation, number of vehicles should be entered for suppliers and warehouses. Tables for model file should be changed since each vehicle refers to an index. For instance, 92 vehicles mean that size of mode changing is 46×46 . User form of binary representation is presented in Figure 17.

Figure 17 User form of data constructor for binary representation.

After preparation of data files, GAMS files are constructed according to data files. To construct GAMS files, a package program is designed and coded in C#. User form of the GAMS file constructor is shown in Figure 18.

Figure 18 User form of GAMS model file constructor

5.5 Results and Comparisons

In this section, results obtained from run sets defined in Section 5.4 are discussed and compared. Results are reported for each of the mathematical models. Additionally, performance measures of run sets are discussed and compared based on scenarios. Lastly, intermodal IPM-I and single modal IPM-I are compared according to the results and performance measures based on the scenarios.

5.5.1 Results of IPM-II

i. Run Sets with 3 Demands Occurrence and 40 Vehicles

In this thesis, for delivery of relief items with intermodal freight transportation (IFT) a model with binary representation of vehicles (IPM-II) was developed at first. IPM-II was tested with run sets of 40 vehicles. According to the results of these run sets, it is observed that 40 vehicles are not enough to transport relief items to disaster areas on time. Due to the lack of vehicle sources of suppliers and warehouses, feasible solution was not found for scenario 1, 2 and 5. In scenarios 3 and 4, optimum solution was obtained for each run set. As an example of run sets for 40 vehicles, results of run sets with 3 demands for scenario 3 are presented Table 24.

Table 24 Cost and completion time results of scenario 3 with 3 demand, 40 binary vehicle

# of period between demands	start of demand	optimal	relative gap	absolute gap	cost (TL)	computation time (second)
0t	t4	0			0.00	105.74
1t	t4	1	0	0	1085980.95	8114.34
2t	t4	1	0	0	1017366.69	8137.40
3t	t4	1	0	0	443076.57	8123.91
4t	t4	1	0	0	443076.57	8125.74
5t	t4	1	0	0	443076.57	8137.85
6t	t4	1	0	0	443076.57	8130.29
7t	t4	1	0	0	443076.57	8149.66
8t	t4	1	0	0	443076.57	8120.57
9t	t4	1	0	0	443076.57	8130.17

Additionally, for scenario 2, run sets with 3 demands that occur from the sixteenth period forward are tested. These run sets are resulted in infeasibility for each instance. After experiment with 40 vehicles, to obtain a feasible solution, number of vehicles was increased to 92.

ii. Run Sets with 3 Demand and 92 Vehicles

Run sets with 3 demand that occurs from period four forward are tested for 92 vehicles. We obtained optimum solutions for scenarios 1, 3 and 4. Scenario 2 consists of two international suppliers (Hamburg and Barcelona) and minimum lead time of them is five time periods that equal to 25 hours. However, the first demand occurs at the fourth period. Thus, run sets with 3 for 92 vehicles are infeasible for scenario 2. Also, we did not obtain any feasible solution for scenario 5 from run sets for 92 vehicles. Amount of demand in scenario 5 is more than others. Because of route availability, lead times and number of vehicles, demand of scenario 5 cannot be satisfied. In scenario 5, *IPM-1* could assign railway to transport items from Balıkesir or Denizli to Bursa or İstanbul, but railway is not available from Bursa or İstanbul to Bolu. As a result of this, vehicle sources and suppliers have important roles in disaster management. As an example of run sets for 92 vehicles, results of run sets with 3 demands and starting period four for scenario 4 are presented Table 25.

Table 25 Cost and completion time results of scenario 3 with 3 demand, 40 binary vehicle

# of period between demands	start of demand	optimal	relative gap	absolute gap	cost	completion time
0t	t4	1	0	0	36522.72	8160.34
1t	t4	1	0	0	37744.82	553.82
2t	t4	1	0	0	37744.82	5251.28
3t	t4	1	0	0	37744.82	5078.74
4t	t4	1	0	0	37744.82	6656.90
5t	t4	1	0	0	37744.82	8124.37
6t	t4	1	0	0	37744.82	635.05
7t	t4	1	0	0	37744.82	8136.85
8t	t4	1	0	0	37744.82	2051.28
9t	t4	1	0	0	37744.82	8144.65

In a similar way with run sets for 40 vehicles, run sets with 92 vehicles and 3 demands that occur from the sixteenth period forward are solved for scenario 2. In this experiment, we did not obtain feasible solution for each instance because of insufficient number of vehicles.

To show all solution of a scenario, solution of run set with 92 vehicles and 3 demands that occur from period four to seven for scenario 1 (92BV3D0T4) is illustrated by Tables. Total cost and total completion time of 92V3D0T4 are obtained 101405.5 TL and 160.508 seconds respectively. Amount of flow items (X_{hijkt}) from suppliers to warehouses are shown in Table 26.

Table 26 Amount of flow items from suppliers for run set 92BV3D0T4

Item	Supplier	Warehouse	Vehicle	Number of Items Period 1
tent	Istanbul	Izmir	truck6	77
tent	Istanbul	Izmir	truck7	77
tent	Istanbul	Izmir	truck8	77
tent	Istanbul	Izmir	truck9	77
tent	Istanbul	Izmir	truck10	77
tent	Istanbul	Izmir	air6	53
tent	Istanbul	Izmir	air7	77
tent	Istanbul	Izmir	air8	77
tent	Istanbul	Antalya	rail8	1188
blanket	Istanbul	Izmir	truck6	770
blanket	Istanbul	Izmir	truck7	770
blanket	Istanbul	Izmir	truck8	770
blanket	Istanbul	Izmir	truck9	770
blanket	Istanbul	Izmir	truck10	770
blanket	Istanbul	Izmir	air6	530
blanket	Istanbul	Izmir	air7	770
blanket	Istanbul	Izmir	air8	770
blanket	Istanbul	Antalya	rail8	11880

According to Table 26, from supplier to warehouses, 5 trucks, 3 air freighters and 1 freight train are used for delivery of 1780 tents and 17800 blankets. *IPM-II* model assigned only İstanbul to transport items and two warehouses İzmir and Antalya to cross dock. Railway is used only between İstanbul and Antalya. As is seen in Table

27, *IPM-II* model assigned only railway transportation from warehouses to disaster area at start of period 1, 4 and 5.

Table 27 Amount of flow items from warehouses for run set 92BV3D0T4

Item	Supplier	Warehouse	Vehicle	Number of Items		
				Period 1	Period 4	Period 5
tent	Izmir	Denizli	rail11	592		
tent	Antalya	Denizli	rail16			594
tent	Antalya	Denizli	rail18		594	
blanket	Izmir	Denizli	rail11	5920		
blanket	Antalya	Denizli	rail16			5940
blanket	Antalya	Denizli	rail18		5940	

From warehouses to disaster area, 1780 tents and 17800 blankets are transported by three freight trains. After transportation of items, warehouses hold inventory of unit loading devices (ULDs) in their depots. Inventory of ULDs are presented in Table 28.

Table 28 Number of inventory carried by warehouses in 92BV3D0T4.

ULD Type	Warehouse	Number of ULDs	
		Period 2	Period 4
ULD1	Izmir	6	
ULD2	Izmir	15	
ULD2	Antalya		54

According to Table 28, *IPM-II* model used both of warehouses to store ULDs at period 2 and 4 and stored 75 ULDs during the time horizon.

Availabilities of vehicles represented by binary variables V_{kit} and VE_{kjt} in *IPM-II* model. To observe availabilities of vehicles, data can be shown in Table 29, was analysed.

Table 29 Availabilities of vehicles at suppliers in 92BV3D0T4.

Availabilities of Vehicles								
Vehicle	Supplier	Period 1	Period 2	Period 3	Period 4	Period 5	Period 6	Period 7
truck6	Istanbul	✓	✗	✗	✗	✓	✓	✓
truck7	Istanbul	✓	✗	✗	✗	✓	✓	✓
truck8	Istanbul	✓	✗	✗	✗	✓	✓	✓
truck9	Istanbul	✓	✗	✗	✗	✓	✓	✓
truck10	Istanbul	✓	✗	✗	✗	✓	✓	✓
rail8	Istanbul	✓	✗	✗	✗	✗	✗	✓
air6	Istanbul	✓	✗	✓	✓	✓	✓	✓
air7	Istanbul	✓	✗	✓	✓	✓	✓	✓
air8	Istanbul	✓	✗	✓	✓	✓	✓	✓
Helicopter9	Istanbul	✓	✓	✓	✓	✓	✓	✓

As is seen in Table 29, vehicles are assigned to deliver relief items as in Table 26, are available to transport items at the beginning of period 1. Vehicles are used at period 1, are not available until they turn back to suppliers. This time is taken as double of the lead time of vehicles according to their destinations. For example, lead time of truck 6 from İstanbul to İzmir (it can be seen in Table 20) is 2 time periods that equal to 10 hours and truck 6 is used at period 1. It will be available again at period 5. After period 7, all vehicles are available until the period 24. Availabilities of vehicles at warehouses are shown in Table 30. In warehouses, only railway was used to deliver relief items to disaster area and its vehicles can deliver items in one period. Therefore, freight trains 11, 16 and 18 are not available at period 4, 6 and 5 respectively.

Table 30 Availabilities of vehicles at warehouses in 92BV3D0T4.

Availabilities of Vehicles								
Vehicle	Warehouse	Period 1	Period 2	Period 3	Period 4	Period 5	Period 6	Period 7
rail11	Izmir	✓	✓	✓	✗	✓	✓	✓
rail15	Izmir	✓	✓	✓	✓	✓	✓	✓
rail16	Antalya	✓	✓	✓	✓	✓	✗	✓
rail18	Antalya	✓	✓	✓	✓	✗	✓	✓

Warehouses are used for storing and cross-docking in this thesis. Thus, using warehouse data is represented by binary variables W_{jt} in *IPM-II* model. Using warehouses are illustrated in Table 31.

Table 31 Warehouse usage in 92BV3D0T4.

Warehouse	Period 2	Period 3	Period 4	Period 5
Izmir	1	1		
Antalya			1	1

In Table 31, “1” refers to warehouse that is used at that period. Hence, İzmir is used two times at periods 2 and 3. Antalya is also used at periods 4 and 5.

Mode changing is represented by binary variables $MC_{kk'jt}$ in *IPM-I* model and it also gives percentage of intermodal transportation usage. Percentage of intermodal transportation usage is the performance criteria for this thesis since one of purposes of this study is to show positive effects of intermodal transportation on humanitarian logistics. Thus, to determine percentage of intermodal transportation usage equation (73) that is defined in section of performance criteria was used. Changing of modes are shown in Table 32.

Table 32 Mode changing in 92BV3D0T4

Warehouse	Arrival Vehicle	Departure Vehicle	Period 3	Period 4	Intermodal cross-docking
Izmir	truck6	rail11	1		✓
Izmir	truck7	rail11	1		✓
Izmir	truck8	rail11	1		✓
Izmir	truck9	rail11	1		✓
Izmir	truck10	rail11	1		✓
Antalya	rail8	rail18		1	✗

According to Table 32, six mode changes occurred during the time horizon and five of them are intermodal mode changes due to the cross-docking between two different modes. As a result of this, 83.3 % of transportation usage is intermodal.

Another performance measure is number of intermodal transportation unit (ITU) used, which is determined from integer variables $SITU_{cijkt}$ and $WITU_{cjmkt}$ in this thesis. Number of ITU used for transportation from suppliers to warehouses is presented in Table 34.

Table 33 Number of ITU used to transport ULDs from suppliers to warehouses in 92BV3D0T4

ITU type	Supplier	Warehouse	Vehicle	Period 1
ITU1	Istanbul	Izmir	truck6	1
ITU1	Istanbul	Izmir	truck7	1
ITU1	Istanbul	Izmir	truck8	1
ITU1	Istanbul	Izmir	truck9	1
ITU1	Istanbul	Izmir	truck10	1
ITU1	Istanbul	Izmir	air6	1
ITU1	Istanbul	Izmir	air7	1
ITU1	Istanbul	Izmir	air8	1
ITU1	Istanbul	Antalya	rail8	16

Number of ULD used is represented by integer variables $SULD_{rcijkt}$ and $WULD_{crjmk}$ in IPM-II. ULD capacity of ITU is 7 for each ULD types. To determine fill rate of vehicles, numbers of ULD and ITU used are obtained from solution of 92BV3D0T4. Number of ULD used to transport relief items from suppliers to warehouses is presented in Table 34.

Table 34 Number of ULD used from supplier to warehouse in 92BV3D0T4

ITU type	ULD type	Supplier	Warehouse	Vehicle	Period 1
ITUT1	ULDT1	Istanbul	Izmir	air6	6
ITUT1	ULDT2	Istanbul	Izmir	truck6	7
ITUT1	ULDT2	Istanbul	Izmir	truck7	7
ITUT1	ULDT2	Istanbul	Izmir	truck8	7
ITUT1	ULDT2	Istanbul	Izmir	truck9	7
ITUT1	ULDT2	Istanbul	Izmir	truck10	7
ITUT1	ULDT2	Istanbul	Izmir	air6	1
ITUT1	ULDT2	Istanbul	Izmir	air7	7
ITUT1	ULDT2	Istanbul	Izmir	air8	7
ITUT1	ULDT2	Istanbul	Antalya	rail8	108

According to Tables 33 and 34, air 6 transported six ULD1 and one ULD2 from İstanbul to İzmir so that it transported 7 ULDs totally. Also, air 6 can transport maximum 7 ULDs. Thereby, fill rate of air 6 at period 1 is 100%. Numbers of ULD

and ITU used to transport relief items from warehouses to disaster area is presented in Table B.2 and Table B.3 in Appendices B.

Period costs of run sets are also determined to observe changing cost according to time period for each scenario. Period costs for 92BV3D0T4 is presented in Figure 19. As is seen in Figure 19, costs have decreasing trend. In the first period, model try to satisfy demands of more than one period by using more expensive transportation mode than railway. Hence, by using inventory, it can use railway that is cheaper but slower than others to transport relief item demands of next period. Based on this, intermodal transportation provides flexibility for delivery of relief items and does not have to transport relief items with same mode during the time horizon for delivery on time.

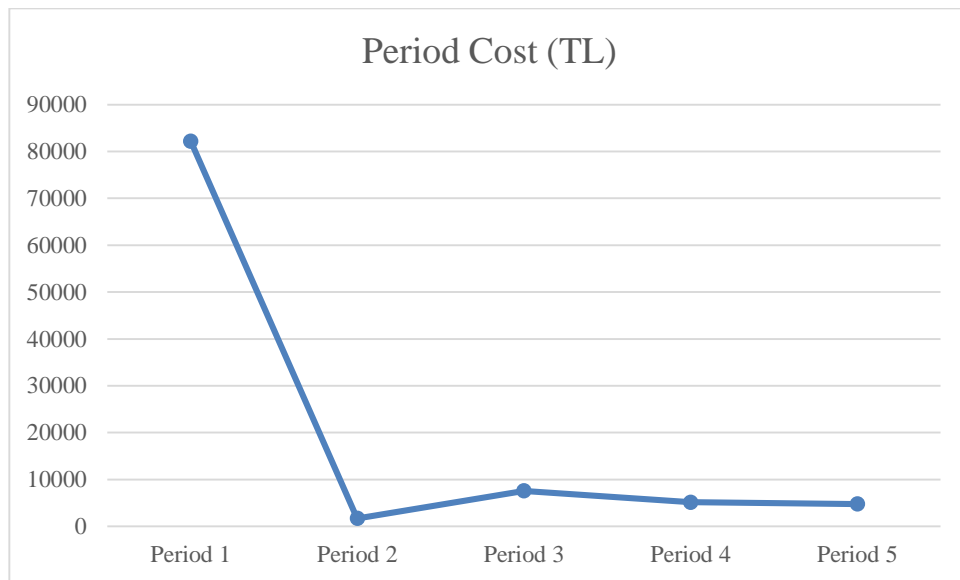

Figure 19 Period Costs of 92BV3D0T4

5.5.2 Results of IPM-I

Increasing number of vehicles in *IPM-II* model increases the run time and to take much more time for execution. Therefore, a more powerful model *IPM-I* is developed to execute run sets in shorter time. Solutions of *IPM-I* are explained briefly.

i. Run Sets with 3 Demands and 40 Vehicles

Run sets with three demands occurrence and 40 vehicles are tested for comparisons with *IPM-II*. Run sets of *IPM-I* for scenarios 1, 2 and 5 are also infeasible. For scenario 2, starting period is shifted to sixteenth period to obtain feasible solution. However, all

instances result in infeasible solution. As an example, total costs and completion time of run sets with three demands occurrence and 40 vehicles for scenario 3 are presented Table B.4 in Appendices B.

ii. Run Sets with 3 Demands 92, 412, 872 and 2032 Vehicles

Solutions of run sets with 3 demands, 92 vehicles that are represented as integers, and starting from fourth period are same with the IPM-II. Solutions are obtained from run sets for scenario 2 and 5 are infeasible for each instances. IPM-II and IPM-I have same solution space excluding total cost. Total cost of two model differ since their vehicle representation style are different. Mode changing costs penalize each mode changings for IPM-I but for IPM-II, they penalize each changing of vehicle at warehouses. Thereby, scenario 1, 3, 4 are compared with the IPM-II in according to execution time of run sets. Comparison of IPM-II and IPM-I according to execution time of run sets for scenario 1, 3 and 4 is presented in Figure 20.

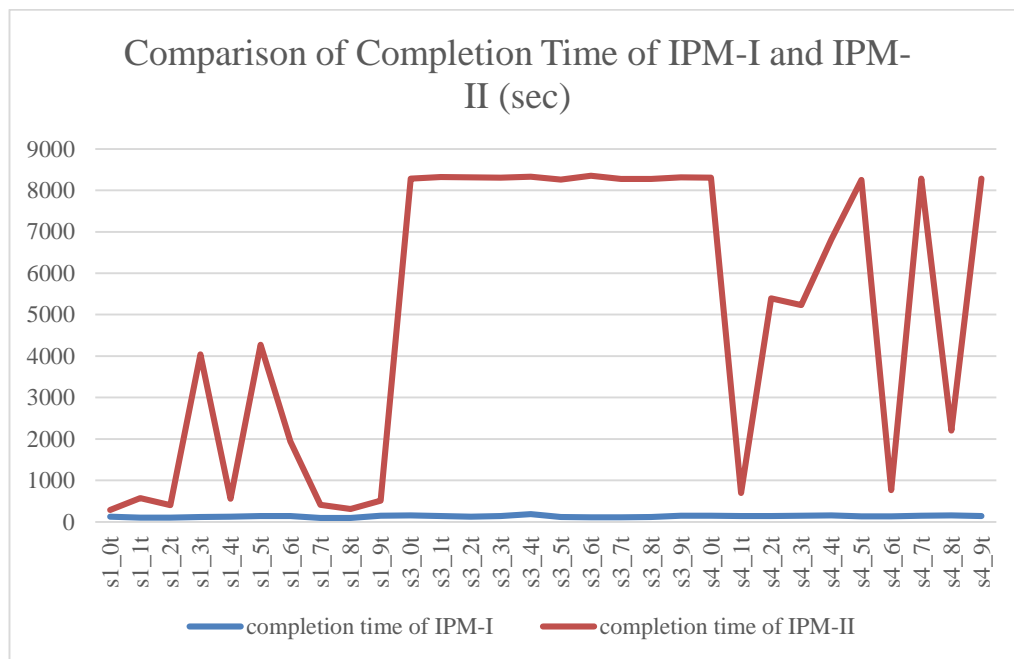

Figure 20 Comparison of completion time of IPM-II and IPM-I for 92 vehicles, 3 demand and starting period 4

As it is illustrated in Figure 20, IPM-I reaches to solution faster than IPM-II. Thereby, other run sets are prepared for IPM-I.

Different from IPM-II, mode changing solution of IPM-I consists of less number of changes because of vehicle representation style. Mode changings are obtained from run set with 3 demands that occur from fourth period forward, 92 vehicles and zero period between two demands of IPM-I for scenario 1 (92IV3D0T4) is presented in Table 35.

Table 35 Solution of mode changing for 92IV3D0T4

Warehouse	Arrival mode	Departure mode	Period 3	Period 4	Intermodal cross-docking
Izmir	Highway	Railway	1		✓
Izmir	Airway	Railway	1		✓
Antalya	Railway	Railway		1	✗

Percentage of intermodal usage in 92IV3D0T4 is 66% that is less than the result of IPM-II. Mode changing can occur for each vehicle in IPM-II. However, in IPM-I, mode changing can occur once for each mode.

To obtain a feasible solution for scenarios 2 and 5, vehicle numbers of suppliers and warehouses increased to 412, 872 and 2032. Because of lead time, minimum period of starting demand is sixteenth to found a solution for scenario 2. On the other hand, for scenario 5, number of vehicles are increased since current number of vehicles can not satisfy amount of first demand. If number of vehicle is increased to 412 and demand starts at period 16, we can obtain optimal solution for scenario 2. To show flow vehicle used in scenario 2 for 412 vehicles, 3 demands, availabilities of vehicles at suppliers are illustrated in Table 36.

Table 36 Availabilities of transportation mode for 412 vehicles and demand starts at period 16 with 3 demands

Modes	Supplier	Period																								
		1	2	3	4	5	6	7	8	9	10	11	12	13	14	15	16	17	18	19	20	21	22	23	24	
Higway	Hamburg	40																								
Higway	Barcelona	40	40	40	40	40	40	40	40	40	40	40	40	40	40	40	40	40	40	40	40	40	40	40	40	
Ralway	Hamburg	20	20	20	20	20	20	20	20	20	20	20	20	20	20	20	20	20	20	20	20	20	20	20	20	
Ralway	Barcelona	20	20	20	20	20	20	20	20	20	20	20	20	20	20	20	20	20	20	20	20	20	20	20	20	
Seaway	Hamburg	3	3	3	3	3	3	3	3	3	3	3	3	3	3	3	3	3	3	3	3	3	3	3	3	
Seaway	Barcelona	3	3	3	3	3	3	3	3	3	3	3	3	3	3	3	3	3	3	3	3	3	3	3	3	
Airway	Hamburg	20	20	0	0	0	0	0	0	0	0	0	20											20	20	20
Airway	Barcelona	20	20	20	20	20	19	19	19	19	19	19	19	19	19	19	19	19	19	19	20	20	20	20	20	
Helicopter	Hamburg	20	20	2	2	1	1	1	1	1	1	1	19	1	2	2								18	18	18
Helicopter	Barcelona	20	20	20	19	19	19	19	16	16	16	9	9	9	8	8	8	9	9	9	9	12	12	12	19	

In order to obtain a feasible solution for scenario 5, run sets for 412, 872 and 2032 are solved. Optimal solutions and completion time of scenario 5 run sets are presented in Table 37.

Table 37 Optimal solutions of scenario 5

# of vehicle	vehicle rep. Style	scerio no	# of demand	# of period between demands	start of demand	cost	completion time
412	integervehicle	s5	5	1t	t4	5348787	122.03
412	integervehicle	s5	5	2t	t4	5197320	156.35
412	integervehicle	s5	5	3t	t4	5197320	176.263
412	integervehicle	s5	5	4t	t4	5197320	183.91
412	integervehicle	s5	5	1t	t16	4762709	131.222
2032	integervehicle	s5	3	0t	t4	2103246	136.881
2032	integervehicle	s5	3	1t	t4	2103246	132.791
2032	integervehicle	s5	3	2t	t4	2103246	104.328
2032	integervehicle	s5	3	3t	t4	2103246	105.908
2032	integervehicle	s5	3	4t	t4	2103246	140.281
2032	integervehicle	s5	3	5t	t4	2094963	154.57
2032	integervehicle	s5	3	6t	t4	2092906	148.309
2032	integervehicle	s5	3	7t	t4	2087101	144.629
2032	integervehicle	s5	3	8t	t4	2094588	144.579
2032	integervehicle	s5	3	9t	t4	2094431	145.945
872	integervehicle	s5	3	1t	t4	2075779	117.574
872	integervehicle	s5	3	2t	t4	2075779	114.66
872	integervehicle	s5	3	3t	t4	2075779	112.225
872	integervehicle	s5	3	4t	t4	2075779	145.434
872	integervehicle	s5	3	5t	t4	2040041	139.167
872	integervehicle	s5	3	6t	t4	2044106	110.489
872	integervehicle	s5	3	7t	t4	2040041	102.731
872	integervehicle	s5	3	8t	t4	2040041	107.101
872	integervehicle	s5	3	9t	t4	2044106	150.534

As is seen in Table 37, costs are higher than costs of other scenarios because of high usage of vehicle sources. Additionally, for 5 equal demands run sets of all scenarios are tested to observe performance of IPM-I at large scale instances. As a result of 5 demands running, IPM-I is more effective than IPM-II.

In order to highlight the effect of mode change, IPM-I is modified by adding constraints that does not allow multi-mode. This modified model is called as single mode modified IPM-I. Run sets for single mode modified IPM-I are tested, and solutions of single mode modified IPM-I are compared with IPM-I in next section according to performance measures. Difference between two models is to change mode between two same or different transportation means. Single mode IPM-I changes mode between two same transportation means. This is the main discussion of this thesis to show that intermodal transportation is more effective method for humanitarian logistics than single mode transportation. Mode changing solutions of single mode modified IPM-I for scenario 1 with 92 vehicles, 3 demands that occur from fourth period forward and zero period between two demands (92SMV3D0T4) are shown in Table 38.

Table 38 Solutions of mode changing for 92SMV3D0T4

Warehouse	Arrival mode	Departure mode	Period 3	Period 4	Intermodal cross-docking
Izmir	Highway	Highway	1		×
Antalya	Railway	Railway		1	×
Antalya	Helicopter	Helicopter	1		×

According to Table 38, percentage of intermodal usage is 0% for 92SMV3D0T4. Because of this situation, in some scenarios, feasible solution cannot be obtained from single mode run sets. Infeasible instances for single mode modified IPM-I are presented in Table B.5 in Appendices B.

5.5.3 Comparisons

In this section, comparisons of results of instances for all scenarios are discussed. Comparison of instances are made with respect to the average values of each performance criterion that figures out the quality of transportation operations for commercial supply chains. On the other hand, to observe the effect of using intermodal transportation and utilizing multi-mode concept for relief item distribution in humanitarian logistics, IPM-I is modified to only allow single mode transportation for delivery of relief items. IPM-I and IPM-II have same solutions. Because of this, they are compared according to their execution times in result part of thesis. Therefore, solutions of single mode IPM-I are compared with IPM-I to show success of this thesis in this chapter. These models are compared according to performance measures for each scenario. In comparisons, scenarios where from obtained solution for both models, are used.

Firstly, IPM-I and modified IPM-I are compared in terms performance measures that obtained from scenario 1. Additionally, average period costs of instances of scenario 1 are compared according to IPM-I and single model IPM-I as it seen in Figure 21.

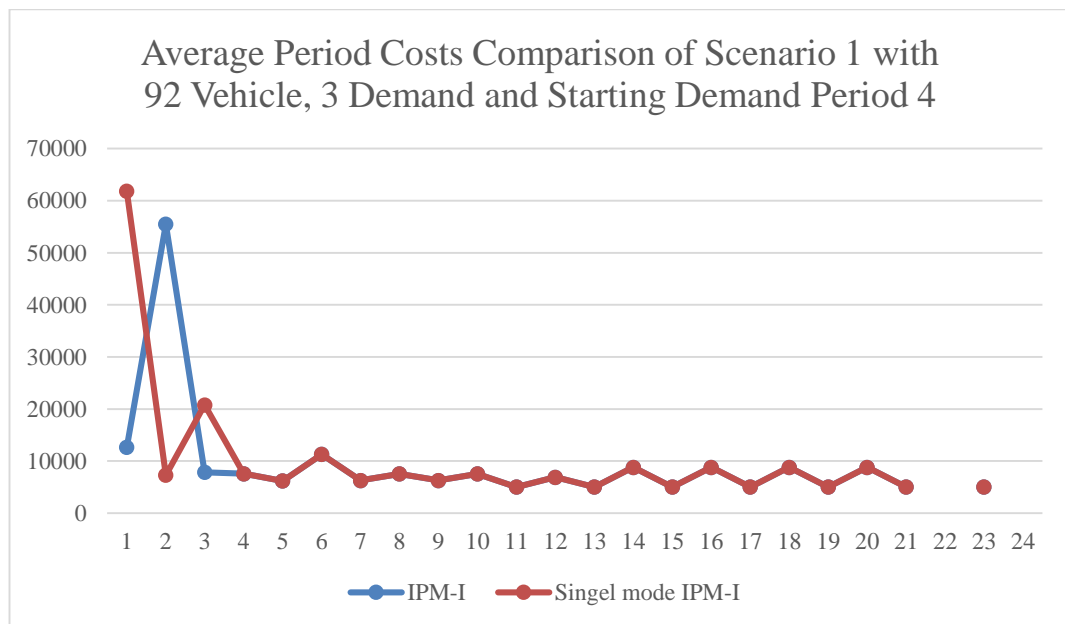

Figure 21 Average period costs comparison of scenario1.

In Figure 22, average period costs of the two models differentiates at first four periods because of first demand occurrence. In these instances, demand starts at period four, therefore, two models use all transportation sources to satisfy first demand. Since IPM-I can use varied transportation means, it can assign less priced and faster transportation means than single mode IPM-I. After satisfying the first demand, both models can hold inventory and use same transportation means that are less priced. As a result of this, IPM-I is more cost effective than single mode IPM-I according to period costs.

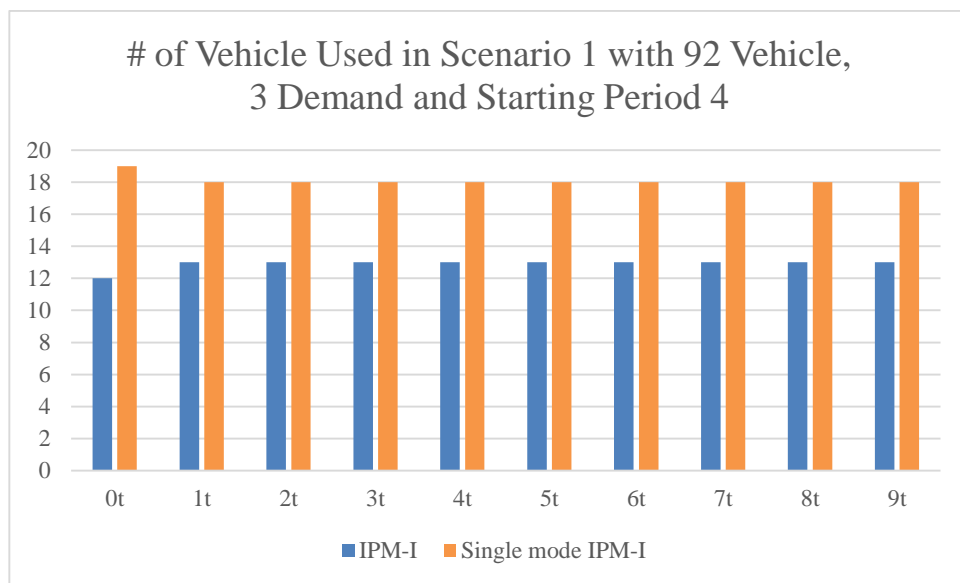

Figure 22 Number of vehicles used in scenario 1

After discussion of period costs, number of vehicles used of instances of scenario 1 is compared according to two models. As it seen in Figure 22, Single mode IPM-I is used more vehicle than IPM-I in each instances that differentiated from periods between demands. Thereby, single mode IPM-I has higher costs than IPM-I for each period. According to this comparison, IPM-I uses transportation sources more effectively and at low cost. Additionally, if transportation source level decreased at suppliers and warehouses, single mode IPM-I cannot reach a solution.

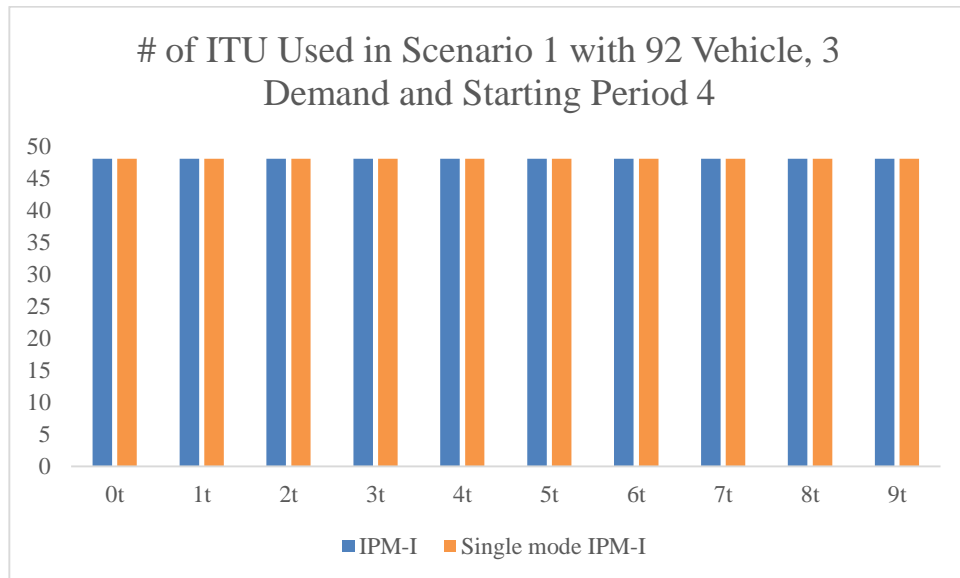

Figure 23 Number of ITU of scenario 1.

Number of ITU used are dependent on amounts of demands for both models. Thereby, both model transport relief items by using same number of ITUs in each instance of scenario 1. As it is presented in Figure 23, IPM-I and single mode IPM-I use same number of ITUs.

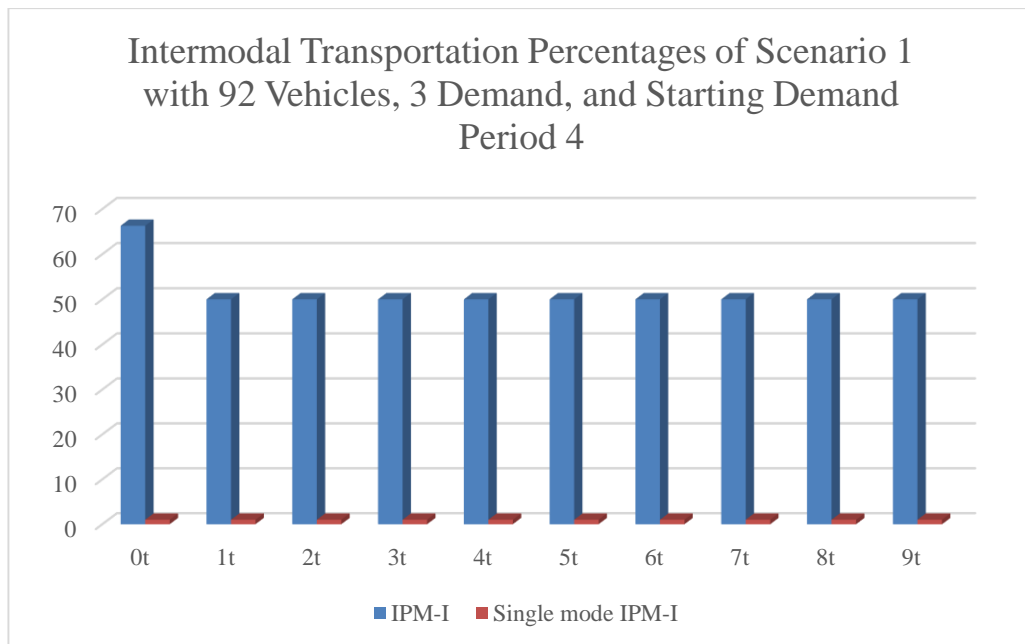

Figure 24 Intermodal transportation percentages of scenario 1.

Intermodal percentage that is the most important performance measure of this thesis, is compared with two models to observe which model is more resilient when routes are not available for transportation means. In Figure 24, intermodal percentage of the two models are compared according to number of periods between demands. Single mode IPM-I has zero percent of intermodal usage since mode change is banned. IPM-I is the most resilient model due to the higher mode changing ability.

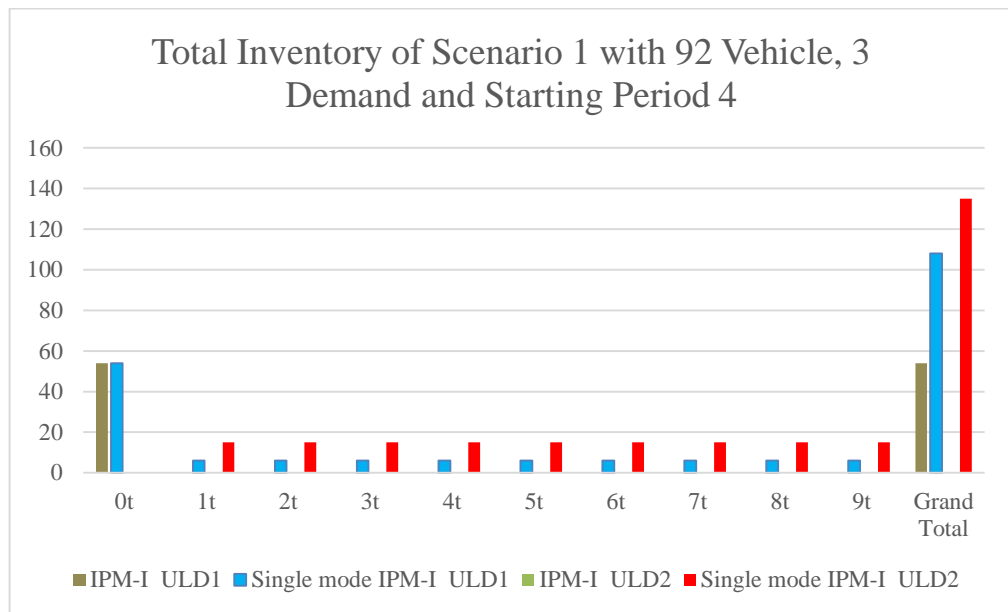

Figure 25 Total number of ULDs stored according to the two models and number of demand occurrence

Total inventory of ULD level refers to ability of transporting relief items on time. If a model stores more inventory, this model has no enough vehicles at warehouses or cannot cross-dock available transportation means at warehouses. In this study, low inventory levels are desired. On the other hand, higher inventory of ULDs provides resilient transportation for the warehouses. According to lead times of vehicles, suppliers may not transport relief items to warehouses. At this point, warehouses can use inventory to transport relief items to disaster areas. Comparison of the two models according to total inventory levels of ULDs is illustrated in Figure 25. As a result of this comparison, in terms of cost and resilience, IPM-I are the most effective model. Whereas, single mode is more effective for resilience lifeline of delivery relief items.

Another important performance measure is the fill rates of vehicles. Fill rate refers to performance of transportation on effective loading of the vehicles. In this thesis, high percent fill rates are preferred. Resulted average fill rates of the two models are compared for different number of periods between demands and shown in Figure 26. Single mode transportation does not allow less capacitated vehicles for the delivery of relief items. Therefore, in this comparison, most effective transportation belongs to single mode IPM-I.

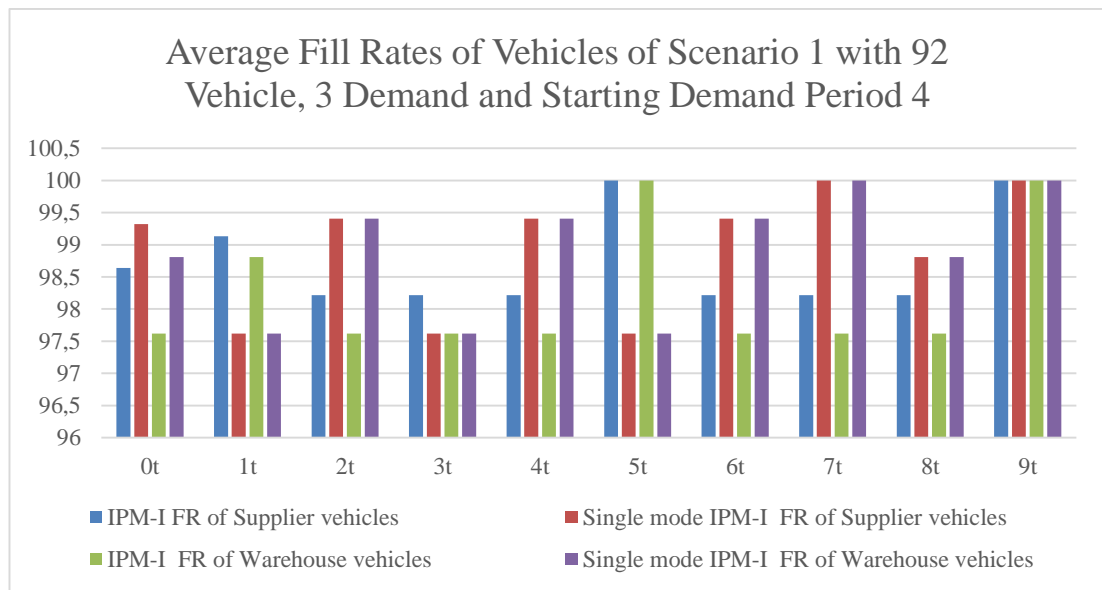

Figure 26 Average fill rates of vehicles according to two models and number of demand occurrence

As a result of these comparisons of average values of performance measures, the most effective transportation model is seen IPM-I in the overall.

Another tool for evaluating performance of models is comparison of cost element. Objective of three models is to minimize the total transportation and inventory holding cost. To be able to see which model is the most cost effective for the delivery of relief items, three models are compared in terms of average total cost, number of demands and starting demand period. Comparison of IPM-I and single mode IPM-I for 3 demands that occur from 4th period forward according to objective function values is presented in Figure 27. As it is seen in the figure, IPM-I is dominating the single mode IPM-I in terms of total cost for each instances of scenario 1.

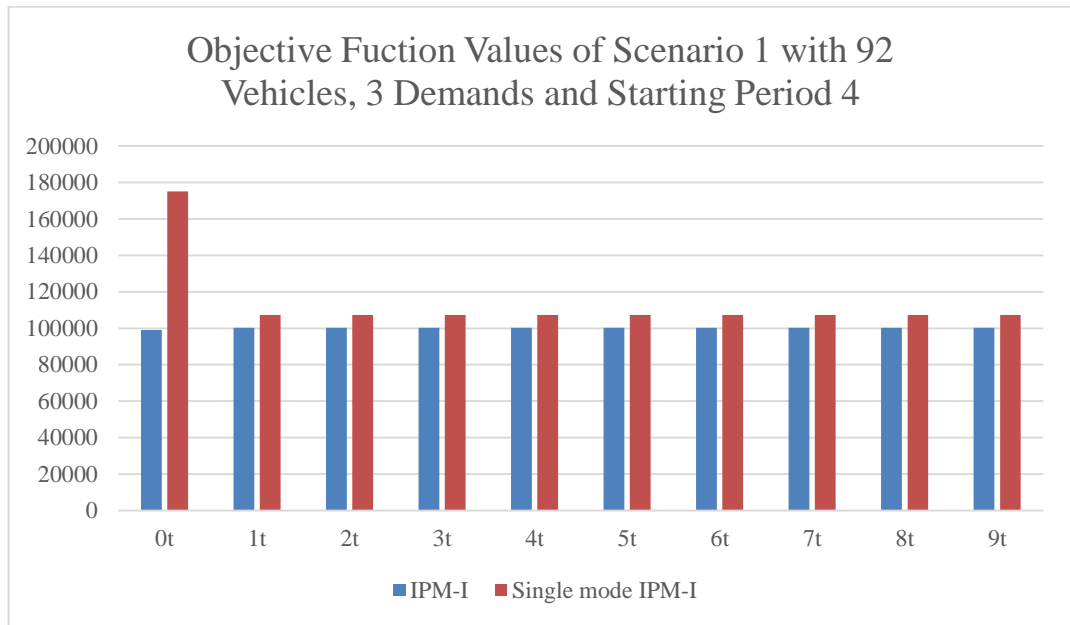

Figure 27 Objective function cost of IPM-I and Single mode with three demand occurrences that star at first period is 4

After comparison related to cost, completion times of two models are compared according to instances of scenario 1. For humanitarian logistics, response time is very important performance measure. Comparison for two models according to execution times is illustrated in Figure 28. According to Figure 28, the slowest model is single mode IPM-1, since banned intermodal transportation in dynamic network flow problem causes more complexity than model with intermodal IPM. As a result of this comparison, IPM-I is more effective model than single mode IPM-I for humanitarian logistics.

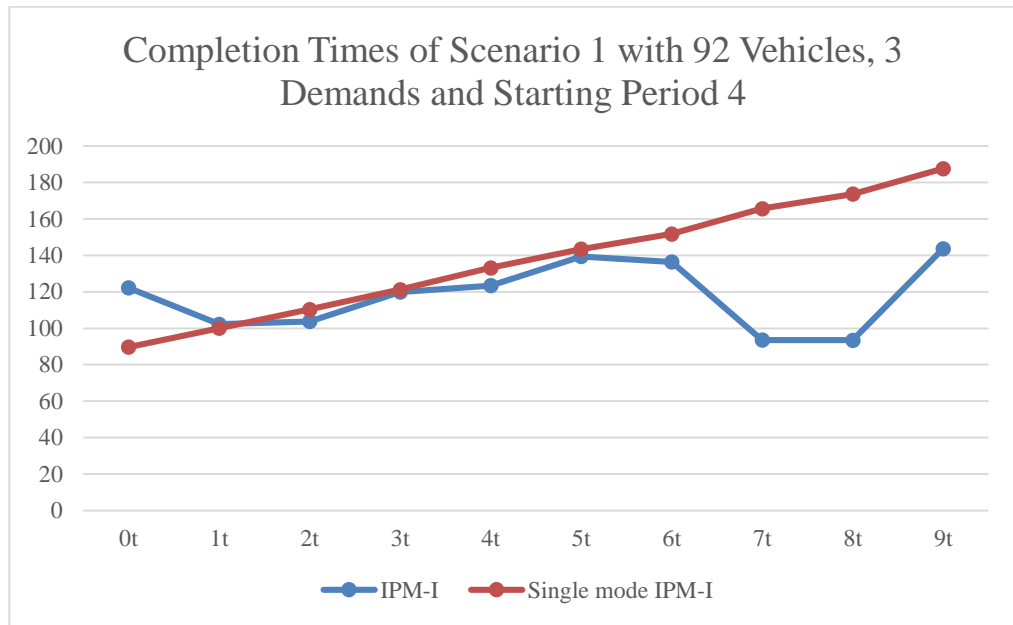

Figure 28 Completion time of IPM-I and Single mode IPM-I

As a result of these comparison, IPM-I is more resilient model according to performance measures for instances of scenario 1. Same comparisons are discussed for rest of scenarios.

In scenario 2, run sets with 412 vehicles and starting demand period sixteen give solutions. Thereby, performance measures are compared for these run sets according to IPM-I and single mode IPM-I. Firstly, average period costs are compared according to the two models as it seen in Figure 29. In the Figure, none of the models are dominating the each other in terms of average period cost. Similar with scenario 1, in this comparison, models transported relief items to meet demand of sixteenth period firstly. Therefore, in first sixteen periods, IPM-I and single mode IPM-I use high priced transportation means, since shortest path must be selected to delivery of relief item on time.

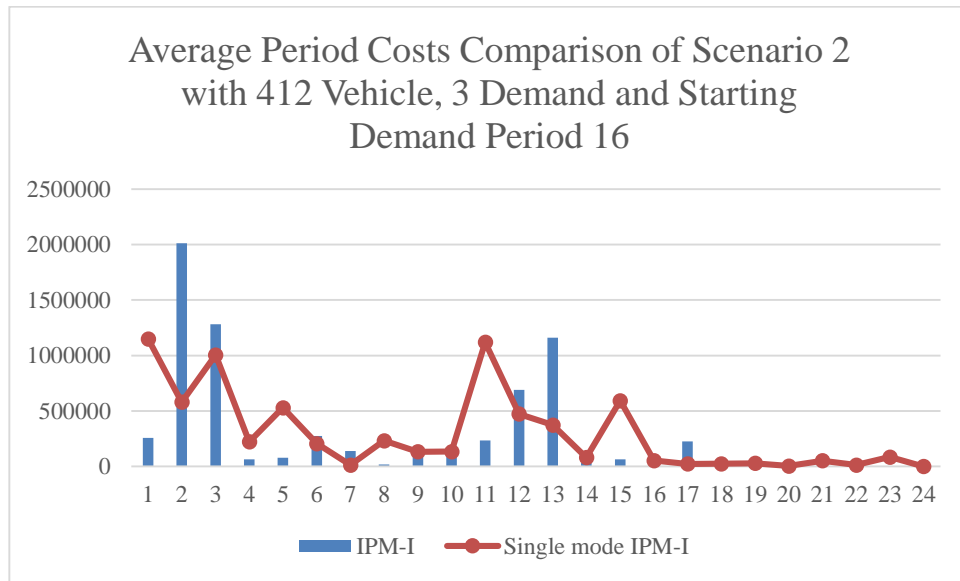

Figure 29 Average period costs of IPM-I and Single mode IPM-I

Secondly, number of vehicle used is compared according to instances of scenario 1 as it seen in Figure 30. According to this comparison, IPM-I used more vehicle in instance with two periods between demands for scenario 2. Rest of instances, single mode IPM-I used more vehicles than IPM-I. It shows that IPM-I dominates single mode IPM-I in terms of cost of vehicle usage.

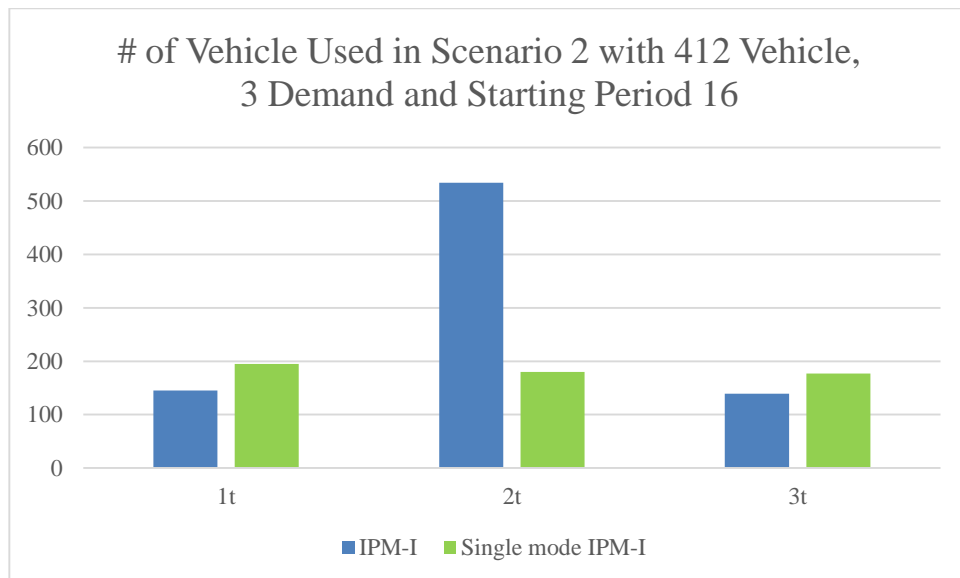

Figure 30 Number of vehicle used of IPM-I and Single mode IPM-I.

After discussion of number of vehicle used, number of ITU used is compared according to two models for scenario 2. According to this comparison, single mode IPM-I used more ITU than IPM-I since model used more vehicles than IPM-I as shown in Figure 31.

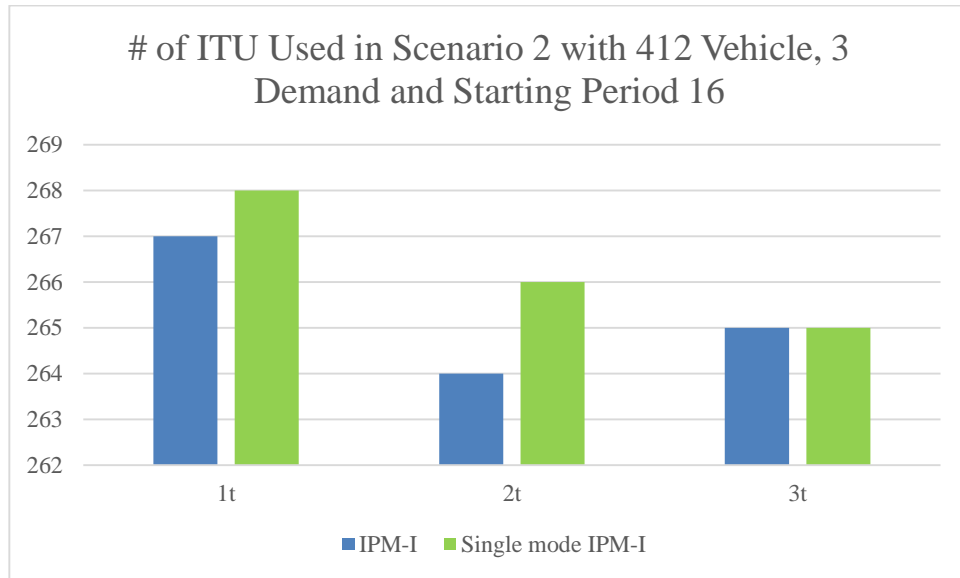

Figure 31 Number of ITU used of IPM-I and Single mode IPM-I.

In the light of this information, if fill rates are compared for instances of scenario 1, number of vehicle and ITU used and fill rates of vehicles are changed according to two models relatively. In Figure 32, average fill rates of vehicles in scenario 2 are compared according to IPM-I and single mode IPM-I. Thereby, single mode IPM-I used more vehicle and ITU with high fill rates than IPM-I.

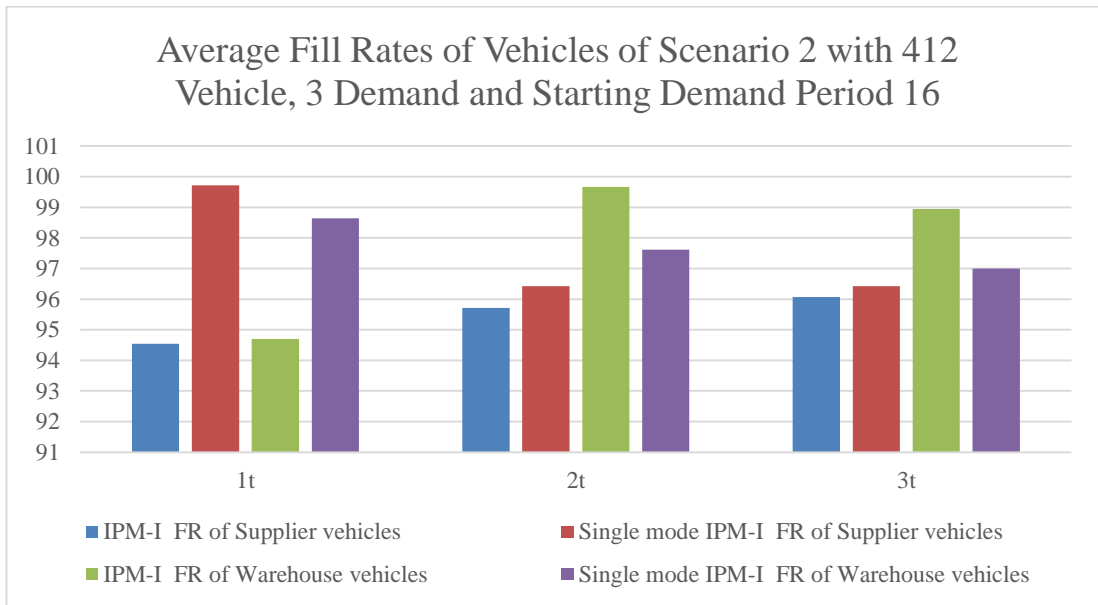

Figure 32 Average fill rates of IPM-I and Single mode IPM-I.

Another performance measure comparison is for total inventory of ULDs. This comparison represents, which model use warehouses and transportation means more. As it seen in Figure 33, none of the models is dominating each other in terms of number of ULDs stored. But, in according to grand total of inventory, single mode IPM-I used warehouses more. On the other hand, IPM-I used varied transportation means with less holding cost.

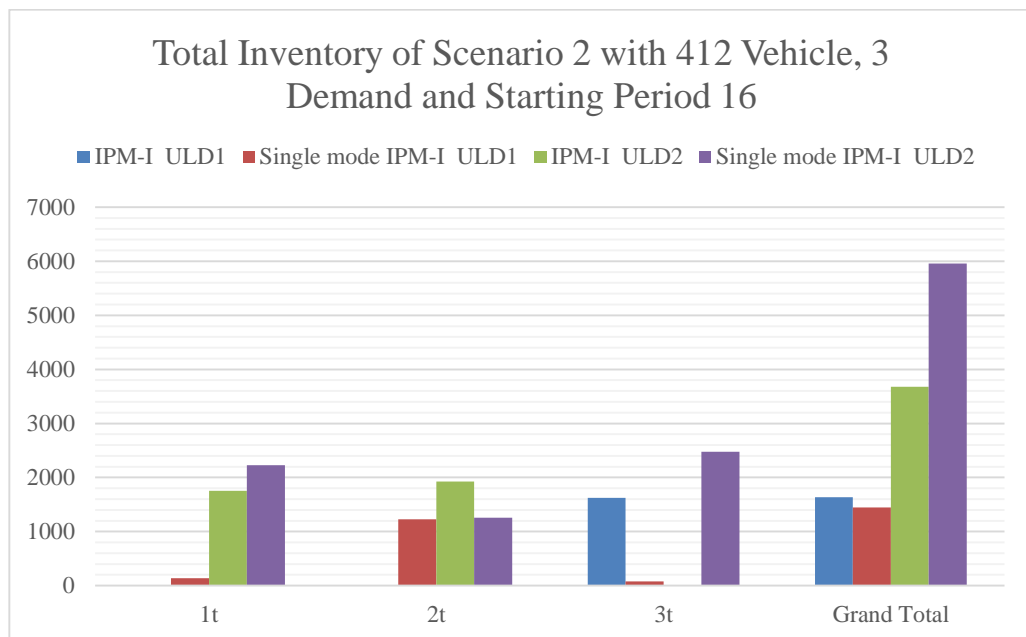

Figure 33 Total number of ULDs stored according to the two models and number of demand occurrence.

Because of constraints of single mode IPM-I that do not allowed to cross-dock between two different transportation means, intermodal transportation percentages are always zero in single mode IPM-I as shown in Figure 34.

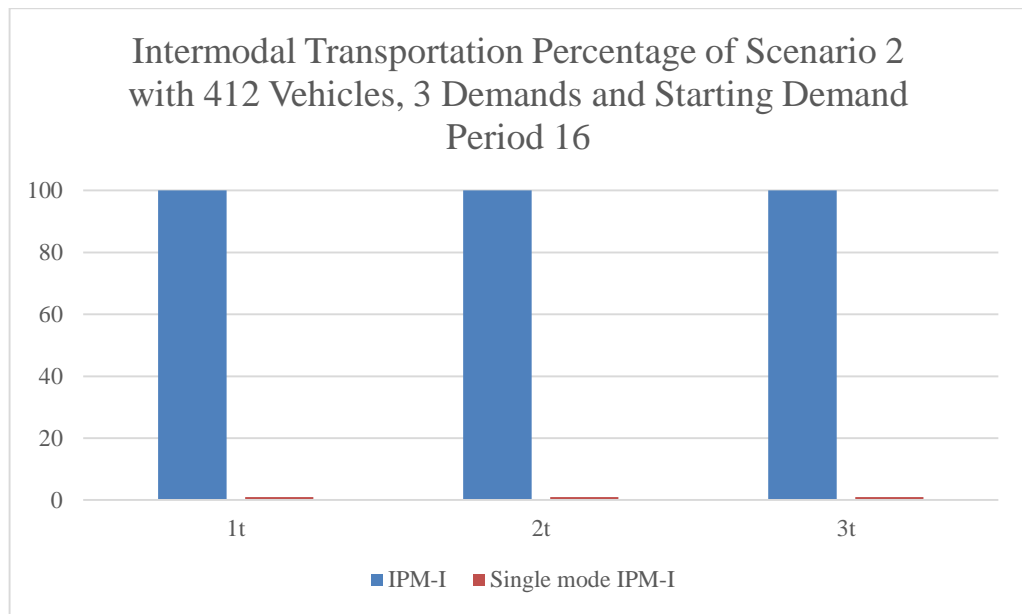

Figure 34 Intermodal transportation percentages according to the models.

After comparison related to intermodal transportation percentage, objective function values of two models are compared according to instances of scenario 2 as shown in Figure 35. According to Figure 35, IPM-I is more cost effective transportation methods than single mode IPM-I for scenario 2.

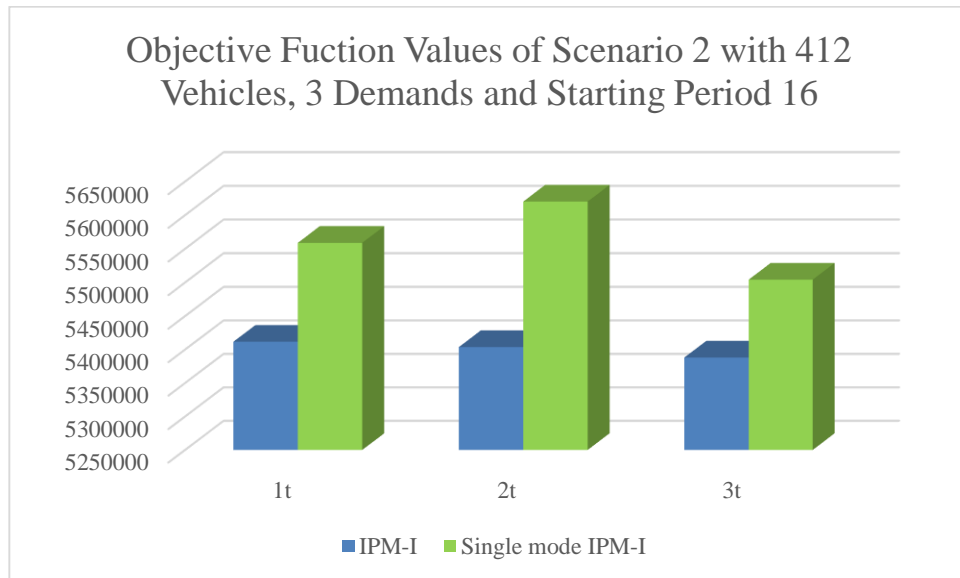

Figure 35 Intermodal transportation percentages according to the models.

Another important comparison criterion is completion time that is important for humanitarian logistics. As it seen in Figure 36, IPM-I is the most effective method than single mode IPM-I.

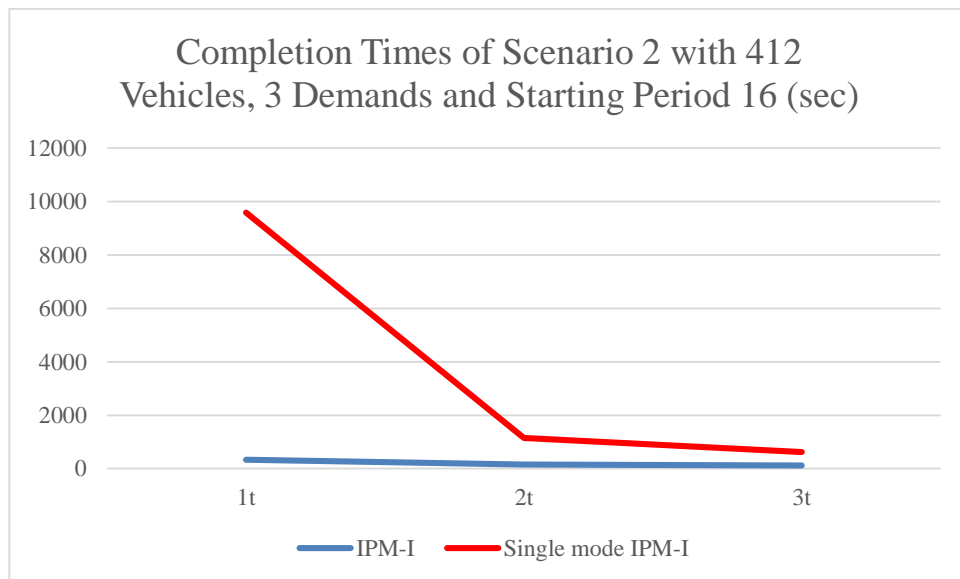

Figure 36 Completion time of scenario 2 according to the models.

Scenario 3 is also compared according to performance measures and some important comparison criteria. In this comparison, we observed that, both models reached same solution excluding completion time. Rest of comparisons for all instances is presented

according to type of two models in Figure A.3, Figure A.4, Figure A.5, Figure A.6 and Figure A.7 in Appendices A.

In scenario 3, IPM-I behave in a single mode IPM-I. Therefore, both model used same transportation means for delivery of relief items and their intermodal transportation percentages are zero for each instances of scenario 3 as it seen in Figure 37.

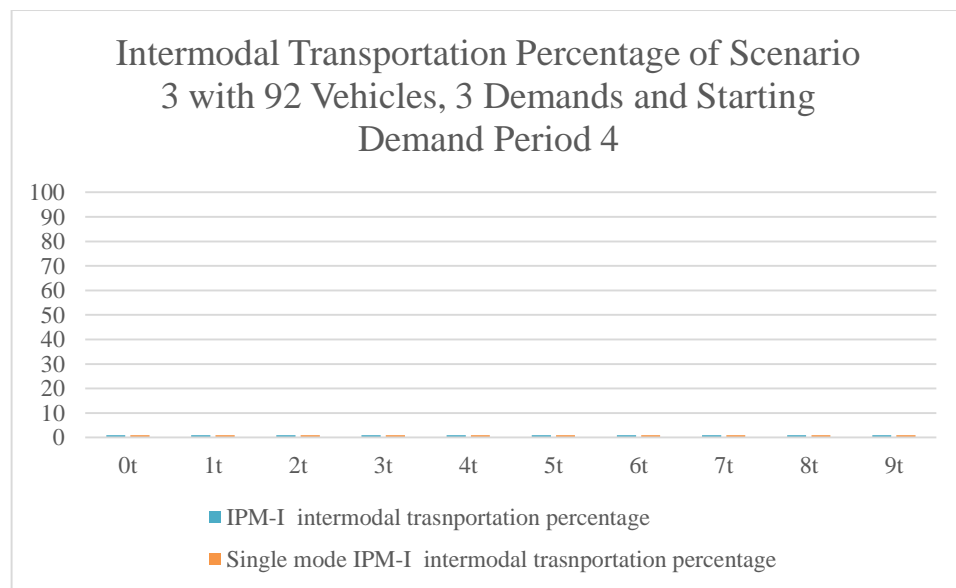

Figure 37 Intermodal transportation percentages of instances scenario 3.

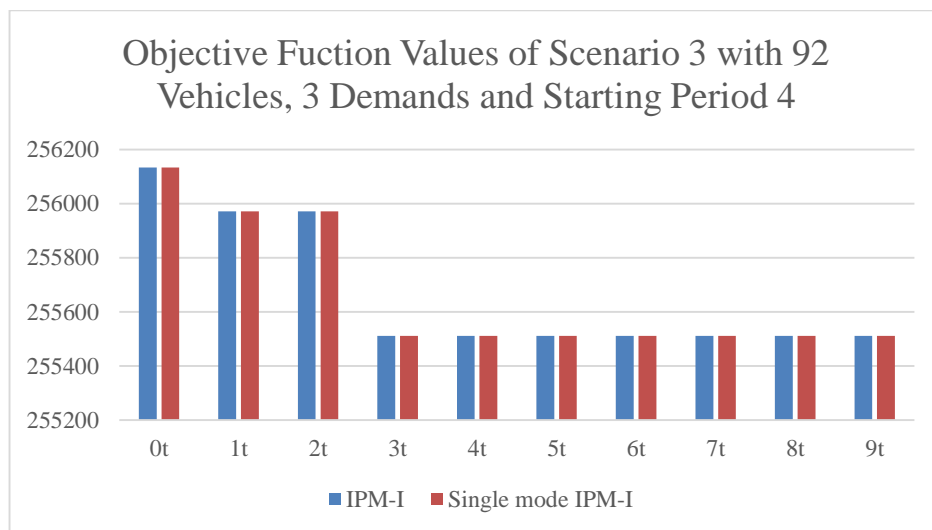

Figure 38 Objective function value of IPM-I and single mode IPM-II in scenario 3.

Objective function values are same both models as it seen in Figure 43. Objective function changes are also effected by starting demand period. Starting demand period is four. Therefore, models try to satisfy demands until first occurrence.

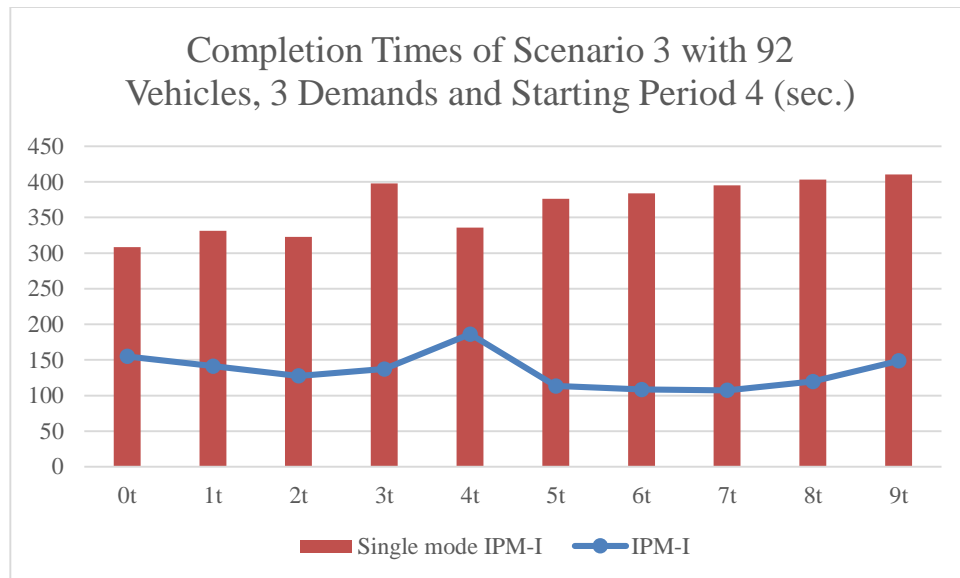

Figure 39 Completion times of IPM-I and single mode IPM-II in scenario 3.

According to completion time, IPM –I is also faster than IPM-II. It shows that IPM-I is more resilient transportation relief items.

In scenario 4, all comparisons are same for both models. Also in this scenario, intermodal transportation is not used. Both model behave single mode IPM-I. Rest of comparisons for all instances is presented according to type of two models in Figure A.8, Figure A.9, Figure A.10, Figure A.11, Figure A.12, Figure A.13, Figure A.14 and Figure A.15 in Appendices A.

In scenario 5, we obtained solutions from only IPM-I. Single mode IPM-I did not give a solution since intermodal transportation is not allowed. In order to obtain solution of scenario 5, number of vehicles is increased. Thus, model have to use all transportation sources to delivery of relief items. Thereby, single mode IPM-I can not be used for this scenario. This experiment shows that intermodal transportation is more resilience than single mode transportation. Comparison of objective functions of the two models is presented in Table for 412 vehicles with 5 distinct periods demand. Additionally, to

observe effect of more vehicle sources on the two models, run sets with 2032 vehicles and 3 distinct periods demand are solved. Also, solutions of the two models for this experiment is presented in Table 39.

Table 39 Results comparison of scenario 5 with 412 vehicle

5 Demand				
# of vehicle = 412 # of Distincts Demands = 5 # of Periods bw Demands	Objective Function Value			
	Starting Period = 16		Starting Period = 4	
	IPM-I	Single mode IPM-I	IPM-I	Single mode IPM-I
1t	4762708.81	No solution	5348787.2	No solution
2t	No Experiment	No Experiment	5197320.3	No solution
3t	No Experiment	No Experiment	5197320.3	No solution
4t	No Experiment	No Experiment	5197320.3	No solution

According to Table 40, IPM-I reached optimal solution for each instance in scenario 5.

Table 40 Results comparison of scenario 5 with 412 vehicle

# of vehicle = 2032 # of Distincts Demands = 3 Starting Period = 4		
# of Periods bw Demands	IPM-I	Single mode IPM-I
0t	2103246.2	No solution
1t	2103246.2	No solution
2t	2103246.2	No solution
3t	2103246.2	No solution
4t	2103246.2	No solution
5t	2094963.1	No solution
6t	2092905.9	No solution
7t	2087101.4	No solution
8t	2094587.6	No solution
9t	2094430.8	No solution
Grand Total	20980219.89	No solution

Since single mode IPM-I has not solution for the scenario 5, performance measures of IPM-I are analysed and compared each other. Performance measures of IPM-I for scenario 5 are presented in Figure A.16, Figure A.17, Figure A.18, Figure A.19 and Figure A.16 in Appendix A.

CHAPTER 6

CONCLUSION

This study considers intermodal freight transportation in humanitarian logistics that aims the transportation of relief items in case of a disaster. For this purpose, the literature is reviewed and similar studies that are focused on transportation of relief items are analyzed. On the other hand, intermodal freight transportation models and applicability of intermodal freight transportation in humanitarian logistics are examined. Since, the objective is related with human life instead of commercial concerns, and subject to more tight constraints; it is hard to adopt models in the literature. Due to the nature of intermodal transportation, a unit loading device is defined to avoid material handling of relief items separately. Afterwards, two integer programming models are developed based on a time-space network by considering route and vehicle availabilities changing dynamically over a specified time horizon. However, in the second model each vehicle is represented by a binary variable. Hence, with the increase in the size of the problem, the model becomes intractable in terms of the run time complexity. Albeit the large sized problem instances are hard to solve optimally, a second formulation is developed to tackle this situation with integer representation of vehicles. Number of vehicles available in each period is tracked with integer variable by considering lead time of the vehicle. By this way, the number of decision variables are significantly decreased.

After developing these mathematical models, they are tested under five different scenarios. Number of periods between two demands, number of vehicles, and first occurrence period of a demand differentiate these scenarios.

To be able to see the effect of including intermodal transportation and utilizing multi-mode concept for relief item distribution in humanitarian logistics, the proposed model

IPM-I is modified to restrict the model for the use of only single mode transportation for relief distribution.

Number of vehicles used, fill rate of vehicles, number of intermodal transportation units (ITU) used, inventory holding and percentage of intermodal transportation usage in delivery of relief items are determined as performance measures and analysis of run results are presented according to these criteria. IPM-I provides better results in terms of specified performance measures.

In order to test capacities of models that are proposed in this thesis, large scale problem can be constructed. In this study five network nodes were used, but in future research, this number can be increased to hundreds. After determination of limits of models, heuristic algorithm can be derived. In addition to large scale problem, experimental studies can be enhanced according to time periods, number of suppliers, warehouses, disaster areas, type of ITUs, type of ULDs and type of relief items. With all that objective of the models can be changed from cost to response time, unmet demand, road reliability etc. A decision support system can be designed and constructed together with improvements of models.

In the response phase of humanitarian logistics, the transportation of relief items plays a vital role in the survival of people. Hence, an efficient transportation plan should be developed in a very short time. This study helps to create a resilient transportation plan that considers mode changes with vehicle and route availabilities. To the best of our knowledge, the proposed models in this study brought a new perspective by combining intermodal freight transportation and humanitarian logistics.

REFERENCES

1. International Federation of Red Cross and Red Crescent Societies, (2016), “*What is a Disaster?*”, <https://www.ifrc.org/en/what-we-do/disaster-management/about-disasters/what-is-a-disaster/>, (Data Download Date: 05.01.2016).
2. Emergency Events Database, (2016), “*The EM-DAT Glossary*”, <http://www.emdat.be/glossary/9>, (Data Download Date: 05.01.2016).
3. Özkapıcı B. D., (2015), An Intermodal Humanitarian Logistics Model Based On Maritime Transportation for Relief Item Distribution in Istanbul, M.S. Thesis, Dept. of Ind. Eng., Çankaya Univ., Turkey.
4. Kopczak, L. R., & Thomas, A. S. (2005). From Logistics to Supply Chain Management: The Path Forward in the Humanitarian Sector. *Fritz Institute, California*.
5. Torabi, S. A., Baghersad, M., & Mansouri, S. A. (2015). Resilient supplier selection and order allocation under operational and disruption risks. *Transportation Research Part E: Logistics and Transportation Review*, 79, 22-48.
6. Ponomarov, S. Y., & Holcomb, M. C. (2009). Understanding the concept of supply chain resilience. *The International Journal of Logistics Management*, 20(1), 124-143.

7. Falasca, M., Zobel, C. W., & Cook, D. (2008, May). A decision support framework to assess supply chain resilience. In *Proceedings of the 5th International ISCRAM Conference* (pp. 596-605).
8. Chen, L., & Miller-Hooks, E. (2012). Resilience: an indicator of recovery capability in intermodal freight transport. *Transportation Science*, 46(1), 109-123.
9. Ip, W. H., & Wang, D. (2009, April). Resilience evaluation approach of transportation networks. In *Computational Sciences and Optimization, 2009. CSO 2009. International Joint Conference on* (Vol. 2, pp. 618-622). IEEE.
10. Zhang, L., Wen, Y., & Jin, M. (2009). *The framework for calculating the measure of resilience for intermodal transportation systems* (No. NCIT Report# 10-05-09).
11. Adams, T. M., Bekkem, K. R., & Toledo-Durán, E. J. (2012). Freight resilience measures. *Journal of Transportation Engineering*, 138(11), 1403-1409.
12. Wang, D., & Ip, W. H. (2009). Evaluation and analysis of logistic network resilience with application to aircraft servicing. *Systems Journal, IEEE*, 3(2), 166-173.
13. Emergency Events Database, (2016), “*Result for Country Profile*”, <http://www.emdat.be/result-country-profile> ,
(Data Download Date: 05.01.2016).

14. Özmen, B. (17). Ağustos 1999 İzmit Körfezi Depreminin Hasar Durumu (Rakamsal Verilerle). *Türkiye Deprem Vakfı*, 132.
15. Parsons, T., Toda, S., Stein, R. S., Barka, A., & Dieterich, J. H. (2000). Heightened odds of large earthquakes near Istanbul: An interaction-based probability calculation. *Science*, 288(5466), 661-665.
16. Özdamar, L., Ekinçi, E., & Küçükyazıcı, B. (2004). Emergency logistics planning in natural disasters. *Annals of operations research*, 129(1-4), 217-245.
17. Görmez, N., Köksalan, M., & Salman, F. S. (2011). Locating disaster response facilities in Istanbul. *Journal of the Operational Research Society*, 62(7), 1239-1252.
18. Salman, F. S., & Gül, S. (2014). Deployment of field hospitals in mass casualty incidents. *Computers & Industrial Engineering*, 74, 37-51.
19. IMM, I. M. M. (2002). The study on a disaster prevention/mitigation basic plan in Istanbul including seismic microzonation in the republic of Turkey.
20. The United Nations Economic and Social Commission for Asia and the Pacific, (2016), “*Manual on Modernization of Inland Water Transport for Integration within a Multimodal Transport System Chapter 1*”, <http://www.unescap.org/resources/manual-modernization-inland-water-transport-integration-within-multimodal-transport-system> , (Data Download Date: 05.01.2016).
21. UNECE (2009). Illustrated glossary for transport statistics. ISBN: 978-92-79-17082-9.

- <http://ec.europa.eu/eurostat/documents/3859598/5911341/KS-RA-10-028-EN.PDF/6ddd731e-0936-455a-be6b-eac624a83db4> ,
(Data Download Date: 05.01.2016).
22. The International Air Transport Association (IATA), (2016), “Unit Load Devices (ULD)”,
<https://www.iata.org/whatwedo/cargo/unit-load-devices/pages/index.aspx> ,
(Data Download Date: 05.01.2016).
23. Van Wassenhove, L. N. (2006). Humanitarian aid logistics: supply chain management in high gear†. *Journal of the Operational Research Society*, 57(5), 475-489.
24. Duran, S., Ergun, Ö., Keskinocak, P., & Swann, J. L. (2013). Humanitarian logistics: advanced purchasing and pre-positioning of relief items. In *Handbook of Global Logistics* (pp. 447-462). Springer New York.
25. International Federation of Red Cross and Red Crescent Societies, (2016), “About Disaster Management”,
<http://www.ifrc.org/en/what-we-do/disaster-management/about-disaster-management/> ,
(Data Download Date: 05.01.2016).
26. Altay, N., & Green, W. G. (2006). OR/MS research in disaster operations management. *European journal of operational research*, 175(1), 475-493.
27. International Federation of Red Cross and Red Crescent Societies, (2016), “Preparing for disasters”,
<http://www.ifrc.org/en/what-we-do/disaster-management/preparing-for-disaster/> ,
(Data Download Date: 05.01.2016).

28. International Federation of Red Cross and Red Crescent Societies, (2016),
“From crisis to recovery”,
<http://www.ifrc.org/en/what-we-do/disaster-management/from-crisis-to-recovery/> ,
(Data Download Date: 05.01.2016).
29. Baird, M. E. (2010). The “phases” of emergency management. *Background paper. Prepared for the Intermodal Freight Transportation Institute (ITFI) University of Memphis. Nashville: Vanderbilt Center for Transportation Research (VECTOR)*.
30. Luis, E., Dolinskaya, I. S., & Smilowitz, K. R. (2012). Disaster relief routing: Integrating research and practice. *Socio-economic planning sciences*, 46(1), 88-97.
31. Natarajathinam, M., Capar, I., & Narayanan, A. (2009). Managing supply chains in times of crisis: a review of literature and insights. *International Journal of Physical Distribution & Logistics Management*, 39(7), 535-573.
32. Apte, A. (2010). *Humanitarian logistics: A new field of research and action* (Vol. 7). Now Publishers Inc.
33. Caunhye, A. M., Nie, X., & Pokharel, S. (2012). Optimization models in emergency logistics: A literature review. *Socio-economic planning sciences*, 46(1), 4-13.
34. Thomas, A., & Mizushima, M. (2005). Logistics training: necessity or luxury. *Forced Migration Review*, 22(22), 60-61.

35. Natarajathinam, M., Capar, I., & Narayanan, A. (2009). Managing supply chains in times of crisis: a review of literature and insights. *International Journal of Physical Distribution & Logistics Management*, 39(7), 535-573.
36. Haghani, A., & Oh, S. C. (1996). Formulation and solution of a multi-commodity, multi-modal network flow model for disaster relief operations. *Transportation Research Part A: Policy and Practice*, 30(3), 231-250.
37. Özdamar, L., & Ertem, M. A. (2015). Models, solutions and enabling technologies in humanitarian logistics. *European Journal of Operational Research*, 244(1), 55-65.
38. Afshar, A., & Haghani, A. (2012). Modeling integrated supply chain logistics in real-time large-scale disaster relief operations. *Socio-Economic Planning Sciences*, 46(4), 327-338.
39. Yi, W., & Özdamar, L. (2007). A dynamic logistics coordination model for evacuation and support in disaster response activities. *European Journal of Operational Research*, 179(3), 1177-1193.
40. Yi, W., & Kumar, A. (2007). Ant colony optimization for disaster relief operations. *Transportation Research Part E: Logistics and Transportation Review*, 43(6), 660-672.
41. Özdamar, L. (2011). Planning helicopter logistics in disaster relief. *OR spectrum*, 33(3), 655-672.

42. Özdamar, L., & Demir, O. (2012). A hierarchical clustering and routing procedure for large scale disaster relief logistics planning. *Transportation Research Part E: Logistics and Transportation Review*, 48(3), 591-602.
43. Balcik, B., Beamon, B. M., & Smilowitz, K. (2008). Last mile distribution in humanitarian relief. *Journal of Intelligent Transportation Systems*, 12(2), 51-63.
44. Lin, Y. H., Batta, R., Rogerson, P. A., Blatt, A., & Flanigan, M. (2011). A logistics model for emergency supply of critical items in the aftermath of a disaster. *Socio-Economic Planning Sciences*, 45(4), 132-145.
45. De Angelis, V., Mecoli, M., Nikoi, C., & Storchi, G. (2007). Multiperiod integrated routing and scheduling of World Food Programme cargo planes in Angola. *Computers & Operations Research*, 34(6), 1601-1615.
46. Vitoriano, B., Ortuño, M. T., Tirado, G., & Montero, J. (2011). A multi-criteria optimization model for humanitarian aid distribution. *Journal of Global Optimization*, 51(2), 189-208.
47. Vitoriano, B., Ortuno, T., & Tirado, G. (2009). HADS, a goal programming-based humanitarian aid distribution system. *Journal of Multi-Criteria Decision Analysis*, 16(1-2), 55-64.
48. Berkoune, D., Renaud, J., Rezik, M., & Ruiz, A. (2012). Transportation in disaster response operations. *Socio-Economic Planning Sciences*, 46(1), 23-32.

49. Barbarosoğlu, G., Özdamar, L., & Cevik, A. (2002). An interactive approach for hierarchical analysis of helicopter logistics in disaster relief operations. *European Journal of Operational Research*, 140(1), 118-133.
50. Hsueh, C. F., Chen, H. K., & Chou, H. W. (2008). *Dynamic vehicle routing for relief logistics in natural disasters*. INTECH Open Access Publisher.
51. Shen, Z., Dessouky, M. M., & Ordóñez, F. (2009). A two-stage vehicle routing model for large-scale bioterrorism emergencies. *Networks*, 54(4), 255-269.
52. Zhan, S. L., & Liu, N. (2011, April). A multi-objective stochastic programming model for emergency logistics based on goal programming. In *Computational Sciences and Optimization (CSO), 2011 Fourth International Joint Conference on* (pp. 640-644). IEEE.
53. Nolz, P. C., Semet, F., & Doerner, K. F. (2011). Risk approaches for delivering disaster relief supplies. *OR spectrum*, 33(3), 543-569.
54. Najafi, M., Eshghi, K., & Dullaert, W. (2013). A multi-objective robust optimization model for logistics planning in the earthquake response phase. *Transportation Research Part E: Logistics and Transportation Review*, 49(1), 217-249.
55. Barbarosoğlu, G. (2004). A two-stage stochastic programming framework for transportation planning in disaster response. *Journal of the operational research society*, 55(1), 43-53.

56. Tzeng, G. H., Cheng, H. J., & Huang, T. D. (2007). Multi-objective optimal planning for designing relief delivery systems. *Transportation Research Part E: Logistics and Transportation Review*, 43(6), 673-686.
57. Gu, Y. (2011). Research on optimization of relief supplies distribution aimed to minimize disaster losses. *Journal of Computers*, 6(3), 603-609.
58. Macharis, C., & Bontekoning, Y. M. (2004). Opportunities for OR in intermodal freight transport research: A review. *European Journal of operational research*, 153(2), 400-416.
59. Ertem, M. A. (2011, January). Forecasting Day of Week Volume Fluctuations in the Intermodal Freight Transportation. In *IIE Annual Conference. Proceedings* (p. 1). Institute of Industrial Engineers-Publisher.
60. Ishfaq, R., & Sox, C. R. (2011). Hub location–allocation in intermodal logistic networks. *European Journal of Operational Research*, 210(2), 213-230.
61. Woxenius, J. (1998). *Development of small-scale intermodal freight transportation in a systems context*. Chalmers University of Technology.
62. ULDCARE, (2016),
http://www.uldcare.com/DATA/DOCUMENT/V13_A12.pdf,
(Data Download Date: 05.01.2016).
63. The International Union for Road-Rail Combined Transport (UIRR), New markings of intermodal loading units in Europe,
<http://www.uirr.com/>,
(Data Download Date: 05.01.2016).

64. Çekerol, G. S. (2007). Lojistik Açından İntermodal Yük Taşımacılığı ve Türkiye Hızlı Tüketim Ürünleri Dağıtımını için Bir Uygulama. *Doktora Tezi, İşletme Anabilim Dalı, Dumlupınar Üniversitesi, Kütahya.*
65. Strawderman, L., & Eksioğlu, B. (2009). The Role of Intermodal Transportation in Humanitarian Supply Chains.
66. Şahin, A., Alp Ertem, M., & Emür, E. (2014). Using containers as storage facilities in humanitarian logistics. *Journal of Humanitarian Logistics and Supply Chain Management*, 4(2), 286-307.
67. Turkish Disaster and Emergency Management Presidency (2016),
https://www.afad.gov.tr/UserFiles/File/Haber_ic_Foto/lojistik_depolar.pdf ,
(Data Download Date: 05.01.2016).
68. Turkish State Railways (2016),
<http://www.tcdd.gov.tr/lojistik-merkezler+m129> ,
(Data Download Date: 05.01.2016).
69. Turkish Disaster and Emergency Management Presidency (2016),
<https://tabb-analiz.afad.gov.tr> ,
(Data Download Date: 05.01.2016).
70. Turkish Airlines (2016),
<http://www.turkishcargo.com.tr/tr/hizmet-agi-ve-filo/uld> ,
(Data Download Date: 05.01.2016).
71. <http://www.brinkley.cc/ULD/akh.htm>,
(Data Download Date: 05.01.2016).

72. Konteyner Gemileri için İstaktiksel Bilgiler,
<http://www.nasmaritime.com/kitap/kontgem-15112010-snas.pdf>,
(Data Download Date: 05.01.2016).
73. An interview with Şefik Can TEKİN, DHL Global Forwarding Taşımacılık A.Ş., Satış Bölge Müdürü, 05306421387
74. Turkish State Railways (2016),
[https://portal1.tcdd.gov.tr/tcdd\(bD10ciZjPTEwMCZkPW1pbg==\)/zy02/yuk_tasima_fiyatlari?menuId=https://portal1.tcdd.gov.tr/tcdd\(bD10ciZjPTEwMCZkPW1pbg==\)/zy02/yuk_tasima_fiyatlari](https://portal1.tcdd.gov.tr/tcdd(bD10ciZjPTEwMCZkPW1pbg==)/zy02/yuk_tasima_fiyatlari?menuId=https://portal1.tcdd.gov.tr/tcdd(bD10ciZjPTEwMCZkPW1pbg==)/zy02/yuk_tasima_fiyatlari),
(Data Download Date: 05.01.2016)
75. Turkish Airlines (2016),
<http://www.turkishcargo.com.tr/tr/e-kargo/kargo-ucretleri>,
(Data Download Date: 05.01.2016).
76. SEAGO LINE, (2016),
<http://www.seagoline.com/local-offices/turkey-turkish/freetime-demurrage-detention/ardiye-free-sure-ve-tarife-bilgileri/> ,
(Data Download Date: 05.01.2016).
77. Antalya Serbest Bölge İşleticisi A.Ş., (2016),
http://www.asbas.com.tr/asbas_antalya_serbest_bolgesi-tarifeler.asp,
(Data Download Date: 05.01.2016).
78. KUMPORT, (2016),
http://www.kumport.com.tr/hizmet_tarife_konteyner.html,
(Data Download Date: 05.01.2016).
79. Turkish State Railways (2016),
<http://www.tcdd.gov.tr/files/yuk/tarife.pdf>,

(Data Download Date: 05.01.2016).

80. Samsunport Internatioanal, (2016),

<http://www.samsunport.com.tr/pdf/tarife.pdf>,

(Data Download Date: 05.01.2016).

81. Gemlik Liman ve Depolama İşlemleri A.Ş., (2016),

<http://www.gemport.com.tr/sayfalar.asp?pageID=TarifeHesapla>,

(Data Download Date: 05.01.2016).

82. Mersin International Port (2016),

<http://www.mersinport.com.tr/images/pdf/tarife.pdf>,

(Data Download Date: 05.01.2016).

APPENDICES A

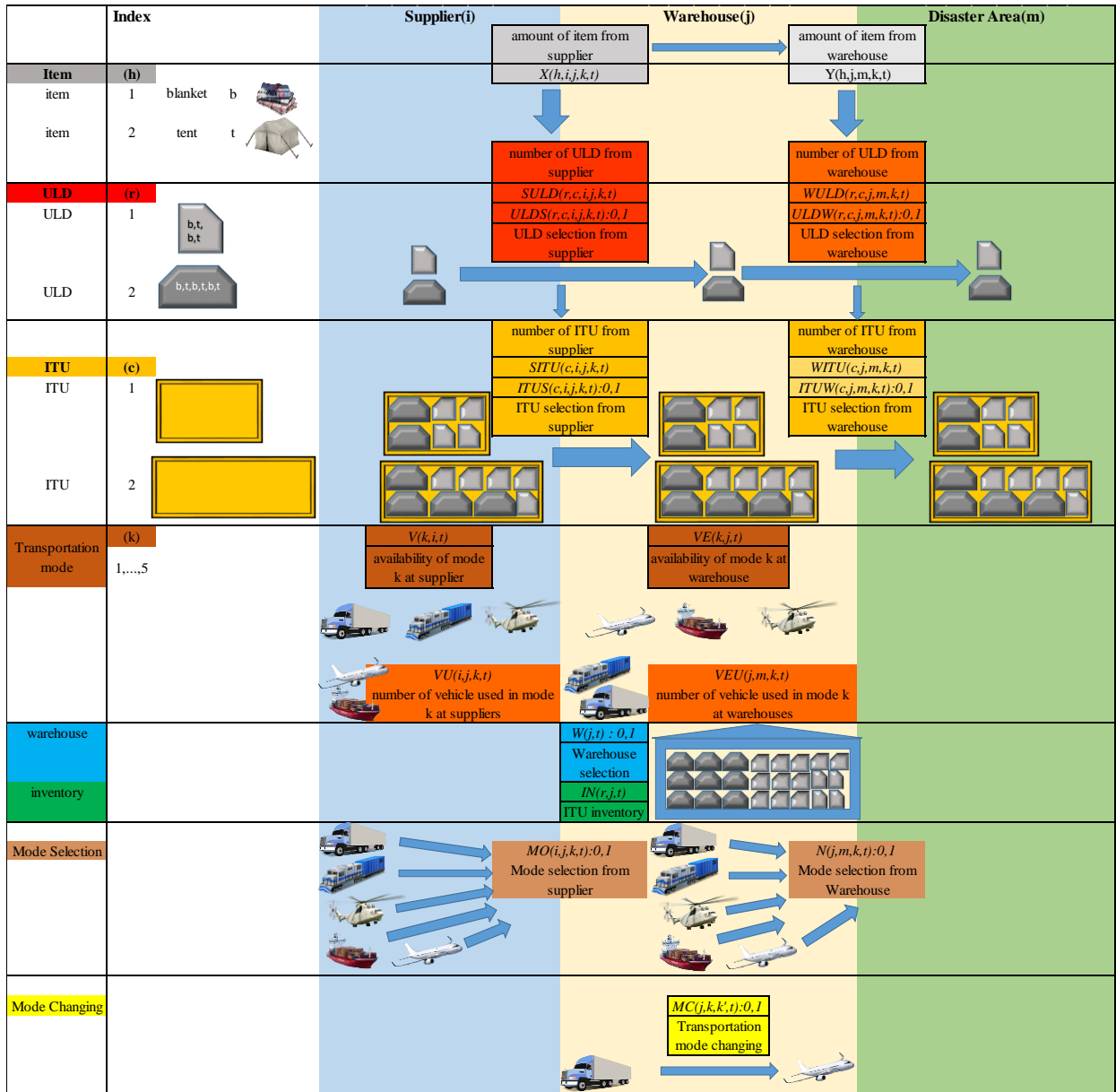

Figure A. 1 Illustration of conceptual model with vehicles are represented by integers.

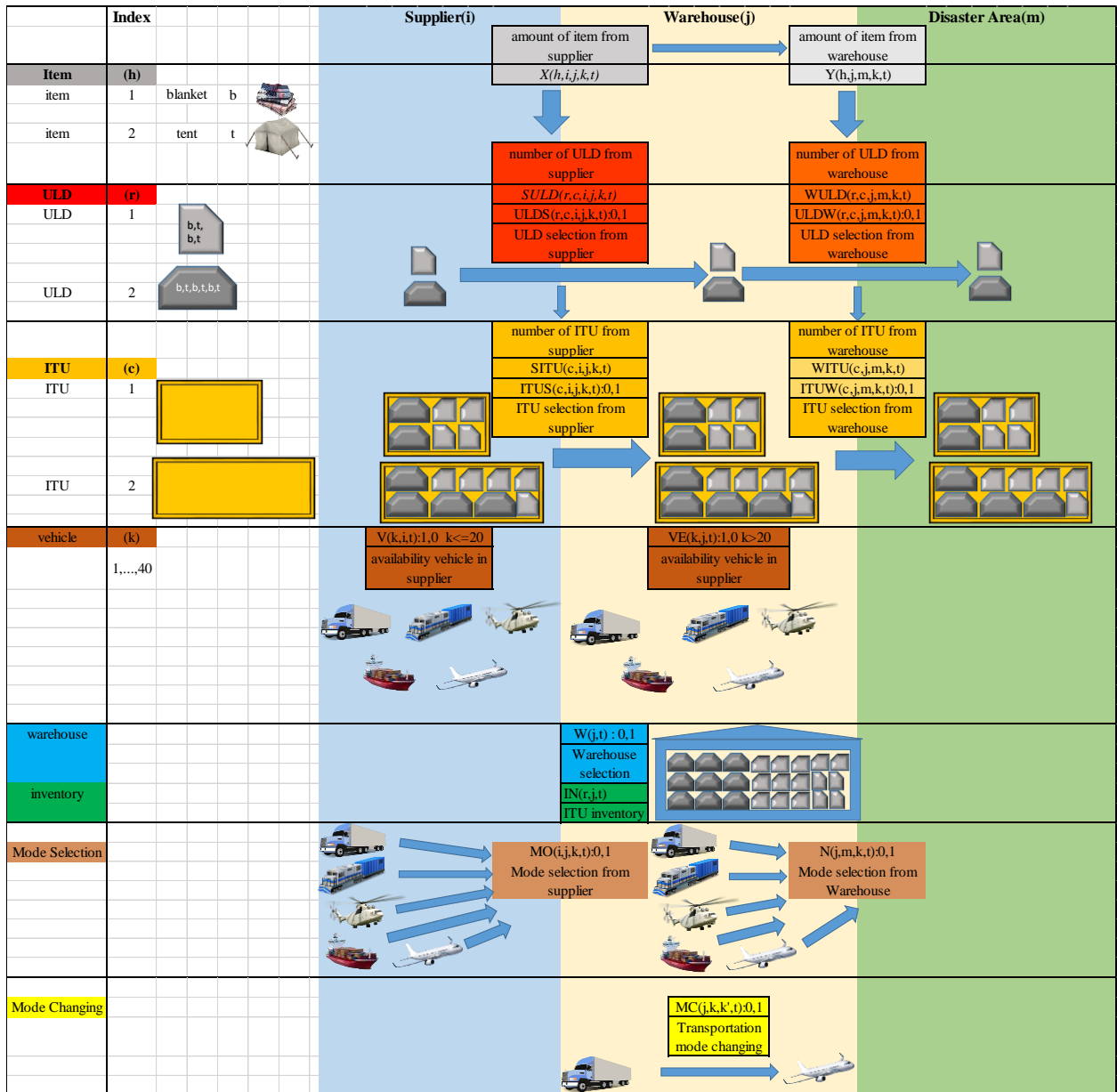

Figure A. 2 Illustration of conceptual model with vehicles are represented by binaries.

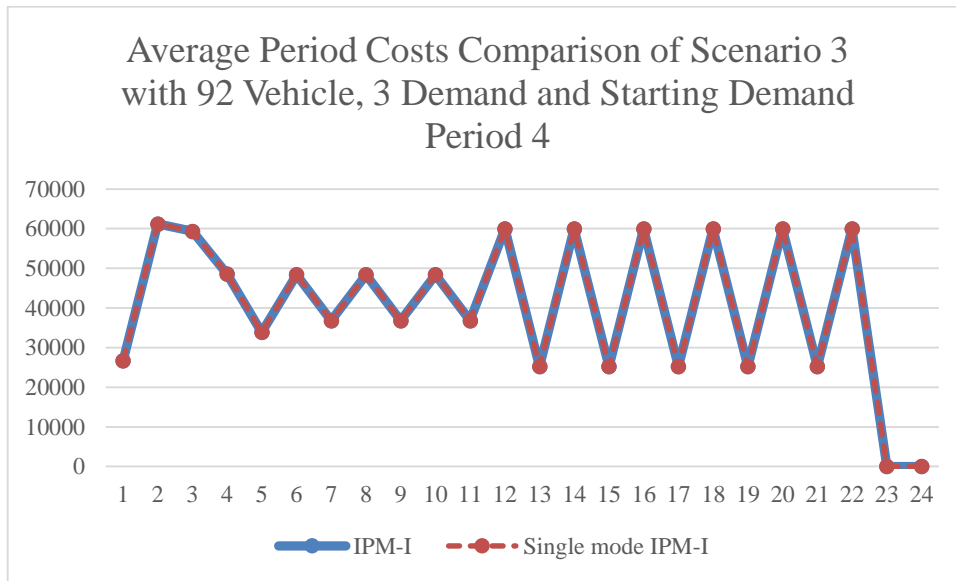

Figure A. 3 Average period costs comparison for IPM-I and single mode IPM-II in scenario 3.

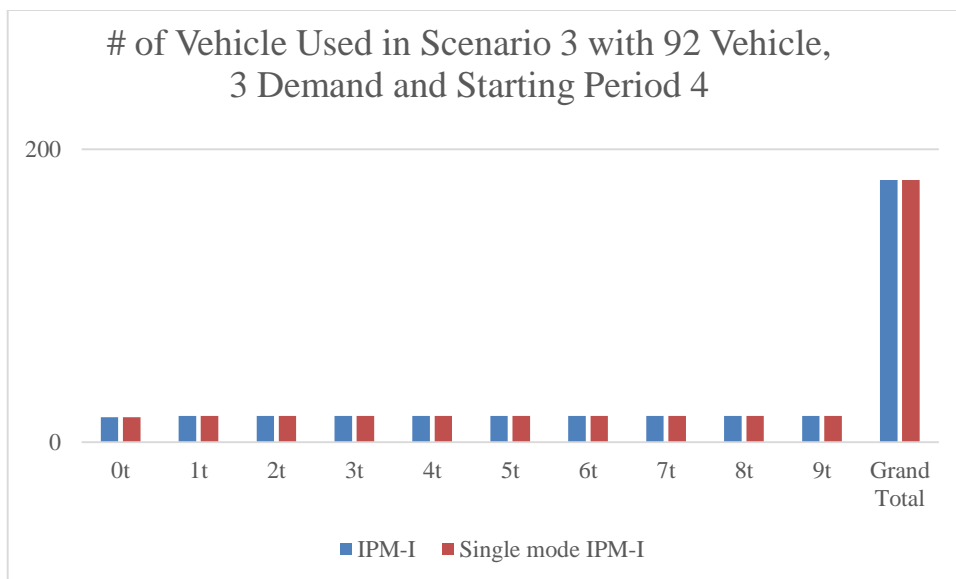

Figure A. 4 Number of vehicle used of IPM-I and single mode IPM-II in scenario 3.

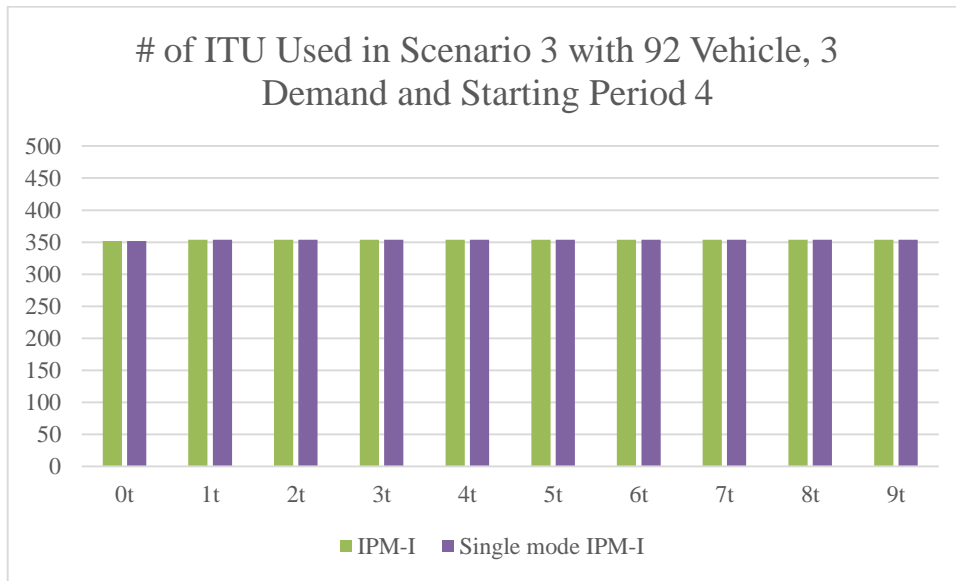

Figure A. 5 Number of ITU used of IPM-I and single mode IPM-II in scenario 3.

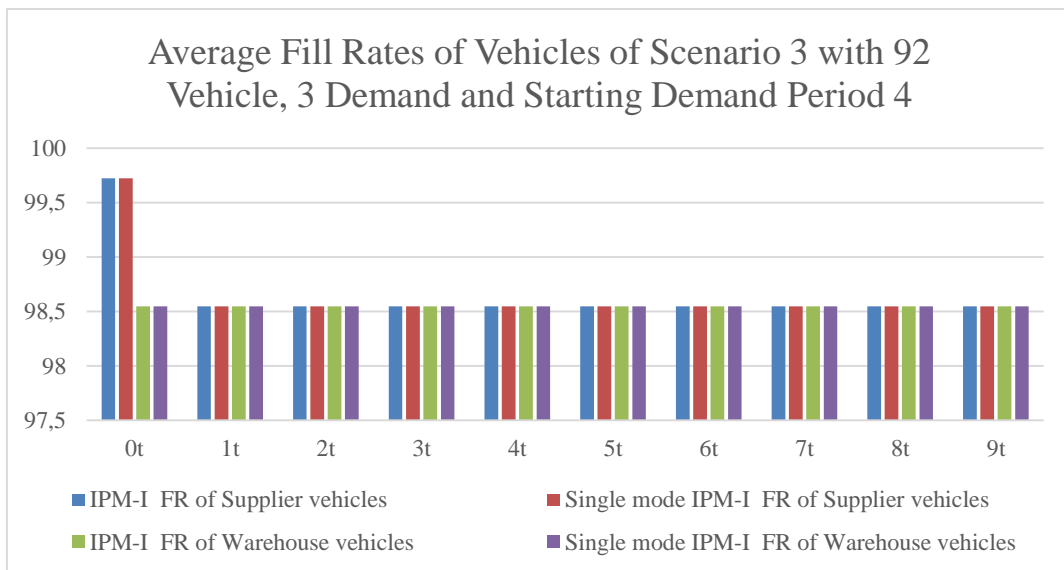

Figure A. 6 Average fill rates of IPM-I and single mode IPM-II in scenario 3.

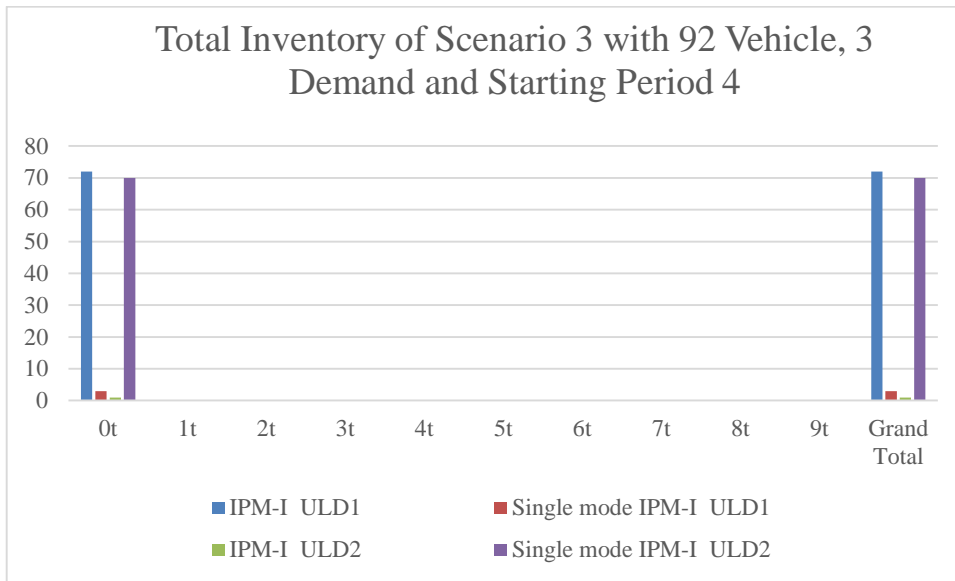

Figure A. 7 Number of total ULDs stored in scenario 3.

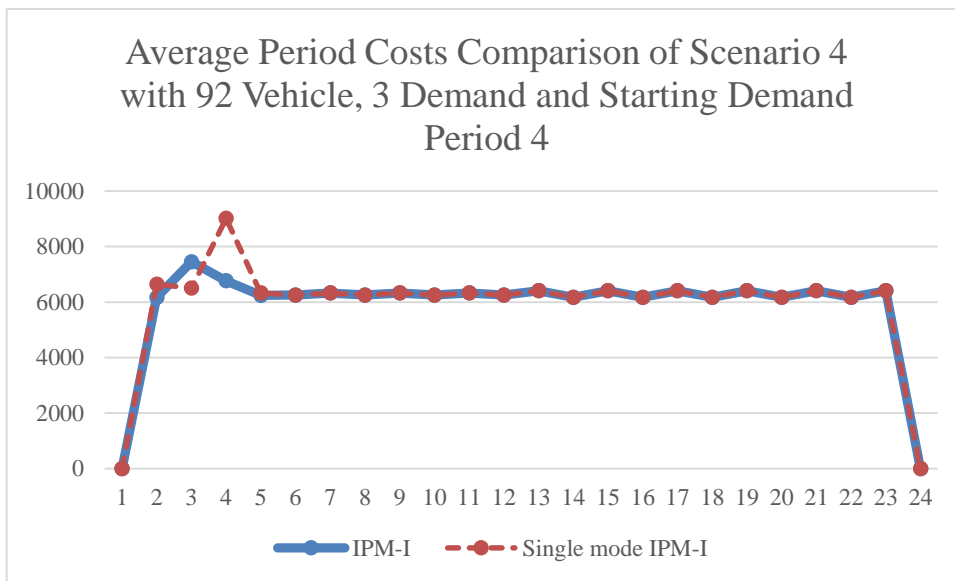

Figure A. 8 Average period costs comparison for IPM-I and single mode IPM-II in scenario 4.

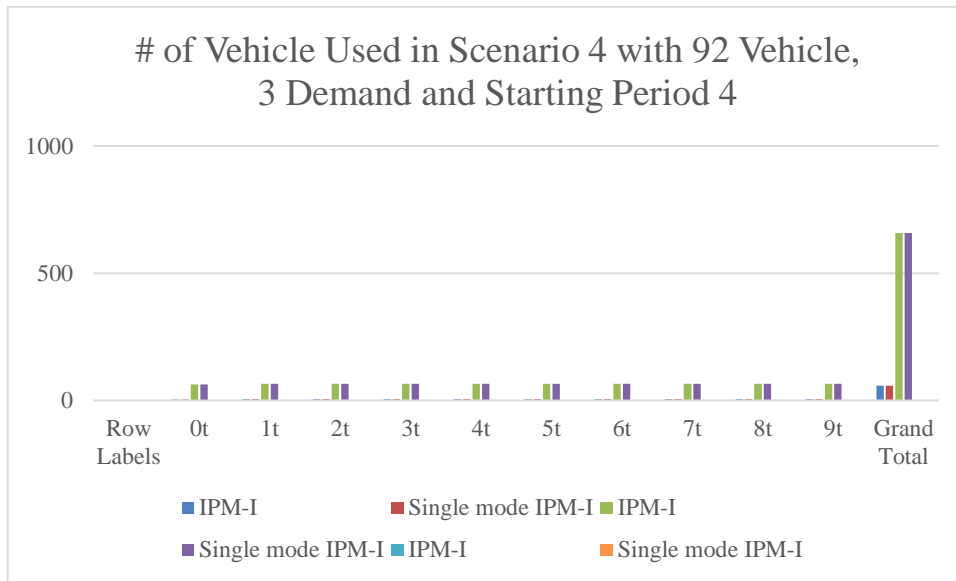

Figure A. 9 Number of vehicle used of IPM-I and single mode IPM-II in scenario 4.

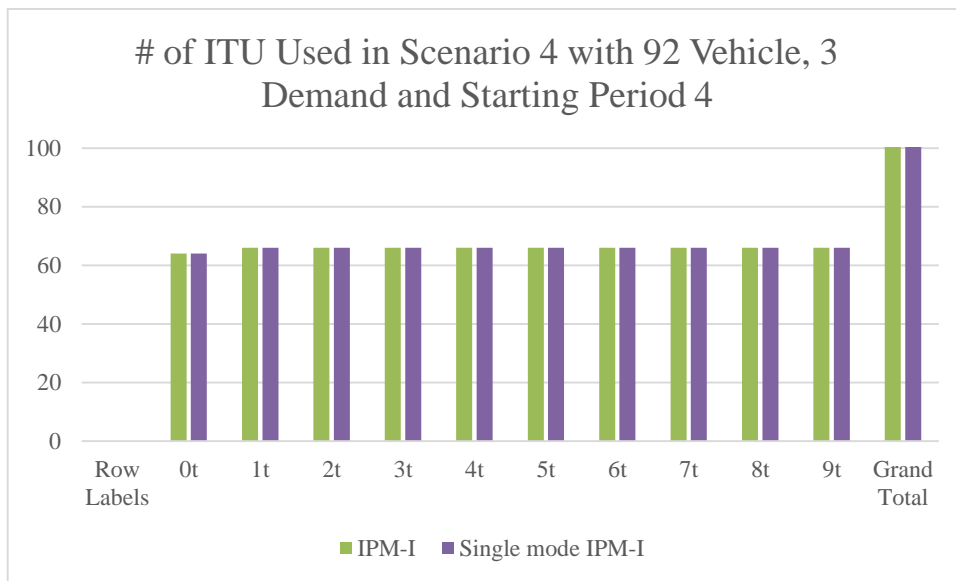

Figure A. 10 Number of ITU used of IPM-I and single mode IPM-II in scenario 4.

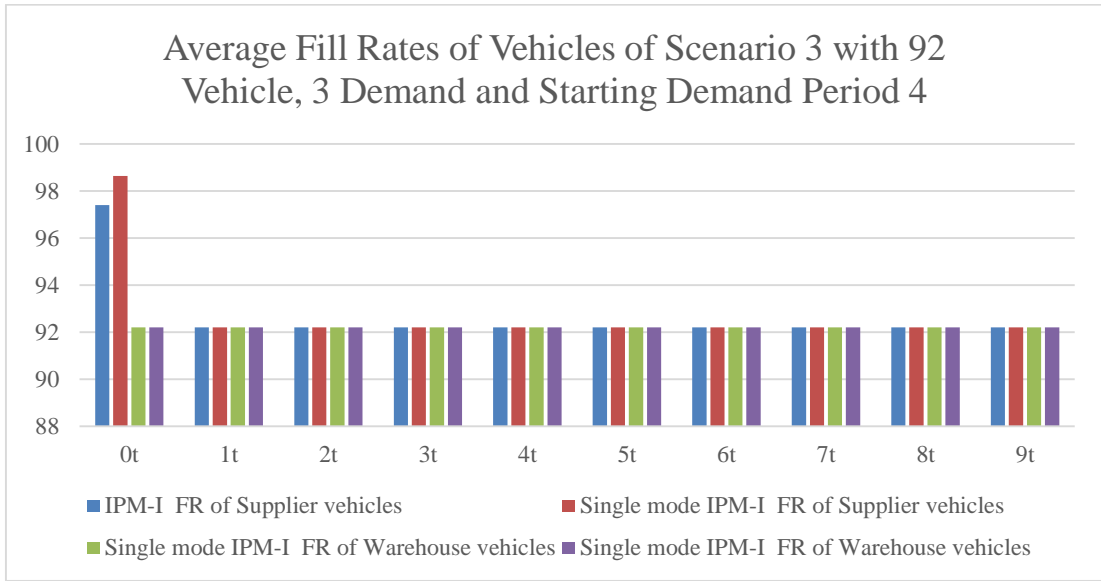

Figure A. 11 Average fill rates of IPM-I and single mode IPM-II in scenario 4.

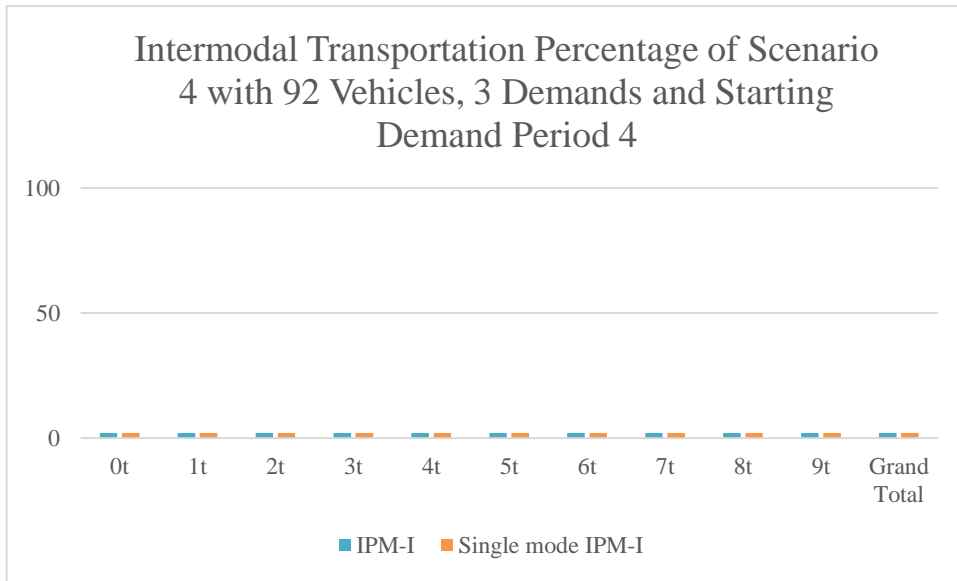

Figure A. 12 Intermodal transportation percentages of instances scenario 4.

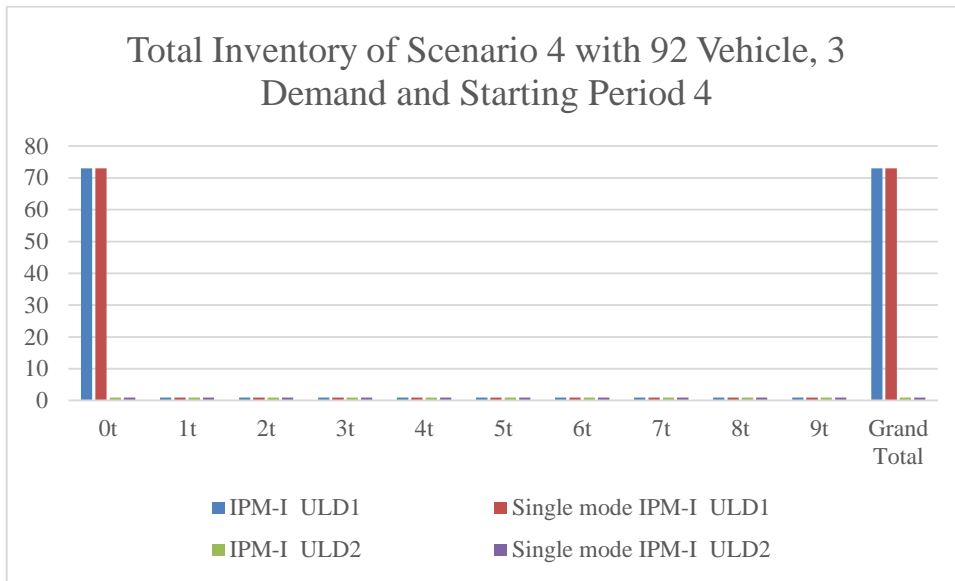

Figure A. 13 Number of total ULDs stored in scenario 4.

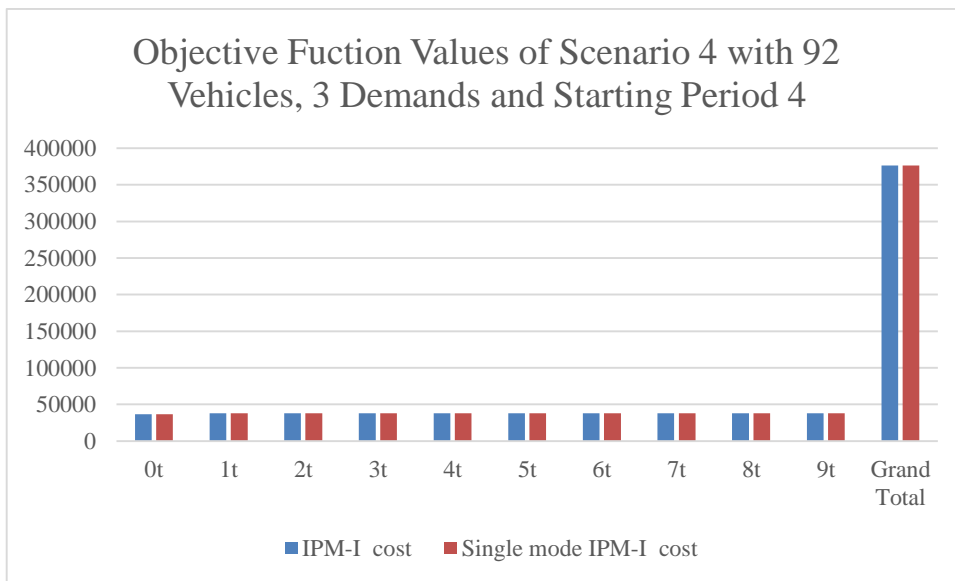

Figure A. 14 Objective function value of IPM-I and single mode IPM-II in scenario 4.

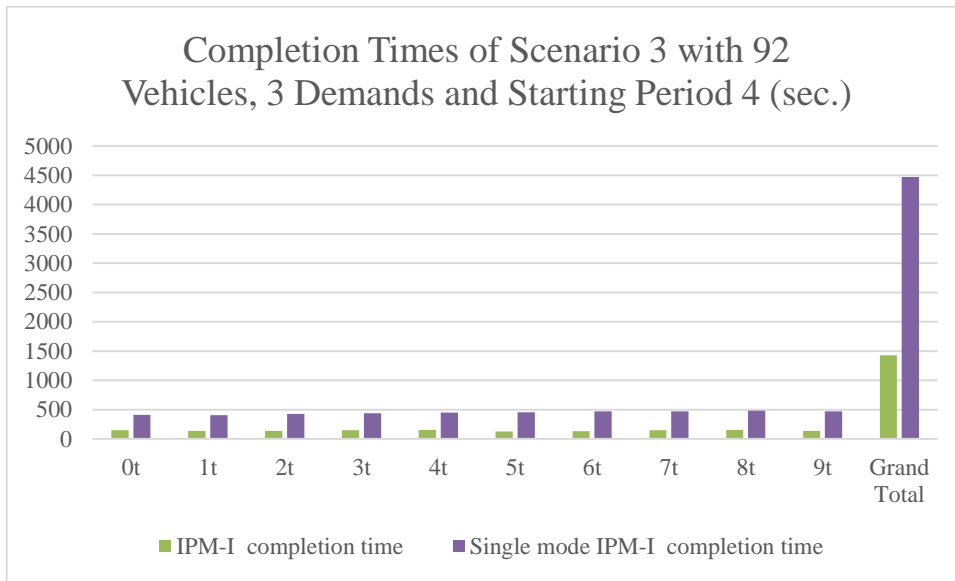

Figure A. 15 Intermodal transportation percentages of instances scenario 4.

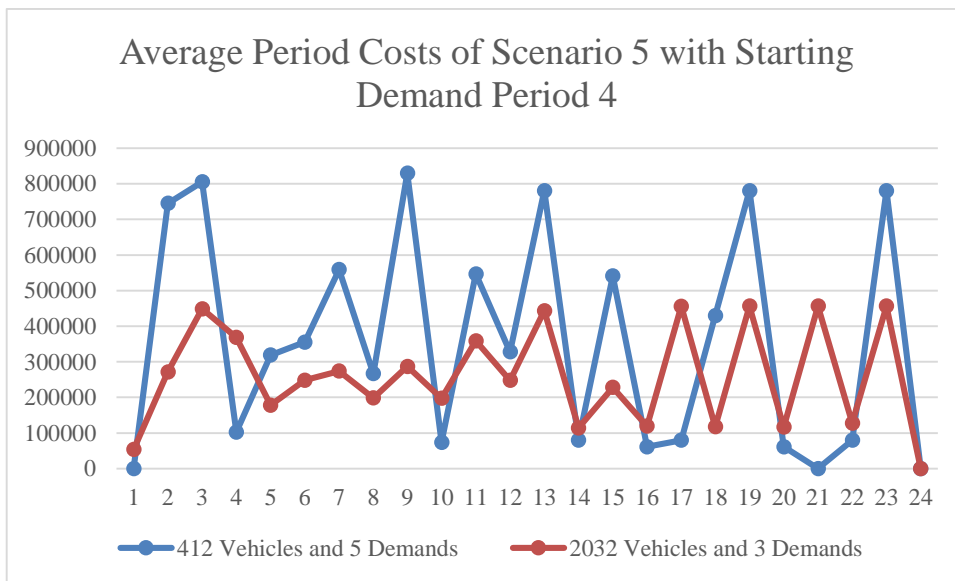

Figure A. 16 Period costs of scenario 5.

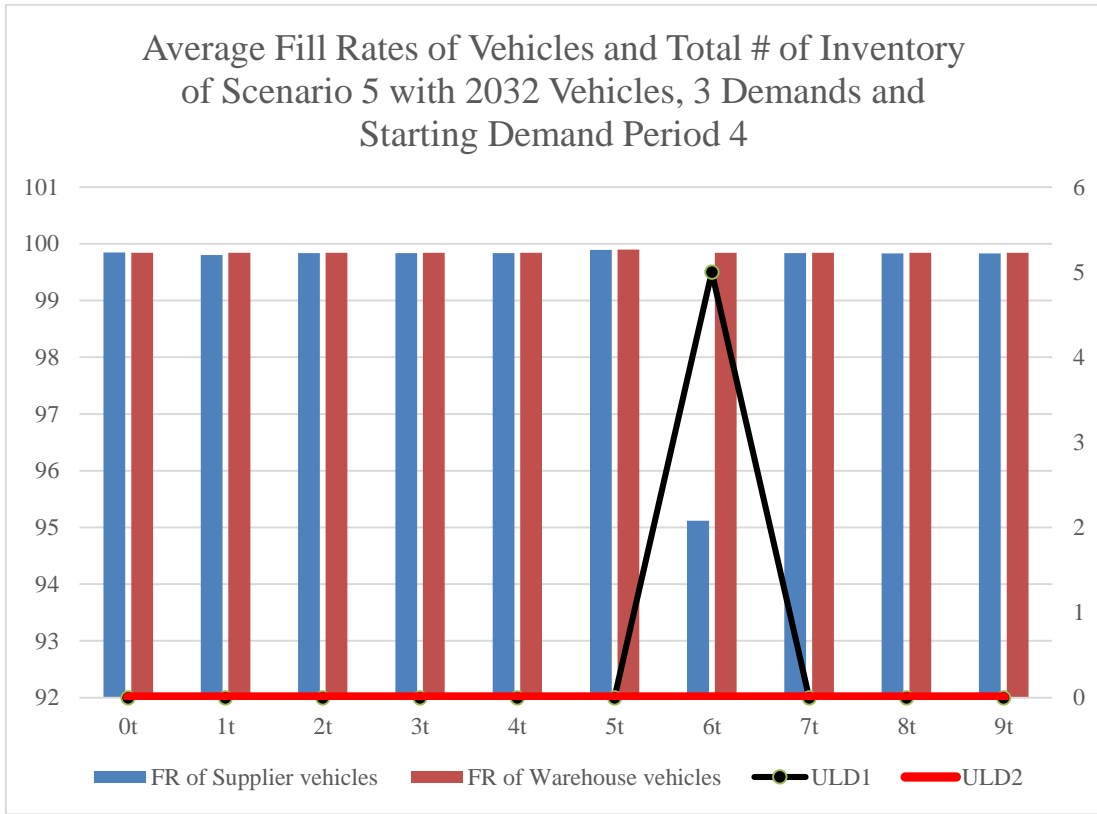

Figure A. 17 Average fill rates and total inventory of scenario 5 with 2032 vehicles

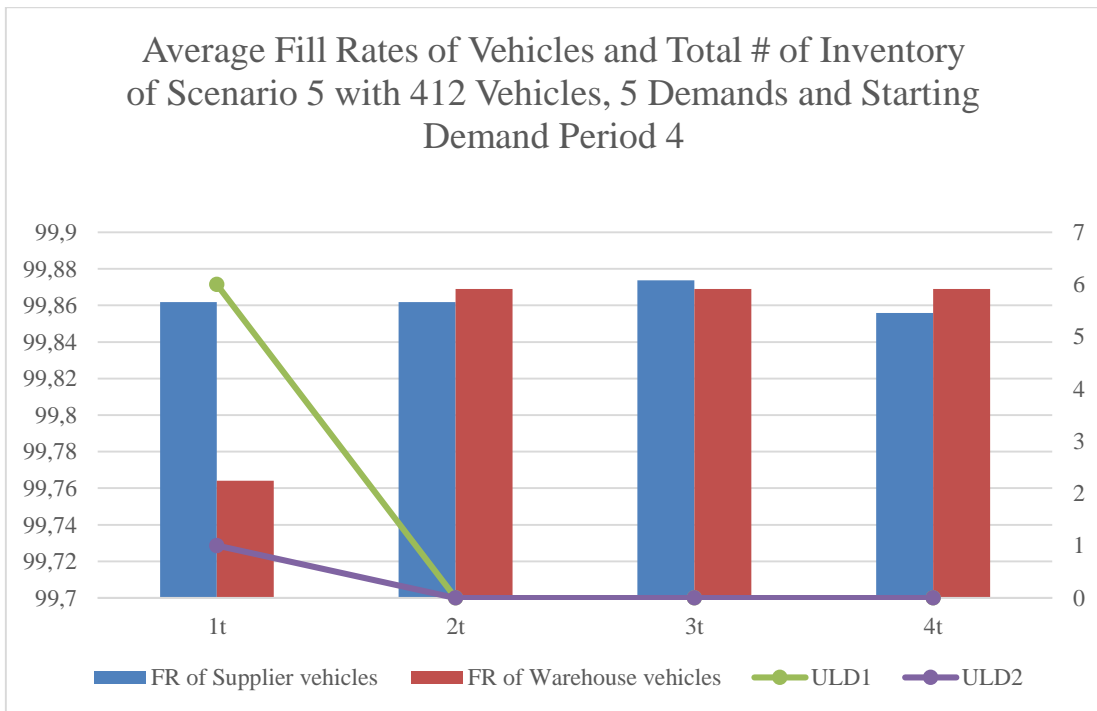

Figure A. 18 Average fill rates and total inventory of scenario 5 with 412 vehicles

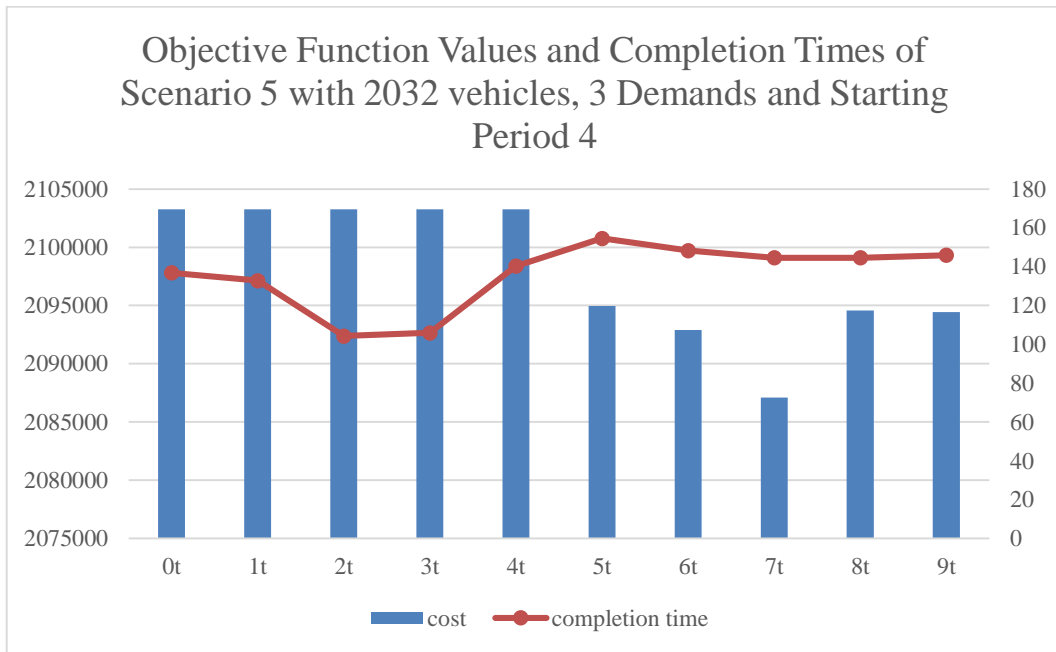

Figure A. 19 Objective function values and completion times of scenario 5.

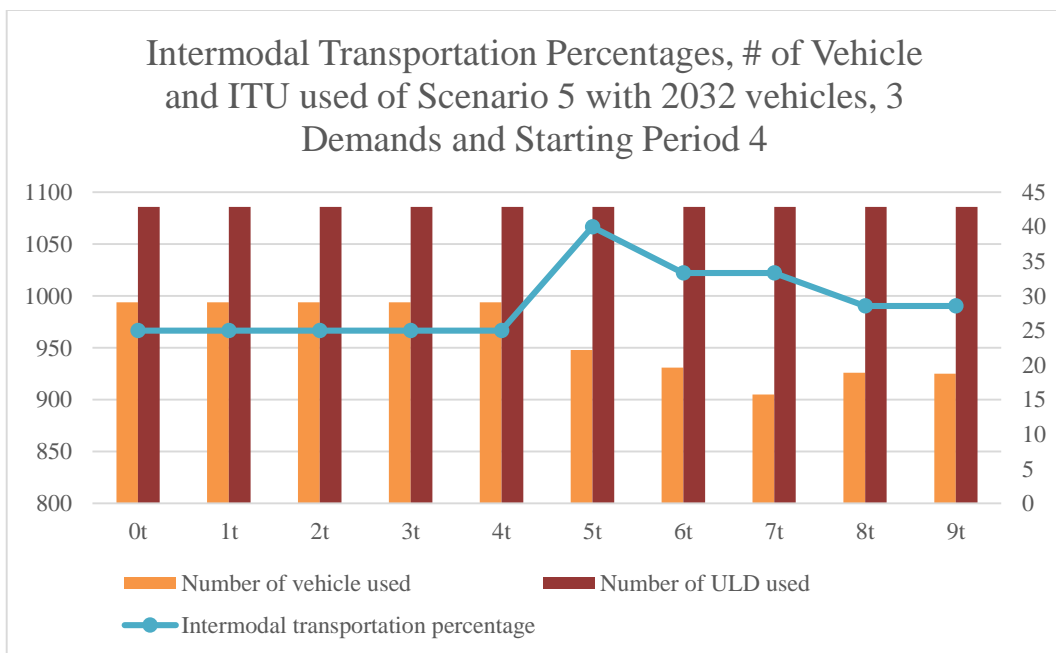

Figure A. 20 Intermodal transportation percentages, number of vehicle and ITU used of scenario 5.

APPENDICES B

Table B. 1 Allocation of vehicle sources (412, 872 and 2032)

	Truck	Container Ship	Freight Train	Air Freighter	Helicopter	Total
Supplier1	40	20	20	3	20	103
Supplier 2	40	20	20	3	20	103
Warehouse 1	40	20	20	3	20	103
Warehouse 2	40	20	20	3	20	103
Total	160	80	80	12	80	412
Supplier1	200	3	5	5	5	218
Supplier 2	200	3	5	5	5	218
Warehouse 1	200	3	5	5	5	218
Warehouse 2	200	3	5	5	5	218
Total	800	12	20	20	20	872
Supplier1	500	2	2	2	2	508
Supplier 2	500	2	2	2	2	508
Warehouse 1	500	2	2	2	2	508
Warehouse 2	500	2	2	2	2	508
Total	2000	8	8	8	8	2032

Table B. 2 Number of ITU used to transport ULDs from warehouses to disaster area in 92BV3D0T4

ITU type	Warehouse	Disaster area	Vehicle	Period 3	Period 4	Period 5
ITU1	Izmir	Denizli	rail11	8		
ITU1	Antalya	Denizli	rail16			8
ITU1	Antalya	Denizli	rail18		8	

Table B. 3 Number of ULD used from warehouses to disaster area in 92BV3D0T4

ITU type	ULD type	Warehouse	Disaster area	Vehicle	Period 3	Period 4	Period 5
ITUT1	ULDT1	Izmir	Denizli	rail11	6		
ITUT2	ULDT1	Izmir	Denizli	rail11	50		
ITUT2	ULDT1	Antalya	Denizli	rail16			54
ITUT2	ULDT1	Antalya	Denizli	rail18		54	

Table B. 4 Cost and completion time results of scenario 3 with 3 demand, 40 integer vehicle

# of period between demands	start of demand	infeasible	optimal	relative gap	absolute gap	cost	completion time
0t	t4	1	0			0	143.8
1t	t4	1	0			0	129.5
2t	t4	1	0			0	138.1
3t	t4	0	1	0	0	630615	146.5
4t	t4	0	1	0	0	632912	161.7
5t	t4	0	1	0	0	627090	174.3
6t	t4	0	1	0	0	437046	201.2
7t	t4	0	1	0	0	437046	226.8
8t	t4	0	1	0	0	437046	163.1
9t	t4	0	1	0	0	437046	163.9

Table B. 5 Infeasible instances for single mode modified IPM-I

# of vehicle	vehicle rep. Style	scerio no	# of demand	# of period between demands	start of demand	cost	completion time
412	singlemode	s2	3	0t	t16	0	555.09
412	singlemode	s2	3	1t	t16	0	570.15
412	singlemode	s2	5	0t	t4	0	789.00
412	singlemode	s2	5	1t	t4	0	804.91
412	singlemode	s2	5	2t	t4	0	782.30
412	singlemode	s2	5	3t	t4	0	800.99
412	singlemode	s2	5	4t	t4	0	833.65
412	singlemode	s2	5	0t	t16	0	1025.48
92	singlemode	s2	3	0t	t4	0	197.90
92	singlemode	s2	3	1t	t4	0	209.36
92	singlemode	s2	3	2t	t4	0	225.59
92	singlemode	s2	3	3t	t4	0	224.79
92	singlemode	s2	3	4t	t4	0	245.11
92	singlemode	s2	3	5t	t4	0	256.20
92	singlemode	s2	3	6t	t4	0	254.94
92	singlemode	s2	3	7t	t4	0	272.34
92	singlemode	s2	3	8t	t4	0	279.58
92	singlemode	s2	3	9t	t4	0	301.11

APPENDICES C

CURRICULUM VITAE

PERSONAL INFORMATION

Surname, Name: KAVLAK, Hasan

Nationality: Turkish (TC)

Date and Place of Birth: 01 April 1986, Kırşehir

Marital Status: Married

Phone: +90 555 375 82 21

email: hasankavlak@gmail.com



EDUCATION

Degree	Institution	Year of Graduation
M.Sc.	Çankaya University/ Industrial Engineering	2016
B.Sc.	Çankaya University/ Industrial Engineering	2010
High School	Metin Nuran Çakallıklı Anatolian High School, Antalya	2004

WORK EXPERIENCE

Year	Place	Enrollment
2012-present	Çankaya University/ Dept. of Industrial Engineering	Expert
2011-2012	Bozankaya Oto. Mak. İml. A.Ş	Purchasing and MRP Engineer

2009-2010	Çesan A.Ş	Senior Project Student
2009 June	TUSAŞ AEROSPACE INDUSTRIES,INC	Intern Engineering Student
2008 June	Türk Traktör ve Ziraat Makineleri AŞ	Intern Engineering Student
2006 June – 2006 September	Enkay Döküm Teknolojileri Mak. San. İmalat İnş. İth. ve İhracat Ltd. Şti.	Quality Controller

FOREIGN LANGUAGES

Advanced English.