



SMART HOME DESIGN WITH IOT (HOME AUTOMATION)

YASSER SAMIR HADI AL-SAMARRAEI

JULY 2018

SMART HOME DESIGN WITH IOT (HOME AUTOMATION)

**A THESIS SUBMITTED TO
THE GRADUATE SCHOOL OF NATURAL AND APPLIED
SCIENCES OF
ÇANKAYA UNIVERSITY**

**BY
YASSER SAMIR HADI AL-SAMARRAEI**

**IN PARTIAL FULFILLMENT OF THE REQUIREMENTS FOR THE
DEGREE OF
MASTER OF SCIENCE
IN
THE DEPARTMENT OF
COMPUTER ENGINEERING**

JULY 2018

Title of the Thesis : **Smart Home Design with IoT (Home Automation)**

Submitted by **Yasser Samir Hadi AL-SAMARRAEI**

Approval of the Graduate School of Natural and Applied Sciences, Çankaya University.

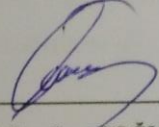

Prof. Dr. Can ÇOĞUN
Director

I certify that this thesis satisfies all the requirements as a thesis for the degree of Master of Science.

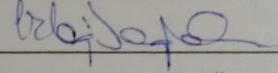

Prof. Dr. Erdoğan DOĞDU
Head of Department

This is to certify that we have read this thesis and that in our opinion it is fully adequate, in scope and quality, as a thesis for the degree of Master of Science.

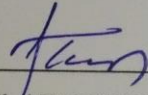

Dr. Sibel TARIYAN ÖZYER
Supervisor

Examination Date: 06.07.2018

Examining Committee Members

Assoc. Prof. Dr. Ihsan Tolga MEDENİ (Ankara Yıldırım Beyazıt Univ.)

Dr. Sibel TARIYAN ÖZYER (Çankaya Univ.)

Dr. Abdül Kadir GÖRÜR (Çankaya Univ.)

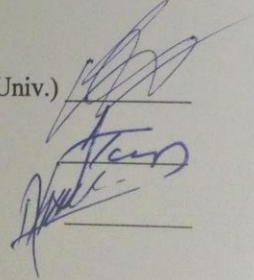

STATEMENT OF NON-PLAGIARISM PAGE

I hereby declare that all information in this document has been obtained and presented in accordance with academic rules and ethical conduct. I also declare that, as required by these rules and conduct, I have fully cited and referenced all material and results that are not original to this work.

Name, Last Name: Yasser Samir Hadi, AL-SAMARRAEI

Signature



Date

: 06.07.2018

ABSTRACT

SMART HOME DESIGN WITH IOT (HOME AUTOMATION)

AL-SAMARRAEI, Yasser Samir Hadi
M.Sc., Department of Computer Engineering
Supervisor: Dr. Sibel TARIYAN ÖZYER

July 2018, 50 pages

Smart home's conception has been growing topic in our modern community. The content of smart automated items, such as home electronic devices, communicate together with users. These devices are quite expensive when compared to non-intelligent devices.

In this thesis, a Home Automation system has been studied and developed to automate existing appliances by supporting them with modern smart technology. In this effective way, the cost can be lowered with upgrading the automating system instead of replacing entire the items.

A Home Automation System has been implemented and designed to solve several common issues in this thesis. IoT security items have been investigated with the smart house (Home Automation) and clarified to become a basic stage of the Home Automation system. Smart home (Home Automation) application is designed to monitor and secure the home security sensors. An application has been performed to monitor and control the smart home system.

The system is based on hardware and software components (such as Arduino Mega 2560) and can be acted as a security guard of the home. The system has been designed to monitor the humidity, temperature, light, gas, fire, burglar alarm in the house and has a passive-infrared sensor to make sure that the family is safe. Sensors have been used on windows and doors to monitor any unauthorized intruder or in case of forgetting to close it. In addition, the system is also connected with GSM system (Global System for Mobile communication) to send notification SMS message (Short Message Service) to specific destinations in case of detecting something from sensors while “the system activated” mode on. The system (equipment of the home design) also has been controlled by using android application via Bluetooth.

Keywords: Home Automation, Smart Home, Arduino Mega 2560, GSM (Global System for Mobile communication), SMS (Short Message Service), Bluetooth.

ÖZ

NESNELERİN İNTERNETİ İLE AKILLI EV TASARIMI (EV OTOMASYONU)

AL-SAMARRAEI, Yasser Samir Hadi
Yüksek Lisans, Bilgisayar Mühendisliği Bölümü
Tez Yöneticisi: Dr. Sibel TARIYAN ÖZYER

Temmuz 2018, 50 sayfa

Akıllı ev kavramı modern toplumumuzda gelişmekte olan bir konudur. Ev elektronik cihazları gibi akıllı otomasyon bileşenleri kullanıcılarla iletişim kurarlar. Bu cihazlar akıllı olmayan cihazlarla karşılaştırıldığında oldukça pahalıdır.

Bu tez çalışmasında, bir ev otomasyon sistemi çalışılmış ve varolan cihazların otomasyonu modern akıllı teknoloji desteği sağlanarak geliştirilmiştir. Bu etkili yönetimle, varolan cihazları değiştirmek yerine otomasyon sistemini güncelleyerek maliyet düşürülebilmiştir.

Bu tezde, ev otomasyon sistemi birçok genel problemi çözmek için uygulanmış ve tasarlanmıştır. Nesnelerin interneti güvenlik öğeleri akıllı ev (ev otomasyonu) ile araştırılmıştır ve ev otomasyon sistemi temel aşaması olarak açıklanmıştır. Akıllı ev (ev otomasyonu) uygulaması ev güvenlik algılayıcılarını izlemek ve güvenlik için tasarlanmıştır. Akıllı ev sistemi izlenmesi ve kontrolü için bir uygulama yapılmıştır.

Sistem donanım ve yazılım bileşenlerine dayalıdır (Arduino Mega 2560) ve evin güvenlik görevlisi gibi davranabilir. Sistem nem, gaz, ışık, yangın, hırsız alarmını

izlemek üzere tasarlanmıştır ve güvenlik için pasif kızılötesi algılayıcıya sahiptir. Kapı ve pencerelerde kapatılmasının unutulması durumunda herhangi bir yetkisiz davetsiz misafiri izlemek için algılayıcılar kullanılmıştır. Bunlara ek olarak; sistem, özel hedeflere algılayıcılardan “sistem aktive modunda” iken GSM sistemi ile bilgilendirme SMS mesajı göndererek bağlantı kurabilir. Sistem (tasarımdaki ev ekipmanları) Android uygulaması kullanılarak bluetooth aracılığıyla kontrol edilmiştir.

Anahtar Kelimeler: Ev otomasyonu, Akıllı ev, Arduino Mega 2650, GSM (Mobil İletişim için Küresel Sistem), SMS (Kısa Mesaj Servisi), Bluetooth.

ACKNOWLEDGEMENTS

I would like to thank all the former and present colleagues and friends at the Department of Computer Engineering for the contribution of the nice and friendly atmosphere here. Specially, I would like to express my deepest gratitude to my research supervisor Dr. Sibel TARIYAN ÖZYER for providing me with the opportunity to do this interesting work and giving me invaluable expertise throughout the work. His inspiring guidance, deep knowledge and patience have been invaluable for me and very much appreciated.

Last but not least, I would like to express my most sincere gratitude and respect to my brother (Dr. Ali Sameer Hadi HADI), wife (RIM TIAB) and my family for the help and spiritual encouragement, and for their patience, sacrifice and understanding. Without their help it would not have been possible to complete the thesis.

Many thanks also go to my other friends, thanks all of you for your friendship.

TABLE OF CONTENTS

STATEMENT OF NON PLAGIARISM.....	iv
ABSTRACT.....	v
ÖZ.....	vii
ACKNOWLEDGEMENTS.....	ix
TABLE OF CONTENTS.....	x
LIST OF FIGURES.....	xiii
LIST OF ABBREVIATIONS.....	xvi

CHAPTERS:

1. INTRODUCTION.....	1
1.1. Internet of Things (IoT).....	1
1.2. What is Home Automation	4
1.3. The Home Automation's Advantages	6
1.3.1. Saving energy with Home Automation.....	7
1.3.2. Healthcare with Home Automation.....	8
1.3.3. Low cost with Home Automation.....	9
1.3.4. Comfort and entertainment with Home Automation.....	9
1.4. Background and Motivation.....	10
1.5. Thesis Organization.....	11
2. LITERATURE REVIEW.....	12
2.1. Previous Studies	12
2.2. Arduino	14
2.2.1. What is Arduino board.....	15
2.2.2. Why Arduino boards.....	15
2.3. Arduino UNO R3.....	16

2.4.	Arduino Mega 2560.....	17
2.5.	Arduino Shields	18
2.6.	Arduino Programming Environment IDE.....	19
2.7.	Sensors.....	20
2.7.1.	RFID sensor.....	20
2.7.2.	Gas sensors.....	21
2.7.3.	Humidity & Temperature sensor.....	21
2.7.4.	Motion sensor PIR.....	22
2.7.5.	Flame sensor.....	22
2.7.6.	Reed Switch sensor.....	23
2.8.	Keypad 4x4.....	23
2.9.	Servo Motor.....	24
2.10.	Relay.....	25
2.11.	Buzzer.....	26
2.12.	LCD 16x2.....	26
2.13.	I2C LCD Expansion.....	27
2.14.	Low-Energy Bluetooth.....	27
2.15.	RGB LED.....	28
2.16.	SIM800L.....	28
2.17.	MIT APP INVENTOR 2.....	29
3.	IMPLEMENTATION.....	30
3.1.	Front Door Security System (FDSS).....	30
3.1.1.	System description.....	30
3.1.2.	How Front Door Security System (FDSS) works.....	34
3.1.3.	Most challenges that fixed in Front Door Security System (FDSS).....	35
3.2.	System Alarm and Control Unit (SACU).....	37
3.2.1.	System discretion.....	37
3.2.2.	How System Alarm and Control Unit (SACU) works....	41

3.2.3.	Most challenges that fixed in System Alarm and Control Unit (SACU)	42
3.3.	Home Automation Android Application.....	44
3.3.1.	Application description.....	44
3.3.2.	How Home Automation Android application works.....	44
3.4.	Novelty and Comparison with other Similar Systems.....	48
4.	CONCLUSION, LIMITATION AND FUTURE WORK.....	49
4.1.	Conclusion.....	49
4.2.	Limitation.....	50
4.3.	Future Work.....	50
	REFERENCES.....	R1
	APPENDICES.....	A1
A.	CURRICULUM VITAE.....	A1

LIST OF FIGURES

FIGURES

Figure 1	Internet of Things (IoT) architecture.....	3
Figure 2	Home Automation's advantages based on IoT.....	6
Figure 3	Arduino company logo.....	14
Figure 4	Arduino UNO R3 board.....	16
Figure 5	Arduino Mega 2560 board.....	17
Figure 6	Arduino Ethernet shield.....	18
Figure 7	Arduino software IDE.....	19
Figure 8	RFID-RC522 sensor.....	20
Figure 9	Gas sensor MQ-6.....	21
Figure 10	Humidity & Temperature sensor DHT22.....	21
Figure 11	Motion sensor PIR HC-RS501.....	22
Figure 12	Flame sensor for Arduino.....	22
Figure 13	Reed Switch sensor for Arduino.....	23
Figure 14	Keypad for Arduino 4x4.....	23
Figure 15	Servo Motor for Arduino.....	24
Figure 16	Relay for Arduino 2 channel.....	25
Figure 17	Relay for Arduino 4 channel.....	25

FIGURES

Figure 18	Regular Buzzer for Arduino.....	26
Figure 19	Passive Buzzer for Arduino.....	26
Figure 20	LCD 16x2 for Arduino.....	26
Figure 21	I2C expansion for Arduino LCD.....	27
Figure 22	Bluetooth HC-06/ZS-040 device.....	27
Figure 23	RGB LED for Arduino.....	28
Figure 24	Sim800L GSM for Arduino.....	28
Figure 25	Block diagram for Front Door Security System (FDSS).....	31
Figure 26	Front Door Security System (FDSS) architecture.....	32
Figure 27	Front Door Security System (FDSS) real components.....	33
Figure 28	Front Door Security System (FDSS) flow chart.....	36
Figure 29	Block diagram for System Alarm and Control Unit (SACU).	38
Figure 30	System Alarm and Control Unit (SACU) architecture.....	39
Figure 31	System Alarm and Control Unit (SACU) real components...	40
Figure 32	System Alarm and Control Unit (SACU) flow chart.....	43
Figure 33	Home Automation application flow chart.....	45

FIGURES

Figure 34	Home Automation android application GUI design.....	46
Figure 35	Home Automation android application block code.....	46
Figure 36	The main page of Home Automation application.....	47



LIST OF ABBREVIATIONS

IoT	Internet of Things
GSM	Global System for Mobile communication
SMS	Short Message Service
RFID	Radio-Frequency Identification
CCU	Central Control Unit
CCTV	Closed-Circuit Television
IDE	Integrated Development Environment
PWM	Pulse Width Modulation Outputs
PIR	Passive Inferred sensor
LCD	Liquid Crystal Display
I2C	Inter-Integrated Circuit
GUI	Graphical User Interface
FDSS	Front Door Security System
SACU	System Alarm and Control Unit
MMS	Multimedia Messaging Service

CHAPTER 1

INTRODUCTION

1.1. Internet of Things (IoT)

From the beginning of the Internet's establishing in 1989, was linked Things with the internet over a wide area. The first implementation of this type can possibly be Trojan Room Coffee Pot. In 1990 the first Internet 'device' was founded by John Romkey, also over the internet, a toaster could have controlled by turning this device on and off. In 1994, the Wear Cam has been created by Steve Mann. In 1997, the first brief acknowledgment related to the sensors and sensors' future was given by Paul Saffo. The term of Internet of Things (IoT) was named by Kevin Ashton (K.A. Executive director of the MIT Auto-ID Centre). In the same year of giving the name (IoT) in 1999, the global RFID (Radio-Frequency Identification) was invented based on the object of identification system by staff of the Auto - ID Centre. In 2003, RFID (Radio-Frequency Identification) was developed at a high level in US army with a special program (called Savi). In 2008 a several of companies released the IPSO (Alliance) to increase the use of Internet Protocol (IP) in networks of Smart Objects, the purpose of working together is to activate the Internet of Things(IoT) [1].

The Internet of Things (IoT) technology can be easily described as a linking between humans, computers and things. All the objects (electronic devices) that we use in whole life possible to be controlled and monitored by implementing the items of Internet of Things (IoT). Most of the operation is processed with the sensors' assist in Internet of Things (IoT). In daily life, sensors are designed in every place in the world, and these sensors' work is to change the physical information into digital data and send these data to central control unit (CCU). In this case, any device can be monitored and controlled remotely from any place in the world via Internet.

The architecture of such a system is based on specific of operations and processes in scenarios of real-time [2].

The Internet of Things (IoT) is defined in several ways. Widely, it's possible to be used like this definition:

“A dynamic global network infrastructure with self-configuring capabilities based on standard and interoperable communication protocols where physical and virtual ‘things’ have identities, physical attributes, and virtual personalities and use intelligent interfaces, and are seamlessly integrated into the information network” [3].

Wide field of challenges is appeared due to the huge number of connecting devices to the internet. By 2020, several billions of smart objects or devices will have connected with the internet according to the researchers' expectation [4].

With IoT technology, the users are provided better and high-quality services via real-time data processing, communications and visualization. IoT devices can be involved with almost every electronic device to be controlled and monitored remotely such as refrigerator, washing machine, hand watches, smart phones, home security, alarm system, etc. In close time, Internet of Things (IoT) will be able to link between connected systems with other groups of connected systems (applications, services and basic devices) and work all of them together via internet. In our time, the processing of all these services and electronic devices are done on their own architectures, protocol stacks and data structure. IoT still in primary levels of development until now, however the security of communication between items and devices are facing a weakness, interoperability and integration problems. In addition, these devices are required to be provided by a power, and sources of energy are too precious due to the fact that most of the energy provided by a battery or by harvesting energy [5].

Through the previous decades, humans have inspired in intensive way and taken their attentions by Internet of Things (IoT) due to a huge area of applications in factories, biomedical controlling, cultivation, smart cities, environmental observation and another fields Figure. 1.

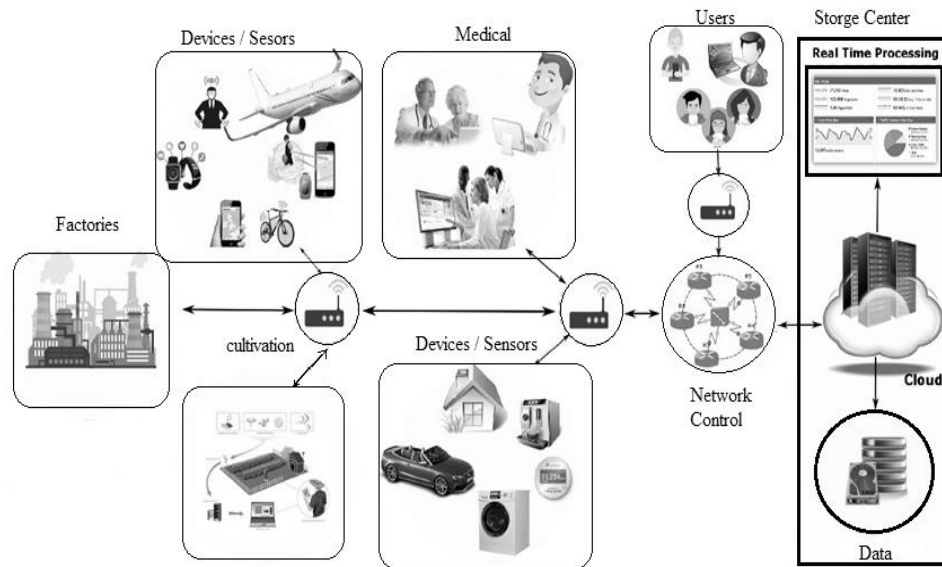

Figure. 1: Internet of Things (IoT) architecture.

Internet of Things (IoT) is the communications with physical devices are used in our world that use fix communications architectures to supply new facilities and services to serve the humanity.

From a concept of IoT, the IoT's elements can be summarized into a simple form of the equation as follow:

IoT = Human (users) + Physical items (devices, sensors, controllers, storages) + Internet connections [6].

1.2. What is Home Automation

The concept of Home Automation (Smart Home) means automating and controlling the electronic devices and electrical items are used in our homes, like house lamps, humidity and temperature, fans, locks of door, etc. The subject of Home Automation (Smart Home) is not something founded recently, actually this topic was build and developed since the 1960s, based on Computer-Based System [7].

The topics of Home Automation (Smart Home) and Internet of Things (IoT) have closely related and tied to each other. Items of IoT, such as; smart temperature sensor, can be possibly controlled and monitored by smart devices (such as; smart phone, tablet, etc.). As a result, these can be expanded the range of worldwide due to ability of providing thus facilities via Internet. With the rising of smartphones' popularity together with IoT tools can be considered one of the important factors of separating Home Automation quickly and wildly these days [8]. IoT items with Home Automation devices are supplied and provided excellent optimization for energy-consuming by, for instance, activating a mode (Automatic Energy Saving) or giving brief details about energy-consumption in real-time to users. Furthermore, the cost can be high if classic electronic devices were to be changed by an IoT smart items. However, during changing to a smart-home, the biggest problem is by making compatibility between non IoT items with smart home system and make it work in an appropriate way [9].

One of the problems that obstacle people from adopting on the technologies of Smart Home is the installations of items (IoT smart devices). Continuously, the non-IoT items should be converted into smart items, and these operations have supposed to be done simply and easily manner. In this case, the users will be able to install the system without needing to make changes in hardware in the home. The item of it also has disadvantages, the main one is the communications between each other. The cooperation between technologies of smart home, like the diversity of communications protocols have been used, and that would be one of the important factors that hold back the customers from adopting with Home Automation systems. However, in order to achieve or provide maximum compatibility of communications

between the IoT items or trying to reach the ideal system of Home Automation, the communication protocols that supported the common customers' devices should be highly recommended [10].

Home Automation (smart home) is one of the important parts of IoT, smart home system has served customers in magnificent ways by communicating with different electronic items of IoT. People life has been changed, by the technology of smart home based on Internet of Things (IoT), through supplying connectivity to everybody without considering place and time [11] [12]. Recently, smart home systems have become growingly developed. Smart home systems have supplied methods and protocols to switch all kinds of items' information and services. Home Automation is a field of Internet of Things (IoT). At the same time, it is a group of hardware items that provide sensors, electronic objects, software, and network connection inside the house [13].

Smart home means that the building has automated by installing detections and control devices such as; lighting, humidity and temperature, security systems. Modern smart home systems are contained of smart sensors and switches the can be connected with central unit usually called Gateways. The user interface with Gateways together are interacted with smart-phones, tablets, or computers to control the smart home systems; the connections of a network of these systems are controlled and managed by Internet of Things (IoT) [14].

1.3. The Home Automation's Advantages

This section contains several important advantages related with Home Automation systems based on priority for our life reported in the literature and arranged into groups according on similar advantages see Figure. 2.

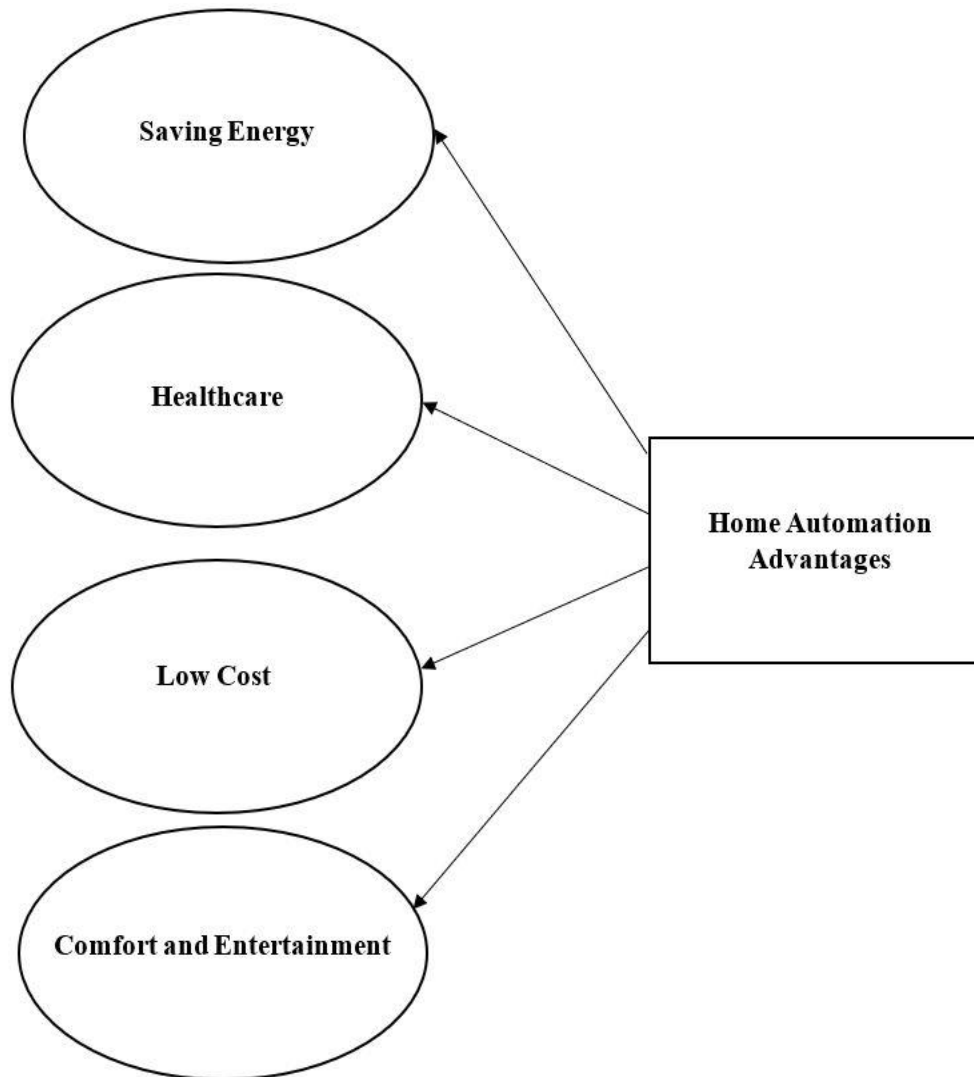

Figure. 2: Home Automation's advantages based on IoT.

1.3.1. Saving energy with Home Automation

Saving energy considered one of the most important features in Home Automation. Internet of Things (IoT) items in smart home has used to supply a technology (advance technology) to decrease losing the energy and control systems. These items have increased the efficiency and improved the power factor during saving energy [15]. For instance, automated light control is supplied by a light - system in a smart home, in this case the systems have automate ability to turn the lights on and off [16].

During the daylight, electricity of self-produced possible to be activated and turn on the devices. After the sunset, standby mode can be activated and turn off the devices automatically. As a result, this operation can be reduced the energy consumption [17].

Smart lights of the Internet of Things (IoT) items in smart home can be switched off and on automatically when someone gets in or out of the room or even the house to reduce the energy consumption [18].

Conservation the energy is an important problem. Inside or outside the house the temperature degrees are continuously changing, and the consumption of energy's amount can be raised at certain times. For instance, systems of air conditioner can be adjusted the medium inside the house and supplied comfortability for the environment with minimum energy consumption [19].

1.3.2. Healthcare with Home Automation

Smart home applications are also increased the benefits of home care for older people and the people who have disabilities. These homes are designed to look for these individuals' health and block the feeling of loneliness. A city has been established with smart home systems to support the older people with opportunities to provide suitable living, healthy, and successful, that call had been made by the government of north western Italy [20].

In smart homes, older people and people who have disabilities are helped and assisted to reach a healthy and long life by the robotic devices. Smart homes are also supported immediate clinical health care and enhanced reaching to medical services by monitoring the people's health from a distance, these services are usually not provided in ordinary homes. The needs of older people can be expected without any interference from human. Furthermore, the older people are checked if they take their prescribe medicine on-time, follow the treatments well or they do not [21].

Generally, in Japan, China, Europe, and the United States the older parents are living with their children, but the adult ones cannot always take care of older parents. The older parents who have no one to take care of them, the mobile smart home can provide enough help and a good life for them. The CCTV is used for monitoring the condition of an environment inside home by the medical staff via smart home [22].

1.3.3. Low cost with Home Automation

A lot of appliances are used in a smart home for the purpose of covering basic needs to save money by users. The access of older people and the people who have disabilities to health care have increased. At the same time, the cost of health care delivery is decreased by the health monitoring from a distance. Such as smart system, which is usually not exist in the clinics and hospitals, can decrease the cost and increase access to medical services. In smart home, wireless network technology is used instead of wires network to decrease the cost and increase fluently and flexibility. In addition, the energy conservation decreases the cost. Furthermore, failure of any appliances has avoided that cause energy conservation by the security system. Without avoiding that failure in devices, a confusion in the energy used will appear, that's led to a significant consumption of energy [23] [24]. By connecting the IoT devices in smart home with networks of healthcare, the frequency of visiting the doctor with older people or the people who have disabilities will be lower and also, reduce the cost medical [25].

1.3.4. Comfort and entertainment with Home Automation

The smart home supply a comfortable life to users and make sure the users is safe and secure. All the devices in the system of smart home can be worked at any time [26]. All of these appliances are supplied with sensors and every sensor has different function, connected through wireless based on IoT technology [27]. For instance, the appliances are used inside the smart home can automatically turn off, when the user goes out of their house. Also, the users can pay their bills conveniently with smart home. Smart home with mobile devices are suitable for users, and these mobile devices can be used to turn the devices on and off remotely instead of physical key [28].

1.4. Background and Motivation

In this thesis, the history, definition, and the use of the Home Automation (smart home) system. And also, the benefits of smart home have studied. More details and description of the latest systems that have built and electronic materials that have used in the Home Automation system can be founded in Chapter 2. Home safety has provided for dwellers by the Home Automation. The lights can be turned on automatically in compartments, stairs, and other dark places. Devices that have installed in the Home Automation consumes low energy. That's mean, it saves power. Thus, Home Automation technology is too suitable for the environment. Besides, the technology is keeping the mind in peace [2]. The major motivating factor behind this thesis is the Smart Home (Home Automation) system.

The aim of this thesis is to build a system based on Arduino Mega 2560 and connecting it with several sensors, components. And also, to control home items remotely by smart devices in addition to link the system with GSM network. The system should introduce flexibility and extensibility with low cost and low energy as possible as it can for users' needs with concern on easy using, reliability, and security.

1.5. Thesis Organization

This thesis contains of 4 chapters. All of the important information about Internet of Things (IoT) and Home Automation (Smart Home) can be founded here.

Chapter 1 is an introduction, a brief review of the history and the main definition of IoT (Internet of Things), review and benefits of Smart Home (Home Automation) all of these have been mentioned.

Chapter 2 is a literature review, describe the main components and materials that have been used to build the Home Automation system.

Chapter 3 is an implementation, shown how the smart home system has been built, developed, and combined the materials together and to describe the new Home Automation system.

Chapter 4, in this chapter the conclusion part and limitation of the system are described, and the future works are suggested.

CHAPTER 2

LITERATURE REVIEW

2.1. Previous Studies

Billure. R., Varun. M., Tayur. V. M., and Mahesh V., (2015): In this research, the authors show state of (IoT) security by investigating and classifying present direction in securing environments of IoT. Besides, challenges have opened as study case. The Internet has converted the world in diverse ways and also linked the modern devices to the Internet. The interconnection of the appliances has helped to improve people's living over both development and automation. All the communications, that have happened on the public networks, have wanted a secure channel of communication while, private information is transformed. Also, the authors in this research try to show the challenges in (IoT) that related to security [29].

Patru. I. I., Carabaş. M., and Barbulescu. M., (2016): In this paper, a concept's proof for easy adapting to a real home for a smart home system has been suggested by the authors. A small house has presented in this research and given a suggestion and solution for using a security mechanism that possible be controlled remotely. Furthermore, two smart devices' functionalities have been integrated to change the power magnitude of lights and room's temperature degree through a single interface. In addition, the mechanism of smart home (Home Automation), the communication between devices, has described and applied, and also the architecture of the application and deletes of applying the mentioned functionalities in this research. Moreover, the authors suggest a solution for connecting several appliances into a signal entity that can be used easily at any time. The functionalities of several Home Automation devices are integrated and implemented into a one application [30].

Manikandan J. (2016): In this research, a Home Automation system has designed by using deferent technologies and explained along with their functionalities and requirements. Also, the details about the hardware design for all the suggesting systems have been evaluated and discussed. Besides, smart industries, smart offices, smart homes, and many more systems that has huge potential are proposed in this paper. A various technology has considered in this research including the Ethernet-based, IR-based, Bluetooth-based, RF-based, GSM-based and voice-based Home-Automation systems. The above systems of Home-Automation that have mentioned, have their own advantages and disadvantages [31].

In addition to the analysis and conclusion of the previous cases that has been studied, the idea of using the Bluetooth and RFID devices is included in the system that has been designed in chapter three. Also, increasing the security of the Smart Home system has considered. These ideas have been taken from the first case. However, the idea of using and designing the mobile application. And from that application, the devices of Home Automation can be controlled and monitored. In addition to that, the idea of connecting and functioning all the items of Home Automation together at the same time has been provided. These suggestions have been taken from case study two. Finally, from the third case study, GSM module and Bluetooth also have been provided and included with a Home Automation system for controlling home devices. Furthermore, all the suggestions for solving and avoiding the problems for previous studies has been taken.

2.2. Arduino

Arduino is a physical processing and open source at the same time that's based on a microcontroller board and a united development for the board to be programmed. Arduino has a several inputs (for example; switches or/and sensors) and control a several multiple outputs (for example; lights, engine, and others). The program of Arduino can be worked on Windows, Macintosh, and Linux operating systems (OS).

Programming of Arduino is simple to learn and apply for everyone including the beginners. Arduino can be used to make interactive appliances, taking inputs from a different collection of switches or/and sensors, and to control a set of lights, engines, and other physical outputs. Arduino activities can be remained individually, or they can be connected to programs working on a specific device (e.g. Flash, Processing and Maxmsp.). The board can be gathered piece by piece by hand or buy pre-assembled. Also, the open-source IDE can be downloaded for free (free of charge) [32].

In Figure. 3 are shown the picture of the Logo of Arduino company.



Figure. 3: Arduino company logo [32].

Arduino board has built in the Ivrea Interaction Design Institute proposed for students who do not have a knowledge in programming and electronics concept. In the beginning, the Arduino board has started to get use to new demands and challenges. And changing from simple 8-bit boards to appliances that involved with applications of IoT (Internet of Things). Every Arduino board is entirely open-source, that means the users are allowed to design them separately and, in the end, Arduino should be adapted to their exact needs [32].

2.2.1. What is the Arduino board?

Arduino board is an open-source stage utilized to build electronics projects. Its content of two parts, a Microcontroller part and the software part or IDE (Integrated Development Environment). IDE functions on a PC that has used for writing and uploading the computer code to the physical Microcontroller. Unlike most of the other circuit board can be programmed; the Arduino does not need to disconnect a hardware parts for programming a new code and install it on board instead of that a USB cable can be satisfied for this purpose by making a connection directly. For the purpose of making the Arduino IDE simpler, the basic version of C++ is used to simplify the software. Finally, a standard form factor has offered for breaking out the Microcontroller's functions into several extra packages [32].

2.2.2. Why Arduino boards

For making different projects and applications of engineering, Arduino boards have utilized. The software of Arduino is quite simple for beginners and also flexible enough for professionals. The software of Arduino is compatible with Windows, Linux, and Mac OS.

In the term of the cost, Arduino boards are quite cheap comparing to other Microcontroller's boards. The version of the Arduino module that has lowest expensive can be assembled by hand, while the Arduino module of pre-assembled can cost approximately fifty dollars.

The Arduino software has been released as open-source tools, and also available to be extended by programmers who have experience. The language of software can be extended by C++ libraries, and the people's seeking is to understand the details how to improve from Arduino to advance language programming.

The ideas of Arduino boards are published under a Creative Commons license, is to give the opportunity for designers to build a version that they are looking for with improvement and extending it. Even the user how doesn't have more knowledge can build their own version for the purpose of understanding how the board works and saving money [32].

2.3. Arduino UNO R3

To initiate an Arduino, the UNO is a huge choice to select. This Arduino (UNO) has a 14-digital Input and Output pins, where 6-pins can be utilized as PWM (pulse width modulation outputs), a power jack, a reset button, a USB connection, 6-analog inputs, and other things. UNO Arduino has all the needs that required to support the Microcontroller; easily connect it to a PC via a USB cable. And that UNO Arduino can be given the power to start by AC-to-DC adapter or battery [32].

In Figure. 4 are shown the picture of Arduino UNO R3 board.



Figure. 4: Arduino UNO R3 board [32].

2.4. Arduino Mega 2560

The Arduino Mega is alike to the Arduino UNO with more features. Arduino Mega has too many of digital Input/Output pins (start from, 14-pins can be utilized as PWM O/PS), 6-analog inputs, a reset button, a power jack, a USB connection. The big number of pins make the Arduino Mega board very powerful for building the projects that seek for a lot of digital I/PS or I/PS like more buttons [32].

In Figure. 5 are shown the picture of Arduino Mega 2560 board.

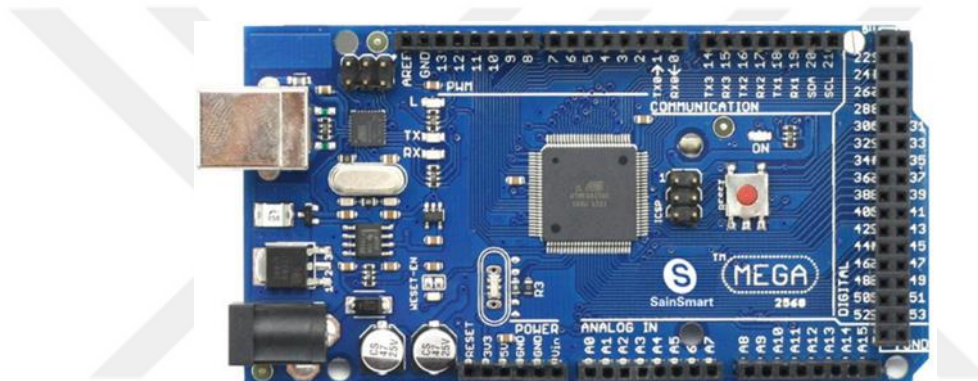

Figure. 5: Arduino Mega 2560 board [32].

2.5. Arduino Shields

The Arduino shields are considered as pre-design circuit boards that utilized to link the Arduino boards with appliances. The Arduino shields stick on the top of the Arduino compatible boards to support an extra capability such as connecting to the internet, providing wireless communication, LCD screen controlling, motor controlling, etc...

The kinds of an Arduino shields are:

- Ethernet Shield.
- GSM Shield 2.
- Wi-Fi Shield 101.
- Wi-Fi Shield.
- Wireless SD Shield... [32].

In Figure. 6 are shown the picture of Arduino Ethernet shield.

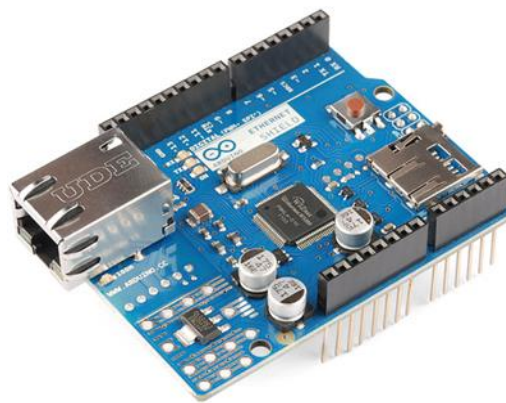

Figure. 6: Arduino Ethernet shield [32].

2.6. Arduino Programming Environment IDE

The Arduino Software or Arduino Integrated Development Environment (IDE) has a text editor for writing code, a message area, a text console, a toolbar with buttons for common functions and a series of menus. The Arduino Software (IDE) is supposed to be connected to the Arduino hardware to upload codes (programs) and to link between each other [32].

In Figure. 7 are shown the picture of Arduino software IDE.



The screenshot displays the Arduino IDE interface. The main window title is "Blink | Arduino 1.8.5". The code editor shows the following code:

```
pin the on-board LED is connected to on your Arduino model, check
the documentation at http://www.arduino.cc

This example code is in the public domain.

modified 8 May 2014
by Scott Fitzgerald
*/

// the setup function runs once when you press reset or power the board
void setup() {
  // initialize digital pin 13 as an output.
  pinMode(13, OUTPUT);
}

// the loop function runs over and over again forever
void loop() {
  digitalWrite(13, HIGH); // turn the LED on (HIGH is the voltage level)
  delay(1000);            // wait for a second
  digitalWrite(13, LOW);  // turn the LED off by making the voltage LOW
  delay(1000);            // wait for a second
}
```

Below the code editor, the console shows the upload status:

```
Done uploading.
32,256 bytes.
Global variables use 9 bytes (0%) of dynamic memory, leaving 2,039
bytes for local variables. Maximum is 2,048 bytes.
```

The status bar at the bottom indicates "Arduino Uno on /dev/cu.usbmodem1411".

Figure. 7: Arduino software IDE [32].

2.7. Sensors

A sensor is an item that detects and responds to several types of input from the physical things in our life. The sensor's input possible to be light, heat, motion, humidity, pressure, or any one of a huge number of other phenomena of the environment. The output of sensor is usually a signal that is changed to be readable for human and display at the sensor location or sent a signal over a network for controlling or other tasking.

2.7.1. RFID sensor

RFID (Radio-Frequency Identification) support simple, low power, and many with several options for identity and access points. RFID technology are utilized two methods radio TX (transmitter) and RX (receiver) to determine and tracking marks that get engaged with objects [33].

In Figure. 8 are shown the picture of RFID-RC522 sensor.



Figure. 8: RFID-RC522 sensor.

2.7.2. Gas sensors

The M-Q6 series of gas sensors are used with a small heater inside that named as electrochemical sensor. The sensitivity of these sensors has limited range of gasses and utilized indoors only. The output of this sensor is an analog readable signal that can be read by an analog input of the Arduino.

In Figure. 9 are shown the picture of Gas sensor type MQ-6.

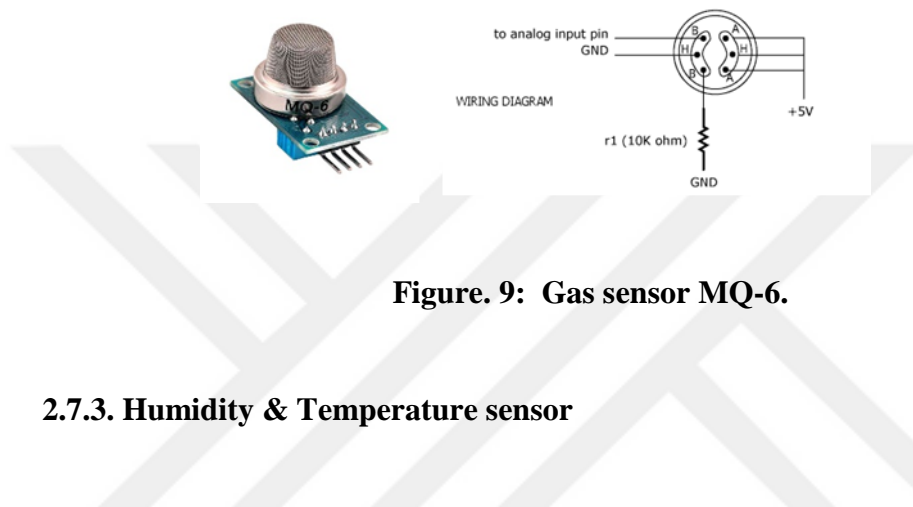

Figure. 9: Gas sensor MQ-6.

2.7.3. Humidity & Temperature sensor

The DHT22 sensor is a low cost and energy digital temperature and humidity sensor. This sensor uses a capacitive humidity sensor and a thermistor to measure the environment and transmit a digital signal on the data pin (it can be connected to digital or analog pins). It's quite simple to use but requires carefully with the time that need to collect data.

In Figure. 10 are shown the picture of Humidity & Temperature Sensor type DHT22.

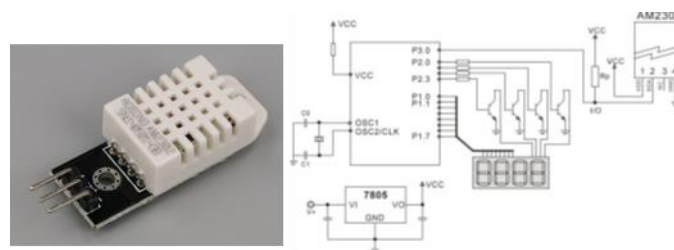

Figure. 10: Humidity & Temperature sensor DHT22.

2.7.4. Motion sensor PIR

The PIR sensor (motion sensor) is designed to detect movement. PIR known as Passive Infrared. In addition, the purpose of the PIR motion sensor is to measure infrared light from bodies in the area of vision. The sensor detects a motion based on changes in infrared light in the environment. At the sensor's range, the sensor's function is to detect the movement of the human when it goes inside and outside. The sensor is designed into two parts of potentiometer, the first part is the left side to adjust the delay time, while the second part is the right side to measure the sensitivity.

In Figure. 11 are shown the picture of Motion sensor PIR type HC-RS501.

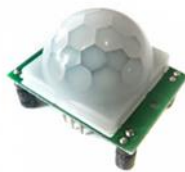

Figure. 11: Motion sensor PIR HC-RS501.

2.7.5. Flame sensor

The flame sensor module work on detecting the flame, and also has a sensitivity to ordinary light, for this reason the sensor is usually utilized as flame alarm. The sensor can detect only a flame or a light that has a wavelength in the range from 760nm to 1100nm with an angle of 60 degrees.

In Figure. 12 are shown the picture of Flame sensor are used for Arduino.



Figure. 12: Flame sensor for Arduino.

2.7.6. Reed Switch sensor

The Reed Switch sensor is a type of passive electronic switch, that communicates to a simple structure, easy to control and small size. Furthermore, this sensor is a device of circuit switching that has controlled by a signal of magnetic field. Also, the Reed switch sensor can be utilized to limit and count a specific area, etc... (can used also in the security systems, mainly utilized to protect the doors and windows).

In Figure. 13 are shown the picture of Reed Switch sensor are used for Arduino.



Figure. 13: Reed Switch sensor for Arduino.

2.8. Keypad 4x4

A keypad is one of the most widely utilized input tool with microcontroller applications. In ordinary keypad that designed as an X-Y switch matrix, generally open switches are linked to a row and a column when one of buttons be pressed.

In Figure. 14 are shown the picture of Keypad 4x4 are used for Arduino.



Figure. 14: Keypad for Arduino 4x4.

2.9. Servo Motor

The ordinary term of the servo motor is a standalone electric motor, that works on pushing and rotating parts in the item (servo motor) during a specific task and position that need to be done and defined. When a servo motor is given an order, a specific part of the motor will be moved to a specific position and holds there until a new task given. A servo motor is used either a rotation or a linearly move to control an angle or linear position through velocity and acceleration. The function of servo motor normally needs power between 4.5V–6V, ground, and wires for controlling.

In Figure. 15 are shown the picture of Servo Motor are used for Arduino.



Figure. 15: Servo Motor for Arduino.

2.10. Relay

Normally, relays are mechanically functioned as switch utilizing an electromagnet, while these kinds of relays are called as solid-state relay. There are several kinds of relays that classified based on different criteria such as based on operating voltage, based on operating technology, and etc...

In Figure. 16 And Figure.17 are shown the picture of two type of relay.

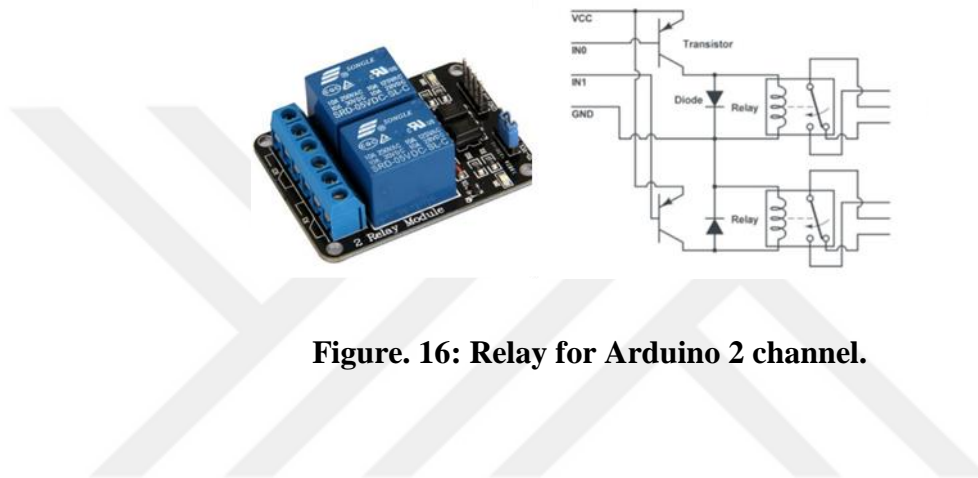

Figure. 16: Relay for Arduino 2 channel.

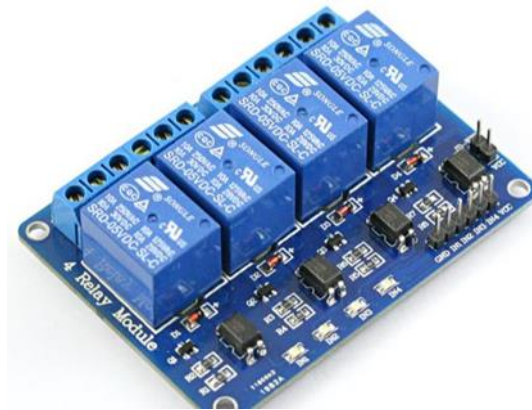

Figure. 17: Relay for Arduino 4 channel.

2.11. Buzzer

Buzzer module is a suitable thing to add a tone alarm or notification to your Arduino system. Note that, a buzzer is operated by supporting with an oscillating signal. The notes and tunes can be changed or created by the tone () function in the Arduino. The Voltage that makes the buzzer work is between 3.3-5V.

In Figure.18 and Figure. 19 are shown the shape of two types of buzzer.



Figure. 18: Regular Buzzer for Arduino.



Figure. 19: Passive Buzzer for Arduino.

2.12. LCD 16x2

LCD (Liquid Crystal Display) screen is an electronic display component that can be used with a wide range of uses. One of the common screen that is used in different circuits and devices and also very basic module is a 16x2 LCD display.

In Figure. 20 are shown the picture of LCD 16x2.



Figure. 20: LCD 16x2 for Arduino.

2.13. I2C LCD Expansion

I2C Interface Board is normally an Input/Output expander board that minimized the usage pins number (Input/Output) with the Microcontroller Arduino. This I2C module, sticks to the back of an LCD Module, and because of this expansion board it is possible to use only two pins (SDA and SCL) to the LCD modules.

In Figure. 21 are shown the picture of Expansion for Arduino LCD.



Figure. 21: I2C expansion for Arduino LCD.

2.14. Low-Energy Bluetooth

This technology is using a low-energy, and also longtime processing for the needs of (IoT) operating, while fully utilizing a typical technology with native support during the system's work [34].

In Figure. 22 are shown the picture of Bluetooth type HC-06.



Figure. 22: Bluetooth HC-06/ZS-040 Device.

2.15. RGB LED

RGB LED module is designed for a patch full color by R, G, B. These three pins of the PWM input voltage can be controlled and adjusted in three main colors (Red, Blue, and Green) intensity in order to reach and combine fully color effect.

In Figure. 23 are shown the picture of RGB LED.



Figure. 23: RGB LED for Arduino.

2.16. SIM800L

The SIM800L device is a Mini GPRS/GSM advance module that supports quad-band GPRS/GSM network. And also, this device supports for GPRS and SMS message data remote transmission. The features of SIM800L device have a compact size and low energy consumption.

In Figure. 24 are shown the picture of Sim800L GSM.



Figure. 24: Sim800L GSM for Arduino.

2.17. MIT APP INVENTOR 2

The MIT App-Inventor 2 web application is considered as open source web application. This web application content of the two parts to build android application. The designer part is the first part that has been customized to design the GUI of android application. The tools of this part can be located by “Drag” and “Drop” method onto the screen supported. The Blocks Editor is the second part of the App-Inventor 2 web application that is used to describe the suitable behavior of the designer part (First part) that has been programmed [35].



CHAPTER 3

IMPLEMENTATION

In this thesis the Home Automation system has been designed and implemented in two major parts and every part is a separated system based on Arduino Mega 2560 Microcontroller.

In power supplying section, UPS has been used (Uninterruptible Power Supply) to make sure that the system is still working under any problem related to electricity from outside of the home (for example, cutting the main cable that supply the home by electricity) and avoiding any failure on the system or shut it down accidentally or on purpose.

3.1.Front Door Security System (FDSS)

3.1.1. System description

The purpose of designing this system is to secure the front door that called FDSS (Front Door Security System). The FDSS system has two types of authorizations entry; the first type of authorization entry has a technique called RFID (Radio Frequency Identification) sensor, while the second type of authorization entry has a Keypad with 4x4 buttons that used to enter password. And also, the system has two types of lock setup on the front door; the first one has a Servo-motor while the electric lock (the second one) is connected to a relay for controlling the lock. Furthermore, the system has a PIR sensor, PIR sensor is connected to a relay for the purpose of turn on the light automatically in front of the home's door. In addition to that, the system also has a push button to open the front door from inside.

The relay that is used in the FDSS system contents of two channels; first channel is connected to a light and the second channel is connected to the electric lock. Finally, the system also has several other components such as; LCD 16x2 screen, RGB led, and Buzzer device to monitor and control the system.

According to amazon store all components and materials cost approximately less than 100\$ American dollars. In Figure. 25 The block diagram of the FDSS system (Front Door Security System) giving more details and explain how the connection of the Microcontroller (Arduino Mega 2560) with sensors and input/output components has designed. In Figure. 26 and Figure. 27 see how all components and materials of the system have been connected.

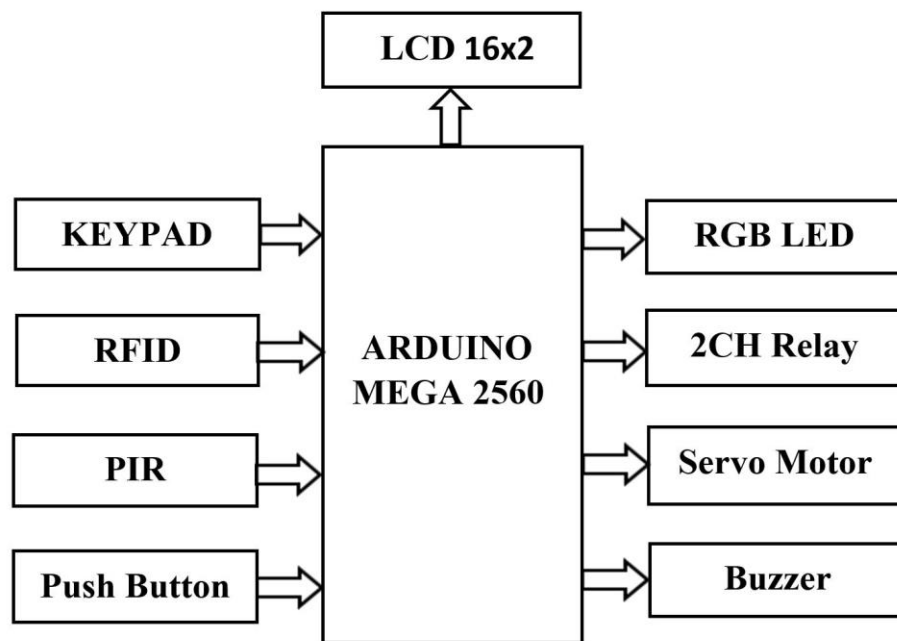

Figure. 25: Block diagram for Front Door Security System (FDSS).

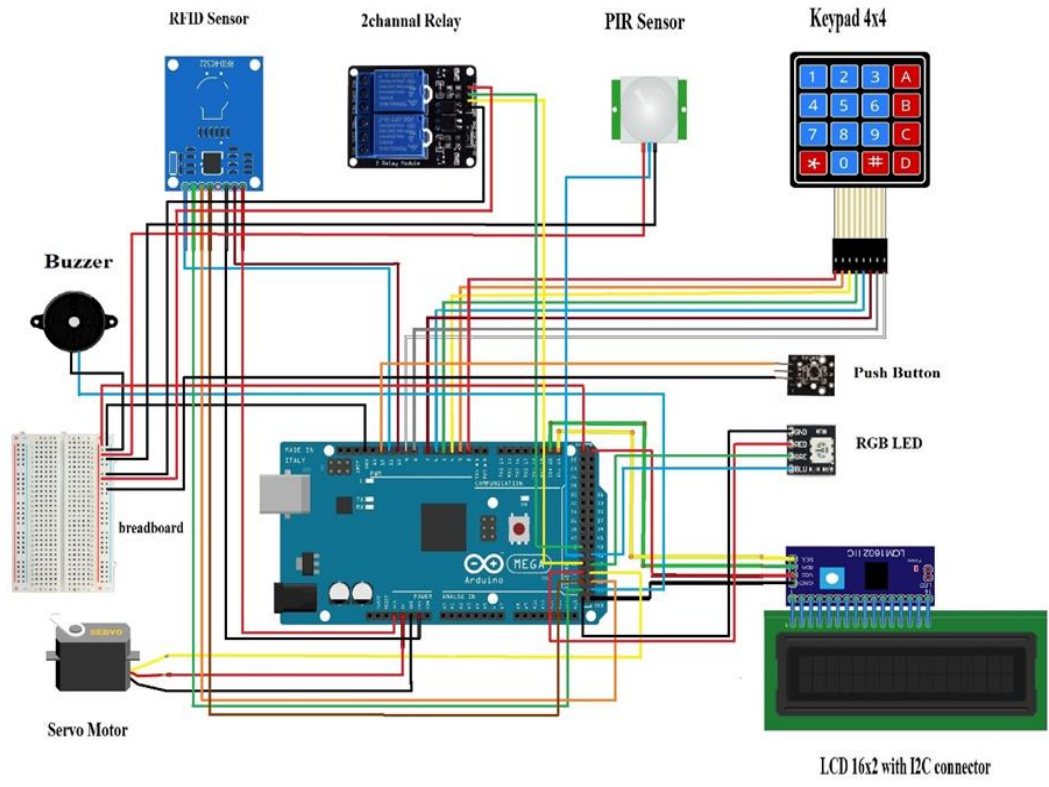

Figure. 26: Front Door Security System (FDSS) architecture.

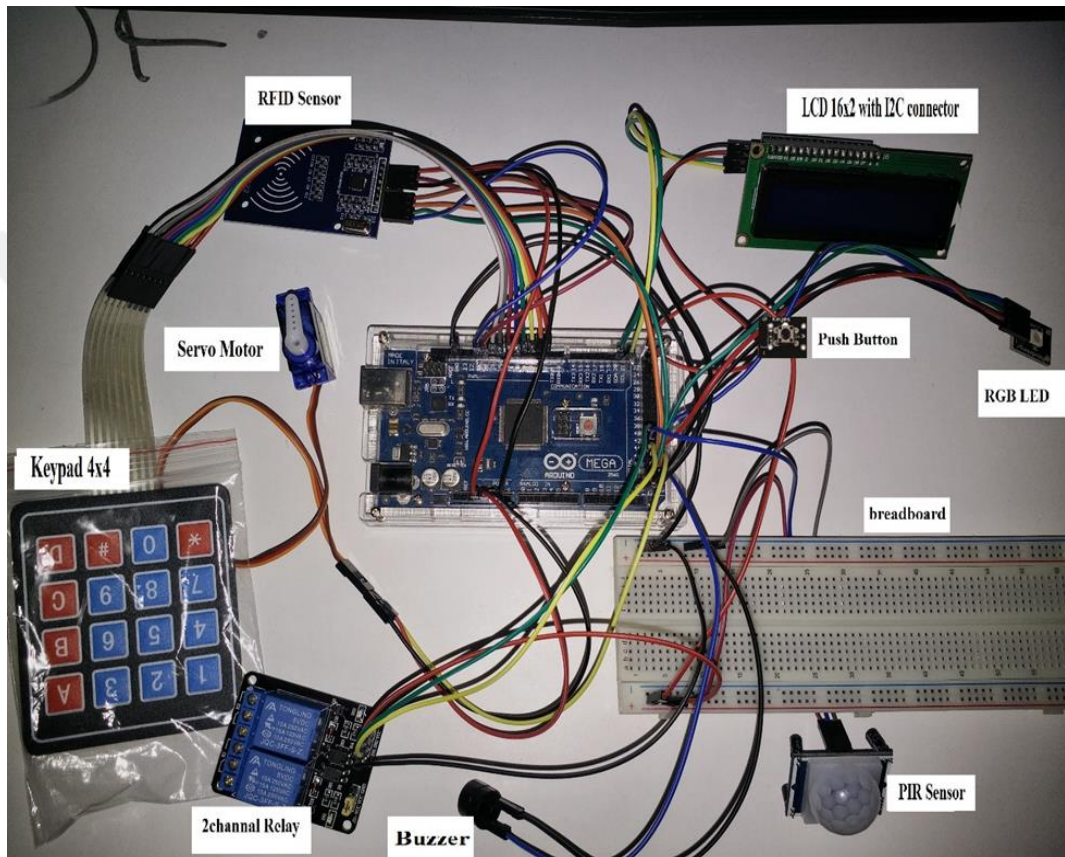

Figure. 27: Front Door Security System (FDSS) real components.

3.1.2. How Front Door Security System (FDSS) works

FDSS system is designed to be secure, open, and close the lock of the home's front door. In the beginning, when someone stands in front of the door (from outside), the PIR sensor should be detected a motion and sent the signals to the microcontroller. After that, the light will be automatically on by the instruction from microcontroller through the relay for a limited time. And that will be the first operation of the system. The first method to unlock the door is by using an RFID sensor with a unique card. If ok (matching card ID) the door will be unlocked for a limited time and displayed on LCD screen "Authorized Accesses". Else if not ok (not matching card ID), in that case the door will be still locked and displayed on LCD screen "Access Denied".

The second method is by using a password, when someone press button "A" on a Keypad it allows him to enter a password and that password should be content of 4-digit numbers. If the password is correct, the door will be unlocked for a limited time and displayed on LCD screen "Correct Password / Door is Open". While in case of entering the wrong password, the door should be still locked and blinked red led.

These pervious two methods are to unlock the door from outside, while the third method is designed to unlock the front door from inside the home by using Push button.

Microcontroller (Arduino Mega) are connected to the items of the previous three methods from one side and to Servo-motor and relay form the other side for the purpose of unlocking and locking the front door of the home.

The password of the FDSS system can be changed. When a user is seeking for changing the password of FDSS system, first, the "A" button should be pressed on Keypad for the purpose of entering the password than directly the "C" button should also be pressed to change the password. After that, the old password will be asked. If the old password is correct, then "Enter new password" will be displayed on LCD screen. Else if the password has entered wrong, "Password is Wrong" should be displayed and returned to the previous step ("Enter new password"). After entering

the correct old password, the new password should be written plus “*”. To confirm the new password, “One More Time” will be displayed on the LCD screen and asked to enter the new password again to avoid any mistake with the new password.

In order to make the FDSS system work in a appropriate way, all the items such as; RFID sensor, Keypad, Relay, Push button, PIR sensor, LCD 16x2 screen, RGB led, Servo-motor, and Buzzer device are connected with each other though Arduino Mega 2560 Microcontroller and programmed with a C and C++ programming language for Arduino as shown in Figure. 26 and Figure. 27.

In Figure. 28 shows how, the system works exactly and explain in a flow chart.

3.1.3. Most challenges that fixed in Front Door Security System (FDSS)

The most challenges that have been fixed for building this system is to make all sensors and components work together in parallel way at the same time by using (Arduino Mega).

The most problematic section that has to be fixed is the part of writing the code and programming the system to make all sensors and components work perfectly and identically way at the same time by using many functions like “Millis () function”.

The cost also has been fixed and managed by using modern components and sensors from one side and balancing the cost with quality from the other side to build this system.

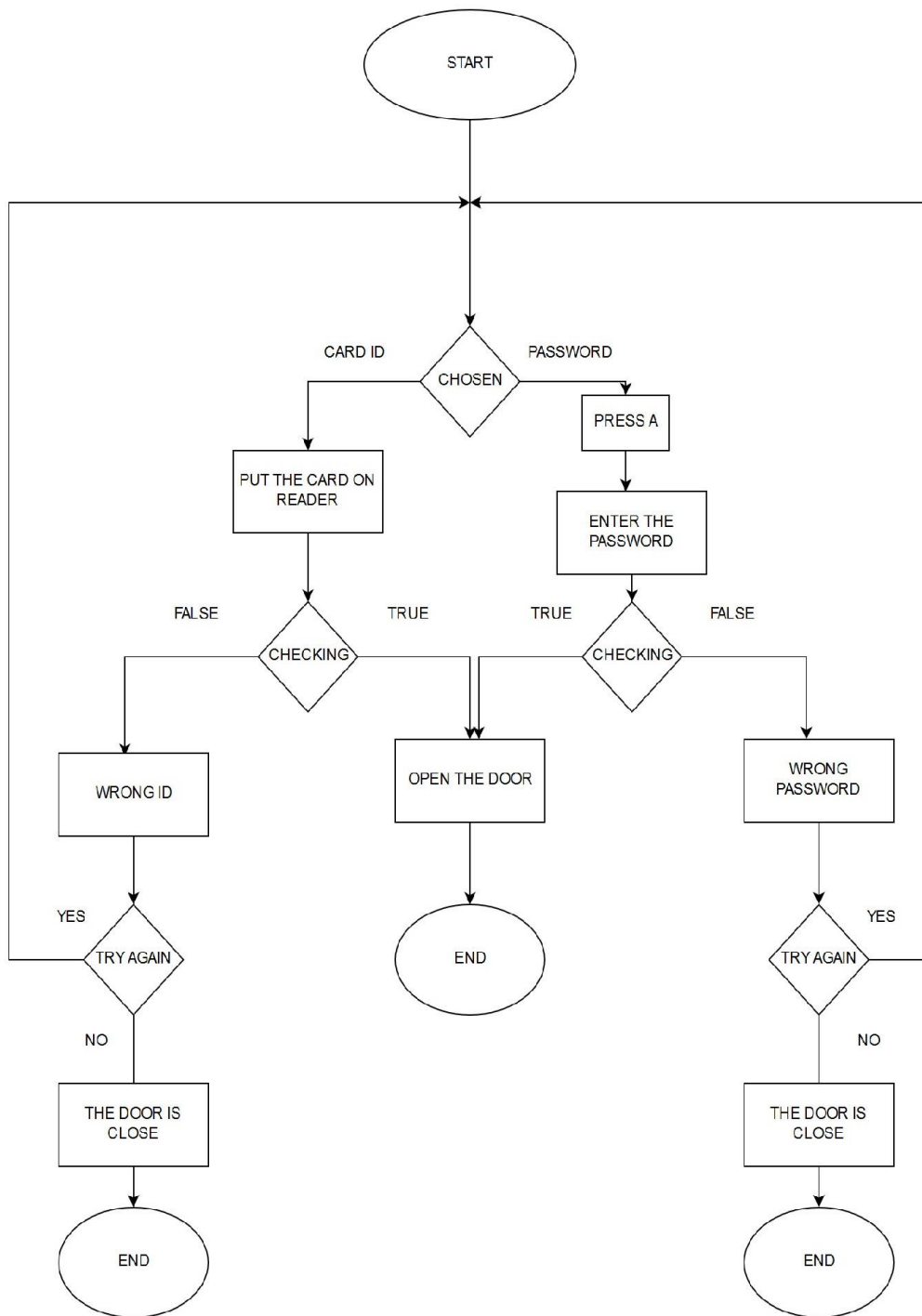

Figure. 28: Front Door Security System (FDSS) flow chart.

3.2. System Alarm and Control Unit (SACU)

3.2.1. System description

The SACU system has built and improved to secure and control inside section of the home by using several types of sensors and components based on Arduino Mega 2560 via Bluetooth and GSM network (Global System for Mobile communications) connection.

The main purpose of this system is to detect and warn if there is a fire (by using flame sensor), gas leaking (by using gas sensor), any unauthorized motion (by using a motion sensor and Reed-switch to protect doors or windows) and to send an SMS message to specific destinations (mobile numbers) to inform about any unnormal situation inside the home.

This system has keypad 4x4 to active the system in a specific time and deactivate the alarm with a password that contain of 4-digit number. Also, the humidity and temperature degree for the environment inside the home can be displayed on the LCD screen via a physical sensor. Furthermore, the SACU system uses Bluetooth connection technology to connect with android devices (Mobile, Tablet and etc..). By using android application, it's possible to control the electric devices (Such as; Light bulb, Fan, TV and etc..) and turn on/off these appliances remotely.

And also, the system has an LCD screen type 16x2, RGB LED and passive Buzzer device for monitoring and controlling the system. With these items, the interaction between users and the system should be easy and simple. The cost of SACU system according to amazon store approximately 110\$ American Dollars.

In Figure. 29 the block diagram of the system has given more details and explained how the connections between the Microcontroller (Arduino Mega 2560), sensors, and input/output components.

In Figure. 30 and Figure. 31 are shown the connections of all components and sensors in the ideal SACU system and real component of SACU system.

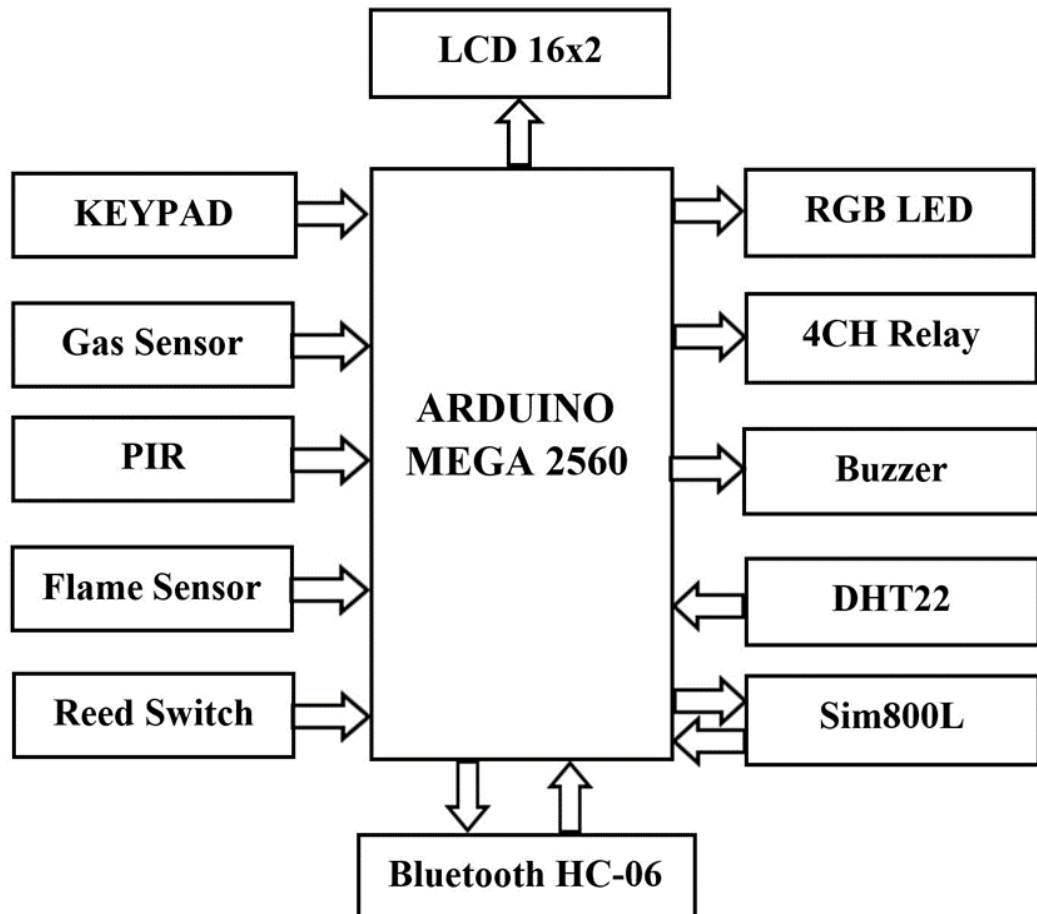

Figure. 29: Block diagram for System Alarm and Control Unit (SACU).

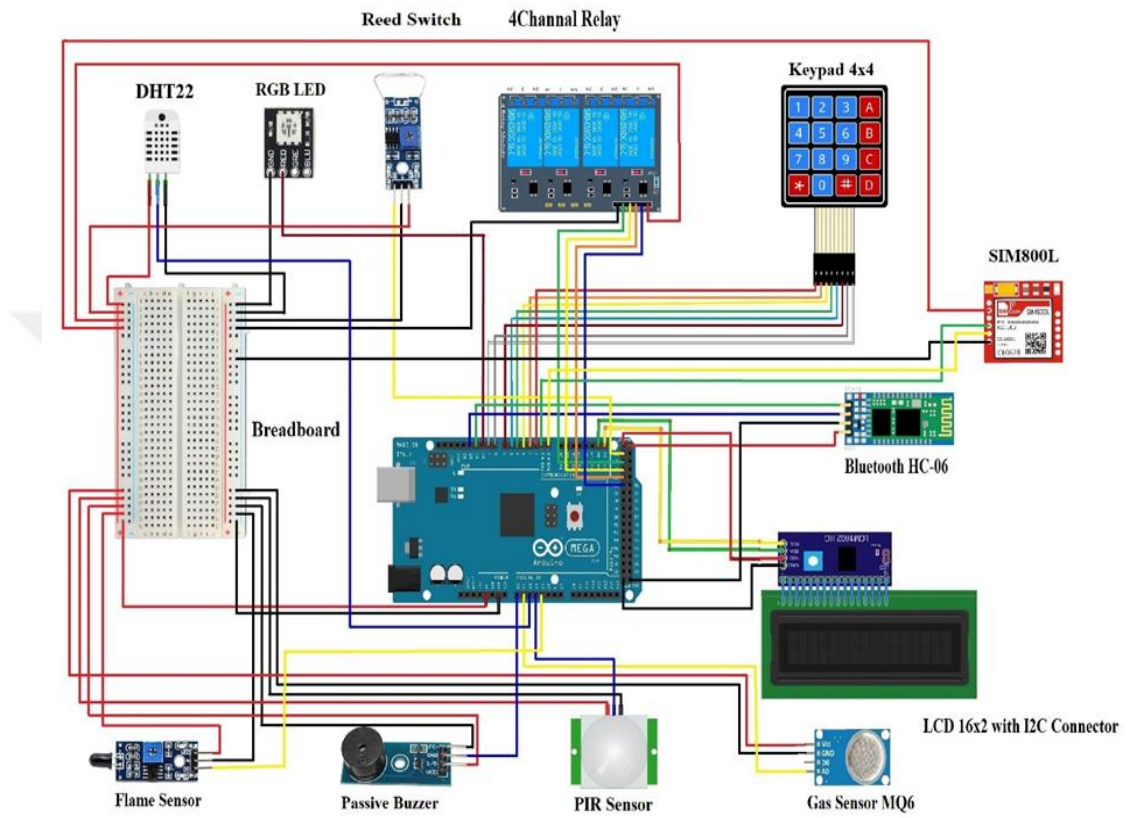

Figure. 30: System Alarm and Control Unit (SACU) architecture.

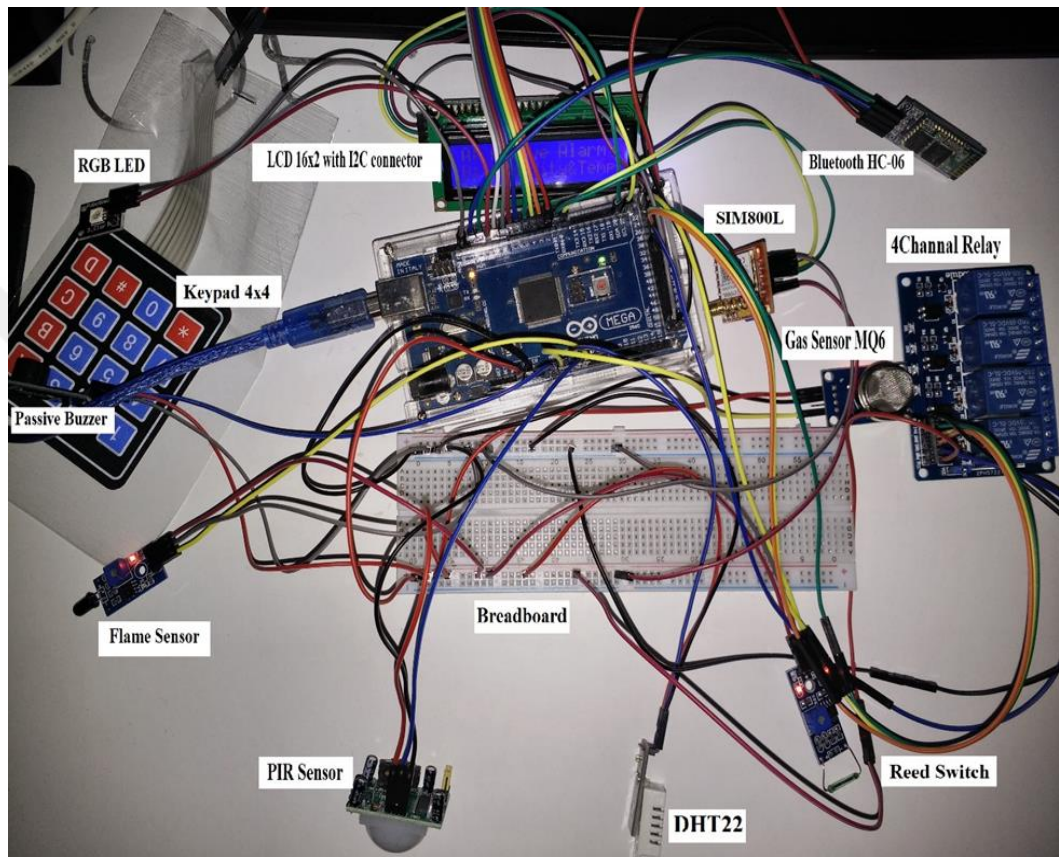

Figure. 31: System Alarm and Control Unit (SACU) real components.

3.2.2. How System Alarm and Control Unit (SACU) works

The main purpose of designing and building the SACU system is to monitor and guard the internal environment of the home. The SACU system has several types of sensor work with each other at the same time to make the system more functional. The system has been designed with two types of mode (idle mode and active mode) to work. The first mode is named the idle mode. When the system turns on, the system will be directly entered to idle mode. Some sensors in idle mode are kept working without activating the system alarm. Furthermore, in this mode the flame sensor, gas sensor, and humidity & temperature sensor should be kept working and ready for any detecting. The second mode is called the active mode when the “A” button be pressed on the Keypad; the system alarm will be activated after a specific time. Also, the SACU system can be deactivated the system alarm by pressing “D” button on a Keypad and writing the password. For information, this password should be contented of 4-digit number. In this mode (active mode) all sensors and components have worked together at the same time. In addition, in the SACU system, the mode can be changed from active mode to idle mode by pressing “D” button to deactivate the system alarm and 4-digit number password.

While pressing “B” button on the Keypad, the system should be displayed the humidity & temperature degree for the environment inside the home on the LCD screen via physical sensor (DHT22).

The password of SACU system can be changed by pressing “C” button on the Keypad. The LCD screen should be displayed “Old Password” to ask for entering the current password.

When the current password be entered wrongly, the main menu of the system must be shown directly on the LCD screen. On the other side, if the password be entered correctly, the system should be asked to enter the new password and displayed on LCD screen “New Password”. After that, when the new password be entered, the system returns to the main menu (when the new password accepted).

In this part, a timer has been used to quit from changing the password's operation and returned to the main menu of the system. The purpose of using a timer is to avoid any hang or delay in the system and ensure of working the system in a right way.

In the SACU system, the light-bulbs and fans inside the home can be controlled remotely (turning them On / Off) by using android application via a Bluetooth connection. And also, the light-bulbs and fans are linked to a Microcontroller through a relay device. While, this relay device has four channels, each two channels are linked to a specific room inside the home (2 channels for living room and 2 channels for bedroom). For more information, each channel has linked to one device. The GSM network system has been connected to the SACU system for the purpose of sending a warning SMS message to specific destinations (mobile numbers), when unnormal situation are detected by the sensors of the system (Flame sensor, Gas sensor, PIR sensor, and Reed Switch sensor). To do this operation, a SIM800L device has connected to the Microcontroller (Arduino Mega) in the SACU system. Figure. 32 is shown flow chart of SACU system and to clarify and simplify the understanding of system's working.

3.2.3. Most challenges that fixed in System Alarm and Control Unit (SACU)

Microcontroller (Arduino Mega) are used in the SACU system to contain and manage several types of sensors and components together (parallelly). And also, this type of Microcontroller can be worked with a satisfy number of sensors and components at the same time. In this way, the system should have functioned in an effective way.

In the coding part which is the hardest part of building and programming the SACU system. Besides, all of the obstacles and problems have been solved by writing the system's code in a specific way to ensure that all sensors and components are worked at the same time (parallelly and synchronously) in a right way. In a result, the sensors and components should be worked with maximum ability that makes the system work with perfect way.

The SACU system has been designed to detect and notify if there is a broken-down (failure) sensor or a problem with the connection and insure these sensors are working in a right way. This feature has been made in a code that insert to the system. For example, if the gas sensor failed in functioning for any reason, the system will give a warning of “gas leak” on the display screen and send SMS to a specific destination at the same moment of activating the alarm mode.

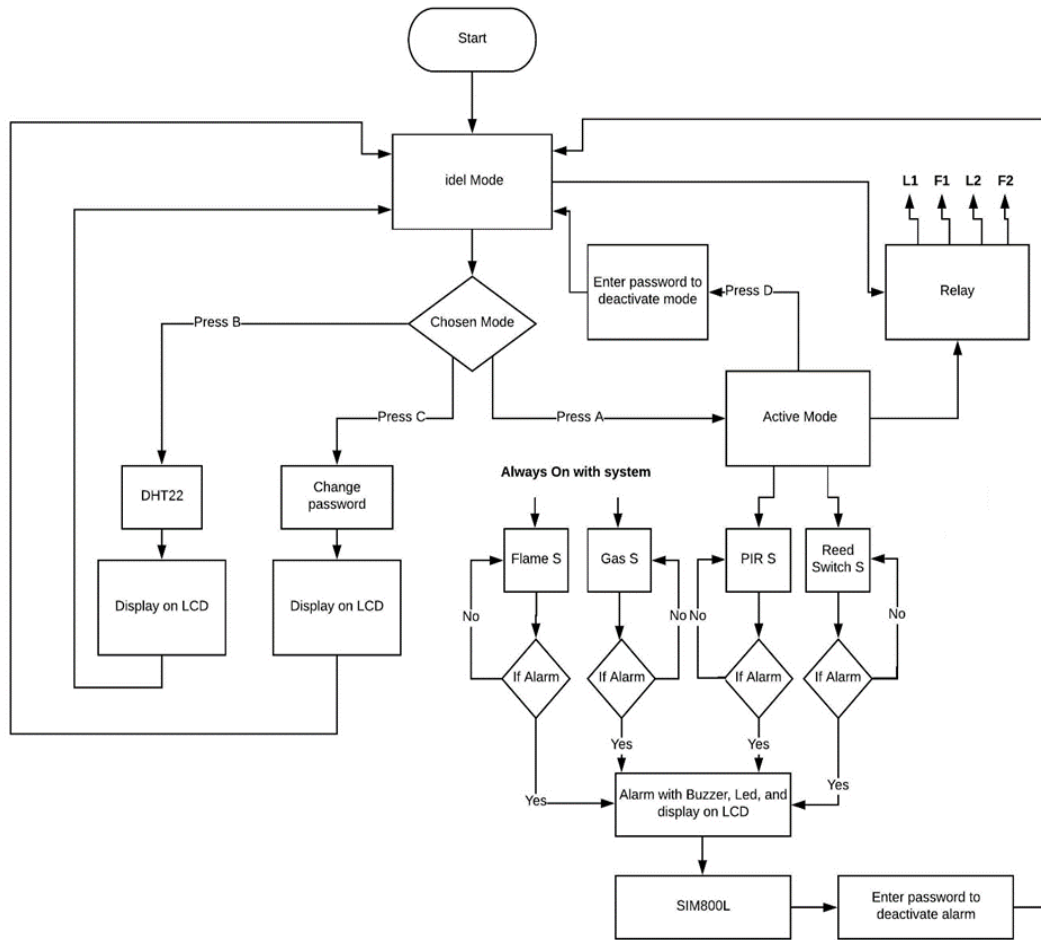

Figure. 32: System Alarm and Control Unit (SACU) flow chart.

3.3.Home Automation Android Application

3.3.1. Application description

Home Automation android application has been designed to control the electric devices (Such as Light-bulb and Fan) via Bluetooth connection. This application has been built by “MIT app inventor 2” application. Also, the application has designed to be easy and simple for the users by simplifying the GUI (Graphical User Interface). The application has one expression (“Bluetooth” Button) for a Bluetooth connection and can be shown the condition of Bluetooth if it’s “connected” or “not connected”. Furthermore, In the main page of the application, the screen has been divided horizontally into two sections: first one (upper side) for the “living room” and second one (lower side) for “bedroom”. Each section has 4 buttons, and each 2 buttons have designed for a specific device (first button for “on” and the other for “off”). The electrical devices can be managed and controlled all of them at the same time (by turn them on / off) by the Home Automation android application. The GUI design, block code, and the main page of the application can be shown in Figure. 34, Figure. 35, And Figure. 36.

3.3.2. How Home Automation Android application works

The main purpose of Home Automation android application is to control the light-bulbs and fans in the living room and bedroom. The first step should be made a Bluetooth connection to any smart device that use android operator. By pressing on the “Bluetooth” icon and choosing the name of the Bluetooth in the system which named “SmartHomeBT”, after that the password should be entered. For living room and bedroom, the lights and fans can be turned on / off by pressing on icon of the buttons which can be founded on the main page of the application.

When pressing on the buttons, the application should have sent specific text word through Bluetooth to the main system, to give specific orders, and to turn on or off these devices. For example, if light button has been pressed “on” for living room to

turn on the light, the application will send a text word (ON1) to the main system and give the order to turn the light on.

In Figure. 33 the flow chart of the application is shown and explained for the purpose of how the application work.

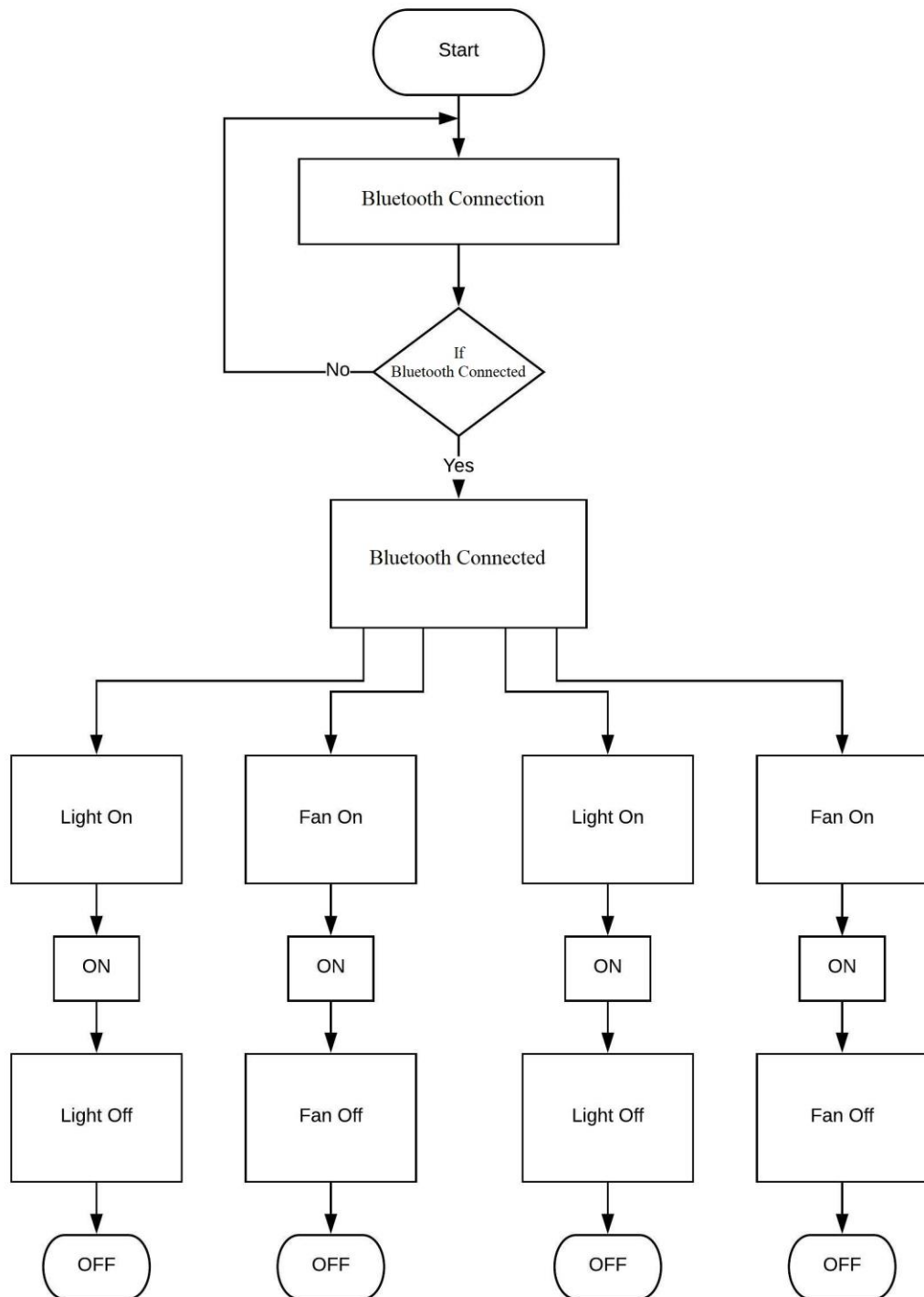

Figure. 33: Home Automation application flow chart.

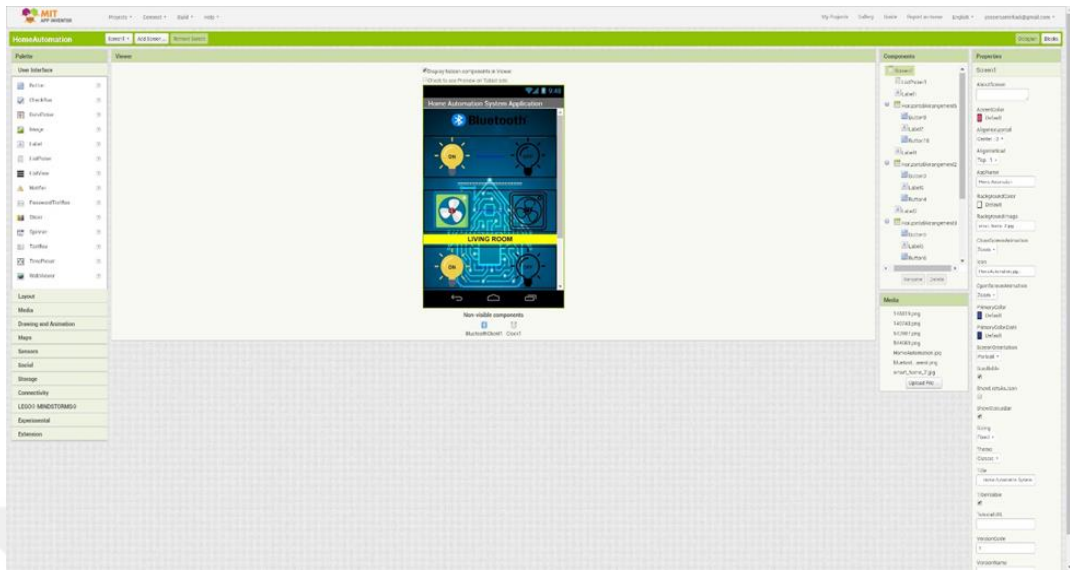

Figure. 34: Home Automation android application GUI design.

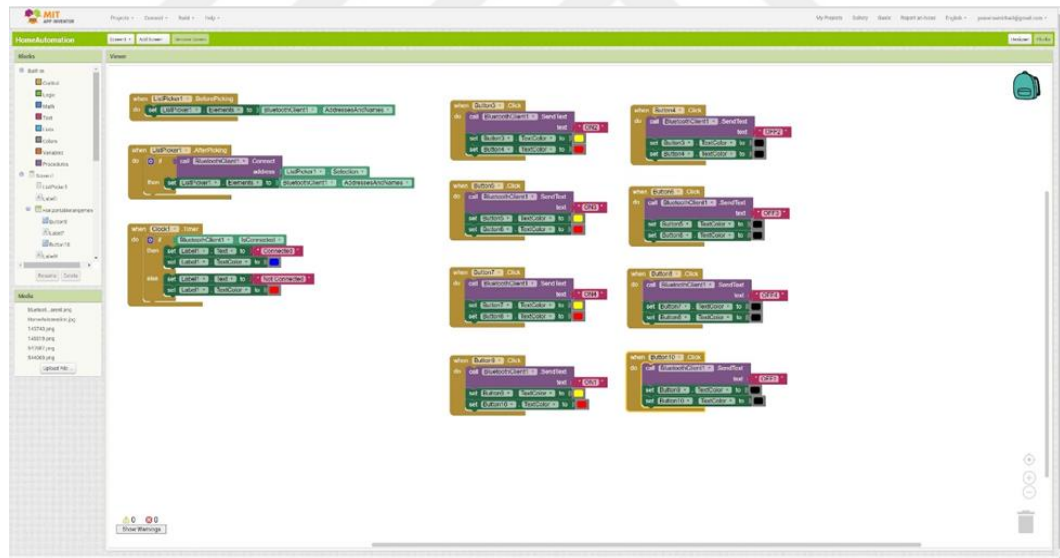

Figure. 35: Home Automation android application block code.

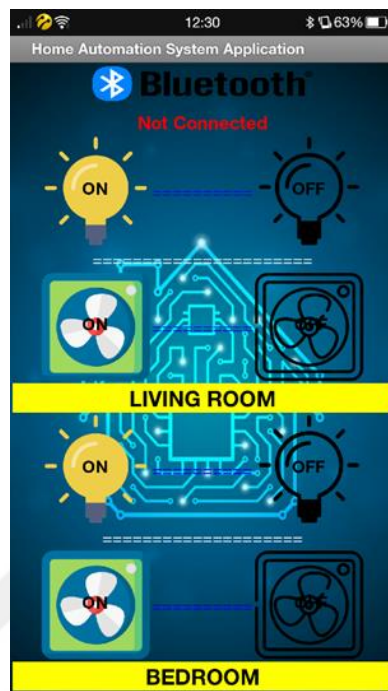

Figure. 36: The main page of Home Automation application.

3.4. Novelty and Comparison with other Similar Systems

The TEPE or PRONET Home Alarm Systems have been designed with Burglar alarm, Fire alarm, Gas alarm, Flood alarm, and Medical Panic alarm. The system's work is activated when there is a condition or sensors detect something such as a burglary attempt, panic, fire, gas leak, flood or in case of a medical interference is required, the Alarm Monitoring Centre is receiving a signal through the sensors or detectors and/or Medical Panic buttons in the customers home. TEPE or PRONET Alarm Monitoring Centre employees directly call the house owner to define and locate the problem and to act accordingly. After knowing the situation, law enforcement, fire service, police and medical units are been called to go directly to the house address without losing any time. TEPE and PRONET Alarm Monitoring Centre end the alarm status by giving feedback from specific units guided by the employees [36] [37].

The novelty of FDSS and SACU systems is to design a system alarm and to automate the devices inside the home via Bluetooth connection and also to include a GSM module to send warning message SMS contents type of the detection from sensors. Besides, these systems are used RFID to access to home in addition to a password which are included. The TEPE and PRONET Home Alarm Systems has not used a Bluetooth connection for controlling the devices (Lights and Fans) or GSM module, while Monitoring Center is used to notify in case of any detection from sensors and definitely most pay monthly amount of money for these services. The TEPE and PRONET Home Alarm Systems have two more features like Flood sensor and Panic alarm and these features is not included in FDSS and SACU systems.

CHAPTER 4

CONCLUSION, LIMITATION AND FUTURE WORK

4.1. Conclusion

Smart Home (Home Automation) with IoT devices has become one of the important things for people interest in our life. Lately, the possibility of intrusion to Smart Home has increased day by day. Protection from intruders, gas's leaking, and fire are the most important things that the people have looked for in the smart home system. A normal Home Automation system is given the signals by activating the alarm and sending an SMS the specific destinations. Also, in addition to the fast development of Internet and communication technologies, homes these days have powerful abilities of communication. Improving security, comfortability, living standard, and safety that was the main purpose of developing and using the smart home as well as the energy and resources have been saved by controlling the devices remotely or by a timer to turn off the devices in a specific time. The smart home has been playing one of the important roles in developing of community.

In this thesis, two separate systems are built based on (Arduino Mega 2560). First system has designed to secure the front door of the home called FDSS (Front Door Security System) and the second system called SACU (System Alarm and Control Unit) has built to work as an alarm system with monitoring and controlling the environment of inside the home by using several types of sensor and components. The FDSS system is working with two types of authorizations entry, first by using RFID technology and second by using a password with Keypad 4x4.

The SACU system is working based on GSM network technology to send SMS warning message to a phone number. That SMS content of text that tell which one of

these sensors (fire, gas leak, motion, and intruders) detects something. And the Bluetooth connection for controlling the light-bulbs and fans inside the home by turning them ON/OFF. The two systems are presented a highly flexible and extensible with low cost and energy for users' needs with security concerns.

4.2. Limitation

First, the Bluetooth device has used to be the communication medium for controlling the lights and fans, and that device has a limited range which is 10 Meters approximately. Second, the GSM unit has used in the SACU system module and this component should have a good signal of communication from cellular tower, and also enough credit to make sure of sending the warning SMS. Third, the humidity and temperature degree can only be displayed on the screen of main system (SACU) by pressing B button on the keypad (can't display the humidity and temperature degree remotely on the app's screen).

4.3. Future Work

In future work, we propose to control more home appliances (Such as; air conditioner, heater of water, TV, and etc..) and can increase the distance of the Bluetooth range by using Wi-Fi for controlling the home electrical devices.

Besides, we can use Wi-Fi technology via internet connection to send E-mail warning messages beside the SMS message in order to make a backup path in case of error or failure appear in one of these paths.

Also, the finger print device can be used with FDSS and SACU systems to make these systems, multi-optional and more security for the entire home. And we suggest also to install several cameras inside and outside the home. These cameras can be programmed and connected to the smart home to be activated when the alarm worked to take multi-screen shots and sending the images via MMS by GSM network or/and E-mail by internet.

REFERENCES

1. **Suresh J. P., Vijay D., Parthasarathy V., and Aswathy R. H., (2014)**, “*A State of The Art Review on The Internet of Things (IoT) History, Technology and Fields of Deployment*”, International Conference on Science, Engineering and Management Research (ICSEMR 2014) 978-1-4799-7613-3/14/\$31.00 ©2014 IEEE.
2. **Alaa M., Zaidan A. A., Zaidan B. B., Talal M., and Kiah M. L. M., (2017)**, “*A Review of Smart Home Applications Based on Internet of Things*”, Journal of Network and Computer Applications 97 (2017) 48–65.
3. IERC
at : http://www.internet-of-things-research.eu/about_iot.html.
(Data Download Date : 15.07.2017)
4. **Gubbi J., Buyya R., Marusic S., and Palaniswami M., (2013)**, “*Internet of Things (IoT): A Vision, Architectural Elements, and Future Directions*”, Future Generation Computer Systems, vol. 29, no. 7, pp. 1645 – 1660.
5. **Abuarqoub A., Hammoudeh M., Adebisi B., Jabbar S., Bounceur A., and Al-Bashar. H., (2017)**, “*Dynamic Clustering and Management of Mobile Wireless Sensor Networks*” Computer Networks, vol. 117, no. C, pp. 62–75.
6. **Stallings W., (2015)**, “*Foundations of Modern Networking: SDN, NFV, QoE, IoT, and Cloud*”, First Edition-Wesley Professional.
7. **Hendricks D., (2017)**, “*The History of Smart Homes*”,
at:<http://www.iotevolutionworld.com/m2m/articles/376816-history-smart-homes.html>.
(Data Download Date : 18.07.2017)

8. **Bosomworth D., (2017),** “*Mobile Marketing Statistics 2015*”, at:<http://www.smartinsights.com/mobile-marketing/mobile-marketing-analytics/mobile-marketing-statistics.html>.
(Data Download Date : 20.07.2017)
9. **Brush A. B., Lee B., Mahajan R., Agarwal S., Saroiu S., and Dixon C., (2017),** “*Home Automation in the Wild: Challenges and Opportunities*”, at:http://research.microsoft.com/pubs/145863/HomeOSCHI_cameraready_Final.pdf.
(Data Download Date : 22.07.2017)
10. **Gill K., Yang S. H., Yao F., and Lu X., (2009),** “*A Zigbee-Based Home-Automation System*”, IEEE Consumer Electronics Society, vol. 55, no. 2, pp. 422–430.
11. **Gaikwad P. P., Gabhane J. P., and Golait S. S., (2015),** ” *A Survey Based on Smart Homes System Using Internet-of-Things*”, International Conference on Computation of Power, Energy Information and Communication (ICCPEIC).
12. **Samuel S. S. I., (2016),** “*A Review of Connectivity Challenges in IoT-Smart Home*”, International Conference on Big Data and Smart City (ICBDSC), IEEE.
13. **Kim J. Y., Lee H. J., and Son J. Y., (2015),** “*Smart Home Web of Objects-Based IoT Management Model and Methods for Home Data Mining*”, Asia-Pacific Network Operations and Management Symposium (APNOMS), IEEE.
14. **Galinina O., Mikhaylov K., Andreev S., Turlikov A., and Koucheryavy Y., (2015),** “*Smart Home Gateway System Over Bluetooth Low Energy with Wireless Energy Transfer Capability*”, EURASIP Journal on Wireless Communications and Networking 2015 (1), 1–18.
15. **Jiang Y., Liu X., and Lian S., (2016),** “*Design and Implementation of Smart-Home Monitoring System with The Internet of Things Technology*”, In: Wireless Communications, Networking and Applications. Lecture Notes in Electrical Engineering 348. Springer, New Delhi, India, 473–484.

16. **Lee C., Zappaterra L., and Choi K., (2014)**, “*Securing Smart Home: Technologies, Security Challenges, and Security Requirements*”, Conference on Communications and Network Security (CNS), IEEE.
17. **Huang Z., Lin J.K., Yu S. Y., and Hsu J. Y., (2014)**, “*Co-locating Services in IoT Systems to Minimize the Communication Energy Cost*”, Journal of Innovation in Digital Ecosystems, 1 (1), 47–57.
18. **Tian C., Chen X., and Guo D., (2015)**, “*Analysis and Design of Security in Internet of Things*”, International Conference on Biomedical Engineering and Informatics (BMEI). IEEE.
19. **Chen C. Y., Fu J. H., Sung T., Wang P. F., Jou E., and Feng M. W., (2014)**, “*Complex Event Processing for The Internet of Things and Its Applications*”, International Conference on Automation Science and Engineering (CASE), IEEE.
20. **Bing K., Fu L., Zhuo Y., and Yanlei L., (2011)**, “*Design of an Internet of Things-Based Smart Home System*”, International Conference on Intelligent Control and Information Processing (ICICIP), IEEE.
21. **Zanjali S. V., and Talmale G. R., (2016)**, “*Medicine Reminder and Monitoring System for Secure Health Using IOT*”, Procedia Computer Science, Vol 78, PP. 471-476.
22. **Zhang Q., Chen Z., and Zhang P., (2012)**, “*Internet of Things Applied in The Home-Based Caring System for The Aged*”, Electronic Commerce, Web Application and Communication. Springer, 467–471.
23. **Moser K., Harder J., and Koo S. G., (2014)**, “*Internet of Things in Home Automation and Energy Efficient Smart Home Technologies*”, International Conference on Systems, Man, and Cybernetics (SMC), IEEE.
24. **Trincherro D., Stefanelli R., Brunazzi D., and Casalegno A., (2011)**, “*Integration of Smart House Sensors into a Fully Networked (web) Environment*”, SENSORS, 978-1-4244-9289-3/11/\$26.00 ©2011 IEEE.
25. **Shamszaman Z. U., Lee S., and Chong I., (2014)**, “*WoO Based User Centric Energy Management System in The Internet of Things*”, International Conference on Information Networking 2014 (ICOIN2014). IEEE.

26. **Madakam S., and Ramaswamy R., (2014)**, “*Smart Homes (Conceptual Views)*”, International Symposium on Computational and Business Intelligence (ISCBI), IEEE.
27. **Bhide V. H., and Wagh S., (2015)**, “*I-learning IoT: An Intelligent Self-Learning System for Home Automation Using IoT*”, International Conference on Communications and Signal Processing (ICCSP), IEEE.
28. **Pandey S., Paul A., and Chanu L. J., (2015)**, “*Life-Cycle Tracking System of Home Automation Devices (LED Bulbs)*”, International Conference on Green Computing and Internet of Things (ICGCIoT), IEEE.
29. **Billure R., Varun M., Tayur V. M., and Mahesh V., (2015)**, “*Internet of Things - A Study on The Security Challenges*”, IEEE International Advance Computing Conference (IACC).
30. **Patru I. I., Carabaş M., and Barbulescu M., (2016)**, “*Smart Home IoT System*”, RoEduNet Conference: Networking in Education and Research, IEEE.
31. **Manikandan J., (2016)**, “*Design and Evaluation of Wireless Home Automation Systems*”, IEEE 1st International Conference on Power Electronics, Intelligent Control and Energy Systems (ICPEICES).
32. **Arduino Website**
At: <http://arduino.cc/en/Guide/Introduction>.
(Data Download Date : 11.08.2017)
33. **Wu D. L., Wing W. Y., Yeung D. S., and Ding H. L., (2009)**, “*A Brief Survey on Current RFID Applications*”, International Conference on Machine Learning and Cybernetics, vol. 4, pp. 2330-2335.
34. **Souissi S., and Mehofer E. F., (2000)**, “*Performance Evaluation of a Bluetooth Network in The Presence of Adjacent and Co-Channel Interference*”, IEEE Emerging Technologies Symposium on Broadband, Wireless Internet Access. Digest of Papers (Cat. No.00EX414).

35. MIT INVERTOR2 Website

At: <http://appinventor.mit.edu/explore/designer-blocks.html>.

(Data Download Date : 22.08.2017)

36. TEPE Home Alarm System

At: <https://www.tepeguvenlik.com.tr/en/home-alarm-systems>.

(Data Download Date : 8.07.2018)

37. PRONER Home Alarm System

At: <https://www.pronet.com.tr/ev-guvenligi>.

(Data Download Date : 8.07.2018)



APPENDICES A

CURRICULUM VITAE

PERSONAL INFORMATION

Surname, Name: AL-SAMARRAEI, Yasser Samir Hadi
Date and Place of Birth: 13 October 1984, Baghdad / Iraq
Country of Origin: Iraq
Marital Status: Married
Phone 1: +90 5310393873
Phone 2: +964 770 7788584
Email 1: yassersamirhadi@gmail.com



EDUCATION

Degree	Institution and the location	Year of Graduation
<i>M.Sc.</i>	<i>Çankaya University, Computer Engineering</i> / <i>Ankara, Turkey</i>	<i>2018</i>
<i>B.Sc.</i>	<i>Baghdad College for Economic Sciences University, Computer sciences</i> / <i>Baghdad, Iraq</i>	<i>2009</i>
<i>High School</i>	<i>TATWAN</i> / <i>Baghdad, Iraq</i>	<i>2003</i>

WORK EXPERIENCE

Year	Place	Enrolment
<i>2003-2006</i> <i>2009-2014</i>	Computer and Internet Services, <i>Iraq</i>	<i>Work</i>
<i>2007-2008</i>	Testing and Maintenance of Mobiles Services, <i>Syria</i>	<i>Work</i>
<i>2010</i>	Independent High Electoral Commission, <i>Iraq</i>	<i>Work</i>
<i>2016-2017</i>	Human Resource Development Foundation, <i>Turkey</i>	<i>Work</i>

LANGUAGES

Arabic: Native

English: Advanced

Turkish: Pre-Intermediate

HOBBIES

Video Game, Football, Tennis, Cycling, Chess, Puzzle