



YAŞAR UNIVERSITY  
GRADUATE SCHOOL OF NATURAL AND APPLIED SCIENCES

MASTER THESIS

## **FUEL THEFT DETECTION SYSTEM**

ASLIGÜL PALA BAYSAK

THESIS ADVISOR: PROF. DR. MUSTAFA GÜNDÜZALP

ELECTRICAL AND ELECTRONICS ENGINEERING

PRESENTATION DATE: 28.08.2019

BORNOVA / İZMİR  
AUGUST 2019



We certify that, as the jury, we have read this thesis and that in our opinion it is fully adequate, in scope and in quality, as a thesis for the degree of Master of Science.

**Jury Members:**

Prof. Dr. Mustafa GÜNDÜZALP  
Yaşar University

**Signature:**

Dr. Öğr. Üyesi Reyat YILMAZ  
Dokuz Eylül University

Dr. Öğr. Üyesi Gökhan DEMİRKIRAN  
Yaşar University

Prof. Dr. Cüneyt GÜZELİŞ  
Director of the Graduate School



## **ABSTRACT**

### **FUEL THEFT DETECTION SYSTEM**

Pala Baysak, Aslıgül

MSc, Electrical and Electronics Engineering

Advisor: Prof. Mustafa GÜNDÜZALP

August 2019

In today's technology, wireless communication devices with Bluetooth have started to take an important part of daily lives and is rapidly growing. At this point, researches are made about the low power consumption of the devices, fast and secure communication. Bluetooth Low Energy (BLE) ensures these requirements and is developing day by day to provide a low-energy and low-cost solution for the Internet of Things (IoT). Nowadays, in-vehicle electronics technology is becoming essential with respect to customer needs. According to the claim report results of one of the reputable automotive manufacturers indicates that the crucial expectation of prospects and customers is to have safety electronic systems and following up the status of the car remotely. Due to this reason consumer electronics and internet of things (IoT) technologies are depending on the assessment of needs. In order to follow up the status of the car remotely, Bluetooth Low Energy technology (BLE) and acceleration sensors are widely used in vehicle electronics.

In this study, a prototype fuel level control system is implemented using wireless sensor networks via BLE. The fuel level sensor is placed into the fuel tank to collect the data. Fuel levels are measured inside the fuel cap for different scenarios. If an abrupt change occurs in the fuel level, the users are informed via a vehicle tracking system. The data set was generated according to the variation of fuel height and currents. "Current" is the dependent variable and "height" is the independent factor. For this reason, to compare the values, one-way analysis of variance (ANOVA) was implemented. At first, the hypotheses of homogeneity and ANOVA were established. The significance level was chosen as  $\alpha = 5\%$  (0.05). It means that the results have a 95% chance of being true and have a 5% chance for being false. The SPSS results

represent

95% confidence intervals. As a result of the ANOVA test, it is obtained that the different hole diameter has the same effect to generate the R (ohm).

The current work aims to process data locally, transmitting via Bluetooth Low Energy and reporting the output data. The results/outputs of the system implementation are evaluated statistically with experimental design.

**Key Words:** IoT, Bluetooth Low Energy (BLE), Smart Sensor, Digital Fuel Level, Fuel Security System



## ÖZ

### FUEL THEFT DETECTION SYSTEM

Pala Baysak, Aslıgül

Yüksek Lisans, Elektrik Elektronik Mühendisliği

Danışman: Prof. Dr. Mustafa GÜNDÜZALP

Ağustos 2019

Günümüz teknolojisinde Bluetooth ile kablosuz haberleşen cihazlar günlük hayatta önemli bir yer almaya ve sıklıkla kullanılmaya başlanmıştır. Bu kapsamda cihazların düşük güç tüketimi, hızlı ve güvenli bir şekilde haberleşmesi üzerinde araştırmalar yapılmaktadır. Bu özellikleri sağlayan ve gün geçtikçe gelişmekte olan Bluetooth Düşük Enerji teknolojisi (BLE), düşük enerji tüketimi ve düşük maliyetli bir çözüm sunmaktadır. Günümüzde, araç içi elektronik teknolojisi müşteri ihtiyaçlarına göre değişkenlik göstermektedir. Saygın otomotiv üreticileri potansiyel müşterilerin istek ve ihtiyaçlarını inceleyerek en önemli beklentilerinin emniyetli elektronik sistemlere sahip olmak ve aracın durumunu uzaktan izlemek olduğunu göstermiştir. Bu sebeple aracın uzaktan durumunu takip etmek için, araç elektroniğinde Bluetooth Low Energy teknolojisi (BLE) ve hızlanma sensörleri yaygın olarak kullanılmaktadır.

Bu çalışmada, BLE yoluyla kablosuz sensör ağları kullanılarak yakıt seviyesi kontrol sistemi kurulmuştur. Araç park pozisyonunda ve kontak kapalı iken belirli zaman aralıklarında devreye giren sensör ile yakıt seviyesi ölçümünü sağlayan yakıt ölçüm sensörünün haberleşmesi sağlanarak verinin araç takip sistemi ile haberleşerek araç sahiplerine iletilmesi hedeflenmiştir. Veri seti yakıt seviyesi değişimine bağlı yakıt seviye sensörü üzerinde oluşan direncin ölçümü ile elde edilen akım değerlerinden oluşmuştur. Akım bağımlı değişken olarak seçilirken, yakıt seviyesi yüksekliği bağımsız değişken olarak belirlenmiştir. Yakıt tankından yakıt alınması çeşitlerinden birisi olan tankın alt tarafından delinerek boşalması senaryosu baz alınarak üç farklı delik çapının boşalmanın yakıt seviye sensörü üzerindeki etkisi incelenmiştir. Bu nedenle oluşan değerleri kıyaslama amacıyla tek yönlü varyans analizi yöntemi (ANOVA) seçilmiştir. İlk aşamada homojenlik ve normallik testleri yapılarak

ANOVA analizine uygunluk deęerlendirilmiřtir. nem seviyesi %95 olarak seilerek sonularda %5 hata payı bırakılmıřtır. ANOVA testi sonularına gre u farklı delik apının yakıt seviyesi sensr zerinde voltaj oluřturulmasında aynı etkiyi gsterdikleri saptınmıřtır. Mevcut alıřma, yerel olarak veri iřlemeyi, Bluetooth Low Energy ile veri iletmeyi ve ıktı verilerini raporlamayı amalamaktadır. Uygulama istatistiksel deney tasarımı ile analizlenmiřtir.

**Anahtar Kelimeler:** IoT, Bluetooth Dřk Enerji, Akıllı Sensr, Dijital Yakıt Seviyesi, Yakıt Gvenlik Sistemi



## ACKNOWLEDGEMENTS

First of all, I would like to thank my supervisor Prof. Dr. Mustafa Gündüzalp for his guidance and patience during this study.

I thank to Serhat Sandalcı (General Manager), Adnan Üsküdar (R&D Manager) and Nesan Otomotiv A.Ş. for their valuable support and cooperation. I would like to thank my best friend Lecturer Ruti Politi for her continuous advice for academic purposes.

I would like to express my gratitude to the jury members Asst. Prof. Reyat Yılmaz and Asst. Prof. Gökhan Demirkıran for their valuable advice.

This work would not have been possible without the support of my company VeriPark and my manager Atakan Pehlivanoğlu (Senior Manager) and Alpaslan Özlü (General Manager) who have been supportive of my career goals.

I must express my very profound gratitude to my mother Prof. Dr. Ayşegül Pala, my father Mehmet Mazhar Pala, my husband Emir Arslan Baysak and my aunt Prof. Dr. Leyla İyilikçi Karaoğlan for providing me with unfailing support and continuous encouragement throughout my years of study and through the process of researching and writing this thesis. This accomplishment would not have been possible without them.

Aslıgül PALA BAYSAK

İzmir, 2019

## TEXT OF OATH

I declare and honestly confirm that my study, titled “FUEL THEFT DETECTION SYSTEM” and presented as a Master’s Thesis, has been written without applying to any assistance inconsistent with scientific ethics and traditions. I declare, to the best of my knowledge and belief, that all content and ideas drawn directly or indirectly from external sources are indicated in the text and listed in the list of references.

Aslıgül Pala Baysak

.....

October 4, 2019



# TABLE OF CONTENTS

ABSTRACT.....	v
ÖZ.....	vii
ACKNOWLEDGEMENTS.....	ix
TEXT OF OATH.....	x
TABLE OF CONTENTS.....	xi
LIST OF FIGURES.....	xiii
LIST OF TABLES.....	xv
SYMBOLS AND ABBREVIATIONS.....	xvi
CHAPTER 1 INTRODUCTION.....	1
1.1 RESEARCH PROBLEM STATEMENT.....	1
1.2 THE OBJECTIVE OF THE THESIS.....	3
CHAPTER 2 BACKGROUND – LITERATURE REVIEW.....	4
2.1 VEHICLE ELECTRONICS AND NETWORKS.....	4
2.2 BLUETOOTH.....	4
2.3 BLUETOOTH LOW ENERGY (BLE).....	5
2.4 BLE LAYERS.....	9
2.4.1 APPLICATION.....	9
2.4.2 HOST.....	9
2.4.3 CONTROLLER.....	10
2.5 SMART SENSOR.....	15
CHAPTER 3 MATERIAL AND METHODS.....	17
3.1 SYSTEM OVERVIEW.....	17
3.2 DEVICES AND PROGRAMS.....	18
3.2.1 NRF51824 – NORDIC SEMICONDUCTOR.....	18
3.2.2 NRF51 DONGLE.....	23

3.3 APPLICATION OVERVIEW .....	26
3.3.1 DEVELOPING WITH THE MDK-ARM MICROCONTROLLER DEVELOPMENT KIT.....	26
3.3.2 TESTING.....	26
3.4 FUEL LEVEL SENSOR .....	28
CHAPTER 4 APPLICATION .....	33
4.1 SYSTEM MODELING .....	33
4.1.1 3 MM OF HOLE DIAMETER .....	37
4.1.2 5 MM OF HOLE DIAMETER .....	38
4.1.3 10 MM OF HOLE DIAMETER .....	38
4.2 STATISTICAL EVALUATION.....	39
4.2.1 TEST OF NORMALITY .....	42
4.2.2 ANOVA EXPERIMENTAL DESIGN .....	44
CHAPTER 5 CONCLUSION.....	47
REFERENCES .....	49

## LIST OF FIGURES

<b>Figure 2-1</b> Bluetooth Classic and Smart usage areas .....	6
<b>Figure 2-2</b> The evaluation of Bluetooth .....	7
<b>Figure 2-3</b> Star typology of a piconet .....	7
<b>Figure 2-4</b> BLE Architecture .....	9
<b>Figure 2-5</b> BLE communication band.....	11
<b>Figure 2-6</b> The stack diagram of the SoftDevice .....	12
<b>Figure 2-7</b> BLE link layers of the roles.....	13
<b>Figure 2-8</b> Link-layer change example of a BLE connection .....	13
<b>Figure 2-9</b> BLE discovery phase.....	14
<b>Figure 2-10</b> Slave negotiation parameters.....	15
<b>Figure 2-11</b> Wireless sensor topologies .....	16
<b>Figure 3-1</b> Fuel theft detection process .....	17
<b>Figure 3-2</b> The Development Kit content of the nRF51 .....	19
<b>Figure 3-3</b> BLE spectrum captured using nRF connection of 40 channels.....	20
<b>Figure 3-4</b> BLE spectrum captured using nRF connection with Advertisement channels....	20
<b>Figure 3-5</b> Block diagram of the sensor.....	21
<b>Figure 3-6</b> Pin assignment.....	21
<b>Figure 3-7</b> nRF BLE controller architecture diagram for RTOS-free environment.....	22
<b>Figure 3-8</b> nRF BLE Controller architecture diagram for RTOS .....	23
<b>Figure 3-9</b> nRF51 Dongle content.....	24
<b>Figure 3-10</b> nRF Dongle top and bottom .....	24
<b>Figure 3-11</b> nRF51 Dongle block diagram .....	24
<b>Figure 3-12</b> The interface of the microcontroller.....	25
<b>Figure 3-13</b> LED configuration of the dongle.....	25

<b>Figure 3-14</b> Fuel level sensor working principle .....	29
<b>Figure 3-15</b> The fuel level sensor ON/OFF mode .....	29
<b>Figure 3-16</b> Fuel level sensor on prototype.....	30
<b>Figure 3-17</b> Circuit diagram of the fuel level sensor .....	30
<b>Figure 3-18</b> Fuel level sensor section A-A .....	31
<b>Figure 3-19</b> Fuel level sensor.....	32
<b>Figure 3-20</b> Installation prototype of the fuel level sensor into the fuel tank .....	32
<b>Figure 4-1</b> Product map.....	33
<b>Figure 4-2</b> Development Kit -top.....	34
<b>Figure 4-3</b> Development kit - bottom.....	34
<b>Figure 4-4</b> Connections.....	35
<b>Figure 4-5</b> Flow diagram of the project .....	35
<b>Figure 4-6</b> Fuel tank of a commercial truck.....	36
<b>Figure 4-7</b> Fuel Level Height – R trends for three different hole diameter .....	40
<b>Figure 4-8</b> Histogram for D=3 mm .....	40
<b>Figure 4-9</b> Histogram for D=5 mm .....	41
<b>Figure 4-10</b> Histogram for D=10 mm .....	41
<b>Figure 4-11</b> Normal Q-Q plot for 3 mm hole diameter.....	43
<b>Figure 4-12</b> Normal Q-Q plot for 5 mm hole diameter.....	43
<b>Figure 4-13</b> Normal Q-Q plot for 10 mm hole diameter.....	44

## LIST OF TABLES

<b>Table 2-1</b> The main differences between Bluetooth Classic and BLE.....	8
<b>Table 4-1</b> Discharge volume of the fuel level according to the hole diameters .....	39
<b>Table 4-2</b> Test of Normality .....	42
<b>Table 4-3</b> Descriptive statistics .....	45
<b>Table 4-4</b> Test of Homogeneity of Variances .....	46
<b>Table 4-5</b> ANOVA .....	46



## **SYMBOLS AND ABBREVIATIONS**

### **ABBREVIATIONS:**

ANOVA: Analysis of Variance

BLE: Bluetooth Low Energy

DK: Development Kit

EVB: Evaluation Board

GAP: Generic Access Profile

GPIO: General Purpose Input Output

HCI: Host Controller Interface

IoT: Internet of Things

OTP: One Time Programmable (memory)

PPI: Programmable Peripheral Interconnect

RF: Radio Frequency

RTOS: Real-Time Operating System

SoC: System on a Chip



# **CHAPTER 1**

## **INTRODUCTION**

Nowadays, in-vehicle electronics technology is becoming essential with respect to customer needs. According to claim report results of one of the reputable automotive manufacturers indicates that the crucial expectation of some market prospects and customers is to have safety electronic systems and following up the status of the fuel level of the vehicle remotely. Due to this reason consumer electronics and internet of things (IoT) technologies are depending on the assessment of needs. In order to follow up the status of the car remotely, Bluetooth Low Energy technology (BLE) and fuel level sensors are widely used in vehicle electronics. Bluetooth Low Energy is one of the latest developed technologies feeding consumer electronics. The benefits to design and implement Bluetooth Low Energy technology on low-cost applications are able to execute and communicate in mobile environments.

### **1.1 Research Problem Statement**

Fuel costs constitute the biggest expense item of the transportation sector. At this point, automotive companies want to offer innovative and technological solutions to prevent fuel discharges as a result of fuel abuse and unauthorized discharge from the tank. Fuel theft is an event that concern to the police and rural communities. Fuel can be stolen from trucks and their storage tanks by drilling a hole under the fuel tank with using of siphoning equipment or by cutting off fuel lines (Warwickshire Police, n.d). The demand of the companies that have faced with this situation according to the customer's feedbacks has increased the studies done in this field and has enabled to shape the test scenario of this project. According to the rise of diesel fuel prices, it has been observed that fuel theft has increased especially in big vehicles such as trucks. Especially, it is happening when the vehicle is in the parking position (Senthil, 2017). As of 2008, there are 9.653.546 motor vehicles in Turkey. 2.808.789 of them are heavy vehicles such as vans, buses, and trucks. It can be said that a truck fuel tank capacity is 500-700 liters and that fuel theft prevention systems are necessary for such type of

vehicles. On the other hand, the use of the measurement of the fuel on the fuel tank simultaneously is a subject that has been extensively researched. The new type of processors are the main elements of such systems. In addition, fuel level measurement methods are used in vehicle tracking systems. In some of the studies, nonlinear filters or wave transformations analyze data from sensors. On the other hand, using many sensors increases the cost and makes the system very complicated (Köse, et al., 2009). To overcome the theft problem, researches focus on the combination of the fuel monitoring system and mobile communication technology which send reports automatically via SMS to the owner of the vehicle (Senthil, 2017).

It is already stated that the current work aims to process data locally, transmitting via Bluetooth Low Energy and reporting the output data.

This thesis combines the advantages of the lowest power, and lowest system cost Bluetooth low energy System-on-Chip with an integrated flash.

The purpose of this thesis is to develop an embedded system, which is communicating with each other using Bluetooth Low Energy the remote control, which get executed instantly.

The core concept of the Internet of Things is to enable things to be connected anytime, anyplace, with anything and anyone ideally using any path/ network and any service.

Goundar et al. (2014) presented a design solution to monitor the fuel level by using a pressure sensor. An automatic measurement controlling fuel tank fuel level was designed with BMP085 pressure sensor. The regression analysis was performed to calculate the volume according to the pressure sensor readings (Goundar et al., 2014).

Lin et al. (2015) examined the potential of BLE technology for vehicular applications. Intra-vehicular wireless sensor applications in the automotive industry lead to the removal of the additional wiring system. For this reason, this new technology has great potential and accompanies many benefits to car manufacturers. An experimental platform was realized based on BLE technology to implement a passive keyless entry system. Due to the experiments, the cost of the existing system was decreased during the system was worked properly and the car was unlocked every time (Ling et al., 2015).

Winkel (2016) investigated the performance of BLE in the in-vehicle environment. The parameters were selected as the message error rate, packet error rate and latency

of BLE wireless links. The static and dynamic test parameters were described then the experiments were realized with two different vehicles (Opel Corsa and Honda Accord) on the same parking area. The experiments were conducted different days and it was rainy during the experiments. However, the influence of rain was neglected. It can be said that the BLE link delivery system worked correctly and performed with remarkable success (Winkel, 2016).

## **1.2 The objective of the Thesis**

Based on this problem statement, this thesis consists of five main chapters and subtitles.

Chapter 2 is providing the necessary background information to understand Vehicle Electronics and Networks, Bluetooth technology, GPRS and acceleration sensors.

Chapter 3 defines the background of the system. Stakeholder engagement and elicitation of the business needs are listed for the build, design and test purposes. Both functional and non-functional requirements are prioritized and committed by the automotive manufacturer. The methodology of the thesis is also described in this chapter. In-vehicle communication and smart sensor application technical background are mentioned respectively. It is focusing on introducing the DA14585 low-power Bluetooth low energy (4.0) and NRF acceleration sensor. The aim was to implement Bluetooth 5.0 with another sensor. However, due to the lack of unsuccessful connections and inefficiency, the thesis is redesigned with respect to Bluetooth 4.0.

Statistical analysis is described in Chapter 4. The results/outputs of the system implementation are evaluated the statistically experimental design.

Chapter 5 is the final chapter defines conclusion and recommendation to move forward to improve IoT usage in automotive electronics regarding customer needs and claims.

## **CHAPTER 2**

### **BACKGROUND – LITERATURE REVIEW**

#### **2.1 Vehicle Electronics and Networks**

Nowadays, new features are continuously integrating into vehicles electronics in the automobile industry (Alam, 2018). Electronic devices used in vehicles are increasing day by day. This augmentation in vehicles brings the need to communicate with the central computer of the vehicle. This technology can be divided into two groups as wired and wireless. The challenges of wired in-vehicle networks have led to alternative research areas. In order to reduce these difficulties, a solution method is used in which some part of the wired parts is removed and replaced by wireless connection. Some parts of the wiring loom can be replaced by Bluetooth, BLE or ultra-wideband link. Thus, the use of wireless technology provides some advantages such as reduced wiring loom installation time, reduced vehicle weight, improved fuel economy, and reduced material costs. However, new challenges are encountered, such as inherent unreliability, lack of security, and threats to the confidentiality of wireless connections. The remote keyless entry system or the wireless tire pressure management systems are examples of existing commercially wireless applications for vehicles. Generally, these applications need to use proprietary protocols (Winkel, 2016).

#### **2.2 Bluetooth**

This section describes the concepts and fundamentals of Bluetooth and Bluetooth Low Energy (BLE). Bluetooth is a short-range Radio Frequency (RF) wireless communication technology which provides low cost and low power consumption (Elhesseawy and Riad, 2018). Ericsson developed Bluetooth technology in 1994 as a wireless alternative to the RS-232 data cables for close distances and nowadays it has a wide range of applications today. Bluetooth devices have two different forms: Basic Rate (BR) and Low Energy (LE). Both systems have main features such as device recognition and connection generation. The BR systems also include Enhanced Data

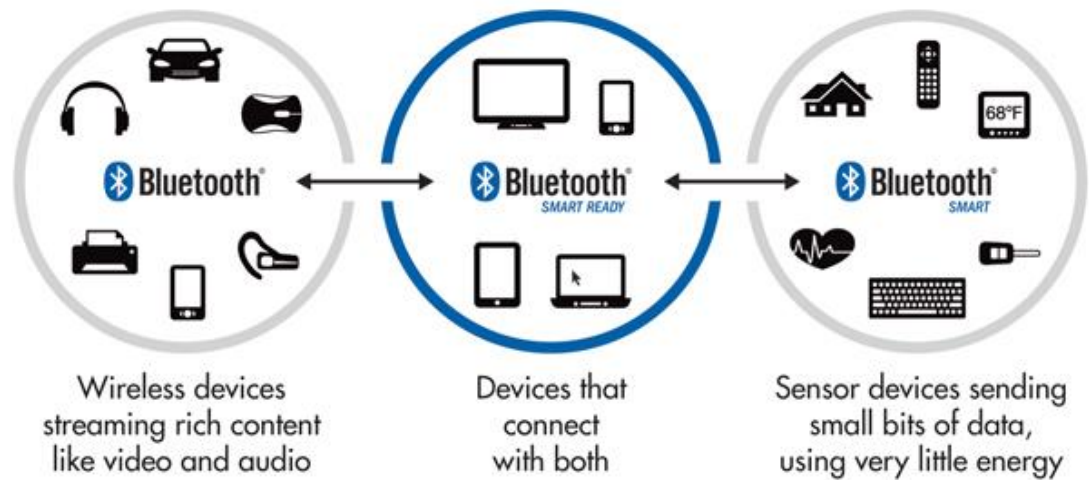
Rate (EDR) as an option (Bal, 2015). The BR/EDR systems are classified as classic Bluetooth, and the low energy system is known as BLE, which will be explained in the following section. Any device that used Bluetooth technology can operate not only BR or LE technology but also can operate both systems at the same time. The BR and BLE have similar bit rate and can support a higher bit rate of 1 Mbps, and the EDR supports a maximum bit rate of 2 or 3 Mbps (Elhesseawy and Riad, 2018). In order to use both system features, the communication can only be realized in the same form of the device which recognizes each other (Bal, 2015). The Bluetooth devices operate in the Industrial, Scientific and Medical (ISM) band at 2.4 GHz which can be used unlicensed.

The Bluetooth profile is necessary for communication between different Bluetooth devices. The Bluetooth profile identifies the characteristics of the core specifications and depends on the application area. For example, the profile must include standardization to control TV, Hi-Fi or other types of Bluetooth equipment to realize an audio remote control. The main factor to perform a successful operation is to support the same protocol (Elhesseawy and Riad, 2018).

### **2.3 Bluetooth Low Energy (BLE)**

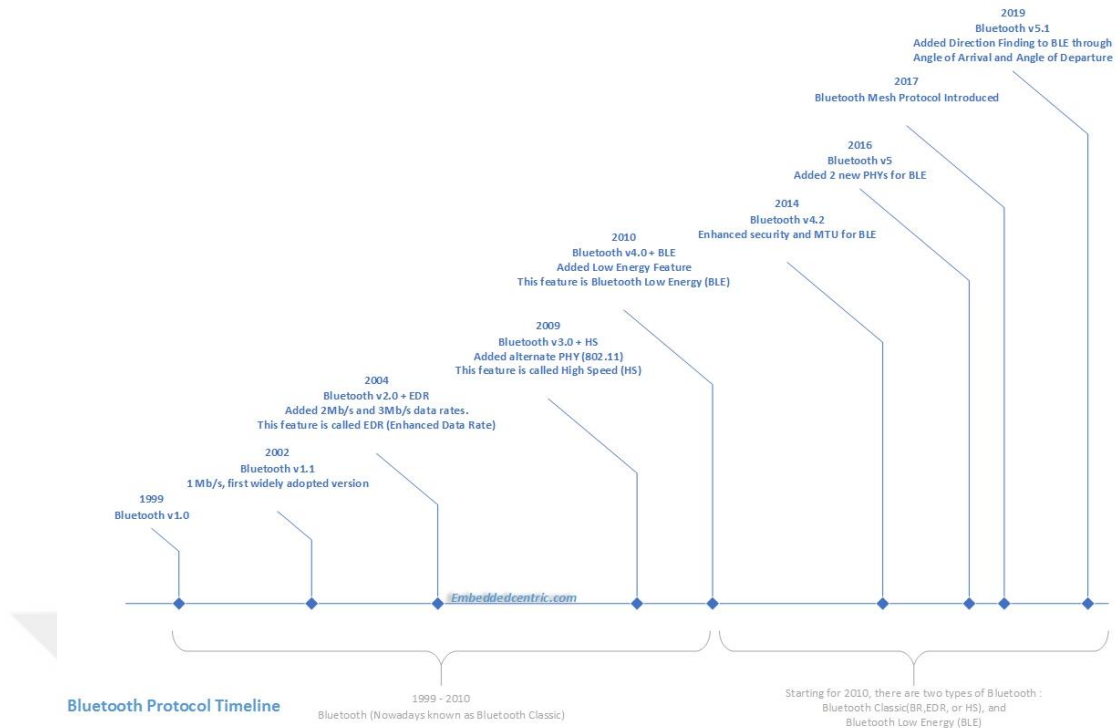
Bluetooth Low Energy (BLE) has become a dominant technology to connect the Internet of Things (IoT). It is also known as Bluetooth Smart has become essential in many devices and has a wide usage area which can be seen in **Error! Reference source not found.** It can be operated in medical devices, smart homes, cell phones, speakers, printers, keyboards, automobiles, etc. This technology provides remote monitor and control (Lonzetta et al., 2018). It is a short-range wireless standard to reduce power consumption through faster connections by transferring data with lower latency (Digi-Key Electronics, 2016). It provides sensor data over a long period of time by using a small device. The superiority comes from very low power consumption, fast connection times and reliable data transfer (Ohlson, 2013).

Bluetooth Classic has a short-range communication with the high audio stream. It has no regard for power consumption (Embedded Centric, 2019a).



**Figure 2-1** Bluetooth Classic and Smart usage areas  
 Source: (Digi-Key Electronics, 2016)

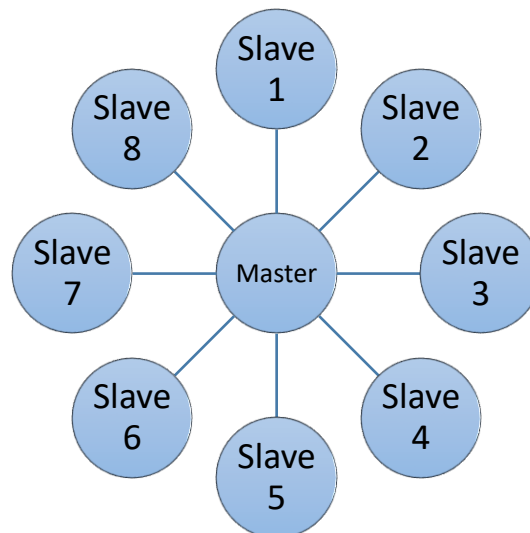
The devices can be support Classic or BLE or both of them. In **Error! Reference source not found.**, there is a type called Bluetooth Smart Ready, which includes both hardware of Classic and BLE. The application areas can be listed as smartphones, laptops (Embedded Centric, 2019a). The first BLE version 4.0 was introduced in 2010. The superiorities over the classical Bluetooth technology and the aim were “to design a radio standard with the lowest possible power consumption, specifically optimized for low cost, low bandwidth, low power, and low complexity”. BLE has grown rapidly by showing great improvement contrary to the other wireless standards (Hearndon, 2016). It has a much shorter transmission start, 3ms, than the classic Bluetooth, which has 100ms (Bjarnason, 2016). BLE and Bluetooth Classic are not compatible with each other according to diversity in hardware, architecture, specifications or applications (Embedded Centric, 2019a). The new technology Bluetooth 5.0 is much faster than the previous versions, with a wide range of domains, battery-friendly and compatible with future technologies. It provides much faster transfer data times and it saves time. In addition, the impact area of Bluetooth 5 has increased, thus the Internet of Things has reached to a new level. Bluetooth technology is very important for faster and more effective interaction between smart devices. The latest Bluetooth version 5.1 is released on 2019, which can be seen in the Bluetooth protocol history in Figure 2-2. Table 2-1 classifies the main differences between Bluetooth Classic and BLE, which is known as “Bluetooth Smart”.



**Figure 2-2** The evolution of Bluetooth

(Source: (Embedded Centric, 2019a).)

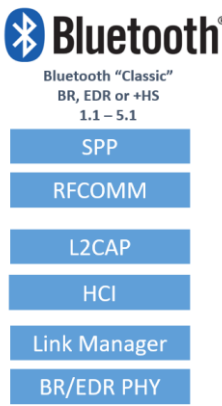
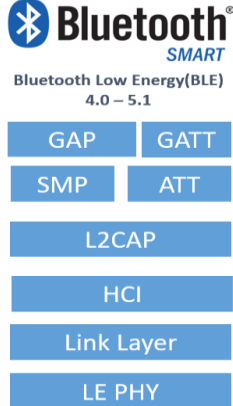
BLE works on piconets. Each piconet has a star topology as can be seen in Figure 2-3. The master node is located in the center of the star of the piconet. The other nodes are known as slaves (Winkel, 2016).



**Figure 2-3** Star typology of a piconet

Source: (Winkel, 2016)

**Table 2-1** The main differences between Bluetooth Classic and BLE

	<b>Bluetooth Classic</b>	<b>Bluetooth Low Energy</b>
Common name	Bluetooth Classic	Bluetooth Smart
Standard range	Short-range communication	Low bandwidth applications
Connection time	100 ms	Fast connection (<6 ms)
Power consumption	No regard to	Ultra-low
Utilization area	Traditional wireless devices, cars, and headsets	
Architecture diagram	 <p>The diagram for Bluetooth Classic shows a vertical stack of protocol layers. From top to bottom: SPP, RFCOMM, L2CAP, HCI, Link Manager, and BR/EDR PHY. The text above the stack reads: Bluetooth "Classic" BR, EDR or +HS 1.1 - 5.1.</p>	 <p>The diagram for Bluetooth Low Energy (BLE) shows a vertical stack of protocol layers. From top to bottom: GAP and GATT (side-by-side), SMP and ATT (side-by-side), L2CAP, HCI, Link Layer, and LE PHY. The text above the stack reads: Bluetooth SMART Bluetooth Low Energy(BLE) 4.0 - 5.1.</p>

(Source: Embedded Centric, 2019a)

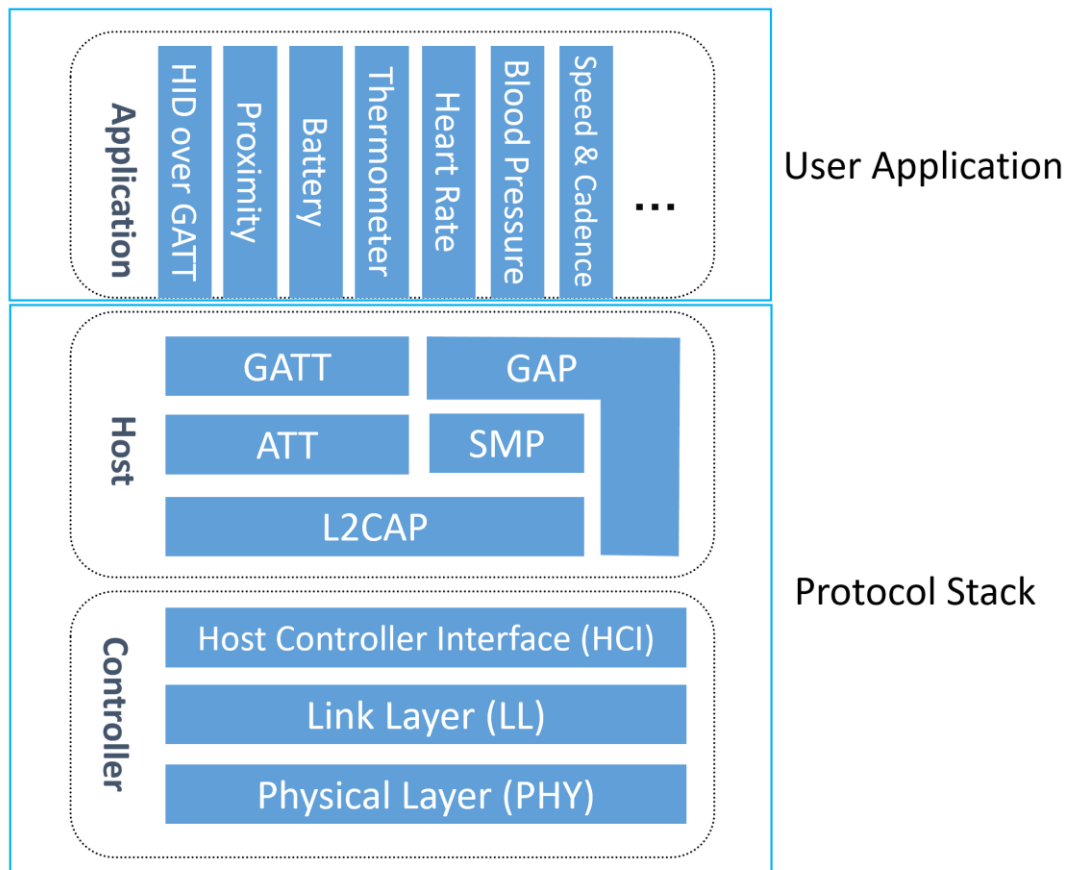
BLE communication is based on the client-server model on a single link. In this connection, the master takes on the main client role and the slave takes on the role of the server. The key to the use of BLE is a service concept. A service is described as an immutable encapsulation of some atomic behavior of a device and is located on the server. A server can run many services. A service uses one or more attributes. An addressed bit labeled data bit is called an attribute. The necessary interactions between the client and the server occur through the attributes (Winkel, 2016).

It is important to note that the nRF512824 chip, which is used in this thesis, is fully supported only by BLE.



## 2.4 BLE Layers

The BLE Architecture is a BLE protocol stack which can be defined with three main parts: (1) application, (2) host and (3) controller. Each part contains other layers which can be seen in Figure 2-4. It is called layered because it consists of different layers stacked to each other (Embedded Centric, 2019a).



**Figure 2-4** BLE Architecture

(Source: (Embedded Centric, 2019a).)

### 2.4.1 Application

The application part is the user interface part in the BLE architecture. It is shaped according to the needs and constraints of the projects (Embedded Centric, 2019a).

### 2.4.2 Host

The host interface is between the Controller and Application in the protocol stack (Embedded Centric, 2019a). The task is to send bilateral data from the user application to the controller. Two main parts as the logical interface and the physical interface are

the part of the host. Logical interface part includes Application-programming interface on the controller. The physical interface includes Universal Serial Bus, Secure Digital Input-output etc. A tablet, PC or any device that has an operating system can be the host (Kuchimanchi, 2015).

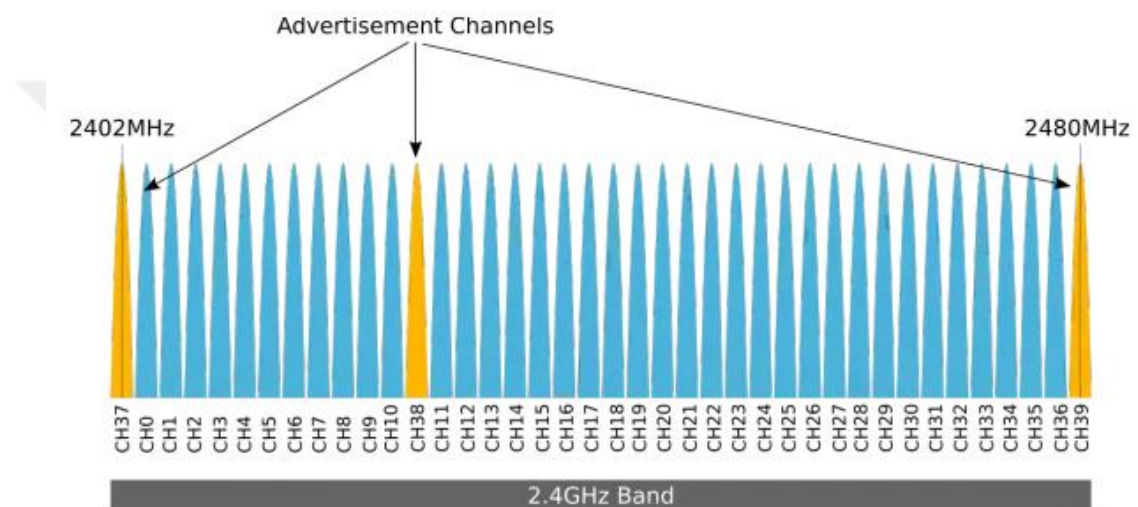
The host involves Generic Access Profile (GAP), Generic Attribute Profile (GATT), Logical Link Control and Adaptation Protocol (L2CAP), Attribute Protocol (ATT) and Security Manager Protocol (SMP). GAP layer performs the base functions between all Bluetooth devices. It works as a transceiver or operates as a transmitter so the role of the broadcaster comes from this property. It transmits advertising data at periodic intervals. This device is also a good observer, which periodically scans the channels to find out any data from any broadcaster. Moreover, if any connection is active, the device works like a central to manage all necessary settings to realize the data exchange. GATT profile is used to investigate how to obtain data from different profiles to exchange between the BLE devices (Elhesseawy and Riad, 2018). L2CAP defines as a bidirectional data channel and has two tasks as L2CAP channels and L2CAP signaling commands. ATT protocol supports information about the device. The rules to access data in any device are indicated by this protocol. It defines the attribute that expresses a value. SMP is used to pair and to provide the trust with any device (Kuchimanchi, 2015).

### **2.4.3 Controller**

The controller is the bottom layer of the architecture. It includes the radio. A controller embodies a physical layer (PHY), link layer (LL) and host controller interface (HCI). The receiving and transmitting bits of information is provided by the physical layer, which is situated at the bottom by using 2.4 GHz radio. BLE coding system is the Gaussian frequency-shift keying (GFSK) which is provided by zeroes and ones, which are coded onto the radio by slightly shifting the frequency up and down. It provides to spread out the energy over a wider range of frequencies if a dramatic frequency shift occurs. The bits are approved in the link layer as a packet of data and it is checked to send them to the protocols. This layer has advertising, scanning, creation and maintenance properties of the connection (Kuchimanchi, 2015).

The RF modulation and demodulation is supported by the PHY. The analog and digital circuitry communication of PHY provides a translation of the digital data over the air.

This layer can be mentioned as the lowest layer of the protocol stack. This layer provides the services to the LL. The communication spectrum is divided into 40 channels on 2 MHz spacing between 2.402 GHz and 2.4835 GHz. Among the 40 channels, three of them (channel 37, 38 and 39) are advertisement channels and the rests are data channels. Figure 2-5 visualizes the data and advertisement channels on the BLE communication band. Advertisement channels are responsible to discover devices during establishing the connection and broadcasting. On the other hand, data channels provide bidirectional communication between connected devices and the extensions of advertisement (Embedded Centric, 2019a).

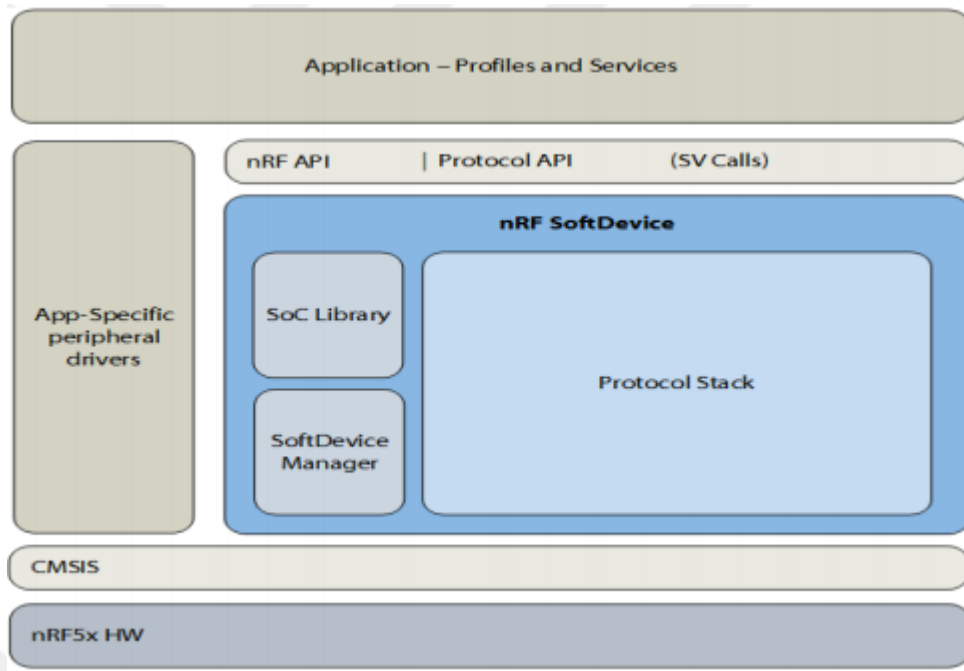


**Figure 2-5** BLE communication band

(Source: (Embedded Centric, 2019a).)

The nRF51824 chip includes BLE\_GAP\_PHY\_1MBPS type of PHY, that is capable of the BLE 4.x standard with a 1 Mbps data rate. The chip can be configured by using SoftDevice API (Embedded Centric, 2019a).

The Nordic SoftDevice is necessary to implement the wireless protocol developed by Nordic Semiconductor. It supports hardware and software during the application development. In addition, it provides program execution. The stack diagram of SoftDevice can be shown in Figure 2-6 (Lyatuu,2018).

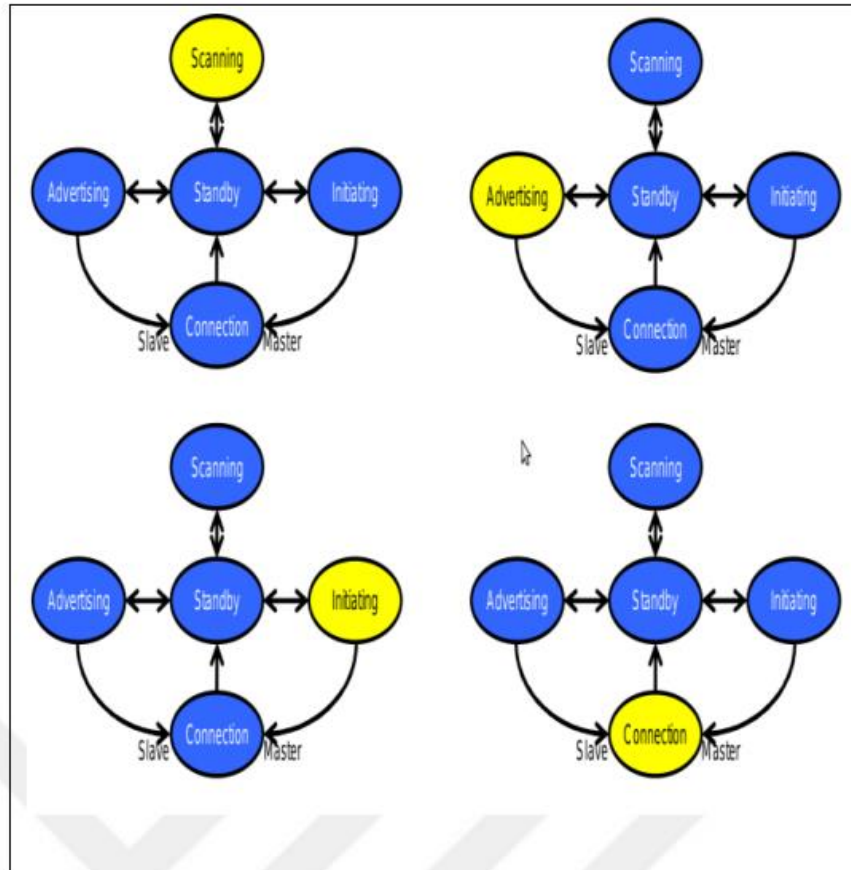


**Figure 2-6** The stack diagram of the SoftDevice

(Source: Lyatuu, 2018)

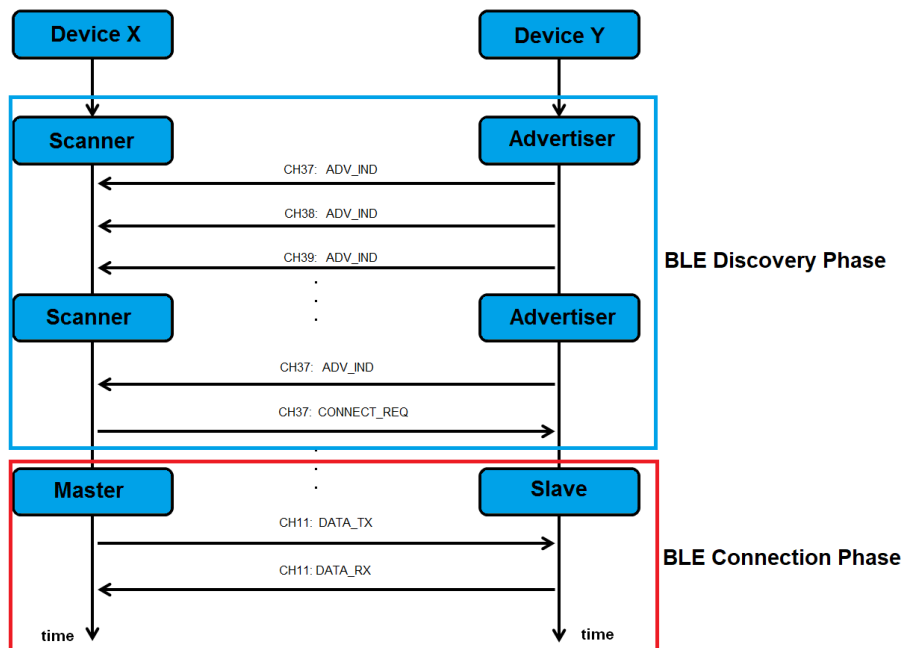
The LL is related to the physical layer and defines the four main roles and state of the device as advertiser, scanner, master or slave. The advertiser means sending the advertisement packets. The scanner is responsible to scan for advertisement packets. A master starts and manages the connection. A slave accepts the connection request to follow for the master timing. The roles and the interaction between the roles can be seen in Figure 2-7. In addition, LL has a role to advertise, scan and maintain the connections. It encapsulates the data from the upper layers to generate BLE packets (Embedded Centric, 2019a).

The LL can change its own role during the connection. For example, it can start with a scanner role and it can become a master. An example can be seen in Figure 2-8. Device X has a scanner role to connect Device Y. If Device Y is picked by handshaking than the role of Device X is going to change from the scanner to master. And also the advertiser becomes the slave (Embedded Centric, 2019a).



**Figure 2-7** BLE link layers of the roles

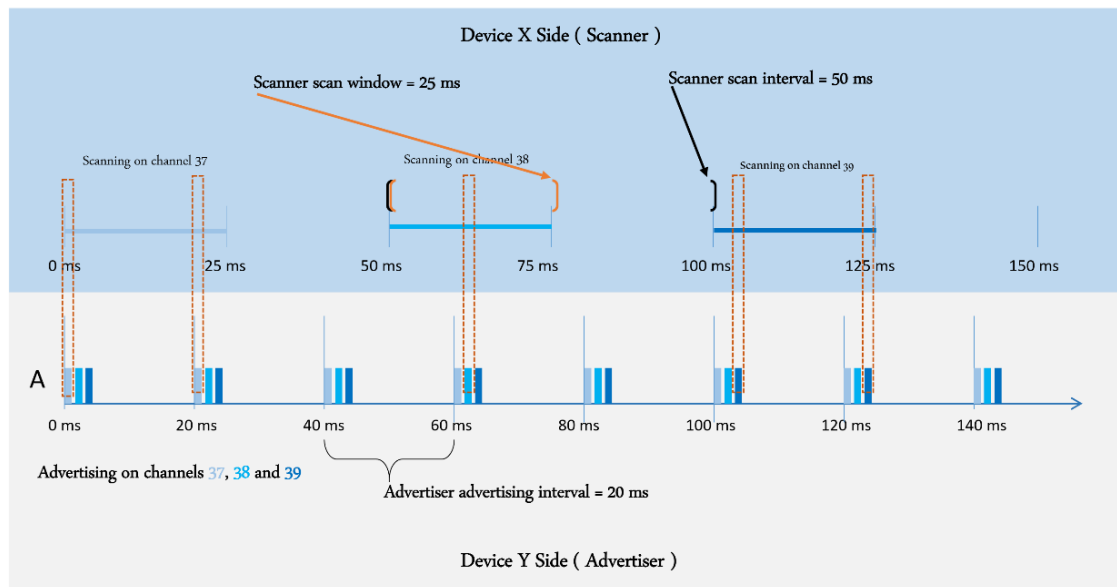
(Source: Lyatuu,2018.)



**Figure 2-8** Link-layer change example of a BLE connection

(Source: (Embedded Centric, 2019a).)

BLE discovery phase can be seen if the devices are on advertiser/scanner pairs. When a device is advertising, the same advertisement packet is sending to 37,38 and 39 channels of advertising. The advertiser sends “Advertiser Advertising Interval” and this parameter is configured out by SoftDevice API. Contrary, the scanner device also sends its “Scanner Scan Interval” when it is needed instead of scanning continuously. During this interval, “Scanner Scan Window” is active. In the discovery phase of BLE, the bottom of the device is responsible as an advertiser and the top is acting as a scanner. Figure 2-9 shows this situation of the scan window and scan interval (Embedded Centric, 2019a).

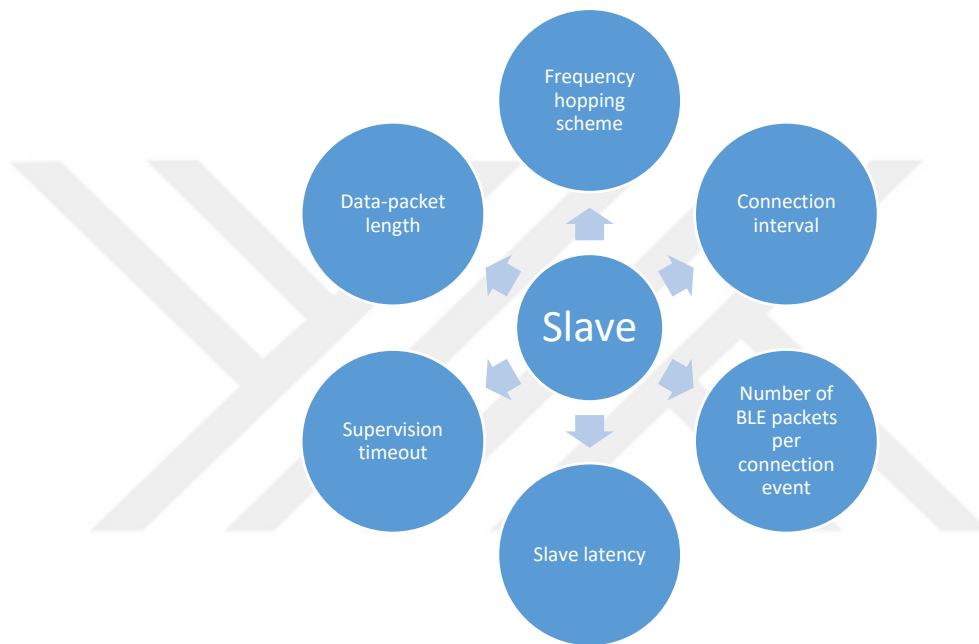


**Figure 2-9** BLE discovery phase

(Source: (Embedded Centric, 2019a).)

When the Scanner is full of data from Advertiser, the BLE connection process starts. The Scanner is getting Master of LL and the Advertiser is the Slave of LL of the connection. Figure 2-10 demonstrates negotiation parameters between the Slave and the Master for BLE connection. The responsibility of the frequency hopping scheme is the reduction of interferences in the account of devices. The aim is to predict the channel list within the 37 data channels which will be used. Connection interval is the sequential connection time between the events. Generally, the connection interval is between 7.5 millisecond and 4 seconds. Low values give high data throughput with high power consumption contrary to the high values which indicate low power

consumption. The number of BLE packets per connection event is related to the Library/OS used in the system. Slave latency is needed to cut the connection events when there is no data sent. It is an effective parameter which decreases the unnecessary power consumption on the slave side. Typical values are among 0 and 449. Supervision timeout is defined as the length of time between the Master waiting time for a response and the Slave. Usually, this value is between 10 millisecond and 32 seconds. The last parameter Data-packet length which is related with the BLE version (Embedded Centric, 2019a).



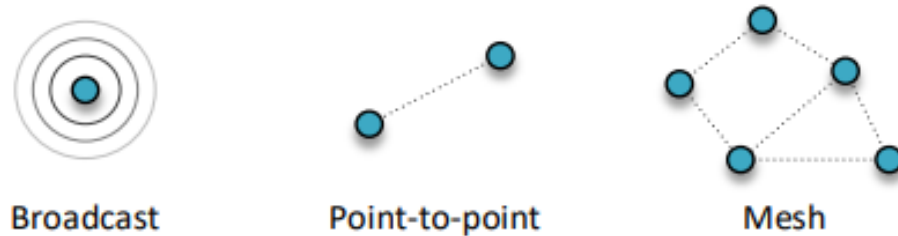
**Figure 2-10** Slave negotiation parameters

(Source: (Embedded Centric, 2019a).)

## 2.5 Smart Sensor

Smart sensor technology has a wide range of application area to gather information as wireless to improve daily life. It transmits wirelessly the measurements to a remote receiver. Wireless sensor communication network is divided into three; broadcast networks, point-to-point networks, and mesh networks, which can be seen in Figure 2-11. A broadcast provides one-way communication from a single node. It is called also a beacon. The data is transmitted to any device without creating a link within the range. Contrary to the broadcast, a point-to-point network provides bidirectional communication between the nodes. Every node of a mesh network creates a link

between the adjacent nodes to transform the information through the nodes that are not the destination node. Each network topology is more suitable for different applications and none is superior to the other (Nelson, 2018).



**Figure 2-11** Wireless sensor topologies

Source: (Nelson, 2018).

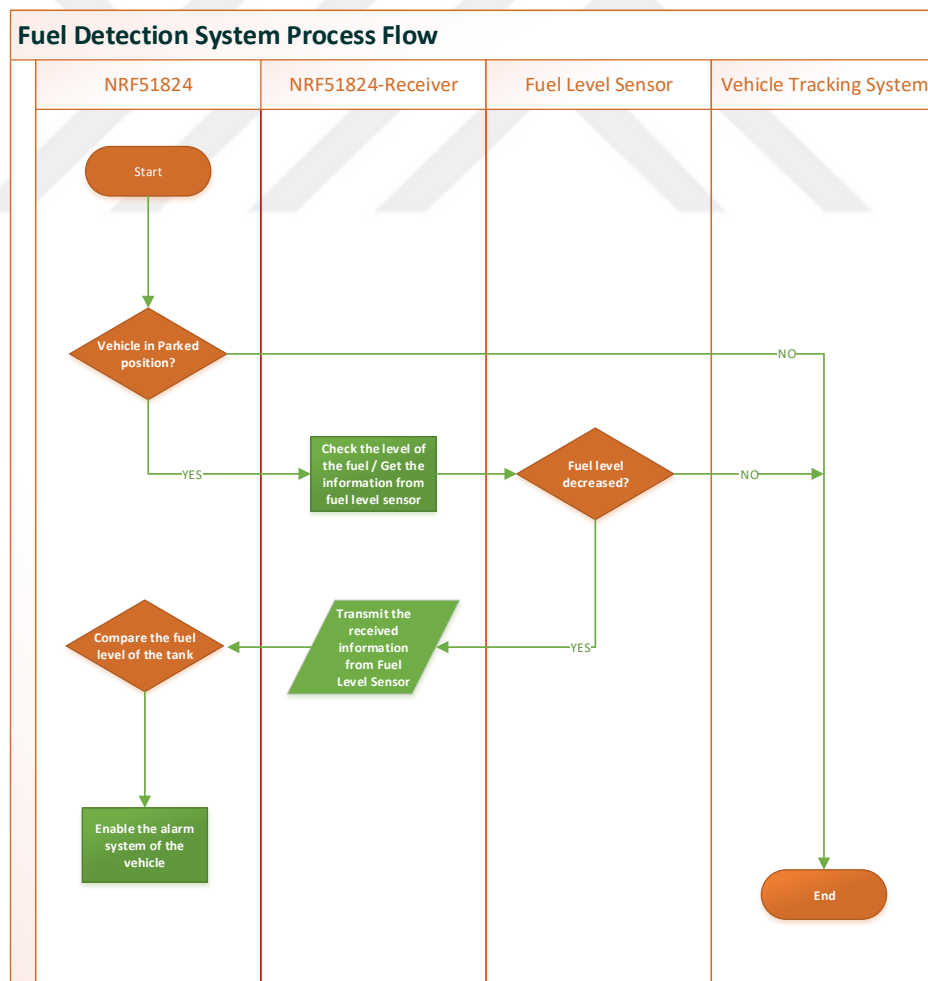
GAP (Generic Access Profile) is responsible to control the Point-to-Point or Broadcast connection of BLE device. It provides the discovery and connection between the devices with a secure platform. To perform the data broadcast, it is needed to a Broadcaster/Observer GAP roles. It is important to notice that BLE is operating on the same bandwidth (2.4 GHz) as classic Bluetooth or WiFi. It has no restriction on the number of broadcasters can listen or broadcast within the bandwidth (Embedded Centric, 2019b).



## CHAPTER 3 MATERIAL AND METHODS

### 3.1 System Overview

The aim is to perform the communication between the system and fuel level sensor by using BLE mechanism. The system is designed and tested to control continuously fuel level against undesirable situations as fuel theft on the parking mode as described in Figure 3-1.



**Figure 3-1** Fuel theft detection process

Three main tasks are satisfied before the evaluation of performance and reliability by statistical analysis. The first task is the installation of the board based on the user's manual. This project is a prototype of the real system and the real system will have many other types of equipment. The application is sufficient to carry out the research. Secondly, the programming of the sensor nodes to gather the information is established. It contains continuously measurement of fuel level information. The aim is to clarify how many times does it take to trigger the alarm system before the discharge of the fuel tank.

## **3.2 Devices and Programs**

Remotely fuel level monitoring is a challenge to prevent undesired fuel tank cap openings. For this reason, a monitoring system realized to gather automatically the necessary data from the fuel tank. The system is proposed with an evaluation board and a fuel level sensor. In this part of the thesis, the characteristics of the devices used during the design are discussed.

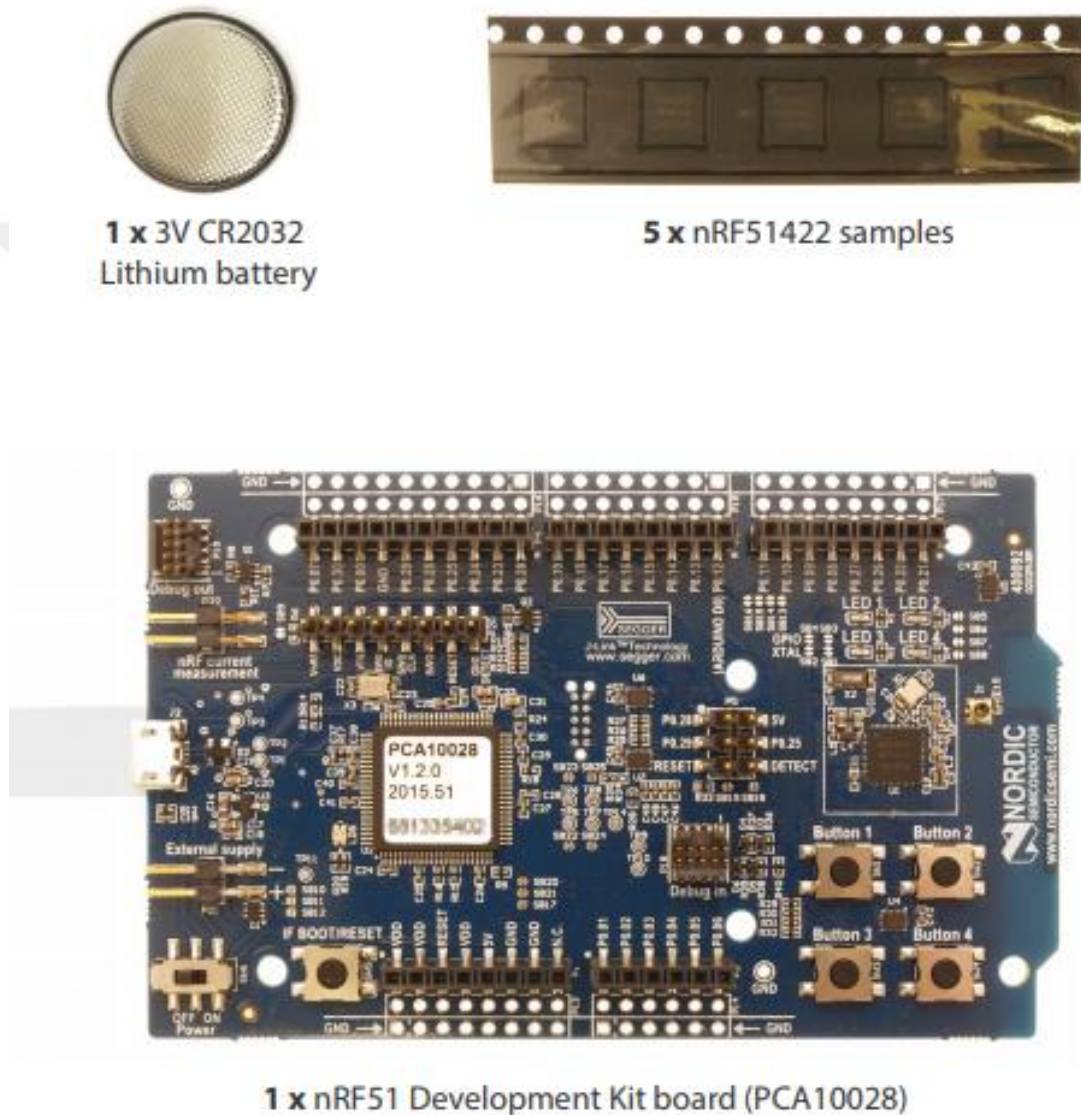
### **3.2.1 NRF51824 – Nordic Semiconductor**

#### **3.2.1.1 nRF51824 Architecture**

nRF51824 based on Nordic semiconductor is used for the application of remote control mechanism. It has a 2.4 GHz operating band with Bluetooth Smart v4.2 wireless protocol (Keeping, 2016). Typically, it is suitable for the automotive industry for BLE connection. It has 2.4 GHz ultra-lower power with a system on a chip (SoC). It gives solutions with AEC Q100 Grade 2 qualification (Nordic Semiconductor, 2017). AEC Q100 called, as “Stress Test Qualification for Integrated Circuits” is an automotive industry qualification. It provides an insight to qualify the electronics of the automotive (Felding, 2017). The standard has five grades numbered from 0 to 4 according to the testing temperature. The temperature range of Grade 2 varies from -40 to 105 °C for aluminum electrolytic capacitors (Lawrie, 2015). Gazell protocol is supported by 2.4 GHz radio. It includes a Programmable Peripheral Interconnect (PPI) system with an analog or digital peripheral without any CPU intervention. The connection of interferences digitally between master/slave and UART performs with flexible GPIOs (Nordic Semiconductor, 2017).

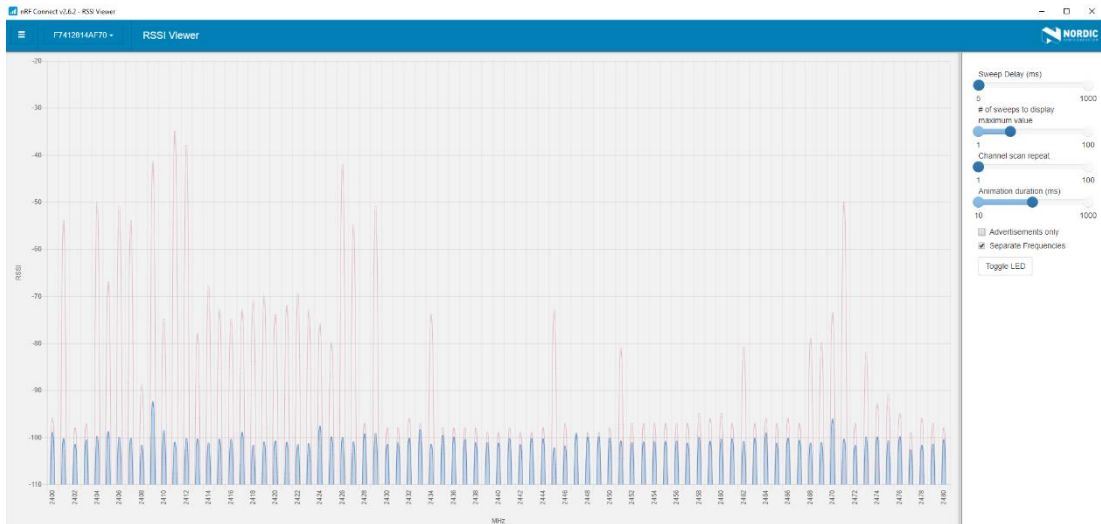
The development kit consists of lithium battery, samples and development kit board which can be seen in Figure 3-2 (Nordic Semiconductor, 2017).

Figure 3-3 and Figure 3-4 demonstrate the nRF chip connection of the channels between 2.4000 GHz to 2.4835 GHz BLE Bandwith (Embedded Centric, 2019a).



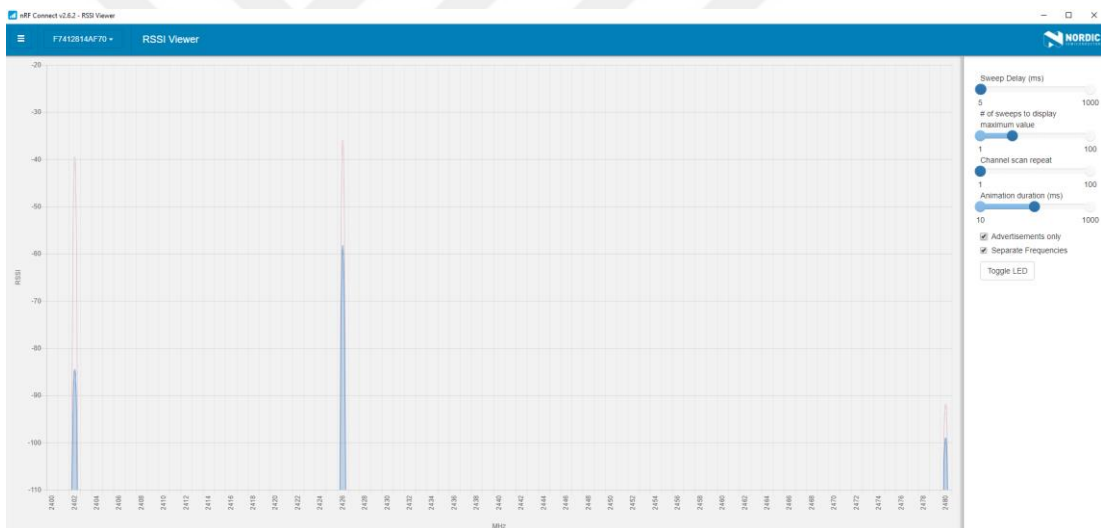
**Figure 3-2** The Development Kit content of the nRF51

Source: (Nordic Semiconductor, 2017)



**Figure 3-3** BLE spectrum captured using nRF connection of 40 channels

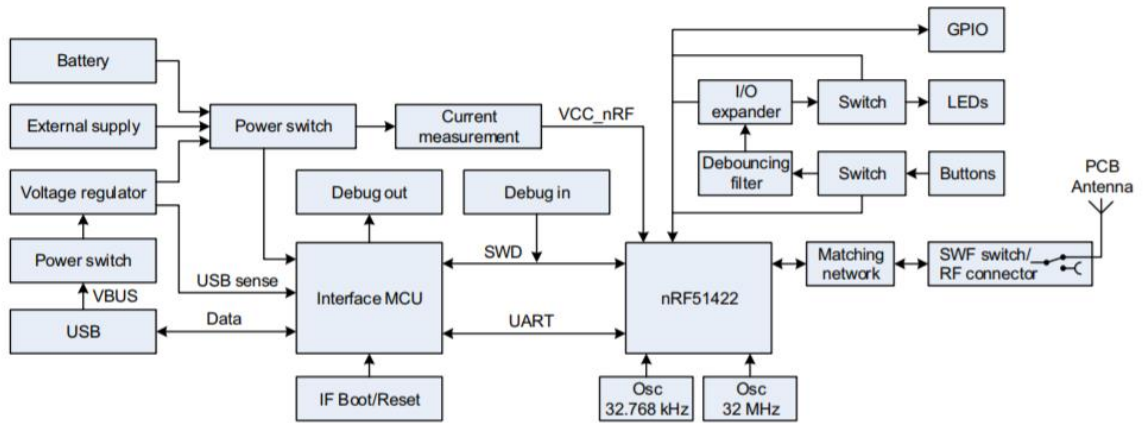
(Source: (Embedded Centric, 2019a).)



**Figure 3-4** BLE spectrum captured using nRF connection with Advertisement channels

(Source: (Embedded Centric, 2019a).)

To use the nRF51824, S110 Soft Device is needed to supply the BLE Peripheral protocol stack by combining low energy controller and host. It is a very useful and flexible API for BLE and SoC (Nordic Semiconductor, 2014a)

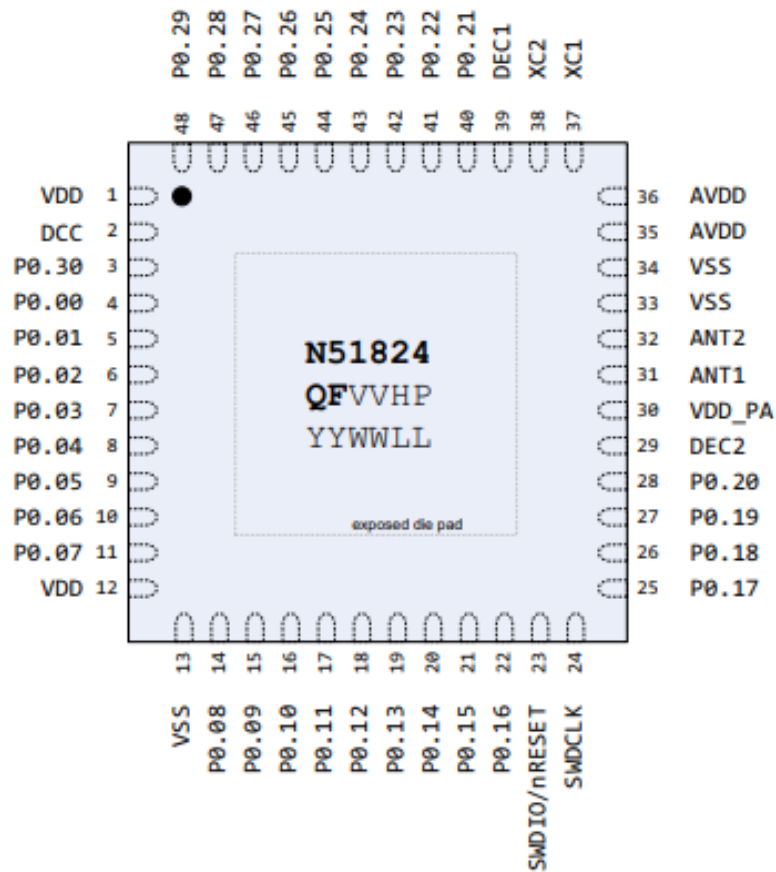


**Figure 6** nRF51 DK board block diagram

**Note:** I/O expander, switches and debouncing filter only valid for DK v1.2.0 and newer.

### Figure 3-5 Block diagram of the sensor

Source: (Nordic Semiconductor, 2015).

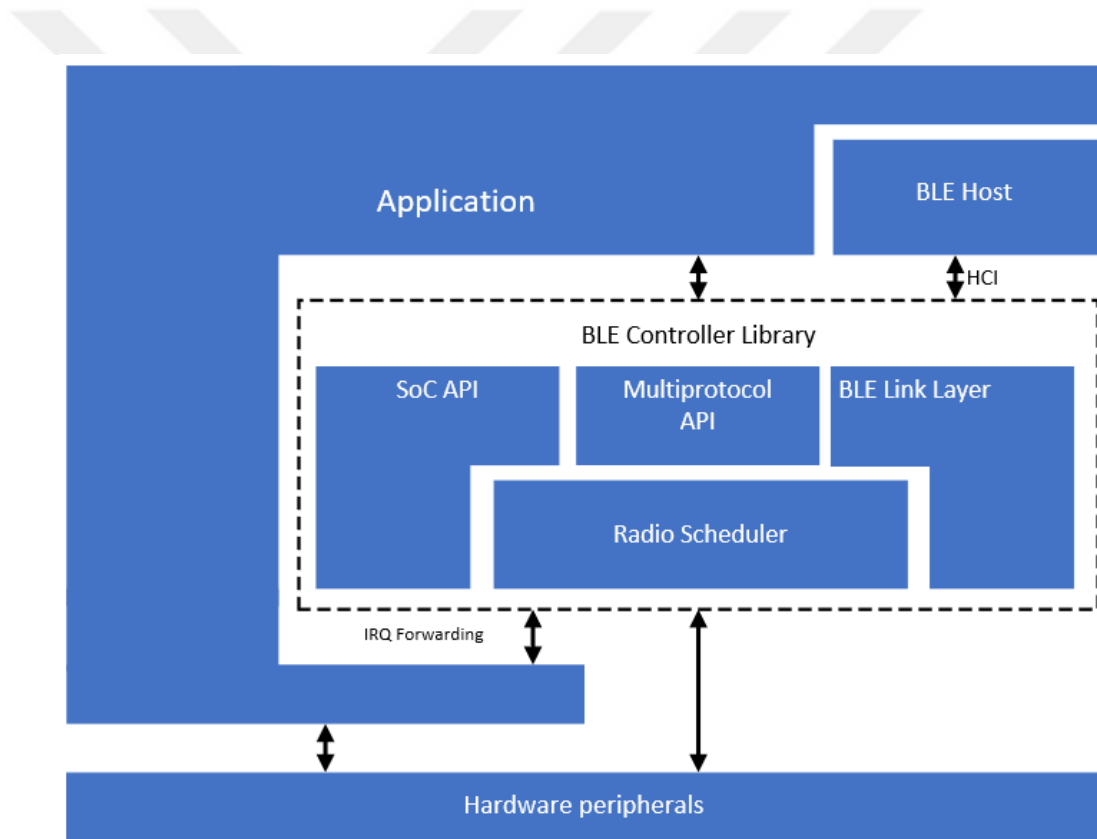


**Figure 3-6** Pin assignment

Source: (Nordic Semiconductor, 2015).

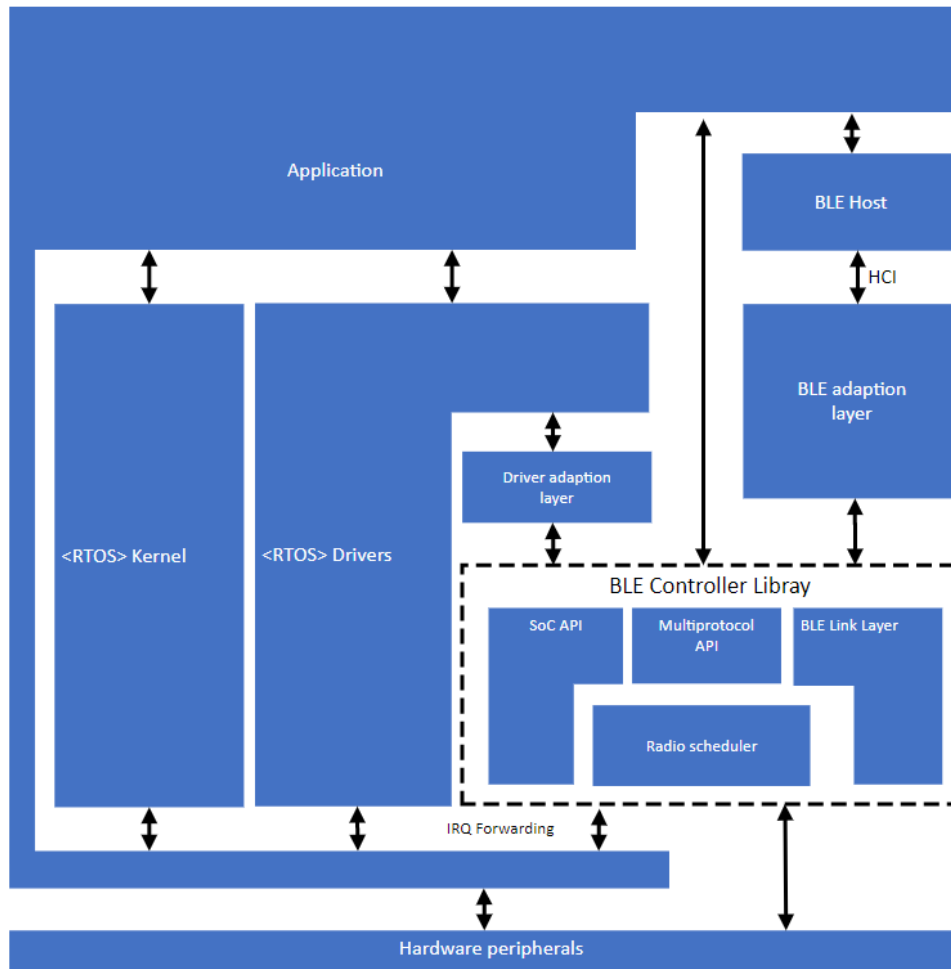
### 3.2.1.2 nRF BLE Controller

The nRF BLE Controller is generated from the Nordic Semiconductor to provide library for nRF52 Series which supports Bluetooth 5. The main responsibility is to provide a BLE HCI interface. In addition, it implements a multiprotocol through APIs to access the flash memory by radioactivity. Figure 3-7 demonstrates the nRF BLE Controller library integration in a real-time operating system (RTOS)-free environment. On the other hand, Figure 3-8 shows the nRF BLE Controller library integration with RTOS. While the BLE Controller Library protocol remains the same, a BLE adoption layer is inserted between the BLE host and BLE Controller library with the integration of RTOS (Nordic Semiconductor, 2018c).



**Figure 3-7** nRF BLE controller architecture diagram for RTOS-free environment

Source: (Nordic Semiconductor, 2018c)

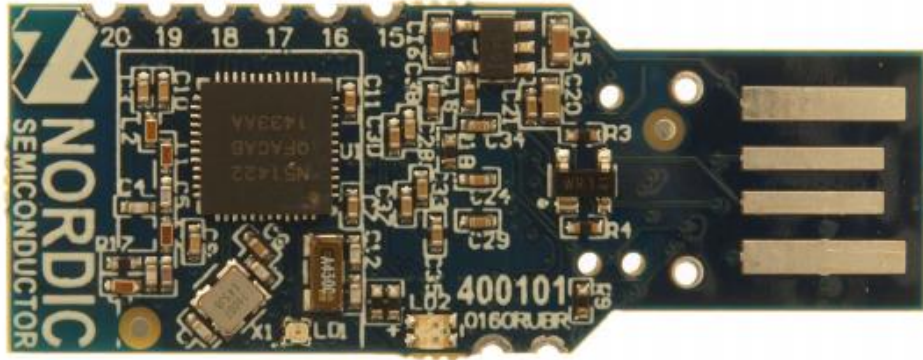


**Figure 3-8** nRF BLE Controller architecture diagram for RTOS

Source: (Nordic Semiconductor, 2018c)

### 3.2.2 nRF51 Dongle

The nRF51 Dongle is with the chip to secure the illegal utilization. Figure 3-9 and Figure 3-10 indicate the Dongle content of the nRF51. At first, the dongle must be connected with the computer. If it has power, the status light will be lightening. The nRF51 Dongle block diagram is in Figure 3-11 (Nordic Semiconductor, 2014b).

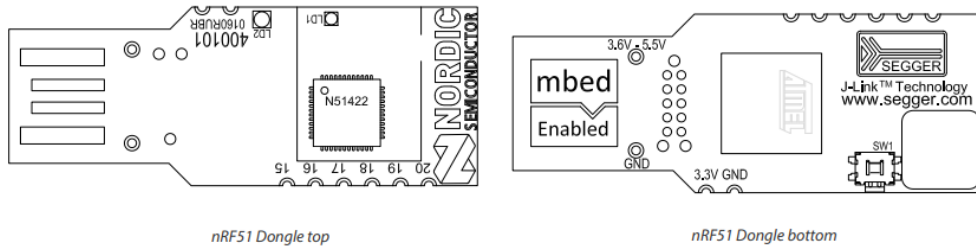


1 x nRF51 Dongle (PCA10031)

**Figure 3-9** nRF51 Dongle content

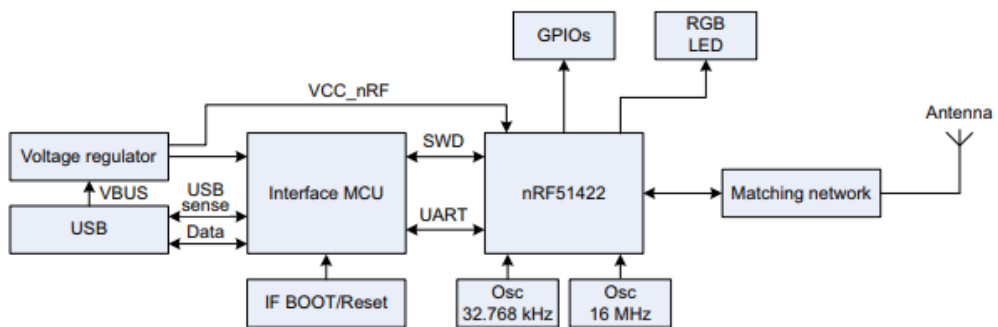
Source: (Nordic Semiconductor, 2014b)

The dongle is the development platform for all the nRF51 devices. It includes the function of onboard programming and debugging. Besides the radio communication tool, it has a feature of communication with a computer through a virtual COM port. This superiority is supported by the interface of the microcontroller. Figure 3-10 shows the dongle top and bottom features. (Nordic Semiconductor, 2014b).



**Figure 3-10** nRF Dongle top and bottom

Source: (Nordic Semiconductor, 2014b)

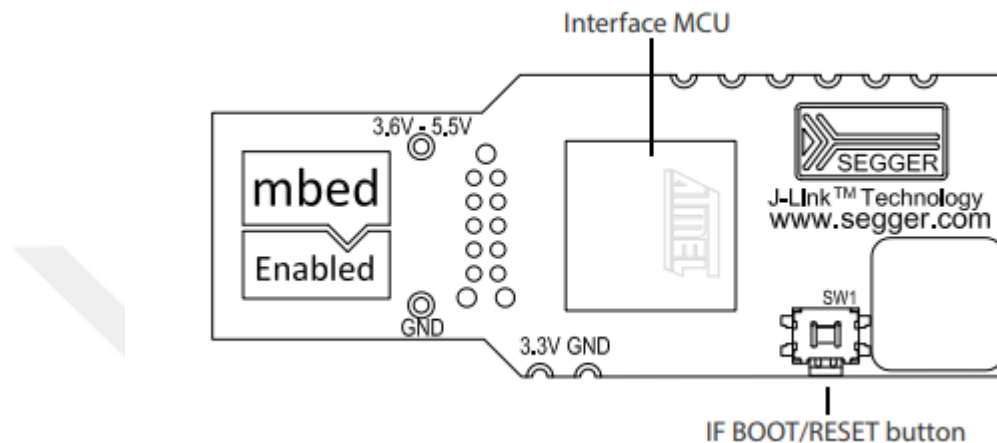


**Figure 3-11** nRF51 Dongle block diagram

Source: (Nordic Semiconductor, 2014b)



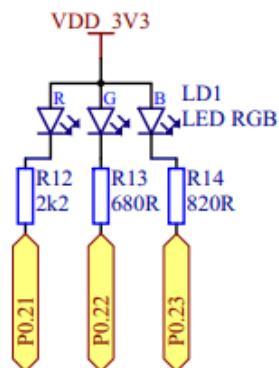
The dongle includes a boot/reset button, which can be seen in Figure 3-12 to connect the interface of the microcontroller. It is mainly responsible for two functions as a reset function for the nRF device and boot loader mode for the interface of microcontroller. During the normal operation, the button plays a role of reset button. To change the function of the button for the boot loader mode, the button must be pressed when the board has power (Nordic Semiconductor, 2014b).



**Figure 3-12** The interface of the microcontroller

Source: (Nordic Semiconductor, 2014b)

A multicolor RGB LED is stored in the dongle. The LED connection is provided by I/Os on the chip. Figure 3-13 indicated the LED configuration of the dongle. P0.21 means the red color, P0.22 signifies the green color and P0.23 denotes the blue color. The illumination of the lights occur by writing the logical zero “0” (Nordic Semiconductor, 2014b)



**Figure 3-13** LED configuration of the dongle

Source: (Nordic Semiconductor, 2014b)

### **3.3 Application Overview**

#### **3.3.1 Developing With the Mdk-Arm Microcontroller Development Kit**

The key features of the nRF51 development kit board supply some parameters as follow (Nordic Semiconductor, 2017).

- nRF51422 flash-based ANT/ANT+, Bluetooth low energy SoC solution
- 2.4 GHz proprietary radio mode compatible with nRF24L series
- Buttons and LEDs for user interaction
- I/O interface for Arduino form factor plug-in modules
- SEGGER J-Link OB Debugger with debug out functionality
- Virtual COM Port interface via UART
- Drag and drop Mass Storage Device (MSD) programming
- mbed enabled

#### **3.3.2 Testing**

##### **3.3.2.1 Test using an Android device**

nRF Blinky Android app is needed to be installed. The app is installed from Google Play and the nRF Blinky GitHub repository (Nordic Semiconductor, 2017).

##### **3.3.2.2 Test using a Central Blinky Client**

Blinky example can be tested by using the BLE Blinky Client Application. The BLE Blinky Client Application Example is central to this peripheral example (Nordic Semiconductor, 2017).

##### **3.3.2.3 Test using nRF Connect**

The application can be tested with nRF connect by applying the instructions given. The first step is based on to compile and program the application. LED 1 must be on position. This indicates that the application is advertising. In addition, the connection to the device from nRF Connect must be observed (the device is advertising as 'Nordic\_Blinky'). When LED 2 is on and LED 1 must be off. This indicates that the connections are established (Nordic Semiconductor, 2017).

#### 3.3.2.4 Blinky

To make the Blinky example, at first it is needed to install the SoftDevice program. It uses the LED Button Server to receive the button modes from nRF development board (Nordic Semiconductor, 2018a).

The Central and Client roles are assigned to GAP and GATT roles, respectively. “Nordic Blinky” is searched by the Blinky Client to make the connection. The responsibility of the Blinky Client is to configure the button characteristics to provide bilateral notifications. The Button notification has a meaning to trigger the LED1 of the Blinky Client board to reflect the status of the button press. If Button 1 is pressing, it is sending the values to the LED characteristics (0x1525). The aim is to stimulate LED1 on the Blinky Server board to reflect the status of the button (Nordic Semiconductor, 2018b).

If Button 1 is connected, it assigns the ON/OFF status into the LED characteristics of the server. For LED assignments, LED 1 indicates the ON status when the scanning process is in progress. LED 2 refers to the ON status when it has a connection and OFF status when it is scanning. In addition, LED 3 demonstrates the ON/OFF notifications from the server if it is connected (Nordic Semiconductor, 2018b).

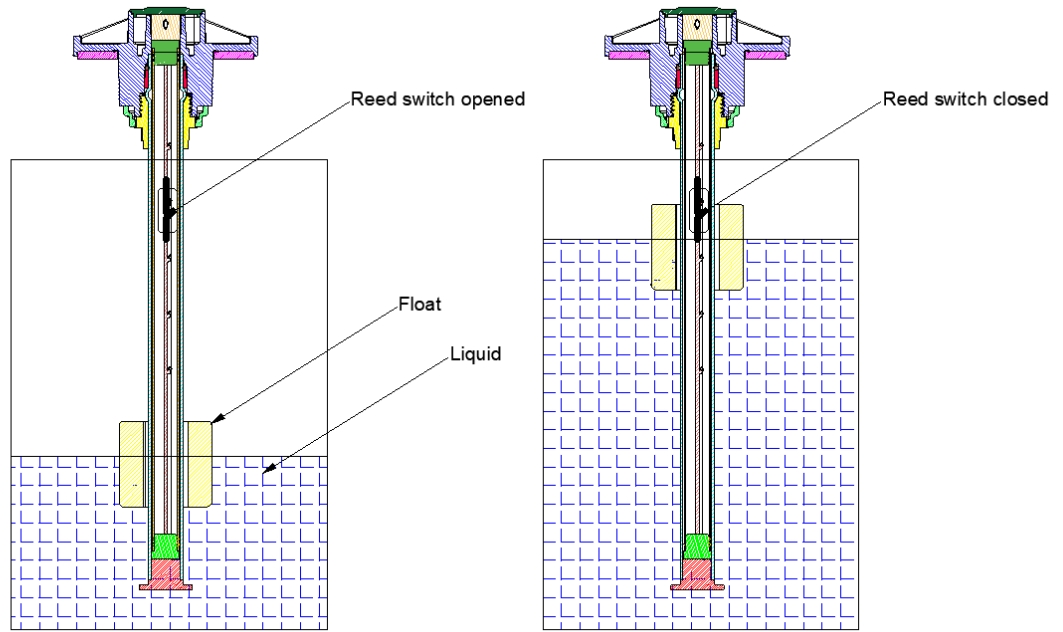
The UART setup settings include a 115.200 of baud rate with 8 data bits and 1 stop bit without parity. After the implementation of the necessary conditions, the test is implemented by using two development board as Client board and Server board. Client board contains the BLE Blinky Client application while Server board includes the BLE Blinky application. To initialize the performance, LED 1 on the Client board must be on status ON. It means that the application implements the scanning process for a Blinky Server. After this situation, the two boards must be connected to each other. In this step, instead of LED 1, LED 2 will be on ON mode. LED 3 on the Server board will be ON status if it is pressed to the Button 1 on the Client board. Concurrently, by pressing the Button 1 on the Server board, the LED 3 on the Client board will be ON mode during the press. The disconnection of the system can be observed by pressing the Reset Button on the Client board (Nordic Semiconductor, 2018b).

### 3.4 Fuel Level Sensor

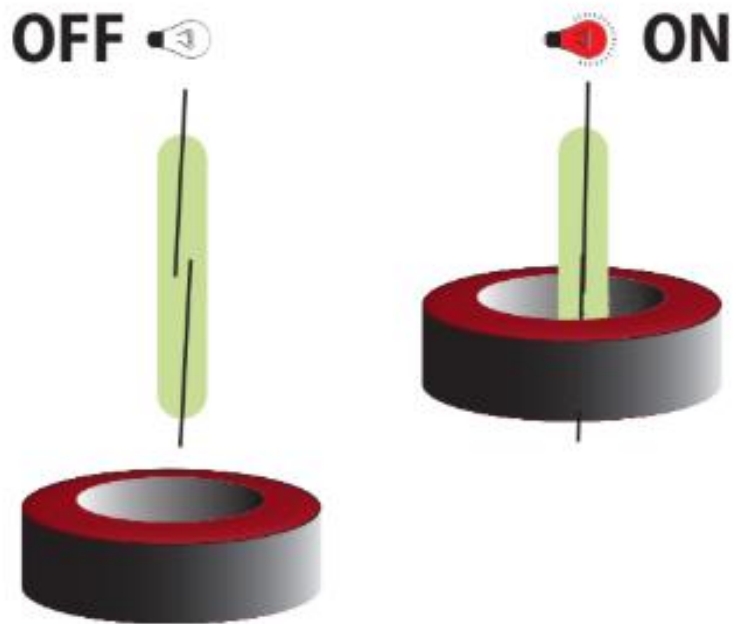
Fuel level sensor is designed for precise measurement in the fuel tank of any type of vehicle in the automotive industry. This sensor can be used as a subsystem of the fuel monitoring system or to prevent diesel fuel losses instead of the existing fuel meter (Apl,2019).

Fuel level sensors provide accurate and reliable data about fuel level in the automotive industry. The fuel level sensor working principle is manufactured based on magnetic field effect. A magnetic magnet is installed to the sensor. The magnet rotary movement is proportional to the float movement (Wekhande and Farakate, 2019). The magnet is mounted on the magnetic float which involves a magnetic reed switch. Usually, the reed switch appends and seals to plastic or non-magnetic metal tube. It includes a ring magnet which is mounted on a float to provide up and down movement based on the liquid level which can be seen in Figure 3-14. The liquid is completely isolated from the electrical system and circuit, thus a healthy and long-lasting level measurement system is established. The magnetic field is formed on the tube where the float ball moves together upward or downward with the liquid. Reed switch placed inside the pipe during the manufacturing process is affected by the magnetic field and change to the electrical value. The obtained electrical value change in accordance with the needs and system of the user. Figure 3-15 demonstrates the reed switch open and closed position depending on the liquid level. If the fuel level is low, then the reed switch open. In contrast, if the fuel level is high, the reed switch will close. The aim to use a ring magnet depends on the magnet sweeping event by the reed switch (Coto Technology, 2016).

Figure 3-16 demonstrates the fuel level sensor technical drawing which is used in this project. BLE wireless sensor is powered by a battery with an operating temperature range between  $-40^{\circ}\text{C}$  and  $+85^{\circ}\text{C}$ . This sensor can be resisted for harsh environmental conditions. BLE wireless sensor sends the gathered data to all BLE compatible devices.



**Figure 3-14** Fuel level sensor working principle

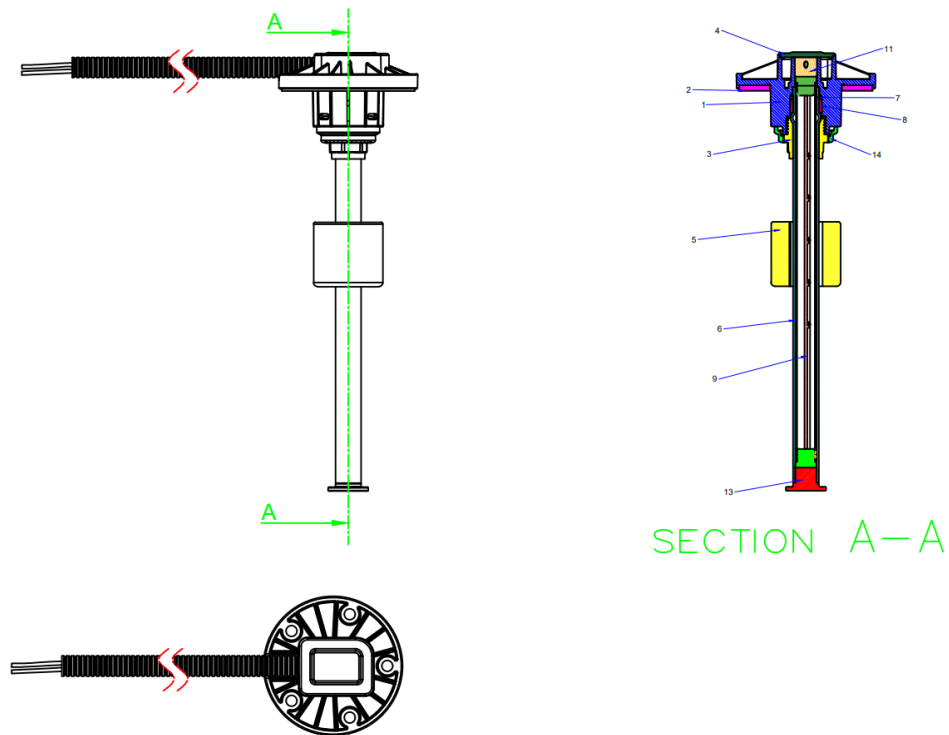


**Figure 3-15** The fuel level sensor ON/OFF mode

Source: (Coto Technology, 2016).

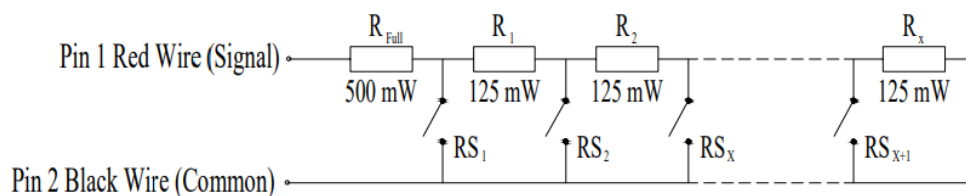
The technical requirements of the sensor can be listed below (Technoton Engineering, 2018, Nesan Otomotiv, 2018).

- The maximum operating voltage is 48 V and the maximum operating current is 100 mA. The application of the circuit can be seen in Figure 3-17.
- If it is mounted properly to the fuel tank, the fuel sender assembly will withstand an internal tank pressure of 10 psi without leakage of air.
- Cable pull-out force is min. 90 N.
- The length of the selected fuel level sensor is 800 mm which can be seen in Figure 3-18. Figure 3-19 expresses the original fuel level sensor.
- Figure 3-20 indicates the installation of the fuel level sensor into the fuel level tank to monitor the liquid level.



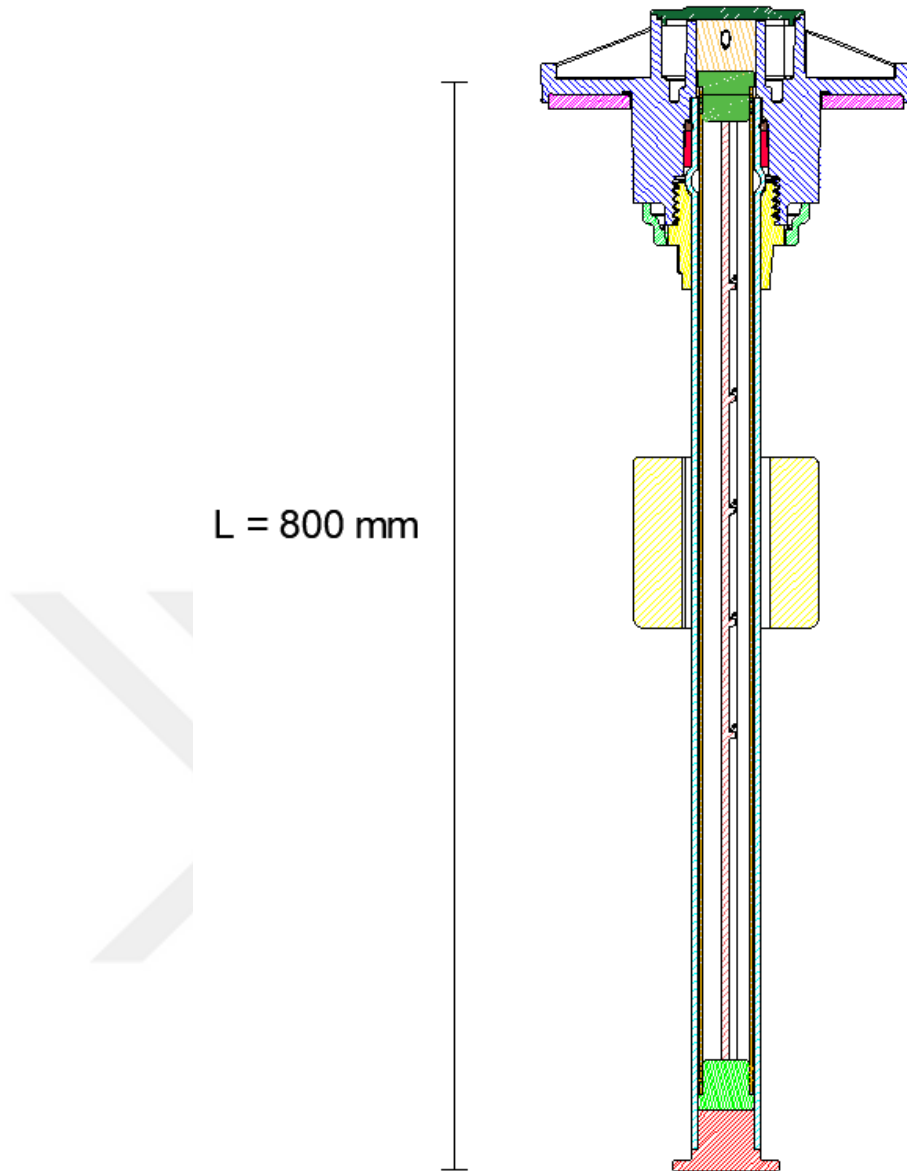
**Figure 3-16** Fuel level sensor on prototype

Source: (Nesan Otomotiv, 2018)



**Figure 3-17** Circuit diagram of the fuel level sensor

Source: (Nesan Otomotiv, 2018)



**Figure 3-18** Fuel level sensor section A-A

Source: (Nesan Otomotiv, 2018)



**Figure 3-19** Fuel level sensor



**Figure 3-20** Installation prototype of the fuel level sensor into the fuel tank

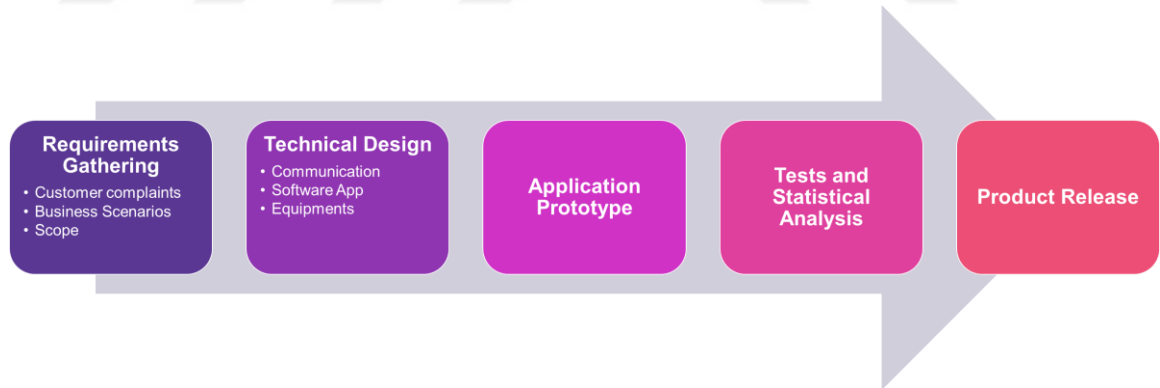
Source: (bTree Technology, 2012)



## CHAPTER 4 APPLICATION

### 4.1 System Modeling

The application modeling is started with gathering the required information according to the customer complaints and business scenarios. The technical design part of the study includes the communication, software and equipment parts. By integrating all the information, an application prototype is released. Before to accomplish a result, tests and statistical analysis are performed. Figure 4-1 shows the product map of the study.



**Figure 4-1** Product map

The system is developed as can be seen in Figure 4-2, Figure 4-3 and Figure 4-4 to simulate the system perspective.

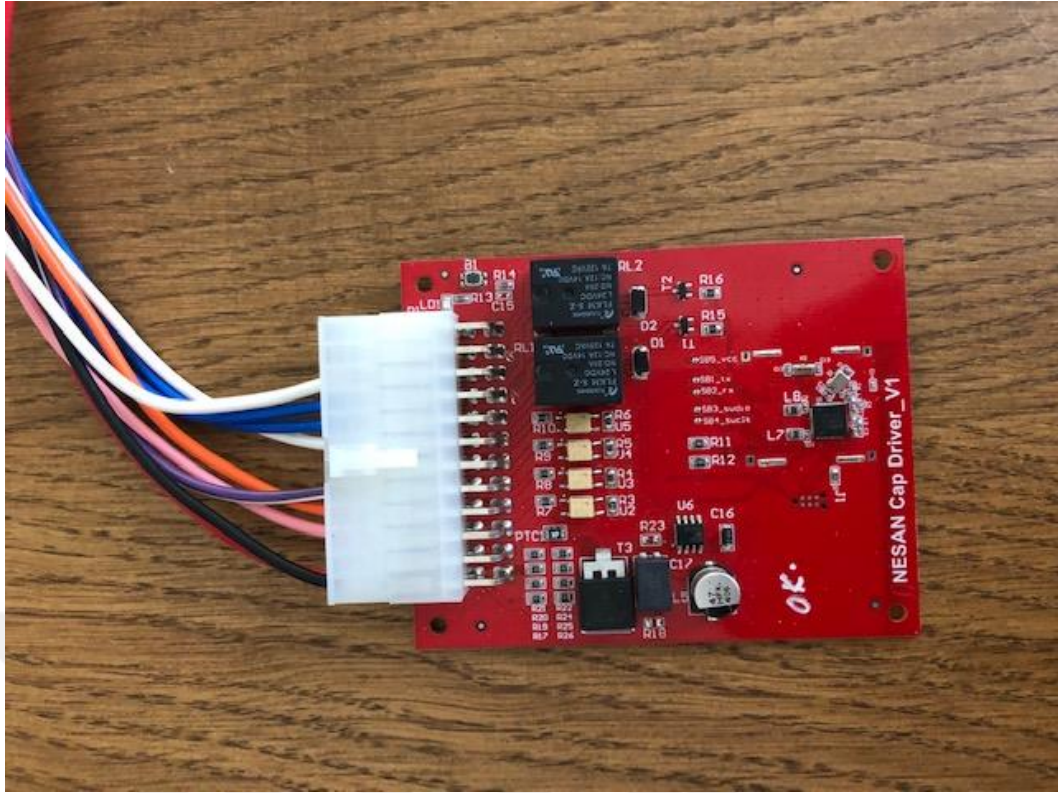


Figure 4-2 Development Kit -top

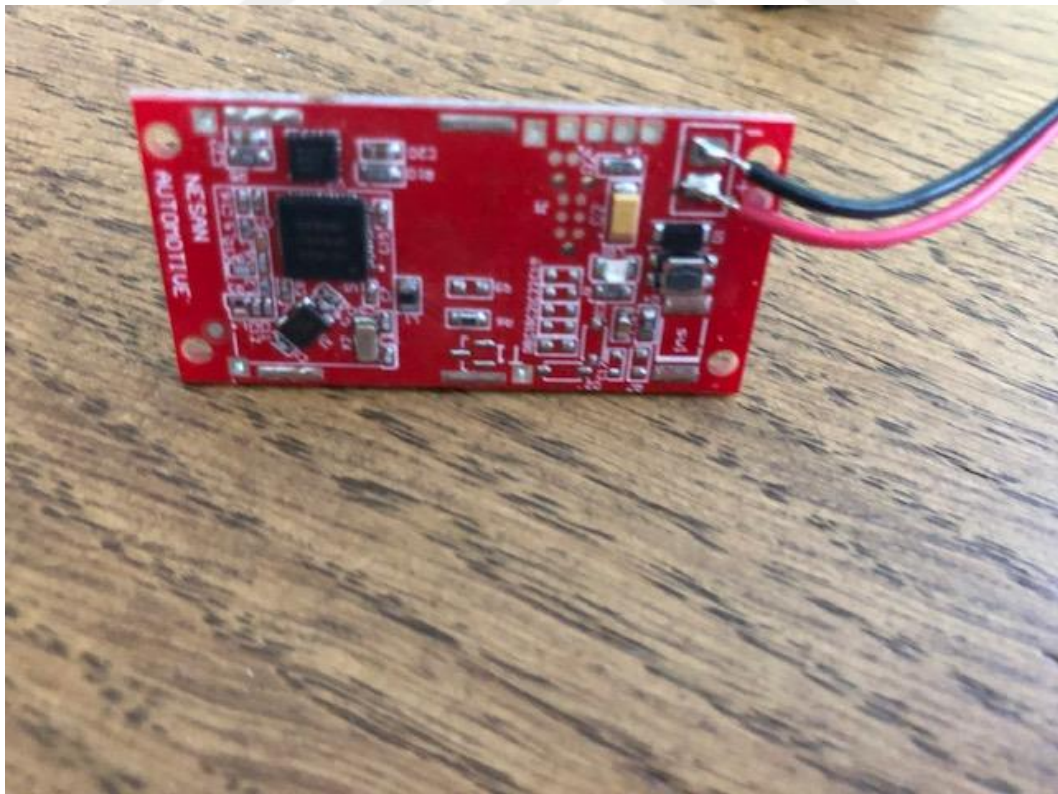
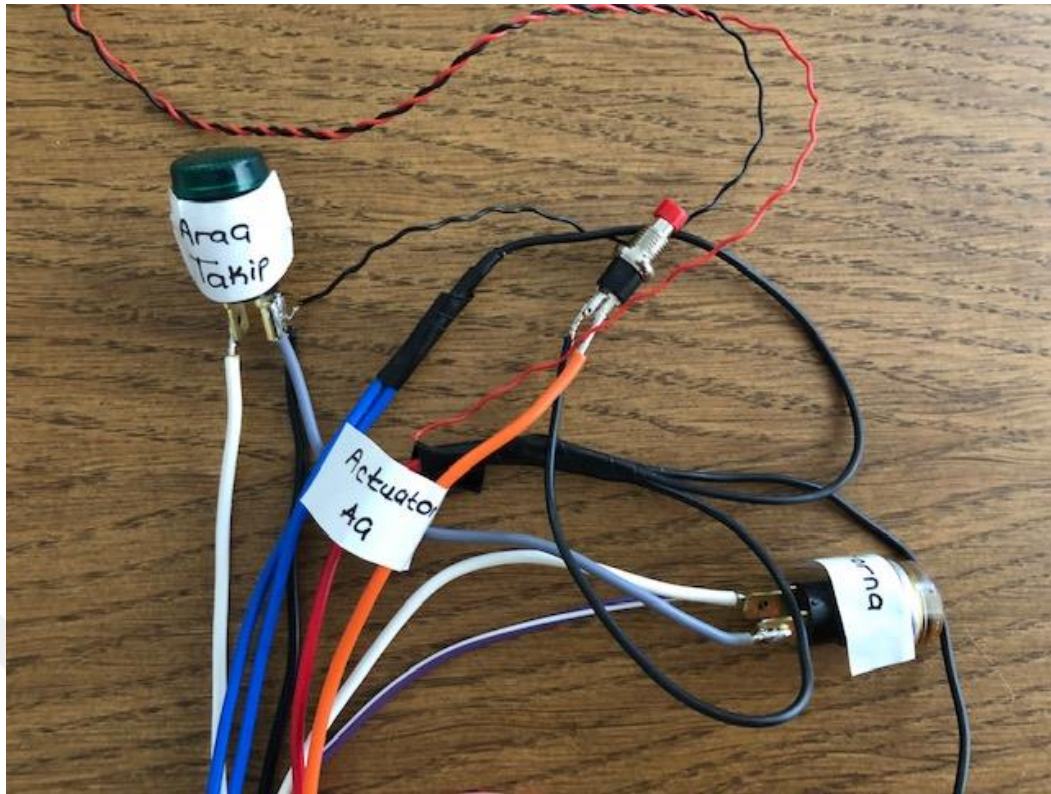
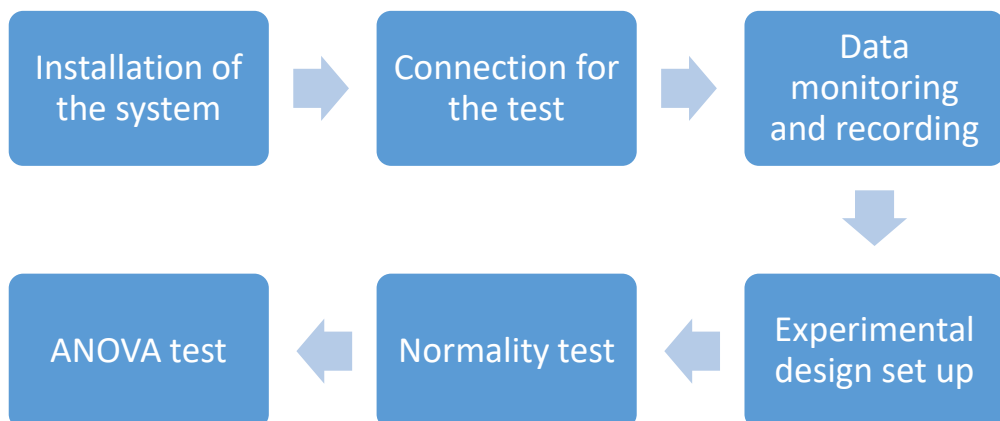


Figure 4-3 Development kit - bottom



**Figure 4-4** Connections

In this chapter, the experimental design was carried out based on the fuel level sensor measurements to make a comparison between the different hole diameters. Figure 4-5 summaries the flow diagram which is followed on this thesis. The system is tested for the communication between nRF fuel level sensor.



**Figure 4-5** Flow diagram of the project

Fuel tank types vary among the truck models. A tank with rectangular geometry is considered to make the analysis which can be seen in Figure 4-6. The volume of the fuel tank is selected 600 L. The dimensions of the tank is designed according to the fuel level sensor height. The experiments were conducted with a height of 800 mm. In respect to stay on the safe side, the tank cannot be fully filled. The height of the tank  $c$  is 0.77 m and the width ( $b$ ) and length ( $a$ ) are 0.624 m and 1.248 m, respectively. The length is twice the size of the width.

$$c = 770 \text{ mm} = 0.77 \text{ m}$$

$$a \times b \times c = 0.6 \text{ m}^3$$

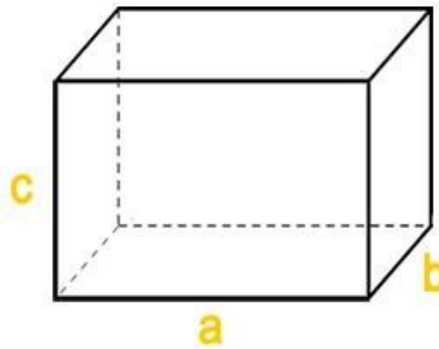
$$a = 2b$$

$$2b \times b \times 0.77 = 1.54 \times b^2 = 0.6 \text{ m}^3$$

$$b = 0.624 \text{ m} = 624 \text{ mm}$$

$$a = 2b = 1.248 \text{ m} = 1248 \text{ mm}$$

$$V = 600 \text{ L}$$



**Figure 4-6** Fuel tank of a commercial truck

The length of the fuel level sensor is 800 mm. The tank is filled with diesel fuel up to the 755 mm, which is the height to fulfill the tank. Three different hole diameter situation is tested as 3 mm, 5mm and 10 mm. This tank leads from a hole of three different diameters to a place of atmospheric pressure. The problem was solved by establishing an algorithm based on the fuel level. According to the flow equation, (Makina Mühendisliğinde Sık Kullanılan Pratik Bilgiler, n.d.)

$$dQ = \sqrt{2gh}C_dA \quad (4.1)$$

$$-S.d.h = \sqrt{2gh}.C_d.A.dt \quad (4.2)$$

$$C_d = 0,61$$

$$\int dt = \frac{1}{\sqrt{2g}.C_d.A} \int_{h_0}^{h_1} (-S \frac{dh.\sqrt{h}}{\sqrt{h}}) \quad (4.3)$$

$$T = \frac{S}{\sqrt{2g}.C_d.A} \int_{h_0}^{h_1} h^{-1/2} dh \quad (4.4)$$

$$T = \frac{S}{\sqrt{2g}C_d.A} \frac{h^{1/2}}{1/2} \quad (4.5)$$

$$T = \frac{S\sqrt{\frac{2}{g}}}{C_d.A} (\sqrt{h_0} - \sqrt{h_1}) \quad (4.6)$$

Here, S is the surface area (axb) and A is the area of the discharge hole ( $\pi D^2/4$ ).  $C_d$  is selected 0,61 according to the shrinkage orifice coefficient.  $h_0$  is the fuel level height of the initial condition which is 770 cm. g is the acceleration of gravity (9.81 m/s<sup>2</sup>). Then, T is the discharge time of the fuel in second. The top hole is opened to the atmosphere and there is a hole in the bottom of the tank to discharge. The question of how much fuel discharge has been investigated for 3 different hole diameter values in 2 minutes. The hole diameters are selected as 3 mm, 5 mm and 10 mm.

#### 4.1.1 3 mm of hole diameter

Calculations and graphics of 3mm of hole diameter are listed below.

$$S = 1.248 m * 0.624 m = 0.77 m^2$$

$$C_d = 0.61$$

$$A = \frac{\pi(D)^2}{4} = \frac{(0.003)^2\pi}{4} = 7.068 * 10^{-6} m^2$$

$$g = 9.81$$

$$h_0 = 0.77 m$$

$$T = 2 \text{ minutes} = 120 \text{ seconds}$$

$$1.49 * 10^{-3} = (\sqrt{0.77} - \sqrt{h_1})$$

$$h_1 = 0.76 \text{ m}$$

$$\text{Volume (V)} = (0.77 - 0.767) \times 0.77 \text{ m}^2 = 2.01 \times 10^{-3} \text{ m}^3 = 2.01 \text{ liter}$$

The total discharge volume in 2 minutes is 2.01 liters. It means that 2.01 liter is discharged from the 600-liter tank in 2 minutes.

#### 4.1.2 5 mm of hole diameter

Calculations of 5 mm of hole diameter are listed below.

$$S = 1.248 \text{ m} \times 0.624 \text{ m} = 0.77 \text{ m}^2$$

$$C_d = 0.61$$

$$A = \frac{\pi(D)^2}{4} = \frac{(0.005)^2 \pi}{4} = 1.96 \times 10^{-5} \text{ m}^2$$

$$g = 9.81$$

$$h_0 = 0.77 \text{ m}$$

$$T = 2 \text{ minutes} = 120 \text{ seconds}$$

$$4.14 \times 10^{-3} = (\sqrt{0.77} - \sqrt{h_1})$$

$$h_1 = 0.763 \text{ m}$$

$$\text{Volume (V)} = (0.77 - 0.763) \times 0.77 \text{ m}^2 = 5.58 \times 10^{-3} \text{ m}^3 = 5.58 \text{ liter}$$

5.58 liter is discharged from the 600-liter tank in 2 minutes.

#### 4.1.3 10 mm of hole diameter

Calculations of 10 mm of hole diameter are listed below.

$$S = 1.248 \text{ m} \times 0.624 \text{ m} = 0.77 \text{ m}^2$$

$$C_d = 0.61$$

$$A = \frac{\pi(D)^2}{4} = \frac{(0.01)^2 \pi}{4} = 7.85 \times 10^{-5} \text{ m}^2$$

$$g = 9.81$$

$$h_0 = 0.77 \text{ m}$$

$$T = 2 \text{ minutes} = 120 \text{ seconds}$$

$$0.0165 = (\sqrt{0.77} - \sqrt{h_1})$$

$$h_1 = 0.74 \text{ m}$$

$$\text{Volume (V)} = (0.77 - 0.74) \times 0.77 \text{ m}^2 = 0.0288 \text{ m}^3 = 28.8 \text{ liter}$$

The total discharge volume in 2 minutes is 28.8 liters from a 600-liter tank.

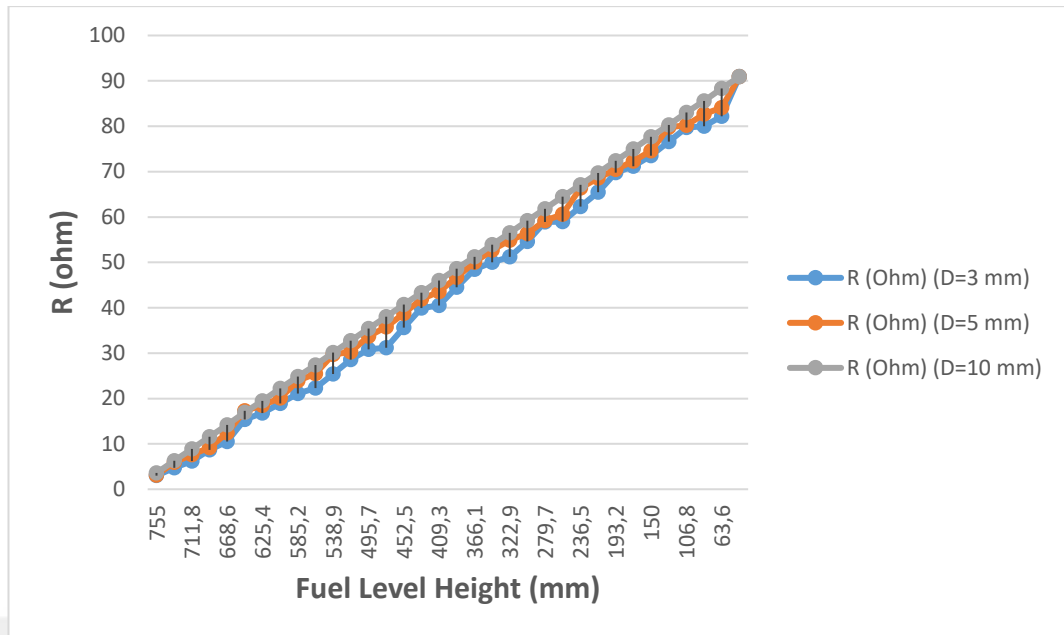
**Table 4-1** Discharge volume of the fuel level according to the hole diameters

<b>D (mm)</b>	<b>V (m<sup>3</sup>)</b>	<b>V (L)</b>
3 mm	2.01 * 10 <sup>-3</sup>	2.01
5 mm	5.58 * 10 <sup>-3</sup>	5.58
10 mm	0.0288	28.8

## 4.2 Statistical Evaluation

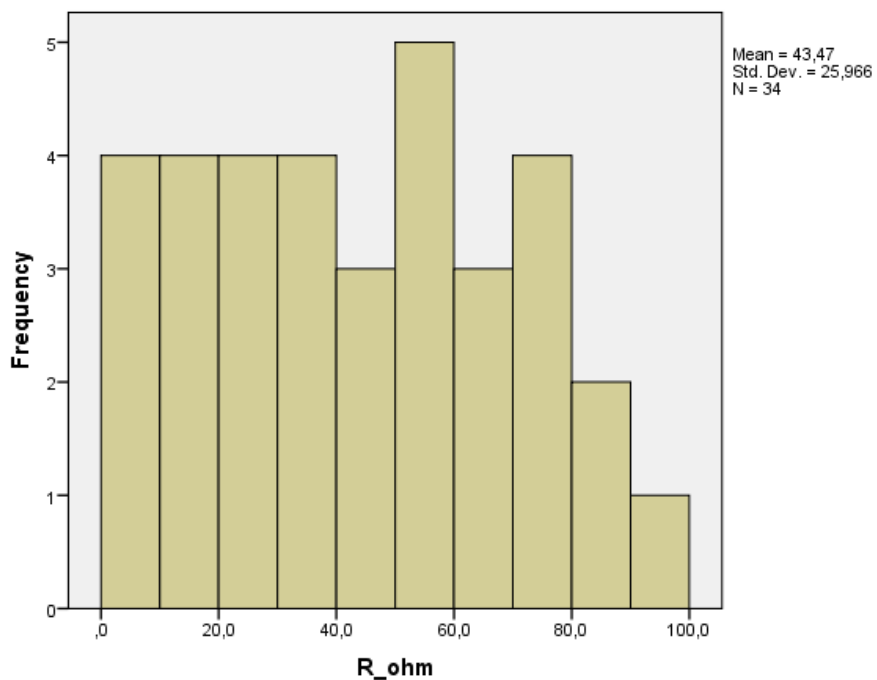
The aim of this section is to understand the test results effects. For this reason, it is focused on the Analysis of Variance (ANOVA) factorial design to understand if the variables are effective by accepting or rejecting the hypothesis. Three diameter holes were selected as variables and the system is tested. Experiments with three-factor one-way factor factorial design were evaluated. There are 3 groups (3 mm, 5 mm and 10 mm of hole diameter) in this study. Therefore, ANOVA is selected to make a comparison between these three groups.

The length of the sensor is 800 mm. Figure 4-7 shows the sensor reading records of fuel level height. 34 trials were examined to find the resistance value. All the currents demonstrate a steady increase with decrease in fuel height level. These values is found out to calculate the current voltage value. This voltage value is important if the current passes through. This voltage value generates the signal in connection with the device.



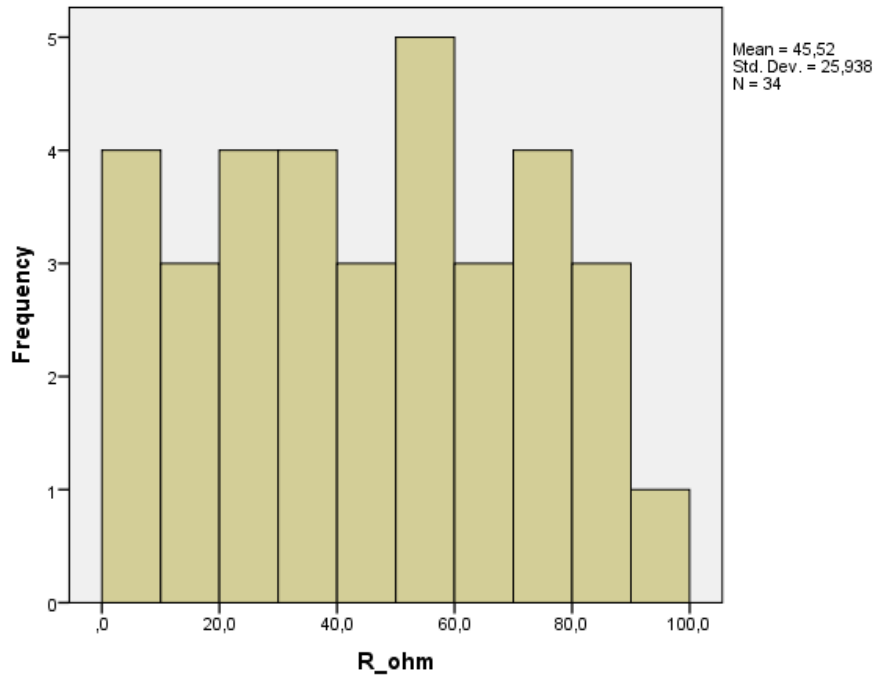
**Figure 4-7** Fuel Level Height – R trends for three different hole diameter

The frequencies of the data can be seen in the histogram plot. It displays the data graphically by using bars. Each bar can demonstrate different heights. Bars splits the data into the intervals, which represents a 10-ohm increment. Figure 4-8, Figure 4-9 and Figure 4-10 show the histogram plots. These plots indicate in which the current range are clustered at most.

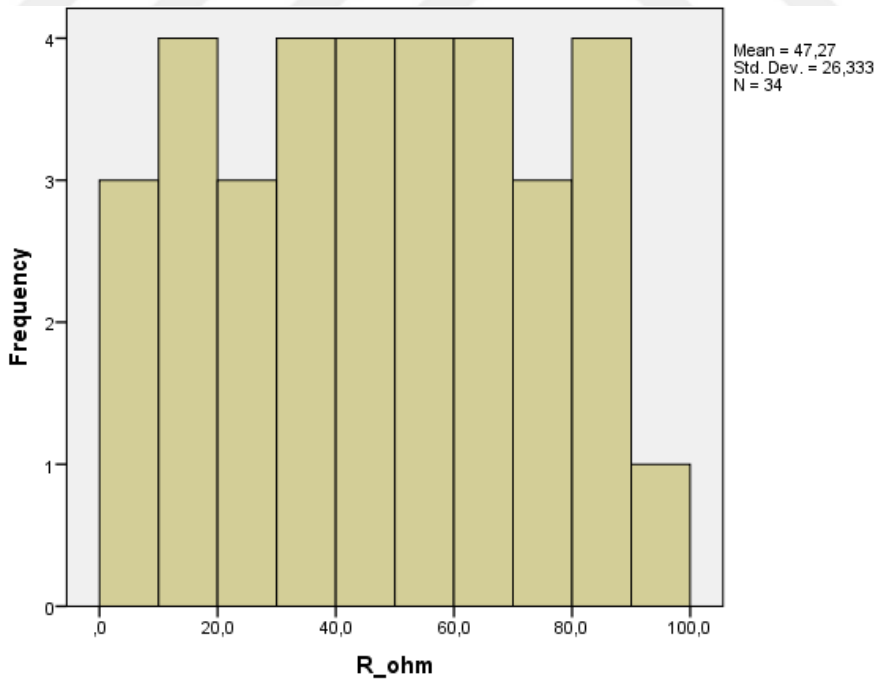


**Figure 4-8** Histogram for D=3 mm





**Figure 4-9** Histogram for D=5 mm



**Figure 4-10** Histogram for D=10 mm

#### 4.2.1 Test of Normality

To examine statistically meaning of the test results and to compare the differences between the groups, One Way ANOVA method is selected among the statistical approaches. There are two basic assumptions in one way analysis of variance. Each group must be normally distributed and the variances of the groups must be homogenous (İset, 2014, SPSS: Test of Normality).

In this dataset, the current conditions of the fuel level sensor are given for 3 different tank hole diameters. To test the normality of these 3 different groups, first of all, hypotheses should be established (İset, 2014, SPSS: Test of Normality).

A hypothesis test begins with two types of hypotheses: Zero hypothesis (null hypothesis) ( $H_0$ ) and Alternative hypothesis ( $H_1$ ). The purpose of a hypothesis test is to decide whether to reject the null hypothesis or not. Zero hypothesis demonstrates that there is no statistically significant difference in the predetermined value of the parameter is expected. An alternative hypothesis is the opposite of the zero hypothesis (Çelik, 2012).

$H_0$  = The data is normally distributed with 95% of the confidence interval.

$H_1$  = The data is not normally distributed with 95% of the confidence interval.

To make the normality test, SPSS package program is used. “Kolmogorov-Smirnov” and “Shapiro-Wilk” tests were evaluated to test the normality. The results can be seen in Table 4-2. Here, the significance (Sig.) values are important to make an analysis. If these values are greater than 0.05,  $H_0$  hypothesis will be accepted. It means that the data is normally distributed with 95% of confidence interval. So, ANOVA test can be used to make a comparison between the groups.

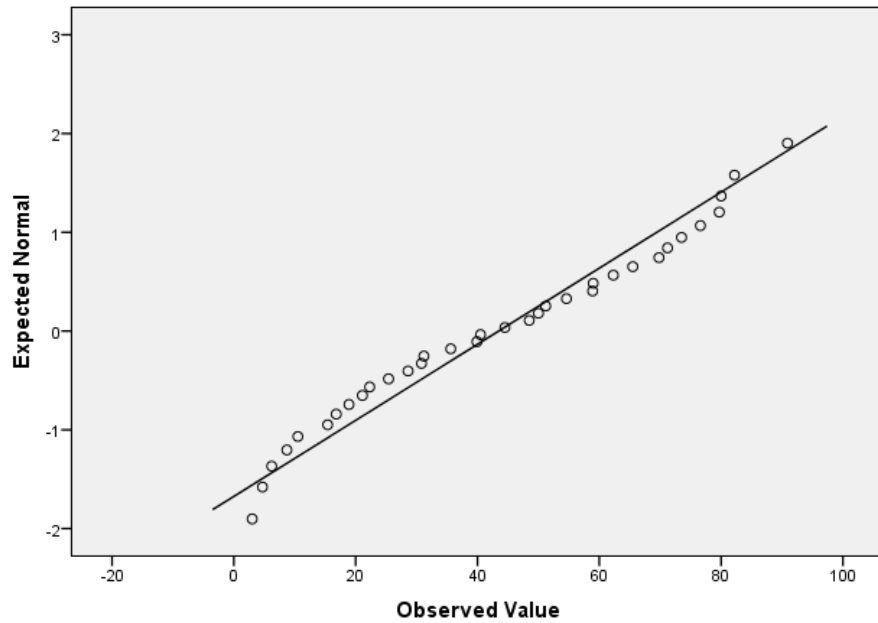
**Table 4-2** Test of Normality

Tests of Normality							
	H	Kolmogorov-Smirnov <sup>a</sup>			Shapiro-Wilk		
		Statistic	df	Sig.	Statistic	df	Sig.
R_ohm	R=3	,094	34	,200*	,954	34	,162
	R=5	,084	34	,200*	,957	34	,205
	R=10	,069	34	,200*	,957	34	,198

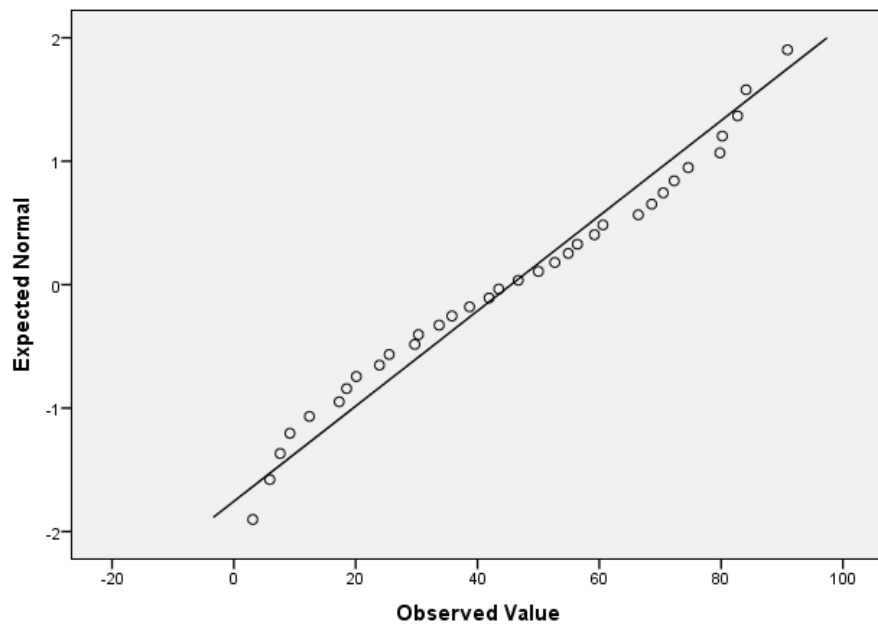
\*. This is a lower bound of the true significance.

a. Lilliefors Significance Correction

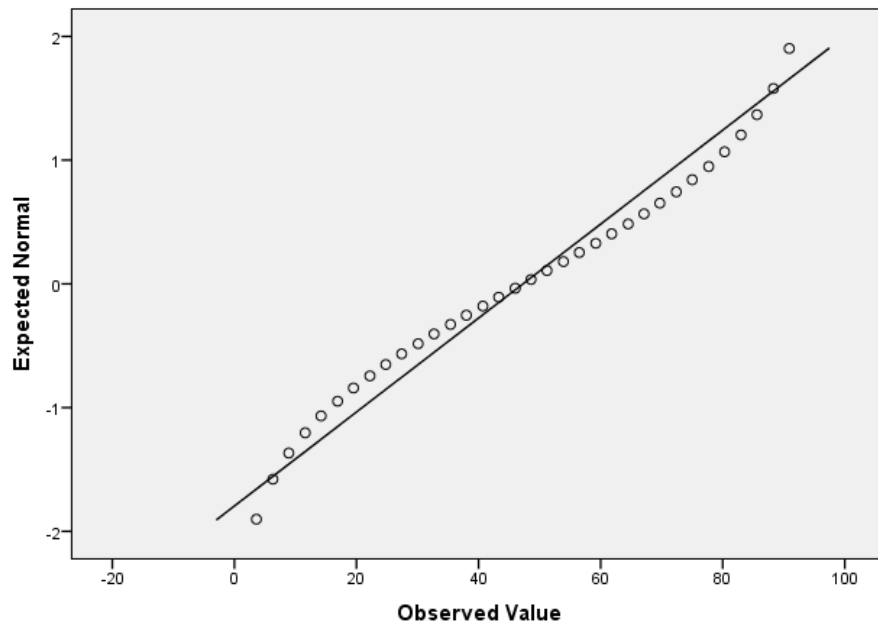
A Q-Q (quantile-quantile) plot is created to quantify the distribution of the variable. If the selected variable matches the test distribution, here it is selected the normal distribution, the points are clustered around a straight line. Figure 4-11, Figure 4-12 and Figure 4-13 present the Q-Q plots for 3 mm, 5 mm and 10 mm hole diameter, respectively (IBM Knowledge Center, 2019).



**Figure 4-11** Normal Q-Q plot for 3 mm hole diameter



**Figure 4-12** Normal Q-Q plot for 5 mm hole diameter



**Figure 4-13** Normal Q-Q plot for 10 mm hole diameter

#### 4.2.2 ANOVA Experimental Design

The prediction of optimum condition between three holes as 3 mm, 5 mm and 10 mm to start the fastest connection of BLE wanted to describe (Hossain et al., 2019). It helps to make decisions by comparing the variables of the process parameters (Naik and Reddy, 2018). It is a method used to test if there is a statistical difference between three or more group means. To conduct ANOVA, the results must be normally distributed. For this reason, the normality test was evaluated before ANOVA test implementation (Çelik, 2012).

The data set shows the variation of fuel height and currents. Here "current" is the dependent variable and "height" is the factor. The height and current values have a normal distribution, which is done in the section above. Therefore, the most appropriate test to compare the mean values of the current values is a one-way analysis of variance. First, hypotheses should be established. The hypothesis to test the homogeneity and one-way ANOVA are predicted as follows (İset, 2014, SPSS: One Way ANOVA).

Hypothesis for testing homogeneity of variances:

$H_0$  = The group variances are homogeneous with 95% of the confidence interval.

$H_1$  = The group variances are not homogeneous with 95% of the confidence interval.

Hypothesis for one-way analysis of variance:

$H_0$  = There is no statistically significant difference between the means of the groups with 95% of the confidence interval.

$H_1$  = There is a statistically significant difference between the means of the groups with 95% of the confidence interval.

ANOVA is used to analyze how independent variables interact among themselves and the effects of these interactions on the dependent variable. The significance level is chosen by  $\alpha=5\%$  (0.05). It means that the results have 95% chance of being true and have a 5% chance for being false. The SPSS results represent 95% confidence intervals.

Here, the height of the fuel level is selected as independent variable and R (ohm) is a dependent variable. If, Table 4-3 is examined which indicates the descriptive statistics; mean and standard deviation of the model. It summarizes the data meaningful. The first column demonstrates the dependent variable names. The second column, N, shows the test size which is 34 for each test. The following columns express the mean and standard deviation for different hole diameter data set. Last columns signify the maximum and minimum values of each test. It can be seen from the table that the highest mean is 47,274 with a 10 mm hole diameter.

**Table 4-3** Descriptive statistics

	N	Mean	Std. Deviation	Std. Error	95% Confidence Interval for Mean		Minimum	Maximum
					Lower Bound	Upper Bound		
					R=3	34		
R=5	34	45,521	25,9377	4,4483	36,471	54,571	3,1	90,9
R=10	34	47,274	26,3331	4,5161	38,085	56,462	3,6	90,9
Total	102	45,422	25,8673	2,5612	40,341	50,502	3,0	90,9

Table 4-4 expresses the test of homogeneity of variances. Since the significance (Sig.) value is 0.995 which is greater than 0.05,  $H_0$  hypothesis is accepted for homogeneity test. For this reason, it can be said that the group variances are homogenous with 95% of confidence.

**Table 4-4** Test of Homogeneity of Variances

Levene Statistic	df1	df2	Sig.
,005	2	99	,995

Table 4-5 examined the ANOVA results. (Information and Computing Science Lecture Notes, 2019). The significance value (Sig.) 0.835 is greater than 0.05, so  $H_0$  hypothesis for one-way analysis of variances is accepted. It means that there is no statistically significant differences between the means of the current which constitutes from different hole diameters.

**Table 4-5** ANOVA

	Sum of Squares	df	Mean Square	F	Sig.
Between Groups	246,360	2	123,180	,181	,835
Within Groups	67334,292	99	680,144		
Total	67580,653	101			

These results suggest that the drilled hole diameter for fuel theft has not an effect to constitute the current. The current is occurred in each hole diameter.

## **CHAPTER 5**

### **CONCLUSION**

In today's technology, wireless communication devices with Bluetooth have started to take an important part of daily lives and are creating new market trends. At this point, researches are made about the low power consumption of the devices, fast and secure communication. Bluetooth Low Energy (BLE) or also known Bluetooth Smart ensures low-energy and low-cost solution for the Internet of Things (IoT) and is developing day by day.

Nowadays, in-vehicle electronics technology is becoming essential with respect to customer needs. According to claim report results of one of the reputable automotive manufacturers indicates that, the crucial expectation of prospects and customers is to have safety electronic systems and following up the status of the car remotely. Due to this reason consumer electronics and internet of things (IoT) technologies are depending on the assessment of needs. In order to follow up status of car remotely, Bluetooth Low Energy technology (BLE) and acceleration sensors are widely used in vehicle electronics.

BLE technology is attracting attention on wireless sensor applications with a connection of a mobile phone. The new technology Bluetooth 5.0 is much faster than the previous versions, with a wide range of domains, battery-friendly and compatible with future technologies. The impact area of Bluetooth Smart has increased and thus the Internet of Things has reached to a new level. Bluetooth technology is very important for faster and more effective interaction between smart devices. Thanks to the Internet of things, Bluetooth is more common in daily life and provides quality, speed, and battery life.

The aim was to design and test for continuous monitoring of fuel level control mechanisms against undesirable situations. A prototype fuel level control system is implemented using wireless sensor networks via BLE and SMS. The fuel level sensor is placed into the fuel tank to collect the data. Temperature and fuel levels are measured inside the fuel tank. If an abrupt change occurs in the temperature and fuel level, the users are informed via SMS. The current work aims to process data locally, transmitting via Bluetooth Low Energy and reporting the output data. The results/outputs of the system implementation are evaluated statistically with experimental design.

One-way ANOVA was conducted to compare the effect of different hole diameter during the fuel theft. The data set was generated according to the variation of fuel height and currents. "Current" is the dependent variable and "height" is the independent factor. First, the normality test conducted if the data is suitable to perform ANOVA test. The results showed that height and current values have normally distributed and suitable for normal distribution. For this reason, to compare the values, one-way analysis of variance (ANOVA) was implemented. At first, the hypotheses of homogeneity and ANOVA were established. The significance level was chosen as  $\alpha=5\%$  (0.05). It means that the results have 95% chance of being true and have a 5% of for being false. The SPSS results represent 95% confidence intervals. As a result of the ANOVA test, it is obtained that the different hole diameter has the same effect to generate the R (ohm).

There are several steps that should be realized in order to further this project. The connection between the sensor and PC must be improved. To move forward, the factors that affect the processing time to send SMS must be analyzed. The number of experiments with the processing time should be increased. Furthermore, the remote monitoring system which depends on the BLE network should be redesigned in order to make the system more accurate.



## REFERENCES

- Aerd Statistics. 2018. Linear Regression Analysis using SPSS Statistics, <https://statistics.laerd.com/spss-tutorials/linear-regression-using-spss-statistics.php>
- Alam, M.S.U. 2018. “Securing Vehicle Electronic Control Unit (ECU) Communications and Stored Data.” Master Thesis. Queen’s University.
- Alidori, E. (2013). A wireless sensor network architecture for solid waste management. Poster abstract.
- Apl (2019). Yakıt Seviyesi Sensörü – DUT. Retrieved from <http://www.apl.com.tr/dut-e-yak305t-seviye-sensoumlruuml.html>
- Avşaroğlu, F. A. et all. 2010. “Software Requirements Specification Greenhouse Monitoring With Wireless Sensor Network”. Senior Design Project. Middle East Technical University.
- Bal, O. 2015. “Mikroişlemcilerin Bluetooth Üzerinden Güvenli Haberleşmesinin Gerçeklenmesi.” Bachelor Thesis. Istanbul Technical University.
- Baz, M. O. M. 2014. “Use of Inferential Statistics to Design Effective Communication Protocols for Wireless Sensor Networks”. PhD Thesis. University of York.
- Bjarnason, J. 2016. “Evaluation of Bluetooth Low Energy in Agriculture Environments.” Bachelor Thesis. Malmö University.
- bTree Technologies (2012). Fuel Monitoring. Retrieved from <http://btreetechnologies.com/products/gps/btVTS-fuel.html>.
- Coto Technology. 2016. Liquid Level Sensing Using Reed Switch Technoloy, Application Note – AN 1602-1.
- Çağlı, A. S. 2012, “İstatistik 2”, Beykent University lecture notes, Ankara, 21 Mart 2012.
- Çelik, N. 2012. “ANOVA Modellerinde Çarpık Dağılımlar Kullanılarak Dayanıklı İstatistiksel Sonuç Çıkarımı ve Uygulamaları.” Doctoral Thesis. Ankara Üniversitesi.

*DA14585/586 SDK 6 Software Developer's Guide UM-B-080 User Manual*, Dialog Semiconductor, 2018.

Digi-Key's North American Editors. 2016. Bluetooth® Low Energy Design 101: From Chipsets to Protocol Stacks to Modules, 14 July 2016, Retrieved from: <<https://www.digikey.com/en/articles/techzone/2016/jul/bluetooth-low-energy-design-101-from-chipsets-to-protocol-stacks-to-modules>>. ,

Elhesseawy, H. and Riad, L. “Bluetooth Low Energy Industrial Sensor.” Master Thesis. Lund University.

Embedded Centric. (2019a). Introduction to Bluetooth Low Energy/Bluetooth 5. Retrieved from <https://embeddedcentric.com/introduction-to-bluetooth-low-energy-bluetooth-5/>

Embedded Centric. (2019b). Lesson 2 – BLE Profiles, Services, Characteristics, Device Roles and Network Topology. Retrieved from <https://embeddedcentric.com/lesson-2-ble-profiles-services-characteristics-device-roles-and-network-topology/>

Felding, H. “Automotive Test Advances.” Master Thesis. Lund University.

Lawrie, E. from Golledge Electronics (2015). The AEC-Q200 Standard, what does it really mean?. Retrieved from <https://www.golledge.com/news/the-aec-q200-standard-what-does-it-really-mean/>

Garcia, A. C. B. et al. 2011. *Sensor Data Analysis for Equipment Monitoring*. Knowledge and Information Systems 28(2):333-364.

Goundar, J. et al. (2014). Mechatronic design solution for fuel level monitoring using pressure sensor: IEEE Asia Pacific World Conference on Computer Science and Engineering, Nadi, Fiji.

Haithem, E. and Lamiaa, R. 2018. “Bluetooth Low Energy Industrial Sensor.” Master Thesis. Lund University.

Hearndon, S. L. 2016. “An Analysis of Bluetooth Low Energy in the Context of Intermittently Powered Devices.” Master Thesis. Clemson University.

- Hossain, M.O., Rahim, N.A., Aman, M.M. and Selvaraj, J. 2019. *Application of ANOVA method to study solar energy for hydrogen production*. International Journal of Hydrogen Energy. Vol 44 (79): 14571-14579.
- IBM Knowledge Center (2019). Q-Q Çizimi Oluşturma. Retrieved from [https://www.ibm.com/support/knowledgecenter/tr/SSEP7J\\_10.1.1/com.ibm.swg.ba.cognos.ug\\_cr\\_rptstd.10.1.1.doc/t\\_id\\_stat\\_qq.html](https://www.ibm.com/support/knowledgecenter/tr/SSEP7J_10.1.1/com.ibm.swg.ba.cognos.ug_cr_rptstd.10.1.1.doc/t_id_stat_qq.html).
- Information and Computing Science Lecture Notes, Academic Year 2019. Universiteit Utrecht. Retrieved from <http://www.cs.uu.nl/docs/vakken/arm/SPSS/spss4.pdf>.
- İset, Volkan (2014). SPSS: Test of Normality. Retrieved from <http://volkaniset.blogspot.com/p/spsstest-of-normality-normallik-testi.html>.
- İset, Volkan (2014). SPSS: One Way ANOVA. Retrieved from <http://volkaniset.blogspot.com/p/spssone-way-anovatek-yonlu-varyans.html>
- Kambham, N. K. 2018. “Predicting Personality Traits Using Smartphone Sensor Data and App Usage Data.” Master Thesis. University of Saskatchewan.
- Keeping, S. from Nordic Semiconductor (2016, Summer). Ultra low power wireless connectivity solutions. *Ultra Low Power Wireless Quarter 2*, 15-16. Retrieved from [http://freqchina.com/uploads/soft/201611/11\\_09122221.pdf](http://freqchina.com/uploads/soft/201611/11_09122221.pdf)
- Köse, E., Yaşar, E., Yamaçlı, S. 2009. *Dijital Yakıt Seviye, Yol Göstergesi ve Yakıt Güvenlik Sistemin Ağır Vasıta Araçlarına Uygulanması*. Politeknik Dergisi. Vol 12 (1): 7-11.
- Kuchimanchi, S. 2015. “Bluetooth Low Energy Based Ticketing Systems.” Master Thesis. Aalto University.
- Lin, J.-R., Talty, T. and Tonguz, O. K. 2015. *On the Potential of Bluetooth Low Energy Technology for Vehicular Applications*. IEEE Communications Magazine 53 (1).
- Lockfeer, L. 2010. “Encrypted SMS, an analysis of the theoretical necessities and implementation possibilities.” Bachelor Thesis. Radboud University.
- Lonzetta, A. M. et all. 2018. *Security Vulnerabilities in Bluetooth Technology as Used in IoT*. Journal of Sensor and Actuator Networks. Vol. 7 (3): 28.
- Lyatuu, Cornel Andrew. 2018. “An Analysis of Bluetooth 5 Protocol in Comparison to the Preceding Bluetooth Versions”. Master’s Thesis. Kocaeli University.

- Makina Mühendisliğinde Sık Kullanılan Pratik Bilgiler (n.d). Retrieved from (<http://www.muhendislikbilgileri.com/?pnun=129&pt=PROBLEM+4>)
- Naik, A.B. and Reddy, C. *Optimization of tensile strength in TIG welding using the Taguchi method and analysis of variance (ANOVA)*. Thermal Science and Engineering Progress. Vol 8, 327-339.
- Nelson, B. 2018. "A Bluetooth Low-Energy Wireless Sensor Platform for Continuous Monitoring of a Bioreactor Environment during Cell Manufacturing." Master Thesis. Michigan Technological University.
- Nesan Otomotiv A.Ş. Fuel Level Sensor Technical Drawing Sheet, 2018.
- Nordic Semiconductor. (2014a). Creating Bluetooth Low Energy Applications Using nRF51822 Application Note v1.1. Retrieved from [https://infocenter.nordicsemi.com/pdf/nan\\_36.pdf](https://infocenter.nordicsemi.com/pdf/nan_36.pdf).
- Nordic Semiconductor. (2014b). nRF51 Dongle Developing with MDK-ARM Microcontroller Development Kit User Guide v1.0. Retrieved from [https://infocenter.nordicsemi.com/pdf/nRF51\\_Dongle\\_UG\\_v1.0.pdf?cp=4\\_1\\_1](https://infocenter.nordicsemi.com/pdf/nRF51_Dongle_UG_v1.0.pdf?cp=4_1_1).
- Nordic Semiconductor. (2015). nRF51824 Multiprotocol Bluetooth® low energy/2.4 GHz RF System on Chip Product Specification v1.0. Retrieved from: [https://infocenter.nordicsemi.com/pdf/nRF51824\\_PS\\_v1.0.pdf?cp=4\\_3\\_0\\_0](https://infocenter.nordicsemi.com/pdf/nRF51824_PS_v1.0.pdf?cp=4_3_0_0).
- Nordic Semiconductor. (2017). nRF51 Development Kit Developing with MDK-ARM Microcontroller Development Kit User Guide v1.2. Retrieved from [https://infocenter.nordicsemi.com/pdf/nRF51\\_Development\\_Kit\\_User\\_Guide\\_v1.2.pdf](https://infocenter.nordicsemi.com/pdf/nRF51_Development_Kit_User_Guide_v1.2.pdf).
- Nordic Semiconductor. (2018a). BLE Blinky Application. Retrieved from: [https://infocenter.nordicsemi.com/index.jsp?topic=%2Fcom.nordic.infocenter.sdk5.v15.0.0%2Fble\\_sdk\\_app\\_blinky.html&cp=4\\_0\\_0\\_4\\_1\\_2\\_3](https://infocenter.nordicsemi.com/index.jsp?topic=%2Fcom.nordic.infocenter.sdk5.v15.0.0%2Fble_sdk_app_blinky.html&cp=4_0_0_4_1_2_3)
- Nordic Semiconductor. (2018b). BLE Blinky Client Application. Retrieved from: [https://infocenter.nordicsemi.com/index.jsp?topic=%2Fcom.nordic.infocenter.sdk5.v15.0.0%2Fble\\_sdk\\_app\\_blinky\\_c.html](https://infocenter.nordicsemi.com/index.jsp?topic=%2Fcom.nordic.infocenter.sdk5.v15.0.0%2Fble_sdk_app_blinky_c.html)
- Nordic Semiconductor. (2018c). nRF BLE Controller. Retrieved from [http://developer.nordicsemi.com/nRF\\_Connect\\_SDK/doc/1.0.0/nrfxlib/ble\\_controller/doc/README.html](http://developer.nordicsemi.com/nRF_Connect_SDK/doc/1.0.0/nrfxlib/ble_controller/doc/README.html)

- Ohlson, T. 2013. "Digitising statistics handling through hardware and mobile web technology." Master Thesis. Chalmers University of Technology.
- Rasshofer, R. H. 2007. Functional requirements of future automotive radar systems: 2007 European Radar Conference.
- Sarstedt, M and Mooi, E. (2011) *A Concise Guide to Market Research – Chapter 7*. Berlin: Springer
- Senthil, K. R., Ganapathi, M., Arunkamar. D., Goutham, G. and Karthick, M. 2017. *Fuel Monitoring System for Fuel Management*. International Journal of Science, Engineering and Technology Research (IJSETR). Vol 6 (4): 565-571).
- Technoton Engineering. 2018. Fuel Level BLE Wireless Sensor, 20 August 2018, Retrieved from: < <https://rd-technoton.com/fuel-level-ble-wireless-sensor.html>>.
- Tonta, Y. 2008, "Varyans Analizi", Hacettepe University lecture notes, Ankara.
- Warwickshire Police, n.d. Retrieved from [https://www.westmercia.police.uk/media/5830/Fuel-theft-advice-sheet/pdf/Fuel\\_Theft\\_Advice\\_Sheet.pdf](https://www.westmercia.police.uk/media/5830/Fuel-theft-advice-sheet/pdf/Fuel_Theft_Advice_Sheet.pdf)
- Wekhande, S. and Farakate, R. 2019, "Fuel Level Sensor Using Hall-Effect Sensor ICs", Application Information, Allegro Microsystems
- Winkel, T.T.L. 2016. "Robustness of bluetooth low energy in in-vehicle networks." Master Thesis. Eindhoven University of Technology.