

AN EXAMINATION OF WORK-FAMILY CONFLICT FROM THE
SELF-DETERMINATION THEORY PERSPECTIVE

A THESIS SUBMITTED TO THE GRADUATE SCHOOL OF SOCIAL
SCIENCES OF MIDDLE EAST TECHNICAL UNIVERSITY

BY

ASLI YALÇIN

IN PARTIAL FULFILLMENT OF THE REQUIREMENTS
FOR
THE DEGREE OF DOCTOR OF PHILOSOPHY
IN
THE DEPARTMENT OF PSYCHOLOGY

OCTOBER 2017

Approval of the Graduate School of Social Sciences

Prof. Dr. Tülin Gençöz
Director

I certify that this thesis satisfies all the requirements as a thesis for the degree of
Doctor of Philosophy.

Prof. Dr. Canan Sümer
Head of Department

This is to certify that we have read this thesis and that in our opinion it is fully
adequate, in scope and quality, as a thesis for the degree of Doctor of Philosophy.

Prof. Dr. Reyhan Bilgiç
Supervisor

Examining Committee Members

Assoc. Prof. Dr. Türker Özkan (METU, PSY) _____

Prof. Dr. Reyhan Bilgiç (METU, PSY) _____

Assoc. Prof. Dr. Pınar Acar (METU, BA) _____

Asst. Prof. Dr. A. Başak Ok (Ankara Üni., PSİ) _____

Asst. Prof. Dr. Ayça Özen Çıplak (TOBB ETÜ., PSİ) _____



I hereby declare that all information in this document has been obtained and presented in accordance with academic rules and ethical conduct. I also declare that, as required by these rules and ethical conduct, I have fully cited and referenced all material and results that are not original to this work.

Name, Surname: Aslı Yalçın

Signature :

ABSTRACT

AN EXAMINATION OF WORK-FAMILY CONFLICT FROM THE SELF- DETERMINATION THEORY PERSPECTIVE

Yalçın, Aslı

Ph.D., Department of Psychology

Supervisor: Prof. Dr. Reyhan Bilgiç

October, 2017, 232 pages

The current study was designed for two main purposes: first, to explore the motivational underpinnings of work-family conflict by utilizing Self-Determination Theory (SDT; Deci & Ryan, 1985, 2000), and second, to propose an integrative model involving both antecedents of work and family motivation (job characteristics, work support, spousal support, perceived control at home) and the basic consequences of work-family conflict (job satisfaction, job-related emotional exhaustion, family satisfaction, family-related emotional exhaustion, and life satisfaction). Exploring the moderating effects of work/family role identifications on the relationships between work-family conflict dimensions (W-to-FC and F-to-WC) and satisfaction outcomes was also another aim of the study. To accomplish these purposes, the study was undertaken in two stages. First, a pilot study was conducted to evaluate factorial structures and internal consistency of the study measures on 407 dual earner couples with at least one child younger than 18 years old. After confirming that scales had adequate psychometric properties, the main study was conducted to test the hypothesized relationships and associations proposed in the model. Analyses conducted on 405 dual earner couples with at least one child younger than 18 years old generally supported the proposed links. As expected,

autonomous motivation toward work negatively predicted W-to-FC and autonomous motivation toward family negatively predicted F-to-WC. However, contrary to predictions, no interactive effects of motivation toward work and motivation toward family were found. Results were also insignificant with respect to the associations between work-family conflict dimensions and satisfaction outcomes. Findings were discussed, and the contributions and practical implications of the study were presented.

Keywords: work-family conflict, self-determination, motivation, satisfaction, exhaustion

ÖZ

İŞ-AİLE ÇATIŞMASININ ÖZ-BELİRLEME KURAMI ÇERÇEVESİNDE İNCELENMESİ

Yalçın, Aslı

Doktora, Psikoloji Bölümü

Danışman: Prof. Dr. Reyhan Bilgiç

Ekim, 2017, 232 sayfa

Bu çalışmanın iki temel amacı bulunmaktadır. Bunlardan ilki, Öz-Belirleme Kuramı'ndan (ÖBK; Deci & Ryan, 1985, 2000) faydalanarak iş-aile çatışmasının temelinde yatan güdüsel süreçleri anlamak; ikincisi ise, hem iş ve aileye yönelik motivasyonların öncüllerini (iş özellikleri, iş desteği, eş desteği, ve evde algılanan control) hem de iş-aile çatışmasının temel sonuçlarını (iş doyumu, iş kaynaklı duygusal tükenmişlik, aile doyunumu, aile kaynaklı duygusal tükenmişlik, ve hayat doyumu) içeren bütünleştirici bir model sunmaktır. Ayrıca, iş ve aile rol özdeşimlerin iş-aile çatışması boyutları (İAÇ ve AİÇ) ile doyumusal sonuçlar arasındaki ilişkiler üzerindeki düzenleyici rolünü incelemek de çalışmanın diğer bir amacıdır. Bu amaçları gerçekleştirmek üzere çalışma iki aşamada gerçekleştirilmiştir. İlk olarak çalışmada kullanılan ölçüm araçlarının faktör yapılarını ve iç tutarlılıklarını değerlendirmek için 407 evli, çift kazançlı ve 18 yaşından küçük en az bir çocuğu olan bireyler üzerinde bir ön çalışma gerçekleştirilmiştir. Ölçeklerin yeterli psikometrik özelliklere sahip olduğu desteklendikten sonra önerilen ilişkileri ve modeli test etmek için bir ana çalışma yapılmıştır. Dört yüz beş evli, çift kazançlı ve 18 yaşından küçük en az bir çocuğu olan bireyler üzerinde yapılan analizler genel olarak öngörülen ilişkileri

desteklemiştir. Beklendiđi biçimde, işe yönelik özerk motivasyon İAÇ'yı, aileye yönelik özerk motivasyon ise AİÇ'yı negative bir biçimde yordamıştır. Ancak, beklenenin aksine işe yönelik ve aileye yönelik motivasyonun iş-aile çatışması boyutları üzerinde etkileşimli etkisi bulunamamıştır. İş-aile çatışması boyutları ve doyumsal değişkenler arasındaki ilişkiler de anlamlı çıkmamıştır. Bulgular tartışılmış, çalışmanın katkıları ve uygulamaya yönelik çıkarımları sunulmuştur.

Anahtar Kelimeler: iş-aile çatışması, özbelirleme, motivasyon, doyum, tükenmişlik





To my precious family

ACKNOWLEDGMENTS

First of all, I would like to express my deepest gratitude to my thesis advisor Prof. Dr. Reyhan Bilgiç for her support, guidance and patience. Not only during my thesis study, but also throughout my education in psychology program, she was always by my side whenever I needed, she always expressed her confidence in my abilities, she supported and encouraged me when I felt down and helpless, and gave valuable advices in my hardest times. She has always inspired me with her wisdom, knowledge and productivity. Dear Prof. Dr. Reyhan Bilgiç, I am very glad to know you and become your student.

I would also like to thank my thesis supervising committee members, Assoc. Prof. Dr. Türker Özkan and Assoc. Prof. Dr. Pınar Acar, for sparing time for my study despite their busy schedule and the contributions they made during my dissertation process. I also want to thank my other examining committee members, Asst. Prof. Dr. A. Başak Ok and Asst. Prof. Dr. Ayça Özen Çıplak for not turning my request and accepting to be jury members. I am indebted to them for their constructive feedback and goodwill.

This thesis process was not only a journey toward academic advancement but also was a journey toward my inner self. Throughout this process, I have come to know my strengths as well as my weaknesses and my limits, and what happens if I try to exceed these limits. Therefore, I thank so much to Dr. Şaziye Kazezoğlu Çevik and Clinical Psychologist Biseng Özdiñç for assisting me in this journey. Without their care and support it would be impossible for me to complete this thesis.

My family is the best and the most precious thing in my life. My mother Hamiyet Yalçın, my father Dursun Yalçın and my sister Ezgi Yalçın, I love you! I thank you for being in my life, for your love and support.

I am also thankful to the members of Çankaya University Psychology Department members, Prof. Dr. Ali Dönmez, Assoc. Dr. Aslı Göncü Köse, Asst. Prof. Hande Kaynak, Asst. Prof. Dr. Erol Özçelik, Asst. Prof. Dr. Merve Topcu, my former colleague Dr. Tuğba Yılmaz, our research assistant Merve Denizci Nazlıgöl, and Pınar Aşur for showing the importance of work support, for their consideration and bearing with my complaints and for calming me down during my anxiety crises.

I would like to thank to Assoc. Prof. Dr. Ahmet Uysal and Zeynep Gaye Çenesiz for helping me in development of SDT items, İlker Dalgıç for helping me in statistical analyses, my dear friends Öykü –İbrahim Çalışır, Gülçim Bilim, Tuba Yumuşak, Burçin-Muhammed Sarıca, Birce Ergör, Burcu Mamak, Aslı Taşcı, Nagehan Yıldırım, Nil Avcı, Yeşim Üzümcüoğlu, and Pınar Bıçaksız for simply putting up with me and always being by my side.

I also appreciate the contributions of my student assistants, Bige Hazal Özgürdal, Bengisu Gül, and Merve Marval, and I really thank to them for helping me in duplication and preparation of questionnaire packages, delivery of surveys and data entry. Girls, I owe much to you! I am also grateful to all of my other psychology students who voluntarily participated in data collection and data entry process.

Lastly, I would like to thank to TUBITAK-BİDEB National Scholarship Programme for the financial support it provided me throughout my graduate education, without it I would be unable to pursue a Ph.D. degree .

TABLE OF CONTENTS

PLAGIARISM	iii
ABSTRACT	iv
ÖZ.....	vi
DEDICATION	viii
ACKNOWLEDGMENTS	ix
TABLE OF CONTENTS	xi
LIST OF TABLES	xviii
LIST OF FIGURES	xix
LIST OF ABBREVIATIONS	xx
CHAPTER	
1. INTRODUCTION	1
1.1. Overview of the Literature	1
1.1.1. Work-Family Conflict	5
1.1.2. The Self-Determination Theory.....	8
1.1.2.1. Self-Determined Motivation and Work-Family Conflict	13
1.1.3. Work Context and Self-Determined Motivation	16
1.1.3.1. Job Characteristics Model	16
1.1.3.2. Job Characteristics and Self-Determined Motivation	19
1.1.3.3. Work Support and Self-Determined Motivation.....	21
1.1.4. Family Context and Self-Determined Motivation	24
1.1.4.1. Spousal Support and Self-Determined Motivation	24
1.1.4.2. Perceived Control at Home and Self-Determined Motivation	27
1.1.5. Outcomes of Work-Family Conflict.....	30
1.1.5.1. Relationships Between Work-Family Conflict, and Job and Family Satisfaction	30
1.1.5.2. Relationships Between Work-Family Conflict, and Emotional Exhaustion	31

1.1.5.3. Relationships Among WFC Dimensions, Emotional Exhaustion, Job and Family Satisfaction	32
1.1.5.4. Life Satisfaction	36
1.1.6. Direct Relationships Between Antecedents of Self-Determined Motivation and WFC Outcomes.....	36
1.1.7. Identity Theory	41
1.1.7.1. Moderating Effects of Identification with Work (Family) Role in the Relationships between WFC Dimensions, and Job and Family Satisfaction	42
1.2. The Proposed Model of Work-Family Conflict.....	45
2. PILOT STUDY.....	49
2.1. Method	49
2.1.1. Sample	49
2.1.2. Procedure.....	50
2.1.3. Measures.....	50
2.1.3.1. Work-Family Conflict.....	50
2.1.3.2. Motivation Toward Work	51
2.1.3.3. Job Characteristics	52
2.1.3.4. Work Support.....	52
2.1.3.5. Emotional Exhaustion at Work.....	53
2.1.3.6. Job Satisfaction	53
2.1.3.7. Spousal Support	53
2.1.3.8. Perceived Control at Home	54
2.1.3.9. Motivation Toward Family	54
2.1.3.10. Family Satisfaction	55
2.1.3.11. Emotional Exhaustion at Home	56
2.1.3.12. Life Satisfaction	56
2.1.3.13. Demographics and Control Variables	56
2.2. Results.....	57
2.2.1. Work-Family Conflict	57

2.2.2. Motivation Toward Work.....	57
2.2.3. Job Characteristics.....	58
2.2.4. Work Support.....	59
2.2.5. Emotional Exhaustion at Work.....	59
2.2.6. Job Satisfaction.....	59
2.2.7. Spousal Support.....	60
2.2.8. Perceived Control at Home.....	60
2.2.9. Motivation Toward Family.....	60
2.2.10. Emotional Exhaustion at Home.....	61
2.2.11. Family Satisfaction.....	62
2.2.12. Life Satisfaction.....	62
2.3. Discussion Concerning the Factor Analyses and Simplex Patterns of WEIMS and Motivation Toward Family Scale.....	63
3. MAIN STUDY- METHOD.....	65
3.1. Method.....	65
3.1.1. Sample.....	65
3.1.2. Procedure.....	66
3.1.3. Measures.....	66
3.1.3.1. Identification with Work Role.....	67
3.1.3.2. Identification with Family Role.....	67
3.1.3.3. Motivation Toward Work.....	68
3.1.3.4. Motivation Toward Family.....	68
4. MAIN STUDY- RESULTS.....	69
4.1. Descriptive Statistics and Bivariate Correlations.....	69
4.1.1. Bivariate Correlations Among the Variables.....	69
4.2. Hypotheses Testing.....	70
4.2.1. Testing of the Proposed Model via Path Analysis.....	70
4.2.2. Testing of the Combined Effects of Motivation on WFC Dimensions.....	83

4.2.3. Moderating Influences of Work/Family Role Identification on the Cross-domain Effects of Work-Family Conflict.....	85
5. DISCUSSION.....	90
5.1. Discussion of the Study Findings	91
5.1.1. Hypotheses Testing and Main Findings	91
5.1.2. Mediations and Indirect Effects	102
5.1.3. Correlations of the Study Variables	105
5.2. Strengths and Contrubitions of the Study	107
5.3. Practical Implications.....	110
5.4. Limitations and Suggestions for Future Research	114
REFERENCES	118
APPENDICES	
A1. PARTICIPANT INFORMED CONSENT	150
A2. PARTICIPANT DEBRIEFING FORM.....	151
B1. WORK-FAMILY CONFLICT & FAMILY-WORK CONFLICT SCALE.....	152
B2. WORK EXTRINSIC AND INTRINSIC MOTIVATION SCALE (WEIMS)	153
B3. JOB DIAGNOSTIC SURVEY.....	155
B4. WORK SUPPORT SCALE.....	158
B5. EMOTIONAL EXHAUSTION AT WORK SCALE.....	159
B6. JOB SATISFACTION SCALE	160
B7. SPOUSAL SUPPORT SCALE	161
B8. PERCIEVED CONTROL AT HOME SCALE.....	162
B9. MOTIVATION TOWARD FAMILY SCALE	163
B10. FAMILY SATISFACTION SCALE.....	167
B11. EMOTIONAL EXHAUSTION AT HOME SCALE	168
B12. LIFE SATISFACTION SCALE.....	169
B13. ITEMS FOR DEMOGRAPHICS AND CONTROL VARIABLES	170

B14. IDENTIFICATION WITH WORK ROLE	
SCALE - MAIN STUDY	171
B15. IDENTIFICATION WITH FAMILY ROLE	
SCALE – MAIN STUDY.....	172
C1. EXPLANATORY FACTOR ANALYSIS RESULTS	
FOR WORK-FAMILY CONFLICT SCALE	173
C2. EXPLANATORY FACTOR ANALYSIS RESULTS	
FOR WEIMS SCALE AND EXCLUDED ITEMS	174
C3. EXPLANATORY FACTOR ANALYSIS RESULTS	
FOR JOB DIAGNOSTIC SURVEY	175
C4. EXPLANATORY FACTOR ANALYSIS RESULTS	
FOR WORK SUPPORT SCALE	177
C5. EXPLANATORY FACTOR ANALYSIS RESULTS	
FOR EMOTIONAL EXHAUSTION AT WORK SCALE.....	178
C6. EXPLANATORY FACTOR ANALYSIS RESULTS	
FOR JOB SATISFACTION SCALE	179
C7. EXPLANATORY FACTOR ANALYSIS RESULTS	
FOR SPOUSAL SUPPORT SCALE	180
C8. EXPLANATORY FACTOR ANALYSIS RESULTS	
FOR PERCEIVED CONTROL AT HOME SCALE.....	181
C9. EXPLANATORY FACTOR ANALYSIS RESULTS	
FOR MOTIVATION TOWARD FAMILY SCALE AND	
EXCLUDED ITEMS	182
C10. EXPLANATORY FACTOR ANALYSIS RESULTS FOR	
EMOTIONAL EXHAUSTION AT HOME SCALE.....	184
C11. EXPLANATORY FACTOR ANALYSIS RESULTS	
FOR FAMILY SATISFACTION SCALE	185
C12. EXPLANATORY FACTOR ANALYSIS RESULTS	
FOR LIFE SATISFACTION SCALE.....	186

D1. CONFIRMATORY FACTOR ANALYSIS RESULTS FOR WORK-FAMILY CONFLICT SCALE	187
D2. CONFIRMATORY FACTOR ANALYSIS RESULTS FOR WEIMS SCALE AND EXCLUDED ITEMS	188
D3. CONFIRMATORY FACTOR ANALYSIS RESULTS FOR JOB DIAGNOSTIC SURVEY AND EXCLUDED ITEMS	189
D4. CONFIRMATORY FACTOR ANALYSIS RESULTS FOR WORK SUPPORT SCALE	190
D5. CONFIRMATORY FACTOR ANALYSIS RESULTS FOR EMOTIONAL EXHAUSTION AT WORK SCALE	191
D6. CONFIRMATORY FACTOR ANALYSIS RESULTS FOR JOB SATISFACTION SCALE	192
D7. CONFIRMATORY FACTOR ANALYSIS RESULTS FOR IDENTIFICATION WITH WORK ROLE SCALE AND THE EXCLUDED ITEM	193
D8. CONFIRMATORY FACTOR ANALYSIS RESULTS FOR SPOUSAL SUPPORT SCALE	194
D9. CONFIRMATORY FACTOR ANALYSIS RESULTS FOR PERCEIVED CONTROL AT HOME SCALE.....	195
D10. CONFIRMATORY FACTOR ANALYSIS RESULTS FOR MOTIVATION TOWARD FAMILY SCALE AND EXCLUDED ITEMS	196
D11. CONFIRMATORY FACTOR ANALYSIS RESULTS FOR EMOTIONAL EXHAUSTION AT HOME SCALE.....	197
D12. CONFIRMATORY FACTOR ANALYSIS RESULTS FOR FAMILY SATISFACTION SCALE.....	198
D13. CONFIRMATORY FACTOR ANALYSIS RESULTS FOR IDENTIFICATION WITH FAMILY ROLE SCALE AND THE EXCLUDED ITEM	199

D14. CONFIRMATORY FACTOR ANALYSIS RESULTS FOR LIFE SATISFACTION SCALE.....	200
E. CURRICULUM VITAE	201
F. TURKISH SUMMARY/ TÜRKÇE ÖZET	203
G. TEZ FOTOKOPİSİ İZİN FORMU	232



LIST OF TABLES

TABLES

Table 1 Number of Scale Items, Internal Consistency Reliabilities, Bivariate Correlations, Means and Standard Deviations of the Study Variables	71
Table 2 Summary of Proposed Hypotheses, Results and Findings from the Literature	88



LIST OF FIGURES

FIGURES

Figure 1 Self – Determination Continuum.....	11
Figure 2a The Proposed Model of Work-Family Conflict.....	47
Figure 2b The Proposed Model of Work-Family Conflict	48
Figure 3 The Modified Model of Work-Family Conflict	74
Figure 4 Path Analysis Results of the Modified Model for the Work Domain	81
Figure 5 Path Analysis Results of the Modified Model for the Family Domain	82
Figure 6 Interaction of Family-to-Work Conflict and Family Role Identification on Job Satisfaction.....	87

LIST OF ABBREVIATIONS

AMO	Amotivation
EXT	Extrinsic Motivation
F-SDI	Family Self-Determination Index
F-to-WC	Family-to-Work Conflict
IDENT	Identified Motivation
IM	Intrinsic Motivation
INTEG	Integrated Motivation
INTRO	Introjected Motivation
MPS	Job's Motivating Potential Score
WFC	Work-to- Family Conflict
W-SDI	Work Self-Determination Index
W-to-FC	Work-to-Family Conflict

CHAPTER 1

INTRODUCTION

1.1. Overview of the Literature

With enhanced participation of women in the work force and increased competitiveness in business world that require employees to work long hours, researchers have devoted considerable effort to examine the dynamics of family and work life. Eventually, the concept of Work-Family Conflict (WFC), which is defined as a role conflict resulting from incompatible work and family demands (Greenhaus & Beutell, 1985), emerged. The introduction of the concept of WFC has sparked enormous interest among industrial and organizational psychologists. Ever year, dozens of studies examining the relationships between WFC and various constructs have been published. Yet, despite numerous calls from scholars (La Guardia & Patrick, 2008; Poelmans, 2001; Senecal, Vallerand, & Guay, 2001; Warner & Hausdorf, 2009) the motivational aspects of it remained unstudied. However, examination of the motivational basis of work-family interplay is important and may help us understand why people experience work-family conflict in the first place. Hence, the overarching aim of the present study is to explore the motivational underpinnings of WFC. While doing so, this study mainly relies on Self-Determination Theory (SDT; Deci & Ryan, 1985, 2000), one of the most influential motivational theories of human behavior, and argues that the experience of work-family conflict primarily results from one's motivational orientation toward his/her family and toward his/her work. To the knowledge of the researcher, there is only one empirical study (Senecal, Vallerand, & Guay, 2001) which has applied Self-Determination Theory to the WFC research. Although Senecal et al. (2001) found that family-related and work-related motivation predicted work-family conflict through their effects on family alienation; one major shortcoming of their work was its conceptualization of WFC as a unidimensional construct. However, several researchers (e.g., Frone, Yardley, & Markel, 1997; Gutek, Searle, & Klepa, 1991;

Mesmer-Magnus & Viswesvaran, 2005) have established that WFC, indeed, involves two dimensions; one representing the intrusion of work into the family domain (work to family conflict; W-to-FC) and the other representing the intrusion of family to the work domain (family to work conflict; F-to-WC). Since it has been showed that each facet has its unique antecedents and consequences (e.g., Frone et al., 1997; Frone, Russel, & Cooper, 1992), recognition of the bi-dimensional nature of WFC is critical. Thus, in the present study the effects of motivational orientations will be examined separately for the dimensions of W-to-FC and F-to-WC.

The current study not only aims to examine the relationship between motivation and WFC, but also intends to identify the factors that affect motivation in both work and family contexts. According to Job Characteristics Model (Hackman & Olham, 1976, 1980), job characteristics may have a profound impact on employee motivation. Therefore, the design of the job is considered to be one of the important determinants of work motivation. Along with job characteristics, support from the work place is also utilized as a predictor of work-related motivation. With respect to family domain, social support from the spouse (or partner) and perceptions of control regarding family-related issues are thought to be basic predictors of family-related motivation. Although there have been studies that has examined the effects of these constructs on motivation within different life contexts (Amoura, Berjot, Gillet, & Altıntaş, 2014; d'Ailly, 2003; Hadden, Rodriguez, Knee, & Porter, 2015; Ratelle, Simard, & Guay, 2012), no research up to date, has simultaneously investigated their impacts in one single study. In this respect, the present study is expected to contribute to the existent literature.

As far as the outcomes of WFC are concerned, two competing hypotheses dominate the relevant literature. While *matching hypothesis* (Cohen & Wills, 1985) states that conflict originating from one domain (e.g., work) should have more detrimental effects on the outcomes in the same domain (e.g. work), *cross-domain hypothesis* (Frone et al., 1992) maintains that conflict arising from one domain should have more detrimental effects on the outcomes in the other domain (e.g. family). To date, research has provided support for both hypotheses revealing

contradictory results. For instance, while some researchers found that W-to-FC was the main antecedent of family related outcomes like family/marital satisfaction (Aycañ & Eskin, , 2005; Carlson & Kacmar,2000; Mihelic & Tekavcic, 2014) whereas F-to-WC was the main determinant of work related outcomes like job/career satisfaction and job distress (Frone et al., 1997; Mesmer-Magnus & Viswesvaran, 2005; Mihelic & Tekavcic, 2014), other researchers showed that W-to-FC was more strongly associated with job satisfaction (Amstad, Meier, Fasel, Elfering , & Semmer, 2010; Beutell, 2010; Shockley & Singla, 2011) whereas F-to-WC was more strongly associated with family/marital satisfaction (Amstad et al., 2010; Beutell, 2010; Lapierre et al., 2008; Minnotte, Minnotte, & Bonstrom; 2015; Shockley & Singla, 2011). Indeed, there were still others which could not obtain significant relationships between WFC dimensions and satisfaction outcomes (Aryee, Luk, Leung, & Lo, 1999; O'Driscoll, Ilgen, & Hildreth, 1992). Therefore, in the present study both hypotheses will be tested to clarify the effects of W-to-FC and F-to-WC on work related outcomes of job satisfaction, emotional exhaustion at work, and family related outcomes of family satisfaction and emotional exhaustion at home.

According to Frone et al. (1992), an integrative, comprehensive model of WFC should include not only domain specific satisfaction outcomes but also involve general indices of well-being. Therefore, life satisfaction is utilized as the ultimate outcome in the present study. More specifically, it is predicted that WFC will exert its effects on life satisfaction via job and family satisfaction.

Another limitation of the WFC research concerns the underexamination of the effects of individuals' role priorities (Zedeck & Mosier, 1990). Although many researchers (Carlson & Kacmar, 2000; Eby, Casper, Lockwood, Bordeaux, & Brinley, 2005) argued that the impact of WFC might change depending on the value (or meaning) an individual attaches to his/her work and family roles, few studies have investigated the moderating effects of role-identification on the relationship between WFC and its potential consequences. Moreover, most of these studies revealed incompatible findings. To illustrate, Bagger, Li and Gutek (2008) reported a

negative relationship between F-to-WC and job satisfaction only at low levels of family role identification whereas Carr, Boyar and Gregory (2008) indicated that the effects of W-to-FC on job satisfaction were more detrimental at high levels of family role identification. On the other hand, on a sample of employed women, Noor (2004) obtained non-significant results for the moderating effect of family role identification on the relationship between W-to-FC and job satisfaction. However, the researcher found a positive relationship between W-to-FC and job distress at high levels of work identification. Keeping these contradictory findings in mind and in an attempt to disentangle the effects of role identification, the current study mainly benefits from the assumptions of the Identity Theory (Stryker, 1980, 1987), and explores the moderating roles of work/family identification in the relationships between WFC dimensions and domain specific satisfaction outcomes.

In addition to the limitations mentioned above, it seems that the research on WFC also suffers from certain methodological problems. According to Kossek and Ozeki (1998), the unstable relationships concerning WFC and its outcomes likely to result from the use of homogenous samples which limit the scope of studies to certain professions. In the present study, this issue will be addressed by utilizing a heterogeneous sample of individuals working in different types of jobs.

To overcome these limitations and expand the literature, the current study is designed to examine the concept of WFC from the Self-Determination Theory perspective and introduce an integrative model that not only involves the proximal consequences (e.g., job satisfaction, family satisfaction, emotional exhaustion both at work and at home) but also distal outcomes (e.g., life satisfaction) of WFC, as well as its possible proximal (e.g., motivation toward work and motivation toward family) and distal antecedents (e.g., job characteristics, work support, perceived control at home, spousal support). Moreover, since previous research (e.g., Bagger et al., 2008; Carr et al., 2008; Noor, 2004) obtained inconsistent findings regarding the moderating effects of work/family identification, the moderating roles of these variables in the relationship between WFC and satisfaction outcomes will also be explored.

In the subsequent sections, first, the literature concerning work-family conflict and Self-Determination Theory will be reviewed. Then, the relevant research on the constructs utilized in the current study (job characteristics, work support, spousal support, perceived control at home, job satisfaction, family satisfaction, emotional exhaustion, life satisfaction, work/family role identification) will be summarized and the hypotheses concerning the relationships among these constructs will be introduced. Eventually, a comprehensive model of WFC, which involves and integrates the proposed hypotheses, will be presented.

1.1.1. Work-Family Conflict

Work-family conflict (WFC) is a type of inter-role conflict, which occurs when the demands of work and the family become incompatible with each other (Greenhaus & Beutell, 1985). That is, meeting the responsibilities of one domain (e.g. work) interferes with performance of the responsibilities of the other domain (e.g. family) and makes it difficult for individuals to participate in two roles (work and family roles) simultaneously. The notion of WFC draws from the *scarcity hypothesis* which argues that obligations and pressures associated with one role leads to negative reactions such as strain, negative affect or depression and, by consuming the limited resources (e.g., time, energy) of the individual, reduces his/her engagement in another role (Rothbard, 2001).

According to Greenhaus and Beutell (1985), WFC is a multi-dimensional construct that involves *time-based*, *strain-based* and *behavior-based* conflict. Time-based conflict takes place when preoccupation with one role (e.g. family) limits the time devoted to activities demanded by the other (e.g. work). Inflexible work schedules, frequency of overtime, extensive travelling and irregular shift works are the main job-related sources of time-based WFC (Allen et al., 2012; Burke, Weir, & DuWors, 1980; Greenhaus & Beutell, 1985; Pleck, Staines, & Lang, 1980). Family characteristics such as presence of young children, partner's employment status, elderly caregiving and having a small vs. large family also contribute to the experiences of time-related WFC (Barrah, Shultz, Baltes, & Stolz, 2004; Greenhaus

& Beutell, 1985; Greenhaus & Kopelman, 1981; Hall & Gordon, 1973). Strain-based conflict occurs when stressors within one domain create feelings of strain, fatigue or irritability, affecting the individual's performance in the other domain and making it difficult for him/her to comply with the demands of the both roles. Related literature suggests that work-related variables of work-role conflict, work-role ambiguity, changes in work environment, low levels of leader support and task-autonomy (Frone et al., 1997; Greenhaus & Beutell, 1985; Jones & Butler, 1980; Parasuraman, Greenhaus, & Granrose, 1992; Voydanoff, 2004a) and family related variables of disagreement between partners, distress experienced in family environment, dissimilarity of attitudes, low levels of spousal support (Frone et al., 1997; Greenhaus & Beutell, 1985; Rosenbaum & Cohen, 1999; Voydanoff, 2004b) may be positively related to strain-based WFC. Lastly, behavior-based conflict represents the situation that the behavioral patterns displayed in one role are incompatible with the behavioral expectations regarding other role. To illustrate, managers who are expected to be authoritative, impersonal and emotionless may be unable to adjust their behaviors to meet family's expectations of being emotional, caring, sensitive, and open (Greenhaus & Beutell, 1985; Greiff & Munter; 1980). Thus, work role related behavioral expectations for secretiveness, self-reliance, objectivity and family role related behavioral expectations for warmth, vulnerability and openness are considered to be major sources of behavioral based WFC.

Although initial studies utilized WFC as a unidimensional construct, later research (e.g., Gutek et al., 1991) showed that WFC consists of two related but separate dimensions: namely, work to family conflict (W-to-FC) and family to work conflict (F-to-WC). While W-to-FC represents the situations in which work requirements interfere with family requirements, reducing individuals' performance in the family domain, F-to-WC occurs when family requirements interfere with work requirements, reducing individuals' performance in the work domain. Studies have also shown that the work and family boundaries are *asymmetrically permeable*, signifying the prevalence of work demands interfering with the family demands

(Pleck et al., 1980). That is, individuals are more likely to report W-to-FC than F-to-WC (Frone et al., 1992; Greenhaus & Beutell, 1985; Gutek et al., 1991).

Extant literature points out that W-to-FC and F-to-WC have unique antecedents and outcomes specific to each domain (Byron, 2005; Frone, et al., 1992; Kelloway, Gottlieb, & Barham, 1999; Kossek & Ozeki, 1998; Michel, Kotrba, Mitchelson, Clark, & Baltes, 2011). For example, studies have found that while work-related stress, work overload, inflexible work hours, work commitment, work support were found to be proximal antecedents of W-to-FC, family-related stress, parental overload, family involvement, spousal support were found to be basic predictors of F-to-WC (Byron, 2005; Carlson, Kacmar, & Williams, 2000; Ford, Heinen, & Langkamer, 2007; Frone et al., 1992; Frone et al., 1997).

With respect to outcomes, W-to-FC was found to be negatively related to job satisfaction (Bruck, Allen, & Spector, 2002; Burke, 1988; Kossek & Ozeki, 1998; Thomas & Ganster, 1995), career satisfaction (Martins, Eddleston, & Veiga, 2002), and positively related to turnover intentions (Boyar, Carson, Mosley, Maertz, & Pearson, 2006), job stress (Grandey & Cropanzano, 1999), and job burnout (Blanch & Aluja, 2012; Haines, Harvey, Durand, & Marchand, 2013) whereas F-to-WC was found to be positively associated with family distress (Grandey & Cropanzano, 1999), and negatively associated with family satisfaction (Turliuc & Buliga, 2014; Judge, Illies, & Scott, 2006), family performance (Frone et al., 1997), quality of parent-child relationship (Cinamon, Weisel & Tzuk, 2007) and family well-being (Kinnunen & Mauno, 1998).

Additionally, overall WFC was shown to be negatively correlated with life satisfaction (Carlson & Kacmar, 2000; Carlson et al., 2000; Kossek & Ozeki, 1998) and positively correlated with life stress (Parasuraman & Simmers, 2001; Parasuraman et al., 1992), psychological distress (O'Driscoll et al., 1992), depression (Frone, Russell, & Barnes, 1996) and substance use (Frone, 2000).

Apart from domain-specific effects, several researchers (Carlson & Kacmar, 2000; Frone et al., 1997; Judge et al., 2006) argued that the impacts of the conflict experienced in one domain (e.g., work) may be carried over into the other domain

(e.g. family) leading to detrimental outcomes in that domain. These arguments were confirmed by several studies that found differential cross-domain effects of conflict dimensions on both work and family related outcomes. Specifically, several studies documented that W-to FC was negatively associated with family/marital satisfaction, (e.g., Carlson et al., 2000; Judge et al., 2006), family involvement (Parasuraman, Purohit, Godshalk, & Beutell, 1996), and family performance (Carlson, Grzywacz, & Kacmar, 2010) whereas F-to-WC was negatively associated with job satisfaction (Carlson et al., 2000), job performance (Dugan, Matthews, & Barnes-Farrell, 2012) and organizational commitment (Carlson et al., 2000).

Despite this extensive research, one obvious limitation of the relevant literature is the underexamination of motivational aspects of WFC. Yet, motivational processes may determine the type and the degree of the conflict experienced by individuals. Indeed, as being one of the most prominent theories of motivation, Self-Determination Theory (SDT; Deci & Ryan, 1985; Ryan & Deci, 2000) may explain why and how some individuals are more likely to experience W-to-FC/ F-to-WC, or both. Therefore, in the following sections, first, the basic assumptions of SDT will be introduced, and then its links to WFC will be established.

1.1.2. The Self-Determination Theory

Self-Determination Theory (SDT; Deci & Ryan, 1985; Ryan & Deci, 2000) maintains that human beings have an innate tendency toward self-actualization, self-integration and personal growth. However, according to SDT, although this integrative, growth-promoting tendency is a fundamental process guiding human behavior, there are certain social-environmental features that either thwart or facilitate this process. That is, people's ultimate goal to achieve a unified, coherent and elaborated sense of self depends on specific contextual factors. These contextual factors create an environment, which either support or undermine development of a healthy self-concept and effective human functioning by satisfying or hampering *basic psychological needs* (Deci & Ryan, 1985, 2000, 2008; Ryan, 1995; Ryan & Deci, 2000).

According to the theory, there are *three* basic needs to be satisfied for maintaining and enhancing psychological growth and personal well-being. They are referred as the needs for *competence*, *autonomy* and *relatedness* (Deci & Ryan, 1985, 2000; Ryan, 1995; Ryan & Deci, 2000). Since competence is a perceived sense of confidence, which signifies the fact that one is effectively dealing with his/her social environment and exercising his/her skills (capacities) within this environment (Harter, 1983), satisfaction of the need for competence allows human beings to experience feelings of competency and power to succeed at challenges, helping them attain (or maintain) skills, knowledge and other desired outcomes. Relatedness, on the other hand, refers to the perception that one is related to other people and his/her community (Baumeister & Leary, 1995). Therefore, satisfaction of the need for relatedness gives individuals a sense of integrity with others and feelings of security, acceptance, respect and consideration. Lastly, autonomy refers to the perception that one is the causal agent of his/her own actions (deCharms, 1968; Deci & Ryan, 1985). Hence, fulfillment of the autonomy need allows people to express their true selves through their actions, to behave in concordance with their interests and leads to feelings of volition and determination. SDT posits that these three basic needs are universal in the sense that they are not culture or time-bounded. Across various developmental periods, cultures, and settings satisfaction of all of these needs is required for optimal functioning and psychological well-being.

An important point made by SDT concerns the categorization of motivation that guides human behavior. According to SDT, there are three fundamental kinds of motivation; namely, *amotivation*, *extrinsic motivation* and *intrinsic motivation* (Deci & Ryan, 1985, 2000). Amotivation is defined as the absence of intention and interest to behave (Bandura, 1986). Amotivation may be a result of either perceived incompetence, lack of autonomy or devaluation of the activity in question (Deci & Ryan, 2002). On the other hand, extrinsic motivation refers to performing a behavior for a separate outcome, other than the enjoyment of the activity itself whereas intrinsic motivation reflects engaging in a behavior for the satisfaction derived from it (Deci & Ryan, 1985; Vallerand, 1997).

SDT maintains that these three types of motivation can be lined up along a continuum depending on the degree of autonomy inherent in them. At the very low end of this continuum, amotivation is placed. Since amotivation represents a complete lack of intention to behave in a particular way, it results in non-regulation of behavior. The next type of motivation lying along the continuum is external motivation which represents the least autonomous form of extrinsic motivation and involves the lowest degree of self-determination. When externally motivated, individuals perform or avoid an activity only because of anticipated rewards and punishments. According to Ryan and Deci (2000), external motivation can be a cause of alienation and passive compliance. In fact, this type of motivation (or regulation) lies at the very heart of early behaviorist approach and is generally contrasted with intrinsic motivation (see deCharms, 1968; Skinner, 1953 for example). The other type of behavioral regulation is introjected regulation. Although introjected regulation is a relatively more autonomous form of extrinsic motivation, it is internalized only to some degree and therefore, still considered to be externally driven. In the case of introjected regulation, the behavior is accomplished in order to refrain from feelings of fear, guilt or shame or to maintain the feelings of self-worth and pride. The third type of extrinsic motivation refers to identified regulation, which involves identification with the behavior itself and attaching a personal value to it.

Although identification entails a high level of autonomy and self-determination, it is subsumed under the category of extrinsic motivation because identification does not necessarily entail the integration of the behavior with one's personal value system. Integrated regulation represents the last and the most autonomous form of extrinsic motivation. Here, the behavior is eventually integrated with the other aspects of the self and perceived as congruent to one's identity. While integrated regulation is akin to intrinsic motivation, it is distinguished from the intrinsic motivation in that the behavior is still performed for instrumental purposes other than the enjoyment of the activity itself. On the other hand, intrinsic motivation is characterized by the feelings of volition, interest and satisfaction accompanied by

the engagement in the activity (Deci & Ryan, 1985, 2000). In contrast to extrinsic forms of regulation where the perceived locus of control is external, intrinsic motivation involves an internal locus of causality in the sense that when intrinsically motivated, people perceive themselves to be the only source or the initiator of their actions. Intrinsic motivation, as being the most self-determined way of action, is placed at the highest end of the continuum.

Deci and Ryan (1985, 2000) suggest that it is possible to make a broader categorization across self-determination continuum. More specifically, according to authors, two forms of extrinsic motivation, namely, external and introjected motivation can also be referred as *controlled motivation* whereas the other two remaining forms of extrinsic motivation (identified and integrated motivation) can be referred as *autonomous (or self-determined)* motivation. In contrast to these two types of motivation that require an intention to act, amotivation, however, lacks intentionality and therefore represents the third type of regulation. This self-determination (or relative autonomy) continuum proposed by Deci and Ryan (1985, 2000, 2008) is presented below, in *Figure 1*.

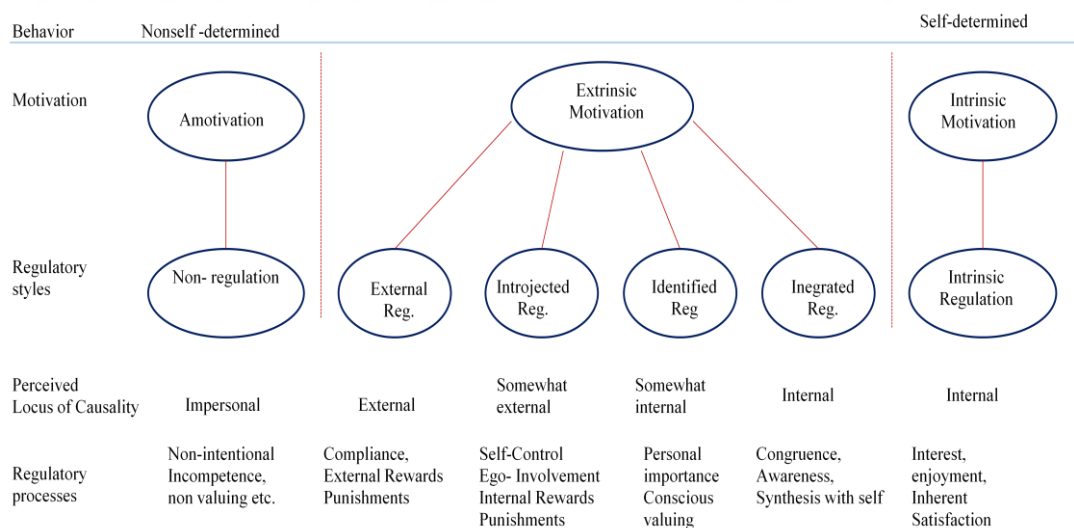

Figure 1 Self – Determination Continuum (Deci & Ryan, 1985, 2000, 2008)

A central tenet of SDT is that significant relationships exist between need satisfaction and motivation (Deci & Ryan, 1985, 2000, 2008). The basic needs for autonomy, competence and relatedness are required to be satisfied for enhancement of personal well-being and facilitation of optimal functioning. Therefore, any social context that satisfies these needs also promotes intrinsic (or autonomous) motivation and, in turn, leads to personal growth, self-actualization and effective performance. Conversely, environments that thwart these needs undermine intrinsic (or autonomous) motivation, lead to more controlled and extrinsic forms of regulation, and therefore result in decreased levels of psychological well-being and poor functioning.

These basic arguments and hypotheses of SDT have been tested and confirmed by a large number of studies across several domains. The taxonomy of kinds of motivation and the proposed factor structure of motivations have been supported with results showing that different types of regulatory styles revealed a quasi-simplex pattern; that is, motivation types located more closely on the self-determination continuum (e.g., integrated motivation and identified motivation) displayed stronger positive correlations than those motivation types located farther away (e.g., integrated motivation and external motivation) along the self-determination continuum (Chirkov, Ryan & Willness, 2005; Hayamizu, 1997; Ryan & Cornell, 1989). Moreover, several studies revealed that these different forms of motivations were differentially associated with a wide range of outcomes; suggesting that more autonomous forms of motivation were related to higher levels of psychological well-being (e.g., Milyavskaya & Koestner, 2011; Ryan & Deci, 2001), increased performance at school (e.g., Black & Deci, 2000; Guay, Ratelle, Roy, & Litalien, 2010), higher levels of commitment and adherence to physical exercise or sports (Vansteenkiste & Deci, 2003), creativity (Grant & Berry, 2011; Liu et al., 2013) healthier behaviors (e.g., Hartmann, Dohle, & Siegrist, 2015; Niemiec, Ryan, Deci, & Williams, 2009), enhanced family/close relationships (Hadden et al., 2015; Uysal, Lin, & Knee, 2010), increased job satisfaction (Güntert,

2015; Millette & Gagne, 2008) and reduced levels of job-burnout (Fernet, Austin, Trépanier, & Dussault, 2013; Van den Broeck, Vansteenkiste, De Witte, & Lens, 2008).

The links between need satisfaction and motivation were also established by numerous studies. Findings showed that whereas autonomy support was positively related to intrinsic motivation (Ryan & Grolnick, 1986), threats (Deci & Cascio, 1972 as cited in Deci & Ryan, 2000), tangible rewards (Deci, 1971), and lack of choice (Zuckerman, Larrance, Porac, & Blanck, 1980) undermined intrinsic motivation. Similarly, thwarting the needs for competence (such as providing negative feedback) and relatedness (such as avoiding interaction) was found to be negatively associated with intrinsic motivation (Deci & Cascio, 1972 as cited in Deci & Ryan, 2000; Anderson, Manoogian, & Reznick, 1976, respectively).

1.1.2.1. Self-Determined Motivation and Work-Family Conflict

As mentioned before, although there are plenty of studies that aim to unfold the relationships among work-family conflict and various constructs, motivational aspects of WFC are largely ignored. As to the knowledge of the researcher, there is only one study (see Senecal, Vallerand, & Guay, 2001) which applied SDT to the concept of WFC. Senecal et al. (2001) pointed out that self-determined motivation toward work and family would result in lower levels of family alienation, and in turn, lead to reduced levels of WFC. Confirming their predictions, results showed that both motivation toward work and family activities inversely predicted WFC through perceived family alienation. Although their study provided valuable insight regarding relationships among these variables, the authors examined the effects of autonomous and controlled motivation on general WFC, as a unidimensional construct. Nevertheless, because previous research (e.g., Frone et al., 1992) have already shown that work and family related antecedents of WFC are differentially associated with W-to-FC and F-to-WC, it is important to investigate the impacts of motivational orientations on these dimensions, separately. Moreover, since it is the only study existent in the literature, whether this negative relationship found between

autonomous motivation and WFC will hold true in a different culture with a different sample, is a question that begs answering.

Although the present study agrees with Senecal et al. (2001)'s argument that autonomous motivation will be negatively related to WFC as a whole, it particularly holds that autonomous motivation toward work will be negatively related only to W-to-FC whereas autonomous motivation toward family will be negatively related only to F-to-WC. For, since individuals who have self-determined (autonomous) motivation toward work perform activities required by their work out of interest and internalize their work-related behaviors, they will be less likely to see the work as a source of conflict. In a similar vein, as individuals who score high on self-determined (autonomous) motivation toward family engage in family related activities more volitionally, they will be less likely to perceive these activities as a source of conflict that interferes with their job. On the contrary, these individuals may perceive work demands as interfering with their family performance: pulling them away from the family domain. Conversely, the opposite will hold for those who are high in autonomous motivation toward work. That is, they will perceive home demands as interfering with their work performance; pulling them away from the work domain, which they desire to be involved.

Hence, based on the reasoning above it is predicted that,

H1a: Self-determined (autonomous) motivation toward work will be negatively related to W-to-FC.

H1b: Self-determined (autonomous) motivation toward family will be negatively related to F-to-WC.

A unique prediction made by the present study is that whether an individual experience W-to-FC or F-to-WC may be determined by the combined effects of his/her motivational orientations toward work and family. Above, it is hypothesized that when individuals display higher levels of self-determined (autonomous) motivation toward family, they may be less likely to perceive home demands as

interfering with their work performance, and that these individuals may even believe that not the family, but the work is the cause of the experienced conflict. In fact, this argument may especially hold for individuals who have autonomous (self-determined) motivation toward family but controlled (non-self determined) motivation toward work. Thus, individuals with such a motivational profile may report greater W-to-FC. With a similar reasoning then, individuals who display relatively high levels of self-determined (autonomous) motivation toward work but controlled (non-self determined) motivation toward family may believe family-related issues are the cause of the conflict, and hence report greater F-to-WC. On the other hand, individuals who have controlled motivational profiles, or those who exhibit controlled motivation toward both family and work activities may experience both W-to-FC and F-to-WC, reporting the highest values of WFC. Conversely, individuals with autonomous motivational profiles, or those who have autonomous motivation toward both family and work activities may experience work-life balance and report lowest levels of WFC. Hence, besides direct effects, motivation toward work and motivation toward family may also have interactive effects on WFC.

Based this reasoning stated above, the following hypotheses are formulated;

H2: Perceived WFC will differ as a function of individuals' motivational profiles depending on their autonomus vs. controlled motivations toward work and family. Specifically;

H2a: Individuals with autonomous motivation toward family but with controlled motivation toward work will experience W-to-FC, but not F-to-WC.

H2b: Individuals with autonomous motivation toward work but with controlled motivation toward family will experience F-to-WC, but not W-to-FC.

H2c: Individuals with controlled motivation toward both family and work will experience highest levels of W-to-FC and F-to-WC.

H2d: Individuals with autonomous motivation toward both family and work will experience lowest levels of W-to-FC and F-to-WC.

If it is true that self-determined motivation leads to lower levels of W-to-FC/F-to-WC and determines the type of the conflict to be experienced, then it is important to identify factors that foster self-determined motivation in both work and family contexts.

1.1.3. Work Context and Self-Determined Motivation

As noted before, SDT maintains that certain external factors present in the environment may increase individuals' autonomous motivation via satisfaction of the basic needs. One of these factors that facilitate individuals' autonomous motivation toward work concerns the design or the characteristics of the job they perform at work (Gagne & Deci, 2005). Below, how job characteristics may have an impact on self-determined motivation will be explained by utilizing Job Characteristics Model introduced by Hackman and Oldham (1976, 1980).

1.1.3.1. Job Characteristics Model

Job Characteristics Model (JCM; Hackman & Oldham, 1976, 1980) mainly proposes certain features of the job affect employee's work motivation, and therefore determine important work-related outcomes such as job performance, job satisfaction and burnout. More specifically, JCM holds that there are five core job characteristics that influence employee responses and attitudes toward their job. These are *skill variety*, *task identity*, *task significance*, *autonomy* and *feedback*. The skill variety feature refers to the extent to which a job involves a variety of tasks and activities; allowing the employee to utilize his/her skills and abilities while performing the job. Task identity represents the degree to which a job provides opportunity to perform the entire work; permitting the employee to do the whole job with apparent outcomes. Task significance concerns the significance of the job, referring to the extent that the job has a profound impact on other people's lives. Autonomy is the feature of the job that is associated with the experiences of freedom and independence while doing the job. Lastly, feedback represents the extent to

which the worker is able to get clear and direct information regarding his performance (Hackman & Oldham, 1980).

According to the theory, motivating potential of a job is reflected by its *Motivating Potential Score* (MPS) which is determined by multiplying the core job dimensions. MPS is computed according to the following formula (Hackman & Oldham, 1976, 1980):

$$\text{MPS} = [(\text{Skill variety} + \text{Task Identity} + \text{Task Significance})/3] \times [\text{Autonomy}] \times [\text{Feedback}]$$

Hackman and Oldham (1976) proposed that the higher a job scores on MPS, the more likely that it will lead to internal motivation, and in turn, increase job satisfaction.

JCM (Hackman & Oldham, 1976, 1980) also maintains that these five characteristics give rise to three important, psychological states that an employee experiences during the job. These states are; *experienced meaningfulness*, *experienced responsibility* and *knowledge of results*. Experienced meaningfulness represents the situation that the employee believes that his job is important, valuable, and activities he/she performed on the job are sensible. According to JCM, the job characteristics of skill variety, task identity and task significance directly contribute to the state of experienced meaningfulness. Experienced responsibility for the outcomes refers to the state that the employee feels personal responsibility and accountability for the outcomes of the job. More specifically, when an employee experiences responsibility, he believes that it is his own efforts, decisions and actions that determine the success and failures occurring on the job. This psychological state is directly linked to the autonomy dimension of the job. Lastly, knowledge of results reflects the situation that the employee feels that he is well-informed regarding the outcomes of the job and his performance. This psychological state is directly and closely associated with the feedback dimension of the job (Hackman & Oldham, 1976, 1980).

JCM proposes that as long as a job has these five fundamental characteristics and allows employee to experience three critical psychological states, higher internal

motivation will follow; leading to higher levels of job satisfaction, increased work performance, and lower levels of absenteeism and employee turnover.

An important point made by JCM (Hackman & Oldham, 1976, 1980) is that the relationships between job core characteristics and critical psychological states, and the relationships between critical psychological states and above-mentioned outcomes are moderated by several individual differences variables. Specifically, the model holds that individuals who score high on growth need strength, those who possess adequate knowledge and skills to perform the required tasks, and those who are satisfied with work context characteristics such as compensation, supervision, security etc. will benefit most from the high-level jobs.

Many studies in the literature have provided evidence for JCM. Both Bass (1979) and Lee and Klein (1982) confirmed that features of a job can, indeed, be grouped under the five dimensions as proposed by JCM. In their meta-analysis involving a large number of studies, Fried and Ferris (1987) reported that the five core characteristics were significantly related to corresponding psychological states. The mediating role of the three psychological states were also confirmed by their study showing that experienced meaningfulness, experienced responsibility and knowledge of results were more strongly correlated with the outcomes of job satisfaction, job performance and absenteeism than the job dimensions. Moreover, relevant research revealed that, as predicted by JCM, significant and positive relationships existed between job characteristics and internal work motivation (Brief & Aldag, 1975; Hackman & Lawler, 1971; Hackman & Oldham, 1980; Humphrey, Nahrgang, & Morgeson, 2007; Wall, Clegg & Jackson, 1998). With respect to work outcomes, numerous studies have shown that job characteristics significantly predicted job performance (e.g., Dodd & Gangster, 1996; Wall et al., 1998), job satisfaction (e.g., Brief & Aldag, 1975; Hackman & Oldham, 1975, 1980; Judge, Bono & Locke, 2000; Sultan, 2012), employee turnover (Spector, 1985; Zaniboni, Truxillo, & Fraccaroli, 2013; Zargar, Vandenberghe, Marchand, & Ayed, 2014) and burnout (Humphrey et al., 2007; Koekemoer & Mostert, 2006). And lastly, as far as the moderator variables are concerned, most research focused on the role of growth

need strength and provided evidence that the relationships between job characteristics and work outcomes such as performance and job satisfaction were stronger for individuals with high levels of growth need strength than those who had low levels of growth need strength (Brief & Aldag, 1975; Hackman & Lawler, 1971; Hackman & Oldham, 1976; de Jong, Van der Velde, & Jansen, 2001; Spector, 1985; also see Bilgiç, 2008, Fried and Ferris, 1987, Oldham and Fried, 2016 for reviews).

1.1.3.2. Job Characteristics and Self-Determined Motivation

Although JCM (Hackman & Oldham, 1976, 1980) relies on the classical extrinsic-intrinsic motivation distinction, its arguments are compatible with SDT (Deci & Ryan, 1985; Ryan & Deci, 2000). As mentioned before, JCM holds that autonomy is one of the core job dimensions that promote intrinsic motivation. Similarly, SDT argues that autonomy is a basic need, and that satisfaction of this need is likely to facilitate self-determined (autonomous) motivation. Therefore, it is reasonable to expect that the job characteristics, which allows for exercising autonomy on the job, will satisfy employees' need for autonomy, and in turn, result in higher levels of autonomous motivation. Task identity dimension also require high levels of autonomy, and therefore likely to enhance autonomous motivation because it requires performing the whole job with apperant outcomes. On the other hand, the feedback and skill variety characteristics may satisfy the need for competence. For, knowing that one is doing his job well certainly increases one's feelings of competence. In fact, Deci (1971) found that both challenging activities and positive feedback from supervisors increased autonomous motivation through their fulfillment of the need for competence. Task significance dimension, however, may be more likely to be associated with the need for relatedness, since believing that the job affects other people's lives or works may create a sense of connectedness with others and society as a whole. Satisfaction of the need for relatedness, then, will foster self-determined motivation. Overall, based on the above reasoning, it can be expected that a job that is high in MPS will create an environment that facilitates individual's autonomous motivation.

In the literature, only a handful of studies examined the impact of job characteristics on autonomous motivation as defined in SDT. Yet, they provided direct evidence regarding the aforementioned hypotheses. In their study which examined the relationships between job characteristics proposed by JCM and motivation, Millette and Gagne (2008) found that the job's MPS displayed a significant correlation with intrinsic motivation and was also found to be marginally related to identified motivation. Moreover, researchers found that relative level of autonomous motivation partially mediated the effects of MPS on job satisfaction.

In another study, Gagne, Senecal, and Koestner (1997) reported that task significance and feedback were both directly and indirectly (via perceived meaningfulness and perceived impact of the job, respectively) associated with autonomous motivation. In concordance with these findings, De Coomen, Stynen, Van den Broeck, and De Witte (2013) showed that skill utilization (which can be equated with skill variety dimension of JCM) was positively related to basic need satisfaction and to autonomous motivation, and that the relationship between skill utilization and autonomous motivation was partially mediated by basic need satisfaction. Similarly, Van den Broeck et al. (2008) found that job aspects such as skill utilization, positive feedback, and task autonomy predicted satisfaction of all of the three basic needs, implying these characteristics foster self-determined motivation.

Apart from the above-mentioned studies, research that relied on traditional extrinsic-intrinsic motivation dichotomy provided strong evidence that jobs high on MPS enhanced intrinsic motivation. For example, Hackman and Lawyer (1971) found that jobs' MPS scores were positively associated with internal (intrinsic) motivation. In a similar vein, a study conducted by Hackman and Oldham (1976) on a heterogeneous sample of over 600 employees showed that jobs with highly motivating characteristics facilitated employees' internal motivation. These findings were also replicated by several other studies in the literature (e.g. Brief & Aldag, 1975; Boonzaier, Ficker, & Rust, 2001; Wall et al., 1978). Moreover, in two comprehensive meta-analytic examinations (Fried & Ferris, 1987; Humphrey et al.,

2007) it was documented that job characteristics positively predicted intrinsic work motivation. As put by Gagne and Deci (2005), because it is reasonable to expect that factors that facilitate intrinsic motivation would also prompt internalization of extrinsic motivation, these findings strengthen the position that motivating job characteristics would lead to higher levels of autonomous (self-determined) motivation toward work. Therefore, in the present study, it is expected that,

H3a: There will be a positive relationship between MPS (motivating potential score of a job which is determined by the levels of skill variety, task identity, task significance, feedback and autonomy it provides) and self-determined (autonomous) motivation toward work.

While both JCM and SDT make similar assumptions regarding the relationships between certain job characteristics and motivation, SDT differs from JCM in that job design is not the only variable determining employee motivation. According to SDT, social factors such as supportive interpersonal relationships in the workplace also have a profound impact on employee work motivation (Gagne & Deci, 2005). Therefore, following section will be devoted to the discussion of the ways social support provided by supervisors and coworkers influence employees' motivation toward work.

1.1.3.3. Work Support and Self-Determined Motivation

Work support is generally considered as a job resource that shields employees against the negative effects of work stressors (Bakker & Demerouti, 2007). Indeed, a large number of studies in the literature confirmed the salutary effects of work support; showing its negative relationships to job stress (Seiger & Wiese, 2009), burnout (Fernet, Gagne, & Austin, 2010), anxiety disorders (Frese, 1999), depression (Fusilier, Ganster, & Mayes, 1987), and cardiovascular problems (Johnson & Hall, 1988).

From the perspective of SDT (Deci & Ryan, 1985, 2000), besides these protective effects, support coming from supervisors and colleagues may also act as a facilitator of work motivation by providing nourishment for basic psychological needs. According to Gagne and Deci (2005), supervisors that encourage their subordinates to take initiation regarding work-related tasks, allow them to act freely on tasks in hand, and give chances to participate in decision making process are likely to satisfy employees' need for autonomy and, in turn, enhance their autonomous motivation toward work. Additionally, supervisors may support their employees by providing positive (or relevant) feedback and offering opportunities for self-development (Kovjanic, Schuh, Jonas, Quaquebeke, & Van Dick, 2012). In this way, they may fulfill subordinates' need for competence. Furthermore, productive, effective and successful managers may address employees' competency needs by serving as role models and inspiring the workers (Bass, 1985). Lastly, supervisors who appreciate employees' contributions to organization, show concern for their well-being and treat workers with respect can meet subordinates' need for relatedness. Supervisors may also facilitate identification with work group, and thereby, satisfy employees' need for relatedness by creating harmonious work environments and emphasizing the value of strong relationships among workers (Kovjanic et al, 2012). With a similar reasoning, co-workers contribute to satisfaction of basic needs in the workplace. Colleagues that provide positive feedback and acknowledge the efforts put by their work-mates may fulfill employees' need for competence. Moreover, high quality relationships among workers that based on trust, respect and empathy may create a sense of connectedness with the work-group and/or organization.

Indeed, the relevant literature provided considerable support for the above reasoning. In a study that involved approximately 1000 employees and 23 managers, Deci, Connell and Ryan (1989) showed that training managers to adopt a more autonomy supportive style led to increases in subordinates' levels of job satisfaction and organizational trust. Likewise, Kuvaas (2008) found that perceptions of supervisory support were positively related to employees' intrinsic motivation

toward work. The study further demonstrated that intrinsic motivation mediated the link between perceived supervisory support and employee performance. Consistent with these findings, Richer and Vallerand (1995) found that while supervisors who had a controlling/punitive interactional style undermined employees' autonomous motivation, supervisors with autonomy supportive interactional style enhanced subordinates' self-determined motivation and their feelings of competence. Kovjanic and his colleagues (2012) also revealed that transformational leadership, which is characterized by showing a genuine concern for followers, encouraging independence and self-initiation in followers, and providing meaning for the tasks in hand (Bass, 1985), were significantly associated with satisfaction of the basic needs as proposed by SDT, and in turn, predicted subordinates' job satisfaction and affective commitment to the leader. In a similar study, it was found that supervisors who adopted a transformational leadership style were more likely to satisfy the basic needs of the followers whereas transactional leaders who continuously controlled subordinates' actions and used punishment in case of failures were more likely to threaten subordinates' basic needs (Hetland, Hetland, Andreassen, Pallasen, & Notelaers, 2011). The negative effects of mistreatment from supervisors were also confirmed by Lian, Ferris, and Brown's (2012) research showing that abusive supervision resulted in thwarting of employees' needs, and in turn, predicted organizational deviance. In another study conducted in China, it was shown that while autonomy support in the workplace was positively associated with intrinsic motivation and identified forms of autonomous motivation, it was negatively associated with external motivation and amotivation (Nie, Chua, Yeung, Ryan, & Chan, 2014). Similarly, other studies (Fernet et al., 2010; Fernet, Guay, Senecal, & Austin, 2012; Houkes, Janssen, de Jonge, & Bakker, 2001) found that that workplace social support received from both supervisors and co-workers significantly predicted work motivation.

Hence, based on the ample evidence reviewed above, the present study expects that work support offered by supervisors and co-workers will be positively associated with employees' self-determined motivation toward work. Thus,

employees who perceive their work environments as supportive rather than controlling and punitive, will exhibit higher levels of autonomous motivation.

H3b: There will be a positive relationship between perceived work support and self-determined (autonomous) motivation toward work.

Since the present study also maintains that one's motivation toward his/her family will also affect the degree of F-to-WC experienced by individuals, it seems critical to identify the conditions that may lead to self-determined motivation in family contexts. Therefore, in the subsequent sections, factors that are thought to enhance self-determined motivation in family domains will be discussed.

1.1.4. Family Context and Self-Determined Motivation

As in the case of work environment, family contexts that facilitate basic need satisfaction should also give rise to autonomous motivation. According to Vallerand (1997), individuals develop motivational orientations toward specific life contexts (such as education, work, close relationship and leisure). These context-specific motivation orientations are affected by context related variables giving rise to contextual outcomes. In line with this argument, it seems sound to expect that individuals' motivation toward family related activities such as household tasks, child rearing, family social activities will be determined by family related antecedents. Two of such family-related predictor variables can be perceived spousal (partner) support, and individuals' perceptions of control at home. How spousal support and perceived control may affect individuals' motivation toward family will be explained in the next two sections.

1.1.4.1. Spousal Support and Self-Determined Motivation

Like work support, support offered by spouses may contribute to facilitation of autonomous motivation in family contexts. Spouses that express affection toward their partners, seek for physical proximity with them, concern for their well-being,

and acknowledge their perspectives are very likely to fulfill their partners' need for relatedness, and in turn, enhance their partners' autonomous motivation toward family. On the other hand, spouses that are cold and rejecting toward their partners are likely to hinder their mates' relatedness need satisfaction; leading to lower levels of autonomous motivation. In fact, direct evidence for this proposition comes from Senecal et al.'s (2001) study, which explored the relationships among individuals' perceptions of being valued by one's partner, their feelings of family alienation and displays of autonomous motivation toward family activities. As predicted, researchers found that when people believed that they were valued by their partners, they displayed higher levels of self-determined motivation toward family activities, and, in turn, experienced lower levels of family alienation. Similarly, in a study conducted with French fathers, Bouchard, Lee, Asgary and Pelletier (2007) found that men were more likely to participate in activities involving their children for autonomous reasons when they believed that their involvement was supported and valued by their wives.

In addition, spouses that express confidence in their partners' abilities, offer help regarding family-related tasks and obligations, and provide encouragement in the face of challenges may satisfy their partners' need for competence. Conversely, spouses who continuously criticize or humiliate their partners and blame them in the case failures are likely to undermine their mates' feelings of competence. Overall, Fletcher, and Simpson (2010) demonstrated that individuals were more likely to achieve their self-improvement goals and report high relationship quality when they received both emotional and instrumental assistance from their partners during goal pursuit process. Researchers also demonstrated that negative support from spouses undermined individuals' self-esteem and resulted in poor relationship quality. Likewise, Feeney (2004) reported that individuals who received encouragement from their partners during goal-related discussions reported higher levels of self-esteem and perceived these goals as more attainable after their interactions with the supportive partner. Such positive effects of spousal support on personal goals strivings were also shown by Molden, Lucas, Finkel, Kumashiro and Rusbult (2009).

Taken together, these findings provide support for the assumption that spouses affect their partners' feelings of competency.

Lastly, spouses may satisfy their partners' need for autonomy by respecting their decisions without trying to dominate them or force them to act or think in certain ways, and thereby enhance their partners' self-determined family motivation. Indeed, in a study conducted on university students Ratelle, Simard, and Guay (2013) showed that autonomy support from romantic partner was positively associated with subjects' well-being, which was measured through perceptions of experienced positive and negative affect, academic life satisfaction and life satisfaction in general.

Aside from these studies that emphasized the role of partner support, existing literature also explored the links between basic need fulfillment and relational outcomes. As an example, La Guardia, Ryan, Couchman and Deci (2000) found that individuals were more likely to develop and maintain secure attachments with figures that supported their autonomy, competency and relatedness needs. Researchers further demonstrated that overall need fulfillment in a close relationship was positively associated with relationship satisfaction. Similarly, Hadden, Smith, and Knee (2014) showed that individuals' relatedness need fulfillment in a relationship, not only predicted their own relationship satisfaction, but also their partners' relationship satisfaction. And lastly, in a meta-analytic examination Patrick, Knee, Canevello and Lonsbary (2007) showed that individuals were less likely to develop insecure forms of attachment when their basic needs were met by romantic partners. Moreover, it was documented that perceptions of need satisfaction within romantic relationship positively predicted commitment to the partner and satisfaction with the relationship.

All in all, these findings provide reasonable evidence for the assertions that spouses may help their partners' satisfy their basic needs, and in turn, foster their autonomous motivation regarding family. Therefore, the following hypothesis is generated;

H4a: There will be a positive relationship between spousal support and self-determined (autonomous) motivation toward family.

1.1.4.2. Perceived Control at Home and Self-Determined Motivation

Perceived control refers to individuals' perceptions that they have the ability to alter or affect their environments (Burger, 1989). Studies have shown that people vary in their perceptions of control. While individuals with high perceived control believe that outcomes in life result from their own efforts or capacities, those who have low perceived control think that outcomes are largely determined by factors or forces beyond their control such as luck, fate etc. (Bullers & Prescott, 2001). In this respect, it can be said that perceived control is analogous to the concept of locus of control (Rotter, 1966) albeit the former is a broader term that also encompasses self-efficacy beliefs (Schunk & Zimmerman, 2012). Research has demonstrated the beneficial effects of perceived control on a broad range of outcomes; revealing its positive associations with physical and psychological health (Gallagher, Bentley, & Barlow, 2014; Jacelon, 2007), subjective well-being (Lang & Heckhausen, 2001), adaptive coping (Firth, Frydenberg, & Greaves, 2008), academic performance (Daniels et al., 2014; Skinner, Wellborn, & Connell, 1990), job performance (Spector, 1986), goal attainment (Hortop, Wrosch, & Gagne, 2013), task persistence (Bhanji, Kim, & Delgado, 2016), and optimism (Klein & Helweg-Larsen, 2002).

When the assumptions of SDT (Deci & Ryan, 1985, 2000) are considered, the link between perceptions of control and self-determined (autonomous) motivation seems obvious. Since the need for competence represents humans' desire to have a sense of mastery over the environment, a sense of high control signifies the fulfillment of the need of competence, and hence, likely to facilitate autonomous motivation (Deci & Ryan, 2000; Skinner, 1996). When this reasoning is applied to family contexts, individuals who believe they have control over family-related issues and those who perceive themselves responsible for the positive events happening within the family will be more likely to display family-related autonomous motivation.

Support for these arguments comes from the studies conducted in educational settings. Maybe the most direct evidence comes from d'Ailly's (2003) study that explored the influences autonomy support, perceived control and autonomous motivation on the outcomes of academic performance and the effort spent on a task by using a sample of Chinese students. In the study, the researcher found that adults' autonomy supportive behaviors, children's perceived control concerning academic success and their autonomous motivation toward learning positively predicted academic performance and the efforts they exerted on school tasks. Of more importance to present study, a significant and positive relationship was found between perceptions of control and autonomous motivation toward learning. d' Ailly (2003) also examined the intercorrelations between perceptions of control and the types of motivation proposed by SDT (Deci & Ryan, 1985; Ryan & Deci, 2000). Results yielded that perceived control displayed negative relationships with external and introjected motivation, and showed positive correlations with identified and intrinsic forms of motivation.

Likewise, Patrick, Skinner and Connell (1993) examined the relationships among perceptions of control, self-determined motivation, children's emotions and adaptive behaviors in the classroom. Results revealed that both children's control beliefs regarding academic success and their motivation toward learning task uniquely predicted children's adaptive behaviors and experiences of positive emotions throughout the lecture. Moreover, researchers found a positive and moderate correlation ($r = .52$) between self-determined motivation and perceptions of control. In a similar study, Skinner, Wellborn and Connell (1990) investigated the effects of perceived control and supportive environment on elementary school children's engagement with school tasks (which signifies autonomous motivation) and their academic performance. It was shown that both teachers' supportive behaviors and children's perceptions of control regarding school success contributed to students' engagement with learning activities. Furthermore, it was found that the effects of perceived control on performance were partially mediated by students'

engagement with school tasks. In the study, researchers also examined the relationships between engagement and children's' attributions for success and failure. Results showed that students who attributed their performance outcomes to external factors (e.g., luck, powerful others) and those who believed that they lack the ability to succeed were less likely to show motivated behaviors (engagement) for school activities. Conversely, students who attributed positive performance outcomes to internal factors (ability, effort) were more likely to display motivated behaviors (engagement) in the classroom.

In a more recent study, Amoura, Berjot, and Gillet (2013) showed that the variable desire for control, which can be defined as a personality trait that reflects an individual's desire to have a control over his/her environment (Burger 1992), positively predicted students' autonomous motivation toward academic work through its effects on need for competence. Similarly, Amoura, Berjot, Gillet and Altıntaş (2014) found that students' desire for control and perceptions of control were positively associated with students' autonomous academic motivation and conjointly predicted their well-being.

Overall, these findings support the idea that perceived control contributes to enhancement of self-determined motivation. Hence, on the basis of rationale and the findings stated above, it is expected that;

H4b: There will be a positive relationship between perceived control within the family environment and self-determined (autonomous) motivation toward family.

Although research on WFC has established that experience of conflict leads to undesirable consequences in both work and family domains, studies examining the relative importance of W-to-FC and F-to-WC in predicting work and family related outcomes have yielded incompatible results. In an attempt to elucidate these contradictory findings, the current study also explores the effects of these two forms of conflict in both domains.

1.1.5. Outcomes of Work- Family Conflict

While the present study intends to expand the existing research by exploring the relationships between self-determined motivation and work-family conflict, it also aims to examine the consequences of work-family conflict. Hence, the present study utilizes job satisfaction, family satisfaction, emotional exhaustion, and life satisfaction as the major outcomes of work-family conflict. In the following sections, how work-family conflict may affect these outcomes will be explained in detail.

1.1.5.1. Relationships Between Work-Family Conflict, and Job and Family Satisfaction

Job satisfaction reflects individuals' positive feelings about their jobs (Spector, 1997) and has been one of the most commonly examined outcomes of WFC (Bruck, Allen, Spector, 2002). The general assumption is that frequently experienced conflict between work and family roles decreases individuals' satisfaction with these roles.

This assumption has been confirmed by numerous studies showing the negative links between WFC and job satisfaction (Adams, King, & King, 1996; Allen et al., 2000; Aryee, 1992; Bruck et al., 2002; Carlson et al., 2000; Judge et al., 2006; Lapierre et al., 2008; Netemayer, Boles, & McMurrian, 1996; Parasuraman & Simmers, 2001; Lu et al., 2009; Thomas & Gangster, 1995). Moreover, in a meta-analytic study Kossek and Ozeki (1998) reported that job satisfaction was negatively associated with both WFC ($r = -.23$), and its facets: W-to-FC ($r = -.27$) and F-to-WC ($r = -.18$). These findings were replicated by other meta-analytic inquiries (Allen, Herst, Bruck, & Sutton, 2000; Amstad et al., 2011; Shockley & Singla, 2011) which found negative associations between WFC and job satisfaction. Studies conducted in Turkey also revealed similar results and showed that increased levels of WFC were associated with decreased levels of job satisfaction (Öcal, 2008; Tubin, 2007; Yüksel, 2005).

Like job satisfaction, family satisfaction has also received a great deal of attention from scholars. Several studies investigated examined effects of WFC on family satisfaction and found negative associations between these constructs (Aryee, Luk, Leung, & Lo, 1999; Beutell & Wittig-Berman, 1999; Carlson & Kacmar, 2000; Frye & Breugh, 2004; Lapierre et al., 2008, Üzümcüoğlu, 2013). Additional evidence for these results was provided by Amstad et al.'s (2011), and Shockley and Singla's (2011) meta-analytical studies which reported negative correlations between family satisfaction, and both W-to-FC and F-to-WC dimensions.

On the basis of aforementioned results, it is expected that WFC will be negatively related to both job and family satisfaction. Yet, because the present study utilizes WFC as a bidimensional construct which involves both W-to-FC and F-to-WC, the relationships among these two facets of WFC, and job and family satisfaction will be discussed more thoroughly in the subsequent section (See Section 1.1.6.3).

The current study maintains that the negative effects of WFC are not confined to reductions in role satisfaction. It also asserts that WFC will result in heightened levels of emotional exhaustion. Therefore, in the following section, the expected relationships between WFC and emotional exhaustion will be discussed.

1.1.5.2. Relationships Between Work-Family Conflict, and Emotional Exhaustion

Emotional exhaustion is generally considered as the core component of burnout (Wright & Cropanzano, 1998), and characterized by the symptoms of lack of energy and feelings of emotional depletion (Maslach, Jackson, & Leiter, 1996). Research accumulating for nearly forty years has well-established the detrimental impacts of emotional exhaustion (and also burnout) on employee well-being and organizational outcomes documenting its positive links with depression (e.g., Leiter & Durup, 1994), psychosomatic complaints (e.g., Zapf, Vogt, Seifert, Mertini, & Isic, 1999), increased cortisol levels (e.g., Pruessner, Hellhammer, & Kirschbaum, 1999), turnover intentions (e.g., Wright & Cropanzano, 1998), absenteeism (e.g.,

Schaufeli, Bakker, & Van Rhenen, 2009), reduced job satisfaction (Maslach et al., 1996), and decrements in performance (e.g., Wright & Cropanzano, 1998).

As previously mentioned, WFC is considered a type of role conflict and source of stress (Greenhaus & Beutell, 1985). Therefore, it seems reasonable to expect that high WFC leads to feelings of emotional exhaustion. For, continuous struggle to meet both work and family demands may lead to enhanced levels of psychological strain, and consume one's physical and emotional resources, leaving the individual feeling frustrated and emotionally drained (Grandey & Cropanzano, 1999). A growing body of studies has provided support for this assumption. For instance, in a study conducted on nurses, Burke and Greenglass (2001) found that both workload and WFC significantly predicted emotional exhaustion. Positive associations between WFC and emotional exhaustion were also reported by several other studies (Amstadt et al., 2011; Karatepe and Tekinkuş 2006; Kossek & Ozeki, 1998; Peeters, Montgomery, Bakker, & Schaufeli, 2005; Rubio, Osca, Recio, Urien and Perio, 2015; Rupert, Stevanovic, & Hunley, 2009). Moreover, Baeriswyl, Krause and Schwaninger (2016) examined the effects of support and workload on emotional exhaustion, and showed that their impacts on emotional exhaustion were partially mediated by work-family conflict.

Based on these findings, it is predicted that WFC will be positively related to emotional exhaustion. As in the case of satisfaction outcomes, more specific information regarding the predicted relationships concerning W-to-FC and F-to-WC dimensions, and emotional exhaustion will be presented in the following section (See Section 1.1.6.3).

1.1.5.3. Relationships Among WFC Dimensions, Emotional Exhaustion, Job and Family Satisfaction

Although researchers generally concur that WFC has detrimental impacts on a wide range of outcomes, disagreement exists regarding which form of WFC plays a dominant role in predicting work and family related variables. Frone, et al. (1992) have adopted a cross-domain relationship approach and argued that the conflict

arising from one domain (e.g., work) should primarily affect the outcomes in the other domain (e.g., family). For, according to the researchers, overinvolvement in a given role depletes individuals' resources required for the other role, and as a result, quality of experiences in the second role decreases. From the perspective of cross-domain hypothesis, then, W-to-FC should display stronger relationships with family-related outcomes whereas F-to-WC should display stronger relationships with work-related outcomes.

On the other hand, some researchers (e.g., Frye & Breugh, 2004; Grandey, Cordeiro, & Crouter, 2005; Voydanoff, 2001) have favored the matching approach (Cohen & Wills, 1985) and asserted that the conflict arising from one domain (e.g., work) should primarily affect the outcomes in the same domain (e.g., work). These researchers have claimed that when individuals experience a conflict they tend to blame the source of the conflict and develop negative attitudes towards it. As an example, when a person is overwhelmed by the work demands and perceives that s/he can not devote enough time and effort to his/her family, s/he will be likely to blame the job for draining his/her resources. Eventually, this will lead to reductions in job satisfaction. Therefore, according to matching hypothesis, W-to-FC should be more closely related to work domain outcomes whereas F-to-WC should be more closely related to family domain outcomes.

Up to date, studies that aimed to test these hypotheses have revealed incompatible results, providing support for both approaches. For instance, consistent with the cross-domain hypotheses, Frone et al. (1997) showed that while W-to-FC negatively predicted family performance, F-to-WC negatively predicted job performance. In a similar vein, Frone et al. (1992) found that F-to-WC was a significant determinant of job distress. Carlson and Kacmar (2000) examined the relationships among WFC dimensions, and job and family satisfaction, and found that W-to-FC was significantly related to family satisfaction. Negative associations between W-to-FC and family satisfaction were also reported by Judge et al. (2006), and Aycan and Eskin (2005). Lastly, in a meta-analytic examination of cross-domain

effects of WFC facets on work and family related variables, Ford, Heinen, and Langkamer (2007) showed that W-to-FC was significantly related to family satisfaction whereas F-to-WC was significantly related to job satisfaction.

On the other hand, there are also studies yielding results that have favored the matching hypothesis. For example, in a study that explored the associations among WFC dimensions, work-related variables of job satisfaction and job stress, and family related variables of marital satisfaction and marital risk, Voydanoff (2001) found that while W-to-FC was more closely related to the outcomes of the work domain than F-to-WC, F-to-WC was more closely related to the outcomes of the family domain than W-to-FC. In congruence with these results, Lapierre et al. (2008) showed that both strain and behavior-based W-to-FC were more strongly associated with job satisfaction than with family satisfaction. On the other hand, the opposite pattern of results was found for F-to-WC. More specifically, it was shown that time, strain and behavior based types of F-to-WC were more strongly associated with marital satisfaction. In a similar vein, Wayne, Musisca and Fleeson (2002) reported a higher association between W-to-FC and job satisfaction than between W-to-FC and family satisfaction. Similar patterns of results were obtained in the study for the relations among F-to-WC, family satisfaction and job satisfaction. That is, F-to-WC yielded a much stronger relationship with family satisfaction than with job satisfaction. Furthermore, in recent, more comprehensive meta-analytic inquiries that simultaneously tested the assumptions of both cross-domain and matching approaches, Amstad et al. (2011), and Shockley and Singla (2011) documented that W-to-FC was a more robust predictor of work satisfaction than of family satisfaction whereas F-to-WC was a stronger predictor of family satisfaction than of work satisfaction. These findings were also consistent with the Kossek and Ozeki's (1998) meta-analysis's results that yielded a higher correlation between W-to-FC and job satisfaction than between F-to-WC and job satisfaction

Since there seems to be more support for the matching approach, the present study basically follows the matching hypothesis and affirms that while W-to-FC will be negatively associated with job satisfaction, F-to-WC will be negatively associated with family satisfaction.

A similar reasoning can be applied to the relationships among WFC facets and emotional exhaustion. Although, in the literature, it is generally considered that emotional exhaustion stems from excessive work demands, and thus regarded as relevant to work contexts, it is equally possible that individuals may experience emotional depletion due to excessive family demands, and be exhausted by their family lives.

Therefore, on the basis of the theoretical reasoning and empirical evidence reviewed above, the following two hypotheses are generated;

H5: W-to-FC will be negatively related to a) job satisfaction and positively related to b) work-related emotional exhaustion (exhaustion at work).

H6: F-to-WC will be negatively related to a) family satisfaction and b) family-related emotional exhaustion (exhaustion at home).

While the current study primarily draws upon the matching hypothesis, it does not deny that cross-domain relationships may occur. Relying on the relevant findings mentioned above, it is also expected that W-to-FC will be related to family satisfaction and F-to-WC will be related to job satisfaction. Including these cross-domain relationships in the study may not only improve the model fit but also allows for the comparison of predictive powers of W-to-FC and F-to-WC on both work and family-domain outcomes. Hence, it is predicted that;

H7: W-to-FC will be negatively, yet weakly, related to family satisfaction.

H8: F-to-WC will be negatively, yet weakly, related to job satisfaction.

1.1.5.4. Life Satisfaction

Life satisfaction has been frequently used as an indicator of general well-being, and refers to the degree to which individuals feel happy about their lives as a whole (Beutell & Wittig-Berman, 1999). Since work and family represent two major spheres in one's life, satisfactions in these domains will probably contribute to overall life satisfaction (Rice, Frone, & McFarlin, 1992). Therefore, it is expected that job and family satisfaction will have an additive impact on individuals' satisfaction with life. These arguments are supported by prior research that found positive relationships between job satisfaction and life satisfaction (Ahmad, 1996; Beutell & Wittig-Berman, 1999; Carlson & Kacmar, 2000; Haar, Russo, Suñe, & Ollier-Malaterre, 2014; Lapierre et al., 2008; Rice et al., 1992) and between family satisfaction and life satisfaction (Ahmad, 1996; Beutell & Wittig-Berman, 1999; Carlson & Kacmar, 2000; Lapierre et al., 2008; Margolis & Myrskylä, 2013; Rice et al., 1992). Parasuraman, Greenhaus and Granrose (1992) examined the relationships among job and family satisfaction, and life stress, and showed that higher levels of job satisfaction and family satisfaction were associated with lower levels of life stress. Moreover, in several studies (e.g., Ahmad, 1996; Beutell & Wittig-Berman, 1999; Carlson & Kacmar, 2000; Lapierre et al., 2008) the negative effects of WFC on life satisfaction were found to be mediated by decreased levels of job satisfaction and family satisfaction.

Hence, based on these results, it is predicted that;

H9: Life satisfaction will be positively associated with a) job satisfaction and b) family satisfaction

1.1.6. Direct Relationships Between Antecedents of Self-Determined Motivation and WFC Outcomes

Although Hackman and Oldham (1976, 1980) claimed that job characteristics should exert their impacts on important work-related outcomes through the experience of critical psychological states, several studies (Liden, Wayne, &

Sparrowe, 2000; Renn & Vanderberg, 1995; Wall, Chris, & Jackson, 1978), including two meta-analyses, (Behson, Eddy, & Lorenzet, 2000; Fried & Ferris, 1987) showed that the mediating role of psychological states is only partial, and job characteristics also have direct effects on job satisfaction. Therefore, it is likely that job characteristics will be positively related to job satisfaction.

Significant and negative relationships between job characteristics and emotional exhaustion have also been documented by numerous studies. In a study conducted on nurses, Jansen, Kerkstra, Abu-saad, and Van der zee (1996) found that job characteristics of autonomy, skill variety and task significance were associated with reduced feelings of emotional exhaustion. Similarly, Kelloway and Barling (1991) reported that job autonomy, task identity and feedback dimensions displayed negative relationships with emotional exhaustion. Griffin, Hogan and Lambert (2012) showed that skilly variety and autonomy components of the job significantly decreased the levels of emotional exhaustion experienced by correctional officers working in prisons. Moreover, in studies that relied on Job Demands-Resources Model (JD-R; Bakker, Demerouti, & Schaufeli, 2003) job autonomy has been consistently found to be negatively linked to emotional exhaustion (e.g., Demerouti, Mostert, & Bakker, 2010; Schaufeli & Bakker, 2004; Xanthopoulou, Bakker, Demerouti, & Schaufeli, 2007). Hence, it is likely that job characteristics will be negatively related to emotional exhaustion experienced at work.

Based on the findings stated above, it is hypothesized that;

H10: Job characteristics will be a) directly and positively related to job satisfaction, b) directly and negatively related to work-related emotional exhaustion (exhaustion at work).

Work support has been generally conceptualized as a job resource that enhances job satisfaction and alleviates the feelings of emotional exhaustion/burnout (Bakker et al., 2003). The positive effects of work support on job satisfaction have been demonstrated by a vast number of number studies that found significant and

positive relationships between these constructs (Eisenberger, Cummings, Armeli, & Lynch, 1997; Fernet et al., 2010; Griffin, Patterson, & West, 2001; Gözükara & Çolakoğlu, 2015; Kale, 2015; Kula & Güler, 2014; Shore & Tetrick, 1991; Tang, Siu, & Francis Cheung, 2014). Relevant research has also found negative relationships between perceived work support and emotional exhaustion, providing evidence for the strain reducing effect of work support (Baeriswyl, Krause, & Schwaninger, 2016; Bakker et al., 2003, Baruch-Feldman, Brondolo, Ben-Dayan, & Schwartz, 2002; Burke, Greenglass, Schwarzer, 1996; Halbesleben, 2006; Tayfur & Arslan, 2013; Yürür & Sarıkaya, 2012). Therefore, in the present it is proposed that;

H11: Perceived work support will be a) directly and positively related to job satisfaction, b) directly and negatively related to work-related emotional exhaustion (exhaustion at work).

Like work support, the support offered by one's partner has been associated with positive outcomes. Numerous studies in close relationships research showed that spousal support enhanced individuals' marital/ family satisfaction (Acitelli & Antonucci, 1994; Cutrona & Suhr, 1994; Dehle, Larsen, & Landers, 2001; Julien & Markman, 1991; Overall, Fletcher, & Simpson, 2010; Xu & Burleson, 2004). Evidence concerning the beneficial role of spousal support in reducing emotional exhaustion, on the other hand, mostly comes from the research on work-family interface. Studies have found that higher levels of perceived support were associated with lower levels of exhaustion (Kulik & Rayyan, 2003; Halbesleben, Zellars, Carlson, Perrewe, & Rotondo, 2010; Halbesleben, Wheeler, & Rossi, 2011; Rupert, Stevanovic, & Hunley, 2009). Based on these findings, it is predicted that;

H12: Spousal support will be a) directly and positively related to family satisfaction, b) directly and negatively related to family-related emotional exhaustion (exhaustion at home).

As previously mentioned, individuals' perceptions of control over their environments has been associated with adaptive outcomes. Although only a limited number of studies examined the effects perceived control on relationship outcomes, there is some evidence for the assumption that perceptions of high control increases family satisfaction. In an experimental study on approximately ninety married couples, Miller, Lefcourt, Holmes, Ware, and Saleh (1986) found that couples who were high on internal locus of control approached to marital conflicts in a more constructive manner, and used more effective communication and problem solving styles during their discussions with partners. Researchers also demonstrated that individuals with internal locus of control were more likely to be satisfied with their marriages. Similarly, Madden and Janoff- Bulman (1981) found that women who believed that they could effectively resolve the conflicts with their husbands and who had a sense of control regarding the resolution of family-related problems reported higher levels of marital satisfaction. In another study, Madden (1987) showed that individuals who perceived that they had control over family related decisions and activities were more likely to be satisfied with their marriages. On the other hand, Camp and Ganong (1997) examined the relationship between locus of control and marital satisfaction on married dyads and found that couples' with internal locus of control orientations reported experienced greater marital satisfaction. These findings also concurred with the Myers and Booth's (1999) that documented positive associations between internal locus of control orientation and favorable perceptions regarding one's own marriage.

Research concerning the relationship between perceived control and emotional exhaustion has generally relied on the Job Demand-Control Model (JD-C; Karasek, 1979), and mostly conducted in work-settings. JD-C Model posits that two characteristics of work environments; namely, job demands (workoverload, time pressure, conflict) and control over the job (also referred as decision latitude) interact to determine employee well-being. According to the model, while jobs that involve high demands and lack control (high-strain jobs) lead to detrimental outcomes such

as psychological strain, distress, and burnout (emotional exhaustion), those which are high in demands and control (active jobs) promote employee motivation and well-being. Hence, JD-C assumes that perceptions of job control buffer employees against the destructive effects of job demands. Although this assumption has been challenged by several studies which failed to find interaction effects (e.g., Junge de, & Landeweerd, 1993; Fletcher & Jones, 1993; Warr, 1990), it has been consistently showed that perceptions of job control directly impact employees' health by reducing the experiences of fatigue, strain and burnout (de Rijk, Le Blanc, Schaufeli, & de Junge, 1998; Häusser, Mojzisch, Niesel, & Schulz-Hardt, 2010; Karasek, 1979; Melamed, Kushnir, & Meir, 1991; Teuchmann, Totterdell, & Parker, 1999; Park, Jacob, Wagner, & Baiden, 2014). When these findings are taken into account, it is likely that the negative association between perceived control and emotional exhaustion will also hold true in family contexts. That is, individuals who perceive that they have control over family-related events will be less likely to suffer from family-related emotional exhaustion.

Hence relying on the relevant literature discussed above, it is expected that;

H13: Perceived control at home will be positively related to a) family satisfaction, and negatively related to b) family-related emotional exhaustion (exhaustion at home)

As mentioned before, studies that examined the associations between the dimensions of WFC and satisfaction outcomes revealed inconsistent results. Moreover, although it was shown that work-family conflict resulted in job and family dissatisfaction, the magnitudes of these relationships varied greatly across individual studies (Kossek & Ozeki, 1998). According to Kossek and Ozeki (1998), the differences in the strength of the correlations may result from the fact that several moderator variables are involved in these relationships, affecting the impacts of W-to-FC and F-to-WC on job and family satisfaction. One possible moderator variable

that may influence the proposed links between the facets of WFC and satisfaction related constructs is the identification with work (family) role. The ways how role identification acts as a moderator variable will be explained in the following sections from the framework of Identity Theory.

1.1.7. Identity Theory

Identity Theory (Stryker, 1980, 1987; Stryker & Serpe, 1982) holds that people develop multiple identities depending on the roles that they occupy. Like Social Identity Theory (Tajfel & Turner, 1979, 1986), Identity Theory proposes that the self has a reflexive function which allows individuals to classify themselves in relation to certain social categories, groups or roles. While this classification of the self is termed as self-categorization in Social Identity Theory, it is referred as identification in Identity Theory (Stets & Burke, 2000).

Although there is a substantial conceptual similarity between Social Identity Theory and Identity Theory, Identity Theory differs from Social Identity Theory in that; Identity Theory examines the self in terms of the social roles whereas the latter focuses on the social group processes in formation of identity (Desrochers, Andreassi, & Thompson, 2004; Stets & Burke, 2000). According to Identity Theory, identities are determined by the responses given to the question of “*Who am I?*” (Stryker & Serpe, 1982, p.206). The responses may include “*I am a Ph. D. student*”, “*I am a daughter*”, “*I am a lecturer*”, “*I am an activist*” and so on; each reflecting an identity. By means of social interactions with others, individuals attach meanings and values to these roles and the perceived importance of these roles determine the centrality of each role to one’s self concept.

Identity Theory states that meanings associated with roles not only form the basis of identity but also determine goals, expectations and prescribe desired behaviors regarding these roles. Individual’s performance in these domains, then, contributes to self-evaluations and attitudes toward the self (Burke & Reitzes, 1981). Therefore, from the perspective of Identity Theory, there are close relationships between importance given to these roles and the individual’s behaviors associated with these roles.

A relevant proposition made by the theory is that multiple roles, which an individual possesses, are organized hierarchically in one's self system. The rank of a role in this hierarchy reflects the salience of that role. While roles that are in congruence with societal expectations, rewarding in several ways, and that are performed competently are located in the upper levels of this identity hierarchy, roles which are perceived as costly, socially undesirable and incompetently performed are placed in the lower levels of the hierarchy. The location of the role along the hierarchy, then, determines the salience of that role for the individual (Burke & Reitzes, 1981; Stryker, 1980). Hence, the more meaning and purpose attached to a role, the more likely that the role will be placed in the upper levels of hierarchy, and therefore the more likely that it will be salient for the individual.

According to Stryker and Serpe (1982), the salience of the role affects the degree of individual's preoccupation with, and investment and commitment to that role, which also implies that the more salient the role, more likely that it will predict the relevant behavior (Hogg, Terry & White, 1995). In fact, the theory argues that this is why people who occupy the same roles may behave differently in similar contexts (Hogg et al., 1995). Identity Theory has been utilized in several contexts and relevant literature revealed that role identification was significantly associated with performance (Burke & Reitzes, 1981), employee creativity (Farmer, Tierney, & Kung-Mcintyre, 2003), feelings of distress (Stryker and Serpe, 1982; Thoits, 1992) and, of more importance to present paper, work-family conflict (e.g., Bagger, Li, & Gutek, 2008).

1.1.7.1. Moderating Effects of Identification with Work (Family) Role in the Relationships between WFC Dimensions, and Job and Family Satisfaction

The Identity Theory (Stryker, 1980, 1987; Stryker & Serpe, 1982) have been applied to the study of WFC by several researchers under the terms "*role salience*"

(e.g., Bıçaksız, 2009; Greenhaus & Beutell, 1985), “*role involvement*” (e.g., Frone et al. 1992; Parasuraman & Simmers, 1991), “*role commitment*”, “*life role values*” (e.g., Carlson & Kacmar, 2000) and “*role centrality*” (e.g., Carr et al., 2008).

Studies that examining the direct effects of role identification on WFC consistently showed that job and family involvement contributed to the experiences of W-to-FC and F-to-WC, respectively (Adams et al., 1996; Beutell & Wittig-Berman, 1999; Byron, 2005; Frone et al., 1992; Parasuraman & Simmer, 2001). Studies have also investigated the moderator effects of role identification though the analyses were mostly confined to the relationships between WFC and its antecedents. For example, Day and Chamberlain (2006) found that the effects of irregular work schedules on work-parent conflict were exacerbated by high parental role commitment. Frone and Rice (1987), on the other hand, examined the joint effects of job and family involvement on individuals’ perceived levels of WFC. Similarly, Greenhaus and Beutell (1985) suggested that individuals with high work and family role salience would be more responsive to role stressors and more likely to experience high levels of WFC. Taken together, these findings signify that role identification is a crucial construct which can greatly influence the relationships postulated by the present study.

In the previous section, it is hypothesized that although the effects of WFC on proposed outcomes will be stronger within domains, cross-domain relationships between F-to-WC and job satisfaction, and W-to-FC and family satisfaction are also expected. Following the assumptions of Identity Theory (Stryker, 1987; Stryker & Burke, 2000) the present study makes an additional prediction that these cross-domain relationships will differ as a function of people’s identification with their roles. According to Thoits (1992), any kind of stress associated with one’s salient role may have more detrimental effects on personal well-being because it is more likely to be perceived as a threat to one’s identity. Therefore, relying on the assumption of Thoits (1992), it is maintained that for individuals who are highly identified with their work role, the relationship between W-to-FC and family satisfaction will be stronger than those who are low on work-role identification. For,

since work is a central aspect of identity, any frustration experienced in the work domain may have greater impact on family-related outcomes for these individuals. Conversely, when the individual's identification with his/her work role is low, demands or problems associated with work may not have such strong effects on family satisfaction. For, since these individuals do not define themselves in terms of their work role, they will be less likely to perceive the problems with work domain as serious, and therefore less likely to allow these issues to disrupt their family life. Thus, low identification with the work role may buffer individuals against stressors within work domain, preventing the negative spillover from work context to family context. In a similar vein, for individuals who are high on family role identity, the relationship between F-to-WC and job satisfaction will be stronger than for those with low family identity. For, since family is the key aspect of self-identity for these individuals, any problem within the family domain will be more likely to spillover work context, affecting work-related outcomes. On the other hand, for individuals who are low on family role identification the proposed relationship between F-to-WC and job satisfaction will be weaker.

Studies that examined the moderating effects of role salience on the relationships between WFC and its outcomes revealed inconsistent findings (Bhowon, 2013; Bagger et al., 2008; Carr et al., 2008; Greenhaus, Parasuraman, & Collins, 2001; Noor, 2004). Yet, there is some research providing evidence for the argument presented above. Simons (1992) found that strains relevant to parental role resulted in greater distress and anxiety among the individuals who had high parental commitment. Carlson and Kacmar (2000) reported that the negative relationship between family role conflict and family satisfaction was magnified under the conditions of high work centrality. Lastly, on a sample of employed women, Noor (2004) showed that the effect of W-to-FC on psychological well-being was stronger for those who were high in work role salience.

Thus, based on the reasoning and relevant findings mentioned above, the following hypotheses are formulated;

H14: The effects of W-to-FC on family satisfaction will be moderated by work role identification, such that the negative relationship between W-to-FC and family satisfaction will be stronger for the individuals who are high on work role identification than for those who are low on work role identification.

H15: The effects of F-to-WC on job satisfaction will be moderated by family role identification, such that the negative relationship between F-to-WC and job satisfaction will be stronger for the individuals who are high on family role identification than for those who are low on family role identification.

1.2. The Proposed Model of Work Family Conflict

Building on the prior works in the literature (e.g., Carlson & Kacmar, 2000; Deci & Ryan, 1985, 2000; Frone et al., 1997; Hackman & Oldham, 1980; Millette & Gagne, 2008; Senecal et al., 2001) hypotheses generated in the previous sections have been integrated into one comprehensive model of work-conflict (see Figure 2a.). The proposed model involves possible antecedents and outcomes of WFC for both work and family domains. With respect to work domain, it is expected that both job characteristics and work support will contribute to the feelings of autonomous motivation toward work. Autonomous motivation toward work, in turn, is expected to predict lower levels of W-to-FC, and W-to-FC, in turn, will result in reduced job satisfaction and enhanced emotional exhaustion at work. However, as previously mentioned (see Section 1.1.8.), it is predicted that job characteristics and work support will also have direct effects on job satisfaction and emotional exhaustion at work. Therefore, the proposed direct effects of job characteristics on job satisfaction and work-related emotional exhaustion, as well as the direct effects of work support on job satisfaction and work-related emotional, are also included in the model. That is, although it is suggested that both autonomous motivation toward work and W-to-FC will mediate the relationships between work related antecedents and outcomes, it is maintained that their mediating effects on these relationships will be partial.

For the family domain, parallel relationships are expected. It predicted that both spousal support and perceived control at home will contribute to the feelings of autonomous motivation toward family. Autonomous motivation toward family, then, is expected to predict lower levels of F-to-WC, and F-to-WC, in turn, will lead to decreased family satisfaction and greater emotional exhaustion at home. Since it is expected that both spousal support and perceived control at home will also have direct impacts on family satisfaction and family-related emotional exhaustion (see Section 1.1.8.), paths representing these direct effects of spousal support and perceived control are, again, added in the model. Hence, as in the case of work domain, it is expected that both autonomous motivation and F-to-WC will partially mediate the relationships among the family related antecedents and outcomes.

Eventually, the model predicts that both job and family satisfaction will contribute to life satisfaction. In other words, it is assumed that both W-to-FC and F-to-WC will exert their negative influences on life satisfaction, through reduced levels of job and family satisfaction. Lastly, since the relevant research (e.g., Gutek et al., 1991) established that W-to-FC and F-to-WC are reciprocally related with each other, a path reflecting the bi-directional relationship among these two facets is also included in the model. The *Hypothesis 2*, and *sub-hypotheses 2a-2d*, are not depicted in the figure because they concern the interactive effects of motivational orientations on WFC dimensions. On the other hand, proposed cross-domain effects of W-to-FC and F-to-WC on context-specific satisfaction outcomes (*Hypotheses 7 and 8*), and the moderating role of work / family role identifications in these relationships (*Hypotheses 14 and 15*) are separately shown in Figure 2b.

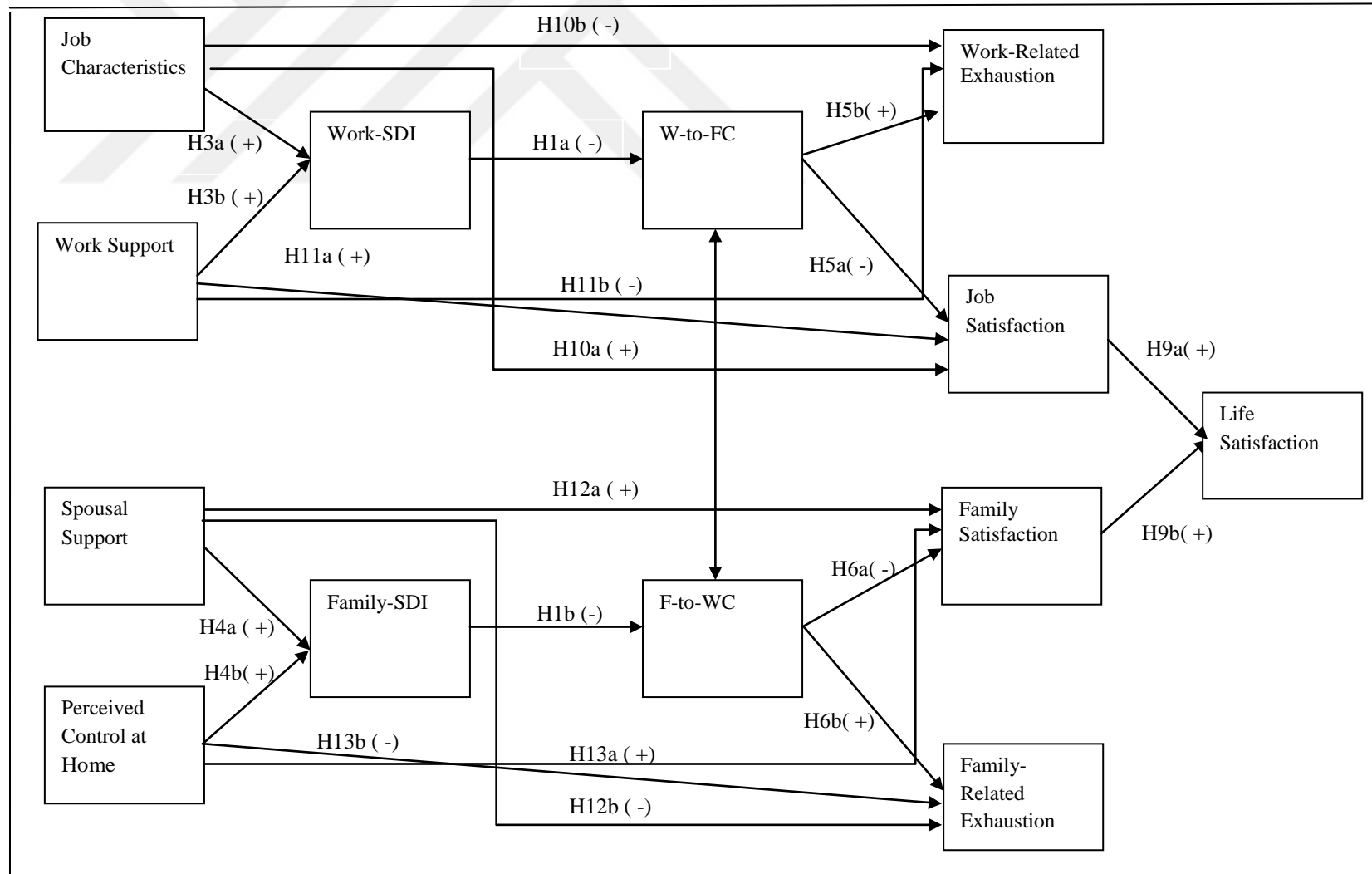

Figure 2a The Proposed Model of Work-Family Conflict

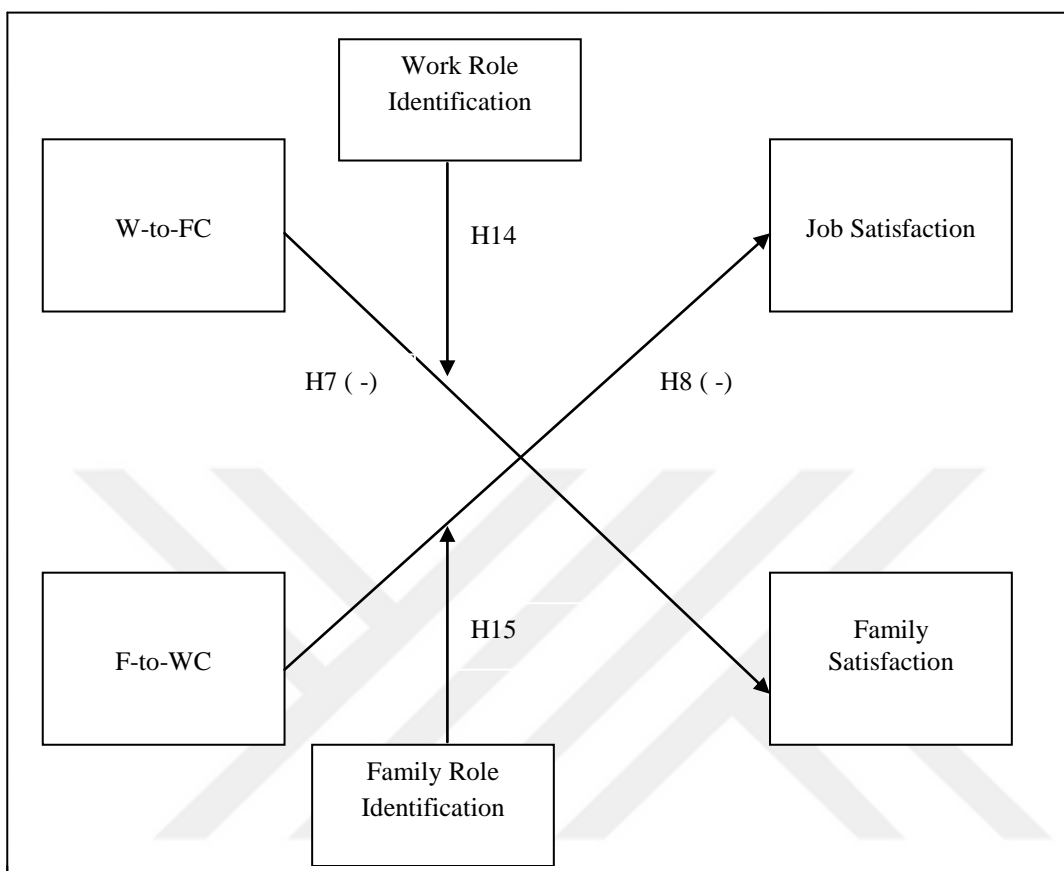

Figure 2b The Proposed Model of Work-Family Conflict

CHAPTER 2

PILOT STUDY

A pilot study was carried out to evaluate the psychometric properties of the scales to be used in the main study. A series of Explanatory Factor Analyses (EFA) and reliability analyses were performed to examine the factor structures and the internal consistencies of the measures. The method, procedure and the information about the measurement instruments of the pilot study, as well as the results concerning the aforementioned analyses are presented under the subtitles 1) Method, 2) Results, and 3) Discussion

2.1. Method

2.1.1. Sample

The sample of the pilot study comprised 407 individuals from dual-earner families who had at least one child less than 18 years old. Hence, only the individuals who met the following the criteria of 1) being married 2) currently working and holding a white or blue- collar job in either private or public sector, 3) having a spouse who is also employed, and lastly 4) having at least one child younger than 18 were included in the study. Among these, 260 (63.9 %) were mothers, whereas 147 (36.1 %) were fathers. Age of the participants changed from 26 to 59 with *Mean* = 40.06 and *S.D.* = 6.55. Of the participants who provided information, the majority of them (267, 65.5%) held bachelor's degree, 20.6% (84) of them had high school degree, 9.1 % (37) of them had graduate degree, and 4.4.% (18) of them had elementary school degree.

The average tenure was approximately 15 years; (minimum: 2 weeks- maximum: 35 years; *S.D.* = 7.86). While 239 (58.7%) of the participants reported that they had no flexible working hours, 125 (30.7%) of them reported that they were flextime workers. On the other hand, 39 (9.6%) participants indicated that they

worked with a partially flexible schedule. Four (1%) people did not provide information about their working hours.

Most of the participants (266, 55.5%) had two children, one hundred and fifty five (155; 38.1%) had one child. On the other hand, there were 23 (5.7%) individuals with three children and four (0.7%) individuals with four children. Participants' youngest children's ages ranged from 0 to 17. Among the participants who provided information, 247 individuals (60.7%) received extra support for household tasks and 184 (45.2%) individuals received childcare support.

2.1.2. Procedure

After an approval was obtained from Human Subjects Review Committee of the university, data were attained by utilizing the snowball sampling technique. Questionnaire packages, which encompassed the study's measures, were delivered to students of psychology department in a private university in self-stamped envelopes along with informed consents and debriefing forms (See Appendix A1, A2). Students were asked to distribute the surveys to individuals in dual earner families with having at least one child younger than 18 years old. Each student received maximum three questionnaires and earned one bonus point for delivering these surveys.

Five hundred and twenty questionnaires were delivered and 440 of them returned making a response rate of % 84.6. Among these, 20 were excluded from further analyses due to excessive missing data. Thirteen cases were also discarded because they did not meet the criteria of inclusion. Consequently, the analyses were performed with the remaining 407 participants that met the sampling criteria.

2.1.3. Measures

2.1.3.1. Work- Family Conflict

Participants' level of perceived work-family conflict was measured by the Turkish version of Netemeyer, Boles and McMurrian's (1996) Work-Family

Conflict and Family-Work Conflict Scale (See Appendix B1 for the scale). The scale involved 10 items with 5 items tapping each dimension. Respondents were required to give their answers on a 5 point Likert-type scale with values ranging from 1 (*completely disagree*) to 5 (*completely agree*). A sample item of the scale is “*Things I want to do at home do not get done because of the demands my job puts on me*”. The scale was adapted and translated into Turkish by Apaydın (2004). Apaydın (2004) reported that the measure has reliability values of .87 for W-to-FC dimension and .71 for F-to WC dimension.

2.1.3.2. Motivation Toward Work

The English version Work Extrinsic and Intrinsic Motivation Scale (WEIMS) by Tremblay, Blanchard, Taylor, Pelletier and Villeneuve (2009) was used to measure individuals’ motivation toward work. The scale consisted of 18 items measuring all of the motivational constructs proposed by SDT (Deci & Ryan, 1985). Since no Turkish version of the scale existed in the literature, scale items were translated to Turkish by the researcher. Then, two bilingual psychologists, who held master’s and doctorate degrees, respectively, independently back translated the scale items to the original English version. At the end of this process, a discussion was held among the translators to check for the discrepancies in translations. Eventually, the items were overviewed and finalized by the supervisor of the study. (See Appendix B2 for the scale items). Participants gave their responses to the Turkish version of WEIMS on a 5 point Likert-type scale with values ranging from 1 (*does not correspond at all*) to 5 (*corresponds exactly*). A sample item of the scale is “*I am presently involved in my work because this is the type of the work I choose to attain a certain lifestyle*” The scale was reported to be reliable with Cronbach’s Alpha values for the subscales ranging from .64 to .83 (Tremblay et al., 2009). Participants’ motivational profiles are determined by utilizing the Work Self-Determination Index (W-SDI; Vallerand, 1997) and by using the following formula proposed by Tremblay et al. (2009): $W-SDI = (+3 \times IM) + (+2 \times INTEG) + (+1 \times IDENT) + (-1 \times INTRO) + (-2 \times EXT) + (-3 \times AMO)$. The resulting score

represents one's relative self-determination level with positive scores indicating more autonomous (determined) motivation and negative scores indicating controlled (non-self determined) motivation

2.1.3.3. Job Characteristics

Individuals' perceptions of characteristics of their job were measured by the Turkish version of Hackman and Oldham's (1980) Job Diagnostic Survey (JDS). The scale was adapted to Turkish by Varoğlu (1986) and consists of 15 items that asks respondents to rate their job characteristics on a 5-point Likert type scale ranging from 1 (*very inaccurate*) to 5 (*very accurate*). A sample item of the scale is "My task is arranged so that I do not have the chance to do entire identifiable task from the beginning to end" (r). The motivating potential score (MPS) was computed via MPS index (Hackman & Oldham, 1975) according to the formula: $MPS = [(Skill\ variety + Task\ Identity + Task\ Significance)/3] \times [Autonomy] \times [Feedback]$.

Hackman and Oldham (1975) reported that the scale has reliable psychometric characteristics with Cronbach Alpha values ranging from .59 to .71 across dimensions (Refer to Appendix B3 to review the scale).

2.1.3.4. Work Support

Six items from Job Demands and Resources Scale (Xanthopoulou et al., 2007) that represented both colleague and supervisory support was administered to participants to measure social support at work. The scale items were translated to Turkish by Metin (2010) and found to have adequate reliabilities with Cronbach's Alpha estimates .75 for coworker support and .92 for supervisory support. Respondents were required to provide their answers on a 5- Point Likert -type scale with the response options ranging from 1 (*completely disagree*) to 5 (*completely agree*). A sample item that represented supervisor support is "My supervisor informs me whether he/she is satisfied with my work" (Refer to Appendix B4 for the scale).

2.1.3.5. Emotional Exhaustion at Work

Five items from Turkish version of emotional exhaustion dimension of Maslach Burnout Inventory (MBI; Maslach & Jackson, 1986), by Ergin (1992), was employed to measure participants' levels of work-related emotional exhaustion.

The scale has been reported to have sufficient reliability with Cronbach's Alpha value of .83 for emotional exhaustion dimension (Çapri, 2006). Ratings of the items were made on a 5 Point Likert-Type scale with anchors changing from 0 (*Never*) to 4 (*Always*). A sample item of the scale is "*I am emotionally drained from my work.*" (See Appendix B5 for the scale).

2.1.3.6. Job Satisfaction

Three items from the General Job Satisfaction Subscale of the Job Diagnostic Survey (JDS; Hackman & Oldham, 1975) and 1 item - Kunin's (1955) Faces Scale were utilized to evaluate participants' levels of job satisfaction (See Appendix B6 for the items). Responses were given on a seven point Likert-type Scale (1= *completely disagree*; 7= *completely agree*). The General Job Satisfaction Subscale of the JDS was adapted to Turkish by Bilgiç (2008) and reported to be a reliable measure with Cronbach's Alpha =.78 (Bilgiç, 2008). A sample item that reflected job satisfaction is "*I am generally satisfied with the kind of work I do in this job*".

2.1.3.7. Spousal Support

An eight-item Emotional Support Subscale of Spousal Support Scale (Yıldırım, 2004) was employed to assess participants' subjective evaluations of the support they received from their spouses (See Appendix B7 to review the scale). Although Yıldırım (2004) did not provide information about the Cronbach's α value of this subscale, he reported a high degree of internal consistency for the overall measure ($\alpha=.95$). The scale required participants to respond on a 5- Point Likert-

Type scale with the anchors ranging from 1 (*completely disagree*) to 5 (*completely agree*). A sample item of the scale is “*My spouse makes me feel that s/he is by my side*”.

2.1.3.8. Perceived Control at Home

The Powerlessness subscale of Alienation Test (Maddi, Kosoba, & Hoover, 1979) was used to measure the degree to which participants feelings of control. While the original scale assesses one’s perceptions of general control in life, Demokan (2009) translated the scale to Turkish and adapted it to home environment (Refer to Appendix B8 to see the scale items). The scale involved eight items and responses were given on a 5 point Likert-type scale (1= *Disagree*; 5= *Agree*). Since the items of the scale had negative connotations, these items were reversed to reflect participants’s perceptions of control over family-related events. Thus, lower scores on this measure represented higher levels of perceived control concerning family life. Demokan (2009) reported that the scale is a reliable measure having an internal consistency value of .77. A sample item of the scale is “*There is little I can do to change many of the important things in my home life*”.

2.1.3.9. Motivation Toward Family

Although there is one scale that measure individuals’ motivation toward family related activities on the basis of the assumptions of the SDT (Motivation Toward Family Activities Scale; Senecal & Vallerand, 1999), the scale was constructed in French and items were not available to the researcher. Therefore, a new measure was developed by reviewing the existing motivation scales that utilized the SDT, and by adapting them to the family context. Thirty six items that encompassed each six types of motivation regarding six different categories of family activities were generated. These six specific activity categories, which were developed by mainly relying on Senecal & Vallerand’s (1999) work, were as follows; a) activities regarding household tasks (housecare, house cleaning,

decoration and repairing etc.), b) activities regarding children's education (helping them doing school assignments, listening to their school-related problems and offer solutions, providing resources for their education and training etc.) c) activities regarding physical and psychological development of children d) leisure activities with children (going to the cinema, playing games with the children etc.), (e) activities that concern the physical and psychological care of the spouse, and f) leisure activities with the spouse (spending time with the spouse, going to a vacation etc). Each of these activity categories involved an item that represented amotivation, introjected motivation, external motivation, identified motivation, integrated motivation, and lastly, intrinsic motivation (Refer to Appendix B9 to see the items). Sample items developed are as the follows: "*I am involved with the household tasks such as housecare, house cleaning, decoration and repairing etc. because it is pleasant for me to carry out these tasks.*" (intrinsic motivation) and "*I am personally involved with the activities regarding my children's education because if I don't, I feel guilty.*" (introjected motivation).

Participants indicated their motivation levels on a 5-point Likert type scale with the response options 1; *completely inaccurate*, 5; *completely accurate*. Participants' motivational profiles were reflected via F-SDI, which was adapted from W-SDI (Vallerand, 1997) by using the same formula. Positive scores on the scale indicated autonomous (self-determined) motivation toward family related activities, whereas negative scores indicated controlled (non-self determined) motivation.

2.1.3.10. Family Satisfaction

Five items from Satisfaction with Life Scale (SWLS; Diener, Emmons, Larsen, & Griffin, 1985) which was adapted to marriage by Üzümcüoğlu (2013) were used to evaluate individuals' satisfaction with their family lives. Participants answered on a 7 point Likert –Type scale with anchors 1 (*completely disagree*) and 7 (*completely agree*). Sample item of the scale is "*In most ways my family life is close to my ideal*" (See Appendix B10 for the items). The reported Cronbach's Alpha value of the scale was .88 (Üzümcüoğlu, 2013).

2.1.3.11. Emotional Exhaustion at Home

In order to measure family-related emotional exhaustion, five items from Turkish version of emotional exhaustion dimension of Maslach Burnout Inventory (Ergin, 1992) was adapted to family context by the researcher by rewording the items. As an example, the MBI item “*I feel I’m working too hard on my job.*” was revised as “*I feel I’m working too hard in order to maintain the order in family life*”. (See Appendix B11 for the scale items). Responses were made on a 5 point Likert –Type scale with the options ranging from 0 (*Never*) to 4 (*Always*).

2.1.3.12. Life Satisfaction

Five items from the Satisfaction with Life Scale (SWLS; Diener, Emmons, Larsen, & Griffin, 1985) were used in the study to assess individuals’ satisfaction with their lives (Refer to Appendix B12 to see the scale items).The scale was translated to Turkish by Köker (1991) and the test-retest reliability of the scale was reported to be .85. As in the case of family and job satisfaction, the answers were given on 7 point Likert-type scale; 1 (*completely disagree*) and 7 (*completely agree*). Sample item of the scale is “*In most ways my life is close to my ideal.*”

2.1.3.13. Demographics and Control Variables

In order to analyze and control for their potential effects on the variables of interest, participants were asked to indicate their gender, age, educational level, occupational position, occupational tenure, duration of marriage, number of children they have, and the ages of their children. Respondents were also asked to report whether they had flexible work schedules and whether they received regular support for childcare and home-related activities. Items regarding demographical information are presented in Appendix B13.

2.2. Results

2.2.1. Work-Family Conflict

Explanatory factor analysis (EFA) by using varimax rotation technique was performed by using SPSS 16.0 in order to examine the factor structure of the Turkish version of WFC scale (Netemeyer, Boles and McMurian, 1996) by Apaydın (2004). As expected, factor analysis results revealed two factors explaining 67.11% of the total variance. Item distributions were the same with those suggested by Apaydın (2004); the first five items loaded on the first factor whereas the remaining five items had loadings on the second factor. Hence, these factors represented the dimensions of work-to-family conflict and family-to work conflict, respectively. Results of the factor analysis are provided in Appendix C1.

Reliability analyses revealed Cronbach's α values of .92 for W-to-FC dimension, .82 for F-to-WC dimension, and .86 for the whole scale.

2.2.2. Motivation Toward Work

Explanatory Factor Analysis by utilizing the direct oblimin rotation method was performed to investigate the underlying factor structure of the recently translated WEIMS, and to compare its factorial pattern with that of the original English version. Although, Tremblay et al. (2009) reported that the WEIMS had a six-factor structure with each factor representing a different type of motivation as proposed by SDT (Deci & Ryan, 1985, 2000), findings of current EFA suggested a three-factorial solution. When the item distributions were analyzed, it was seen that the all of the three introjected motivation items loaded on the first factor which represented intrinsic motivation. Therefore, these items were deleted and EFA was implemented again with the remaining fifteen items.

Results of EFA showed that all of the items belonging to integrated motivation and identified motivation loaded on the first factor along with the intrinsic motivation items. On the other hand, items of amotivation and external motivation subscale of the extrinsic motivation, loaded to the second and to the third

factor, respectively. Considering these results, the first factor was labelled as intrinsic motivation, the second factor was labelled as external motivation and the third factor was labelled as amotivation. These three factors accounted for 56 % of the variance. Results of factor analysis are given in Appendix C2.

Reliability analyses rendered acceptable Cronbach's α values: .75 for the 15-item total scale, .77 for intrinsic motivation, and .70 for external motivation. Although internal consistency of the amotivation factor was found to be low (.58), this result was consistent with the Blais, Lachance, Vallerand, Brière, and Riddle,'s (1993) finding which reported a value of .59 for amotivation scale.

To check for the quasi- simplex pattern among the motivation types and to see whether they would display the self-determination continuum, several correlation analyses were performed. Results revealed that although the relationships between intrinsic motivation and external motivation ($r = .25, p < .05$) and between intrinsic motivation and amotivation ($r = -.16, p < .05$) were significant, amotivation was found to be unrelated to external motivation ($r = -.02, p > .05$). Although these findings suggest some deviation from the quasi-simplex pattern, these results are consistent with some of the previous findings which found no correlation between between amotivation and external motivation (see for example, Tremblay et al., 2009).

2.2.3. Job Characteristics

Consistent with the literature, explanatory factor analysis for Job Diagnostic Survey (JDS; Hackman & Oldham, 1980) yielded a five factor solution with the first factor representing task identity dimension, the second factor representing the task significance dimension, the third factor representing the autonomy dimension, the fourth factor representing the skill variety dimension and the fifth representing the feedback dimension of the scale. Results rendered that these five factors accounted for 58% of the total variance. Results of the explanatory factor analysis are presented in Appendix C3.

Internal consistency of the JDS and its subdimensions were examined through a series of reliability analyses. Results rendered low Cronbach's α values for the subscales; .61 for task identity, .58 for task significance, .50 for autonomy, .55 for skill variety, and .42 for feedback. However, these values were similar to or even higher than those reported by the previous studies (e.g. Coşkun, 2012), and the Cronbach's α value of the total scale was .78 indicating the appropriateness of using the scale.

2.2.4. Work Support

EFA revealed two factors for the six-item scale that intended to measure social support at work). The two factors accounted for 78.99% of the total variance. As expected, the first three items loaded on the first factor which represented supervisory support and the remaining three items loaded on the second factor which represented coworker support. Findings of the EFA are shown in Appendix C4.

Cronbach's Alpha values were .90 and .80 for supervisory support and coworker support, respectively. Internal consistency reliability coefficient for the total six-item scale was .86.

2.2.5. Emotional Exhaustion at Work

For the emotional exhaustion sub- dimension of MBI, EFA results revealed one factor solution which explained 57.38% of the total variance. All of the items' loadings ranged from .60 to .84. Factor loadings of the items are shown in Appendix C5, along with the eigenvalue and explained variance.

The reliability coefficient of the scale was also satisfactory with the Cronbach's α value .81, and the item-total correlations of the all items were higher than the cut-off value .30.

2.2.6. Job Satisfaction

As expected, EFA results rendered one factor for four- item job satisfaction measure. This one factor accounted for the 73.77% of the total variance in the scale.

The loadings of the items were high, changing from .80 to .88. Results of EFA are presented in Appendix C6.

Reliability of the four-item job satisfaction scale was sufficient with Cronbach's Alpha of .88. Item-total correlations were also high, ranging from .66 to .80.

2.2.7. Spousal Support

EFA rendered one underlying factor accounting for 71.02% of the total variance for eight- item emotional support subscale of spousal support measure. Factor loadings of the items ranged from .72 to .92. Factor loadings, eigenvalues along with the explained variance are presented in Appendix C7.

Internal consistency of the measure was evaluated through reliability analysis and a high Cronbach's Alpha value (.94) was found for the scale. Item total correlations of the items changed between .88 and .65.

2.2.8. Perceived Control at Home

In congruence with the findings provided by Demokan (2009), EFA for the eight-item Powerlessness subscale of Alienation Test (Maddi, Kosoba, & Hoover, 1979) yielded one factor solution for the measure. This one factor explained 55.48% of the variance and all of the items' loading were above .50. Loadings of the items as well as eigenvalues and explained variance are provided in Appendix C8.

Internal consistency of the scale was also very high with a Cronbach's α estimate of .94. The item-total correlations of the items changed from .65 to .88.

2.2.9. Motivation Toward Family

In order to investigate the factor structure and the psychometric properties of newly developed 36-item Motivation toward Family Life Scale, EFA was run by utilizing the direct oblimin rotation option. After modifications, the results revealed a three factorial solution. The first factor represented intrinsic motivation whereas

the second and the third factors represented external motivation and amotivation. These findings implied that the factorial pattern underlying Motivation toward Family Scale was identical with that of the Work Extrinsic and Intrinsic Scale. Three factors accounted for 42.62% of the total variance. There were no cross-loaded items and the loadings were satisfactory with the lowest value being .41 and the highest being .87. EFA results for the 17 items are shown in Appendix C9.

When the reliability analyses were performed to check internal consistencies of the dimensions, it was found that all the sub-dimensions had adequate reliability estimates; $\alpha = .76$ for intrinsic motivation, $\alpha = .83$ for external motivation, and $\alpha = .79$ for amotivation.

The quasi-simplex pattern among the motivation types measured by the Motivation Toward Family Scale was also explored. Correlational analyses revealed that while a moderate, negative correlation existed between intrinsic family motivation and family amotivation ($r = -.37, p < .001$), there was a positive correlation amotivation and external motivation ($r = .18, p < .001$). On the other hand, the relationship between intrinsic motivation and external motivation was positive, weak and approached to non-significance level ($r = .10, p = .05$). Like in work motivation, these findings indicated that correlations did not follow the simplex pattern as proposed by SDT. Still, these results were consistent with the several findings in the literature which found small-to-moderate negative relationships between intrinsic motivation and amotivation (e.g., Levesque et al., 2007), positive relationships between external and amotivation (e.g., Pelletier, Fortier, Vallerand, Tuson, & Brière, 1995), and between intrinsic and external motivation (e.g., Gagne et al., 2010).

2.2.10. Emotional Exhaustion at Home

As expected, EFA extracted only one factor for the emotional exhaustion subdimension of MBI (Maslach & Johnson, 1986) which was adapted to family context by the researcher. This one underlying factor accounted for 58.12 % of the

variance and all of the item loadings were above .65. The results of EFA are presented in Appendix C10.

Internal consistency of the scale was also satisfactory (Cronbach's $\alpha = .81$) and item-total correlations of the items ranged from .52 to .68.

2.2.11. Family Satisfaction

Participants' levels of perceived satisfaction with their families were assessed with a five- item scale which was developed by Üzümcüoğlu (2013) by adopting the items to family life.

In line with the Üzümcüoğlu's (2013) findings, EFA resulted in one factor solution. This one factor explained 71.31 % variance and loadings of the items were all above .80. The results are provided in Appendix C11.

Reliability analysis rendered a high level of internal consistency for the scale with a reliability coefficient of .92, and all of the item-total correlations were above .75.

2.2.12. Life Satisfaction

Expectedly, explanatory factor analysis extracted one underlying factor for the five -item life satisfaction measure. Results showed that this one factor accounted for 76.07 % of the total variance and loadings of the items were, again, found to be very high; with the lowest value of .82 and the highest .90. Factor loadings, explained variance and the eigenvalue are presented in Appendix C12.

Internal consistency of the life satisfaction measure was also found to be very high with a Cronbach's α value of .92, and all of the item total correlations were above .77.

2.3. Discussion Concerning the Factor Analyses and Simplex Patterns of WEIMS and Motivation Toward Family Scale

The EFAs yielded the expected factorial patterns for all the study measures except for the WEIMS (Work Extrinsic and Intrinsic Motivation Scale) and Motivation Toward Family Scale. Disconfirming the studies of Blais et al., (1993), Tremblay et al.(2009), and Senecal and Vallerand (1999) which reported six-factorial solutions representing all the motivation types as defined by SDT, the results of the present study revealed three factors that reflected only amotivation, external motivation, and intrinsic motivation forms for both scales. Although, in the literature there are many cases that documented either five or four factors in which either intrinsic, integrated, or identified motivations merged together (Chen & Jang, 2010; Chirkov, Vansteenkiste, Tao, & Lynch, 2007; Fernet, Senécal, Guay, Marsh, & Dowson, 2008; Kusrkar, Croiset, Kruitwagen, & Cate, 2010; Vallerand et. al, 1992; Verloigne et al., 2011), it was surprising to find out introjected motivation did not emerged as a separate dimension. Since clustering the items of introjected motivation along with those of more autonomous motivation forms would violate the basic assumptions of SDT, these items were dropped from the scales.

The SDT measures utilized in Turkey that aimed to measure individuals' motivation in different life arenas such as sports/exercise (Türkmen, 2013) , health (Çenesiz, 2015), relationships (Kındap, 2011) and education (Böyüksolak, 2016; Ünal-Karagüven, 2012; Köseoğlu, 2013; Önder, Beşoluk, İskender, Masal, & Demirhan; 2014; Sungur & Senler, 2010) also revealed either six, five or four factorial solutions. Therefore, cultural context can not account for these study findings. It may be that the three-factorial solutions are specific to the domains in which participants' motivations were measured. Since work and family are major arenas in one' s life, even the most autonomously motivated individuals may feel a sense of pride when they successfully accomplish work/family related tasks and feel guilt (or shame) when they fall behind the performance standards. Rewording of the question stem "*The only* reason I am performing this activity..." in the scales may also help individuals to elaborate more deeply on the real causes of their behaviors

and allow them to differentiate the essential reasons for engaging in these activities. Future studies utilizing these scales may deepen our understanding of the dimensionality of work and family motivation.

As far as the quasi-simplex patterns are concerned, results showed some violations of the self-determination continuum. For the WEIMS, amotivation was found to be unrelated to external motivation. For the Motivation toward Family Scale, the relationship between external and intrinsic forms of motivation was positive and nearly insignificant. Although these violations of the quasi-simplex patterns most likely to result from the deviations from the expected factorial solutions, there are, however, many studies documenting similar violations (de Bilde, Vansteenkiste, & Lens, 2011; Cokley, 2000; Fernet et al., 2008; Gagne et al., 2010; Gagne et al., 2015; Halvari, Halvari, Bjørnebekk, & Deci, 2010; Mullan, Markland, & Ingledew, 1997; Niven & Markland, 2016; Pelletier et al., 1997; Tremblay et al., 2009). Overall, as put by Chemolli and Gagne (2014), these findings cast some doubts on the continuum structure of motivation types as proposed by SDT.

CHAPTER 3

MAIN STUDY- METHOD

Main study was conducted in order to determine whether the factor structures of the measures suggested by EFA analysis would be confirmed in a different sample, and to test for the hypothesized relationships among the variables of interest. Hence, the method, the information concerning the scales used in the main study, their psychometric properties, and the results of the analyses regarding the proposed model are provided under the headings 1) Method 2) Results.

3.1. Method

3.1.1. Sample

The sample of the main study involved 405 married working women and men who had at least one child with a maximum age of 17 years old. Thus, the criteria of inclusion were the same as the pilot study. Among those who participated in the study, 232 (57.3%) were female and 173 (42.7%) were male.

Participants' ages ranged from 22 to 68 with *Mean* = 39.50 and *S.D.* = 6.89. Majority of the participants (231, 57%) held bachelor's degree, 54 (13.3%) of them had high school degree, 54 (13.3 %) had a graduate (either master's or Ph.D.) degree, 53 (13.1%) had a two-year college degree, and 13 (3.2 %) of them had an elementary school degree.

The average tenure of the participants was approximately 14 years; (minimum: one month- maximum: 45 years; *S.D.* = 8.34). While 184 (45.4%) of the participants reported that they had no flexible working hours, 96 (23.7%) of them reported that they were flextime workers. On the other hand, 124 (30.6%) participants indicated that they worked with a partially flexible schedule. There was one person (0.3%) who did not provide information about his/her working hours.

Most of the participants (199, 49.1%) had two children, 167 (41.2%) had one child. There were 34 (8.4%) individuals with three children and 5 (1.2%) individuals with four children. Participants' youngest children's ages ranged from 0 to 17.

In terms of the received support concerning household tasks and childcare, 216 individuals (53.3%) indicated receiving extra support for household tasks and 183 individuals (45.2%) reported receiving support for childcare.

3.1.2. Procedure

The main study also adopted the snowball technique as being a convenient sampling strategy. Questionnaire packages, as well as debriefing forms and informed consents were delivered to psychology students in a private university in self-stamped envelopes. Students were requested to pass the surveys to individuals who met the sampling criteria. Each student received maximum three questionnaires and earned one bonus point for delivering these surveys. The process of data collection followed the ethical guidelines; participants were notified about not to write their names on the questionnaires, and were ensured about anonymity and confidentiality of their responses.

Five hundred and sixty questionnaires were delivered and 428 of them returned with a response rate of 76%. Among these, fourteen were excluded from further analyses due to excessive missing data. Nine cases were also discarded because they did not meet the criteria of inclusion. Hence, the analyses were performed on the remaining 405 cases.

3.1.3. Measures

Since pilot study results revealed that scales had adequate psychometric properties, the same measures utilized in the main study. Moreover, in order to explore the moderating influences of work and family role identification on cross-domain effects of WFC, additional instruments measuring these constructs were employed. Below, information regarding the scales added for the main study is presented. All the factorial structures extracted by the EFA analyses in the pilot

study were confirmed by confirmatory factor analyses. Results of the confirmatory analyses are given in Appendices D1-D14. Since both EFA and CFA revealed three factorial solutions for Work Extrinsic Intrinsic Motivation Scale and Motivation toward Family Scale, information regarding the computation of self-determination indices are also provided below, under relevant headings. Additional information concerning the number of scale items and internal consistency reliabilities of the scales used in the main study are presented in Table 1., along with the means, standard deviations and bivariate correlations among the study variables.

3.1.3.1. Identification with Work Role

Participants' identification with their work roles was measured by using Work Role Work Involvement Scale (Kanungo, 1982). The scale has 6 items, and participants gave their responses 5 point Likert Type scale (1= Strongly disagree; 5= Strongly agree). The scale was adapted to Turkish by Aycan and Balcı (2001), and used by Bıçaksız (2009). A sample item of the scale is "*Most of the important things in my life involve my job*" (See Appendix B14 for the scale items). Bıçaksız (2009) provided a Cronbach's α value of .64 for the scale.

3.1.3.2. Identification With Family Role

The revised version of Work Role Work Involvement Scale (Kanungo, 1982) which was adapted to family role by Bıçaksız (2009) by changing the terms "work" to "family" was used to measure levels of family role identification. Responses to the six-item measure were made on a 5 point Likert Type scale (1= Strongly disagree; 5= Strongly agree). A sample revised item of the scale is "*Most of the important things in my life involve my family*" (See Appendix B15 for the scale items). Bıçaksız (2009) provided a Cronbach's α value of .74 for the scale.

3.1.3.3. Motivation Toward Work

Since in both EFA and CFA (See Appendix D2 for CFA findings) three motivation types rather than six emerged, the original W-SDI formula; $W-SDI = (+3 \times IM) + (+2 \times INTEG) + (+1 \times IDEN) + (-1 \times INTRO) + (-2 \times EXT) + (-3 \times AMO)$, (Vallerand, 1997) could not be applied in the present study. Therefore, the variable of W-SDI was computed by using the following revised formula; $W-SDI = (+3 \times IM) + (-1 \times EXT) + (-2 \times AMO)$. As mentioned before, the resulting score reflected an individual's motivational profile toward work; with positive scores signifying autonomous (self-determined) motivation and negative scores signifying controlled (non-self determined) motivation.

3.1.3.4. Motivation Toward Family

As in the case of work motivation, since factor analyses (see D10 for CFA results) revealed three motivation types, only the variables that reflected participants' levels of amotivation, external motivation and intrinsic motivation were created.

Therefore, participants' motivation levels toward family life was determined by Family Self Determination Index (F-SDI), by adapting and revising the W-SDI formula (Vallerand et al., 1997) according to the equation; $F-SDI = (+3 \times IM) + (-1 \times EXT) + (-2 \times AMO)$. The resulting score derived from the F-SDI index reflected an individual's motivation toward family related activities; with positive scores signifying autonomous (self-determined) motivation and negative scores signifying controlled (non-self determined) motivation.

CHAPTER 4

MAIN STUDY- RESULTS

The present study intended to explore the relationships between work-family conflict and self-determined motivation along with the commonly studied antecedents (job characteristics, work support, spousal support, perceived control at home) and outcomes (job satisfaction, job-related emotional exhaustion, family satisfaction, family- related emotional exhaustion, life satisfaction) by proposing a comprehensive causal model.

In this chapter, findings from the main study are presented in four sections: 1) descriptive statistics and bivariate correlations among the study variables, 2) testing of the proposed model and hypotheses via path analysis, 3) analyses concerning the hypothesized combined effects of domain-specific motivation on W-to-FC and F-to-WC, and 4) regression analyses regarding the moderating roles of work/family identification in the relationships between work-family conflict dimensions and satisfaction outcomes.

4.1. Descriptive Statistics and Bivariate Correlations

Prior to hypothesis testing, means, standard deviations of the study variables, and the correlations among them were calculated. Information concerning these descriptive findings and the Pearson's correlation coefficients are provided in Table 1.

4.1.1. Bivariate Correlations Among the Variables

As seen in Table 1., the correlations among the variables of interest revealed the expected patterns offering preliminary support for the proposed hypotheses and the study model.

Since participants' gender seemed to affect several variables of the study, including W-to-FC, motivation toward family, perceived job characteristics, work-

role identification, job satisfaction, work-related exhaustion, family-related exhaustion, several independent sample t-tests were performed to investigate these effects of gender. Results revealed that women participants were more likely to experience W-FC than male participants; $t(403) = 2.09$, $M. D. = .25$, $p < .05$ and display more autonomous forms of motivation toward family; $t(403) = 2.29$, $M. D. = .72$, $p < .05$. On the other hand, male participants were more likely to perceive their jobs as motivating; $t(403) = -3.22$, $M. D. = -9.20$, $p < .005$, more likely to identify with their work-roles; $t(403) = -2.37$, $M. D. = -.20$, $p < .05$, and more likely to be satisfied with their jobs; $t(403) = -2.16$, $M. D. = -.29$, $p < .05$, than women. They were also less likely to report both forms of emotional exhaustion: $t(403) = 2.39$, $M. D. = .20$, $p < .05$, for work-related exhaustion; $t(403) = 4.82$, $M. D. = .39$, $p < .001$, for home-related exhaustion.

Consistent with the literature (e.g., Kossek & Ozeki, 1998; Mesmer-Magnus & Viswesvaran, 2005; Üzümcüoğlu, 2013) a positive moderate relationship was found between W-to-FC and F-to-WC ($r = .35$, $p < .01$) suggesting that they are related but different constructs. Relying on the literature, participants' mean scores on these two dimensions of WFC were also compared. Results of the paired samples t-test analysis revealed that the mean scores on W-to-FC were higher than the mean scores on F-to-WC: $t(404) = 10.69$, $p < .001$, $MW\text{-to-FC}(405) = 2.87$, $MF\text{-to-WC}(405) = 2.22$, $M. D. = .65$. These findings confirmed the asymmetrical permeability of WFC; that is W-to-FC is more commonly experienced than F-to-WC.

4.2. Hypotheses Testing

4.2.1. Testing of the Proposed Model via Path Analysis

In order to test the hypothesized relationships illustrated in Figure 2a. and cross-domain effects of WFC dimensions depicted in Figure 2b., as well as to see whether the proposed conceptual model would fit the data, several path analysis were performed by using EQS 6.1. (Bentler & Wu, 2005).

Table 1 Number of Scale Items, Internal Consistencies, Bivariate Correlations, Means and Standard Deviations of the Study Variables

Variables	# of Items	1	2	3	4	5	6	7	8	9	10	11	12	13	14
1. Age	-	-													
2. Gender	-	.21**	-												
3. Education	-	.00	.09	-											
4. Tenure	-	.74**	.15**	.06	-										
5. Flexible hours	-	-.03	.22**	-.10*	-.15**	-									
6. Marital year	-	.79**	-.04	-.17**	.64**	-.05	-								
7. N. of children	-	.40**	-.02	-.10*	.35**	-.07	.54**	-							
8. Y. child age	-	.64**	-.03	-.19**	.45**	-.05	.77**	.14**	-						
9. Childcare S.	-	-.37**	-.11*	.12*	-.31**	.02	.46**	-.11*	-.51**	-					
10. Home support	-	.06	-.05	.29**	.04	.02	-.05	-.06	-.06	.24**	-				
11. WFC	10	-.02	-.04	-.05	.03	-.08	.03	.06	.00	.10	.07	.85			
12. W-to-FC	5	-.02	-.10*	-.09	.07	.20**	.07	.08	.04	.06	.04	.87**	.90		
13. F-to-WC	5	-.01	.06	.03	-.03	.10*	-.05	.00	-.04	.10*	.08	.76**	.34**	.79	
14. W-SDI	12	-.00	.06	.11*	-.03	.18**	-.04	-.04	-.01	-.02	.06	-.21**	-.23**	-.09	.77
15. F-SDI	15	.02	-.11*	.02	.04	.00	-.01	-.09	-.06	.01	-.00	-.25**	-.15**	-.28**	.17**
16. MPS	13	.05	.16**	.11*	.07	.27**	-.00	.01	-.06	-.01	.18**	-.01	-.00	-.01	.43**
17. Supevisor supp.	3	.09	.08	-.11*	.04	.15**	.06	-.02	.01	-.00	.02	-.14**	-.14**	-.07	.32**
18. Coworker supp.	3	.03	.02	.03	.09	.04	-.02	-.00	-.02	.02	.08	-.14**	-.14**	-.08	.21**
19. Work support	6	.08	.06	-.06	.07	.13	.03	-.01	-.00	.00	.06	-.16**	-.17**	-.09	.33**
20. Spousal support	8	.00	.01	.04	.07	.03	-.04	-.08	-.02	-.03	.10	-.17**	-.11*	-.18**	.17**
21. Control at home	8	-.03	.04	.06	.02	.04	-.05	-.09	-.08	-.08	.07	-.44**	-.32**	-.41	.28**
22. Work R. Ident.	5	.14*	.12*	-.03	.12*	.08	.11*	.09	.13**	-.06	-.11*	.16**	.14**	.11*	.14**
23. Family R. Ident.	5	-.00	.03	-.07	.02	.03	.00	.04	-.02	-.03	-.08	-.09	-.04	-.13*	.06
24. Job Satisfaction	4	.13*	.11*	-.02	.10*	.20*	.12*	.10*	.08	-.10*	.01	-.20**	-.18**	-.15**	.63**
25. Exhaust. (Work)	5	-.05	.12*	-.02	.04	.24**	.04	-.02	-.03	.04	-.00	.48**	.51**	.24**	-.48**
26. Family Sat.	5	.03	.02	.04	.07	.08	.02	-.03	-.02	-.02	.04	-.24**	-.19**	-.21**	.29**
27. Exhaust. (Home)	5	-.07	-.23**	-.06	-.09	-.09	.04	.06	.02	.04	-.07	.43**	.38**	.33**	-.20**
28. Life Satisfaction	5	.04	-.07	.05	.09	.08	.03	.02	.01	-.05	.11*	-.24**	-.22**	-.16**	.39**
Mean		39.50	-	-	13.80	-	13.36	1.70	7.31	-	-	2.55	2.87	2.22	.99
Standard Deviation		6.89	-	-	8.34	-	6.80	.67	4.94	-	-	.86	1.18	.92	3.61

Table 1Continued

Variables	# of Items	15	16	17	18	19	20	21	22	23	24	25	26	27	28
14. W-SDI	12														
15. F-SDI	15	.78													
16. MPS	13	.18**	.80												
17. Supervisor supp.	3	.16**	.26**	.89											
18. Coworker supp.	3	.19**	.16**	.34**	.77										
19. Work support	6	.21**	.27**	.87**	.77**	.81									
20. Spousal support	8	.41**	.15**	.10	.16**	.14**	.94								
21. Control at home	8	.46**	.18**	.18**	.15**	.20**	.54**	.89							
22. Work R Ident.	5	-.21**	.13**	.10	-.08	.02	-.02	-.13**	.65						
23. Family R. Ident.	5	.22**	.09	.06	.09	.09	.16**	.04	.14**	.74					
24. Job Satisfaction	4	.18**	.47**	.41**	.31**	.45**	.14**	.22**	.19**	.14**	.88				
25. Exhaust. (Work)	5	-.13**	-.24**	-.34**	-.28**	-.38**	-.13**	-.28**	-.00	-.06	-.57**	.83			
26. Family Sat.	5	.44**	.21**	.18*	.19**	.23**	.64**	.53**	.00	.27**	.26**	-.19**	.91		
27. Exhaust. (Home)	5	-.43**	-.13**	-.12*	-.10*	-.14**	.57**	-.61**	.09	-.18**	-.19**	.34**	-.58**	.82	
28. Life Satisfaction	5	.32**	.22**	.18**	.20**	.23**	.49**	.45**	-.00	.19**	.37**	-.26**	.66**	-.46**	.92
Mean		7.76	58.35	3.68	4.19	3.94	4.16	4.08	2.78	4.08	5.04	1.55	5.76	1.07	4.84
Standard Deviation		3.12	28.74	1.01	.78	.74	.87	.91	.83	.72	1.35	.86	1.16	.82	1.33

72

Note. WFC= Work Family Conflict; W-to-FC= Work to Family Conflict; F-to-WC= Family to Work Conflict; W-SDI= Self-determined Motivation Toward Work; F-SDI= Self-Determined Motivation Toward Family; MPS= Job Motivating Potential; Work R. Ident.= Work Role Identification, Family R. Ident.= Family Role Identification, Exhaust. (Work) = Exhaustion at Work, Family Sat. = Family Satisfaction, Exhaust. (Home) = Exhaustion at Home. Gender: 0 = Female, 1= Male; Education Level 1= Elementary School, 2= High School, 3= Bachelor’s Degree, 4= Master’s Degree or Higher; Dichotomous Variables (Receiving Extra Support for Childcare, Receiving Extra Support for House care) 0= No, 1= Yes; Dichotomous Variable (Flexible Work Hours) 1= No, 2= Partially 3= Yes; Continuous Variables (Job Characteristics, Work Role Identification, Work Family Conflict, Perceived control at Home, Work Role Identification) measured on 5-point Likert Scale 1= Disagree, 5 = Agree; Continuous Variables (Job Characteristics, Motivation Toward Work, Spousal Support, Motivation Toward Family) measured on 5-point Likert Scale 1= Not Accurate , 5= Accurate; Continuous Variables (Emotional Exhaustion at Work, Emotional Exhaustion at Home) measured on 5-point Frequency Scale 0 = Never, 4= Always; Continuous Variables (Job Satisfaction, Marital Satisfaction, Life Satisfaction) measured on 7-point Likert Scale 1= Completely Disagree, 7= Completely Agree; Continuous Variable (Work Support) measured on 5-point Frequency Scale 1=Never, 5= Always. * $p < .05$, ** $p < .01$.

Prior to the analyses, error covariances were added between the outcome variables job satisfaction and job exhaustion, and family satisfaction and family-related exhaustion because of the theoretical links among these constructs. The errors between WFC dimensions (W-to-FC and F-to-WC) were also allowed to correlate, for the same reason. During model testing, the insignificant paths were omitted from the model in a stepwise fashion. In each analysis, L-M Test results were examined and if modification indices suggested the inclusion of any of these omitted paths, implying that this path might become significant, it was added to the model again. These modifications were performed until the model involved only significant paths.

When the path analysis was run, it was seen that the goodness of fit indices were below the satisfactory levels ($\chi^2(47, 405) = 334.36, p < .001, CFI = .86, NFI = .84, RMSEA = .12$), implying some inconsistencies between the model and the data. Results revealed that, contrary to predictions, W-to-FC did not predict job satisfaction ($\beta = -.06, p > .05$). Moreover, it was seen that paths between F-to-WC and family satisfaction ($\beta = -.01, p > .05$), and between F-to-WC and emotional exhaustion ($\beta = .06, p > .05$) were not significant either.

The results were also non-significant for the expected cross-domain effects of work-family conflict dimensions. Thus, there were no associations between W-to-FC and family satisfaction ($\beta = -.00, p > .05$), and between F-to-WC and job satisfaction ($\beta = -.05, p > .05$).

Although results revealed a non-significant cross-domain effect of W-to-FC on family satisfaction, L-M Test findings suggested inclusion of a path from W-to-FC to the variable of family exhaustion, implying a spillover impact exists for W-to-FC. Modification indices also recommended addition of a path that directly flows from perceived control at home to F-to-WC, indicating that the relationship between these variables is only partially mediated by family self-determined motivation. Lastly, it was observed that adding parameters that leading from work self-determined motivation to job satisfaction and family self-determined motivation to family satisfaction would improve the model. Based on these findings, the hypothesized model was revised. The respecified model is shown in Figure 3.

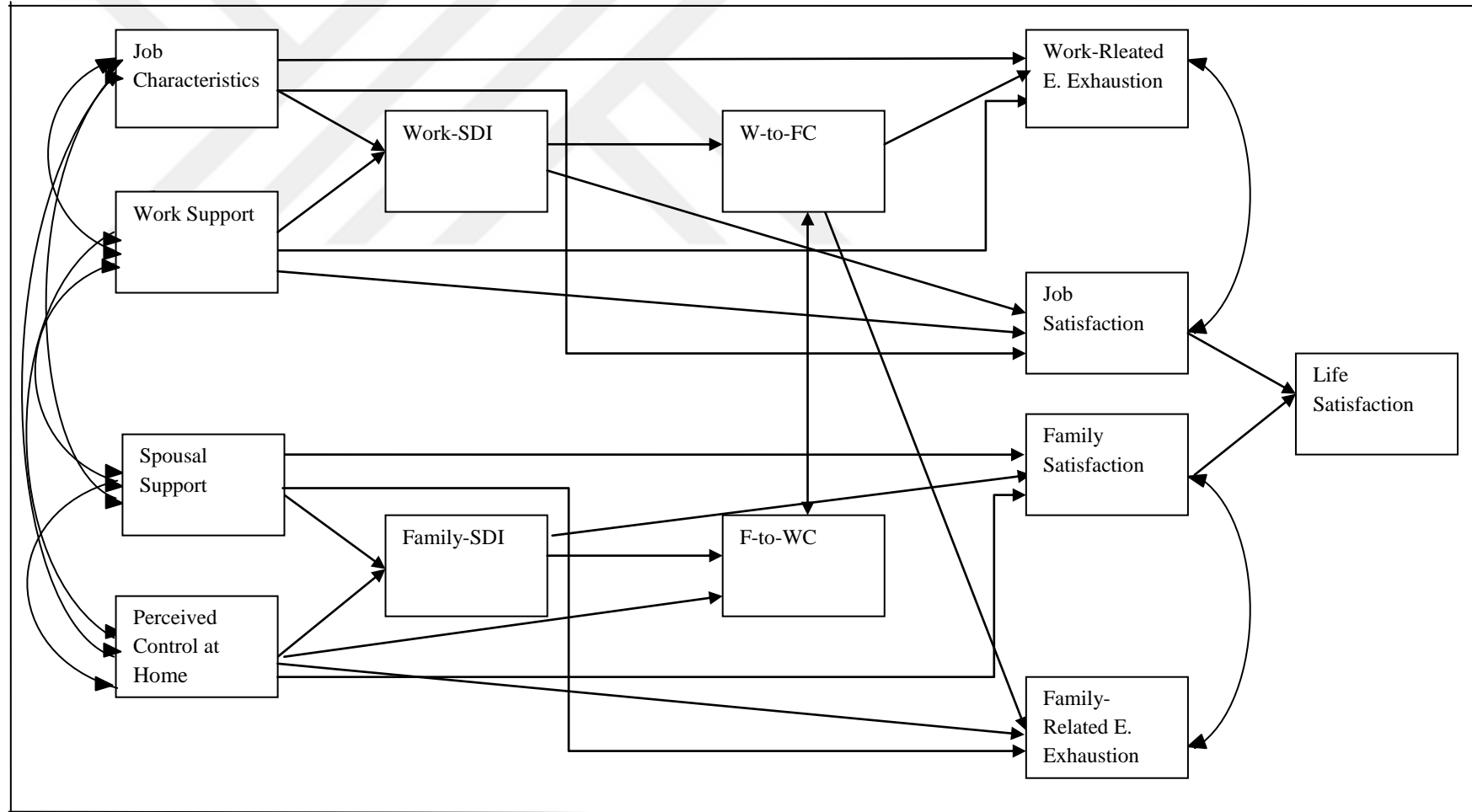

Figure 3 The Modified Model of Work-Family Conflict

When the analysis was performed, it was seen that modification of the model greatly enhanced the goodness-of fit indices showing that the model adequately fitted to data; $\chi^2(48, 405) = 200.27, p < .001, (\chi^2 / d. f. \text{ ratio} = 4.17), CFI = .92, GFI = .93, NFI = .90, SRMR = .09, RMSEA = .09, 90\% \text{ C.I.} = .08, .10.$

In *Hypothesis 1a*, it was stated that self-determined motivation toward work would be negatively related to W-to-FC. In line with this hypothesis, results revealed that self-determined toward work negatively predicted W-to-FC ($\beta = -.24, p \leq .05$). This finding suggested that individuals who displayed autonomous motivation toward work were less likely to perceive their work as interfering with their family. Hence, *Hypothesis 1a* was supported.

Hypothesis 1b maintained that self-determined motivation toward family would be negatively related to F-to-WC. When the findings were examined, it was seen that self-determined motivation toward family negatively predicted F-to-WC ($\beta = -.12, p \leq .05$). That is, as predicted, individuals who had autonomous motivation toward their families were less likely to perceive their family as interfering with their work. Thus, *Hypothesis 1b* was also supported. Moreover, in congruence with the previous L-M test statistics results, it was seen that perceived control at home had a significant direct effect on F-to-WC ($\beta = -.31, p \leq .05$) suggesting that individuals who perceived themselves as having control regarding family-related issues were less likely suffer from F-to-WC.

Overall, perceived control within the family domain and family self-determined motivation explained 14% of the variance in F-to-WC. Nevertheless, work self-determined motivation explained only 6% of the variance in W-to-FC, signifying that self-determined motivation toward work is not a very strong predictor of W-to-FC.

Hypotheses 3a and *3b* were concerned with the antecedents of self-determined motivation in work contexts. *Hypothesis 3a* predicted that job's motivating potential score would be positively related to self-determined motivation toward work whereas *Hypothesis 3b* stated that work support would be positively associated with work-self determined motivation. Findings yielded that both job

characteristics and work support positively predicted self-determined motivation toward work ($\beta = .37, p \leq .05$; $\beta = .23, p \leq .05$, respectively). These results revealed that individuals who rated their jobs' characteristics higher, and those who perceived their work environment as supportive, displayed more autonomous forms of motivation toward their work. Hence, *Hypotheses 3a* and *3b* were confirmed. In terms of the explained variances, it was observed that job characteristics and work support together accounted for 24% of the total variance in work self-determined motivation.

Hypotheses 4a and *4b*, on the other hand, were concerned with the antecedents of self-determined motivation in family contexts. According to *Hypothesis 4a*, perceived spousal support should have a positive impact on family-self-determined motivation. An examination of parameter estimates indicated that, as expected, spousal support positively predicted self-determination toward family ($\beta = .22, p \leq .05$). *Hypothesis 4b* predicted that individuals' perceptions of control in the family domain would have a positive direct effect on the level of family self-determined motivation. Not surprisingly, results of path analysis showed that perceived control at home was significantly associated with self-determined toward family ($\beta = .34, p \leq .05$). These results suggested that individuals who felt control in their family lives and those who received support from their spouses tended to display self-determined motivation toward their families. Both perceived control at home and spousal support accounted for 25% of the total variance in family self-determined motivation.

As previously mentioned, the relationship between W-to-FC and job satisfaction was shown to be insignificant. Therefore, *Hypothesis 5a* was not confirmed by the data. On the other hand, *Hypothesis 5b* which asserted a positive relationship between W-to-FC and emotional exhaustion at work, was supported. That is, W-to-FC significantly and positively predicted emotional exhaustion at work ($\beta = .45, p \leq .05$). Furthermore, in line with the results of L-M Test, the newly added path from W-to-FC to emotional exhaustion at family was also significant ($\beta = .22, p$

$\leq .05$). These findings implied that individuals who experienced high levels of W-to-FC tended to experience higher levels of exhaustion in both work and family contexts.

Since the proposed relationships between F-to-WC and family-related outcomes were also proven to be non-significant, *Hypothesis 6a*, which maintained that F-to-WC would negatively associated with family satisfaction, and *Hypothesis 6b*, which claimed that F-to-WC would be positively associated emotional exhaustion, were not supported.

As far as the cross-domain effects of WFC dimensions were concerned, path analyses results also revealed that there were no associations between W-to-FC and family satisfaction, and between F-to-WC and job satisfaction. Thus, *Hypothesis 7*, which suggested a negative, but weak relationship between W-to-FC and family satisfaction, and *Hypothesis 8*, which suggested a negative, but weak relationship between F-to-WC and job satisfaction were rejected.

Hypothesis 9 asserted that *a*) job satisfaction and *b*) family satisfaction would be positively associated with the ultimate outcome of life satisfaction. The results of the path analysis were, again, as predicted. That is, both job satisfaction ($\beta = .22$, $p \leq .05$) and family satisfaction ($\beta = .61$, $p \leq .05$) positively contributed to experience of life satisfaction though the effect of family satisfaction on life satisfaction was much stronger than that of job satisfaction. Therefore, *Hypothesis 9* was supported. These findings suggested that individuals who were satisfied with their jobs and those who were satisfied with their family reported higher levels of life satisfaction. The whole model accounted for 45% variance in life satisfaction.

As one can remember, *Hypotheses 10-13* concerned the direct relationships between the antecedents of self-determined motivation and outcomes of work-family-conflict.

For the work domain, *Hypothesis 10* expected *a*) a direct, positive relationship between perceived characteristics of the job and job satisfaction, and *b*) a direct, negative relationship between perceived characteristics of the job and work-related emotional exhaustion. Results provided support for the proposed direct

effects. That is, job characteristics positively predicted job satisfaction ($\beta = .25, p \leq .05$) and negatively predicted exhaustion at work ($\beta = -.17, p \leq .05$). Thus, individuals who perceived their jobs as highly motivating were more likely to be satisfied with their jobs and less likely to experience emotional exhaustion at work. The findings revealed that *Hypothesis 10* was confirmed.

Hypothesis 11, on the other hand, suggested *a*) a direct positive relationship between perceived work support and job satisfaction, and *b*) a direct, negative relationship between perceived work support and work-related emotional exhaustion. When the results of the path analysis were examined, it was seen that work support positively predicted job satisfaction ($\beta = .27, p \leq .05$), and negatively predicted exhaustion at work ($\beta = -.26, p \leq .05$). That is, individuals who received higher support from their colleagues experienced higher levels of job satisfaction and lower levels of emotional exhaustion. Based on these findings, it can be concluded that *Hypothesis 11* was also confirmed. Results also revealed that the newly added path flowing from work-self determined motivation to job satisfaction also was found to be significant ($\beta = .37, p \leq .05$), indicating that higher levels of autonomous motivation toward work predicted higher levels of job satisfaction.

Overall, self-determined motivation toward work, job characteristics and work support accounted for 46% of the total variance in job satisfaction. On the other hand, W-to-FC, job characteristics and work support explained 36% variance in job exhaustion.

As far as the family domain was concerned, *Hypothesis 12* suggested the existence of *a*) a direct, positive relationship between spousal support and family satisfaction, and *b*) a direct, negative relationship between spousal support and family-related emotional exhaustion. Findings of the path analysis were again, as expected. Spousal support predicted both family satisfaction ($\beta = .46, p \leq .05$) and exhaustion at home ($\beta = -.36, p \leq .05$). These results showed that individuals who received support from their partners experienced greater family satisfaction and lower levels of emotional exhaustion at home. Therefore, *Hypothesis 12* was also supported.

As in *Hypothesis 12, a)* a positive relationship between perceived control at home and family satisfaction, and *b)* a negative relationship between perceived control at home and family-related emotional exhaustion were expected in *Hypothesis 13*. Results showed that perceived control at home had unique effects on family satisfaction ($\beta = .22, p \leq .05$) and on emotional exhaustion at home ($\beta = -.36, p \leq .05$), confirming *Hypothesis 13*. Thus, individuals who felt themselves as having control regarding family issues expressed higher levels of family satisfaction and lower levels of family-related emotional exhaustion. As in the case of work-self determined motivation, the newly included path that flew from family-determined motivation to family satisfaction was also significant ($\beta = .14, p \leq .05$), meaning that higher levels of autonomous motivation toward family predicted higher levels of family satisfaction. As a whole, family-self determined motivation, spousal support and perceived control at home explained 47% variance in the family satisfaction, whereas W-to-FC, spousal support and perceived control accounted for the 46% variance in the variable of family related exhaustion. The results of the path analysis of the revised model are shown, again separately, in *Figure 4*. for the work domain, and in *Figure 5*. for the family domain.

In order to examine the mediations involved in the revised model, following the directions of Preacher and Hayes (2005), indirect effects were calculated by using EQS 6.1. (Bentler & Wu, 2005). It was seen that all the mediations involved in the model were significant. As predicted, work self-determined motivation mediated the influence of job characteristics on W-to-FC (*indirect effect* = $-.08, z \text{ value} = -4.32, S.E. = .00, p \leq .05$). Similarly, results revealed a mediating effect of work self-determined motivation on the relationship between work support and W-to-FC (*indirect effect* = $-.06, z \text{ value} = -3.63, S.E. = .02, p \leq .05$). Work self-determined motivation also partially mediated the relationships between work support and job satisfaction (*indirect effect* = $.09, z \text{ value} = 4.57, S.E. = .03, p \leq .05$) and between job characteristics and job satisfaction (*indirect effect* = $.14, z \text{ value} = 6.23, S.E. = .00, p \leq .05$). A mediating effect was also found for W-to-FC. Results yielded that work self-determined motivation affected job exhaustion via W-to-FC (*indirect effect* = -

.11, z value = -4.67, $S.E.$ = .00, $p \leq .05$). Thus, more autonomous forms of work motivation resulted in lower levels of W-to-FC, and in turn, decreased job exhaustion. Results also revealed that W-to-FC mediated the relationship between self-determined motivation toward work and family related emotional exhaustion (*indirect effect* = -.05, z value = -3.94, $S.E.$ = .00, $p \leq .05$); showing that higher levels of motivation toward work, resulted in lower levels of W-to-FC, and in turn, led to lower levels of emotional exhaustion at home. Moreover, it was seen that both job characteristics and work support influenced job exhaustion through their effects on work-self-determined motivation and W-to-FC (*indirect effect* = -.04, z value = -4.63, $S.E.$ = .00, $p \leq .05$; *indirect effect* = -.02, z value = -3.47, $S.E.$ = .01, $p \leq .05$, respectively). Significant indirect effects of job's MPS score and work support on family-related emotional exhaustion were also observed. That is, higher levels of job motivating characteristics led to increased self-determined motivation toward work, which, in turn, resulted in decreased W-to-FC, and decreased levels of W-to-FC eventually led to reduced emotional exhaustion at home (*indirect effect* = -.02, z value = -3.56, $S.E.$ = .00, $p \leq .05$). Likewise high levels of work support resulted in increased self-determination toward work, which in turn, resulted in decreased W-to-FC, and decreased levels of W-to-FC, in turn, predicted lower levels of emotional exhaustion at home (*indirect effect* = -.01, z value = -3.14, $S.E.$ = .00, $p \leq .05$).

Concerning the family domain, it was seen that self-determined motivation toward family mediated the relationship between spousal support and F-to-WC (*indirect effect* = -.03, z value = -2.05, $S.E.$ = .01, $p \leq .05$). On the other, the family self-determined motivation partially mediated the relationship between perceived control at home and F-to-WC (*indirect effect* = -.04, z value = -2.21, $S.E.$ = .02, $p \leq .05$). Family self-determined motivation also partially mediated the relationships between spousal support and family satisfaction (*indirect effect* = .03, z value = 2.65, $S.E.$ = .02, $p \leq .05$), and between perceptions of control and family satisfaction (*indirect effect* = .05, z value = 3.02, $S.E.$ = .02, $p \leq .05$).

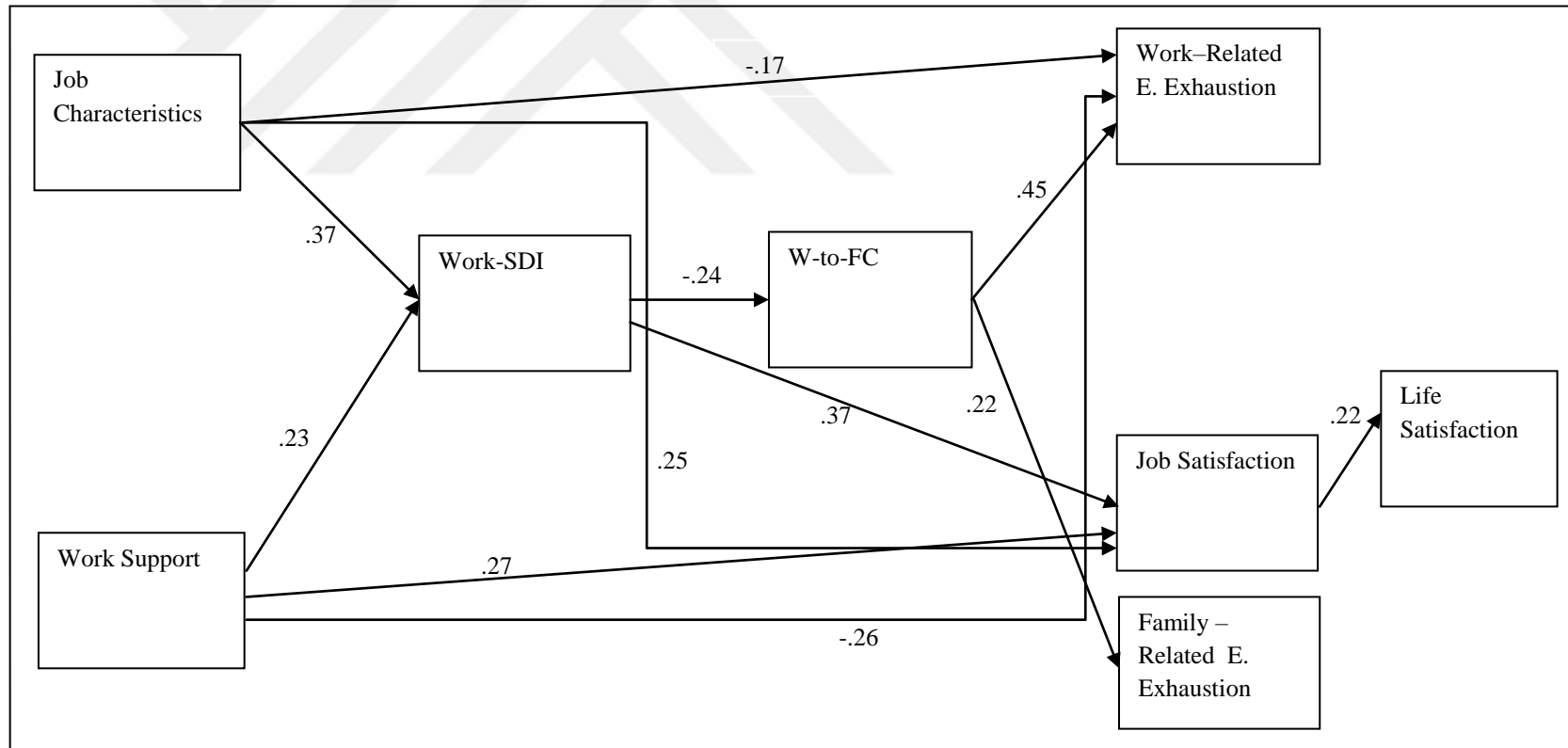

Note. All the estimates are standardized parameter estimates significant at $p \leq .05$. For simplicity, disturbances, inter-correlations between the independent variables (i.e., job characteristics and work support), correlated errors within the mediator variables (i.e., W-to-FC and F-to-WC) and within the outcome variables (i.e., job satisfaction and job exhaustion) are not included.

Figure 4 Path Analysis Results of the Modified Model for the Work Domain

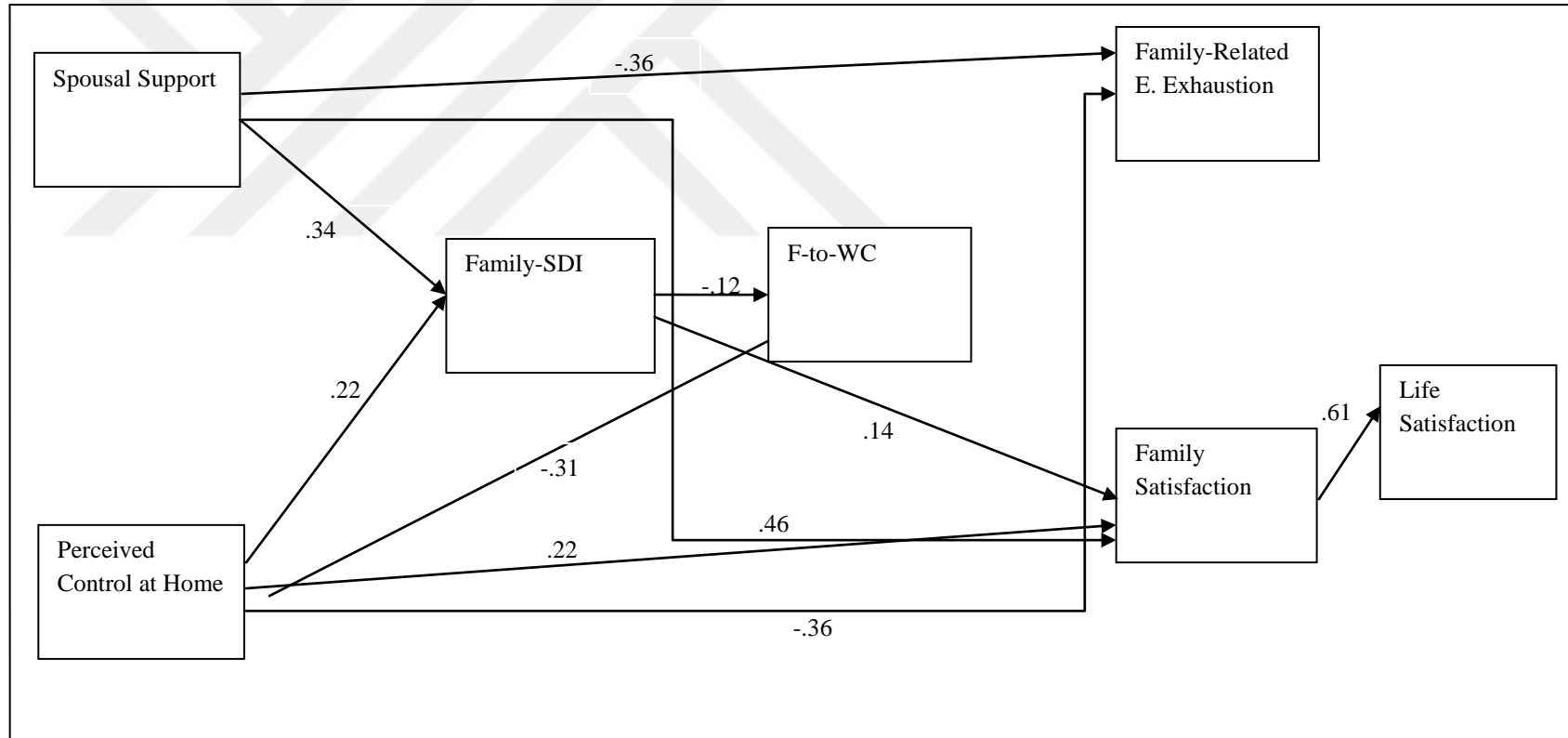

Note. All the estimates are standardized parameter estimates significant at $p \leq .05$. For simplicity, disturbances, inter-correlations between the independent variables (i.e., spousal support and perceived autonomy and control at home), correlated errors within the mediator variables (i.e., W-to- FC and F-to-WC) and within the outcome variables (i.e., marital satisfaction and marital exhaustion) are not included.

Figure 5 Path Analysis Results of the Modified Model for the Family Domain

Concerning life satisfaction, it was seen that while job satisfaction mediated the effects of work self-determined motivation on life satisfaction (*indirect effect* = 0.08, *z value* = 4.96, *S.E.* = .01, $p \leq .05$), family satisfaction mediated the relationship between family self-determined motivation and life satisfaction (*indirect effect* = 0.08, *z value* = 3.32, *S.E.* = .01, $p \leq .05$). Job satisfaction and family satisfaction also mediated the relationships between antecedents of self-determined motivation and life satisfaction. It was seen that both job characteristics and work support predicted life satisfaction via work-self determined motivation and job satisfaction (*indirect effect* = .08, *z value* = 4.96, *S.E.* = .00, $p \leq .05$; *indirect effect* = .08, *z value* = 4.81, *S.E.* = .03, $p \leq .05$, respectively). Similarly, perceived control and spousal support predicted life satisfaction both through family-self determined motivation and family satisfaction (*indirect effect* = .16, *z value* = 5.68, *S.E.* = .04, $p \leq .05$; *indirect effect* = .30, *z value* = 9.31, *S.E.* = .05, $p \leq .05$, respectively).

4.2.2. Testing of the Combined Effects of Motivation on WFC Dimensions

Hypothesis 2 concerned the combined effects of domain-specific motivational orientations on the experience of work-family conflict. In *Hypothesis 2a* it was predicted that individuals who displayed autonomous motivation toward family and controlled motivation toward work would experience work-to-family conflict, but not family-to-work conflict. Conversely, in *Hypothesis 2b*, it was expected that individuals who displayed autonomous motivation toward work and controlled motivation toward family would experience family-to-work conflict, but not work-to-family conflict. On the other hand, while *Hypothesis 2c* stated that individuals with autonomous motivation toward both family and work would experience the lowest levels of W-to-FC and F-to-WC, *Hypothesis 2d* maintained that individuals with controlled motivation toward both family and work would experience the highest levels of W-to-FC and F-to-WC. In order to test these hypotheses two separate 2 (autonomous vs. controlled motivation toward work) x 2 (autonomous vs. controlled motivation toward family) between-subjects ANOVA was conducted by using W-to-FC and F-to-WC as dependent variables. However,

since there were only fourteen subjects who had negative scores on family self-determination index, the autonomous –controlled motivation distinction was made by using median-split technique to equalize the group sizes. Thus, individuals who obtained scores below the median were assumed to have controlled motivation toward work/family domain whereas those who obtained scores above the median were assumed to have autonomous motivation toward work /family domain.

When ANOVA analysis was performed for W-to-FC dimension, results of the group mean comparisons revealed the expected patterns. That is, individuals who displayed controlled motivation toward both work and family domains reported highest levels of W-to-FC ($M = 3.18, S.D. = 1.07$) whereas individuals who displayed autonomous motivation toward both work and family domains reported lowest levels of W-to-FC ($M = 2.47, S.D. = 1.21$). On the other hand, mean scores of the individuals with controlled motivation toward work and autonomous motivation toward family were higher ($M = 2.99, S.D. = 1.29$) than of those with autonomous motivation toward work and controlled motivation toward family ($M = 2.91, S.D. = 1.17$). However, an examination of tests of between-subject effects yielded a non-significant interaction effect of motivation toward work and motivation toward family on W-to-FC; $F(1, 401) = 1.05, p > .05, \eta_p^2 = .003$ suggesting that these differences in group means were insignificant.

Similar patterns of results were obtained for F-to-WC dimension. An examination of group means indicated that while individuals with autonomous motivation toward both work and family domains reported lowest levels of F-to-WC ($M = 1.89, S.D. = .82$), those with controlled motivation toward both work and family domains reported highest levels of F-to-WC ($M = 2.48, S.D. = .91$). On the other hand, mean scores of the individuals with controlled motivation toward family and autonomous motivation toward work were higher ($M = 2.35, S.D. = .93$) than of those with autonomous motivation toward work and controlled motivation toward family ($M = 2.17, S.D. = .92$). However, since a non-significant interaction effect of motivation toward family and motivation toward work on F-to-WC was found ($F(1, 401) = .62, p > .05, \eta_p^2 = .002$), these observed differences in group means were all non-significant.

Taken together, these findings indicated that *Hypothesis 2* and its *sub-hypotheses 2a-2d* were not supported.

4.2.3. Moderating Influences of Work/Family Role Identification on the Cross-domain Effects of Work-Family Conflict

As shown in Figure 2b., *Hypothesis 14* and *15* stated that the cross-domain effects of work-to family conflict dimensions would vary as a function of individuals' identification with their work and family roles. Therefore, moderated regression analyses were performed to test these predictions.

In *Hypothesis 14*, it was expected that the relationship between W-to-FC and family satisfaction would be moderated by work role identification. More specifically, it was proposed that the negative effects of W-to-FC on family satisfaction would be stronger for the individuals who were high on work role identification than for those who were low on work role identification.

To examine this moderating effect of work role identification, regression analysis was performed by using Hayes' (2013) Process Macro Model 1. W-to-FC was entered into the equation as the independent variable and family satisfaction was utilized as the outcome variable. The sample size was bootstrapped to 5000, and conditional values at low and high values of work role identification, which served as the moderator variable in the model, were calculated, as proposed by Aiken and West (1991). Results, however, showed that neither work-role identification nor the interaction term had significant effects on family satisfaction ($b = .04$, $S.E. = .07$, $95\% CI [-.10, .17]$, $t = .572$, $p > .10$; $b = .05$, $S.E. = .06$, $95\% CI [-.06, .15]$, $t = .842$, $p > .10$, respectively). Thus, identification with the work-role was not associated with family satisfaction and the negative relationship between W-to-FC and family satisfaction did not change as a function of the level of work-role identification. Therefore, *Hypothesis 14* was not supported.

Regression analysis was repeated with the same procedures to test *Hypothesis 15*, which suggested that the relationship between F-to-WC and job satisfaction would be moderated by family-role identification. Since job

satisfaction was found to be significantly correlated with the control variables of age, gender, flexible hours, number of children and childcare support, these variables were entered as covariates. Although subjects' job tenures and marital years also seemed to be correlated with job satisfaction, these variables were not entered into the model because they displayed strong relationships with the age variable ($r = .74, p < .01$; $r = .79, p < .01$, respectively). Results of the moderated regression analysis revealed that among the control variables, only flexible working hours significantly predicted job satisfaction ($b = .36, S.E. = .08, 95\% CI [.20, .52], t = 4.366, p < .01$). Therefore, insignificant control variables were dropped to improve the model and moderated regression analysis was conducted once again by only controlling for the effects of flexible hours.

Findings revealed that, even after controlling for flexibility of working hours, identification with the family role significantly predicted job satisfaction ($b = .18, S.E. = .09, 95\% CI [.00, .36], t = 1.991, p = .05$), and, also moderated the relationship between F-to-WC and job satisfaction ($b = .22, S.E. = .09, 95\% CI [.00, .36], t = 2.498, p < .05, R^2 = .093, R^2_{\text{change}} = .014$).

Surprisingly, however, results of simple slope analysis showed that the negative relationship between F-to-WC and job satisfaction was stronger, not at high, but at low levels of family-role identification ($b = -.38, S.E. = .09, 95\% CI [-.56, -.19], t = -4.016, p < .05$). On the other hand, contrary to expectations, at high levels of family-role identification, the relationship F-to-WC and job satisfaction was insignificant ($b = -.06, S.E. = .10, 95\% CI [-.25, .12], t = -.688, p > .10$). These findings indicated that when the individuals are highly identified with their family-roles, the experience of family-to-work conflict does not result in a decrease in job satisfaction. However, when the individuals' identification with their family role is low, the effects of F-to-WC are more detrimental, leading to high levels of reduction in job satisfaction. Therefore, it can be said that *Hypothesis 15* was partially supported. Since these results are interesting and unexpected, they will be discussed more thoroughly in subsequent chapter. The simple slope test results are shown in Figure 6.

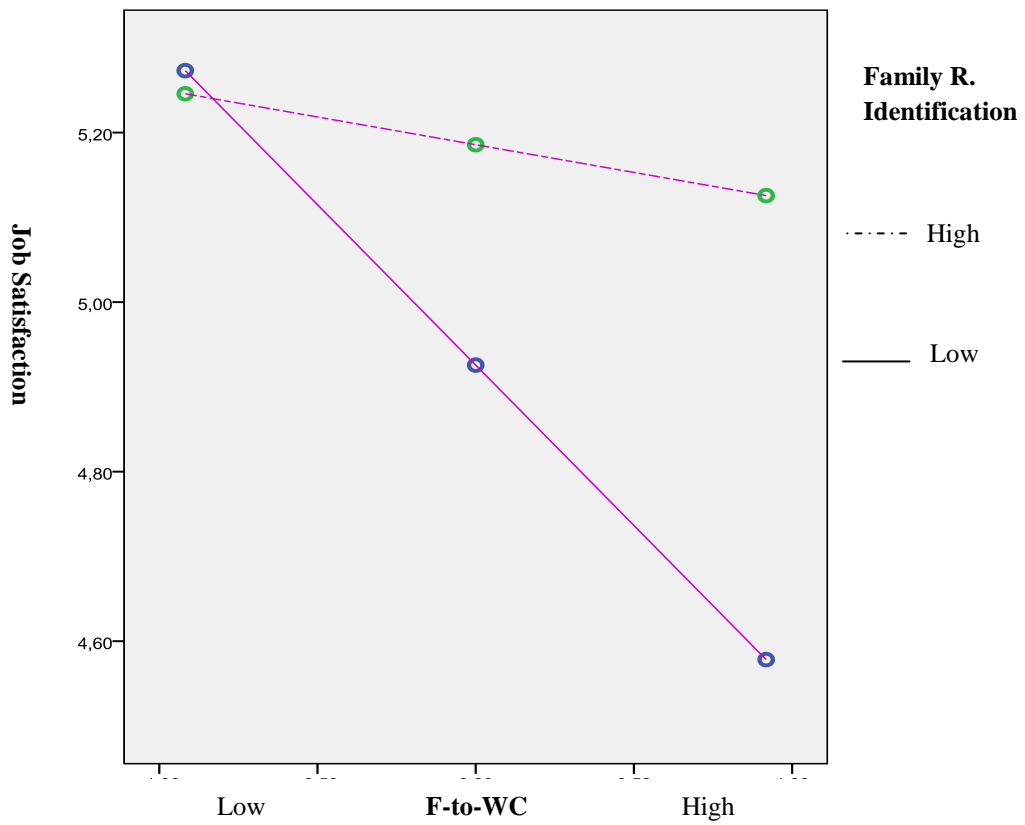

Figure 6. Interaction of Family-to-Work Conflict and Family Role Identification on Job Satisfaction

The results of the present study are summarized in Table 2. along with a list of the proposed hypotheses and the findings from the literature that support these results.

Table 2 Summary of Proposed Hypotheses, Results and Findings from the Literature

	Proposed Hypothesis	Result
H1a	Self-Determined (autonomous) motivation toward work will be negatively related to W-to-FC. Senecal, Vallerand, and Guay (2001) also found that Self-Determined (autonomous) motivation toward work predicted WFC through its effects on family alienation; (WFC overall measure)	S
H1b	Self-Determined (autonomous) motivation toward family will be negatively related to F-to-WC. Senecal, Vallerand, and Guay (2001) also found that Self-Determined (autonomous) motivation toward family predicted WFC through its effects on family alienation; (WFC overall measure)	S
H2	Perceived WFC will differ as a function of individuals' motivational profiles that reflect their motivations toward work and family. No study has tested this assumption.	NS
H2a	Individuals with autonomous motivation toward family but with controlled motivation toward work will experience W-to-FC, but not F-to-WC. No study has tested this assumption.	NS
H2b	Individuals with autonomous motivation toward work but with controlled motivation toward family will experience F-to-WC, but not W-to-FC. No study has tested this assumption.	NS
H2c	Individuals with controlled motivation toward both family and work will experience highest levels of W-to-FC and F-to-WC. No study has tested this assumption.	NS
H2d	Individuals with autonomous motivation toward both family and work will experience lowest levels of W-to-FC and F-to-WC. No study has tested this assumption.	NS
H3a	There will be a positive relationship between MPS and self-determined (autonomous) motivation toward work. Similar findings reported by several other studies (e.g., De Coomen et al., 2013; Gagne et al., 1997; Güntert, 2015; Millette & Gagne, 2008).	S
H3b	There will be a positive relationship between perceived work support and self-determined (autonomous) motivation toward work. Similar findings reported by several other studies (e.g., Fernet et al., 2010; Fernet et al., 2012; Gagne & Austin, 2010).	S
H4a	There will be a positive relationship between spousal support and self-determined (autonomous) motivation toward family. Similar findings reported by Senecal, Vallerand, and Guay (2001).	S
H4b	There will be a positive relationship between perceived control within the family environment and self-determined (autonomous) motivation toward family. Similar findings reported by several other studies (e.g., d'Ailly, 2003; Patrick, Skinner and Connell, 1993).	S
H5a	W-to-FC will be negatively related to job satisfaction Non-significant findings reported by several other studies (e.g., Adams & Jex, 1999; Aryee et al., 1999; O'Driscoll et al., 1992; Üzümcüoğlu, 2013)	NS
H5b	W-to-FC will be positively related to work-related emotional exhaustion (exhaustion at work). Similar findings reported by several other studies (e.g., Amstad et al., 2011; Karatepe and Tekinkuş 2006; Kossek & Ozeki, 1999).	S
H6a	F-to-WC will be negatively related to family satisfaction. Non-significant findings reported by several other studies (e.g., Aryee et al., 1999; O'Driscoll et al., 1992; Parasuraman et al., 1992).	NS

Note. **S**= Supported, **PS** = Partially Supported, **NS**= Not Supported

Table 2 Continued

	Proposed Hypothesis	Result
H6b	F-to-WC will be family-related emotional exhaustion (exhaustion at home). Inconsistent with the findings provided by Amstad et al. (2011); (family distress)	<i>NS</i>
H7	W-to-FC will be negatively, yet weakly, related to family satisfaction. Non-significant findings reported by several other studies (e.g., Aryee et al., 1999; O'Driscoll et al., 1992; Parasuraman, et al., 1992)	<i>NS</i>
H8	F-to-WC will be negatively, yet weakly, related to job satisfaction. Non-significant findings reported by several other studies (e.g., Kopelman, Greenhaus, Connolly, 1983; O'Driscoll et al., 1992; Parasuraman et al., 1992)	<i>NS</i>
H9a	Life satisfaction will be positively associated with job satisfaction. Similar findings reported by several other studies (e.g., Ahmad, 1996; Lapierre et al., 2008)	<i>S</i>
H9b	Life satisfaction will be positively associated with family satisfaction. Similar findings reported by several other studies (e.g., Ahmad, 1996; Lapierre et al., 2008)	<i>S</i>
H10a	Job characteristics will be directly and positively related to job satisfaction Similar findings reported by several other studies (e.g., Behson et al., 2000; Fried & Ferris, 1987; Johns et al., 1992).	<i>S</i>
H10b	Job characteristics will be directly and negatively related to work-related emotional exhaustion (exhaustion at work). Similar findings reported by several other studies (e.g., Griffin et al., 2012; Jansen et al., 1996; Kelloway & Barling, 1991).	<i>S</i>
H11a	Perceived work support directly and positively related to job satisfaction. Similar findings reported by several other studies (e.g., Babin & Boles, 1996; Bakker & Demerouti, 2008; Eisenberger et al., 1997).	<i>S</i>
H11b	Perceived work support directly and negatively related to work-related emotional exhaustion (exhaustion at work). Similar findings reported by several other studies (e.g., Baeriswyl et al., 2016; Bakker et al., 2003, Baruch-Feldman et al., 2002).	<i>S</i>
H12a	Spousal support will be directly and positively related to family satisfaction. Similar findings reported by several other studies (e.g., Acitelli & Antonucci, 1994; Cutrona & Suhr, 1994; Dehle et al., 2001).	<i>S</i>
H12b	Spousal support will be directly and negatively related to family-related emotional exhaustion (exhaustion at home). No study has tested this assumption for family-related exhaustion but similar findings reported for work-related emotional exhaustion (e.g., Halbesleben et al., 2010; Kulik & Rayyan, 2003; Rupert et al., 2009)	<i>S</i>
H13a	Perceived control at home will be positively related to family satisfaction. Similar findings reported by several other studies (e.g., Camp & Ganong, 1997; Miller et al., 1986; Madden, 1986).	<i>S</i>
H13b	Perceived control at home will be negatively related to family-related emotional exhaustion (exhaustion at home). No study has tested this assumption in family contexts but similar findings reported by the studies conducted in work settings (e.g., Karasek, 1979; Melamed et al., 1991; Teuchmann et al., 1999).	<i>S</i>
H14	The negative effects of W-to-FC on family satisfaction will be moderated by work role identification, such that the relationship between W-to-FC and family satisfaction will be stronger for the individuals who are high on work role identification than for those who are low on work role identification. Non-significant findings also reported by Noor (2004)	<i>NS</i>
H15	The negative effects of F-to-WC on job satisfaction will be moderated by family role identification, such that the relationship between F-to-WC and job satisfaction will be stronger for the individuals who are high on family role identification than for those who are low on family role identification. Similar findings reported by Bagger et al., (2008)	<i>PS</i>

Note. *S*= Supported, *PS* = Partially Supported, *NS*= Not Supported

CHAPTER 5

DISCUSSION

The current study was designed for two purposes: first, to discover the motivational underpinnings of work-family conflict by utilizing the basic assumptions of SDT (Deci & Ryan, 1985; Ryan & Deci, 2000), and to propose an comprehensive, integrative model that links fundamental determinants of motivation in both work and family contexts (i.e., job characteristics, work support, perceived control at home, spousal support) with the possible consequences of work-family conflict experiences (i.e., job satisfaction, work-related emotional exhaustion, family satisfaction, and life satisfaction). Moreover, the moderating effects of work/family role identification, respectively on the relationships between work-to-family conflict and family satisfaction, and between family-to-work conflict and job satisfaction were also examined.

To accomplish these purposes the current study was carried out in two stages. In the first stage, a pilot study was conducted in order to explore the underlying factor structures and to evaluate the psychometric properties of the measurement instruments by performing a series of EFAs and reliability analyses. In the second stage, the main study was conducted to confirm the factorial structures of the scales via CFAs, and to test study model and proposed hypotheses by performing path analyses.

Next sections will be devoted to evaluation of the study results in the light of the extant literature. Besides, theoretical and practical contributions as well as the limitations of the study will be discussed under relevant headings.

5.1. Discussion of the Study Findings

5.1.1. Hypotheses Testing and Main Findings

In line with the propositions of *Hypothesis 1a* and *Hypothesis 1b* results of the current study revealed that self-determined (autonomous) motivation toward work negatively predicted W-to-FC and self-determined (autonomous) motivation toward family negatively predicted F-to-WC. These findings are congruent with those reported by Senecal et al. (2001) and provide further support for the assumption that individuals who perform work (family) requirements for more autonomous reasons are less likely to perceive these demands as sources of conflict that impede their family (work) performance. However, relatively weak relationships found between motivational orientations and WFC dimensions, and the low amount of variances explained by these motivation types suggest that neither self-determined motivation toward work nor self-determined motivation toward family are, alone, very robust determinants of WFC. It seems that other variables, which have been traditionally considered as the antecedents of W-to-FC and F-to-WC such as work/family overload, role ambiguity, flexible working hours, presence of shiftwork, etc., are equally influential in predicting WFC experiences (see for example Allen, Johnson, Kiburz, & Shockley, 2013; Byron, 2005; Carlson & Perrewe 1999; Matthews, Bulger, & Barnes-Farrell, 2010; Michel et al., 2010). Still, these findings provide valuable information and call for a recognition of motivational aspects of work-family interplay. Hence, it is believed that future researchers can improve the predictive power of their studies by including these motivational factors into their models.

Hypothesis 2 maintained that motivation toward work and motivation toward family would interactively predict WFC. In other words, as indicated in *H2a-H2d*, it was believed that individuals would report different forms of WFC depending on their (autonomous vs. controlled) motivations toward work and toward family. Although findings from between-subjects ANOVAs showed the predicted patterns of differences among the groups' mean scores, the interaction terms of motivational

orientations did not approach to significance. Therefore, *Hypothesis 2* and its *sub-hypotheses H2a-H2d* were not supported. It is likely that these non-significant interaction effects result from the use of median split procedure to create autonomous and controlled motivation groups. According to Vallerand (1997), the distinction between controlled and autonomous motivations should be made on the basis of negative vs. positive values on Self-Determination Index (SDI). That is, individuals can only be said to have controlled motivation if they score negatively on SDI and only be said to have autonomous motivation if they score positively on SDI. However, this rationale could not be utilized in the present study because among 405 subjects only 14 of them obtained negative scores on Family Self-Determination Index (F-SDI). Therefore, participants' scores on Work Self-Determination Index (W-SDI) and Family Self-Determination Index (F-SDI) were split at their medians to create equal-sized controlled and autonomous motivation groups. Since the medians of F-SDI and W-SDI scores were higher than zero (*Median* = 1.33 for W-SDI; *Median* = 8.30 for F-SDI), participants who actually had autonomous motivation (in other words those with positive scores) were treated as if they had controlled motivation because they scored below the median. Hence, even individuals who obtained a score of 7.00 on F-SDI, for example, were assumed to have controlled motivation toward their families. It is very probable that such dichotomization led to non-significant results by reducing the power of analyses. Still, these findings can be considered as promising in the sense that with larger samples that involve higher numbers of control-motivated individuals, significant interaction effects can be attained.

In support of *Hypothesis 3a and 3b*, both MPS (characteristics of the job) and work support were found to have positive effects on autonomous (self-determined) motivation toward work. These findings are consistent with the prior research, which documented autonomous work motivation's positive relationships with job's characteristics (De Coomen et al., 2013; Gagne et al., 1997; Güntert, 2015; Millette & Gagne, 2008; Van den Broeck et al., 2008) and with work support (e.g., Fernet et al., 2010; Fernet, et al., 2012; Houkes et al., 2001). These results confirm that jobs

which provide autonomy, task variety, skill identity, task significance, and feedback, and work environments which are supportive in nature, are likely to satisfy employees' basic psychological needs (i.e., autonomy, competence and relatedness), and, in turn, enhance their autonomous motivation toward work.

Similar patterns of results were obtained for the family domain. Consistent with the predictions of *Hypothesis 4a*, spousal support was associated with higher levels of autonomous motivation toward family. Thus, individuals who receive (emotional) support from their partners are more likely to engage in family-related activities for autonomous (self-determined) reasons. This result concurs with Senecal et al.'s (2001) and Bouchard et al.'s (2007) studies which show the role of partner support in facilitating individual's self-determined motivation, most probably by its effects on basic need satisfaction.

Likewise, as proposed by *Hypothesis 4b*, perceptions of control regarding family-related issues significantly and positively predicted autonomous motivation toward family implying that individuals, who perceive themselves as having control over the events that concern their families, are more likely to have their competency need satisfied, and tend to display more autonomous forms of motivation toward their families. While this finding is consistent with those of the studies conducted in educational settings (Amoura et al., 2013; Amoura et al., 2014; d'Ailly, 2003; Patrick et al., 1993; Skinner et al., 1990), it also shows that the positive impact of perceived control on autonomous motivation is not limited to academic contexts.

Perceived control at home was also found to have a direct and negative impact on F-to-WC suggesting that autonomous motivation toward family only partially mediated this relationship. Although not predicted, this finding actually aligns with the previous research (Adams & Jex, 1999; Demokan, 2009; Duxbury, Higgins, & Lee, 1994; Michel, Kotrba, Mitchelson, Clark, & Boles, 2011; Thompson & Prottas, 2006) showing its negative associations with F-to-WC. It is possible that individuals who feel a strong sense of control over their family lives are better able to set their priorities, use efficient time-management strategies, effectively cope with family-related stressors, and eventually, experience lower levels F-to-WC.

In the current study, it was expected that autonomous motivation toward work and toward family would indirectly predict satisfaction related outcomes through their effects, respectively, on W-to-FC and F-to-WC. However, results of path analyses showed that both autonomous work motivation and autonomous family motivation had direct impacts on job and family satisfaction. These results indicate that individuals who engage in work/family related activities for more autonomous reasons are likely to report higher levels of work/family satisfaction. It may be that because autonomous motivation involves integration of an activity with one's self, finding meaningfulness in the activity and also performing the activity for enjoyment, this form of motivation is accompanied with positive emotions and vitality and eventually enhance individuals' appraisals of work and family (Graves & Luciano, 2103; Vallerand et al. 2003). These findings are consistent with the SDT literature which has documented that autonomous motivation directly yields more desirable and positive outcomes including job and relationship satisfaction (Blais et al., 1990; Gaine & La Guardia, 2009; Gillet, Fouquereau, Lafreniere, & Huyghebaert, 2016; Graves & Luciano, 2013; Güntert, 2015; Knee, Patrick, Nathaniel, Nanayakkara, & Neighbors, 2002; Patrick et al., 2007; Millete & Gagne, 2008; Van den Broeck, Lens, De Witte, & Van Coillie, 2013).

When the relationships between autonomous motivations and satisfaction outcomes were examined, it was seen that the strength of the relationship between autonomous family motivation and family satisfaction was much lower than that of between autonomous work motivation and work satisfaction. This difference in the magnitude of the relationships may be due to the restriction of scores on F-SDI and family satisfaction. As can be seen in Table 1., the scores of the participants were relatively high on these two variables ($M=7.76$ over $(\pm)12$, $S.D.= 3.12$ for F-SDI; $M=5.76$ over 7 , $S.D. = 1.16$ for family satisfaction). This means that most of the participants reported high levels of autonomous motivation toward their families and experienced great levels of family satisfaction. Although social desirability issues might be a concern here, it is more probable that these scores reflect a real tendency of individuals to be more autonomously motivated and satisfied when it comes to

their families. After all, considering that the study sample involved only married individuals, it would be very difficult for subjects to retain their marriages with high levels of controlled motivation and dissatisfaction.

As far as the outcomes of WFC are concerned, the results of the study yielded that neither W-to-FC nor F-to-WC had associations with job and family satisfaction. Although correlation analyses revealed the expected negative relationships between WFC dimensions and satisfaction outcomes (see Table 1.), these relationships, became non-significant in path analyses after controlling for the direct effects of autonomous motivation and its proposed antecedents on job and family satisfaction. Therefore, *Hypothesis 5a*, which predicted a negative relationship between W-to-FC and job satisfaction, and *Hypothesis 6a*, which predicted a negative relationship between F-to-WC and family satisfaction, were disconfirmed by the data. Likewise, *Hypothesis 7*, which predicted a negative but small relationship between W-to-FC and family satisfaction, and *Hypothesis 8*, which predicted a negative but small relationship between F-to-WC and job satisfaction were also rejected. While these findings are in congruence with some of past research that failed to find within or cross-domain effects of W-to-FC (Adams & Jex, 1999; Aryee, et al., 1999; O'Driscoll, et al., 1992; Qu & Zhao, 2012; Üzümcüoğlu, 2013) and F-to-WC (Aryee et al., 1999; Frye & Breugh, 2004; O'Driscoll et al., 1992; Parasuraman et al., 1992; Pattusamy & Jacob, 2016), it may be premature to jump to the conclusion that conflict experiences have no effect on work and family satisfaction. Rather, it seems that job characteristics, work support, and autonomous work motivation are more robust predictors of job satisfaction than W-to-FC and F-to-WC. In the same vein, spousal support, perceived control at home, and autonomous motivation appear to be more influential in determining family satisfaction than F-to-WC and W-to-FC. Indeed, small, at best, moderate WFC-satisfaction correlations found in meta-analytic studies (Amstad et al., 2011; Ford et al., 2007; Kossek & Ozeki, 1998, Shockley & Singla, 2011) provide support for this argument. Moreover, these results, as noted by Allen et al. (2000), Byron (2005) and Frone et al. (1992), underscore the importance of using comprehensive models that not only focus on

WFC-outcome relationships, but also involve the possible antecedents of WFC and of its proposed outcomes. For, studies that limit their scopes to WFC and its consequences without controlling for the effects of other factors that may influence work/family related outcomes are likely to give a misleading and incomplete picture. In fact, this may be the primary reason why different researchers come up with different results regarding the effects of WFC on important work, family and health related outcomes.

The presence of moderator variables may also be responsible for these non-significant relationships. Indeed, the moderated regression analysis, which revealed that F-to-WC reduced job satisfaction only at low levels of family identification, provides support for this line of reasoning. Hence, there may be other factors affecting WFC-satisfaction relationships. For example, in the literature, cultural context (Lu et al., 2010; Spector et al., 2007), gender (Amstad et al., 2011), coping styles (Aryee et al., 1999), locus of control (Hsu, 2011) are shown to moderate the relationships between WFC dimensions and role satisfactions.

As far as the relationships between WFC and emotional exhaustion are concerned, it was seen that W-to-FC was a significant predictor of work-related emotional exhaustion (emotional exhaustion at work). Thus, in support of *Hypothesis 5b*, results indicated that individuals who frequently experienced interferences from work domain to family domain were more likely to suffer from work-related emotional exhaustion. This result concurs with the findings of a large number of studies showing that W-to-FC (or WFC overall) leads to emotional exhaustion/ burnout (Allen et al., 2000; Amstad et al., 2011; Grzywacz et al., 2007; Karatepe & Tekinkuş, 2006; Nohe, Meier, Sonntagand, & Michel, 2014; Reichl, Leiter, & Spinath, 2014; Rubio et al., 2015; Rupert et al., 2009; Senecal et al., 2001; Zhang, Griffeth & Fried, 2012).

In the current study, it was predicted that WFC dimensions would not have cross-domain effects on exhaustion outcomes. For, considering that any interference from work domain to family domain, for example, signifies the presence of excessive work demands (or work overload), it was believed that one would

experience exhaustion only within the work domain. Contrary to expectations, however, results revealed a cross-domain effect for W-to-FC by revealing its positive link with also family-related exhaustion (emotional exhaustion at home). These results imply that feelings of strain and fatigue resulting from W-to-FC spills over into the family domain and make individuals feel drained from their family lives, as well.

Surprisingly, on the other hand, F-to-WC was not found to predict family-related exhaustion (emotional exhaustion at home). Hence, *Hypothesis 6b* was not supported. While correlation analyses revealed a moderate positive relationship between F-to-WC and emotional exhaustion at home (see Table 1.), as in the case of satisfaction outcomes, this association turned out insignificant when the effects of spousal support, perceived control at home, and W-to-FC were partialled out in the path analysis. Thus, it appears that (lack of) spousal support, (lack of) perceived control at home and W-to-FC are more predictive of family-related exhaustion than F-to- WC. It is also possible that individuals' feelings of exhaustion regarding their family lives result from the factors other than F-to-WC such as negative affectivity or neuroticism, frequent conflicts between partners, ill-health of a family member, or economic problems, which were not considered in the present study. Although this finding contradicts with the past research that documented positive associations between F-to-WC and strain related variables including emotional exhaustion and family distress (Amstad et al., 2011; Allen, 2000; Burke & Greenglass, 2001; Grandey & Cropanzano, 1999; Nohe et al., 2014), it should be noted that the current study is first to examine individuals' emotional exhaustion within the family domain. Therefore, more research is warranted to arrive at firm conclusions.

Taken together, these findings show that W-to-FC has more negative consequences than F-to-WC for individuals. They also suggest that WFC (more specifically W-to-FC) is more predictive of exhaustion related outcomes whereas autonomous motivation is more predictive of satisfaction related outcomes. The relationship between W-to-FC and work-related emotional exhaustion was especially remarkable ($\beta = .45$) and W-to-FC was able to explain 21% of the variance in work-

related exhaustion over and above job characteristics and work support. This result provides evidence for the *scarcity hypothesis*, which maintains that the continuous strive for juggling work and family demands creates fatigue and stress, and eventually, by consuming individuals' limited resources, leads to feelings of emotional depletion. It is also consistent with Amstad et al.'s (2011) findings that showed, except for its intense relationship with organizational citizenship behaviors (-.63), W-to-FC was most strongly associated with strain/stress related outcomes including burnout/exhaustion (.38), work-related stress (.49), family-related stress (.23), psychological strain (.35) and general stress (.54). Furthermore, it aligns with Nohe et al.'s (2014) results documenting moderate to strong relationships between W-to-FC and its strain related consequences. Lastly, the correlation analyses which yielded that W-to-FC was consistently more closely associated with work-related outcomes whereas F-to-WC was consistently more closely associated with family related outcomes (see Table 1.), as well as the path analyses' results which showed that W-to-FC displayed a stronger relationship with work-related exhaustion than with family-related exhaustion, undermine the *cross-domain hypothesis* and like some other past research (Amstad et al., 2011; Frye & Breugh, 2004; Grandey et al., 2005; Kossek & Ozeki, 1998; Nohe et al., 2014; Shockley & Singla, 2011; Voydanoff, 2001; Wayne et al.; 2002) lend support for the *matching hypothesis*.

When the relationships among the satisfaction outcomes were examined, it was observed that, in line with the propositions of *Hypothesis 9a* and *9b* and the relevant prior research (e.g., Ahmad, 1996; Beutell & Wittig-Berman, 1999; Carlson & Kacmar, 2000; 1992; Haar et al., 2014; Hsieh & Huang, 2017; Lapierre et al., 2008; Margolis & Myrskylä, 2013; Newman, Tay, & Diener, 2014; Rice et al., 1992), both job and family satisfaction predicted life satisfaction. Thus, individuals who experienced greater job and family satisfaction also tended to report greater life satisfaction. The remarkably strong relationship between family and life satisfaction ($\beta = .61$) signified that individuals' feelings of life satisfaction was largely determined by their family satisfaction. This intense relationship between family satisfaction and life satisfaction is likely to stem from Turkey's cultural

context. Turkey has a collectivistic culture that emphasizes strong family ties (Aycan, 2008; Hofstede, 1991) and as indicated by Haar et al. (2014) people of collectivist societies primarily work to improve their families' financial status and well-being. Therefore, it is not surprising that for Turkish people, family satisfaction, rather than job satisfaction, is the main contributor to life satisfaction.

Regarding the direct relationships between antecedents of motivation and WFC outcomes in work and family domains, the results were all, as predicted. Compatible with *Hypothesis 10a* and a vast number of early studies (Behson et al., 2000; Brief & Aldag, 1975; Fried & Ferris, 1987; Hackman & Oldham, 1975, 1980; Humphrey et al., 2007; Judge et al., 2000; Liden et al., 2000; Renn & Vanderberg, 1995; Sultan, 2012; Ünüvar, 2006; Wall et al., 1978; see also Bilgiç, 2008, and Oldham and Fried, 2016 for reviews), characteristics of the job were shown to be positively related to job satisfaction, providing additional evidence for the one of the major assumptions of JCM (Hackman & Oldham, 1975, 1980). Confirming *Hypothesis 10b*, job characteristics also negatively predicted emotional exhaustion indicating that jobs with highly motivating designs ease the effects of stress and boost employee well-being. This finding, indeed, concurs with the extant research on job design (Demerouti et al., 2010; Griffin et al., 2012; Humphrey et al., 2007; Jansen et al., 1996; Kelloway & Barling, 1991; Lambert, Hogan, Dial, Jiang, & Khondaker, 2012; Van den Broeck et al., 2008; Xanthopoulou et al., 2007; also see Oldham and Fried, 2016).

Likewise, *Hypothesis 11a*, which predicted a direct, positive relationship between work support and job satisfaction, and *Hypothesis 11b*, which predicted a direct, negative relationship between work support and job satisfaction were supported by the data. These results align with the existent literature (e.g., Baeriswyl et al., 2016; Bakker & Demerouti, 2007; Bakker et al., 2003; Burke et al., 2007; Fernet et al., 2010; Gözükara & Çolakoğlu, 2015; Kale, 2015; Kula & Güler, 2014; Tang et al., 2014; Tayfur & Arslan, 2013; Yürür & Sarıkaya, 2012), and once again show the beneficial and protective effects of supportive work environments.

Within the family domain, the salutary effects of support were also observed. As predicted by *Hypothesis 12a* and *Hypothesis 12b*, spousal support shown to directly and positively predict family satisfaction, and directly and negatively predict family-related emotional exhaustion. Like previous research (e.g., Acitelli & Antonucci, 1994; Cutrona & Suhr, 1994; Dehle, Larsen, & Landers, 2001; Halbesleben et al., 2010; Halbesleben et al., 2012; Julien & Markman, 1991; Kulik & Rayyan, 2003; Overall et al., 2010; Rupert et al., 2009; Xu & Burleson, 2004) these findings signify the importance of partner support in enhancing one's family satisfaction and mitigating the feelings of emotional exhaustion.

Similarly, in line with *Hypothesis 13a* and *Hypothesis 13b*, individuals' perceived sense of control over their family lives directly and positively predicted their family satisfaction, and directly and negatively predicted their family-related emotional exhaustion. These results are, again, in congruence with the prior research that demonstrated the positive impacts of perceived control in both family and work contexts (e.g., Camp & Ganong, 1997; de Rjick et al., 1998; Häusser et al., 2010; Karasek, 1979; Melamed et al., 1991; Madden, 1987; Madden & Janoff-Bulman, 1981; Miller et al., 1986; Myers & Booth, 1999; Teuchmann, et al., 1999; Park et al., 2014).

As far as the moderating roles of work/family role identification in the relationships between WFC dimensions and their cross-domain effects are concerned, the results were unexpected, however. *Hypothesis 14*, which suggested that work role identification would moderate the association between W-to-FC and family satisfaction, was not supported. Thus, contrary to predictions, the relationship between W-to-FC and family satisfaction did not change and remained insignificant at both high and low levels work-role identification. Hence, it seems that individuals' family satisfaction is not affected by work-related variables. Although this finding concurs with Bhowon's (2013) study, which was also unable to reveal a significant moderating role of work identification, several explanations can be offered. First, as previously mentioned, people's attitudes regarding their

family lives might be primarily determined by family-related factors such as spousal support, conflicts with the partner, or high marital demands etc.

These factors may also interact with W-to-FC experiences to predict family satisfaction. Secondly, it may be that work identification has a joint impact with gender on the relationship between W-to-FC and family satisfaction. Considering that Turkish society predominately holds traditional gender roles that conceptualize men primarily as “breadwinners” and women primarily as “homemakers” (Kabasakal & Bodur, 2002), the aversive effect of W-to-FC on family satisfaction might be apparent for only women who are highly identified with their work roles. For, women who highly value their work may be more negatively affected by an intrusion from the work domain because they are at the same time aware of the cultural stereotype that working is an extra role for women and their primary responsibility is to take care of the family. On the other hand, women who do not define themselves in terms of their work role, may be less likely to permit work demands to interfere their family life and to allow these occurrences to reduce their family satisfaction. Conversely, men who are highly identified with their work role may be more tolerant to negative impacts of W-to-FC experiences because such intrusions are congruent with their gender roles. Men who do not perceive that work is a central aspect of their identity, however, may be more frustrated by these work interferences and may feel greater family dissatisfaction. Indeed, many researchers (e.g., Aycan & Eskin, 2005; Bagger et al. 2008; Carlson & Kacmar, 2000; Eby et al. 2005; Lee, Zvonkovic, & Crawford, 2014; Knežević, Gregov, & Simunić, 2016) pointed out that the experiences and consequences of WFC may differ among men and women as a result of these gender-segregated roles. To arrive at firm conclusions, however, future research should focus on exploring the interactive moderating effects of gender and role identification on WFC and its possible consequences.

Regarding *Hypothesis 15*, although family role identification was found to moderate the influence of F-to-WC on job satisfaction, the results were surprising in the sense that, the relationship between F-to-WC and job satisfaction was

exacerbated not at high but at low levels of family-role identification; signifying the buffering role of family identification against the detrimental cross-domain effects of F-to-WC. While this finding contradicts with the premise of *Hypothesis 15*, it is still in line with the results provided by Bagger et al. (2008). In their study, the researchers examined the role of family identification in the relationships between F-to-WC, job satisfaction, and job distress, and reported that the while at high levels of family identification the positive impact of F-to-WC on job stress weakened; it was amplified at low levels of family identification. Moreover, they found that the relationship between F-to-WC and job satisfaction became negative and significant only at low-levels of family identification. At high-levels of family identification, however, F-to-WC did not have an effect on job satisfaction, as in the present study. Taken together, these findings suggest that when individuals consider their family as an important and salient part of their self-identities, they do not feel bothered by any transgression from family domain to work domain. On the other hand, such transgressions trigger job dissatisfaction and become more disturbing to individuals who do not identify with their families since it is likely that these individuals do not want to be preoccupied by family-related issues. Although this line of reasoning is plausible, considering the inconsistent findings in the literature (see Carlson & Kacmar, 2000; Carr et al. 2008; Greenhaus et al., 2001; Noor, 2004; Thoits, 1992 for example), however, more research is warranted to arrive at more definite conclusions. Furthermore, as in the case of work-role identification, the additional moderating role of gender in this relationship should be examined in future studies.

5.1.2. Mediations and Indirect Effects

In line with the expectations, the relationship between job motivating characteristics and work-related emotional exhaustion was partially mediated by both autonomous motivation toward work and W-to-FC. This finding suggested that when individuals perceive their jobs as highly motivating, they are more likely to display autonomous motivation toward their work, in turn, less likely to experience W-to-FC, and, in turn, less likely to suffer from emotional exhaustion at work

contexts. To the knowledge of the researcher, although there is no other study that simultaneously examined the mediating roles of autonomous motivation and W-to-FC in job characteristics- exhaustion relationship, these findings concur with the results provided by Koekemoer and Mostert (2006) and Janssen et al. (2004), which revealed that the relationship between job characteristics and emotional exhaustion was partially mediated by occurrences of work-family conflict. Moreover, these results, in part, align with those reported by Van den Broeck et al. (2008), which yielded that the relationship between job characteristics (more specifically, task autonomy, skill utilization, and positive feedback) and emotional exhaustion was partially mediated by basic need satisfaction. The direct link found between job characteristics and job exhaustion, also signifies that there are other mechanisms underlying this relationship. In the literature, personal resources such as self-efficacy, self-esteem, and optimism are suggested to mediate the association between job characteristics and emotional exhaustion (Xanthopoulou et al. 2007).

Similarly, as predicted, the relationship between work support and work-related emotional exhaustion was found to be partially mediated by both autonomous motivation toward work and W-to-FC. This finding suggests that individuals who perceive their work environments as supportive are likely to display greater autonomous motivation toward their work, in turn, experience lower levels of W-to-FC, and eventually, report lower levels of emotional exhaustion at work contexts. These results are again, congruent with those reported by Senecal et al. (2001) that documented mediating effects of autonomous work motivation and WFC on supervisory support-emotional exhaustion relationship. As in the case of job characteristics, work support also had a direct impact on work-related emotional exhaustion, indicating the possible presence of other mediating variables such as role ambiguity, role overload and coping mechanisms.

Since path analysis results revealed that W-to-FC was also predictive of family-related emotional exhaustion, both job characteristics and work support had indirect effects on this construct. That is, higher levels of job motivating characteristics and work support, resulted in higher levels of autonomous motivation

toward work, and, in turn, led to lower levels of W-to-FC, which, in turn, caused lower levels of emotional exhaustion at home. Hence, it seems that individuals who perceive their jobs as highly motivating and their work environments as supportive are also less vulnerable to feelings of exhaustion at family contexts.

Although it was believed that, the relationship between job characteristics and job satisfaction would be partially mediated by autonomous motivation toward work and W-to-FC, the association between W-to-FC and job satisfaction was insignificant. Therefore, W-to-FC was not able to mediate the path from job characteristics to job satisfaction. However, in line with the Millette and Gagne's (2008) study findings, this relationship was partially mediated by autonomous motivation toward work. For the very same reason, the link between work support and job satisfaction was partially mediated only by autonomous motivation toward work. These results concur with previous research showing the mediating effects of autonomous motivation between coworker/supervisory support and job satisfaction (e.g., Deci et al., 1989; Güntert, 2015; Moreau & Mageau, 2012).

Job characteristics and work support were also found to indirectly contribute to the feelings of life satisfaction through their effects on autonomous work motivation and job satisfaction suggesting that the beneficial effects of these constructs are not limited to work settings.

Within the family domain, similar patterns of relationships were observed. Again, although it was expected that the paths flowing from spousal support and perceptions of control at home would be partially mediated by autonomous motivation toward family and F-to-WC, because of the non-significant relationship found between F-to-WC and family satisfaction, autonomous motivation was the only variable acting as mediator in the proposed paths. These results suggested that when individuals perceive themselves as having control over the family-related issues and receive support from their spouses, they are more likely to display autonomous motivation toward their families, and in turn, experience greater levels of family satisfaction. Although there is no known study that examined the mediating role of autonomous motivation in perceived control-satisfaction

relationship in family contexts, the results are in congruence with those reported by the studies conducted in educational settings (see for example Amoura et. al, 2013; Boggiano, Main, & Katz, 1988, & Amoura, Berjot & Gillet, 2013). Similarly, the mediating effect of autonomous motivation between spousal support and relationship satisfaction was not examined before. However, this finding is line with previous close relationships research, which documented the positive effects of partner support and basic need satisfaction on relationship quality (e.g.,La Guardia et al., 2000; La Guardia et al., 2007; Ryan et al., 2005; Ratelle, Simard, & Guay, 2013; Knee et al., 2002).

As in the work domain, results of the path analysis also revealed that both spousal support and perceptions of control predicted life satisfaction via autonomous family motivation and family satisfaction. These findings indicated that higher levels of perceptions of control and spousal support, led to greater autonomous motivation toward family, and in turn, resulted in higher levelsof family satisfaction, which eventually transformed into increased levels of family satisfaction.

5.1.3. Correlations of the Study Variables

Although exploring the relationships among the demographical variables and the variables of interest was not the main thrust of the current study, some of the correlational analyses' results (see Table 1.) also offer important insights regarding conflict experiences that require highlighting.

First of all, it was seen that gender emerged an important construct that displayed significant relationships with most of the study variables. The t-test analyses revealed that female participants reported higher levels of W-FC and self-determined motivation toward their family whereas male participants reported higher levels of work-role identification and job satisfaction, and rated their jobs as highly motivating. While these findings are consistent with the early research that pronounced same gender effects on conflict experiences (Aycan & Eskin, 2005; Giray & Ergin, 2006; Frone et al., 1992; Maume 2006), autonomous motivation (Fernet, 2010; Senecal et al., 2001; Vallerand, 1997), work- role identification/

involvement (Knežević et al., 2016), job satisfaction (Loscocco & Bose, 1998), and job characteristics (Karasek et al., 1998), they also signify the sailence of gender role attitudes in Turkish society as there are still traditional attitudes toward the work roles of the women. Furthermore, the finding that women reported higher levels of emotional exhaustion at both work and family contexts also indicates the challenging situation that Turkish women need to face. Although Turkish women are becoming increasingly more visible in the professional life (Aycan & Eskin, 2005), they, at the same time, still undertake great responsibility at home (Sevim, 2006 cited in Bıçaksız, 2009). It seems that while trying to effectively and simultaneously manage these roles, Turkish women experience high levels of stress and suffer from ill health.

As far as the associations between flexible working hours and WFC dimensions are concerned, it was observed that although participants who worked with flexible schedules experienced lower levels of W-to-FC, they reported higher levels of F-to-WC. While the negative relationship between flexibility of work schedules and W-to-FC has already been established in the literature (see Ahmad, 2008; Allen et al., 2012; Burke et al., 1980; Byron, 2005; Greenhaus & Beutell, 1985; Yıldırım & Aycan, 2008 for example), it was interesting to find out that this flexibility contributed to experiences of F-to-WC. It appears that because employees working with flexible schedules are able to decide when to start (or finish) the workday depending on their needs, they can deal with family-related issues during standard working hours. However, it seems that such involvement with family responsibilities within the workday makes individuals feel missing the work and, eventually leads to greater perception of blurring of the work-family boundaries.

In terms of work support, it was seen that while supervisory support and coworker support displayed equivalent correlations with W-to-FC ($-0.14, p < .01$), supervisory support had stronger correlation with autonomous work motivation ($.32, p < .01$), than the coworker support ($.21, p < .01$) although the difference was small. Hence, it seems that supervisory support is particularly important in fostering employees' autonomous motivation at work.

5.2. Strengths and Contributions of the Study

It is expected that the current study will contribute to the existing literature in a number of ways. First, the present study is one of the two studies (see also Senecal et al., 2001) that investigated the motivational aspects of work-family conflict from the perspective of Self-Determination Theory (Deci & Ryan, 1985; Ryan & Deci, 2000). Furthermore, it is the only known study, which examined both unique and combined effects of motivational orientations (motivation toward work and motivation toward family) separately on W-to-FC and F-to-WC dimensions of work-family conflict. While the current study was unable to find joint effects of motivational orientations on WFC dimensions, both autonomous motivation toward work and autonomous motivation toward family were shown to have direct effects on W-to-FC and F-to-WC. Although these relationships between autonomous motivations and WFC dimensions were not as strong as one would desire, these findings still show that self-determined (autonomous) motivation toward work and self-determined (autonomous) motivation toward family are significant determinants of W-to-FC and F-to-WC, and explain some variance in these constructs. In this sense, it is believed that findings of this research open a promising avenue for exploring and understanding the motivational processes underlying WFC. Future researchers may, for example, try to replicate these findings by using similar models or strive to increase the predictive power of their studies by incorporating these constructs into their research designs.

Second, although a considerable effort has been devoted to distangle the effects of W-to-FC and F-to-WC on work and family domain variables in the literature, the results have been generally inconclusive. While some studies revealed findings that supported the *cross-domain hypothesis* (Aycan & Eskin, 2005; Frone et al., 1992; Frone et al., 1997; Ford et al., 2007), others obtained contradictory results that favored the *matching hypothesis* (Amstad et al., 2011; Kossek & Ozeki, 1998; Nohe et al. 2014; Voydanoff, 2001; Wayne et al., 2002). On the other hand, in the present study, both hypotheses were simultaneously tested to compare the impacts of two forms of conflict on domain-specific outcomes. Results were, indeed,

enlightening. For, the patterns of correlations among WFC dimensions and their suggested outcomes, as well as the magnitude of the relationships between W-to-FC, and work-related and family-related exhaustion found in the path analysis, disconfirmed the cross-domain hypothesis and provided further evidence for the matching hypothesis. In this respect, the current study is expected to guide future researchers in deciding between these two rival hypotheses.

Third, in the present study a comprehensive, conceptual model that integrates motivation related variables with fundamental outcomes of work-family conflict is proposed. Although some of relationships between the constructs utilized in the present study has been separately examined by different studies, to the knowledge of the researcher, the current study represents the first attempt to explore the associations between determinants motivational orientations (i.e., job characteristics, work support, spousal support, perceptions of control at home) and major outcomes of work family conflict (i.e., emotional exhaustion at work and at home, job satisfaction, family satisfaction, life satisfaction). Moreover, by testing the simultaneous mediating effects of motivation types, work-family conflict and satisfaction variables, the present study is believed to deepen our understanding regarding the mechanisms underlying these experiences. In this way, the current study extends the extant literature.

Another major contribution of the study concerns the examination of the moderating roles of work/family role identification in WFC dimensions- domain satisfactions relationships. Although, the importance of individuals' role priorities in work-family research has been recognized in the literature, most studies either focused on examining the direct effects of these constructs on conflict experiences (e.g., Adams et al., 1996; Beutell & Wittig-Berman, 1999; Byron, 2005; Frone et al., 1992; Parasuraman & Simmer, 2001) or on exploring their moderating roles in the relationship WFC and its antecedents (e.g., Bıçaksız, 2009; Carlson & Kacmar, 2000; Day & Chamberlain, 2006; Frone & Rice, 1987; Greenhaus & Beutell, 1985). Yet, to the knowledge of the researcher, there have been only five studies that attempted to unveil the moderating effects of these role identifications on the

relationships between WFC and its possible outcomes. Furthermore, as mentioned before, in most cases these studies revealed incompatible findings (e.g., Bagger et al, 2008; Bhrown, 2013; Carr et al, 2008; Noor, 2004). By being one of the few studies examining the aforementioned moderating effects of role identifications, the current study strives to expand our understanding concerning the joint effects of role priorities and conflict experiences on satisfaction-related outcomes. Moreover, by showing that low identification with the family role amplifies impact of F-to-WC on job satisfaction, this research provides valuable insight regarding how people's values affect their conflict experiences.

As previously mentioned, the sampling strategy utilized in WFC research has been criticized by several researchers (Allen et al., 2000; Kossek & Ozeki, 1998; Eby et al. 2000) Although it has been established that role conflict is a concern primarily to employed parents (Byron, 2005; Ford et al., 2007) , in many studies, the sample also involved individuals that were neither married nor had children (e.g., Carlson et al., 2000; Demokan, 2009; Thompson & Blau, 1993; Üzümcüoğlu, 2013; . Moreover, in most cases, the data was obtained from participants working in the same organization or in the same industry (e.g., Aycan & Eskin, 2005; Netemeyer et al., 1996; Rice et al., 1992; Stoeva, Chiu, & Greenhaus 2002) The sample of in the present study, on the other hand, compromised only married, employed individuals who had children younger than 18 years old. Furthermore, employees from variety of occupations participated in the study. All these features are considered to be major strengths of this research.

The last, but not the least contribution of the present study concerns the development and adoption of motivation scales. As mentioned before, in order to measure participants' motivation in work contexts the English version of WEIMS which was originally developed by Tremblay et al. (2009), was adapted to Turkish culture by the current study. Similarly, to assess individuals motivation in family context a new measurement was developed by the researcher by relying on the work of Senecal and Vallerand (1999) and major assumptions of SDT. Both of these scales are shown to have adequate reliabilities ranging from .59 to .83 across the

dimensions. The correlation, as well as path analyses' results also demonstrated the concurrent validity of these scales by revealing the expected pattern of relationships among the constructs measured by these scales and other variables utilized in the study. Overall, since these findings suggest that the scales possess adequate psychometric properties, researchers interested in examining motivation in work and family context may benefit from utilizing these instruments. Indeed, considering that contrary to expectations, the factor analyses revealed only three dimensions rather than six, it is believed that use of the scales in future research may help us to better understand the factorial patterns underlying these scales.

5.3. Practical Implications

Various practical implications follow from the study findings. First of all, considering the positive relations between W-to-FC and emotional exhaustion (both at work and at home), it is essential for organizations to take active steps to reduce occurrences of work-family conflict and to alleviate its negative impacts on employee well-being. Implementing training programs that focus on time-management, stress management, coping strategies, relaxation techniques and conflict resolution may help employees effectively deal with the multiple demands of work and family roles, experience decreased levels of strain, and achieve a greater balance between their work and family lives.

The correlation analyses conducted in the present study also highlight the importance of flexible work arrangements for employees. As previously mentioned, flexibility of working hours was found to be associated not only with reduced levels of W-to-FC, but also with heightened levels of job satisfaction and autonomous motivation toward work, and decreased levels of emotional exhaustion. Therefore, organizations should allow employees to change their working times in order to improve work-related attitudes and employee well-being. Alternatively, organizations may offer compressed workweeks, job sharing, telecommuting, work from home opportunities to assist employees in structuring and organizing work responsibilities according to their needs.

Introduction of other family-friendly practices such as reducing work hours, offering on or off-site childcare facilities, limiting the frequency of overtime and work-related vacations, permitting employees to take maternity, paternity or elder-care leaves may also prevent work-family related problems. An important point made by scholars (Frye & Breugh, 2004; Poelmans, 2001; Thompson, Beauvais, & Lyness, 1999), however, is that the mere presence of such family-friendly organizational policies does not guarantee positive outcomes. For, sometimes employees become reluctant to use such policies because they believe that benefiting from these practices will obscure their career advancement. Therefore, organizations should encourage the use of family-friendly policies by creating supportive environments and ensure the employees that utilizing them will not result in any penalties.

These findings have also implications for governmental policies. The Article 88 of the Turkish Labor Law No. 4857 dictates that companies, which have more than one hundred and fifty female employees, are obliged to establish nursing homes and childcare centers (Official Gazette, Issue No: 28737, 16/08/2013). However, according to The Corporate Gender Gap Report (Zahidi & Ibarra, 2010), only 21 % of the Turkish organizations provide some form of childcare services to their employees. This is because, as indicated by Aycan and Eskin (2005) and Dedeoğlu (2009), most of the companies in Turkey pay the associated fines instead of offering these facilities to their employees. Increasing the amount of fines in case of violations, on the other hand, may force organizations to adopt family-friendly policies. Similarly, although The Article 5 of the Turkish Labor Law No.4857 (Official Gazette, Issue No: 25134, 10/06/2003) protects employees against any kind of discrimination on the basis of their gender, race, language etc., the incidents of such unfair practices against newly married individuals and/or employees who desire to have children (especially women) during recruitment, promotion, and firing processes are well evident in Turkish business life (see for example, Alparslan, Çetinkaya-Bozkurt, & Özgöz, 2015; Dalkıranoğlu & Çetinel, 2008; Demir, 2011; Doğan, 2012). Indeed, in a study conducted on Turkish tourism

industry (Dalkıranođlu & etinel, 2008) , most of employers reported that they would be more willing to terminate the contract of a pregnant employee in the face of a financial crisis. Therefore, the Turkish Government should also impose severe financial sanctions on organizations that discriminate against married and/or pregnant women in their recruitment and promotion practices. Furthermore, as mentioned before, t-test analyses yielded that women were more likely to experience W-to-FC and suffer from emotional exhaustion than men. If, as speculated, these findings result from the great burden of family responsibilities placed on the shoulders of women, then state-supported training programs, seminars or workshops can be implemented to promote gender equality and equal sharing of domestic responsibilities between women and men.

The path analyses' results revealed that self-determined (autonomous) motivation toward work emerged as a key construct that decreased experiences of work-to-family conflict and increased feelings of job satisfaction. Moreover, it was found to indirectly predict decreased levels of emotional exhaustion (both at work and at home) through its effects on work-to-family conflict, and contributed to the feelings of life satisfaction through its effects on job satisfaction. Considering these positive effects of autonomous motivation, organizations should strive to enhance employees' work motivation. As indicated by the study findings, job characteristics and supportive work environment turned out to be important factors that facilitate autonomous work motivation, presumably by fulfilling employees' basic psychological needs. Designing or enriching jobs so that workers can utilize different skills, exercise freedom and autonomy on the job, obtain accurate feedback regarding their performance, have an opportunity to perform the whole job, and feel that their jobs are meaningful and significant in some respects, will likely to prompt autonomous motivation, increase job satisfaction, decrease the feelings of emotional depletion, and eventually lead to higher levels of life satisfaction. To improve work environment, on the other hand, supervisors can be trained to treat their subordinates in a supportive manner. By this way, supervisors can be encouraged to take employees' perspectives, show concern for their well-being, and help them to solve

their both work and family-related problems. Similarly, training programs may be offered to employees to enhance interpersonal communication and quality of relationships in the work place. Organizations may also intend to establish a culture that emphasize creativity, innovation, self-growth as well as cooperation, harmony, trust and respect among coworkers to facilitate basic need fulfillment.

Like self-determined motivation (autonomous) toward work, self-determined (autonomous) motivation toward family predicted important outcomes of the study. More specifically, it was shown that self-determined motivation toward family was directly associated with reduced family-to-work conflict and increased family satisfaction, and indirectly associated with heightened levels of life satisfaction. These results have implications especially for counsellors and couple-therapists. In the light of aforementioned findings, practitioners who offer help to couples with relationship problems may focus on promoting individuals' autonomous motivation, and emphasize the role of basic need satisfaction in marriage to improve their clients' personal and relationship functioning. Given that perceptions of control at home was a significant predictor of autonomous motivation, as well as of F-to-WC, emotional exhaustion and family satisfaction, therapists may try to increase their clients' sense of control over family-related events and erode their feelings of learned helplessness. Practitioners may, for example, assist their clients in setting more realistic and achievable goals, help them change the way of attributions they make for their successes and failures, aid them to acquire the relevant skills that will lead to desired outcomes, and offer them more adaptive and effective coping strategies to deal with stressful events (Thompson, 1991). As in the case of perceived control, spousal support was found to contribute to autonomous motivation, and be directly associated with reduced emotional exhaustion and increased family satisfaction. Therefore, couple-therapists may desire to focus on increasing partners' supportive behaviors toward each other. By providing support training (Guerney, 1977) or conflict training (Jacobson & Christensen, 1996), relationship counsellors can help couples understand each other's needs, openly discuss their feelings, and respond to their partners' concerns in more constructive rather than defensive manners (Cramer, 2016).

5.4. Limitations and Suggestions for Future Research

Despite its strengths, the current study is not without limitations. A major limitation of the study is its cross-sectional design which does not allow for inferences of causality. Although hypotheses were formulated on the basis of prior research (e.g., Carlson & Kacmar, 2000; Deci & Ryan, 1985, 2000; Frone et al., 1997; Senecal et al., 2001) and the relationships were tested with path analyses, these do not rule out reversed or reciprocal effects. For example, in the present study, it was assumed that individuals, who perceived their jobs as having highly motivating characteristics, would develop more autonomous forms of motivation toward their work, and, eventually, experience elevated levels of job and life satisfaction. Yet, it is equally possible that individuals who were more satisfied with their jobs and lives, and those who displayed greater autonomous motivation toward their work were more likely to perceive their jobs as highly motivating. Indeed, as far as the link between work-family conflict and emotional exhaustion is concerned, there is some evidence of a reciprocal relationship between these constructs. In a longitudinal study conducted with military personnel, Rubio and his colleagues (2015) measured soldiers' perceptions of work-family conflict and their levels of emotional exhaustion at two time points with one-year interval. Results revealed that while work-family conflict assessed in the first year of the study predicted soldiers' emotional exhaustion one year later, emotional exhaustion measured in the first year also predicted soldiers' perceptions of work-family conflict in the second year, creating a loss spiral. Considering these findings, future research may utilize longitudinal, quasi-experimental, or time-lagged designs to more elaborately examine the relationships between work-family conflict and its suggested outcomes.

Another caveat of the study concerns the use of self-report measures which may lead to common method variance and spurious inflations in the associations among the study variables. Future researchers may resort to different sources such as coworkers and/or supervisors for the work domain variables, and spouses and/or relatives for the family domain variables to eliminate single source bias. Moreover, it would be particularly interesting if future studies make appeals to supervisors and

coworkers to rate participants' F-to-WC levels and to spouses and other relatives to rate the participants' W-to-FC levels. For, in the present study, it was maintained that individuals with high autonomous motivation toward work would report less W-to-FC because they would be less likely to perceive their work as interfering with family. However, from the perspective of family members things may be quite different. For them, these individuals may actually experience high levels of W-to-FC because high autonomous (self-determined) motivation toward work may also result in preoccupation and overinvolvement with work. In a similar vein, although participants may believe that they are not experiencing F-to-WC because of their high levels of autonomous motivation toward their families, their co-workers and supervisors may think the opposite, perceiving that these individuals are, in fact, experiencing interferences from the family domain because they are mostly dealing with family issues. Such comparisons of self and others' ratings of WFC may deepen our understanding pertaining to the links between motivational orientations and perceptions of WFC. Additionally, obtaining information from participants' spouses may be especially enlightening when one considers the possibility that strain resulting from the negative experiences at work, including work-to-family conflict, may cross over the partners of the employees, and adversely affect their well-being and relationship satisfaction. In fact, numerous studies in the literature have examined such crossover effects between partners and showed the negative consequences of individuals' work-family conflict experiences for their spouses (Bakker, Demerouti, & Dollard, 2008; Cinamon, Weisel, & Tzuk, 2007; Derya, 2008; Hammer, Allen, & Grigsby, 1997; Kinnunen, Feldt, Mauno, & Rantanen, 2010; Lu, Lu, Du, & Brough, 2016; Westman & Etzion, 2005).

Drawing upon the basic assumptions of Self-Determination Theory (Deci & Ryan, 1985, 2000, 2008), the current study a priori assumed that work-related variables job characteristics and work support, as well as the family-related variables perceived control at home and spousal support would enhance autonomous motivation through basic need satisfaction. Yet, participants' levels of need satisfaction in work and family contexts were not explicitly measured. Future studies

may incorporate need satisfaction scales to further validate the assumptions of SDT. Use of such measures may also be beneficial for examining the relative importance of the three basic needs of autonomy, competence and relatedness in different life arenas. As indicated by La Guardia et al. (2000), fulfillment of the competency need may be especially critical in predicting positive outcomes in work and achievement related domains whereas gratification of relatedness need may be of primary importance for the domains that involve close relationships.

Like most studies in the literature, the current study utilized Netemayer et al.'s (1996) ten-item scale to assess participants' work-family conflict. This scale includes items that reflect time-based and strain-based aspects of W-to-FC and F-to-WC. However, as mentioned in the introduction section, WFC may also occur in a form of behavior-based conflict. Therefore, exclusion of this dimension might have led to under-representation of the construct. More recently, Carlson et al. (2000) have developed a more promising six dimensional measure which involves items tapping all these three forms of conflict in both directions. Since the scale has also been proven to be a reliable and valid measure (Carlson et al., 2000; Lapierre et al., 2008), further studies may use this scale to shed light on the potential sources and consequences of behavioral work-family conflict.

The comprehensive model proposed in the study involved the variables of emotional exhaustion, job satisfaction, family satisfaction and life satisfaction, which have been traditionally considered as the outcomes of work-family conflict. Yet, researchers, who are interested in the topic, may also incorporate the constructs that have been more scarcely studied in the extant literature, such as turnover intentions, absenteeism, parental performance, and quality of child-parent relationship into the study model. Additionally, inclusion of the aforementioned variables into the model may advance our knowledge regarding their possible relationships with motivational orientations, and with the determinants of motivational orientations.

In the present study, it was proposed that the relationships between W-to-FC and family satisfaction, and between F-to-WC and job satisfaction would be moderated by individuals' identification with their work and family roles. As

previously mentioned, although no moderation effect of the identification with the work role was found, identification with the family role was shown to moderate the association between F-to-WC and job satisfaction. Examination of the all the possible moderators that may play a role between these relationships was beyond the scope of this research, however, scholars have introduced other constructs such as coping styles (Aryee et al., 1999; Rantanen, Mauno, Kinnunen, & Rantanen, 2011), gender (Cheung & Wong, 2013), culture (Aycan, 2008; Lu et al., 2010), work/home demands (Demokan, 2009), parental status (Allen et al., 2012), spousal support (Aryee et al., 1999; Chang & Lu, 2011), work support (Huang, 2015), job type (Frone et al., 1992), core self evaluations (Bıçaksız, 2009), self-esteem (Grandey & Cropanzano, 1999) and Big Five personality traits (Kinnunen, Vermulst, Gerris, & Mañkikangas, 2001) as the moderating variables that may either amplify or mitigate the links between WFC, its antecedents and outcomes. Hence, additional research can be conducted to explore what types of moderators are involved in these relationships.

Lastly, the present study dwelled upon the concept of work-family conflict by assuming that adopting multiple roles would create feelings strain and frustration leading to aversive outcomes. However, many researchers (Barnett & Hyde, 2001; Byron, 2005; Carlson, Hunter, Ferguson & Whitten, 2014; Carlson, Kacmar, Wayne, & Grzywacz, 2006; Eby et al., 2005; Frone, 2003; Greenhaus & Parasuraman, 1999; Grzywacz & Bass, 2003; Seery, Corrigan, Harpel, 2008) have pointed out that possessing multiple roles may also positively affect individuals in the sense that skills, experience and knowledge attained in one domain (e.g., work) may make people more easily participate in another role (e.g., family) and handle the demands of this role. Therefore, future researchers are strongly encouraged to recognize these positive aspects of work-family interface and study the concepts such as *work-family facilitation* and *work-family enhancement*. As indicated by Byron (2005) “Research should ...focus on determining the conditions that distinguish when multiple roles lead to distress and when multiple roles lead to increased fulfillment” (p. 193).

REFERENCES

- Acitelli, L. K., & Antonucci, T. C. (1994). Gender differences in the link between marital support and satisfaction in older couples. *Journal of Personality and Social Psychology*, *67*, 688–698.
- Adams, G. A., & Jex, S. M. (1999). Relationships between time management, control, work–family conflict, and strain. *Journal of Occupational Health Psychology*, *4*, 72–77.
- Adams, G. A., King, L. A., & King, D. W. (1996). Relationships of job and family involvement, family social support, and work–family conflict with job and life satisfaction. *Journal of applied psychology*, *81*(4), 411. doi: 10.1037/0021-9010.81.4.411.
- Ahmad, A. (1996). Associations of work-family conflict, job satisfaction, family satisfaction and life satisfaction: A study of married female secretaries. *Pertanika Journal of Social Sciences & Humanities*, *4*(2), 101-108.
- Aiken, L. S., & West, S. G. (1991). *Multiple regression: Testing and interpreting interactions*. Newbury Park, CA: Sage.
- Allen, T. D., Herst, D. E., Bruck, C. S., & Sutton, M. (2000). Consequences associated with work-to-family conflict: a review and agenda for future research. *Journal of occupational health psychology*, *5*(2), 278. doi: 10.1037/1076-8998.5.2.278
- Allen, T. D., Johnson, R. C., Kiburz, K., & Shockley, K. M. (2013). Work-family conflict and flexible work arrangements: Deconstructing flexibility. *Personnel Psychology*, *66*, 345–376.
- Allen, T. D., Johnson, R., Saboe, K., Cho, E., Dumani, S., & Evans, S. (2012). Dispositional variables and work-family conflict: A meta-analysis. *Journal of Vocational Behavior*, *80*, 17-26. doi: 10.1016/j.jvb.2011.04.004.
- Alparslan, A. M., Çetinkaya Bozkurt Ö., Özgöz, A. (2015) “ İşletmelerde Cinsiyet Ayrımcılığı ve Kadın Çalışanların Sorunları”, *MAKÜ İktisadi ve İdari Bilimler Fakültesi Dergisi*, *2*(2), , 66-81.
- Amoura, C., Berjot, S., & Gillet, N. (2013). Desire for control: Its effect on needs satisfaction and autonomous motivation. *International Review of Social Psychology/Revue Internationale de Psychologie Sociale*, *26*(2), 55–71.
- Amoura, C., Berjot, S., Gillet, N., & Altıntaş, E. (2014). Desire for control, perception of control: their impact on autonomous motivation and psychological adjustment. *Motivation and Emotion*, *38*(3), 323-335. doi: 10.1007/s11031-013-9379-9.

- Amstad, F. T., Meier, L. L., Fasel, U., Elfering, A., & Semmer, N. K. (2011). A meta-analysis of work–family conflict and various outcomes with a special emphasis on cross-domain versus matching-domain relations. *Journal of occupational health psychology, 16*(2), 151. doi: 10.1037/a0022170.
- Anderson, R., Manoogian, S. T., & Reznick, J. S. (1976). The undermining and enhancing of intrinsic motivation in preschool children. *Journal of personality and social psychology, 34*(5), 915. doi:10.1037/0022-3514.34.5.915.
- Apaydın, M. D. (2004). *Çift-kariyerli ailelerde iş-aile ve aile-iş çatışmalarının kendini kurgulama düzeyleri ile ilişkisi* (Unpublished master's thesis). , Hacettepe University, Ankara, Turkey.
- Aryee, S. (1992). Antecedents and outcomes of work-family conflict among married professional women: Evidence from Singapore. *Human relations, 45*(8), 813-837. doi: 10.1177/001872679204500804
- Aryee, S., Luk, V., Leung, A., & Lo, S. (1999). Role stressors, interrole conflict, and well-being: The moderating influence of spousal support and coping behaviors among employed parents in Hong Kong. *Journal of Vocational Behavior, 54*(2), 259-278. doi:10.1006/jvbe.1998.1667.
- Aycan, Z. & Balcı, H. (2001). Hizmetiçi eğitiminin etkililiğini yordayan bireysel ve kurumsal faktörler. *Türk Psikoloji Dergisi, 16*(48), 13-31.
- Aycan, Z., & Eskin, M. (2005). Childcare, Spousal, and Organizational Support in Predicting Work-Family Conflict for Females and Males in Dual-Earner Families with Preschool Children. *Sex Roles, 53*(7), 453-471. doi:10.1007/s11199-005-7134-8.
- Baard, P. P., Deci, E. L., & Ryan, R. M. (2004). Intrinsic need satisfaction: A motivational basis of performance and well-being in two work settings. *Journal of Applied Social Psychology, 34*, 2045–2068.
- Baeriswyl, S., Krause, A., & Schwaninger, A. (2016). Emotional Exhaustion and Job Satisfaction in Airport Security Officers–Work–Family Conflict as Mediator in the Job Demands–Resources Model. *Frontiers in psychology, 7*, 663. doi:10.3389/fpsyg.2016.00663
- Bagger, J., Li, A., & Gutek, B. A. (2008). How much do you value your family and does it matter? The joint effects of family identity salience, family-interference-with-work, and gender. *Human Relations, 61*(2), 187-211. doi: 10.1177/0018726707087784.

- Bakker, A. B., & Demerouti, E. (2007). The job demands-resources model: State of the art. *Journal of managerial psychology*, 22(3), 309-328. doi:10.1108/02683940710733115.
- Bakker, A. B., Demerouti, E., & Schaufeli, W. B. (2003). Dual processes at work in a call centre: An application of the job demands–resources model. *European Journal of Work and Organizational Psychology*, 12, 393– 417.
- Bandura, A. (1986). The explanatory and predictive scope of self-efficacy theory. *Journal of social and clinical psychology*, 4(3), 359-373. doi: 10.1521/jscp.1986.4.3.359
- Barrah, J.L., Shultz, K.S., Baltes, B., & Stolz, H.E. (2004). Men’s and women’s elder care based work family conflict: Antecedents and work related outcomes. *Fathering*, 2, 305-330. doi: 10.3149/fth.0203.305.
- Baruch-Feldman, C., Brondolo, E., Ben-Dayana, D., & Schwarz, J. (2002). Sources of social support and burnout, job satisfaction, and productivity. *Journal of Occupational Health Psychology*, 7, 84–93.
- Bass, B. M. (1985). *Leadership and performance beyond expectations*. Free Press; Collier Macmillan.
- Baumeister, R.F., & Leary, M.R. (1995). The need to belong: Desire for interpersonal attachments as a fundamental human motivation. *Psychological Bulletin*, 117, 497-529. doi: 10.1037/0033-2909.117.3.497.
- Behson, S. J., Eddy, E. R., & Lorenzet, S. J. (2000). The importance of the critical psychological states in the job characteristics model: A meta-analytic and structural equations modeling examination. *Current Research in Social Psychology*, 5, 170–189.
- Bentler, P. M., & Wu, E. J. C. 2005. *EQS 6.1 for Windows*. Encino, CA: Multivariate Software.
- Beutell, N. J. (2010). Work schedule, work schedule control and satisfaction in relation to work-family conflict, work-family synergy, and domain satisfaction. *Career Development International*, 15(5), 501-518.
- Beutell, N. J. & Greenhaus, J. H. (1982). Interrole conflict among married women: The influence of husband and wife characteristics on conflict and coping behavior. *Journal of Vocational Behavior*, 21, 99-110.
- Beutell, N. J., & Wittig-Berman, U. (1999). Predictors of work-family conflict and satisfaction with family, job, career, and life. *Psychological Reports*, 85(3), 893-903. doi: 10.2466/pr0.1999.85.3.893

- Bhanji, J. P., Kim, E. S., & Delgado, M. R. (2016). Perceived control alters the effect of acute stress on persistence. *Journal of Experimental Psychology: General*, *145*(3), 356. doi: 10.1037/xge0000137
- Bhowon, U. (2013). Role salience, work-family conflict and satisfaction of dual-earner couples. *Journal of Business Studies Quarterly*, *5*(2), 78.
- Bıçaksız, P. (2009). *The effects of gender role ideology, role salience, role demands and core self-evaluations on work-family interface* (Unpublished master's thesis). Middle East Technical University, Ankara, Turkey.
- Bilgiç, R. (2008). İş özellikleri kuramı: Geniş kapsamlı gözden geçirme. *Türk Psikoloji Yazıları*, *11*(22), 66-77.
- Black, A. E., & Deci, E. L. (2000). The effects of instructors' autonomy support and students' autonomous motivation on learning organic chemistry: A self-determination theory perspective. *Science education*, *84*(6), 740-756. doi: 10.1002/1098-237X(200011)84:6<740::AID-SCE4>3.0.CO;2-3.
- Blais, R., Lachance, L., Vallerand, J., Briere, M., & Riddle, S. (1993). L'inventaire des motivations au travail. *Revue Québécoise de Psychologie*, *14*(3), 21-23.
- Blanch, A., & Aluja, A. (2012). Social support (family and supervisor), work-family conflict, and burnout: Sex differences. *Human Relations*, *65*(7), 811-833. doi: 10.1177/0018726712440471.
- Boggiano, A. K., Main, D. S., & Katz, P. A. (1988). Children's preference for challenge: The role of perceived competence and control. *Journal of Personality and Social Psychology*, *54*, 134-141.
- Boonzaier, B., Ficker, B., & Rust, B. (2001). A review of research on the Job Characteristics Model and the attendant job diagnostic survey. *South African journal of business management*, *32*(1), 11-34.
- Bouchard, G., Lee, C. M., Asgary, V., & Pelletier, L. (2007). Fathers' motivation for involvement with their children: A self-determination theory perspective. *Fathering*, *5*(1), 25-41.
- Boyar, S. L., Carson, C. M., Mosley Jr, D. C., Maertz Jr, C. P., & Pearson, A. W. (2006). Assessment of the validity of Netemeyer et al.'s (1996) WFC and FWC scales. *International Journal of Conflict Management*, *17*(1), 34-44. doi: 10.1108/10444060610734163.
- Böyüksoğak, A. (2016). *Testing predictions from self determination theory using programme for international student assessment (Pisa) 2012 data for mathematics learning*. (Unpublished master's thesis). Boğaziçi University, İstanbul, Turkey.

- Brief, A. P., & Aldag, R. J. (1975). Employee reactions to job characteristics: A constructive replication. *Journal of Applied Psychology*, *60*(2), 182. doi: 10.1037/h0076548.
- Bruck, C. S., Allen, T. D., & Spector, P. E. (2002). The relation between work–family conflict and job satisfaction: A finer-grained analysis. *Journal of vocational behavior*, *60*(3), 336-353. doi:10.1006/jvbe.2001.1836.
- Bullers, S., & Prescott, C. A. (2001). An exploration of the independent contributions of genetics, shared environment, specific environment, and adult roles and statuses on perceived control. *Sociological inquiry*, *71*(2), 145-163. doi: 10.1111/j.1475-682X.2001.tb01106.x
- Burger, J. M. (1989). Negative reactions to increases in perceived personal control. *Journal of personality and social psychology*, *56*(2), 246. doi: 10.1037/0022-3514.56.2.246
- Burke, R. J. (1988). Some antecedents of work-family conflict. *Journal of Social Behavior and personality*, *3*(4), 287.
- Burke R.J. & Greenglass E.R. (2001) Hospital restructuring, work-family conflict and psychological burnout among nursing staff. *Psychology and Health*, *16*, 583–594.
- Burke, R. J., Greenglass, E. R., & Schwarzer, R. (1996). Predicting teacher burnout over time: Effects of work stress, social support, and self-doubts on burnout and its consequences. *Anxiety, Stress, and Coping*, *9*, 261–275.
- Burke, P. J., & Reitzes, D. C. (1981). The link between identity and role performance. *Social psychology quarterly*, 83-92. doi: 10.2307/3033704
- Burke, R.J., Weir, T., & DuWors, R.E. (1980). Work demands on administrators and spouse well-being. *Human Relations*, *33*(4), 253-278. doi: 10.1177/001872678003300404.
- Byron, D. (2005). A meta-analytic review of work-family conflict and its antecedents. *Journal of Vocational Behavior*, *67*, 169-198. doi:10.1016/j.jvb.2004.08.009.
- Camp, P. L., & Ganong, L. H. (1997). Locus of control and marital satisfaction in long-term marriages. *Families in Society*, *78*, 624-631.
- Carlson, D. S., Grzywacz, J. G., & Kacmar, K. M. 2010. The relationship of schedule flexibility and outcomes via the work–family interface. *Journal of Managerial Psychology*, *25*, 330-355. doi: 10.1108/02683941011035278.

- Carlson, D. S., & Kacmar, K. M. (2000). Work–family conflict in the organization: Do life role values make a difference?. *Journal of Management*, 26(5), 1031-1054. doi: 10.1177/014920630002600502.
- Carlson, D. S., Kacmar, K. M., & Williams, L. J. (2000). Construction and initial validation of a multidimensional measure of work–family conflict. *Journal of Vocational behavior*, 56(2), 249-276. doi:10.1006/jvbe.1999.1713.
- Carlson, D. S., & Perrewe, P. L. (1999). The role of social support in the stressor–strain relationship: *An examination of work–family conflict*. *Journal of Management*, 25, 513–540.
- Carr, J. C., Boyar, S. L., & Gregory, B. T. (2008). The moderating effect of work—family centrality on work—family conflict, organizational attitudes, and turnover behavior. *Journal of Management*, 34(2), 244-262. doi: 10.1177/0149206307309262.
- Chemolli, E., & Gagné, M. (2014). Evidence against the continuum structure underlying motivation measures derived from self-determination theory. *Psychological Assessment*, 26, 575–585. doi:10.1037/a0036212
- Chen, K. C., & Jang, S. J. (2010). Motivation in online learning: testing a model of self-determination theory. *Computers in Human Behavior*, 26(4), 741–752.
- Chirkov, V. I., Ryan, R. M., & Willness, C. (2005). Cultural context and psychological needs in Canada and Brazil: Testing a self-determination approach to the internalization of cultural practices, identity, and well-being. *Journal of Cross-Cultural Psychology*, 36, 423-443. doi: 10.1177/0022022105275960.
- Chirkov, V. I., Vansteenkiste, M., Tao, R., & Lynch, M. (2007). The role of self-determined motivation and goals for study abroad in the adaptation of international students. *International Journal of Intercultural Relations*, 31, 199-222.
- Cinamon, R. G., Weisel, A., & Tzuk, K. (2007). Work—Family Conflict Within the Family Crossover Effects, Perceived Parent—Child Interaction Quality, Parental Self-Efficacy, and Life Role Attributions. *Journal of Career Development*, 34(1), 79-100. doi: 10.1177/0894845307304066.
- Cohen, S., & Wills, T. A. (1985). Stress, social support, and the buffering hypothesis. *Psychological bulletin*, 98(2), 310. doi: 10.1037/0033-2909.98.2.310.
- Cokley, K. (2000). An Investigation of academic self-concept and its relationship to academic achievement in African American college students. *Journal of Black Psychology*, 26(2), 148-164.

- Coşkun, H. (2012). *The examination of the moderating role of personality trait on the relationship between job characteristics, boredom at work and intention to leave* (Unpublished master's thesis). Marmara Üniversitesi, İstanbul, Turkey.
- Cramer, S. A. (2016). *Acting With Faith: Acceptance And Commitment Therapy For Interfaith Couples*. (Unpublished doctoral dissertation). Widener University, Chester, U.S.A.
- Cutrona, C. E., & Suhr, J. A. (1994). Social support communication in the context of marriage: An analysis of couples' supportive interactions. In B. Burleson, T. Albrecht, & I. Sarason (Eds.), *Communication of social support: Messages, relationships, and community* (pp. 113–133). Thousand Oaks, CA: Sage.
- Çapri, B. (2006). Tükenmişlik Ölçeğinin Türkçe Uyarlaması: Geçerlik ve Güvenirlik Çalışması. *Mersin Üniversitesi Eğitim Fakültesi Dergisi*, 2(1), 62-77.
- Çenesiz, G.(2015). *The Relationship Between Eating Attitudes, Personality Factors, Weight Perception, Self-Esteem, Appearance Esteem, And Eating Regulation Motivations Based On Self Determination Theory* (Unpublished doctoral dissertation)., Middle East Technical University, Ankara, Turkey.
- d'Ailly, H. (2003). Children's autonomy and perceived control in learning: A model of motivation and achievement in Taiwan. *Journal of Educational Psychology*, 95(1), 84. doi: 10.1037/0022-0663.95.1.84.
- Dalkıranoglu, T., & Çetinel, F. (2008). Konaklama İşletmelerinde Kadın ve Erkek Yöneticilerin Cinsiyet Ayrımcılığına Karşı Tutumlarının Karşılaştırılması. *Dumlupınar Üniversitesi Sosyal Bilimler Dergisi*, 20, .77-296.
- Day, A. L., & Chamberlain, T. C. (2006). Committing to your work, spouse, and children: Implications for work–family conflict. *Journal of Vocational Behavior*, 68(1), 116-130. doi: 10.1016/j.jvb.2005.01.001
- De Bilde, J., Vansteenkiste, M., & Lens, W. (2011). Understanding the association between future time perspective and self-regulated learning through the lens of self-determination theory. *Learning and Instruction*, 21, 332-344. doi:10.1016/j.learninstruc.2010.03.002
- De Cooman, R., Stynen, D., Van den Broeck, A., Sels, L., & De Witte, H. (2013). How job characteristics relate to need satisfaction and autonomous motivation: Implications for work effort. *Journal of Applied Social Psychology*, 43(6), 1342-1352. doi:10.1111/jasp.12143.
- De Jong, R. D., Van Der Velde, M. E., & Jansen, P. G. (2001). Openness to experience and growth need strength as moderators between job characteristics and satisfaction. *International Journal of Selection and Assessment*, 9(4), 350-356. doi:10.1111/1468-2389.00186

- De Rijk, A. E., Le Blanc, P. M., Schaufeli, W. B., & De Jonge, J. (1998). Active coping and need for control as moderators of the job demand– control model: Effects on burnout. *Journal of Occupational and Organizational Psychology*, *71*, 1–18.
- DeCharms, R. (1968). *Personal causation: The internal affective determinants of behavior*. New York: Academic Press. doi: 10.1111/j.1559-1816.1972.tb01266.x.
- Deci, E. L. (1971). Effects of externally mediated rewards on intrinsic motivation. *Journal of Personality and Social Psychology*, *18*(1), 105. doi:10.1037/h0030644.
- Deci, E. L., Connell, J. P., & Ryan, R. M. (1989). Self-determination in a work organization. *Journal of Applied Psychology*, *74*, 580–590. doi:10.1037/0021-9010.74.4.580.
- Deci, E. L., & Ryan, R. M. (1985). *Intrinsic motivation and self-determination in human behavior*. New York: Plenum Press. doi:10.1016/0092-6566(85)90023-6.
- Deci, E. L., & Ryan, R. M. (2000). The 'what' and 'why' of goal pursuits: Human needs and the self-determination of behavior. *Psychological Inquiry*, *11*, 227–268. doi: 10.1207/S15327965PLI1104_01.
- Deci, E. L., & Ryan, R. M. (2002). *Handbook of self-determination research*. University Rochester Press.
- Deci, E. L., & Ryan, R. M. (2008). Facilitating optimal motivation and psychological well-being across life's domains. *Canadian Psychology*, *49*, 14–23. doi: 10.1037/0708-5591.49.1.14.
- Deci, E. L., Ryan, R. M., Gagne', M., Leone, D. R., Usunov, J., & Kornazheva, B. P. (2001). Need satisfaction, motivation, and well-being in the work organizations of a former Eastern Bloc country. *Personality and Social Psychology Bulletin*, *27*, 930–942.
- Dehle, C., Larsen, D., & Landers, J. E. (2001). Social support in marriage. *American Journal of Family Therapy*, *29*, 307–324.
- Demerouti E., Mostert K., & Bakker A.B. (2010). Burnout and work engagement: a thorough investigation of the independency of both constructs. *Journal of Occupational Health Psychology*, *15*, 209–220.
- Demir, M. (2011). İş Yaşamında Ayrımcılık: Turizm Sektörü Örneği. *Uluslararası İnsan Bilimleri Dergisi*, *1*, 760 – 784.

- Demokan, A. (2009). *The influence of social support, perceived control, locus of control and job/home demands on coping with work-family conflict* (Unpublished master's thesis). Middle East Technical University, Ankara, Turkey.
- Derya, S. (2008). *Crossover of work-family conflict: Antecedent and consequences of crossover process in dual-earner couples*. (Unpublished master's thesis). Koc University, Istanbul, Turkey.
- Desrochers, S., Andreassi, J., & Thompson, C. (2004). Identity Theory. *Organization Management Journal*, 1(1), 61-69. doi: 10.1057/omj.2004.14
- Diener, E., Emmons, R. A., Larsen, R. J., & Griffin, S. (1985). The satisfaction with life scale. *Journal of Personality Assessment*, 49(1), 71–75.
- Dodd, N. G. & Gangster, D.C. (1996). The interactive effects of variety, autonomy, and feedback on attitudes and performance. *Journal of Organizational Behavior*, 17 (4), 329-347.
- Doğan, E. T. (2012). Hamile Kadınların Çalışma Yaşamında Maruz Kaldığı Ayrımcı Uygulamalar. *İş Güç Endüstri İlişkileri ve İnsan Kaynakları Dergisi*, 14(2), 79–98.
- Dugan, A., Matthews, R. A., & Barnes-Farrell, J. L. (2012). Understanding the role of subjective and objective experiences of time in the work-family interface. *Community, Work & Family*, 15(2), 149-172. doi:10.1080/13668803.2011.609656.
- Duxbury, L. E., Higgins, C., & Lee, C (1994). Work-family conflict: A comparison by gender, family type, and perceived control. *Journal of Family Issues*, 15, 449-466.
- Eby, L. T., Casper, W. J., Lockwood, A., Bordeaux, C., & Brinley, A. (2005). Work and family research in IO/OB: Content analysis and review of the literature (1980–2002). *Journal of vocational behavior*, 66(1), 124-197. doi: 10.1016/j.jvb.2003.11.003.
- Eisenberger, R., Cummings, J., Armeli, S., & Lynch, P. (1997). Perceived organizational support, discretionary treatment, and job satisfaction. *Journal of Applied Psychology*, 82, 812–820.
- Ergin C. (1992). Doktor ve hemşirelerde tükenmişlik ve Maslach Tükenmişlik Ölçeği'nin uyarlanması. *7.Ulusal Psikoloji Kongresi Bilimsel Çalışmaları*, 143-154.
- Farmer, S. M., Tierney, P., & Kung-McIntyre, K. (2003). Employee creativity in Taiwan: An application of role identity theory. *Academy of Management Journal*, 46(5), 618-630. doi: 10.2307/30040653

- Feeney, B. C. (2004). A secure base: responsive support of goal strivings and exploration in adult intimate relationships. *Journal of personality and social psychology*, 87(5), 631. doi: 10.1037/0022-3514.87.5.631.
- Fernet, C., Austin, S., Trépanier, S. G., & Dussault, M. (2013). How do job characteristics contribute to burnout? Exploring the distinct mediating roles of perceived autonomy, competence, and relatedness. *European Journal of Work and Organizational Psychology*, 22(2), 123-137. doi:10.1080/1359432X.2011.632161.
- Fernet, C., Gagné, M., & Austin, S. (2010). When does quality of relationships with coworkers predict burnout over time? The moderating role of work motivation. *Journal of Organizational Behavior*, 31(8), 1163-1180. doi:10.1002/job.673.
- Fernet, C., Guay, F., Senécal, C., & Austin, S. (2012). Predicting intraindividual changes in teacher burnout: The role of perceived school environment and motivational factors. *Teaching and Teacher Education*, 28(4), 514-525. doi:10.1016/j.tate.2011.11.013.
- Fernet, C., Senécal, C., Guay, F., Marsh, H., & Dowson, M. (2008). The Work Tasks Motivation Scale for Teachers (WTMST). *Journal of Career Assessment*, 16, 256-279.
- Firth, N., Frydenberg, E., & Greaves, D. (2008). Perceived control and adaptive coping: Programs for adolescent students who have learning disabilities. *Learning Disability Quarterly*, 31(3), 151-165.
- Fletcher, B. C., & Jones, F. (1993). A refutation of Karasek's demand-discretion model of occupational stress with a range of dependent measures. *Journal of Organizational Behavior*, 14, 319-330
- Ford, M., Heinen, B., & Langkamer, K. (2007). Work and family satisfaction and conflict: A meta-analysis of cross-domain relations. *Journal of Applied Psychology*, 92, 57-80. doi: 10.1037/0021-9010.92.1.57.
- Frese, M. (1999). Social support as a moderator of the relationship between work stressors and psychological dysfunctioning: a longitudinal study with objective measures. *Journal of occupational health psychology*, 4(3), 179. doi:10.1037/1076-8998.4.3.179/
- Fried, Y., & Ferris, G. R. (1987). The validity of the job characteristics model: A review and meta-analysis. *Personnel psychology*, 40(2), 287-322. doi:10.1111/j.1744-6570.1987.tb00605.x.
- Frone, M. R. (2000). Work-family conflict and employee psychiatric disorders: The national comorbidity survey. *Journal of Applied psychology*, 85(6), 888. doi.org/10.1037/0021-9010.85.6.888.

- Frone, M. R., & Rice, R. W. (1987). Work-family conflict: the effect of job and family involvement. *Journal of Organizational Behavior*, 8(1), 45-53. doi:10.1002/job.4030080106
- Frone, M. R., Russell, M., & Barnes, G. M. (1996). Work-family conflict, gender, and health-related outcomes: A study of employed parents in two community samples. *Journal of occupational health psychology*, 1(1), 57. doi.org/10.1037/1076-8998.1.1.57.
- Frone, M. R., Russell, M., & Cooper, M. L. (1992). Prevalence of work-family conflict: Are work and family boundaries asymmetrically permeable? *Journal of Organizational Behavior*, 13, 723-729. doi: 10.1002/job.4030130708.
- Frone, M. R., Yardley, J., & Markel, K. S. (1997). Developing and testing an integrative model of the work-family interface. *Journal of Vocational Behavior*, 50, 145-167. doi:10.1006/jvbe.1996.1577.
- Frye, N. K., & Breugh, J. A. (2004). Family-friendly policies, supervisor support, work-family conflict, family-work conflict, and satisfaction: A test of a conceptual model. *Journal of Business and Psychology*, 19(2), 197-220. doi: 10.1007/s10869-004-0548-4
- Fusilier, M. R., Ganster, D. C., & Mayes, B. T. (1987). Effects of social support, role stress, and locus of control on health. *Journal of Management*, 13(3), 517-528. doi: 10.1177/014920638701300308.
- Gagne', M., & Deci, E. L. (2005). Self-determination theory as a new framework for understanding organizational behavior. *Journal of Organizational Behavior*, 26, 331-362. doi: 10.1002/job.322.
- Gagne, M., Forest, J., Gilbert, M.-H., Aube, C., Morin, E., & Malorni, A. (2010). The motivation at work scale: Validation evidence in two languages. *Educational and Psychological Measurement*, 70, 628-646.
- Gagne, M., Forest, J., Vansteenkiste, M., Crevier-Braud, L., Van Den Broeck, A., Aspeli, A. et al. (2015). The multidimensional work motivation scale: Validation evidence in seven languages and nine countries. *European Journal of Work and Organizational Psychology*, 24, 178-196.
- Gagne', M., Sene'cal, C., & Koestner, R. (1997). Proximal job characteristics, feelings of empowerment, and intrinsic motivation: A J model. *Journal of Applied Social Psychology*, 27, 1222-1240. doi: 10.1111/j.1559-1816.1997.tb01803.x.
- Gaine, G. S., & La Guardia, J. G. (2009). The unique contributions of motivations to maintain a relationship and motivations toward relational activities to relationship well-being. *Motivation and Emotion*, 33, 184-202. doi:10.1007/s11031-009-9120-x

- Gallagher, M. W., Bentley, K. H., & Barlow, D. H. (2014). Perceived control and vulnerability to anxiety disorders: A meta-analytic review. *Cognitive Therapy and Research, 38*(6), 571-584.
- Gillet, N., Fouquereau, E., Lafreniere, M. A. K., & Huyghebaert, T. (2016). Examining the Roles of Work Autonomous and Controlled Motivations on Satisfaction and Anxiety as a Function of Role Ambiguity. *Journal of Psychology, 150*(5), 644-665. doi:10.1080/00223980.2016.1154811
- Giray, M. D. & Ergin, C. (2006). Çift-Kariyerli Ailelerde Bireylerin Yaşadıkları İş-Aile ve Aile-İş Çatışmalarının Kendini Kurgulama Davranışı ve Yaşam Olayları ile İlişkisi. *Türk Psikoloji Dergisi, 21*, 83-101.
- Grandey, A. A., & Cropanzano, R. (1999). The conservation of resources model applied to work–family conflict and strain. *Journal of vocational behavior, 54*(2), 350-370. doi:10.1006/jvbe.1998.1666.
- Grandey, A., Cordeiro, B., & Crouter, A. (2005). A longitudinal and multi-source test of the work–family conflict and job satisfaction relationship. *Journal of occupational and Organizational Psychology, 78*(3), 305-323. doi: 10.1348/096317905X26769
- Grant, A. M., & Berry, J. W. (2011). The Necessity of Others is the Mother of Invention: Intrinsic and Prosocial Motivations, Perspective Taking, and Creativity. *Academy of Management Journal, 54*(1), 73-96.
- Graves, L. M., & Luciano, M. M. (2013). Self-determination at work: Understanding the role of leader-member exchange. *Motivation and Emotion, 37*, 518–536.
- Greenhaus, J. H., & Beutell, N. J. (1985). Sources of conflict between work and family roles. *Academy of Management Review, 10*(1), 76–88. doi: 10.2307/258214.
- Greenhaus, J. H., & Kopelman, R. E. (1981). Conflict between work and nonwork roles: Implications for the career planning process. *Human Resource Planning, 4*(1), 1-10.
- Greenhaus, J. H., Parasuraman, S., & Collins, K. M. (2001). Career involvement and family involvement as moderators of relationships between work–family conflict and withdrawal from a profession. *Journal of occupational health psychology, 6*(2), 91. doi: 10.1037/1076-8998.6.2.91
- Greenhaus, J. H., Parasuraman, S., Granrose, C. S., Rabinowitz, S., & Beutell, N. J. (1989). Sources of work–family conflict among two career couples. *Journal of Vocational Behavior, 34*, 133–153.
- Greiff, B. S. & Munter, P. K. (1980). *Tradeoffs: Executive, Family, and Organizational Life. Mentor Executive Library*, New York.

- Griffin, M.L., Hogan, N.L. and Lambert, E.G. (2012). Doing “people work” in the prison setting: an examination of the job characteristics model and correctional staff burnout. *Criminal Justice and Behavior*, 39 (9), 1131-1147.
- Griffin M.A., Patterson M.G. & West M.A. (2001) Job satisfaction and teamwork. *Journal of Organisational Behaviour* ,22, 537–550.
- Grzywacz, J. G., Arcury, T. A., Ma´rin, A., Carrillo, L., Burke, B., & Coates, M. L., ... Quandt, S. A. (2007). Work-family conflict: Experiences and health implications among immigrant Latinos. *Journal of Applied Psychology*, 92, 1119–1130.
- Gözükara, İ., & Çolakoğlu, N. (2015). The impact of manager support and work family conflict on job satisfaction. *Business Management Dynamics*, 5(6), 13–25.
- Guay, F., Ratelle, C. F., Roy, A., & Litalien, D. (2010). Academic self-concept, autonomous academic motivation, and academic achievement: Mediating and additive effects. *Learning and Individual Differences*, 20(6), 644-653. doi: 10.1016/j.lindif.2010.08.001.
- Guemey, B. G. Jr. (1977). *Relationship enhancement skill training programs for therapy, prevention and enrichment*. San Francisco: Jossey-Bass.
- Gutek, B. A., Searle, S., & Klepa, L. (1991). Rational versus gender role explanations for work-family conflict. *Journal of applied psychology*, 76(4), 560. doi: 10.1037/0021-9010.76.4.560.
- Güntert, S. T. (2015). The impact of work design, autonomy support, and strategy on employee outcomes: A differentiated perspective on self-determination at work. *Motivation and Emotion*, 39(1), 74-87.
- Haar, J., Russo, M., Sune, A., & Ollier-Malaterre, A. (2014). Outcomes of work ~ elife balance on job satisfaction, life satisfaction and mental health: a study across seven cultures. *Journal of Vocational Behavior*, 85(3), 361-373.
- Hackman, J. R., & Lawler, E. E. (1971). Employee reactions to job characteristics. *Journal of applied psychology*, 55(3), 259. doi:10.1037/h0031152.
- Hackman, J. R., & Oldham, G. R. (1976). Motivation through the design of work: Test of a theory. *Organizational Behavior and Human Performance*, 16, 250–279. doi:10.1016/0030-5073(76)90016-7.
- Hackman, J. R., & Oldham, G. R. (1980). *Work redesign*. Reading, MA: Addison-Wesley.

- Hadden, B. W., Rodriguez, L. M., Knee, C. R., & Porter, B. (2015). Relationship autonomy and support provision in romantic relationships. *Motivation and Emotion, 39*(3), 359-373. doi: 10.1007/s11031-014-9455-9.
- Hadden, B. W., Smith C.V., & Knee, C. R. (2014). The way I make you feel: how relatedness and compassionate goals promote partner's relationship satisfaction. *Journal of Positive Psychology, 9*, 155–62.
- Haines, V. Y., Harvey, S., Durand, P., & Marchand, A. (2013). Core Self-Evaluations, Work–Family Conflict, and Burnout. *Journal of Marriage and Family, 75*(3), 778-793. doi: 10.1111/jomf.12026.
- Halbesleben, J. R. B. (2006). Sources of social support and burnout: A meta-analytic test of the conservation of resources model. *Journal of Applied Psychology, 91*, 1134–1145. doi:10.1037/0021-9010.91.5.1134
- Halbesleben, J. R. B., Zellars, K., Carlson, D. C., Perrewe, P. L., & Rotondo, D. (2010). Moderating effect of worklinked couple relationships and work-family integration on the spouse instrumental support-emotional exhaustion relationship. *Journal of Occupational Health Psychology, 15*, 371-387.
- Halbesleben, J. R. B., Wheeler, A. R., & Rossi, A. M. (2012). The costs and benefits of working with one's spouse: A two-sample examination of spousal support, work-family conflict, and emotional exhaustion in work-linked relationships. *Journal of Organizational Behavior, 33*, 597-615.
- Hall, D., & Gordon, F. (1973). Career choices of married women: Effects on conflict, role behavior and satisfaction. *Journal of Applied Psychology, 58*(1) 42–48. doi: 10.1037/h0035404.
- Halvari A. E. M., Halvari H., Bjørnebekk G., & Deci E. L. (2010). Motivation and anxiety for dental treatment: Testing a self-determination theory model of oral self-care behaviour and dental clinic attendance. *Motivation and Emotion, 34*, 15–33. doi:10.1007/s11031-010-9154-010.1007/s11031-010-9154-0
- Harter, S., (1983). Developmental perspectives on the self-system. In E. M. Heatherington (Ed.), *Handbook of child psychology: Socialization, personality and social development* (Vol. 4, pp. 275-386). New York: Wiley.
- Hartmann, C., Dohle, S., & Siegrist, M. (2015). A self-determination theory approach to adults' healthy body weight motivation: A longitudinal study focussing on food choices and recreational physical activity. *Psychology & health, 30*(8), 924-948. doi: 10.1080/08870446.2015.1006223.

- Haüsser, J., Mojzisch, A., Niesel, M., & Schulz-Hardt, S. (2010). Ten years on: A review of recent research on the Job Demand–Control (–Support) Model and psychological well-being. *Work and Stress, 24*, 1–35. doi:10.1080/02678371003683747.
- Hayamizu, T. (1997). Between intrinsic and extrinsic motivation: Examination of reasons for academic study based on the theory of internalization. *Japanese Psychological Research, 39* (2), 98-108. doi: 10.1111/1468-5884.00043.
- Hayes, A. F. (2013). *An introduction to mediation, moderation, and conditional process analysis*. New York: The Guilford Press.
- Hetland, H., Hetland, J., Andreassen, C. S., Pallesen, S., & Notelaers, G. (2011). Leadership and fulfillment of the three basic psychological needs at work. *Career Development International, 16* (5), 507-523. <http://dx.doi.org/10.1108/13620431111168903>
- Hofstede, G. (1991). Empirical models of cultural differences. In N. Bleichrodt & P. J. D. Drenth (Eds.), *Contemporary issues in cross-cultural psychology* (pp. 4-20). Lisse, the Netherlands: Swets & Zeitlinger.
- Hogg, M. A., Terry, D. J., & White, K. M. (1995). A tale of two theories: A critical comparison of identity theory with social identity theory. *Social psychology quarterly, 255-269*. doi: 10.2307/2787127
- Hortop, E. G., Wrosch, C., & Gagné, M. (2013). The why and how of goal pursuits: Effects of global autonomous motivation and perceived control on emotional well-being. *Motivation and Emotion, 37*(4), 675-687. doi:10.1007/s11031-013-9349-2
- Houkes, I., Janssen, P. P., de Jonge, J., & Nijhuis, F. J. (2001). Specific relationships between work characteristics and intrinsic work motivation, burnout and turnover intention: A multi-sample analysis. *European Journal of Work and Organizational Psychology, 10*(1), 1-23. doi: 10.1080/13594320042000007.
- Hsieh, H. H., & Huang, J.T. (2017). Core Self-Evaluations and Job and Life Satisfaction: The Mediating and Moderated Mediating Role of Job Insecurity. *The Journal of Psychology, 151* (3), 282-298.
- Hsu, Y. R. (2011). Work-family conflict and job satisfaction in stressful working environments: The moderating roles of perceived supervisor support and internal locus of control. *International Journal of Manpower, 32*(2), 233-248.
- Humphrey, S. E., Nahrgang, J. D., & Morgeson, F. P. (2007). Integrating motivational, social, and contextual work design features: a meta-analytic summary and theoretical extension of the work design literature. *Journal of Applied Psychology, 92*(5), 1332. doi:10.1037/0021-9010.92.5.1332.

- Jacelon, C. S. (2007). Theoretical perspectives of perceived control in older adults: A selective review of the literature. *Journal of advanced nursing*, 59(1), 1-10. doi:10.1111/j.1365-2648.2007.04320.x
- Jacobson, N. S., & Christensen, A. (1996). *Integrative couple therapy: Promoting acceptance and change*. New York: Norton.
- Jansen, P. G. M., Kerkstra, A., Abu-Saad, H. H., & van der Zee, J. (1996). The effects of job characteristics and individual characteristics on job satisfaction and burnout in community nursing. *International Journal of Nursing Studies*, 33, 407-421.
- Johnson, J. V., & Hall, E. M. (1988). Job strain, work place social support, and cardiovascular disease: a cross-sectional study of a random sample of the Swedish working population. *American journal of public health*, 78(10), 1336-1342. doi:10.2105/AJPH.78.10.1336.
- Jones, A.P., and Butler, M.C. (1980). A role transition approach to the stresses of organizationally induced family role disruption. *Journal of Marriage and the Family*, 42, 367-376. doi: 10.2307/351234.
- Judge, T. A., Bono, J. E., & Locke, E. A. (2000). Personality and job satisfaction: the mediating role of job characteristics. *Journal of applied psychology*, 85(2), 237. doi:10.1037/0021-9010.85.2.237.
- Judge, T.A, Ilies, R., & Scott (2006). Work family conflict and emotions: effects at work and at home. *Personnel Psychology*, 59, 779-814. doi:10.1111/j.1744-6570.2006.00054.x.
- Julien, D., & Markman, H. J. (1991). Social support and social networks as determinants of individual and marital outcomes. *Journal of Social and Personal Relationships*, 8, 549-568.
- Jonge, J. de, & Landeweerd, J. A. (1993). Toetsing van de Job Demand-Control benadering bij werknemers in de gezondheidszorg: Een secundaire data-analyse [Testing the Job DemandControl approach among health care workers: A secondary analysis]. *Cedrag en Organisatie*, 6(2), 79-92.
- Kabasakal, H., & Bodur, M. (2002). Arabic cluster: a bridge between East and West, *Journal of World Business* 37, 40-54.
- Kale, E. (2015). Lider desteği ve iş arkadaşları desteğinin iş performansı üzerine etkileri: iş tatmini ve yaşam tatmininin aracı rolü. *Uluslararası İktisadi ve İdari İncelemeler Dergisi*, 14, 103-120.
- Kanungo, R. N. (1982). Measurement of job and work involvement. *Journal of Applied Psychology*, 67(3), 341-349

- Karasek Jr., R.A. (1979). Job demands, job decision latitude and mental strain: implications for job redesign. *Administrative Science Quarterly* 24, 285-307.
- Karasek, R. A., Brisson, C., Kawakami, N., Houtman, I., & Bongers, P. (1998). The Job Content Questionnaire (JCQ): an instrument for internationally comparative assessments of psychosocial job characteristics. *Journal of Occupational Health Psychology*, 3, 322–355.
- Karatepe, O. M., & Tekinkus, M. (2006). The effects of work-family conflict, emotional exhaustion, and intrinsic motivation on job outcomes of front-line employees. *International Journal of Bank Marketing*, 24(3), 173-193. doi: 10.1108/02652320610659021
- Kelloway, E. K., & Barling, J. (1991). Job characteristics, role stress and mental health. *Journal of Occupational Psychology*, 64, 291–304.
- Kelloway, E. K., Gottlieb, B. H., & Barham, L. (1999). The source, nature, and direction of work and family conflict: a longitudinal investigation. *Journal of occupational health psychology*, 4(4), 337. doi: 10.1037/1076-8998.4.4.337.
- Kındap, Y. (2011). *Kendini Belirleme Kuramı temelinde ergenlikte destekleyici ebeveynlik, akademik ve sosyal uyum ve kendini belirleme düzeyi arasındaki ilişkilerin boylamsal olarak incelenmesi*. (Unpublished doctoral dissertation). Hacettepe Üniversitesi, Ankara, Turkey.
- Kinnunen, U., & Mauno, S. (1998). Antecedents and outcomes of work-family conflict among employed women and men in Finland. *Human Relations*, 51(2), 157-177. doi: 10.1177/001872679805100203.
- Klein, C. T., & Helweg-Larsen, M. (2002). Perceived control and the optimistic bias: A meta-analytic review. *Psychology and Health*, 17(4), 437-446. doi:10.1080/0887044022000004920
- Knee, C. R., Patrick, H., Vietor, N. A., Nanayakkara, A., & Neighbors, C. (2002). Self-determination as growth motivation in romantic relationships. *Personality and Social Psychology Bulletin*, 28, 609 – 619.
- Koekemoer, F. E., & Mostert, K. (2006). Job characteristics, burnout and negative workhome interference in a nursing environment. *SA Journal of Industrial Psychology*, 32(3), 79-86. doi: 10.4102/sajip.v32i3.441
- Kossek, E. E., & Ozeki, C. (1998). Work–family conflict, policies, and the job–life satisfaction relationship: A review and directions for organizational behavior–human resources research. *Journal of Applied Psychology*, 83, 139–149. doi: 10.1037/0021-9010.83.2.139.

- Kovjanic, S., Schuh, S. C., Jonas, K., Quaquebeke, N. V., & Dick, R. (2012). How do transformational leaders foster positive employee outcomes? A self-determination-based analysis of employees' needs as mediating links. *Journal of Organizational Behavior*, 33(8), 1031-1052. doi: 10.1002/job.1771.
- Köker, S. (1991). *Normal ve Sorunlu Ergenlerin Yaşam Doyumu Düzeylerinin Karşılaştırılması* (Unpublished master's thesis). Ankara University, Ankara, Turkey.
- Köseoğlu, Y. (2013). Academic motivation of the first-year university students and the self-determination theory. *Educational Research and Reviews*, 8(8), 418-424.
- Kula, S., & Güler, A. (2014). Influence of supervisor support on job satisfaction levels: An evaluation of Turkish national police (TNP) officers in the Istanbul police department. *International Journal of Criminal Justice Sciences*, 9, 209-224. Retrieved from <http://www.sascv.org/ijcjs/>.
- Kulik, L., & Rayyan, F. (2003). Spousal relations and well-being: A comparative analysis of Jewish and Arab dual-earner families in Israel. *Journal of Community Psychology*, 31, 57-73.
- Kunin, T. (1955). The construction of a new type of attitude measure. *Personnel Psychology*, 9, 65-78.
- Kusurkar R., Croiset G., Kruitwagen C., & Ten Cate O.T. J. 2010. Validity evidence for the measurement of the strength of motivation for medical school. *Advanced Health Science Education*, 16(2), 183–195
- Kuvaas, B. (2008). An exploration of how the employee–organization relationship affects the linkage between perception of developmental human resource practices and employee outcomes. *Journal of Management Studies*, 45(1), 1-25. doi:10.1111/j.1467-6486.2007.00710.x.
- Knežević, I., Gregov, L., Šimunić, A. (2016). Salience And Conflict Of Work And Family Roles Among Employed Men And Women. *Arh Hig Rada Toksikol, Croatia*, 67(2), 152-163.
- La Guardia, J. G., & Patrick, H. (2008). Self-determination theory as a fundamental theory of close relationships. *Canadian Psychology/Psychologie canadienne*, 49(3), 201. doi: 10.1037/a0012760.
- La Guardia, J. G., Ryan, R. M., Couchman, C. E., & Deci, E. L. (2000). Within-person variation in security of attachment: a self-determination theory perspective on attachment, need fulfillment, and well-being. *Journal of personality and social psychology*, 79(3), 367. doi: 10.1037/0022-3514.79.3.367

- Lambert, E. G. Hogan, N. L., Dial, K. C., Jiang, S., & Khondaker, M. (2012). Is the job burning me out? An exploratory test of the job characteristics model on the emotional burnout of prison staff. *The Prison Journal*, 92 (3), 3–23.
- Lang, F. R., & Heckhausen, J. (2001). Perceived control over development and subjective well-being: differential benefits across adulthood. *Journal of Personality and Social Psychology*, 81(3), 509. doi: 10.1037/0022-3514.81.3.509
- Lapierre, L. M., Spector, P. E., Allen, T. D., Poelmans, S., Cooper, C. L., O’Driscoll, M. P., ... & Kinnunen, U. (2008). Family-supportive organization perceptions, multiple dimensions of work–family conflict, and employee satisfaction: A test of model across five samples. *Journal of Vocational Behavior*, 73(1), 92-106. doi:10.1016/j.jvb.2008.02.001.
- Lee, R., & Klein, A. R. (1982). Structure of Job Diagnostic Survey for public sector occupations. *Journal of Applied Psychology*, 67(4), 515- 519. doi:10.1037/0021-9010.67.4.515.
- Lee N.Y, Zvonkovic A.M, Crawford D.W. (2014). The impact of work-family conflict and facilitation on women’s perceptions of role balance. *Journal of Family Issues*, 35, 1252–12774
- Lee, R. T., & Ashforth, B. E. (1996). A meta-analytic examination of the correlates of the three dimensions of job burnout. *Journal of applied Psychology*, 81(2), 123-133. doi:10.1037/0021-9010.81.2.123
- Leiter M.P.,& Durup J. (1994). The discriminant validity of burnout and depression: a confirmatory factor analytic study. *Anxiety Stress Coping*, 7, 357–73.
- Levesque C.S, Williams G.C, Elliot D., Pickering M.A, Bodenhamer B, & Finley P.J.(2007). Validating the theoretical structure of the Treatment Self-regulation Questionnaire (TSRQ) across three different health behaviors. *Health Educational Research*, 22(5):691–702.
- Lian, H., Ferris, D. L., & Brown, D. J. (2012). Does power distance exacerbate or mitigate the effects of abusive supervision? It depends on the outcome. *Journal of Applied Psychology*, 97(1), 107. doi: 10.1037/a0024610.
- Liden, R. C., Wayne, S. J., & Sparrowe, R. T. (2000). An examination of the mediating role of psychological empowerment on the relations between the job, interpersonal relationships, and work outcomes. *Journal of Applied Psychology*, 85, 407 – 416.
- Liu, G. R., Zhang, S., Zhang, J. H., Lee, C., Wang, Y., & Brownell, M. (2013). Autonomous motivation and chinese adolescents’ creative thinking: The moderating role of parental involvement. *Creativity Research Journal*, 25, 446–456.

- Loscocco, K. , & Bose, C. (1998) Gender and job satisfaction in urban China: the early post-Mao period, *Social Science Quarterly*, 79, 91–109.
- Lu, L., Kao, S., Cooper, C.L., Allen, T.D., Lapierre, L.M., O’Driscoll, M., J., ... Spector, P. (2009). Work resources, work-to-family conflict, and its consequences: A Taiwanese–British cross-cultural comparison. *International Journal of Stress Management*, 16, 25–44.
- Madden, M. E. (1987). Perceived control and power in marriage: A study of marital decision making and task performance. *Personality and Social Psychology Bulletin*, 13, 73–82.
- Madden, M.E, & Janoff-Bulma, R. (1981). Blame, control, and marital satisfaction: Wives’ attributions for conflict in marriage. *Journal of Marriage and the Family*. 43, 663–674.
- Maddi, S. R., Kosoba, S.C., & Hoover, M. (1979). An alienation test. *Journal of Humanistic Psychology*, 19, 73-76.
- Margolis, R., & Myrskylä, M. (2013). Family, money, and health: Regional differences in the determinants of life satisfaction over the life course. *Advances in Life Course Research*, 18, 115–126.
- Martins, L. L., Eddleston, K. A., & Veiga, J. F. (2002). Moderators of the relationship between work-family conflict and career satisfaction. *Academy of Management Journal*, 45(2), 399-409. doi: 10.2307/3069354.
- Maslach, C., & Jackson, S. E. (1986). *Manual Maslach Burnout Inventory*. Palo Alto, CA: Consulting Psychologists Press.
- Maslach, C., Jackson, S. E., & Leiter, M. P. (1996). *Maslach Burnout Inventory*. Manual (3rd ed.). Palo Alto, CA: Consulting Psychologists Press.
- Matthews RA, Barnes-Farrell JL, Bulger CA. (2010). Advancing measurement of work–family boundary characteristics. *Journal of Vocational Behavior*.,77, 447–460.
- Maume, D. J. (2006). Gender differences in restricting work efforts because of family responsibilities. *Journal of Marriage and Family*, 68, 859 – 869.
- Melamed, S., Kushnir, T., & Meir, E. I. (1991). Attenuating the impact of job demands: Additive and interactive effects of perceived control and social support. *Journal of Vocational Behavior*, 39, 42–53.
- Mesmer-Magnus, J. R., & Viswesvaran, C. (2005). Convergence between measures of work-to-family and family-to-work conflict: A meta-analytic examination. *Journal of vocational behavior*, 67(2), 215-232. doi: 10.1016/j.jvb.2004.05.004.

- Metin, Ü. B. (2010). *The antecedents and consequences of burnout, work engagement and workaholism* (Unpublished master's thesis). Middle East Technical University, Ankara, Turkey.
- Michel J.S, Kotrba L.M, Mitchelson J.K, Clark M.A, Baltes B.B. (2011). Antecedents of work-family conflict: A meta-analytic review. *Journal of Organizational Behavior*, 32(5), 689–725. doi: 10.1002/job.695.
- Mihelič, K. K. & Tekavčič, M. (2014). Work-family conflict: A review of antecedents and outcomes. *International Journal of Management & Information System*, 18 (1), 15-25.
- Miller, P. C., Lefcourt, H. M., Holmes, J. G., Ware, E. E., & Saleh, W. E. (1986). Marital locus of control and marital problem solving. *Journal of Personality and Social Psychology*, 51, 161 - 169.
- Millette, V., & Gagne', M. (2008). Designing volunteers' tasks to maximize motivation, satisfaction and performance: The impact of job characteristics on volunteer engagement. *Motivation and Emotion*, 32, 11–22. doi:10.1007/s11031-007-9079-4.
- Milyavskaya, M., & Koestner, R. (2011). Psychological needs, motivation, and well-being: A test of self-determination theory across multiple domains. *Personality and Individual Differences*, 50(3), 387-391. doi: 10.1016/j.paid.2010.10.029.
- Minnotte, K. L., Minnotte, M. C., & Bonstrom, J. (2015). Work–family conflicts and marital satisfaction among US workers: Does stress amplification matter?. *Journal of Family and Economic Issues*, 36(1), 21-33. doi:10.1007/s10834-014-9420-5.
- Molden, D. C., Lucas, G. M., Finkel, E. J., Kumashiro, M., & Rusbult, C. (2009). Perceived Support for Promotion-Focused and Prevention-Focused Goals Associations With Well-Being in Unmarried and Married Couples. *Psychological Science*, 20(7), 787-793. doi: 10.1111/j.1467-9280.2009.02362.x
- Moreau, E., & Mageau, G. (2012). The importance of perceived autonomy support for the psychological health and work satisfaction of health professionals: Not only supervisors count, colleagues too! *Motivation and Emotion*, 36, 268–286. doi:10.1007/s11031-011-9250-9
- Mullan, E., Markland, D., & Ingledew, D. (1997) A graded conceptualisation of self-determination in the regulation of exercise behaviour: Development of a measure using confirmatory factor analytic procedures. *Personality and Individual Differences*, 23, 745–52.

- Myers, S. M., & Booth, A. (1999). Marital strains and marital quality: The role of high and low locus of control. *Journal of Marriage and the Family*, *61*, 423–436. doi:10.2307/353759
- Netemeyer, R. G., Boles, J. S., & McMurrin, R. (1996). Development and validation of work–family conflict and family–work conflict scales. *Journal of Applied Psychology*, *81*, 400–410. doi: 10.1037/0021-9010.81.4.400
- Newman, D. B., Tay, L., & Diener, E. (2014). Leisure and subjective well-being: A model of psychological mechanisms as mediating factors. *Journal of Happiness Studies*, *15*, 555–578. <http://dx.doi.org/10.1007/s10902-013-9435-x>
- Nie Y., Chua B.L., Yeung A.S., Ryan R.M., & Chan W.Y. (2015). The importance of autonomy support and the mediating role of work motivation for well-being: testing self-determination theory in a Chinese work organisation. *International Journal of Psychology*, *50*(4), 245–55. doi: 10.1002/ijop.12110
- Niemiec, C. P., & Ryan, R. M. (2009). Autonomy, competence, and relatedness in the classroom: Applying self-determination theory to educational practice. *School Field*, *7*(2), 133-144.
- Niven, A. G., & Markland, D. (2016). Using self-determination theory to understand motivation for walking: Instrument development and model testing using Bayesian structural equation modelling. *Psychology of Sport and Exercise*, *23*, 90–100.
- Nohe, C., Meier, L. L., Sonntag, K., & Michel, A. (2015). The chicken or the egg? A meta-analysis of panel studies of the relationship between work-family conflict and strain. *Journal of Applied Psychology*, *100*, 522-536. doi:10.1037/a0038012
- Noor, N. M. (2004). Work-family conflict, work-and family-role salience, and women's well-being. *The Journal of social psychology*, *144*(4), 389-406. doi:10.3200/SOCP.144.4.389-406.
- O'Driscoll, M. P., Ilgen, D. R., & Hildreth, K. (1992). Time devoted to job and off-job activities, interrole conflict, and affective experiences. *Journal of applied psychology*, *77*(3), 272. doi: 10.1037/0021-9010.77.3.272.
- Oldham, G. R., & Fried, Y. (2016). Job design research and theory: Past, present and future. *Organizational Behavior and Human Decision Processes*, *136*, 20-35. doi: 10.1016/j.obhdp.2016.05.002/
- Overall, N. C., Fletcher, G. J., & Simpson, J. A. (2010). Helping each other grow: Romantic partner support, self-improvement, and relationship quality. *Personality and Social Psychology Bulletin*, 0146167210383045. doi: 10.1177/0146167210383045.

- Öcal, Ö. (2008). *İş-aile çatışması, iş tatmini ve yaşam tatmini ilişkisini belirlemeye yönelik tekstil işletmesi çalışanlarında bir araştırma* (Unpublished master's thesis). Akdeniz Üniversitesi, Antalya, Turkey.
- Önder I., Beşoluk S., İskender M., Masal E., & Demirhan E. (2014). Circadian preferences sleep quality and sleep patterns, personality, academic motivation and academic achievement of university students. *Learning and Individual Differences, 32*, 184-192. doi: 10.1016/j.lindif.2014.02.003
- Parasuraman, S., Greenhaus, J. H., & Granrose, C. S. (1992). Role stressors, social support, and well-being among two-career couples. *Journal of Organizational behavior, 13*(4), 339-356. doi: 10.1002/job.4030130403.
- Parasuraman, S., Greenhaus, J. H., Rabinowitz, S. R., Bedeian, A. G., & Mossholder, K. W. (1989). Work and family variables as mediators of the relationship between wives' employment and husbands' well-being. *Academy of Management Journal, 32*, 185–201. doi: 10.2307/256426
- Parasuraman, S., Purohit, Y. S., Godshalk, V. M., & Beutell, N. J. (1996). Work and family variables, entrepreneurial career success, and psychological well-being. *Journal of vocational behavior, 48*(3), 275-300. doi:10.1006/jvbe.1996.0025.
- Parasuraman, S., & Simmers, C. A. (2001). Type of employment, work–family conflict and well-being: a comparative study. *Journal of organizational behavior, 22*(5), 551-568. doi: 10.1002/job.102.
- Park, H. I., Jacob, A. C., Wagner, S. H., & Baiden, M. (2014). Job control and burnout: A meta-analytic test of the conservation of resources model. *Applied Psychology: An International Review, 63*, 607–642. doi:10.1111/apps.12008.
- Patrick, B. C., Skinner, E. A., & Connell, J. P. (1993). What motivates children's behavior and emotion? Joint effects of perceived control and autonomy in the academic domain. *Journal of Personality and social Psychology, 65*(4), 781. doi: 10.1037/0022-3514.65.4.781
- Patrick, H., Knee, C. R., Canevello, A., & Lonsbary, C. (2007). The role of need fulfillment in relationship functioning and well-being: a self-determination theory perspective. *Journal of personality and social psychology, 92*(3), 434. doi: 10.1037/0022-3514.92.3.434
- Pattusamy, M., & Jacob, J. (2016). Testing the mediation of work–family balance in the relationship between work– family conflict and job and family satisfaction. *South African Journal of Psychology, 46*. doi:10.1177/0081246315608527.

- Peeters, M. C., Montgomery, A. J., Bakker, A. B., & Schaufeli, W. B. (2005). Balancing Work and Home: How Job and Home Demands Are Related to Burnout. *International Journal of Stress Management*, 12(1), 43. doi: 10.1037/1072-5245.12.1.43
- Pelletier, L. G., Tuson, K. M., & Haddad, N. K. (1997). Client motivation for therapy scale: A measure of intrinsic motivation, extrinsic motivation, and amotivation for therapy. *Journal of Personality Assessment*, 68, 414–435.
- Pleck, J. H., Staines, G. L. and Lang, L. (1980). 'Conflicts between work and family life'. *Monthly Journal of Occupational Psychology*, 53, 245-252.
- Poelmans, S. (2001). *Individual and organizational issues in work-family conflict*. Research paper, 445, IESE. doi: 10.2139/ssrn.887903.
- Preacher, K. J., & Hayes, A. F. (2005). *SPSS and SAS macros for estimating and comparing indirect effects in multiple mediator models*. Retrieved from <http://www.comm.ohio-state.edu/ahayes/>
- Pruessner, J. C., Hellhammer, D. H., & Kirschbaum, C. (1999). Burnout, perceived stress, and cortisol responses to awakening. *Psychosomatic medicine*, 61(2), 197-204. doi: 10.1097/00006842-199903000-00012
- Qu, H. and Zhao, X. (2012), “Employees’ work–family conflict moderating life and job satisfaction”, *Journal of Business Research*, 65(1), 22-28.
- Ratelle, C. F., Simard, K., & Guay, F. (2013). University students’ subjective well-being: The role of autonomy support from parents, friends, and the romantic partner. *Journal of Happiness Studies*, 14(3), 893-910. doi:10.1007/s10902-012-9360-4.
- Reichl, C., Leiter, M.P.& Spinath, F.M., (2014) Work–nonwork conflict and burnout: A meta-analysis. *Human Relations*, 67(8), 979-1005.
- Renn, R. W., & Vandenberg, R. L (1995). The critical psychological states: An underrepresented component in job characteristics model research. *Journal of Management*, 21, 279-303.
- Rice, R. W., Frone, M. R., & McFarlin, D. B. (1992). Work—nonwork conflict and the perceived quality of life. *Journal of Organizational Behavior*, 13(2), 155-168. doi:10.1002/job.4030130205
- Richer, S., Blanchard, C., & Vallerand, R. J. (2002). A motivational model of work turnover. *Journal of Applied Social Psychology*, 32, 2089–2113.
- Richer, S. F., & Vallerand, R. J. (1995). Supervisors' interactional styles and subordinates' intrinsic and extrinsic motivation. *The Journal of Social Psychology*, 135(6), 707-722. doi: 10.1080/00224545.1995.9713974.

- Rosenbaum, M., & Cohen, E. (1999). Equalitarian marriages, spousal support, resourcefulness, and psychological distress among Israeli working women. *Journal of Vocational Behavior, 54*, 102–113. doi:10.1006/jvbe.1998.1644.
- Rothbard, N. P. 2001. Enriching or depleting? The dynamics of engagement in work and family roles. *Administrative Science Quarterly, 46*, 655-684. doi: 10.2307/3094827.
- Rotter, J. B. (1966). Generalized expectancies for internal versus external control of reinforcement. *Psychological Monographs, 80*, 609. doi: 10.1037/h0092976
- Rubio, C., Osca, A., Recio, P., Urien, B. & Peiró, J.M. (2015). Work-family conflict, self- efficacy and emotional exhaustion: a test of longitudinal effects. *Journal of Work and Organizational Psychology, 31*(3), 147-154.
- Rupert, P.A, Stevanivic P., & Hunley, H.A. (2009). Work-family conflict and burnout among practicing psychologists. *Professional Psychology Research and Practice, 40*, 54–61.
- Ryan, R. M. (1995). Psychological needs and the facilitation of integrative processes. *Journal of Personality, 63*, 397–427. doi: 10.1111/j.1467-6494.1995.tb00501.x.
- Ryan, R. M., & Connell, J. P. (1989). Perceived locus of causality and internalization: Examining reasons for acting in two domains. *Journal of Personality and Social Psychology, 57*, 749-761. doi:10.1037/0022-3514.57.5.749.
- Ryan, R. M., & Deci, E. L. (2000). Self-determination theory and the facilitation of intrinsic motivation, social development, and well-being. *American Psychologist, 55*, 68–78. doi: 10.1037/0003-066X.55.1.68.
- Ryan, R. M., & Deci, E. L. (2001). On happiness and human potentials: A review of research on hedonic and eudaimonic well-being. *Annual review of psychology, 52*(1), 141-166. doi: 10.1146/annurev.pstch.52.1.141.
- Ryan, R. M., & Grolnick, W. S. (1986). Origins and pawns in the classroom: Self-report and projective assessments of individual differences in children's perceptions. *Journal of personality and social psychology, 50*(3), 550. doi:10.1037/0022-3514.50.3.550
- Ryan, R. M., La Guardia, J. G., Solky-Butzel, J., Chirkov, V., & Kim, Y. (2005). On the interpersonal regulation of emotions emotional reliance across gender, relationships and cultures. *Personal Relationships, 12*, 145-163.
- Ryan, R. M., Rigby, S., & King, K. (1993). Two types of religious internalization and their relations to religious orientations and mental health. *Journal of Personality and Social Psychology, 65*, 586-596. doi:10.1037/0022-3514.65.3.586

- Schaufeli, W.B. & Bakker, A.B. (2004). Job demands, job resources, and their relationship with burnout and engagement: a multi-sample study. *Journal of Organizational Behavior*, 25, 293-315.
- Schaufeli, W. B., Bakker, A. B., & Van Rhenen, W. (2009). How changes in job demands and resources predict burnout, work engagement, and sickness absenteeism. *Journal of Organizational Behavior*, 30(7), 893-917. doi: 10.1002/job.595
- Schunk, D. H., & Zimmerman, B. J. (Eds.). (2012). *Motivation and self-regulated learning: Theory, research, and applications*. Routledge.
- Seery, B.L., Corrigan, E.A., & Harpel, T. (2008). Job-related emotional labor and its relationship to work-family conflict and facilitation. *Journal Family Economics*, 29, 461-477.
- Seiger, C. P., & Wiese, B. S. (2009). Social support from work and family domains as an antecedent or moderator of work–family conflicts?. *Journal of Vocational Behavior*, 75(1), 26-37. doi: 10.1016/j.jvb.2009.03.001.
- Senécal, C., & Vallerand, R. J. (1999). Construction et validation de l'Échelle de Motivation envers les Activités Familiales (ÉMAF) [Construction and validation of the Motivation Toward Family Activities Scale]. *Revue Européenne de Psychologie Appliquée*, 49, 261-274.
- Senecal, C., Vallerand, R. J., & Guay, F. (2001). Antecedents and outcomes of work-family conflict: toward a motivational model. *Personality and Social Psychology Bulletin*, 27, 176-186. doi: 10.1177/0146167201272004.
- Shockley, K. M., & Singla, N. (2011). Reconsidering work—family interactions and satisfaction: A meta-analysis. *Journal of Management*, 37(3), 861-886. doi: 10.1177/0149206310394864.
- Shore, L. M., & Tetrick, L. E. (1991). A construct validity study of the Survey of Perceived Organizational Support. *Journal of Applied Psychology*, 76, 637–643.
- Simons, R. (1992). Parental status strains, salience of parental identity and gender differences in psychological distress. *Journal of Health and Social Behavior*, 33, 25-35.
- Skinner, B.F. (1953). *Science and Human Behavior*. New York: Macmillan.
- Skinner, E. A. (1996). A guide to constructs of control. *Journal of personality and social psychology*, 71(3), 549. doi: 10.1037/0022-3514.71.3.549

- Skinner, E. A., Wellborn, J. G., & Connell, J. P. (1990). What it takes to do well in school and whether I've got it: A process model of perceived control and children's engagement and achievement in school. *Journal of educational psychology*, 82(1), 22. doi: 10.1037/0022-0663.82.1.22.
- Spector P.E. (1985). Higher-order need strength as a moderator of the job scope-employee outcome relationship: A meta-analysis. *Journal of Occupational Psychology*, 58, 119-127.
- Spector, P. E. (1986). Perceived control by employees: A meta-analysis of studies concerning autonomy and participation at work. *Human relations*, 39 (11), 1005-1016. doi: 10.1177/001872678603901104
- Spector, P. E. (1997). *Job satisfaction: Application, assessment, causes, and consequences*. Thousand Oaks, CA: Sage.
- Spector, P. E., Allen, T. D., Poelmans, S. A. Y., Lapierre, L. M., Cooper, C. L., & O'Driscoll, M., ... Pagon, M. (2007). Cross-national differences in relationships of work demands, job satisfaction, and turnover intentions with workfamily conflict. *Personnel Psychology*, 60, 805–835.
- Stets, J. E., & Burke, P. J. (2000). Identity theory and social identity theory. *Social psychology quarterly*, 224-237. doi: 10.2307/2695870
- Stoeva, A. Z., Chiu, R. K., & Greenhaus, J. H. (2002). Negative affectivity, role stress, and work-family conflict. *Journal of Vocational Behavior*, 60, 1–16.
- Stryker, S. (1980). *Symbolic Interactionism: A Social Structural Version*. Menlo Park, CA: Benjamin Cummings.
- Stryker, S. (1987). Identity theory: Developments and extensions. In K. Yardley & T. Honess (Eds.), *Self and identity: Psychosocial perspectives* (pp. 89-103). Oxford, England: John Wiley.
- Stryker, S., & Burke, P. J. (2000). The past, present and future of identity theory. *Social Psychology Quarterly*, 63, 284-297. doi: 10.2307/2695840
- Stryker, S., & Serpe, (1982). Commitment, identity salience and role behavior: Theory and research example. In W. Ickes & E. S. Knowles (Eds.) *Personality, roles, and social behavior*. New York: Springer-Verlag. doi: 10.1007/978-1-4613-9469-3_7
- Sultan, S. (2012). Examining the Job Characteristics: A Matter of Employees' Work Motivation and Job Satisfaction. *Journal of behavioural sciences*, 22(2), 13-22.

- Sungur, S. and Senler, B. (2010). Students' achievement goals in relation to academic motivation, competence expectancy, and classroom environment perceptions. *Educational Research and Evaluation*, 16, 303–324. doi:10.1080/13803611.2010.523291
- Tajfel, H., & Turner, J. C. (1979). An integrative theory of intergroup conflict. *The social psychology of intergroup relations*, 33(47), 74.
- Tajfel, H., & Turner, J. C. (1986). The social identity theory of intergroup behavior. In S. Worchel & W. G. Austin (Eds.), *Psychology of intergroup relations*, 7-24. Chicago: Nelson-Hall.
- Tang, S., Siu, O. and Cheung, F. (2014). A study of work–family enrichment among Chinese employees: The mediating role between work support and job satisfaction. *Applied psychology: An International Review*, 63 (1), 130–150.
- Tayfur, Ö., & Arslan, M. (2013). The role of lack of reciprocity, supervisory support, workload, and work-family conflict on exhaustion: Evidence from physicians. *Psychology, Health & Medicine*, 18, 564–575. doi: 10.1080/13548506.2012.756535.
- Teuchmann K, Totterdell P, Parker SK. 1999. Rushed, unhappy, and drained: an experience sampling study of relations between time pressure, perceived control, mood, and emotional exhaustion in a group of accountants. *Journal of Occupational Health Psychology*, 4(1), 37–54
- Thoits, P.A. (1992). Identity structures and psychological well being: Gender and marital status comparisons. *Social Psychology Quarterly*, 55, 236-256.
- Thomas, L. T., & Ganster, D. C. (1995). Impact of family-supportive work variables on work-family conflict and strain: A control perspective. *Journal of applied psychology*, 80(1), 6. doi: 10.1037/0021-9010.80.1.6.
- Thompson, C. A., Beauvais, L. L., & Lyness, K. S. (1998). When work–family benefits are not enough: The influence of work–family culture on benefit utilization, organizational attachment, and work–family conflict. *Journal of Vocational Behavior*, 54, 392–415.
- Thompson, S. C. (1991). Intervening to enhance perceptions of control. In C. R. Snyder & D. R. Forsyth (Eds.), *Handbook of social and clinical psychology* (pp. 607-623). New York: Pergamon.
- Thompson, C. A., & Prottas, D. J. (2006). The mediating role of perceived control on the relationship between organizational family support, job autonomy, and employee wellbeing. *Journal of Occupational Health Psychology*, 11, 100-118.

- Tremblay, M. A., Blanchard, C. M., Taylor, S., Pelletier, L. G., & Villeneuve, M. (2009). Work Extrinsic and Intrinsic Motivation Scale: Its value for organizational psychology research. *Canadian Journal of Behavioural Science/Revue canadienne des sciences du comportement*, 41(4), 213. doi: 10.1037/a0015167
- Tubin, R. (2007). *Multiple roles, work-family conflict and related outcomes* (Unpublished master's thesis). Marmara Üniversitesi, İstanbul, Turkey.
- Turkish Labor Law (2013, 16, August). *Official Gazette* (Issue No: 28737). Retrieved from <http://www.mevzuat.gov.tr/MevzuatMetin/1.5.4857.pdf>
- Turkish Labor Law (2003, 10, June). *Official Gazette* (Issue No: 25134). Retrieved from <http://www.mevzuat.gov.tr/MevzuatMetin/1.5.4857.pdf>
- Turliuc, M. N., & Buliga, D. (2014). Job and Family Satisfaction and Work-Family Enhancement. Mediating Processes. *Procedia-Social and Behavioral Sciences*, 159, 115-119. doi:10.1016/j.sbspro.2014.12.340.
- Turner, J. C., & Tajfel, H. (1986). The social identity theory of intergroup behavior. *Psychology of intergroup relations*, 7-24.
- Türkmen, M. (2013). The Relationships between Gender, Physical Self-Perception, Sport Experience, Motivation Orientations and Academic Success. *International Journal of Academic Research*, 5 (5), 66-72.
- Uysal, A., Lin, H. L., & Knee, C. R. (2010). The role of need satisfaction in self-concealment and well-Being. *Personality and Social Psychology Bulletin*, 36, 187-199. doi:10.1177/0146167209354518.
- Ünal-Karagüven (2012). The adaptation of academic motivation scale to Turkish. *Educational Sciences: Theory and Practice*, 12, 2599-2620.
- Ünüvar, T.G. (2006). *An Integrative Model Of Job Characteristics, Job Satisfaction, Organizational Commitment, And Organizational Citizenship Behavior* (Unpublished doctoral dissertation). Middle East Technic University, Ankara, Turkey.
- Üzümcüoğlu, Y. (2013). *Bidirectional nature of work family conflict: the antecedents and outcomes of work to family conflict and family to work conflict* (Unpublished master's thesis). Middle East Technical University, Ankara, Turkey.
- Vallerand, R. J. (1997). Toward a hierarchical model of intrinsic and extrinsic motivation. In M. P. Zanna (Ed.), *Advances in experimental social psychology* (Vol. 29, pp. 271-360). San Diego: Academic Press. doi:10.1016/S0065-2601(08)60019-2.

- Vallerand, R. J., Blanchard, C. M., Mageau, G. A., Koestner, R., Ratelle, C., Le'onard, M., Gagne', M., & Marsolais, J. (2003). Les passions de l'âme: On obsessive and harmonious passion. *Journal of Personality and Social Psychology, 85*, 756–767.
- Vallerand, R. J., Pelletier, L. G., Blais, M. R., Brière, N. M., Senécal, C., & Vallières, E. F. (1992). The Academic Motivation Scale: A measure of intrinsic, extrinsic, and amotivation in education. *Educational and Psychological Measurement, 52*, 1003–1017.
- Van den Broeck, A., Lens, W., De Witte, H., & Van Coillie, H. (2013). Unravelling the importance of the quantity and the quality of workers' motivation for well-being: A person-centered perspective. *Journal of Vocational Behaviour, 82*, 69–78. doi:doi:10.1016/j.jvb.2012.11.005
- Van den Broeck, A., Vansteenkiste, M., De Witte, H., & Lens, W. (2008). Explaining the relationships between job characteristics, burnout, and engagement: The role of basic psychological need satisfaction. *Work & Stress, 22*(3), 277-294. doi: 10.1080/02678370802393672.
- Vansteenkiste, M., & Deci, E. L. (2003). Competitively contingent rewards and intrinsic motivation: Can losers remain motivated? *Motivation and Emotion, 27*, 273–299. doi: 10.1023/A:1026259005264.
- Varoğlu, D. (1986). *Relationship of job characteristics to satisfaction and motivation: A study on academicians*. (Unpublished master's thesis). Middle East Technical University, Ankara, Turkey.
- Verloigne, M., De Bourdeaudhuij, I., Tanghe, A., D'Hondt, E., Theuwis, L., Vansteenskite, M., et al. (2011). Self-determined motivation towards physical activity in adolescents treated for obesity: an observational study. *International Journal of Behavioral Nutrition and Physical Activity, 8*, 97e108. <http://dx.doi.org/10.1186/1479-5868-8-97>.
- Voydanoff, P. (2001). Incorporating community into work and family research: A review of basic relationships. *Human Relations, 54*, 1609–1637.
- Voydanoff, P. (2004a). The effects of work demands and resources on work-to-family conflict and facilitation. *Journal of Marriage and Family, 66*, 398–412. doi: 10.1111/j.1741-3737.2004.00028.x.
- Voydanoff, P. (2004b). The effects of work and community resources and demands on family integration. *Journal of Family and Economic Issues, 25*, 7–23. doi:10.1023/B:JEEI.0000016721.71785.06.

- Wall, T. D., Clegg, C. W., & Jackson, P. R. (1978). An evaluation of the job characteristics model. *Journal of Occupational Psychology*, 51(2), 183-196. doi:10.1111/j.2044-8325.1978.tb00413.x.
- Warner, M. A., & Hausdorf, P. A. (2009). The positive interaction of work and family roles: Using need theory to further understand the work-family interface. *Journal of Managerial Psychology*, 24(4), 372-385.
- Warner, M. A., & Hausdorf, P. A. (2009). Understanding work-to-family conflict: the role of organization and supervisor support for work-life issues. *Organization Management Journal*, 6(3), 130-145.
- Warr, P. B. (1990). Decision latitude, job demands, and employee well-being. *Work and Stress*, 4, 285-294.
- Wayne, J., Musisca, N., & Fleeson, W. (2002). Relationships of the big five to work-family conflict and facilitation. *Journal of Vocational Behavior*, 64, 108-130. doi:10.1016/S0001-8791(03)00035-6.
- Wright, T. A., & Cropanzano, R. (1998). Emotional exhaustion as a predictor of job performance and voluntary turnover. *Journal of applied psychology*, 83 (3), 486. doi:10.1037/0021-9010.83.3.486
- Xanthopoulou, D., Bakker, A. B., Demerouti, E., & Schaufeli, W. B. (2007). The role of personal resources in the job demands-resources model. *International journal of stress management*, 14(2), 121. doi: 10.1037/1072-5245.14.2.121
- Xu, Y., & Burleson, B. R. (2004). The association of experienced spousal support with marital satisfaction: Evaluating the moderating effects of sex, ethnic culture, and type of support. *The Journal of Family Communication*, 4, 123-145.
- Yıldırım, İ. (2004). Eş destek ölçeğinin geliştirilmesi. *Psikolojik Danışma ve Rehberlik Dergisi*, 22(3), 19-26.
- Yıldırım, D., & Aycan, Z. 2008. Nurses' work demands and work-family conflict: A questionnaire survey. *International Journal of Nursing Studies*, 45, 1366-1378.
- Yüksel, İ. (2005). İş-Aile Çatışmasının Kariyer Tatmini, İş Tatmini ve İş Davranışları İle İlişkisi. *Atatürk Üniversitesi İktisadi ve İdari Bilimler Fakültesi Dergisi*, 19 (2), 301-314.
- Yürür S., Sarıkaya M. (2012) The effects of workload, role ambiguity, and the social support in burnout among social workers in Turkey. *Administration in Social Work*, 36(5), 457-478. doi:10.1080/03643107.2011.613365.

- Zahidi, S., & Ibarra, H. (2010). *The Corporate Gender Gap Report*. Retrieved from <http://jpn.up.pt/pdf/corporate2010.pdf>
- Zaniboni, S., Truxillo, D. M., & Fraccaroli, F. (2013). Differential effects of task variety and skill variety on burnout and turnover intentions for older and younger workers. *European Journal of Work and Organizational Psychology*, 22(3), 306-317. doi: 10.1080/1359432X.2013.782288
- Zargar, M. S., Vandenberghe, C., Marchand, C., & Ayed, A. K. B. (2014). Job scope, affective commitment, and turnover: The moderating role of growth need strength. *Journal of occupational and organizational psychology*, 87(2), 280-302. doi: 10.1111/joop.12046.
- Zapf, D., Vogt, C., Seifert, C., Mertini, H., & Isic, A. (1999). Emotion work as a source of stress: The concept and development of an instrument. *European Journal of work and organizational psychology*, 8(3), 371-400. doi:10.1080/135943299398230
- Zedeck, S., & Mosier, K. L. (1990). Work in the family and employing organization. *American Psychologist*, 45(2), 240. doi: 10.1037/0003-066X.45.2.240.
- Zhang, M., Griffeth, R.W. and Fried, D.D. (2012), Work-family conflict and individual outcomes. *Journal of Managerial Psychology*, 27 (7), 696-713.
- Zuckerman, M., Larrance, D. T., Porac, J. F. A., & Blanck, P. D. (1980). Effects of fear of success on intrinsic motivation, causal attributions, and choice behavior. *Journal of Personality and Social Psychology*, 39, 503-513

APPENDICES

A1. PARTICIPANT INFORMED CONSENT

Bu çalışma, ODTÜ Sosyal Psikoloji doktora öğrencisi ve Çankaya Üniversitesi Psikoloji Bölümü öğretim görevlisi Aslı Yalçın tarafından Prof. Dr. Reyhan Bilgiç danışmanlığında yürütülen bir çalışmadır. Doktora tezi olacak bu çalışmanın amacı evli ve çocuklu çalışanların iş-aile dengesini nasıl ve ne derecede sağladıklarını incelemektir. Çalışmaya katılım tamamen gönüllülük temelinde olmalıdır. Çalışma için kullanılacak anketlerde sizden kimlik belirleyici hiçbir bilgi istenmemektedir. Cevaplarınız kesinlikle gizli tutulacak ve sadece araştırmacılar tarafından değerlendirilecektir; elde edilecek bilgiler yalnızca bilimsel yayınlarda kullanılacaktır.

Ankette iş ve aile hayatınıza ilişkin bir takım sorular bulunmaktadır. Bu sorulara dürüst ve samimi cevaplar vermeniz araştırmanın güvenilirliği ve geçerliği açısından son derece önemlidir. Anketi tamamlamak yaklaşık olarak 30-40 dakika sürmektedir. Ankette sizden genel olarak kişisel rahatsızlık verecek bilgiler istenmemektedir. Ancak, katılım sırasında sorulardan ya da herhangi başka bir nedenden ötürü kendinizi rahatsız hissederseniz cevaplama işini yarıda bırakıp, çalışmaya katılmamakta serbestsiniz. Böyle bir durumda anketi uygulayan kişiye, anketi tamamlamadığınızı söylemek yeterli olacaktır. Anket sonunda, bu çalışmayla ilgili sorularınız cevaplanacaktır. Bu çalışmaya katıldığınız için şimdiden teşekkür ederiz.

Çalışma hakkında daha fazla bilgi almak için aşağıdaki isimlere danışabilirsiniz.

Araştırmacı: Öğr. Gör. Aslı Yalçın

Tel: (0 312) 233 14 54; E- posta: asliyalcin@cankaya.edu.tr)

Tez Danışmanı: Prof. Dr. Reyhan Bilgiç

Tel: (0312) 210 31 85; E-posta: rey@metu.edu.tr)

Bu çalışmaya tamamen gönüllü olarak katılıyorum ve istediğim zaman yarıda kesip çıkabileceğimi biliyorum. Verdiğim bilgilerin bilimsel amaçlı yayınlarda kullanılmasını kabul ediyorum. (Formu doldurup imzaladıktan sonra uygulayıcıya geri veriniz).

Tarih

İmza

----/----/-----

A2. PARTICIPANT DEBRIEFING FORM

Bu çalışma daha önce de belirtildiği gibi Çankaya Üniversitesi Psikoloji Bölümü öğretim görevlisi ve ODTÜ Sosyal Psikoloji doktora öğrencisi Aslı Yalçın tarafından yürütülen bir çalışmadır. Doktora tezi olacak bu çalışmada temel olarak, evli, çalışan ve çocuk sahibi olan bireylerin iş ve aile hayatlarını nasıl ve ne derecede dengelediği ile ilgilidir.

İlgili literatür, iş ve aile ortamındaki çeşitli faktörlerin bireylerin kurdukları iş-aile dengesini etkileyeceğini göstermektedir. Ayrıca, Deci ve Ryan (1985b, 2000) tarafından geliştirilen Öz-Belirleme Kuramı'na göre farklı güdülenme (motivasyon) çeşitli farklı davranış düzenlemelerine yol açacağı için, bireylerin hem işe hem de aile hayatına yönelik güdülenme tiplerinin iş-aile dengesini etkileyeceği düşünülmektedir. Buna göre, işlerine veya aile hayatlarına karşı kontrollü güdülenme geliştirmiş bireylerin daha fazla iş-aile çatışması yaşamaları beklenmektedir. Yüksek seviyede iş-aile çatışması yaşayan bireylerin ise hem aile hem de iş hayatlarında daha fazla tükenme duygusu ve daha az doyum yaşayacakları, neticesiyle de hayattan aldıkları tatminin düşeceği öngörülmektedir. Diğer taraftan, iş ve/veya aile hayatlarına karşı otonom güdülenme geliştirmiş bireylerin iş-aile dengesini daha iyi kurabilecekleri düşünülmektedir. Bu ilişkileri ortaya çıkarmak amacıyla yapılan bu çalışmada, evli, çalışan ve çocuk sahibi olan yetişkinlere anket verilecek ve katılımcılardan bu anketleri cevaplamaları istenecektir. Katılımcıların, ankette bulunan sorulara verecekleri cevapların kişilere ve farklı faktörlere göre değişmesi beklenmektedir.

Bu çalışmadan alınacak ilk verilerin nisan ayının başında elde edilmesi amaçlanmaktadır. Elde edilen bilgiler **sadece bilimsel araştırma ve yazılarda** kullanılacaktır. Çalışmanın sonuçlarını öğrenmek ya da bu araştırma hakkında daha fazla bilgi almak için aşağıdaki isimlere başvurabilirsiniz. Bu araştırmaya katıldığınız için tekrar çok teşekkür ederiz.

Öğr. Gör. Aslı Yalçın (Tel: 0 312 233 14 54 ; E-posta: asliyalcin@cankaya.edu.tr)

Prof. Dr. Reyhan Bilgiç (Tel: 0 312 210 31 85; rey@metu.edu.tr)

B1. WORK-FAMILY CONFLICT & FAMILY-WORK CONFLICT SCALE

Aşağıda, işinize ve ailenize yönelik düşüncelerinizi yansıtan ifadeler verilmiştir. Lütfen her ifadeye ne derecede katıldığınıza karar veriniz. Değerlendirmenizi yaparken “hiç katılmıyorum” dan (1), “tamamen katılıyorum” a (5) doğru uzanan cevap seçeneklerini kullanınız ve uygun rakamı daire içine alınız.

	Hiç Katılmıyorum	Biraz Katılmıyorum	Kararsızım	Biraz Katılıyorum	Tamamen Katılıyorum
1. İşimin yarattığı stres aileme karşı olan görevlerimi yerine getirmemi zorlaştırmaktadır.	1	2	3	4	5
2. İşime harcadığım zaman aileme karşı sorumluluklarımı yerine getirmemi zorlaştırmaktadır.	1	2	3	4	5
3. İşimin bana yüklediği sorumluluklardan dolayı aileme ilgili yapmak istediğim bazı şeyleri yapamıyorum.	1	2	3	4	5
4. İşim yüzünden, ailece yaptığımız planları değiştirmek zorunda kalırım.	1	2	3	4	5
5. İşimle ilgili sorumluluklarım aile hayatımı etkiliyor.	1	2	3	4	5
6. Aileme ilgili sıkıntılarım, iş performansımı olumsuz etkiler.	1	2	3	4	5
7. Aileme ayırmam gereken zaman nedeniyle, işlerimi ertelediğim olur.	1	2	3	4	5
8. Ailemin ya da eşimin talepleri, işimi etkilemektedir.	1	2	3	4	5
9. Aile hayatım yüzünden işimdeki temel sorumluluklarım aksayabiliyor.	1	2	3	4	5
10. Ailemin ya da eşimin taleplerinden dolayı işimle ilgili olarak yapmak istediğim bazı şeyleri yapamam.	1	2	3	4	5

B2.WORK EXTRINSIC AND INTRINSIC MOTIVATION SCALE (WEIMS)

Aşağıda, şu andaki işinizde neden çalıştığınıza yönelik maddeler bulunmaktadır. Lütfen 1 (*Hiç Uygun Değil*)’den 5’e (*Tamamen Uygun*)’ye kadar derecelendirilmiş ölçeği kullanarak, her bir maddenin işinizi yapma nedenlerinize ne derecede uyduğunu belirtiniz.

İşinizi neden yapıyorsunuz?

	Hiç uygun değil	Biraz Uygun değil	Kararsızım	Biraz Uygun	Tamamen Uygun
1. Belirli bir yaşam standardı sağladığı için.	1	2	3	4	5
2. Bana kazandırdığı gelir için.	1	2	3	4	5
3. Bu soruyu ben de kendime soruyorum, bu işe dair önemli görevleri yerine getiremiyorum gibi görünüyor.	1	2	3	4	5
4. Yeni şeyler öğrenmekten oldukça keyif aldığım için.	1	2	3	4	5
5. Çünkü bu iş kim olduğumun önemli bir parçası haline geldi.	1	2	3	4	5
6. Çünkü bu işte başarılı olmak istiyorum, eğer olamazsam kendimden oldukça utanç duyarım.	1	2	3	4	5
7. Kariyer hedeflerime ulaşmak için.	1	2	3	4	5
8. İlginç zorluklarla mücadele etmekten aldığım tatmin için.	1	2	3	4	5
9. Para kazanmamı sağladığı için.	1	2	3	4	5
10. Çünkü bu iş, hayatımı yaşamak için seçmiş olduğum yolun bir parçası.	1	2	3	4	5
11. Bu işte çok iyi olmak istediğim için, aksi halde büyük bir hayal kırıklığı yaşarım.	1	2	3	4	5

İşinizi neden yapıyorsunuz?

	Hiç uygun değil	Biraz Uygun değil	Kararsızım	Biraz Uygun	Tamamen Uygun
12. Nedenini ben de bilmiyorum, hiç de gerçekçi olmayan şartlar altında çalışıyoruz.	1	2	3	4	5
13. Çünkü bu hayatta kazanan olmak istiyorum.	1	2	3	4	5
14. Çünkü bu iş, hayatımdaki önemli hedeflere ulaşmak için seçtiğim bir iş çeşidi.	1	2	3	4	5
15. Yapılması zor olan işlerde başarılı olmaktan aldığım keyif için.	1	2	3	4	5
16. Çünkü bu çeşit bir iş bana güvence sağlıyor.	1	2	3	4	5
17. Bilmiyorum, bizden çok fazla şey bekleniyor.	1	2	3	4	5
18. Çünkü bu iş hayatımın bir parçası.	1	2	3	4	5

B3. JOB DIAGNOSTIC SURVEY

Aşağıda şu anda yapmakta olduğunuz işinizin temel özellikleri ile ilgili sorular bulunmaktadır. Lütfen her bir soru için 1'den 5'e doğru uzanan cevap seçeneklerini kullanarak en uygun cevabı yansıtan rakamı daire içine alınız.

Örnek: İşinizi nasıl yapacağınıza ne derece kendiniz karar verebilirsiniz?

1	2	3	4	5
Çok az; bu iş tabiatı gereği iş kişiye nasıl ve ne zaman çalışacağı konusunda hemen hemen hiç karar verme imkanı tanımaz.		Orta derecede; birçok şey standart hale getirildiğinden bu iş yapmanın kontrolü altında değildir, ama işle ilgili bazı kararlar alınmasına imkan tanır.		Çok fazla; bu işte ne zaman ve nasıl çalışacağı konusundaki karar tamamen işi yapmanın sorumluluğu altındadır.

NOT: Eğer işinizi nasıl yapacağınıza orta dereceden az bir şekilde kendinizin karar verebildiğinizi düşünüyorsanız 2 seçeneğini, orta dereceden daha fazla bir şekilde kendinizin karar verebildiğinizi düşünüyorsanız 4 seçeneğini işaretleyiniz.

1. İşinizi nasıl yapacağınıza ne derece kendiniz karar verebilirsiniz?

1	2	3	4	5
Çok az; bu iş tabiatı gereği iş kişiye nasıl ve ne zaman çalışacağı konusunda hemen hemen hiç karar verme imkanı tanımaz.		Orta derecede; birçok şey standart hale getirildiğinden bu iş yapmanın kontrolü altında değildir, ama işle ilgili bazı kararlar alınmasına imkan tanır.		Çok fazla; bu işte ne zaman ve nasıl çalışacağı konusundaki karar tamamen işi yapmanın sorumluluğu altındadır.

2. İşiniz ne ölçüde kendi içinde bir bütündür? Yani, yaptığımız şey belirli bir başı ve sonu olan bütün bir iş midir? Yoksa başkaları ve ya otomatik makineler tarafından bitirilen bir işin sadece küçük bir parçası mıdır?

1	2	3	4	5
Bu iş bir bütünün son derece ufak bir parçasıdır. Çalışmalarımın sonucu nihai ürün veya hizmette görülmez.		Bu iş bir bütünün orta büyüklükte bir parçasıdır. Çalışmalarım nihai ürün veya hizmette görülebilir.		Bu iş başından sonuna kadar benim bitirdiğim bir bütünü kapsar. Çalışmalarımın sonucu kolaylıkla nihai ürün veya hizmette görülür.

3. İşinizde ne derece çeşitlilik vardır? Yani, işiniz çeşitli beceri ve yetenekleri kullanarak birçok değişik şey yapmayı ne ölçüde gerektirir?

1	2	3	4	5
Çok az; bu iş sürekli olarak aynı alışılmış şeyleri tekrar tekrar yapmayı gerektirir.		Orta derecede çeşitlilik vardır.		Çok fazla; bu iş birçok değişik beceri ve yetenekleri kullanarak birçok şey yapmayı gerektirir.

4. Genel olarak, işiniz ne derece önemli ve anlamlıdır? Yani, yaptığımız işin sonucu insanların hayatlarını veya durumlarını önemli derecede etkiler mi?

1	2	3	4	5
Çok anlamlı değil; çalışmalarımın sonucunun diğer insanlar üzerinde fazla bir etkisi yoktur.		Orta derecede anlamlı ve önemlidir.		Çok fazla; çalışmalarımın sonucunun diğer insanlar üzerinde çok önemli etkisi vardır.

5. Performansızın iyi olup olmadığına yönelik bilgiyi işin kendisinden almak ne derece mümkündür? Yani işinizin kendisi, amirlerinizin veya mesai arkadaşlarınızın sağlayabileceği bilgiden başka başarılı olup olmadığımız konusunda ne kadar ipucu sağlar?

1	2	3	4	5
Çok az; bu iş öyle düzenlenmiştir ki işi yapan nasıl yaptığı konusunda bir bilgiye sahip olmadan devamlı çalışır.		Orta derecede; bu işi yapmak bazen işi yapana performansla ilgili bilgi sağlar.		Çok fazla; bu işin düzenleniş biçimi işin nasıl yapıldığı hakkında sürekli bilgi verir.

Aşağıda, herhangi bir işi tanımlamak için kullanılabilen ifadeler sıralanmıştır. Bu ifadelerin işinizi ne kadar doğru tanımladığını belirtiniz. Buna karar verirken işinizi sevip sevmediğinize bakmaksızın değerlendirmelerinizi yapmanız gerekmektedir. Değerlendirmenizi yaparken aşağıda “çok yanlış” tan (1), “ çok doğru” ya (5) doğru uzanan cevap seçeneklerini kullanınız. Her ifadenin ne oranda doğru olduğunu belirleyiniz ve uygun rakamı daire içine alınız.

Verilen ifade işiniz için ne derece geçerlidir?

	Çok yanlış	Kısmen yanlış	Emin değilim	Kısmen doğru	Çok doğru
1. İşim bir dizi karmaşık ve yüksek düzeyde beceri kullanmayı gerektirir.	1	2	3	4	5
2. İşim bir bütün işi başından sonuna kadar yapmaya olanak tanıyacak biçimde düzenlenmiştir.	1	2	3	4	5
3. İşimin gerektirdiklerini yapmak başarıımı belirlemek açısından birçok imkan sağlar.	1	2	3	4	5
4. İşim oldukça basit ve tekrarlanan bir niteliktedir.	1	2	3	4	5
5. İşimin nasıl yapıldığı birçok kişiyi etkiler.	1	2	3	4	5
6. İşim kişisel inisiyatifimi veya yargımı kullanmama asla imkan tanımaz.	1	2	3	4	5
7. İşim başladığım iş bölümlerini tamamen bitirmeme olanak sağlar.	1	2	3	4	5
8. İşim ne derece başarılı olduğum konusunda bana çok az ipucu sağlar.	1	2	3	4	5
9. İşimi nasıl yapacağım konusunda bağımsızlık ve özgürlüğüm vardır.	1	2	3	4	5
10. İşim burada yapılan işlerin toplamı düşünüldüğünde, çok önemli ve anlamlı değildir.	1	2	3	4	5

B4. WORK SUPPORT SCALE

Aşağıda şu anki işyerinizde amiriniz ve iş arkadaşlarınız ile ilişkilerinize yönelik ifadeler verilmiştir. Lütfen her bir ifadeyi ne sıklıkta yaşadığınızı değerlendiriniz. Değerlendirmenizi yaparken aşağıda “hiçbir zaman” dan (1) “her zaman” a (5) doğru uzanan cevap seçeneklerini kullanınız. Her ifade için **size uygun olan cevap seçeneği** hangisi ise o seçeneği işaretleyiniz.

	Hiçbir zaman	Nadiren	Bazen	Sık Sık	Her zaman
1. Amirim işteki sorunlarım ya da isteklerime ilgi gösterir.	1	2	3	4	5
2. Amirim tarafından değer gördüğümü hissedirim.	1	2	3	4	5
3. Amirim bana karşı yakın ve sıcaktır.	1	2	3	4	5
4. Lazım olduğunda iş arkadaşlarımdan yardım isteyebilirim.	1	2	3	4	5
5. İşte zorluklarla karşılaştığımda iş arkadaşlarımdan bana destek olacağına güvenirim.	1	2	3	4	5
6. İş arkadaşlarımdan beni değerli bulduğunu hissediyorum.	1	2	3	4	5

B5. EMOTIONAL EXHAUSTION AT WORK SCALE

Aşağıda, işinize yönelik duygularınızı yansıtan ifadeler verilmiştir. Lütfen her bir ifadeyi ne sıklıkla yaşadığınıza karar veriniz. Değerlendirmenizi yaparken “hiç zamandan”dan (1), “her zaman”a (5) doğru uzanan cevap seçeneklerini kullanınız ve uygun rakamı daire içine alınız.

	Hiçbir Zaman	Nadiren	Bazen	Sık Sık	Her zaman
1. İşimden soğuduğumu hissediyorum.	0	1	2	3	4
2. İş dönüşü ruhen tükenmiş hissediyorum.	0	1	2	3	4
3. Sabah kalktığımda bir gün daha bu işi kaldıramayacağımı düşünüyorum.	0	1	2	3	4
4. İşimin beni kısıtladığımı hissediyorum.	0	1	2	3	4
5. İşimde çok fazla çalıştığımı hissediyorum.	0	1	2	3	4

B6. JOB SATISFACTION SCALE

Aşağıda, işinize yönelik düşüncelerinizi yansıtan ifadeler verilmiştir. Lütfen her bir ifadeyi ne sıklıkla yaşadığınıza karar veriniz. Değerlendirmenizi yaparken “hiç katılmıyorum” dan (1), “tamamen katılıyorum” a (7) doğru uzanan cevap seçeneklerini kullanınız ve uygun rakam I daire içine alınız.

	Hiç katılmıyorum	Katılmıyorum	Biraz Katılmıyorum	Kararsızım	Biraz Katılıyorum	Katılıyorum	Tamamen katılıyorum
1. Genel olarak konuşmak gerekirse, bu iş beni çok tatmin ediyor.	1	2	3	4	5	6	7
2. Bu işte yaptığım çalışmalar, genel olarak, beni tatmin ediyor.	1	2	3	4	5	6	7
3. Genel olarak konuşmak gerekirse, işimi seviyorum.	1	2	3	4	5	6	7

Lütfen, genel olarak işinizden ne derecede memnun olduğunuzu en iyi temsil eden yüz ifadesinin altındaki ya da üstündeki rakamı işaretleyiniz. (**Kadın katılımcılar kadın yüz ifadesinin üstündeki rakamlardan birini, erkek katılımcılar erkek yüz ifadesinin altındaki rakamlardan birini işaretlemelidir.**)

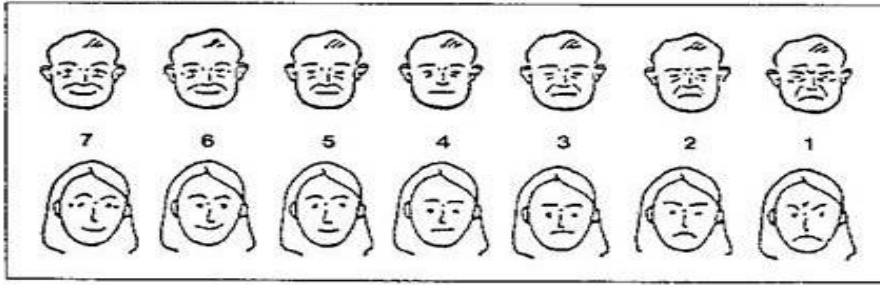

B7.SPOUSAL SUPPORT SCALE

Aşağıda eşinizin davranışlarına ilişkin birtakım ifadeler yer almaktadır. Lütfen bu ifadelere ne derecede katıldığınızı belirtiniz. Değerlendirmenizi yaparken “*bana uygun değil*” den (1), “*bana uygun*” a (3) doğru uzanan cevap seçeneklerini kullanınız. Düşüncelerinizi en uygun yansıtan rakamı daire içine alınız.

	Bana uygun değil	Kısmen Uygun	Bana uygun
1. Eşim bana hoş espriler yapar.	1	2	3
2. Eşim yaptıklarımı destekler.	1	2	3
3. Eşim benimle olmak için zaman yaratmay çalışır.	1	2	3
4. Eşim bana sarılır, üzerime titrer.	1	2	3
5. Eşim bana yanımda olduğunu hissettirir.	1	2	3
6. Eşim bana şefkat gösterir.	1	2	3
7. Eşim beni sever, okşar.	1	2	3
8. Eşim bana gerçekten değer verir.	1	2	3

B8. PERCEIVED CONTROL AT HOME SCALE

Bu bölümde, ev aile hayatınıza ilişkin birtakım ifadeler yer almaktadır. Lütfen bu ifadelere ne derecede katıldığınızı belirtiniz. Değerlendirmenizi yaparken “hiç katılmıyorum” dan (1), “tamamen katılıyorum” a (5) doğru uzanan cevap seçeneklerini kullanınız. Düşüncelerinizi en uygun yansıtan rakamı daire içine alınız.

	Hiç Katılmıyorum	Biraz Katılmıyorum	Kararsızım	Biraz Katılıyorum	Tamamen Katılıyorum
1.Ev hayatımdaki önemli şeyleri değiştirebilmek için yapabileceğim çok az şey var.	1	2	3	4	5
2.Ev yaşantımla ilgili bazı sorunları çözmemin hiçbir yolu yok.	1	2	3	4	5
3.Ev yaşantım içerisinde bazen itilip kakıldığımı hissediyorum.	1	2	3	4	5
4.Evde başıma gelenlerle ilgili çok az kontrole sahibim.	1	2	3	4	5
5.Aile ve evle ilgili problemlerle baş etmede çoğunlukla kendimi çaresiz hissediyorum.	1	2	3	4	5
6.Evde hiçbir şey istediğim şekilde yürümüyor.	1	2	3	4	5
7.Ev ve aile yaşantımı istediğim doğrultuda sürdürme çabalarımın sonuçsuz kaldığını düşünüyorum.	1	2	3	4	5
8.Aile bireylerinin hayatlarındaki önemli kararlarda söz sahibi olduğumu düşünmüyorum.	1	2	3	4	5

B9. MOTIVATION TOWARD FAMILY SCALE

Aşağıda, ev/ aile hayatına yönelik bir takım aktiviteleri neden yaptığınıza dair ifadeler bulunmaktadır. Lütfen 1 (*Hiç Uygun Değil*)’den 5 (*Tamamen Uygun*)’a kadar derecelendirilmiş ölçeği kullanarak, her bir maddenin söz konusu aktiviteyi gerçekleştirme nedenlerinize ne derecede uyduğunu belirtiniz.

A. Evimle ilgili (*temizlik, ütü, yemek, tamirat, bakım, dekorasyon vb.*) işleri yapıyorum CÜNKÜ...

	Hiç uygun değil	Biraz Uygun değil	Kararsızım	Biraz Uygun	Tamamen Uygun
1. Bu tarz işlerle ilgilenmek bana eğlenceli geliyor.	1	2	3	4	5
2. Bu tarz işlerle uğraşmak benim için doğal bir alışkanlık haline geldi.	1	2	3	4	5
3. Bu ‘düzenli bir ev hayatı’ hedefime ulaşmamı sağlıyor.	1	2	3	4	5
4. Bu tarz işleri yapmak kendimi yeterli hissetmemi sağlıyor.	1	2	3	4	5
5. Eşimin/başkalarının bu tarz işleri becerebildiğini görmesini isterim.	1	2	3	4	5
6. Evimle ilgili bu tarz işleri yapmıyorum çünkü bu işler ile uğraşmanın zaman kaybı olduğunu düşünüyorum.	1	2	3	4	5

B. Çocuğumun/ Çocuklarımın eğitim ve öğrenimi (ödevlerine yardımcı olmak, okul ile ilgili sorunlarını dinlemek ve çözüm bulmaya çalışmak, çeşitli eğitimler almasını sağlamak, eğitim için gerekli kaynakları sağlamak vb.) ile kişisel olarak ilgileniyorum CÜNKÜ...

	Hiç uygun değil	Biraz Uygun değil	Kararsızım	Biraz Uygun	Tamamen Uygun
1.Bunları yaparken keyifli zaman geçiriyorum.	1	2	3	4	5
2.Bu bir 'ebeveyn' olarak yaşamımın bir parçası.	1	2	3	4	5
3.Bu 'iyi bir ebeveyn' olma hedefime ulaşmamı sağlıyor.	1	2	3	4	5
4.Eğer bunları yapmazsam kendimi suçlu hissedirim.	1	2	3	4	5
5.Eşim/başkaları benim bir 'ebeveyn' olarak bunları yapmamı bekliyor.	1	2	3	4	5
6.Çocuğumun/ Çocuklarımın eğitim ve öğrenimi ile ilgilenmiyorum çünkü bu işler ile uğraşmanın zaman kaybı olduğunu düşünüyorum.	1	2	3	4	5

C. Çocuğumun/ çocuklarımın gelişimine yönelik konularla (bakımı, fiziksel ve ruhsal durumu, genel sağlığı, tedavisi vb.) kişisel olarak ilgilenirim CÜNKÜ...

	Hiç uygun değil	Biraz Uygun değil	Kararsızım	Biraz Uygun	Tamamen Uygun
1.Bu bunları yapmaktan tatmin duyuyorum.	1	2	3	4	5
2.Bunları bir 'ebeveynin' doğal olarak yaptığı şeyler olarak görüyorum.	1	2	3	4	5
3.Bunlarla ilgilenmeyi kişisel olarak önemli buluyorum.	1	2	3	4	5
4.Eğer bunları yapmazsam kendimi suçlu hissedirim.	1	2	3	4	5
5.Eğer bunları yapmazsam ailem tarafından eleştirileceğimi düşünüyorum.	1	2	3	4	5
6. Çocuğumun/ çocuklarımın gelişimine yönelik konularla ilgileniyorum ancak bunun bana göre olmadığını düşünüyorum.	1	2	3	4	5

D. Çocuğumun/ çocuklarımla çeşitli sosyal aktivitelere (sinemaya gitmek, birlikte oyun oynamak, çocuğumun/çocuklarımla arkadaşları ile vakit geçirmek, birlikte seyahat etmek vb.) katılıyorum CÜNKÜ...

	Hiç uygun değil	Biraz Uygun değil	Kararsızım	Biraz Uygun	Tamamen Uygun
1. Bu, bana zevk veriyor.	1	2	3	4	5
2. Bunları bir 'ebeveynin' doğal olarak yaptığı şeyler olarak görüyorum.	1	2	3	4	5
3. Bunları yapmayı değerli buluyorum.	1	2	3	4	5
4. Bunları yapmak 'bir ebeveyn' olarak kendimle gurur duymamı sağlıyor.	1	2	3	4	5
5. Ailemin/Başkalarının bunları yaptığını görmesini isterim.	1	2	3	4	5
6. Çocuğumun/çocuklarımla çeşitli sosyal aktivitelere katılmıyorum çünkü bunlarla uğraşmanın zaman kaybı olduğunu düşünüyorum.	1	2	3	4	5

E. Eşimin huzurlu ve sağlıklı olmasını sağlamak (sorunlarını dinlemek, sorunlarına çözüm bulmaya çalışmak, fiziksel sağlığı ile ilgilenmek, tedavisine destek olmak vb.) ile kişisel olarak ilgileniyorum CÜNKÜ...

	Hiç uygun Değil	Biraz Uygun değil	Kararsızım	Biraz Uygun	Tamamen Uygun
1. Bunları yapmaktan tatmin duyuyorum.	1	2	3	4	5
2. Bunları bir 'eşin' doğal olarak yaptığı şeyler olarak görüyorum.	1	2	3	4	5
3. Bu 'iyi bir eş' olma hedefime ulaşmamı sağlıyor.	1	2	3	4	5
4. Bunlarla ilgilenmek bir 'eş' olarak kendimi yeterli hissetmemi sağlıyor.	1	2	3	4	5
5. Eğer bunları yapmazsam eşimin/başkalarının beni eleştireceğini düşünüyorum.	1	2	3	4	5
6. Eşimin huzurlu ve sağlıklı olmasını sağlamak ile ilgileniyorum ancak bu işler ile uğraşmak istemiyorum.	1	2	3	4	5

F. Eşim ile çeşitli sosyal aktivitelere (sinemaya gitmek, baş başa kalmak, eşimin arkadaşları ile vakit geçirmek, birlikte seyahat etmek vb.) katılıyorum **CÜNKÜ...**

	Hiç uygun Değil	Biraz Uygun değil	Kararsızım	Biraz Uygun	Tamamen Uygun
1.Bu bana eğlenceli geliyor.	1	2	3	4	5
2.Bu bir 'eş' olarak yaşamımın bir parçası.	1	2	3	4	5
3.Bunları yapmayı değerli buluyorum.	1	2	3	4	5
4.Eğer bunları yapmazsam kendimi suçlu hissederim.	1	2	3	4	5
5.Eşimin/başkalarının bunları yaptığını görmesini isterim.	1	2	3	4	5
6.Eşim ile çeşitli sosyal aktivitelere <u>katılmıyorum</u> çünkü bunlarla uğraşmanın zaman kaybı olduğunu düşünüyorum.	1	2	3	4	5

B10.FAMILY SATISFACTION SCALE

Aşağıda ailenize yönelik duygularınıza ilişkin bazı maddeler verilmiştir. Lütfen her bir Maddedeki ifadelere ne derecede katıldığınızı belirtiniz. Değerlendirmenizi yaparken “hiç katılmıyorum” dan (1), “tamamen katılıyorum” a (7) doğru uzanan cevap seçeneklerini kullanınız.

	Hiç katılmıyorum	Katılmıyorum	Biraz Katılmıyorum	Kararsızım	Biraz Katılıyorum	Katılıyorum	Tamamen katılıyorum
1. Ailem idealime büyük ölçüde yaklaşıyor.	1	2	3	4	5	6	7
2. Aile koşullarım mükemmel.	1	2	3	4	5	6	7
3. Ailemden memnunum.	1	2	3	4	5	6	7
4. Ailemde şu ana kadar istediğim önemli şeylere sahip oldum.	1	2	3	4	5	6	7
5. Ailemi bir daha seçseydim hiçbir şeyi değiştirmek istemezdim.	1	2	3	4	5	6	7

B11. EMOTIONAL EXHAUSTION AT HOME SCALE

Aşağıda evlilik/ aile hayatına yönelik duygularınızı birtakım ifadeler yer almaktadır. Lütfen her ifadeniştir belirttiği durumu ne sıklıkla yaşadığınızı belirtiniz. Değerlendirmenizi yaparken “hiçbir zaman” dan (0), “her zaman” a (4) doğru uzanan cevap seçeneklerini kullanarak, en uygun rakamı daire içine alınız.

	Hiç bir zaman	Nadiren	Bazen	Sık Sık	Her zaman
1. Evlilik hayatından soğuduğumu hissediyorum.	0	1	2	3	4
2. Eve yönelik işler ile uğraştığım bir günün sonunda kendimi ruhen tükenmiş hissediyorum.	0	1	2	3	4
3. Sabah kalktığımda bir gün daha bu ev hayatını kaldıramayacağımı hissediyorum.	0	1	2	3	4
4. Aile hayatımın beni kısıtladığını hissediyorum.	0	1	2	3	4
5. Evimin/ aile hayatımın düzenini sağlamak için çok fazla çalıştığımı hissediyorum.	0	1	2	3	4

B12. LIFE SATISFACTION SCALE

Aşağıda genel olarak yaşadığınız hayata yönelik duygularınıza ilişkin bazı maddeler verilmiştir. Lütfen her bir maddedeki ifadelere ne derecede katıldığınızı belirtiniz. Değerlendirmenizi yaparken “hiç katılmıyorum” dan (1), “tamamen katılıyorum” a (7) doğru uzanan cevap seçeneklerini kullanınız.

	Hiç Katılmıyorum	Katılmıyorum	Biraz Katılmıyorum	Kararsızım	Biraz Katılıyorum	Katılıyorum	Tamamen katılıyorum
1. Pek çok açıdan ideallerime yakın bir hayatım var.	1	2	3	4	5	6	7
2. Yaşam koşullarım mükemmel.	1	2	3	4	5	6	7
3. Yaşamım beni tatmin ediyor.	1	2	3	4	5	6	7
4. Şimdiye kadar yaşamımda istediğim önemli şeyleri elde ettim.	1	2	3	4	5	6	7
5. Hayatımı bir daha yaşama şansım olsaydı, hemen hemen hiç bir şeyi değiştirmezdim.	1	2	3	4	5	6	7

B13. ITEMS FOR DEMOGRAPHICS AND CONTROL VARIABLES

Yaşınız:.....

Cinsiyetiniz: Kadın Erkek

Eğitim Durumunuz:

Mesleğiniz:.....

Ne kadar süredir bu işte çalışıyorsunuz?.....

İş yerinizde esnek çalışma saatlerine sahip misiniz?.....

Ne kadar süredir evlisiniz?.....

Çocuklarınızın sayısı:.....

Lütfen çocuğunuzun/ çocuklarınızın yaşlarını belirtiniz.....

Çocuğunuzun/çocuklarınızın bakımı konusunda başkalarından herhangi bir destek (örn. bakıcı vb.) alıyor musunuz?

Evet Hayır

Evinizin düzenini sağlamak için dışarıdan herhangi bir destek (örn. temizlikçi vb.) alıyor musunuz?

Evet Hayır

B14. IDENTIFICATION WITH WORK
ROLE SCALE- MAIN STUDY

Aşağıda, iş yaşantısına ait genel tutum ve düşünceleri yansıtan maddeler verilmiştir. Lütfen her bir maddede ifade edilen görüşe ne oranda katıldığınıza karar veriniz. Değerlendirmenizi yaparken “hiç katılmıyorum” dan (1), “tamamen katılıyorum” a (5) doğru uzanan cevap seçeneklerini kullanınız ve uygun rakamı daire içine alınız.

	Hiç Katılmıyorum	Biraz Katılmıyorum	Kararsızım	Biraz Katılıyorum	Tamamen katılıyorum
1. Hayatımda meydana gelen en önemli şeyler işle ilgilidir.	1	2	3	4	5
2. İş, insanların zamanlarının çoğunu uğraşarak geçirmeleri gereken bir şeydir.	1	2	3	4	5
3. İş, insan yaşamının sadece küçük bir parçasıdır.	1	2	3	4	5
4. İş hayatın merkezi etkinliklerinden biri olarak kabul edilmelidir.	1	2	3	4	5
5. Bana göre, bir kişinin hayatındaki hedefler işi ile ilgili olmalıdır.	1	2	3	4	5
6. Yaşam, insanlar sadece işleriyle yoğun bir şekilde meşgul olduklarında yaşamaya değerdir.	1	2	3	4	5

**B15.IDENTIFICATION WITH FAMILY
ROLE SCALE-MAIN STUDY**

Aşağıda, aile yaşantısına ait genel tutum ve düşünceleri yansıtan maddeler verilmiştir. Lütfen her bir maddede ifade edilen görüşe ne oranda katıldığınıza karar veriniz. Değerlendirmenizi yaparken “hiç katılmıyorum” dan (1), “tamamen katılıyorum”a (5) doğru uzanan cevap seçeneklerini kullanınız ve uygun rakamı daire içine alınız.

	Hiç Katılmıyorum	Biraz Katılmıyorum	Kararsızım	Biraz Katılıyorum	Tamamen katılıyorum
1. Hayatımda meydana gelen en önemli şeyler aile ile ilgilidir.	1	2	3	4	5
2. Aile, insanların zamanlarının çoğunu uğraşarak geçirmeleri gereken bir şeydir.	1	2	3	4	5
3. Aile, insan yaşamının sadece küçük bir parçasıdır.	1	2	3	4	5
4. Aile yaşamı, hayatın merkezi etkinliklerinden biri olarak kabul edilmelidir.	1	2	3	4	5
5. Bana göre, bir kişinin hayatındaki hedefleri ailesi ile ilgili olmalıdır.	1	2	3	4	5
6. Yaşam, insanlar sadece aileleriyle yoğun bir şekilde meşgul olduklarında yaşamaya değerlidir.	1	2	3	4	5

C1. EXPLANATORY FACTOR ANALYSIS RESULTS FOR WORK-FAMILY CONFLICT SCALE

Scale Items	Factor 1	Factor 2
W-to F		
1. İşimin yarattığı stres aileme karşı olan görevlerimi yerine getirmemi zorlaştırmaktadır.	.84	
2. İşime harcadığım zaman aileme karşı sorumluluklarımı yerine getirmemi zorlaştırmaktadır.	.88	
3. İşimin bana yüklediği sorumluluklardan dolayı aileme ilgili yapmak istediğim bazı şeyleri yapamıyorum.	.90	
4. İşim yüzünden, ailece yaptığımız planlar değiştirmek zorunda kalırım.	.83	
5. İşimle ilgili sorumluluklarım aile hayatımı etkiliyor.	.85	
F-to-W		
6. Aileme ilgili sıkıntılarım, iş performansımı olumsuz etkiler.		.60
7. Aileme ayrımam gereken zaman nedeniyle, işlerimi ertelediğim olur.		.69
8. Ailemin ya da eşimin talepleri, işimi etkilemektedir.		.82
9. Aile hayatım yüzünden işimdeki temel sorumluluklarım aksayabiliyor.		.82
10. Ailemin ya da eşimin taleplerinden dolayı işimle ilgili olarak yapmak istediğim bazı şeyleri yapamam.		.81
Eigenvalue:	4.47	2.24
Explained Variance:	44.73%	22.38%

C2.EXPLANATORY FACTOR ANALYSIS
RESULTS FOR WEIMS SCALE AND EXCLUDED ITEMS

Scale Items	Factor 1	Factor 2	Factor 3
Intrinsic Motivation			
4. Yeni şeyler öğrenmekten oldukça keyif aldığım için.	.64		
5. Çünkü bu iş kim olduğumun önemli bir parçası haline geldi.	.68		
7. Kariyer hedeflerime ulaşmak için.	.69		
8. İlginç zorluklarla mücadele etmekten aldığım tatmin için.	.71		
10. Çünkü bu iş, hayatımı yaşamak için seçmiş olduğum yolun bir parçası.	.47		
14. Çünkü bu iş, hayatımdaki önemli hedeflere ulaşmak için seçtiğim bir iş çeşidi.	.70		
15. Yapılması zor olan işlerde başarılı olmaktan aldığım keyif için.	.75		
18. Çünkü bu iş hayatımın bir parçası.	.60		
Extrinsic Motivation			
1. Belirli bir yaşam standardı sağladığı için.		-.69	
2. Bana kazandırdığı gelir için.		-.90	
9. Para kazanmamı sağladığı için.		-.71	
16. Çünkü bu çeşit bir iş bana güvence sağlıyor.	.40	-.44	
Amotivation			
3. Bu soruyu ben de kendime soruyorum, bu işe dair önemli görevleri yerine getiremiyorum gibi görünüyor.			.46
12. Nedenini ben de bilmiyorum, hiç de gerçekçi olmayan şartlar altında çalışıyoruz.			.63
17. Bilmiyorum, bizden çok fazla şey bekleniyor.			.60
Eigenvalue:	4.52	2.30	1.59
Explained Variance:	30.11%	15.31%	10.57%

*;cross-loaded item

EXCLUDED ITEMS

- | |
|---|
| <p>6. Çünkü bu işte başarılı olmak istiyorum, eğer olamazsam kendimden oldukça utanç duyarım.
11. Bu işte çok iyi olmak istediğim için, aksi halde büyük bir hayal kırıklığı yaşarım.
13. Çünkü bu hayatta kazanan olmak istiyorum.</p> |
|---|

C3. EXPLANATORY FACTOR ANALYSIS RESULTS FOR JOB DIAGNOSTIC SURVEY

Scale Items	F1	F 2	F3	F4	F5
Task Identity					
2.İşiniz ne ölçüde kendi içinde bir bütündür? Yani, yaptığınız şey belirli bir başı ve sonu olan bütün bir iş midir? Yoksa başkaları ve ya otomatik makineler tarafından bitirilen bir işin sadece küçük bir parçası mıdır? *	.36		.55		
7. İşim bir bütün işi başından sonuna kadar yapmaya olanak tanıyacak biçimde düzenlenmiştir.	.74				
8. İşimin gerektirdiklerini yapmak başarımlı belirlemek açısından birçok imkan sağlar.**	.54				
12. İşim başladığım iş bölümlerini tamamen bitirmeme olanak sağlar.	.76				
Task Significance					
4. Genel olarak, işiniz ne derece önemli ve anlamlıdır? Yani, yaptığınız işin sonucu insanların hayatlarını veya durumlarını önemli derecede etkiler mi?		.72			
10. İşimin nasıl yapıldığı birçok kişiyi etkiler.		.66			
15 İşim burada yapılan işlerin toplamı düşünüldüğünde, çok önemli ve anlamlı değildir. *		.61			.52
Autonomy					
1. İşinizi nasıl yapacağınıza ne derece kendiniz karar verebilirsiniz?			.70		
11. İşim kişisel inisiyatifimi veya yargımı kullanmama asla imkan tanımaz. *			.55		.37
14. İşimi nasıl yapacağım konusunda bağımsızlık ve özgürlüğüm vardır			.74		

*cross-loaded items; **; although these items loaded on different factors, they were evaluated own dimensions.

Scale Items	F1	F 2	F3	F 4	F5
Skill Variety					
3. İşinizde ne derece çeşitlilik vardır? Yani, işiniz çeşitli beceri ve yetenekleri kullanarak birçok değişik şey yapmayı ne ölçüde gerektirir? *		.32		.65	
6. İşim bir dizi karmaşık ve yüksek düzeyde beceri kullanmayı gerektirir.*		.44		.57	
5. Performansınızın iyi olup olmadığına yönelik bilgiyi işin kendisinden almak ne derece mümkündür? Yani işinizin kendisi, amirlerinizin veya mesai arkadaşlarınızın sağlayabileceği bilgiden başka başarılı olup olmadığınız konusunda ne kadar ipucu sağlar? **				.64	
9. İşim oldukça basit ve tekrarlanan bir niteliktedir.*		-.36			.59
13. İşim ne derece başarılı olduğum konusunda bana çok az ipucu sağlar.					.73
Eigenvalue:	3.81	1.52	1.29	1.07	1.01
Explained Variance:	25.42%	10.12%	8.59%	7.11%	6.76%

*cross-loaded items; **, although these items loaded on different factors, they were evaluated own dimensions

C4. EXPLANATORY FACTOR ANALYSIS RESULTS FOR WORK SUPPORT SCALE

Scale Items	Factor 1	Factor 2
Supervisory Support		
1. Amirim iřteki sorunlarım ya da isteklerime ilgi gsterir.	.86	
2. Amirim tarafından deęer grdüğümü hissedirim.	.91	
3. Amirim bana karřı yakın ve sıcaktır.	.89	
Coworker Support		
4. Lazım olduęunda iř arkadaşlarımdan yardım isteyebilirim.		.82
5. İřte zorluklarla karřılařtıęımda iř arkadaşlarımdan bana destek olacaęına gvenirim.		.91
6. İř arkadaşlarımdan beni deęerli bulduęunu hissediyorum.*	.31	.77
Eigenvalue:	3.51	1.23
Explained Variance:	58.48%	20.51%

*; cross-loaded item

**C5. EXPLANATORY FACTOR ANALYSIS RESULTS
FOR EMOTIONAL EXHAUSTION AT WORK SCALE**

Job Exhaustion	Factor 1
1. İşimden soğuduğumu hissediyorum.	.76
2. İş dönüşü ruhen tükenmiş hissediyorum.	.82
3. Sabah kalktığımda bir gün daha bu işi kaldıramayacağımı düşünüyorum.	.84
4. İşimin beni kısıtladığını hissediyorum.	.75
5. İşimde çok fazla çalıştığımı hissediyorum.	.60
Eigenvalue:	2.87
Explained Variance:	57.38%



C6. EXPLANATORY FACTOR ANALYSIS RESULTS FOR JOB SATISFACTION SCALE

Job Satisfaction	Factor 1
1. Genel olarak konuşmak gerekirse, bu iş beni çok tatmin ediyor.	.88
2. Bu işte yaptığım çalışmalar, genel olarak, beni tatmin ediyor.	.88
3. Genel olarak konuşmak gerekirse, işimi seviyorum.	.87
4. Kunin Yüz İfadesi	.80
Eigenvalue:	2.95
Explained Variance:	73.78%

C7. EXPLANATORY FACTOR ANALYSIS RESULTS FOR SPOUSAL SUPPORT SCALE

Spousal Support	Factor 1
1. Eşim bana hoş espriler yapar.	.72
2. Eşim yaptıklarımı destekler.	.73
3. Eşim benimle olmak için zaman yaratmaya çalışır.	.81
4. Eşim bana sarılır, üzerime titrer.	.88
5. Eşim bana yanımda olduğunu hissettirir.	.89
6. Eşim bana şefkat gösterir.	.92
7. Eşim beni sever, okşar.	.90
8. Eşim bana gerçekten değer verir.	.87
Eigenvalue:	5.68
Explained Variance:	71.02%

C8. EXPLANATORY FACTOR ANALYSIS RESULTS FOR PERCEIVED CONTROL AT HOME SCALE

Powerlessness	Factor 1
1.Ev hayatımdaki önemli şeyleri değiştirebilmek için yapabileceğim çok az şey var.	.63
2.Ev yaşantımla ilgili bazı sorunları çözmemin hiçbir yolu yok.	.75
3.Ev yaşantım içerisinde bazen itilip kakıldığımı hissediyorum.	.73
4.Evde başıma gelenlerle ilgili çok az kontrole sahibim.	.78
5.Aile ve evle ilgili problemlerle baş etmede çoğunlukla kendimi çaresiz hissediyorum.	.81
6.Evde hiçbir şey istediğim şekilde yürütüyor.	.82
7.Ev ve aile yaşantımı istediğim doğrultuda sürdürme çabalarımın sonuçsuz kaldığını düşünüyorum.	.84
8.Aile bireylerinin hayatlarındaki önemli kararlarda söz sahibi olduğumu düşünmüyorum.	.56
Eigenvalue:	4.44
Explained Variance:	55.48%

**C9. EXPLANATORY FACTOR ANALYSIS RESULTS FOR
MOTIVATION TOWARD FAMILY SCALE AND EXCLUDED ITEMS**

Scale Items	Factor 1	Factor 2	Factor 3
Intrinsic Motivation			
7. Bunları yaparken keyifli zaman geçiriyorum.	.46		
19. Bu, bana zevk veriyor.	.82		
21. Bunları yapmayı değerli buluyorum.	.87		
31. Bu bana eğlenceli geliyor.	.47		
32. Bu bir 'eş' olarak yaşamımın bir parçası.	.48		
Extrinsic Motivation			
5. Eşimin/başkalarının bu tarz işleri becerebildiğini görmesini isterim.		.50	
10. Eğer bunları yapmazsam kendimi suçlu hissederim.		.41	
11. Eşim/başkaları benim bir 'ebeveyn' olarak bunları yapmamı bekliyor		.64	
17. Eğer bunları yapmazsam ailem tarafından eleştirileceğimi düşünüyorum.		.73	
23. Ailemin/Başkalarının bunları yaptığını görmesini isterim.		.76	
29. Eğer bunları yapmazsam eşimin/başkalarının beni eleştireceğini düşünüyorum.		.74	
35. Eşimin/başkalarının bunları yaptığını görmesini isterim.		.72	
Amotivation			
12. Çocuğumun/ Çocuklarımla eğitim ve öğrenimi ile <i>ilgileneceklerim</i> çünkü bu işler ile uğraşmanın zaman kaybı olduğunu düşünüyorum.			.80
18. Çocuğumun/ çocuklarımla gelişimine yönelik konularla ilgileniyorum ancak bunun bana göre olmadığını düşünüyorum.			.56
24. Çocuğumun/çocuklarımla çeşitli sosyal aktivitelere <i>katılmıyorum</i> çünkü bunlarla uğraşmanın zaman kaybı olduğunu düşünüyorum.			.83
30. Eşimin huzurlu ve sağlıklı olmasını sağlamak ile ilgileniyorum ancak bu işler ile uğraşmak istemiyorum.			.49
36. Eşim ile çeşitli sosyal aktivitelere <i>katılmıyorum</i> çünkü bunlarla uğraşmanın zaman kaybı olduğunu düşünüyorum.			.63
Eigenvalue:	4.08	4.04	1.58
Explained Variance:	18.36%	18.28%	5.98%

EXCLUDED ITEMS

6. Evimle ilgili bu tarz işleri <u>yapmıyorum</u> çünkü bu işler ile uğraşmanın zaman kaybı olduğunu düşünüyorum.
8. Bu bir 'ebeveyn' olarak yaşamımın bir parçası.
9. Bu 'iyi bir ebeveyn' olma hedefime ulaşmamı sağlıyor.
13. Bunları yapmaktan tatmin duyuyorum.
14. Bunları bir 'ebeveynin' doğal olarak yaptığı şeyler olarak görüyorum.
15. Bunlarla ilgilenmeyi kişisel olarak önemli buluyorum.
16. Eğer bunları yapmazsam kendimi suçlu hissederim.
20. Bunları bir 'ebeveynin' doğal olarak yaptığı şeyler olarak görüyorum.
22. Bunları yapmak 'bir ebeveyn' olarak kendimle gurur duymamı sağlıyor.
27. Bu 'iyi bir eş' olma hedefime ulaşmamı sağlıyor.
28. Bunlarla ilgilenmek bir 'eş' olarak kendimi yeterli hissetmemi sağlıyor.
33. Bunları yapmayı değerli buluyorum.
34. Eğer bunları yapmazsam kendimi suçlu hissederim.

**C10.EXPLANATORY FACTOR ANALYSIS RESULTS FOR EMOTIONAL
EXHAUSTION AT HOME SCALE**

Emotional Exhaustion at Home	Factor 1
1. Evlilik hayatından soğuduğumu hissediyorum.	.74
2. Eve yönelik işler ile uğraştığım bir günün sonunda kendimi ruhen tükenmiş hissediyorum.	.82
3. Sabah kalktığımda bir gün daha bu ev hayatını kaldıramayacağımı hissediyorum.	.79
4. Aile hayatımın beni kısıtladığını hissediyorum.	.78
5. Evimin/ aile hayatımın düzenini sağlamak için çok fazla çalıştığımı hissediyorum.	.68
Eigenvalue:	2.91
Explained Variance:	58.12%

**C11. EXPLANATORY FACTOR ANALYSIS RESULTS FOR FAMILY
SATISFACTION SCALE**

Family Satisfaction	Factor 1
1. Ailem idealime büyük ölçüde yaklaşıyor.	.84
2. Aile koşullarım mükemmel.	.85
3. Ailemden memnunum.	.88
4. Ailemde şu ana kadar istediğim önemli şeylere sahip oldum.	.82
5. Ailemi bir daha seçseydim hiçbir şeyi değiştirmek istemezdim.	.83
Eigenvalue:	3.51
Explained Variance:	71.31%

**C12. EXPLANATORY FACTOR ANALYSIS RESULTS FOR LIFE
SATISFACTION SCALE**

Life Satisfaction	Factor 1
1. Pek çok açıdan ideallerime yakın bir hayatım var.	.88
2. Yaşam koşullarım mükemmel.	.89
3. Yaşamım beni tatmin ediyor.	.90
4. Şimdiye kadar yaşamımda istediğim önemli şeyleri elde ettim.	.88
5. Hayatımı bir daha yaşama şansım olsaydı, hemen hemen hiç bir şeyi değiştirmedim.	.83
Eigenvalue:	3.83
Explained Variance:	76.07%



D1.CONFIRMATORY FACTOR ANALYSIS RESULTS FOR WORK-FAMILY CONFLICT SCALE

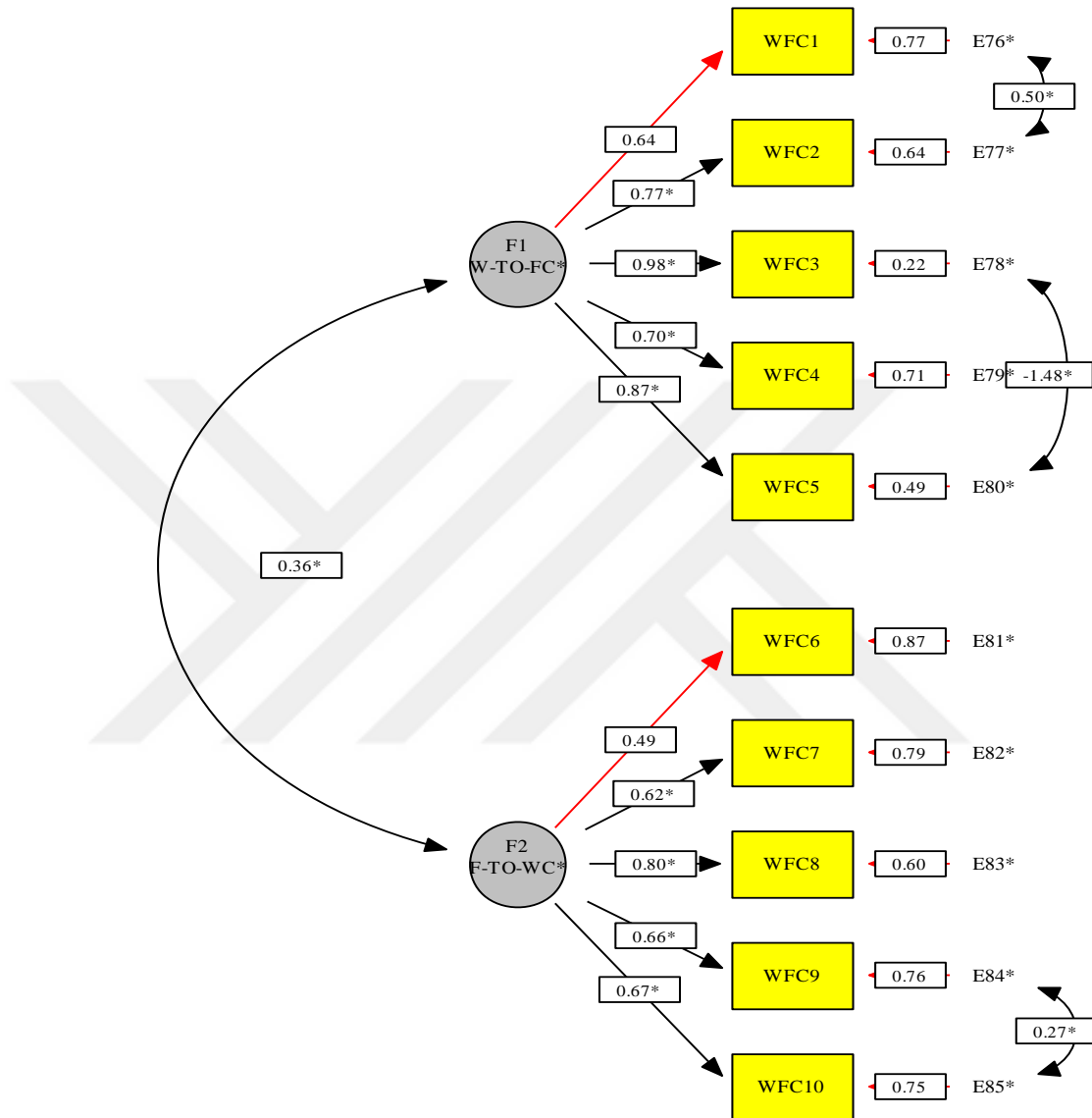

$\chi^2(31, 405) = 102.53, p < .001, (\chi^2 / \text{d.f. ratio} = 3.31), \text{CFI} = .96, \text{GFI} = .95, \text{NFI} = .95, \text{SRMR} = .07, \text{RMSEA} = .08, 90\% \text{ C.I.} = .06, .09$

D2. CONFIRMATORY FACTOR ANALYSIS RESULTS FOR WEIMS SCALE AND EXCLUDED ITEMS

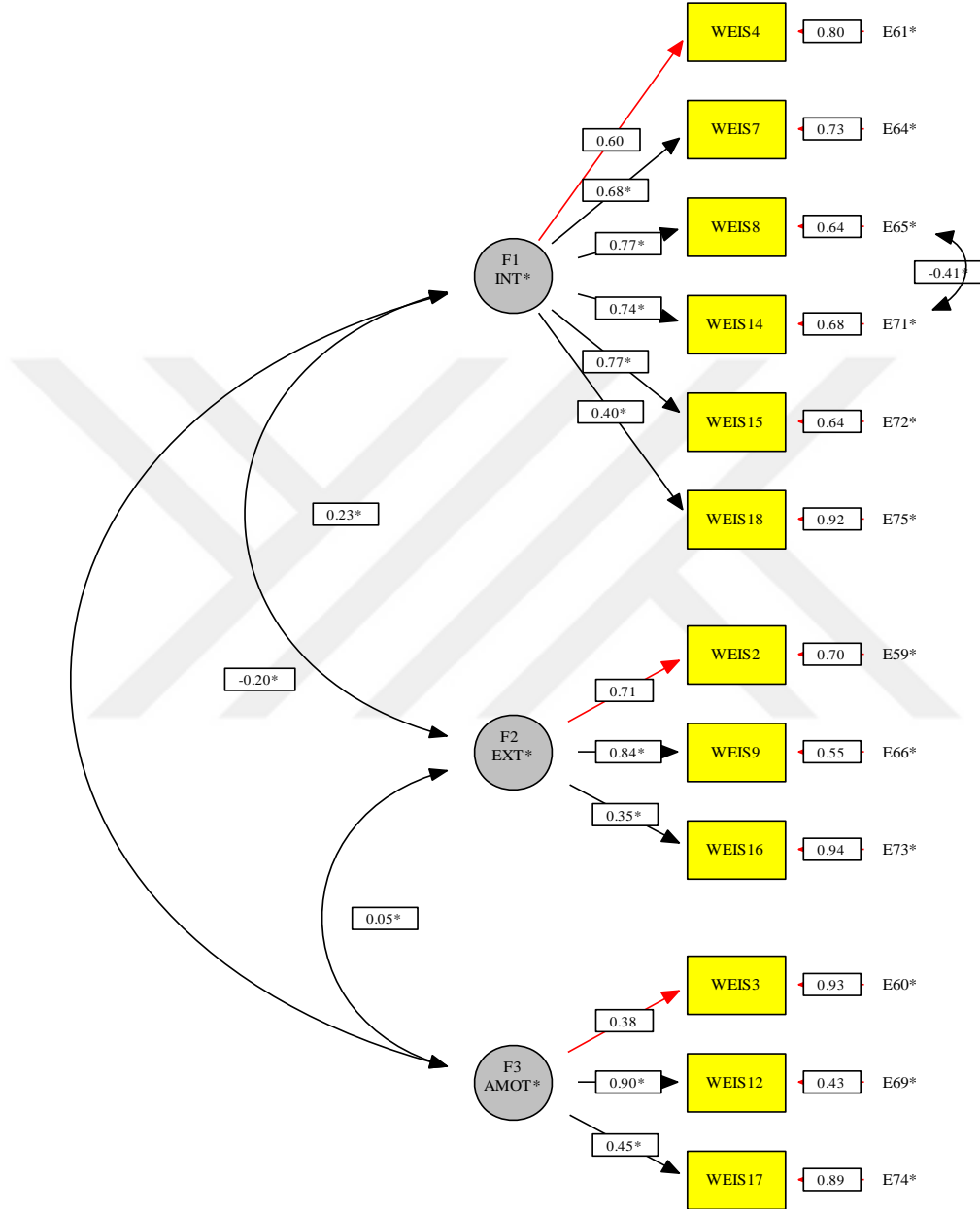

$\chi^2(49, 405) = 121.79, p < .001$ ($\chi^2/\text{d.f. ratio} = 2.48$), CFI = .94, GFI = .95, NFI = .90, SRMR = .05, RMSEA = .06, 90% C.I. = .05, .08.

EXCLUDED ITEMS

5. Çünkü bu iş kim olduğumun önemli bir parçası haline geldi.
10. Çünkü bu iş, hayatımı yaşamak için seçmiş olduğum yolun bir parçası.

D3.CONFIRMATORY FACTOR ANALYSIS RESULTS FOR JOB DIAGNOSTIC SURVEY AND EXCLUDED ITEMS

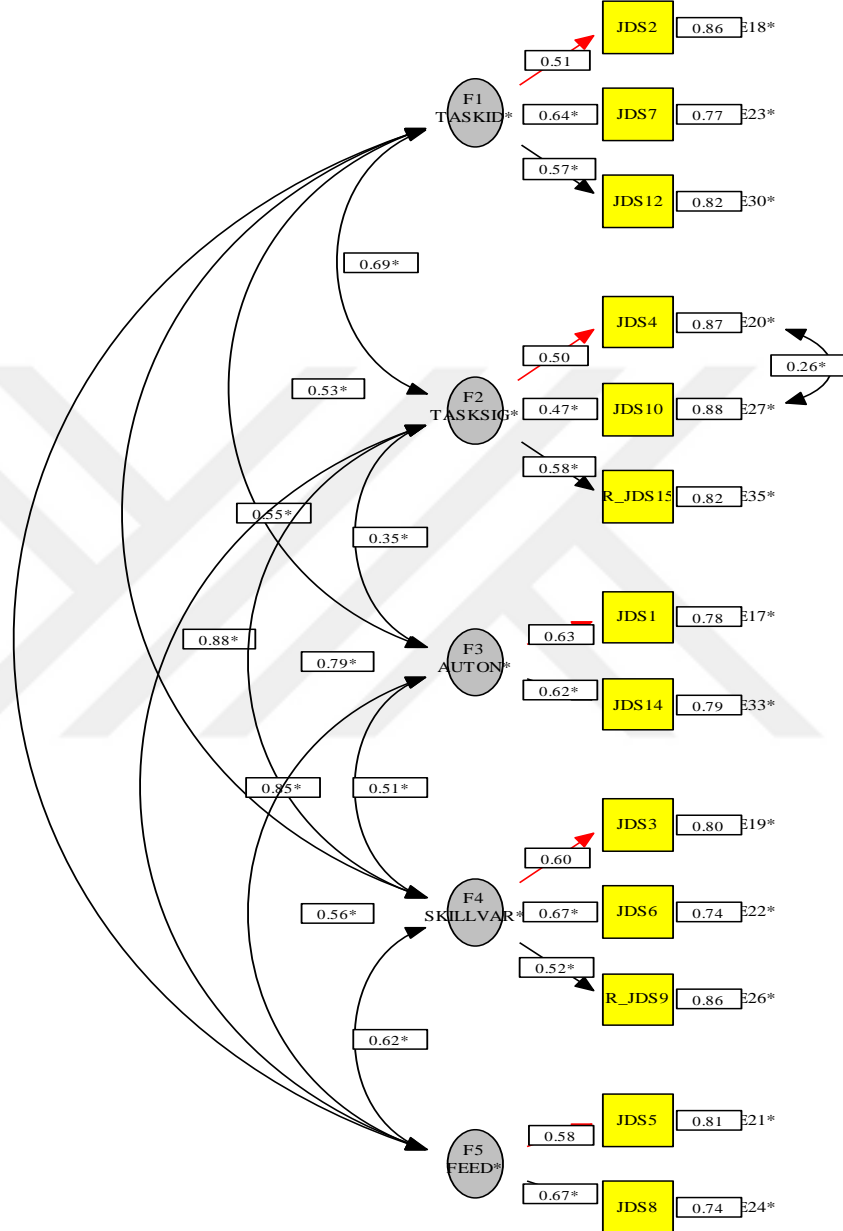

$\chi^2(54, 405) = 97.26$ $p < .001$ (χ^2 / d.f. ratio = 1.80), CFI = .95, GFI = .96, NFI = .90, SRMR = .04, RMSEA = .05, 90% C.I. = .03, .06.

EXCLUDED ITEMS

11. İşim kişisel inisiyatifimi veya yargımı kullanmama asla imkan tanımaz.
13. İşim ne derece başarılı olduğum konusunda bana çok az ipucu sağlar.

D4. CONFIRMATORY FACTOR ANALYSIS RESULTS FOR WORK SUPPORT SCALE

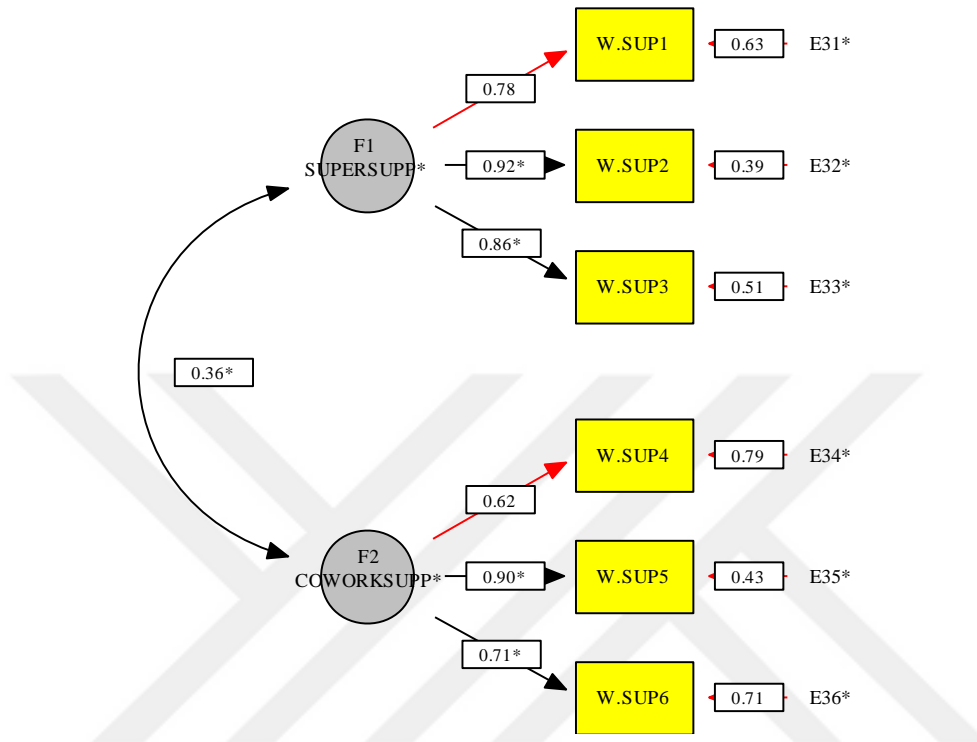

$\chi^2 (8, 405) = 26.84, p < .001$ ($\chi^2 / \text{d.f. ratio} = 3.35$), CFI = .98, GFI = .98, NFI = .98, SRMR = .04, RMSEA = .08, 90% C.I. = .05, .11

**D5. CONFIRMATORY FACTOR ANALYSIS RESULTS
FOR EMOTIONAL EXHAUSTION AT WORK SCALE**

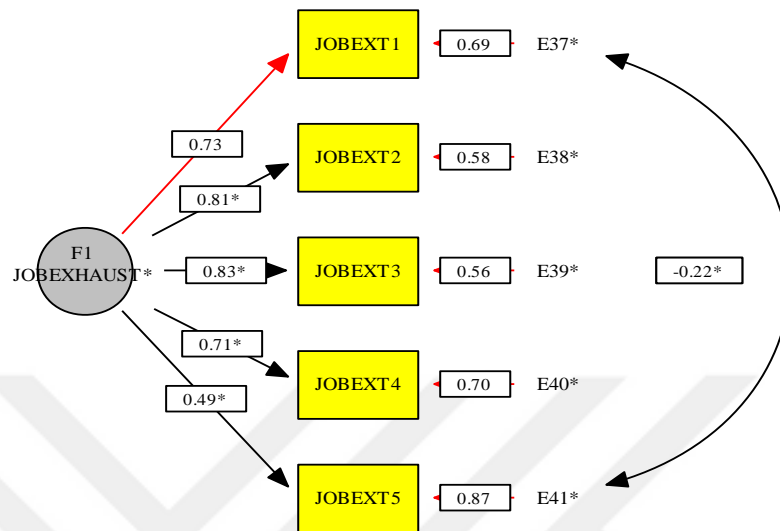

$\chi^2 (4, 405) = 7.62, p > .10, CFI = 1.00, GFI = .99, NFI = .99, SRMR = .02, RMSEA = .05, 90\% \text{ C.I.} = .00 \text{ to } .10$

D6. CONFIRMATORY FACTOR ANALYSIS RESULTS FOR JOB SATISFACTION SCALE

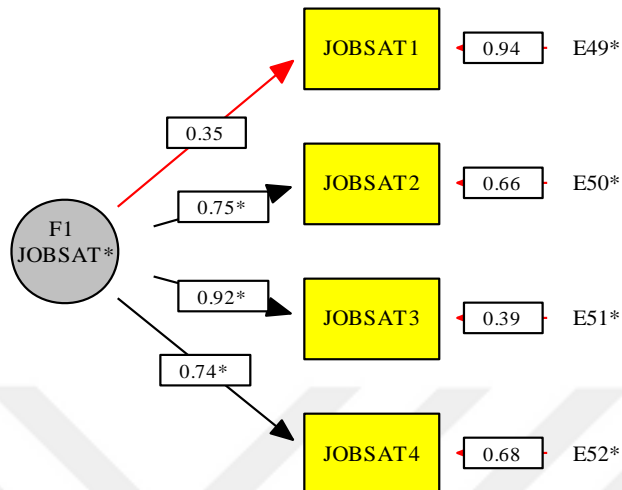

$\chi^2 (2, 405) = 6.40, p < .05, CFI = .99, GFI = .99, NFI = .99, SRMR = .02, RMSEA = .07, 90\% C.I. = .01, .14$

**D7. CONFIRMATORY FACTOR ANALYSIS RESULTS FOR
IDENTIFICATION WITH WORK ROLE SCALE AND
THE EXCLUDED ITEM**

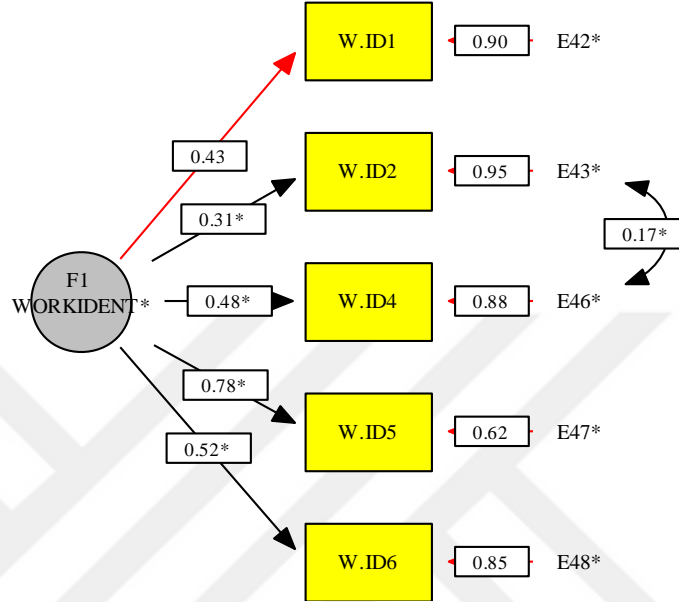

$\chi^2(4, 405) = 7.58, p > .10, CFI = .98, GFI = .99, NFI = .97, SRMR = .03, RMSEA = .05, 90\% C.I. = .00, .10$

THE EXCLUDED ITEM

3. İş, insan yaşamının sadece küçük bir parçasıdır.

**D8. CONFIRMATORY FACTOR ANALYSIS RESULTS
FOR SPOUSAL SUPPORT SCALE**

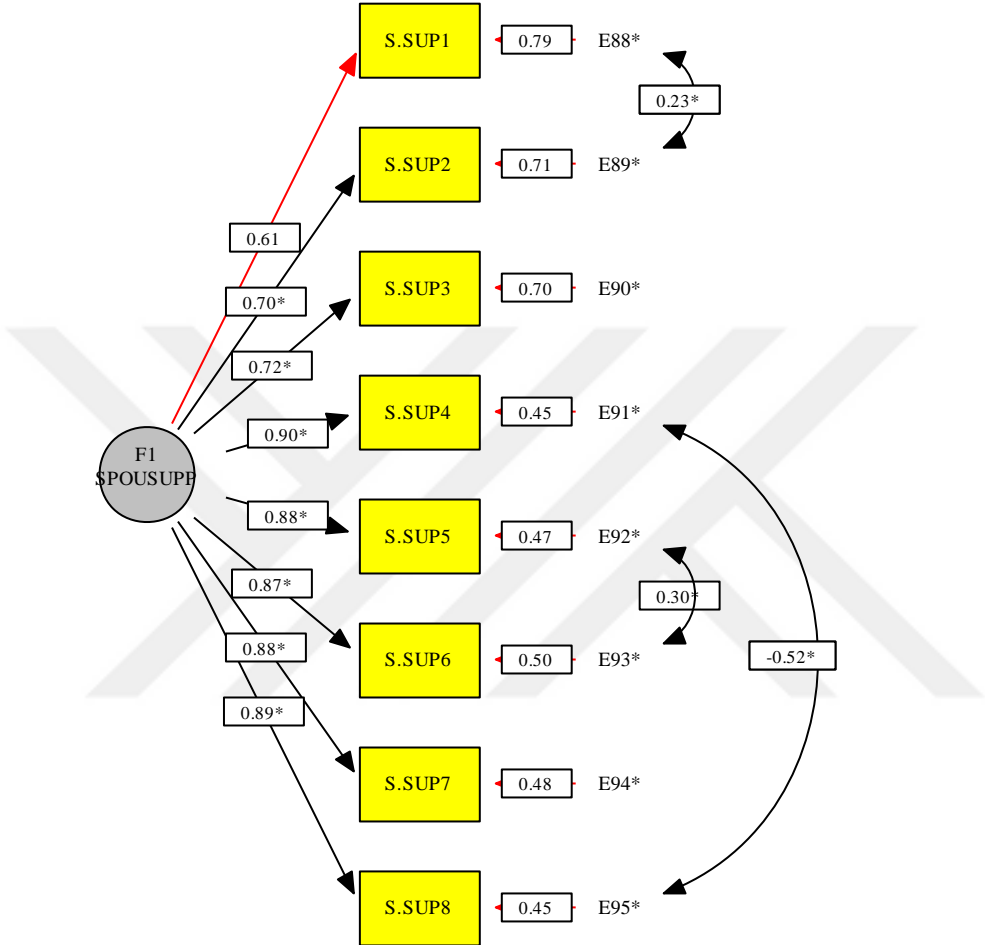

$\chi^2(17, 405) = 64.96, p = .00$ ($\chi^2/\text{d.f. ratio} = 3.82$), CFI = .98, GFI = .96, NFI = .98, SRMR = .02, RMSEA = .08, 90% C.I. = .06, .011.

D9. CONFIRMATORY FACTOR ANALYSIS RESULTS FOR PERCEIVED CONTROL AT HOME SCALE

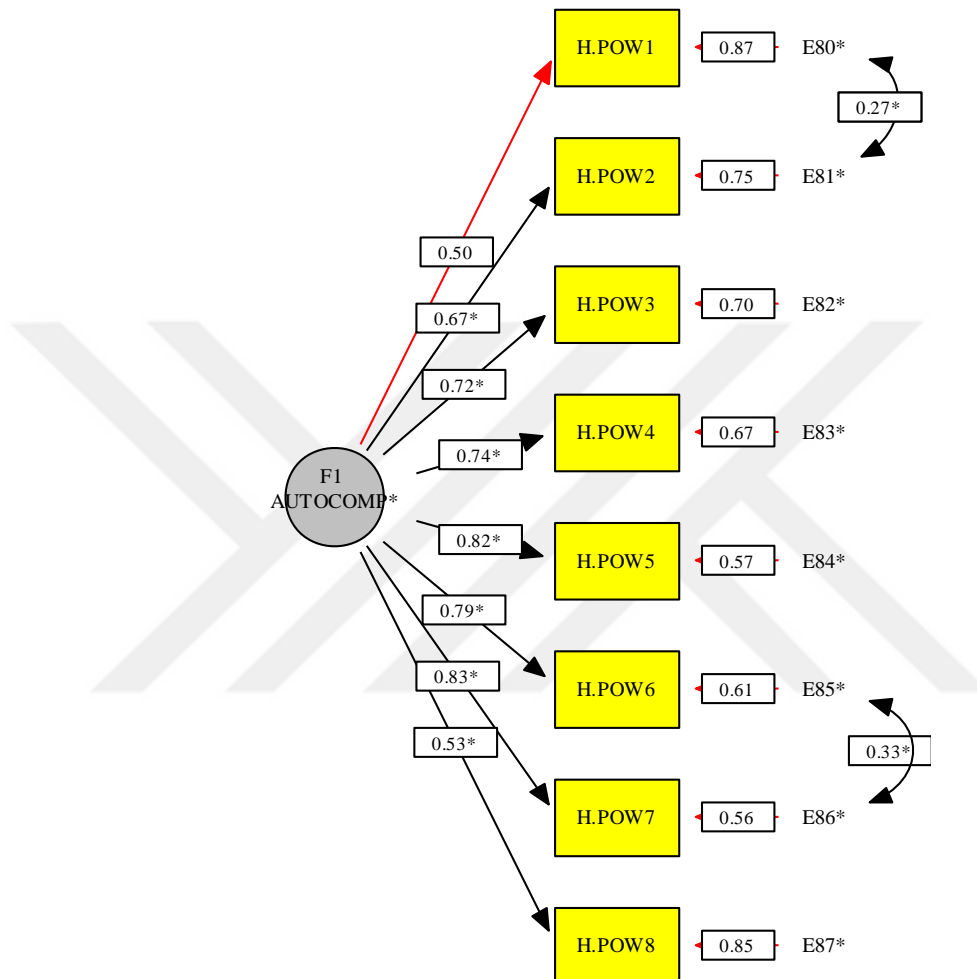

$\chi^2 (18, 405) = 48.1, p < .001$ ($\chi^2/d.f.$ ratio = 2.67), CFI = .98, GFI = .97, NFI = .97, SRMR = .03, RMSEA = .06, 90% C.I. = .04, .09

**D10. CONFIRMATORY FACTOR ANALYSIS RESULTS FOR
MOTIVATION TOWARD FAMILY SCALE AND EXCLUDED ITEMS**

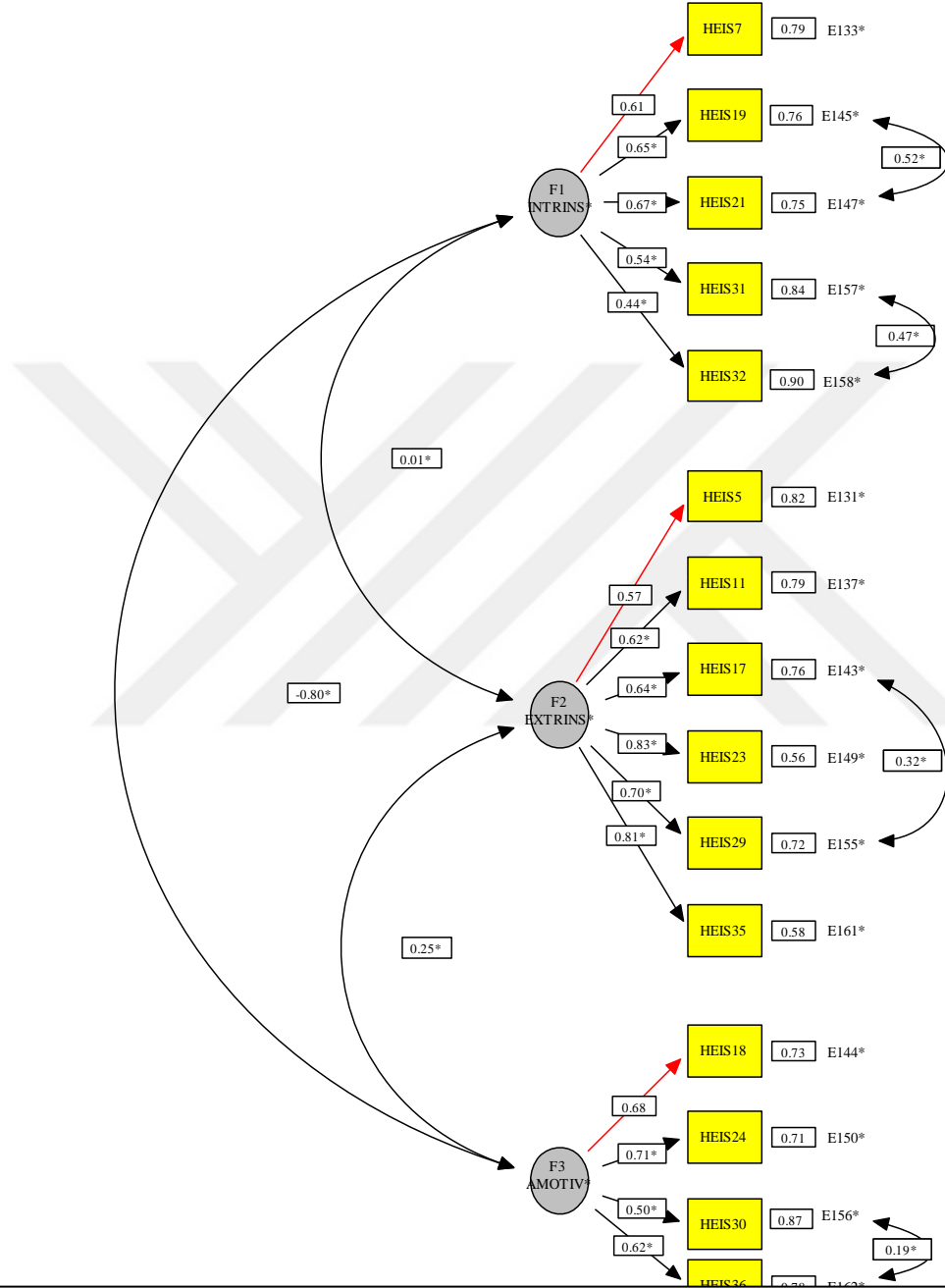

S-B χ^2 (83, 405) = 206.81, $p = .00$, (χ^2 /d.f. ratio=2.49), Roboust CFI= .91, GFI= .92, NFI= .86, SRMR= .06. RMSEA= .06. 90% C.I. = .05. .07.

EXCLUDED ITEMS

10. Eğer bunları yapmazsam kendimi suçlu hissederim.
12. Çocuğumun/ Çocuklarının eğitim ve öğrenimi ile ilgilenmiyorum çünkü bu işler ile uğraşmanın zaman kaybı olduğunu düşünüyorum.

**D11. CONFIRMATORY FACTOR ANALYSIS RESULTS FOR
EMOTIONAL EXHAUSTION AT HOME SCALE**

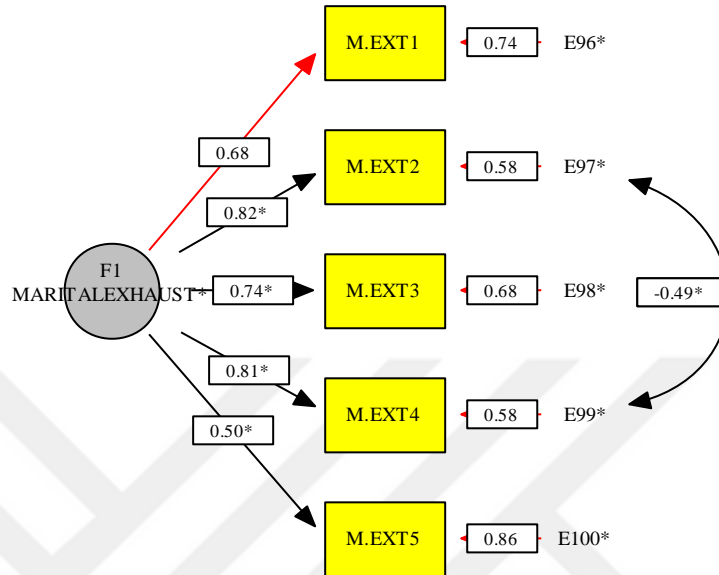

$\chi^2 (4, 405) = 15.52, p = .00$ ($\chi^2/d.f.$ ratio = 3.88), CFI = .98, GFI = .98, NFI = .98, SRMR = .03, RMSEA = .08. 90% C.I. = .04, .013.

D12.CONFIRMATORY FACTOR ANALYSIS RESULTS FOR FAMILY SATISFACTION SCALE

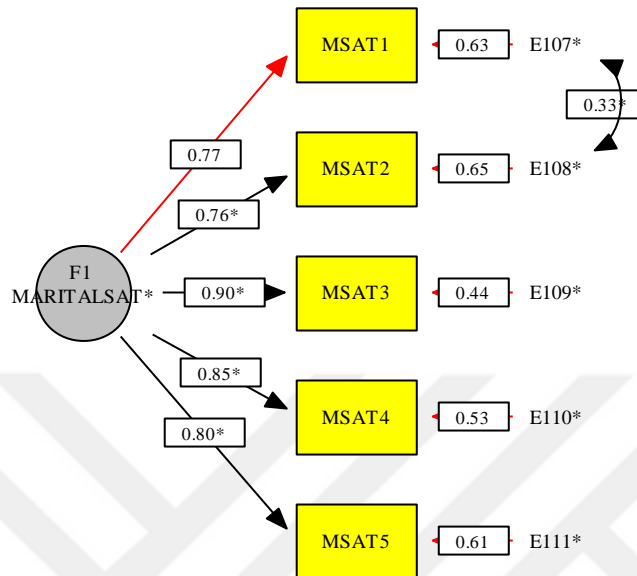

S-B χ^2 (10, 405) = 4.91, $p > .10$, CFI= 1.00, GFI= .99, NFI= .99, SRMR= .01, RMSEA= .02, 90% C.I. = .00, .08

**D13. CONFIRMATORY FACTOR ANALYSIS RESULTS FOR
IDENTIFICATION WITH FAMILY ROLE SCALE
AND THE EXCLUDED ITEM**

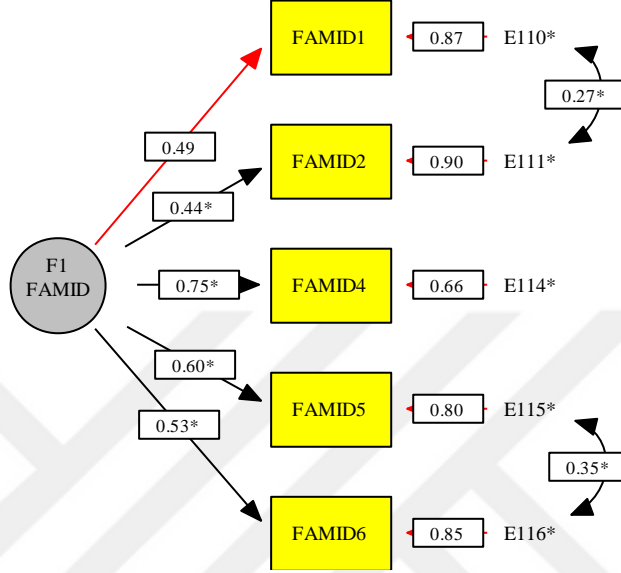

$\chi^2(3, 405) = 4.89, p > .10, CFI = 1.00, GFI = 1.00, NFI = .99, SRMR = .02, RMSEA = .06, 90\% C.I. = .00, .11$

THE EXCLUDED ITEM

3. Aile, insan yaşamının sadece küçük bir parçasıdır.

**D14. CONFIRMATORY FACTOR ANALYSIS RESULTS
FOR LIFE SATISFACTION SCALE**

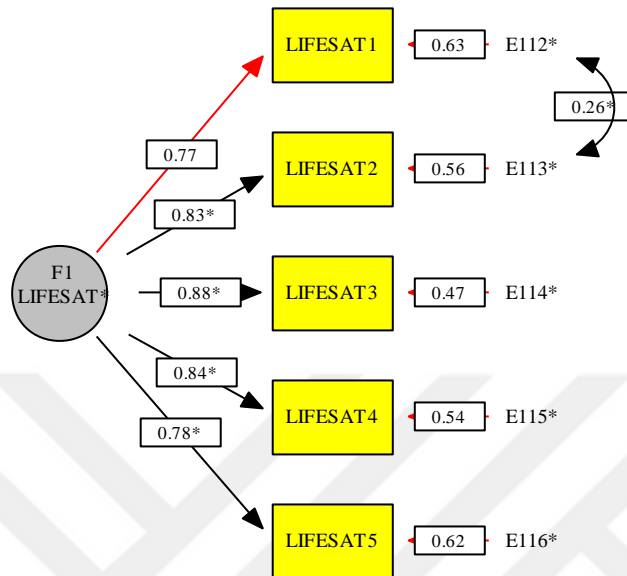

$\chi^2 (4, 405) = 8.21, p = .08, CFI = 1.00, GFI = .99, NFI = .99, SRMR = .01, RMSEA = .05, 90\% C.I. = .00, .10$

E. CURRICULUM VITAE

PERSONAL INFORMATION

Surname, Name: Yalçın, Aslı
Nationality: Turkish (TC)
Date and Place of Birth: October 7, 1983 Aydın
Phone: +90 233 14 54
e-mail: asliyalcin@cankaya.edu.tr

EDUCATION

2010-2017 Ph.D., Middle East Technical University (METU), Institute of Social Sciences, Social Psychology Ph.D. Program
2007–2010 M.Sc., Middle East Technical University (METU), Institute of Social Sciences, Industrial and Organizational Psychology M.Sc. Program
2003–2006 B.S., Middle East Technical University (METU), Department of Psychology (Minor)
2001–2006 B.S., Middle East Technical University (METU), Department of Psychology (Major)

WORK EXPERIENCE

Year	Place	Enrollment
2013- Present	Çankaya University, Ankara	Instructor
2010- 2013	Ufuk University, Ankara	Research Assistant

COURSES GIVEN

Çankaya University, Department of Psychology (Undergraduate)
PHIL 102- Introduction to Philosophy
PSY 101- Introduction to Psychology I
PSY 102- Introduction to Psychology II
PSY 113- Research Methods I
PSY 251- Social Psychology I
PSY 252- Social Psychology II
PSY 341- Industrial and Organizational Psychology
PSY 482 – Selective Topics in Industrial and Organizational Psychology

Ufuk University, Department of Psychology (Undergraduate)
PSY 103- Felsefeye Giriş

PUBLICATIONS AND CONFERENCE PRESENTATIONS.

Yalçın, A. & Bilgiç, R. (2011). *Mediating Roles of Job Satisfaction and Burnout in the Relationship Between Negative Events and Employee Turnover*. Oral presentation at the 12th European Congress of Psychology, Istanbul, Turkey.

Yalçın, A. & Bilgiç, R. (2011). *Big Five Personality Dimensions as Predictors of Emotional Labor*. Poster presented at the 12th European Congress of Psychology, Istanbul, Turkey.

Yalçın, A. & Bilgiç, R. (2011). *Moderating Role of Personality Dimensions in the Relationship Between Affective Events and Work Outcomes*. Poster presented at the Asian Congress of Psychology, Osaka, Japan

Yalçın, A. & Bilgiç, R. (2010, June) *Counterproductive Work Behavior: An Examination of Causal Reasoning Perspective*. Poster presented at the 2nd Biennial Institute of Work Psychology Conference on Work, Well-being & Performance, Sheffield, UK.

HONORS & REWARDS

Awarded with TUBITAK-BIDEB National Scholarship Program for Ph.D Students, 2010

Awarded with TUBITAK- BIDEB National Scholarship Program for MS. Students, 2007

Graduated from Philosophy Department (Major) with the highest C.GPA, ranking the 1st, High Honor Degree, 2006

Graduated from Psychology Department (Minor) with High Honor Degree, 2006

SKILLS & QUALIFICATIONS

Statistical Programs (SPSS, LISREL, EQS), Personnel Selection, Job (Re)Design, Job Analysis, Performance Appraisal

RESEARCH INTERESTS

Emotions at work, emotional labor, gender and leadership, personality, counterproductive work behaviors, Self-Determination Theory (SDT), Terror Management Theory (TMT), the self, philosophy, history and philosophy of science.

FOREIGN LANGUAGE SKILLS

English (Proficient)

Russian (Basic)

German (Basic)

F.TURKISH SUMMARY/ TÜRKÇE ÖZET

Giriş

İş-aile çatışması, birbirleri ile çelişen iş ve aile yükümlülüklerinden doğan bir rol çatışması (Greenhaus & Beutell, 1985) olarak tanımlanabilir. Bu tanıma göre, bir alandaki (örn., iş) yükümlülükler bireyin diğer alandaki (örn., aile) yükümlülüklerini yerine getirmesini engellemekte ve kişinin her iki role (iş rolü ve aile rolü) katılımını zorlaştırmaktadır. İş-aile çatışması kavramı, esas olarak, bireyin kaynaklarının (zaman, enerji vb.) sınırlı olduğu varsayımına dayanmaktadır. Buna göre bir rolden kaynaklanan yükümlülükler ve baskılar bireyin bu sınırlı kaynaklarını tüketerek, diğer role katılımını engeller ve en nihayetinde kişinin gerginlik, olumsuz duygulanım veya depresyon gibi negatif durumlar yaşamasına neden olur (Rothbard, 2001).

İş-aile çatışması ilk başta tek boyutlu bir kavram olarak öne sürülmüşse de, sonraki çalışmalar (örn., Gutek ve ark., 1991) iş-aile çatışmasının işten aileye çatışma (İAÇ) ve aileden işe çatışma (AİÇ) olmak üzere ilişkili, ancak birbirinden ayrı, iki boyuttan oluştuğunu göstermiştir. İAÇ iş yükümlülüklerinin aile yükümlülüklerine engel olarak, kişinin aile hayatındaki performansını düşürme durumunu yansıtırken, AİÇ aile yükümlülüklerinin iş yükümlülüklerine engel olarak, kişinin iş hayatındaki performansını düşürme durumunu yansıtmaktadır. Mevcut literatür İAÇ ve AİÇ'nin kendine özgü öncülleri ve sonuçları olduğuna işaret etmektedir (örn., Byron, 2005; Carlson ve ark., 2000; Ford ve ark., 2007; Frone ve ark., 1992; Frone ve ark., 1997; Kossek ve Ozeki, 1998; Michel ve ark., 2011).

Yapılan çok sayıda araştırmaya rağmen, ilgili yazının temel kısıtı iş-aile çatışmasının güdüsel yönlerinin ihmal edilmiş olmasıdır. Ancak, iş ve aile etkileşiminin altında yatan güdüsel süreçleri anlamak kişilerin en başta neden iş-aile çatışması yaşadıklarını anlamamıza yardımcı olabilir. Bu nedenle, iş-aile çatışmasının temelindeki güdüsel süreçleri incelemek bu çalışmanın en temel amacını oluşturmaktadır. Bunu yaparken, çalışma esas olarak Öz-Belirleme Kuramı'ndan (ÖBK; & Ryan, 1985, 2000) faydalanmaktadır.

ÖBK' ya göre kişisel gelişim ve iyi oluş hali için tatmin edilmesi gereken üç temel psikolojik ihtiyaç vardır. Bunlar, *yeterlilik, özerklik ve ilişkisellik*dir. *Yeterlilik*, bireyin çevresi ile olan etkileşiminde kendini etkin ve yetkin hissetmesini temsil etmektedir (Harter, 1983). *Özerklik*, bireyin kendini davranışlarının esas kaynağı olarak görmesi, başkalarının baskısı veya etkisi altında kalmadan, kendi özgür iradesi ve istekleri doğrultusunda eylemlerde bulunmasını temsil etmektedir (deCharms, 1968; Deci ve Ryan, 1985). *İlişkisellik* ise, kişinin insanlarla ve sosyal çevresi ile yakın ve güvenli ilişkiler kurabilmesi, ve bu sayede çevresinden kabul, saygı ve ilgi gördüğünü hissetmesi anlamına gelmektedir. (Baumeister ve Leary, 1995). ÖBK'ya göre bireyin optimal düzeyde işlev görebilmesi ve psikolojik refahı için bu üç ihtiyacın her zaman ve muhakkak karşılanması gerekmektedir.

ÖBK'nın temel önermelerinden biri de motivasyon türleri arasındaki ayrıma ilişkindir. ÖBK'ya göre, insan davranışının altında yatan altı çeşit motivasyon vardır. Bunlar, *motivasyonsuzluk, dıştan gelen (external) motivasyon, içe alınmış motivasyon, özdeşleşmiş motivasyon, bütünleşmiş motivasyon ve içsel motivasyondur*. *Motivasyonsuzluk*, bireyin herhangi bir davranışta bulunma konusundaki ilgisizliğini, isteksizliğini ve amaçsızlığını temsil etmektedir. *Dıştan gelen motivasyon*, kişinin bir eylemi dıştan gelen baskılar sonucunda bir ödüle ulaşmak veya bir cezadan kaçınmak için yapması durumunda gerçekleşir. *İçe alınmış motivasyonda* birey eylemi yine bir tür baskı nedeniyle yapmaktadır. Ancak, bu baskının kaynağı kişinin kendisidir. Buna göre, kişi eylemi suçluluk veya utanç duygusundan kaçınmak veya kendisiyle gurur duymak amacı ile gerçekleştirir. *Özdeşleşmiş motivasyon* bireyin eylemi değerli ve önemli bulduğu için yapmasını yasıtmaktadır. Bu anlamda, kişi eylemi ile özdeşir ve eylemini sahiplenir. *Bütünleşmiş motivasyon*, kişinin davranışının değerini kendi benliğiyle bütünleştirilmesi sonucunda ortaya çıkar. Bu durumda birey davranışının sonucunda edindiği değer, ihtiyaç ve hedefleri, benlik sistemindeki diğer değer, ihtiyaç ve hedefler ile bütünleştirir ve onları tam olarak özümser. Son olarak *içsel motivasyon*, bireyin bir eylemi sadece onu yapmaktan zevk ve keyif aldığı için gerçekleştirmesi durumunu yansıtır.

ÖBK' ya göre, yukarıda belirtilen bu altı motivasyon çeşidini içerdikleri özerklik düzeyine bağlı olarak bir öz-belirleme sürekliliğinde sıralamak mümkündür. Bu süreklilik düzleminde motivasyonsuzluk, dıştan gelen motivasyon, içe alınmış motivasyon daha az özerklik içermekte, birey tarafından daha az içselleştirilmektedir. Bu yüzden, bu üç tip motivasyon *kontrollü (öz-belirlenmemiş)* motivasyon formunu oluşturmaktadır. Buna karşın özdeşleşmiş motivasyon, bütünleşmiş motivasyon ve içsel motivasyon türleri, daha fazla özerklik içermekte ve birey tarafından daha çok içselleştirilmektedir. Bu yüzden, bu üç tip motivasyon *özerk (öz-belirlenmiş)* motivasyon formunu oluşturmaktadır.

Kurama göre, yukarıda bahsedilen üç temel psikolojik ihtiyacın (yeterlilik, özerklik, ve ilişkisellik) çevresel faktörler tarafından karşılanması daha özerk (öz-belirlenmiş) motivasyona sebep olmakta ve birey açısından olumlu sonuçlar doğurmaktadır. Diğer taraftan, çevresel faktörlerin bu ihtiyaçlara ket vurması daha kontrollü (öz-belirlenmemiş) motivasyona sebep olmakta ve birey açısından olumsuz sonuçlar doğurmaktadır.

Çalışmada, ÖBK'nın temel önermeleri esas alınarak iş-aile çatışmasının bireyin işine ve ailesine yönelik motivasyonu tarafından belirleneceği düşünülmüştür. İşe yönelik özerk motivasyona sahip bireyler işin gerekliliklerini yerine getirmekten daha çok keyif duydukları ve işe yönelik eylemleri daha fazla içselleştirdikleri için, işlerini bir çatışma kaynağı olarak görmeyecek ve daha az İAÇ rapor etmeye eğilimli olacaklardır. Benzer bir şekilde, aileye yönelik özerk motivasyona sahip bireyler, aileye hayatının gerekliliklerini daha istemli bir şekilde yerine getireceklerinden, bu gereklilikleri iş hayatlarına engel olan ve iş performanslarını düşüren bir çatışma kaynağı olarak algılamayacak ve daha az AİÇ rapor etmeye eğilimli olacaklardır. İlgili literatürde, Senecal ve ark. (2001) çalışması, bu önermeleri destekler niteliktedir. Araştırmacılar, işe yönelik özerk motivasyonun ve aileye yönelik özerk motivasyonun iş-aile çatışmasını aileye karşı yabancılaşma aracılığı ile negatif bir biçimde yordadığını göstermişlerdir. Ayrıca, bireylerin işe ve aileye ilişkin motivasyonel yönelimlerin, etkileşime girerek, yaşanacak olan iş-aile çatışmasının türünü belirleyeceği öngörülmektedir. Eğer

düşünüldüğü gibi özerk motivasyon daha düşük seviyede İAÇ/AİÇ' ye neden olmakta ve yaşanacak olan iş-aile çatışması türünü belirlemekteyse, o zaman hem iş hem de aile ortamında özerk motivasyona sebep olan faktörlerin incelenmesi önem taşımaktadır.

Bu çalışmada, İş Özellikleri Kuramı'nın (İÖK; Hackman ve Oldham, 1976, 1980) varsayımlarından yola çıkılarak işin beş temel motive edici özelliğinin (*beceri çeşitliliği, görev kimliği, görev anlamlılığı, özerklik ve geribildirim*) ÖBK'nda öne sürülen *üç temel psikolojik ihtiyacı (yeterlilik, özerklik ve ilişkisellik)* karşılayacağı, ve buna bağlı olarak bireyin işe yönelik özerk motivasyonunu artıracığı düşünülmüştür. Mevcut literatürde her ne kadar kısıtlı sayıda da olsa, iş özellikleri ile işe yönelik özerk motivasyon arasında pozitif ilişki bulan çalışmalar bulunmaktadır. (örn., De Coomen ve ark., 2013; Gagne ve ark., 1997; Millette ve Gagne, 2008).

İş özelliklerinin yanı sıra, iş ortamında algılanan sosyal desteğin de bireyin temel ihtiyaçlarını karşılayarak, işe yönelik motivasyonunu belirleyeceği çalışma kapsamında öne sürülmüştür. Buna uygun olarak, yapılan çalışmalar amirten ve iş arkadaşlarından gelen sosyal desteğinin çalışanların içsel ve özerk motivasyonlarını artırdığını göstermiştir (örn., Fernet ve ark., 2010; Fernet ve ark., 2012; Houkes ve ark., 2001; Nie ve ark., 2014).

Aile alanında ise, eş desteğinin ve aile hayatına ilişkin olaylara yönelik kontrol algısının aileye yönelik özerk motivasyonu belirleyeceği düşünülmüştür. Eşlerinden ilgi, sıcaklık ve şevkat gören kişilerin ilişkisellik ihtiyacının karşılanmış olması mümkündür. Aynı zamanda, eşinin beceri ve yeteneklerine güvenen, aileye ilişkin işlerde yardımcı olan ve zorluklar karşısında eşine cesaret veren kişiler, partnerlerinin yeterlilik ihtiyacını karşılayacaktır. Ayrıca, eşlerine yönelik baskı kurmadan, onların kararlarına ve eylemlerine saygı duyan kişiler eşlerinin özerklik ihtiyacını karşılayabilirler. Sonuç olarak partnerlerinden bu şekilde destek gören bireyler, temel psikolojik ihtiyaçları karşılandığı için ailelerine yönelik daha özerk bir motivasyon sergileyebilirler. ÖBK'ndan faydalarak yakın ilişkiler üzerinde yapılan çalışmalar (örn., Bouchard ve ark., 2007; Feeney, 2004; La Guardia ve ark.,

2000; Molden, 2009; Overall ve ark., 2010) yukarıda bahsi geçen argümanları destekler niteliktedir.

Bireylerin aile hayatına ilişkin olaylara yönelik kontrol algısının da aileye yönelik özerk motivasyonun bir öncülü olacağı düşünülmektedir. Algılanan kontrol kişilerin çevrelerini değiştirme ve çevrelerine etki etme becerilerine yönelik düşüncelerini yansıtmaktadır (Burger, 1989). Kontrol algısı yüksek olan kişiler, başlarına gelen olayların kendi davranışlarından ve çabalarından kaynaklı olduğunu düşünürken, kontrol algısı düşük olan kişiler bu olayları şans, kader gibi kontrollerinde olmayan nedenlere bağlamaktadırlar. Bu açıdan düşünüldüğünde , bireyin kontrol algısının yüksek olması, onun yeterlilik ihtiyacının karşılandığı anlamına gelmektedir. Bu bağlamda, aile hayatına yönelik olaylara karşı kontrol algısı yüksek olan kişilerin, ailelerine yönelik daha özerk bir motivasyon sergilemesi mümkündür. Bu iki kavram arasındaki ilişkiyi inceleyen çalışmalar eğitim alanında yapılmış olsa da, bahsi geçen önermeleri doğrulamaktadır (örn., Amoura, 2013; d'Ailly 2003; Patrick ve ark., 1993; Skinner ve ark., 1990).

Bu çalışma kapsamında, sadece iş-aile çatışmasının öncülleri değil, aynı zaman da olası sonuçları da incelenmektedir. İlgili yazında iş-aile çatışmasının iş doyumuna (örn., Kossek ve Ozeki, 1998; Netemayer ve ark., 1996; Öcal, 2008), aile doyumuna (örn., Aryee, ve ark., 1999; Amstad ve ark., 2011; Shockley ve Singla, 2011), ve duygusal tükenmişliğe (örn., Karatepe ve Tekinkuş 2006; Rubio ve ark., 2015; Rupert, ve ark., 2009) olan etkileri sıklıkla araştırılmış, ve anlamlı sonuçlar elde edilmiştir. Ancak, bu değişkenleri iş-aile çatışmasının hangi boyutunun (İAÇ, AİÇ) daha baskın bir şekilde yordayacağı konusunda araştırmacılar arasında uzlaşmazlık bulunmaktadır. Bazı araştırmacılar (örn., Frye ve Breaugh, 2004; Grandey ve ark., 2005; Voydanoff, 2001) bir alandan (örn., iş) kaynaklanan çatışmanın esas olarak o alana ilişkin (örn., iş) sonuçları belirleyeceğini söyleyerek *Eşleşme Yaklaşımı*' nı benimserken, diğer araştırmacılar (örn., Carlson ve Kacmar, 2000; Ford ve ark., 2007; Frone ve ark., 1992; Frone ve ark., 1997) bir alandan (örn.,

iş) kaynaklanan çatışmanın diğer alandaki performansı etkileyerek (örn., aile), karşı alandaki sonuçları belirleyeceği argümanını öne sürerek *Karşı Alan Yaklaşımı*'ni savunmuşlardır.

Geçmiş çalışmalar her iki yaklaşımı da destekleyen bulgular ortaya koysa da (bkz., Carlson ve Kacmar, 2000; Ford ve ark., 2007; Frone ve ark., 1992; Frone ve ark., 1997) Kossek ve Ozeki, Wayne ve ark., 2002), son çalışmalar Eşleşme Yaklaşımı'na yönelik daha fazla kanıt olduğunu göstermiştir (bkz., Amstad ve ark., 2011; Nohe, 2014; Shockley ve Singla, 2011). Bu yüzden bu çalışmada esas olarak Eşleşme Yaklaşımı temel alınmış ve İAÇ'nin iş doyumunu ve iş kaynaklı duygusal tükenme ile ilişkili, AİÇ'nin de aile doyumunu ve aile kaynaklı duygusal tükenme ile ilişkili olacağı varsayılmıştır. Ancak, yukarıda bahsedilen karşı ilişkileri bulan çalışmalar da göz önünde bulundurularak, İAÇ'nin aile doyumunu üzerinde, AİÇ'nin de iş doyumunu üzerinde zayıf ama anlamlı etkileri olacağı önerilmektedir.

Literatürdeki birçok çalışma, hem iş doyumunun hem de aile doyumunun bireyin yaşam doyumuna katkıda bulunduğunu göstermiştir (örn., Ahmad, 1996; Carlson ve Kacmar, 2000; Haar ve ark., 2014; Lapierre ve ark., 2008; Rice ve ark., 1992). Bu yüzden, mevcut araştırmada da iş doyumunu ve aile doyumunu arasında pozitif bir ilişki olacağı öngörülmüştür.

Bu çalışmada ayrıca işe ve aileye yönelik motivasyonun belirleyicileri (iş özellikleri, iş desteği, eş desteği, ailede algılanan kontrol) ile iş-aile çatışmasının yakınsal sonuçları (iş doyumunu, iş kaynaklı tükenmişlik, aile doyumunu, aile kaynaklı tükenmişlik) arasında doğrudan ilişkiler beklenmektedir. Nitekim, iş özelliklerinin iş doyumunu ile pozitif yönde, duygusal tükenmişlik ile negatif yönde ilişkili olduğunu gösteren pek çok çalışma mevcuttur (örn., Behson ve ark., 2000; Demerouti ve ark., 2010; Fried ve Ferris, 1987; Liden ve ark., 2000; Schaufeli ve Bakker, 2004; Xanthopoulou, ve ark., 2007).

Aynı şekilde, iş desteğinin iş doyumunu ile pozitif yönde, duygusal tükenmişlik ile negatif yönde ilişkili olduğunu ortaya koyan pek çok araştırma mevcuttur (örn., Fernet ve ark., 2010; Gözükara ve Çolakoğlu, 2015; Kale, 2015; Baeriswyl ve ark.,

2016; Bakker ve ark., 2003, Halbesleben, 2006; Tayfur ve Arslan, 2013; Yürür ve Sarıkaya, 2012). Bu bulgular ışığında iş desteğinin iş doyumunu ve iş tükenmişliğini doğrudan etkileyeceği düşünülmektedir.

Benzer bir biçimde, aile alanında eş desteğinin ve algılanan kontrolün aile doyumunu ve aile kaynaklı duygusal tükenmişlik üzerinde doğrudan etkileri olması beklenmektedir. Yakın ilişkiler üzerinde yapılan geçmişteki bir çok araştırma da algılanan eş desteği ile evlilik/aile doyumunu arasında pozitif ilişki bulmuştur (örn., Acitelli ve Antonucci, 1994; Cutrona ve Suhr, 1994; Dehle ve ark., 2001; Overall ve ark., 2010; Xu ve Burleson, 2004). Öte yandan, eş desteğinin tükenmişlik üzerindeki etkileri çoğunlukla iş-aile etkileşimi çerçevesinde araştırılmıştır. Söz konusu çalışmalar, eşten alınan desteğin ters bir biçimde duygusal tükenmişliği yordadığını göstermiştir (örn., Kulik ve Rayyan, 2003; Halbesleben ve ark., 2010; Halbesleben ve ark., 2011; Rupert ve ark., , 2009). Bu bulgulara dayanarak, eş desteğinin aile doyumuna ve tükenmişliğe doğrudan etki edeceği düşünülmektedir.

Algılanan kontrol düzeyinin ilişkiler üzerindeki etkisini araştıran sınırlı sayıda çalışma olmasına rağmen, yüksek kontrol algısının aile doyumunu artıracak varsayımını destekleyen çalışmalar mevcuttur (örn., Camp ve Ganong, 1997; Madden ve Janoff-Bulman, 1981; Miller ve ark., 1986; Myers ve Booth, 1999). Kontrol algısı ve duygusal tükenmişlik arasındaki ilişkiyi inceleyen araştırmalar ise daha çok *İş Gereklilikleri- Kontrol Modeli'* ne (İG-KM; Karasek, 1979) dayanmakta olup, genellikle iş ortamında yapılmıştır. İG-KM'ye göre, bireyin işi üzerindeki kontrol algısı, iş yükünün birey üzerindeki olumsuz etkilerine karşı kişiyi korumaktadır. İG-KM'nin bu varsayımı, işteki kontrol algısının yorgunluk, tükenmişlik ve gerginlik hislerini azaltarak bireyin sağlığını doğrudan etkilediğini gösteren çalışmalar tarafından desteklenmiştir (örn., de Rjick ve ark., 1998; Häusser ve ark., 2010; Park ve ark., 2014). Bu bulgular göz önünde bulundurulduğunda, algılanan kontrol ile duygusal tükenmişlik arasındaki ilişkinin aile ortamında da geçerli olacağı düşünülmektedir.

Daha önceden belirtildiği gibi, geçmişteki çalışmalar iş-aile çatışması boyutları ve doyumsal değişkenler arasında ki ilişkiye dair tutarsız sonuçlar

vermiştir. Kossek ve Ozeki' ye göre (1998) bu çelişkili bulguların nedeni söz konusu ilişkilerde düzenleyici olarak rol alan başka değişkenlerin olma ihtimalidir. Bu ilişkilerde düzenleyici rol üstleneceği düşünülen olası bir değişken iş/aile rolü ile özdeşimdir.

Kimlik Kuramı'na göre (Stryker, 1980; Stryker ve Serpe) kişinin 'Ben kimim?' sorusuna verdiği cevapların her biri bireyin kimliğini yansıtır. Birey bu kimliklere ve içerdiği rollere yüklediği anlam ve değerler sayesinde benlik sisteminde bir roller hiyerarşisi yaratır. Toplum tarafından kabul gören, ödüllendirilen, ve başarı ile gerçekleştirilen roller kişinin baskın rollerini temsil eder ve bu hiyerarşinin daha yüksek basamaklarına yerleşir. Kişi bu baskın rollerle özdeşir ve bu rollerin gerekliliklerini yerine getirmek için uğraş verir. Buna karşın, maliyetli, sosyal olarak arzulanmayan ve başarılı olunmayan roller, baskın roller değildir ve hiyerarşinin alt basamaklarında konumlanır (Burke ve Reitzes, 1981; Stryker, 1980). Birey için bu roller ile özdeşim kurmaz ve gerekliliklerini yerine getirmek için fazla çaba harcamaz.

Kimlik Kuramı'nın bu varsayımları iş-aile çatışmasına uyarlanabilir. Örneğin, iş rolü ile yüksek seviyede özdeşleşmiş kişilerin işyerindeki bir olumsuzluğu aile hayatlarına taşıma ihtimali yüksektir. Bu kişiler için iş rolü baskın bir rol olduğundan, iş kaynaklı bu olumsuzluklar bireyin aile hayatına daha fazla yansiyabilir ve aile alanına ilişkin daha olumsuz sonuçlar doğurabilir. Bu bağlamda düşünülecek olduğunda, İAÇ'nin aile doyumu üzerindeki negatif etkilerinin iş ile yüksek seviyede özdeşleşmiş kişiler için, iş ile düşük seviyede özdeşleşmiş kişilere kıyasla, daha fazla olacağı söylenebilir. Benzer bir biçimde, aile rolü ile yüksek seviyede özdeşleşmiş kişiler için ailede yaşanacak herhangi bir problemin iş alanına sıçraması ve iş doyumunu düşürmesi daha olasıdır. Bu yüzden İAÇ'nin iş doyumunu üzerindeki negatif etkilerinin aile rolü ile yüksek seviyede özdeşleşmiş kişiler için, aile rolü ile düşük seviyede özdeşleşmiş kişilere kıyasla, daha fazla olacağı söylenebilir. Literatürde, rol özdeşiminin iş-aile çatışması sonuçları üzerindeki etkisini inceleyen sınırlı sayıda çalışma birbiriyle tutarsız sonuçlar verse de yukarıdaki varsayımlar bazı çalışmalar tarafından desteklenmiştir (Carlson ve Kacmar, 2000; Simon, 1992; Noor, 2004).

Yukarıdaki varsayımlar ve bulgular doğrultusunda araştırmanın temel hipotezleri oluşturmuştur. Ayrıca, bu hipotezleri bir araya getiren bütünleştirici bir model öne sürülmüştür. Çalışmanın hipotezleri aşağıda belirtilmiştir. Ayrıca, öne sürülen model, Figür 1a ve Figür 1b 'de gösterilmiştir.

H1a: İşe yönelik özerk motivasyon ile İAÇ arasında negatif yönde bir ilişki olacaktır.

H1b: Aileye yönelik özerk motivasyon ile AİÇ arasında negatif yönde bir ilişki olacaktır.

H2: İşe ve aileye yönelik özerk ve kontrollü motivasyonun iş-aile çatışması boyutları üzerinde etkileşimli bir etkisi olacaktır. Özel olarak,

H2a: Ailesine karşı özerk, ancak işine karşı kontrollü motivasyon sergileyen bireyler, AİÇ'den ziyade, İAÇ yaşamaya eğilimli olacaktır.

H2b: İşine karşı özerk, ancak ailesine karşı kontrollü motivasyon sergileyen bireyler, İAÇ'den ziyade, AİÇ yaşamaya eğilimli olacaktır.

H2c: Ailesine ve işine karşı kontrollü motivasyon sergileyen bireyler hem AİÇ'yi hem de İAÇ'yi en yüksek seviyede yaşayacaklardır.

H2d: Ailesine ve işine karşı özerk motivasyon sergileyen bireyler hem AİÇ'yi hem de İAÇ'yi en düşük seviyede yaşayacaklardır.

H3a: MEP (işin beceri çeşitliliği, görev kimliği, görev anlamlılığı, özerklik ve geribildirim özellikleri ile belirlenen motive etme potansiyeli) ile işe yönelik özerk motivasyon arasında pozitif yönde bir ilişki olacaktır.

H3b: Algılanan iş desteği ile işe yönelik özerk motivasyon arasında pozitif yönde ilişki olacaktır.

H4a: Algılanan eş desteği ve aileye yönelik özerk motivasyon arasında pozitif yönde ilişki olacaktır.

H4b: Ailede algılanan kontrol düzeyi ve aileye yönelik özerk motivasyon arasında pozitif yönde ilişki olacaktır.

H5: İAÇ, **a)** iş doyumunu ile negatif yönde, **b)** iş kaynaklı duygusal tükenmişlik ile pozitif yönde ilişkili olacaktır.

H6: AİÇ, **a)** aile doyumunu ile negatif yönde, **b)** aile kaynaklı duygusal tükenmişlik ile pozitif yönde ilişki olacaktır.

H7: İAÇ ile aile doyumunu arasında negatif yönde, zayıf bir ilişki olacaktır.

H8: AİÇ ile iş doyumunu arasında negatif yönde, zayıf bir ilişki olacaktır

H9: Yaşam doyumunu ile **a)** iş doyumunu **b)** aile doyumunu arasında pozitif bir ilişki olacaktır.

H10: İş özellikleri **a)** iş doyumunu ile doğrudan ve pozitif yönde **b)** iş kaynaklı duygusal tükenmişlik ile doğrudan ve negatif yönde ilişkili olacaktır.

H11: İş desteği **a)** iş doyumunu ile doğrudan ve pozitif yönde **b)** iş kaynaklı duygusal tükenmişlik ile doğrudan ve negatif yönde ilişkili olacaktır.

H12: Eş desteği **a)** aile doyumunu ile doğrudan ve pozitif yönde **b)** aile kaynaklı duygusal tükenmişlik ile doğrudan ve negatif yönde ilişkili olacaktır.

H13: Algılanan kontrol düzeyi **a)** aile doyumunu ile doğrudan ve pozitif yönde **b)** aile kaynaklı duygusal tükenmişlik ile doğrudan ve negatif yönde ilişkili olacaktır.

H14: İAÇ ile aile doyumunu arasındaki ilişki iş rolü ile özdeşim tarafından düzenlenecektir. Şöyle ki, İAÇ ve aile doyumunu arasındaki negatif ilişki, iş rolü ile yüksek seviyede özdeşleşmiş kişilerde, iş rolü ile düşük seviyede özdeşleşmiş kişilere kıyasla, daha güçlü olacaktır.

H15: AİÇ ile iş doyumunu arasındaki ilişki aile rolü ile özdeşim tarafından düzenlenecektir. Şöyle ki, AİÇ ve iş doyumunu arasındaki negatif ilişki, aile rolü ile yüksek seviyede özdeşleşmiş kişilerde, aile rolü ile düşük seviyede özdeşleşmiş kişilere kıyasla, daha güçlü olacaktır.



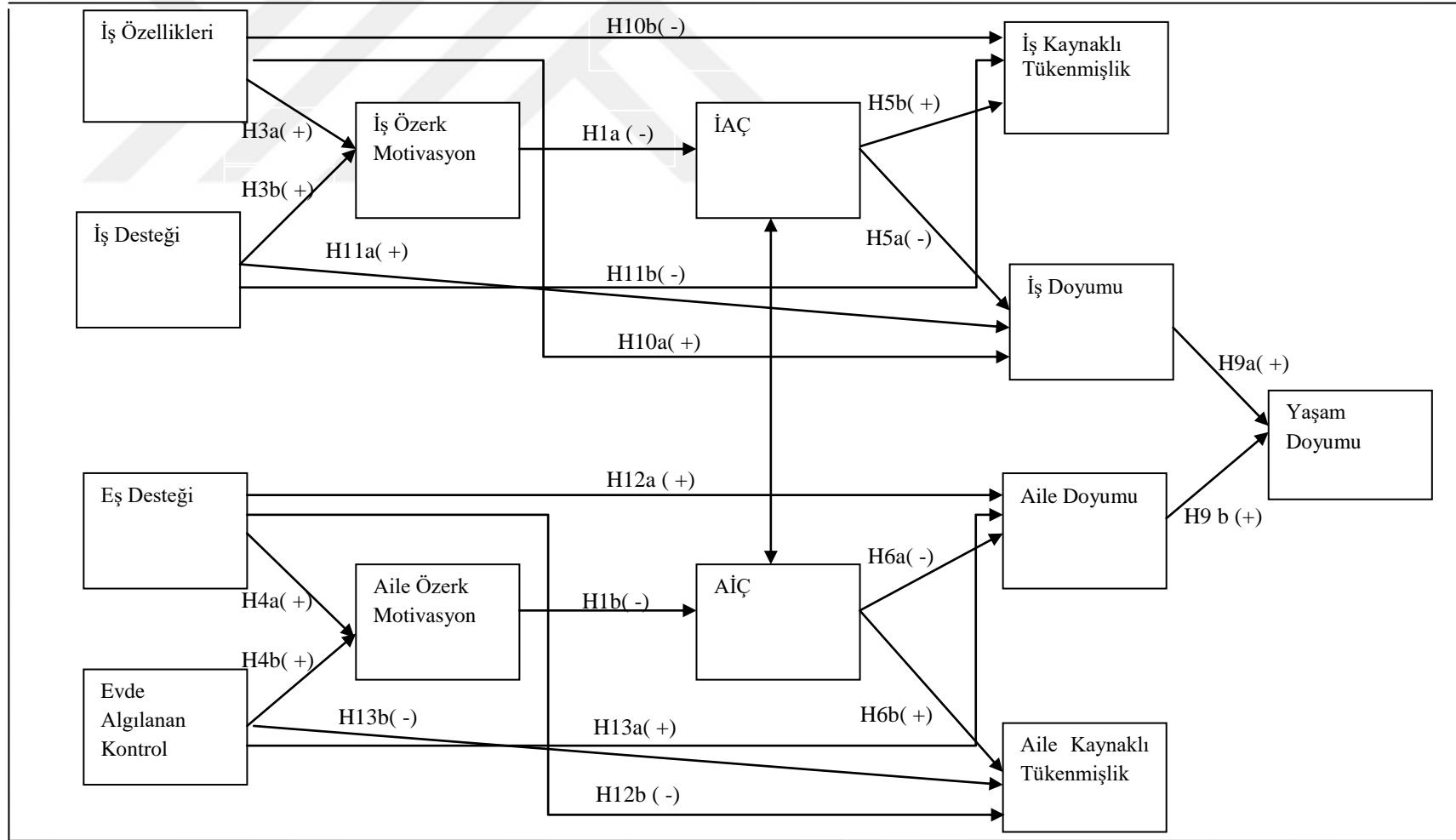

Figür 1a Önerilen İş-Aile Çatışması Modeli

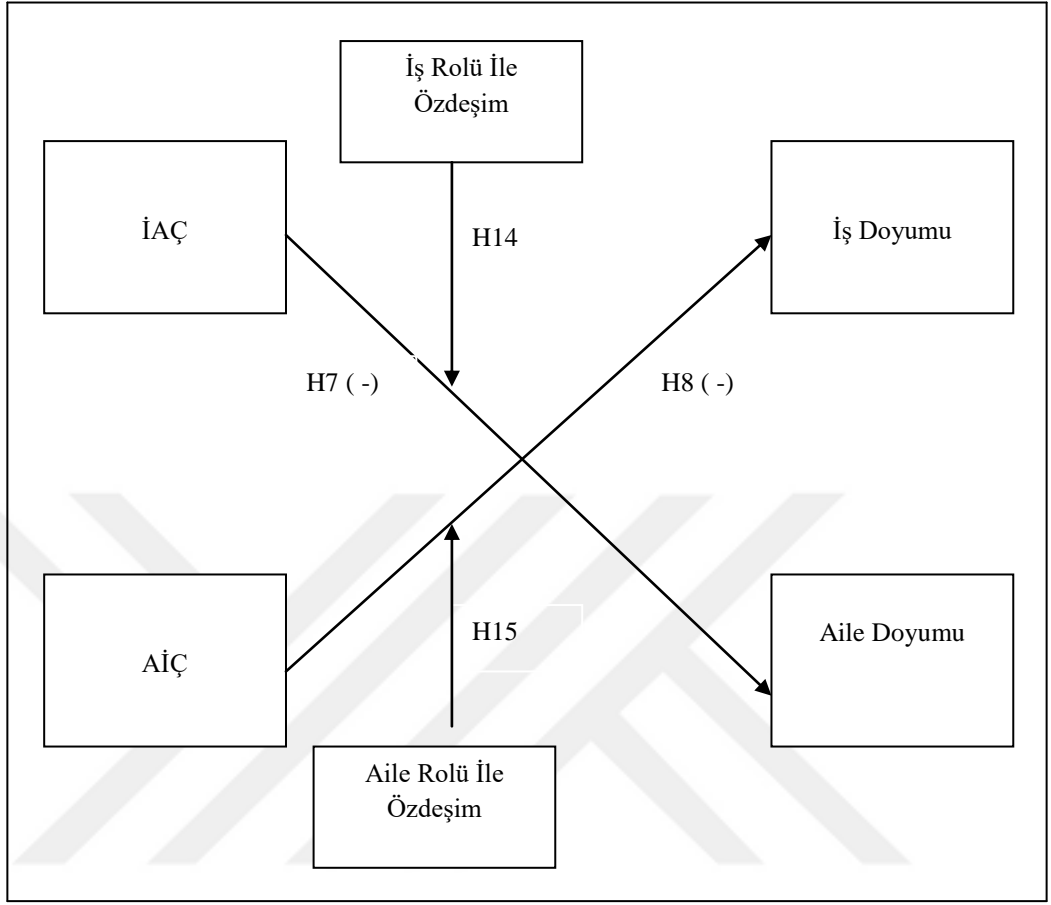

Figür 1b Önerilen İş-Aile Catışması Modeli

Ön Çalışma

Ana çalışmada kullanılacak olan ölçeklerin psikometrik özelliklerini ve faktör yapılarını değerlendirmek üzere bir ön çalışma gerçekleştirilmiştir.

Yöntem

Katılımcılar ve İşlem

Ön çalışmadak veriler kartopu tekniği kullanılarak toplanmıştır. Özel bir üniversitenin Psikoloji Bölümü öğrencilerine ölçüm araçlarını içeren anketler gönüllü katılım ve bilgilendirme formları ile birlikte kapalı zarflar içerisinde verilmiştir. Öğrencilerden bir puan bonus karşılığında anketleri, çift kazançlı, 18 yaşından küçük en az bir çocuğu bulanan evli bireylere iletmeleri istenmiştir. Ön çalışmanın analizleri 407 katılımcı üzerinde gerçekleştirilmiştir.

Ön çalışmaya katılan 407 kişiden 260'ı (% 63.9) kadın, 147'si ise (%36.1) erkektir. Katılımcıların yaşları 26-59 arasında değişmektedir. Katılımcıların çoğunluğu (%65.5) üniversite mezunu olmakla birlikte, %20.6'sı lise mezunu, %9.1'i yüksek lisans/doktora mezunu, %4.4'ü ise ilköğretim mezunudur. Katılımcıların iş tecrübesi ortalama 15 yıldır. Katılımcıların 239'u (%58.7) çalışma saatlerinin hiçbir şekilde esnek olmadığını belirtirken, 125'i (%30.7) çalışma saatlerinin esnek olduğunu rapor etmiştir. Öte yandan, 39 (%9.6) katılımcı kısmen esnek çalışma saatlerine sahip olduğunu belirtmiştir. Çalışmaya katılan 4 (%1) kişi ise çalışma saatleri hakkında herhangi bir bilgi vermemiştir.

İki yüz altmış altı (%55.5) katılımcının iki, 155 (%38.1) katılımcının bir çocuğu vardır. Bunun yanı sıra 23 (%5.7) katılımcı üç, 4 (%0.7) katılımcı dört çocuk sahibidir. Katılımcıların çocuklarının yaşları 0 ile 17 arasında değişmektedir.

İlgili bilgiyi veren katılımcılardan 247 (%60.7) tanesi ev işleri için dışarıdan, 184 tanesi ise çocuk bakımı için dışarıdan yardım aldığını belirtmiştir.

Ölçüm Araçları

İş-Aile Çatışması. Algılanan iş-aile çatışması Netemeyer ve arkadaşları (1996) tarafından geliştirilen, 10 maddelik İşten-Aileye ve Aileden-İşe Çatışma Ölçeği ile ölçülmüştür.

İşe Yönelik Motivasyon. Katılımcıların işe yönelik motivasyonlarını ölçmek için Tremblay ve arkadaşları (2009) tarafından İngilizce'ye adapte edilen İş için Dışsal ve İçsel Motivasyon Ölçeği (İDİMÖ) kullanılmıştır. Ölçek, 18 maddeden oluşmakta ve ÖBK (Deci & Ryan, 1985) tarafından öne sürülen bütün motivasyon çeşitlerini kapsamaktadır. Ölçek maddeleri Türkçe'ye bu çalışma kapsamında tercüme-geri tercüme yöntemi kullanılarak çevrilmiştir.

İş Özellikleri. Bireylerin işlerinin doğasına yönelik algıları Hackman ve Oldham'ın (1980) İş Tanı Ölçeği'nin (İTÖ) 15 maddelik Türkçe formu kullanılarak ölçülmüştür.

İş Desteği. İş yerinde algılanan amir ve iş arkadaşı desteğini ölçmek için İş Gereklilikleri ve Kaynakları Ölçeği'nden (Xanthopoulou ve ark., 2007) altı madde kullanılmıştır.

İş Yerinde Duygusal Tükenmişlik. İşten kaynaklı duygusal tükenmişlik Maslach Tükenmişlik Envanteri'nin (MTE; Maslach ve Johnson, 1986) Türkçe Formu'nun (Ergin, 1992) duygusal tükenmişlik boyutunu yansıtan 5 madde ile ölçülmüştür.

İş Doyumu. Katılımcıların iş doyumu İş Tanı Ölçeği'nin (İTÖ; Hackman & Oldham, 1975) Genel İş Doyumu altölçeği'nden alınan üç madde ve Kunin'in (1955) tek maddelik Yüzler Ölçeği kullanılarak ölçülmüştür.

Eş Desteği. Eşten alınan destek seviyesi Eş Destek Ölçeği'nin (Yıldırım, 2004) Duygusal Destek alt boyutunu yansıtan 8 madde ile ölçülmüştür.

Evde Algılanan Kontrol. Katılımcıların aile yaşantılarındaki kontrol hislerini değerlendirmek için Yabancılaşma Ölçeği'nin (Maddi ve ark., 1979) 8 maddelik

Yetkesizlik alt ölçeği kullanılmıştır. Ölçek maddeleri, ev ve aile yaşantısına Demokan (2009) tarafından adapte edilmiştir. Algılanan kontrol seviyesi ölçek maddelerinden alınan puanların ters çevrilmesi ile hesaplanmıştır.

Aileye Yönelik Motivasyon. Aileye yönelik motivasyon ölçeği ilgili literatürde ÖBK'na dayanarak oluşturulmuş, bireylerin farklı alanlardaki motivasyonlarını ölçmeye yönelik ölçüm araçlarının araştırmacı tarafından incelenmesi ve maddelerinin aile ortamına uyarlanması ile bu çalışma kapsamında geliştirilmiştir. Senecal ve Vallerand'ın (1999) çalışmasına dayanarak çeşitli aile aktivitelerini kapsayan 6 kategori (ev işlerine yönelik aktiviteler, çocukların eğitimine yönelik aktiviteler, çocukların fiziksel ve ruhsal gelişimine yönelik aktiviteler, çocuklar ile geçirilen boş zaman aktiviteleri, eşin fiziksel ve psikolojik sağlığına yönelik aktiviteler, eş ile geçirilen boş zaman aktiviteleri) oluşturulmuştur. Her bir kategori için ÖBK tarafından öne sürülen 6 motivasyon tipini (motivasyonsuzluk, içe alınmış motivasyon, dıştan gelen motivasyon, özdeşleşmiş motivasyon, bütünleşmiş motivasyon ve içsel motivasyon) yansıtan maddeler hazırlanmıştır. Ölçek, her aktivite kategorisinde bu altı motivasyon türünü ölçen bir madde bulundurmakta olup, toplamda 36 madde içermektedir.

Aile Doyumu. Aile doyumunu Yaşam Doyum Ölçeği'nden (YDÖ; Deiner ve ark., 1985) alınan ve Üzümcüoğlu (2013) tarafından aile yaşantısına uyarlanan 5 madde ile ölçülmüştür.

Ailede Duygusal Tükenmişlik. Aile yaşantısından kaynaklı duygusal tükenmişlik Maslach Tükenmişlik Envanteri'nin (MTE; Maslach ve Johnson, 1986) duygusal tükenmişlik alt boyutunu yansıtan 5 maddenin araştırmacı tarafından aile yaşantısına uyarlanması ile ölçülmüştür.

Yaşam Doyumu. Katılımcıların yaşam doyum seviyeleri Yaşam Doyum Ölçeği'nden (YDÖ; Deiner ve ark., 1985) alınan 5 madde ile ölçülmüştür.

Demografik Bilgiler ve Kontrol Değişkenleri. Katılımcılardan cinsiyetlerini, yaşlarını, eğitim seviyelerini, iş tecrübelerini, ne kadar süredir evli olduklarını, kaç çocuğa sahip olduklarını, ve çocuklarının yaşlarını belirtmeleri istenmiştir. Ayrıca, katılımcılardan esnek çalışma saatlerine sahip olup olmadıkları, çocuklarının bakımı ve iş işleri içindışıarıdan düzenli destek alıp almadıklarına dair bilgi istenmiştir.

Analizler ve Bulgular

Uygulanan ölçeklerin iç güvenilirlik katsayılarını hesaplamak ve faktör yapılarını incelemek için SPSS 16.0 programı kullanılarak bir dizi Güvenirlik Analizi ve Açımlayıcı Faktör Analizi (AFA) gerçekleştirilmiştir. Güvenirlik Analizi bulguları çalışmada kullanılan ölçeklerin yeterli iç tutarlılığa (.58 ve .94 arasında) sahip olduğunu göstermiştir. Ayrıca, Açımlayıcı Faktör Analizleri İşe Yönelik Motivasyon (İDİMÖ) ve Aileye Yönelik Motivasyon Ölçekleri dışında beklenen sonuçları vermiştir.

Beklenenin ve SDT çalışmalarının (e.g., Blais ve ark., 1993; Senecal ve Vallerand, 1999; Tremblay ve ark., 2009) aksine, AFA sonuçları İşe ve Aileye Yönelik Motivasyon Ölçekleri'nin sadece 3 boyuttan oluştuğunu göstermiştir. Her iki ölçekte de motivasyonsuzluk ve dıştan gelen (external) motivasyon boyutların ayrıştığı gözlemlense de, içsel motivasyon, bütünleşmiş motivasyon ve özdeşleşmiş motivasyon boyutlarının birleştiği saptanmıştır. Ayrıca, içe alınmış motivasyon maddelerinin çalışmadığı gözlemlenmiş ve analizlerden çıkarılmıştır. Faktör analizleri sonucunda elde edilen bu üç boyut içsel motivasyon, dıştan gelen gelen (external) motivasyon ve motivasyonsuzluk türlerini yansıtmaktadır. Bu üç boyut İşe Yönelik Motivasyon Ölçeği'nde %56, Aileye Yönelik Motivasyon Ölçeği'nde %42.62 varyans açıklamıştır.

Ölçeklerin iç tutarlılığını değerlendirmek amacı ile Güvenirlik Analizleri yapılmış ve ölçeklerin istenilen güvenilirlik değerlerine sahip olduğu bulunmuştur. Sekiz maddelik içsel motivasyon alt boyutunun iç tutarlık katsayısı .77, dört maddelik dıştan gelen motivasyon alt boyutunun ise iç tutarlık katsayısı .70, üçmaddelik motivasyonsuzluk alt boyutunun iç tutarlık .58 olarak bulunmuştur. On

yedi maddelik Aileye Yönelik Motivasyon Ölçeği'nin içsel (5 madde), dıştan gelen (7 madde) ve motivasyonsuzluk (5 madde) altboyutları için ise güvenilirlik katsayıları, sırasıyla, .76, .83 ve .79 olarak bulunmuştur.

Ana Çalışma

Ana çalışma Açıklayıcı Faktör Analizleri'nde ortaya çıkan faktör yapılarının başka bir örneklemede desteklenip desteklenmediğini anlamak ve ilgilenilen değişkenler arasındaki öngörülen ilişkileri test etmek için gerçekleştirilmiştir.

Yöntem

Katılımcılar ve İşlem

Ana çalışmada veriler ön çalışmada olduğu gibi kartopu tekniği kullanılarak toplanmıştır. Psikoloji Bölümü öğrencilerinden ölçüm araçlarını içeren anketleri bir puan bonus karşılığında çift kazançlı, 18 yaşından küçük en az bir çocuğu bulanan evli bireylere iletmeleri istenmiştir. Ana çalışmanın analizleri 405 katılımcı üzerinde gerçekleştirilmiştir.

Dört yüz beş kişiden 232'si (% 57.3) kadın, 173'ü ise (%42.7) erkektir. Katılımcıların yaşları 22-68 arasında değişmektedir. Katılımcıların çoğunluğu (%57) üniversite mezunu olmakla birlikte, %13.3'ü lise, %13.3 'ü yüksek lisans/doktora, %13.1' i önlisans, %3.42'si ilköğretim mezunudur. Katılımcıların iş tecrübesi yaklaşık 14 yıldır. Yüz seksen dört (%45.4) katılımcı çalışma saatlerinin esnek olmadığını, 96 (%23.7) katılımcı çalışma saatlerinin esnek olduğunu rapor etmiştir. Öte yandan, 124 (%30.6) katılımcı kısmen esnek çalışma saatlerine sahip olduğunu belirtmiştir. Çalışmaya katılan bir (%0.3) kişi ise çalışma saatleri hakkında bilgi vermemiştir.

Yüz doksan dokuz (%49.1) katılımcının iki, 167 (%41.2) katılımcının bir çocuğu vardır. Otuz dört (%8.4) katılımcı üç, 5 (% 1.2) katılımcı dört çocuk sahibidir. Katılımcıların çocuklarının yaşları 0 ile 17 arasında değişmektedir.

Katılımcıların 216 (%53.3) tanesi ev işleri için dışarıdan, 183 (%45.2) tanesi ise çocuk bakımı için dışarıdan yardım aldığını belirtmiştir.

Ölçüm Araçları

Ön çalışma bulguları ölçeklerin istenilen psikometrik özelliklere sahip olduğunu gösterdiğinden, ana çalışmada da aynı ölçüm araçları kullanılmıştır. Ayrıca, iş ve aile roller ile özdeşimin iş-aile çatışması boyutlarının diğer alandaki etkileri üzerindeki düzenleyici rolünü incelemek için, bu değişkenleri ölçen ölçüm araçları da ankete dahil edilmiştir.

İş Rolü ile Özdeşim. Katılımcıların iş rolleri ile özdeşim seviyelerini belirlemek için 6 maddelik İş Rolü İşe İlgili Ölçeği (Kanungo, 1982) kullanılmıştır.

Aile Rolü ile Özdeşim. Katılımcıların aile rolleri ile özdeşim seviyelerini belirlemek için İş Rolü İşe İlgili Ölçeği'nin (Kanungo, 1982) Bıçaksız (2009) tarafından aile rolüne revize edilmiş 6 maddelik formu kullanılmıştır.

Analizler

Ön çalışmada gerçekleştirilen ölçeklere ait AFA bulgularını desteklemek için EQS 6.1 (Benler ve Wu, 2005) programı kullanılarak Doğrulayıcı Faktör Analizleri (DFA) yapılmıştır. Çalışmada önerilen hipotezlerin ve modelde öne sürülen ilişkilerin testleri ise yine EQS 6.1 programı aracılığıyla yapılan yol analizleri (path analyses) ile gerçekleştirilmiştir. Ayrıca, değişkenler arası korelasyonların hesaplanması, iş ve aileye yönelik motivasyonların iş-aile çatışması boyutları üzerindeki etkileşimli etkilerinin incelenmesi ve iş/aile rolleri ile özdeşimin düzenleyici rollerinin değerlendirilmesi SPSS 16.0 kullanılarak yapılan analizlerle gerçekleştirilmiştir.

Bulgular

Doğrulayıcı Faktör Analizleri'ne İlişkin Bulgular

Ön çalışmada gerçekleştirilen AFA bulguları, ana çalışmada yapılan Doğrulayıcı Faktör Analizleri tarafından desteklenmiş, ölçeklerin faktör yapıları bu örneklem üzerinde de doğrulanmıştır. DFA bulgularına ilişkin sonuçlar EK D1-D14'te verilmiştir.

Değişkenler Arası Korelasyonlara İlişkin Bulgular

Korelasyon analizleri değişkenler arasında beklenen ilişkileri göstererek çalışmanın hipotezlerine ön destek sağlamıştır. Cinsiyetin, çalışmadaki birçok değişken ile ilişkili olduğu görülmüş, bunun üzerine bağımsız örneklem t-testleri yapılmıştır. Bulgular, kadın katılımcıların erkeklere kıyasla daha fazla İAÇ yaşadıklarını [$t(403) = 2.09, O. F. = .25, p < .05$] ve daha yüksek aileye yönelik özerk motivasyona sahip olduklarını [$t(403) = 2.29, O. F. = .72, p < .05$] göstermiştir. Öte yandan, erkek katılımcılar işlerini daha motive edici bulmuşlar, [$t(403) = -3.22, O. F. = -9.20, p < .005$], iş rolleri ile daha fazla özdeşleşmişler [$t(403) = -2.37, O. F. = -.20, p < .05$], ve işlerinden daha fazla doyum aldıklarını [$t(403) = -2.16, O. F. = -.29, p < .05$] belirtmişlerdir. Ayrıca erkek katılımcıların hem iş [$t(403) = 2.39, O. F. = .20, p < .05$] hem de aile [$t(403) = 4.82, O. F. = .39, p < .001$] kaynaklı duygusal tükenmişlik skorlarının kadın katılımcılara kıyasla daha düşük olduğu gözlemlenmiştir.

Literatür ile uyumlu olarak İAÇ ve AİÇ arasında orta derecede pozitif bir korelasyon ($r = .35, p < .01$) bulunmuştur. Katılımcıların İAÇ ile AİÇ skorları eşlenik örnekleme t-testi yapılarak karşılaştırılmıştır. Sonuçlar katılımcıların İAÇ skorlarının AİÇ skorlarından yüksek olduğunu [$t(404) = 10.69, p < .001, O_{IAÇ}(405) = 2.87, O_{AİÇ}(405) = 2.22$] göstermiştir. Bu bulgular iş-aile çatışmasının asimetrik geçirgenliğini, yani, İAÇ'nin AİÇ'den daha fazla yaşandığını desteklemiştir.

Hipotezlere İlişkin Bulgular

Model Testine İlişkin Bulgular. Şekil 1a ve 1b’de gösterilen modellere ilişkin yol analizleri EQS 6.1. (Bentler & Wu, 2005) kullanılarak yapılmıştır. İlk olarak önerilen model ile veri arasındaki uyumun kabul edilen düzeyde olmadığı [$\chi^2(47, 405) = 334.36, p < .001, CFI = .86, NFI = .84, RMSEA = .12$] görülmüştür. Bunun üzerine L-M test sonuçları incelenerek modelde gerekli düzeltmeler yapılmış, böylelikle model ve veri uyumunda iyileşme [$\chi^2(48, 405) = 200.27, (\chi^2 / d. f. oranı = 4.17), CFI = .92, GFI = .93, NFI = .90, SRMR = .09, RMSEA = .09, 90\% C.I. = .08, .10$] sağlanmıştır.

Hipotez 1a ve 1b’de beklendiği üzere işe yönelik özerk motivasyona sahip bireyler daha az İAÇ ($\beta = -.24$), aileye yönelik özerk motivasyona sahip bireyler de yine daha az AİÇ ($\beta = -.12$) yaşama eğilimindedir. Ayrıca, her ne kadar öngörülme de, L-M test modifikasyonlarına bağlı olarak ailede algılanan kontrol düzeyinin AİÇ’yi direkt olarak etkilediği ($\beta = -.31$) bulunmuştur. *Hipotez 3a ve 3b’de* öngörüldüğü gibi, işin motive etme potansiyeli (MEP) ve iş desteği işe yönelik özerk motivasyonu olumlu bir şekilde (sırasıyla, $\beta = .37, \beta = .23$) yordamıştır. Benzer bir şekilde, *Hipotez 4a ve 4b’nin* önermelerine uygun olarak, eş desteğinin ve ailede algılanan kontrol düzeyinin aileye yönelik özerk motivasyonu pozitif biçimde (sırasıyla, $\beta = .22, \beta = .34$) yordadığı görülmüştür. Ancak, beklentilerin aksine İAÇ ile iş doyumunu arasında anlamlı bir ilişki bulunamamıştır ($\beta = -.06, p > .05$). Bu yüzden, sıklıkla İAÇ yaşayan bireylerin daha düşük iş doyumuna sahip olacağını öngören *Hipotez 5a* doğrulanamamıştır. Diğer taraftan İAÇ’nin iş yerindeki duygusal tükenmişliği pozitif olarak yordadığı ($\beta = .45$) bulunmuştur. Bu anlamda, *Hipotez 5b’de* belirtilen İAÇ yaşayan bireylerin daha fazla iş kaynaklı duygusal tükenmişlik yaşayacağı yargısı yapılan analizler tarafından desteklenmiştir. Araştırma beklentilerine aykırı olarak, AİÇ ve aile doyumunu arasında da anlamlı bir ilişki ($\beta = -.01, p > .05$) bulunamamıştır. Yani, sıklıkla AİÇ yaşayan bireylerin daha düşük aile doyumuna sahip olacağını belirten *Hipotez 6a* desteklenmemiştir. Aynı şekilde AİÇ ve aile kaynaklı duygusal tükenmişlik arasında ilişki olmadığı ($\beta = .06, p > .05$)

saptanmıştır. Bu yüzden, AİÇ ve aile kaynaklı duygusal tükenmişlik arasında pozitif bir ilişki olacağını varsayan *Hipotez 6b* reddedilmiştir.

İAÇ ile AİÇ karşı alandaki doyumsal sonuçlar üzerindeki etkisine bakıldığında yine anlamlı sonuçlar elde edilememiştir. Bulgular, İAÇ'nin aile doyumunu üzerinde ($\beta = -.00, p > .05$), AİÇ'nin de iş doyumunu üzerinde ($\beta = -.05, p > .05$) herhangi bir etksi olmadığını göstermiştir. Bu yüzden, İAÇ'nin aile doyumunu düşüreceğini yordayan *Hipotez7* ve AİÇ'nin iş doyumunu düşüreceğini yordayan *Hipotez8* doğrulanamamıştır. Buna karşın, çalışmada önerilmemesine rağmen, İAÇ'nin aile kaynaklı duygusal tükenmişliği olumlu bir şekilde ($\beta = .22$) yordadığı görülmüştür. *Hipotez 9a* ve *9b*'de varsayıldığı üzere iş doyumunun ve aile doyumunun hayat doyumunu ile pozitif ilişkileri olduğu (sırasıyla $\beta = .22, \beta = .61$) saptanmıştır.

İş ve aileye yönelik motivasyonların öncülleri ile iş-aile çatışması sonuçlarının arasındaki ilişkilere bakılacak olduğunda önerilen bütün hipotezlerin veriler aracılığıyla desteklendiği görülmektedir. *Hipotez 10a* ve *10b*'de belirtildiği üzere işlerini motive edici özelliklere sahip olarak gören kişiler işlerinden daha fazla doyum alma ($\beta = .25$) ve daha az tükenmişlik yaşama ($\beta = -.17$) eğilimindedirler. Benzer bir biçimde *Hipotez 11a* ve *11b*'de belirtildiği üzere işyerinde amir ve arkadaşlarından destek gören kişiler işlerinden daha fazla doyum ($\beta = .27$) almakta ve daha az tükenmişlik ($\beta = -.26$) yaşamaktadırlar. Analiz sonuçları, ayrıca, L-M testi buguları göz önünde bulundurularak eklenen işe yönelik özerk motivasyon ve iş doyumunu arasındaki yolun da anlamlı olduğunu ve özerk motivasyonun iş doyumunu olumlu bir biçimde etkilediğini ($\beta = .37$) göstermiştir.

Aile alanına bakıldığında, analizlerin paralel sonuçlar verdiği görülmüştür. Yine *Hipotez 12a* ve *Hipotez12b* önermelerine uygun olarak eş desteğinin ailede doyumuna pozitif ($\beta = .46$), aileye yönelik tükenmişlik duygularına ise negatif ($\beta = -.36$), bir biçimde etki ettiği görülmüştür. Aynı şekilde, *Hipotez 13a* ve *Hipotez 13b* varsayımları ile tutarlı bir biçimde aile hayatına ilişkin olaylara yönelik kontrol algısı yüksek olan kişilerin daha fazla aile doyumunu ($\beta = .22$) ve daha az aileden kaynaklı tükenmişlik yaşadığı ($\beta = -.36$) belirlenmiştir. İş alanında olduğu gibi, L-M testi

sonuçlarına göre eklenen aileye yönelik özerk motivasyon ve aile doyumunu arasındaki yolun pozitif ve anlamlı olduğu ($\beta = .14$) bulunmuştur.

Aracı Analizlerine ve Dolaylı Etkilere İlişkin Bulgular. Modeldeki aracı değişkenleri belirlemek üzere Preacher ve Hayes'in (2005) önerileri takip edilerek dolaylı etkiler yine EQS 6.1. (Bentler ve Wu, 2005) kullanılarak hesaplanmıştır. Modeldeki bütün aracı değişken analizlerin anlamlı olduğu görülmüştür. Beklendiği üzere, işin motive edici özellikleri (MEP) ile iş kaynaklı duygusal tükenmişlik arasındaki ilişkiye, işe yönelik özerk motivasyon ve İAÇ kısmen aracılık etmiştir. Bu bulgu, işlerini motive edici olarak algılayan bireylerin, işe yönelik daha özerk bir motivasyon sergilediklerini, buna bağlı olarak daha az İAÇ yaşadıklarını, ve buna bağlı olarak iş kaynaklı duygusal tükenmişlikten daha az muzdarip olduklarını göstermiştir. Benzer bir şekilde, iş desteği ve iş kaynaklı duygusal tükenme arasındaki ilişkiye de yine işe yönelik özerk motivasyon ve İAÇ kısmen aracılık etmiştir. Yani, iş ortamında daha fazla destek gören bireyler işlerine yönelik daha özerk bir motivasyon sergileme, buna bağlı olarak daha az İAÇ yaşama, ve buna bağlı olarak daha az duygusal tükenmişlik yaşama eğilimindedir.

Yol analizi sonuçları İAÇ'nın ayrıca aile kaynaklı duygusal tükenmişliği yordadığını gösterdiği için, hem iş özelliklerinin hem de iş desteğinin bu değişken üzerinde de dolaylı etkileri olduğu gözlemlenmiştir. Diğer bir deyişle, işlerini daha motive edici olarak algılayan bireyler ve iş ortamını daha destekleyici bulan bireyler, işe yönelik daha özerk bir motivasyon sergilemişler, bunun sonucunda daha az İAÇ rapor etmişler, ve bunun sonucunda daha az aileden kaynaklı duygusal tükenmişlik yaşamışlardır.

Çalışmada iş özellikleri ile iş doyumunu arasındaki ilişkiye hem işe yönelik özerk motivasyonun hem de İAÇ'nin kısmen aracılık edeceği düşünülmekteydi. Ancak İAÇ ve iş doyumunu arasında anlamlı bir ilişki bulunamadığı için bu sayıltı bulgularla desteklenememiş ve İAÇ'nin iş özellikleri ve iş doyumunu arasındaki ilişkide aracı rol oynamadığı bulunmuştur. Ancak, iş özellikleri ile iş doyumunu arasındaki ilişkiye işe yönelik özerk motivasyonun kısmen aracılık ettiği

görülmüştür. Yine aynı nedenle, iş desteği ve iş doyumunu arasındaki ilişkide İAÇ'nin aracı rolü olmadığı görülmüş, bu ilişkiye sadece işe yönelik özerk motivasyonun kısmen aracılık ettiği gözlemlenmiştir. Bu sonuçlar, işlerini daha motive edici olarak algılayan bireylerin ve iş ortamını daha destekleyici bulan bireylerin, işlerine yönelik daha özerk bir motivasyona sahip olduğuna, ve buna bağlı olarak işlerinden daha fazla doyum aldığını işaret etmektedir.

Ayrıca, hem iş özelliklerinin hem de iş desteğinin, işe yönelik özerk motivasyon ve iş doyumunu aracılığı ile hayat doyumuna dolaylı etkileri olduğu saptanmıştır. Yani, işinin motive edici olduğunu düşünen ve iş ortamını destekleyici olarak gören kişiler, işe yönelik daha fazla özerk motivasyon sergilemekte, bunun sonucunda işlerinden daha fazla doyum almakta, ve en nihayetinde hayatlarında da daha fazla doyuma ulaşmaktadırlar.

Analizler, aile alanında da benzer ilişki örüntülerinin olduğunu göstermiştir. Her ne kadar, eşten alınan destek ve aile hayatına ilişkin kişisel kontrol algısından aile doyumuna giden yolun, hem aileye yönelik özerk motivasyon hem de AİÇ tarafından aracılık edilmesi beklense de, AİÇ ve aile doyumunu arasında anlamlı bir ilişki bulunmadığından, bu yolda sadece aileye yönelik özerk motivasyonun aracı rolü olduğu anlaşılmıştır. Sonuçlar, eşlerinden destek gören bireyler ile aile hayatına ilişkin olayların kendi kontrolünde olduğunu düşünen bireylerin, ailelerine yönelik daha özerk bir motivasyon sergilediklerine, ve buna bağlı olarak daha fazla aile doyumunu yaşadıklarına işaret etmektedir.

Ayrıca, iş alanında olduğu gibi, hem algılanan eş desteğinin hem de kontrol düzeyinin aile doyumunu aracılığıyla hayat doyumunu yordadığı bulunmuştur. Bu bulgular, eşlerinden destek gören bireyler ile aile hayatına ilişkin olayların kendi kontrolünde olduğunu düşünen bireylerin, ailelerine yönelik daha özerk bir motivasyon sergilediklerini, ve bunun sonucunda daha fazla aile doyumunu yaşadıklarını, ve neticesinden hayattan daha fazla doyum aldıklarını göstermektedir.

İş ve Aileye Yönelik Motivasyonların Etkileşimli Etkilerine İlişkin Bulgular. İş ve aileye yönelik motivasyonların iş-aile çatışması boyutları üzerindeki etkilerini incelemek ve *Hipotez 2a-2d* önermelerini test etmek için hem İAÇ hem de AİÇ

üzerinde gruplar arası 2 (işe yönelik özerk motivasyona karşı işe yönelik kontrollü motivasyon) x 2 (aileye yönelik özerk motivasyona karşı aileye yönelik kontrollü motivasyon) ANOVA yapılmıştır.

ANOVA İAÇ ve AİÇ için yapıldığında, grupların ortalama değerleri karşılaştırması her ne kadar beklenen örüntüleri verse de, gruplar arası etkileşim analizleri sonuçları işe yönelik ve aileye yönelik motivasyonun hem İAÇ $F(1, 401) = 1.05, p > .05, \eta_p^2 = .003$ hem de AİÇ üzerinde $(F(1, 401) = .62, p > .05, \eta_p^2 = .002)$ anlamlı bir etkileşim etkisinin olmadığını göstermiştir. Bu yüzden *Hipotez 2* ve alt hipotezler *H2a-2d* reddedilmiştir.

İş ve Aile Rollerine İle Özdeşimin Düzenleyici Etkilerine İlişkin Bulgular. *Hipotez 14*'te belirtilen iş rolü ile özdeşimin İAÇ ve aile doyumunu arasındaki ilişkiyi düzenleyeceğine ilişkin sayıtlı ile *Hipotez 15*'te belirtilen aile rolü ile özdeşimin AİÇ ve iş doyumunu arasındaki ilişkiyi düzenleyeceğine ilişkin sayıtlıyı test etmek için Hayes'in (2013) Process Makro Model 1'i kullanılarak SPSS 16.0 programı aracılığıyla düzenleyici regresyon analizleri yapılmıştır.

Öncelikle *Hipotez 14*'te öngörülen İAÇ'nin aile doyumunu üzerindeki olumsuz etkisinin iş rolü ile yüksek seviyede özdeşleşmiş bireylerde iş rolü ile düşük seviyede özdeşleşmiş bireylere göre daha fazla olacağı varsayımı test edilmiştir. Yapılan analizler iş rolü ile özdeşiminin İAÇ-aile doyumunu üzerinde hem doğrudan ($b = .04, S.H. = .07, 95\% G.A. [-.10, .17], t = .572, p > .10$), hem de bir düzenleyici bir etkisinin ($b = .05, S.H. = .06, 95\% G.A. [-.06, .15], t = .842, p > .10$) olmadığını göstermiştir. Bu nedenle, *Hipotez 14* reddedilmiştir.

Hipotez 15'te öngörülen AİÇ'nin iş doyumunu üzerindeki olumsuz etkisinin aile rolü ile yüksek seviyede özdeşleşmiş bireylerde aile rolü ile düşük seviyede özdeşleşmiş bireylere göre daha fazla olacağı varsayımı sınanmıştır. Sonuçlar, aile rolü ile özdeşimin, esnek çalışma saatlerinin etkileri kontrol edildikten sonra bile, iş doyumunu üzerinde hem doğrudan bir etkisinin ($b = .18, S.H. = .09, 95\% G.A. [.00, .36], t = 1.991, p = .05$) olduğunu, hem de AİÇ-iş doyumunu arasındaki ilişkiyi anlamlı bir biçimde düzenlediğini ($b = .22, S.H. = .09, 95\% G.A. [.00, .36], t = 2.498, p < .05, R^2 = .093, R^2_{değişimi} = .014$) göstermiştir.

Ancak, bulgular beklenilenin ve *Hipotez 15* 'te öngörülenin aksine, AİÇ ve iş doyumunu arasındaki negatif ilişkinin yüksek değil, düşük seviyedeki aile ile özdeşim değerinde daha güçlü olduğunu göstermiştir ($b = -.38$, $S.H. = .09$, $95\% G.A. [-.56, -.19]$, $t = -4.016$, $p < .05$). Yüksek aile rolü özdeşim seviyesinde ise AİÇ ve iş doyumunu arasında anlamlı bir ilişki bulunamamıştır ($b = -.06$, $S.H. = .10$, $95\% G.A. [-.25, .12]$, $t = -.688$, $p > .10$). Bu sonuçlar, bireylerin aile rolleri ile yüksek derece özdeşleştiklerinde AİÇ'nin bireylerin iş doyumunu üzerinde herhangi bir olumsuz etkisi olmadığına işaret etmektedir. Ancak, bireyler aile rolleri ile düşük seviyede özdeşleştiklerinde, AİÇ'nin daha olumsuz sonuçlara neden olduğu görülmekte ve bireylerin iş doyumunun düştüğü gözlemlenmektedir. Bu anlamda, *Hipotez 15*'in kısmen desteklendiği söylenebilir.

Tartışma

Çalışmanın Kuramsal Katkıları

Söz konusu çalışmanın mevcut literatüre birçok katkısı olduğu düşünülmektedir. Öncelikle bu çalışma, iş-aile çatışmasının, motivasyonel süreçlerini ÖBK kuramı çerçevesinde araştıran iki çalışmadan biridir (diğeri için bkz. Senecal ve ark., 2001). Ayrıca, bu çalışma (işe ve aileye ilişkin) motivasyonel yönelimlerin AİÇ ve İAÇ boyutları üzerindeki hem tekli hem de birleşik etkilerini inceleyen literatürdeki bilinen tek çalışmadır.

İkinci olarak, bu araştırmada İAÇ ve AİÇ'nin sonuçlarına ilişkin hem *Eşleşme Yaklaşımı* hem de *Karşı Alan Yaklaşımı* tek bir modelde sınanmıştır. İş-aile çatışması boyutları ve önerilen sonuçları arasındaki korelasyonların örüntüsü ve İAÇ'nin iş kaynaklı ve aile kaynaklı duygusal tükenmişlik üzerindeki etkileri incelendiğinde, çalışma bulgularının *Karşı Alan Yaklaşımı*'ndan ziyade, *Eşleşme Yaklaşımı*'ni desteklediği görülmüştür. Bu açıdan çalışmanın bu iki rakip yaklaşım arasında karar verme konusunda araştırmacıları yönlendireceği düşünülmektedir.

Çalışmada hem iş ve aileye yönelik motivasyonların öncüllerini hem de iş-aile çatışmasının temel sonuçlarını içeren bütünleştirici ve kapsamlı bir model öne sürülmüştür. Her ne kadar modelde öne sürülen ilişkilerin bir kısmı geçmişteki farklı

çalışmalar tarafından ayrı ayrı incelenirse de, bilindiği kadarıyla, bu çalışma, söz konusu kavramlar arasındaki ilişkileri tek bir model içerisinde inceleyen yegâne çalışmadır. Ayrıca, öne sürülen model birden çok aracı değişken içermektedir. Çalışmanın, bu değişkenlerin aracı rolleri sınamak suretiyle, ilişkilerin altında yatan mekanizmaları anlamamıza olanak sağladığı düşünülmektedir.

Araştırmanın diğer bir katkısı ise iş ve aile rolleri ile özdeşimin iş-aile çatışması boyutları ile doyumsal sonuçlar arasındaki ilişkilerdeki düzenleyici rollerinin incelenmesine ilişkindir. Söz konusu ilişkileri inceleyen sınırlı sayıdaki çalışmanın (Bagger ve ark., 2008; Bhrowon, 2013; Carr ve ark., 2008; Noor, 2004) şimdiye kadar tutarsız sonuçlar verdiği düşünülecek olduğunda, AİÇ ve iş doyumunun arasındaki ilişkinin aile rolü ile özdeşim tarafından düzenlendiğini göstererek, rol özdeşiminin etkileri konusunda çalışma bulgularının aydınlatıcı olduğu düşünülmektedir.

Uygulamaya Yönelik Çıkarımlar

İAÇ'nin hem iş-kaynaklı hem de aile kaynaklı duygusal tükenmişlikle olan pozitif ilişkisi düşünüldüğünde, kurumların İAÇ yaşantılarını azaltma ve İAÇ'nin çalışanlarının sağlığı üzerindeki etkisini zayıflatma yönünde için adımlar atmaları gerekmektedir. Kurumlarda zaman yönetimi, stres yönetimi, baş etme yöntemleri, çatışma çözme teknikleri ve rahatlama tekniklerine yönelik eğitimlerin verilmesi, çalışanların yaşadıkları rol çatışmalarıyla etkili bir şekilde baş etmelerine ve iş-aile hayatlarında dengeyi bulmalarına yardımcı olabilir.

Korelasyon analizleri sonuçları esnek çalışma saatlerinin İAÇ ve duygusal tükenmişlik ile negatif, iş doyumunu ve özerk motivasyon ile pozitif ilişkili olduğunu göstermiştir. Bu bulgular, çalışanlara esnek mesai saatleri sağlanmasının hem kurum hem de birey açısından önemini vurgulamaktadır. Kurumlar, alternatif olarak, çalışanlarına olarak yoğunlaştırılmış çalışma haftaları, iş paylaşımı, uzaktan iletişim ve evden çalışma gibi seçenekler sunarak, çalışanların ihtiyaçları doğrultusunda işlerini yapılandırmalarına yardımcı olabilirler.

İşe yönelik özerk motivasyonun olumlu etkileri göz önünde bulundurulduğunda, kurumların çalışanların özerk motivasyonunu artırmaya yönelik çaba sarfetmesi gerekmektedir. Çalışma bulguları iş özelliklerinin ve iş desteğinin çalışan motivasyonu üzerinde olumlu etkileri olduğunu göstermektedir. Bu yüzden, işi çalışanları motive edecek bir biçimde yeniden tasarlamak ve destekleyici bir iş ortamı sunmak kurumların amaçları arasında olmalıdır.

Bulgular, klinik alanında çalışan uygulamacılara da öneriler sunmaktadır. Özerk motivasyonun, iş ortamında olduğu gibi, aile ortamında da olumlu sonuçlara yol açtığı görülmektedir. Bu yüzden, terapi süresince bireyin özerk motivasyonunu yükseltmeye çalışmak ve evlilikte temel ihtiyaç doyumunun önemini vurgulamak, danışanın kişisel ve ilişkisel refahını artırma konusunda özellikle aile terapistlerine yardımcı olabilir. Ayrıca, algılanan kontrol düzeyi ve eş desteğinin hem özerk motivasyonu arttırdığı, hem de kişi açısından olumlu sonuçlar doğurduğu düşünüldüğünde, danışanın aile hayatına yönelik kontrol algısını arttırmak ve eşlerin birbirlerine destekleyici tutumlar sergilemesini sağlamak terapi sürecinin ana hedefleri arasında olabilir.

Çalışmanın Kısıtları ve Gelecekteki Çalışmalara Yönelik Öneriler

Çalışmanın en temel kısıtı enine kesit çalışması deseni kullanmasıdır. Her ne kadar çalışmanın hipotezdeki geçmişteki araştırmalara temel alınarak oluşturulmuş ve önerilen ilişkiler yol analizi ile test edilmiş olsa da, değişkenler arasında doğrudan neden-sonuç ilişkisine yönelik çıkarımlar yapılamamaktadır. Bu yüzden gelecekteki çalışmaların boylamsal, deneysel veya zaman-aralıklı desenleri kullanması önerilmektedir.

Çalışmada elde edilen veriler bireylerin kendilerinden alınmış, böylelikle tek kaynaklı bilgi edinilmiştir. Gelecekte, farklı kaynaklardan (amir, iş arkadaşları, ve eş) bilgi toplanmasının, değişkenler arasındaki ilişkilerin yapay olarak artması ihtimalini azaltacağı düşünülmektedir. Özellikle, katılımcıların eşlerinden alınacak verilerin, bireyin yaşadığı iş-aile çatışmasının partnerine yansımaları olasılığına ilişkin aydınlatıcı bilgiler verebileceği düşünülmektedir. Geçmişte yapılan bir çok

arařtırmada (örn., Bakker ve ark., 2008; Cinamon ve ark., 2007; Derya, 2008) bireyin yařadığı bu tarz çatıřmaların eřlerinin iyi oluř halini ve evlilik doyumunu etkilediđi gürülmüřtür.

Çalıřmada ÖBK'nın önermelerinden faydalanarak, iře iliřkin deđiřkenler olan iře özellikleri iře desteđiyle aileye iliřkin deđiřkenler olan eř desteđi ve algılanan kontrolün temel ihtiyaçları karřılamak suretiyle, özerk motivasyonu arttıracığı a priori olarak varsayılmıř, ancak katılımcıların temel ihtiyaç düzeyleri açık bir řekilde ölçülmemiřtir. Bu yüzden ilerideki arařtırmacıların, temel ihtiyaçların doyumuna yönelik ölçümler alması tavsiye edilmektedir.

Arařtırmada önerilen model duygusal tükenmiřlik, iře doyumunu, aile doyumunu ve yařam doyumunu gibi iře-aile çatıřmasında sıklıkla çalıřılan ve geleneksel olarak iře-aile çatıřmasının sonuçları olduđu düşünölen kavramları içermektedir. Ancak, konuyla ilgilenen arařtırmacılar iře-aile çatıřmasının iřten ayrılma niyeti, ebebeyn performansı, ebeveyn-çocuk iliřkisi, iře devamsızlık gibi literatürde daha az çalıřılmıř deđiřkenler üzerindeki etkisini inceleyebilirler.

Son olarak, bu çalıřma bireyin sahip olduđu birden fazla rolün, birey üzerinde olumsuz sonuçlar dođuracağı varsayımına dayanmaktadır. Ancak, kiřilerin sahip olduđu çoklu rollerin bireyin, bir rolde edindiđi bilgi ve becerileri bařka rollerde kullanmasına izin vererek, kiřinin iyi oluř haline katkıda bulunacağını gösteren çalıřmalar da mevcuttur (örn., Barnett ve Hyde, 2001; Byron, 2005; Carlson ve ark., 2014; Eby ve ark., 2005). Bu yüzden, gelecekteki arařtırmacıların iře-aile etkileřimini pozitif açıdan da ele almaları önerilmektedir.

G. TEZ FOTOKOPİSİ İZİN FORMU

ENSTİTÜ

Fen Bilimleri Enstitüsü

Sosyal Bilimler Enstitüsü

Uygulamalı Matematik Enstitüsü

Enformatik Enstitüsü

Deniz Bilimleri Enstitüsü

YAZARIN

Soyadı : Yalçın

Adı : Aslı

Bölümü : Psikoloji

TEZİN ADI (İngilizce) : An Examination Of Work-Family Conflict From
The Self-Determination Theory Perspective

TEZİN TÜRÜ : Yüksek Lisans

Doktora

1. Tezimin tamamından kaynak gösterilmek şartıyla fotokopi alınabilir.
2. Tezimin içindekiler sayfası, özet, indeks sayfalarından ve/veya bir bölümünden kaynak gösterilmek şartıyla fotokopi alınabilir.
3. Tezimden bir (1) yıl süreyle fotokopi alınamaz.

TEZİN KÜTÜPHANEYE TESLİM TARİHİ: