

**A TOKEN BASED CODE DIVISION MULTIPLE ACCESS
MAC PROTOCOL FOR WIRELESS AD HOC NETWORKS**

**M.Sc. Thesis by
Elnur ISAYEV, B.Sc.**

**Department: Computer Engineering
Programme: Computer Engineering**

JANUARY 2009

**A TOKEN BASED CODE DIVISION MULTIPLE ACCESS
MAC PROTOCOL FOR WIRELESS AD HOC NETWORKS**

**M.Sc. Thesis by
Elnur ISAYEV, B.Sc.
(504051542)**

**Date of submission : 25 December 2008
Date of defence examination: 20 January 2009**

**Supervisor (Chairman): Assist. Prof. Dr. Feza BUZLUCA
Members of the Examining Committee Prof. Dr. Emre HARMANCI (İ.T.Ü.)
Assoc. Prof. Dr. Selçuk PAKER (İ.T.Ü.)**

JANUARY 2009

İSTANBUL TEKNİK ÜNİVERSİTESİ ★ FEN BİLİMLERİ ENSTİTÜSÜ

**KABLOSUZ AD HOC AĞLARI İÇİN JETON TABANLI
KOD BÖLÜŞÜMLÜ ÇOK ERİŞİMLİ MAC PROTOKOL**

**YÜKSEK LİSANS TEZİ
Elnur İSAYEV
(504051542)**

**Tezin Enstitüye Verildiği Tarih : 25 Aralık 2008
Tezin Savunulduğu Tarih : 20 Ocak 2009**

**Tez Danışmanı : Yrd. Doç. Dr. Feza BUZLUCA
Diğer Jüri Üyeleri Prof.Dr. Emre HARMANCI (İ.T.Ü.)
Doç.Dr. Selçuk PAKER (İ.T.Ü.)**

OCAK 2009

FOREWORD

I am indebted to my father Abaset and mother Esmira who have been extremely understanding and supportive of my education throughout my life. And to my brother Hasan and sister Gulnar who always cared about me and my future.

I would like to thank my supervisor Assist. Prof. Feza BUZLUCA for his help, support and invaluable guidance during my M.Sc. education period. This could be impossible without his support.

Elnur Isayev

December, 2008

TABLE OF CONTENTS

FOREWORD	ii
ABBREVIATIONS	v
TABLE LIST	vi
FIGURE LIST	vii
SYMBOL LIST	ix
ÖZET	x
SUMMARY	xi
1. INTRODUCTION	1
2. AD HOC NETWORKS	4
2.1 Application Areas	4
2.1.1 Applications Requiring Real - Time Guarantees	5
2.2 Problems in Ad Hoc Networks	6
2.2.1 The Hidden Terminal Problem	7
2.2.2 The Exposed Terminal Problem	7
3. MAC PROTOCOLS	9
3.1 Contention Free Schemes	10
3.1.1 Time Division Multiple Access	11
3.1.2 Frequency Division Multiple Access	12
3.1.3 Code Division Multiple Access	12
3.1.3.1 Code Assignment Protocols	13
3.1.3.2 Spreading-Code Protocols	13
3.1.4 Token Based MAC Scheme	14
3.2 Contention-Based Schemes	16
3.2.1 Multiple Access Collision Avoidance	17
3.3 Code Division Multiple Access Based MAC Schemes	19
3.3.1 Time Division Based Schemes	20
3.3.2 Frequency Division Based Schemes	21
4. A TOKEN BASED CODE DIVISION MULTIPLE ACCESS MAC PROTOCOL	22
4.1 IEEE 802.11 Power Saving Mechanism	22
4.2 Topology of the Network	23
4.2.1 Station and Token Structure	24

4.2.2 Channel Access Control	26
4.2.3 Channel Access Order	29
4.3 Dynamic Topology	31
4.3.1 Station Entering Routine	31
4.3.2 Station Lost Routine	33
4.3.2.1 Leave on Demand	33
4.3.2.1 Sudden Death	34
5. SIMULATION ENVIRONMENT AND RESULTS	35
5.1 System Architecture	35
5.2 The Network and Message Model	36
5.3 Theoretical Background	37
5.4 Development Environment	39
5.5 Performance Analysis	39
6. CONCLUSION	60
6.1 Future Work	61
REFERENCES	63
APPENDIX A	67
BIOGRAPHY	70

ABBREVIATIONS

IEEE	: Institute of Electrical and Electronics Engineers
FDDI	: Fiber Distributed Data Interface
QoS	: Quality of Service
3G	: Third Generation Networks
CDMA	: Code Division Multiple Access
TDMA	: Time Division Multiple Access
FDMA	: Frequency Division Multiple Access
CSMA	: Carrier Sense Multiple Access
CSMA/CD	: Carrier Sense Multiple Access Collision Detection
CSMA/CA	: Carrier Sense Multiple Access Collision Avoidance
MACA	: Multiple Access Collision Avoidance
RTS	: Request to Send
CTS	: Clear to Send
WSN	: Wireless Sensor Networks
WMSN	: Wireless Multimedia Sensor Networks
WICN	: Wireless Industrial Control Networks
PSM	: Power Saving Mechanism
MUD	: Multiple User Detection
ATIM	: Ad Hoc Traffic Indication Message
TTP	: Token Travelling Period
FSM	: Finite State Machine

TABLE LIST

	<u>Page No</u>
Table 4.1	Structure of the Station List.....25
Table 4.2	The structure of the token.....25
Table 4.3	Token structure in system which has a MUD hardware34
Table 5.1	The structure of the token in two transceiver based MAC scheme39
Table 5.2	System Parameters (Increasing code numbers)40
Table 5.3	Practical results for one transceiver based MAC scheme (Increasing code numbers)42
Table 5.4	Practical results for two transceiver based MAC scheme (Increasing code numbers)42
Table 5.5	System Parameters (Increasing load, packet size is 11,25 KB).....47
Table 5.6	Practical results for one transceiver based MAC scheme (Increasing load, packet size is 11,25 KB).....48
Table 5.7	Practical results for two transceiver based MAC scheme (Increasing load, packet size is 11,25 KB).....49
Table 5.8	System Parameters (Increasing load, packet size is 128 KB)49
Table 5.9	Practical results for two transceiver based MAC scheme (Increasing load, packet size is 128 KB).....50
Table 5.10	Practical results for one transceiver based MAC scheme (Increasing load, packet size is 128 KB).....50
Table 5.11	System Parameters (Increasing load, packet size is 3,375 KB).....52
Table 5.12	Practical results for two transceiver based MAC scheme (Increasing load, packet size is 3,375 KB).....52
Table 5.13	Practical results for one transceiver based MAC scheme (Increasing load, packet size is 3,375 KB).....53
Table 5.14	System Parameters (Increasing code numbers)55
Table 5.15	Practical results for system which has MUD hardware (Increasing code numbers)55
Table 5.16	Practical results for system which doesn't have MUD hardware (Increasing code numbers)55
Table 5.17	System Parameters (Increasing load, packet size is 11,25 KB).....57
Table 5.18	Practical results for normal ordering (Increasing load, packet size is 11,25 KB).....58
Table 5.19	Practical results for special ordering (Increasing load, packet size is 11,25 KB).....58

FIGURE LIST

	<u>Page No</u>
Figure 2.1 : The hidden terminal problem.....	7
Figure 2.2 : The exposed terminal problem	8
Figure 3.1 : Classifications of MAC schemes	10
Figure 3.2 : Time Division Multiple access	11
Figure 3.3 : Frequency Division Multiple access	12
Figure 3.4 : Code Division Multiple Access	13
Figure 3.5 : A primary collision scenario.....	14
Figure 3.6 : Solving the hidden-terminal problem using RTS-CTS handshake.....	17
Figure 3.7 : Solving the exposed-terminal problem using RTS-CTS handshake..	18
Figure 3.8 : Failure of RTS-CTS mechanism in solving Hidden and Exposed terminal problems	19
Figure 3.9 : Illustration of time based MAC scheme.....	20
Figure 3.10 : Reserving CDMA code for data transferring.....	20
Figure 4.1 : IEEE 802.11 power saving mode.....	23
Figure 4.2 : Proposed token based CDMA Mac protocol.....	24
Figure 4.3 : Illustration of the token travelling on the virtual ring	24
Figure 4.4 : Illustration of broadcasting requirement	27
Figure 4.5 : Channel list	28
Figure 4.6 : Illustration of detailed working of proposed MAC scheme	30
Figure 4.7 : Finite State Machine	31
Figure 4.8 : Illustration of node Welcome message	32
Figure 5.1 : Maximum packet delay (Increasing code numbers)	43
Figure 5.2 : Average packet delay (Increasing code numbers)	44
Figure 5.3 : Time duration for transmitting all packets (Increasing code numbers)	44
Figure 5.4 : Structure of the C_List field in two transceiver based MAC scheme	45
Figure 5.5 : Illustration of scenario where CDMA code is unusable	46
Figure 5.4 : Maximum Packet Delay (Increasing load, packet size is 11,25 KB).	47
Figure 5.5 : Average Packet Delay (Increasing load, packet size is 11,25 KB)....	48
Figure 5.6 : Time duration for transmitting all packets in the network (Increasing load, packet size is 11,25 KB).....	49
Figure 5.7 : Maximum Packet Delay (Increasing load, packet size is 128 KB)....	51
Figure 5.8 : Average Packet Delay (Increasing load, packet size is 128 KB).....	51
Figure 5.9 : Time duration for transmitting all packets in the network (Increasing load, packet size is 128 KB).....	52
Figure 5.10 : Maximum Packet Delay (Increasing load, packet size is 3,375 KB).	53
Figure 5.11 : Average Packet Delay (Increasing load, packet size is 3,375 KB)....	54
Figure 5.12 : Time duration for transmitting all packets in the network (Increasing load, packet size is 3,375 KB).....	54
Figure 5.13 : Maximum Packet Delay (Increasing code numbers, comparing systems with a MUD hardware and without a MUD hardware).....	56

Figure 5.14	: Average Packet Delay (Increasing code numbers, comparing systems with a MUD hardware and without a MUD hardware)	56
Figure 5.15	: Time duration for transmitting all packets in the network (Increasing code numbers, comparing systems with a MUD hardware and without a MUD hardware)	57
Figure 5.16	: Maximum Packet Delay (Increasing load, comparing systems which uses normal ordering method for channel access order and which uses special ordering method for channel access order)	59
Figure 6.1	: Multi Ring Network Topology	62

SYMBOL LIST

T_i^{trans}	: Time taken to transmit the token from station i to its successor station $i+1$
T_c	: Time taken by the token to travel all stations in the virtual ring
T_T	: Token period duration
T_T^{mud}	: Token period duration in systems which have a MUD hardware
T_P	: Data transfer period duration
T_{SL}	: Time taken to broadcast STATION_LIST to all stations in the network
T_{NW}	: Time taken to broadcast NODE_WELCOME message and insert a new joined station to the network
T_{max}	: Maximum waiting time for a station to access the channel
S_i	: Stream of synchronous messages
C_i	: Size of the packet in the stream i
D_i	: Deadline of the packet in the stream i
P_i	: Period between packets in the stream i
S_{PM}	: Size of the PM header
C_S	: Channel speed

KABLOSUZ AD HOC AĞLARI İÇİN JETON TABANLI KOD BÖLÜŞÜMLÜ ÇOK ERİŞİMLİ MAC PROTOKOL

ÖZET

Kablosuz mobil düğümlerden oluşan kablosuz Ad Hoc ağları, önceden belirlenmiş olan bir alt yapıya ihtiyaç duymadan, geçici ve isteğe bağlı olarak herhangi bir dinamik topoloji oluşturabilir. Ad Hoc ağlarında en mühim konulardan biri MAC protokol tasarımıdır. Bilindiği gibi, MAC protokollerin başlıca fonksiyonu, olabilecek çarpışmaları mümkün olduğunca azaltmak ve uygun kanal kullanımını sağlamaktır. Ayrıca MAC protokoller adil olmalı ve düğümlerin önceliklerine göre kanal erişim sırasını ayarlamalıdır. Bu yüzden, TDMA, FDMA, CDMA, Jeton ve Oy verme (Polling) yöntemlerine dayanarak bu alanda pek çok araştırmalar yapılmaktadır.

Gerçek zaman iletişimini sağlamak için en uygun olan protokoller jeton yöntemine dayanmaktadır. Bu tip protokollerde paket gecikmeleri deterministiktir ve olabilecek en büyük paket gecikmeleri tahmin edilebilmektedir. Böylece gerçek zaman iletişimi için jeton yöntemini kullanan MAC protokoller, IEEE 802.11 standartlarından daha avantajlıdır ve kablosuz ağ araştırmacıları tarafından büyük ilgi görmektedir.

Bu çalışmada ileri sürülen MAC protokol de bir çok MAC protokol gibi jeton yöntemine dayanmaktadır, fakat bu çalışmada jeton CDMA kodlarını ağda paylaşmak için kullanılmaktadır. CDMA özelliği protokole, ağda aynı anda birden çok yayın yapabilmesini sağlamaktadır. Önerilen protokol literatürde adı geçen protokolle karşılaştırılmıştır ve simulasyon sonuçları, önerilen protokolün paket gecikmelerini azaltmakta ve kanal kullanımını artırmakta olduğunu göstermiştir.

A TOKEN BASED CODE DIVISION MULTIPLE ACCESS MAC PROTOCOL FOR WIRELESS AD HOC NETWORKS

SUMMARY

A wireless ad hoc network consists of wireless nodes that can dynamically self-organize into an arbitrary and temporary topology to form a network without necessarily using any pre-existing infrastructure. MAC protocols are very important issues in wireless ad hoc networks. As known, its primary function is to minimize the collisions and achieve reasonable channel utilization. Also MAC protocols must support fairness and prioritized access to the medium, so there are many studies in this area; based on TDMA, CDMA, FDMA, polling and token.

Token based MAC schemes are more suitable for real time communications due to the fact that the packet delay is highly deterministic and upper bound of latency is predictable, so token passing MAC protocols provide advantages over the existing IEEE 802.11 standards by means of real-time guarantees. They are gaining more interest among wireless ad hoc network researchers.

The proposed work in this thesis is based on a token passing scheme as many studies have proposed till now, but the difference is that this MAC scheme is based on a token passing scheme with the incorporation of a Code Division Multiple Access (CDMA) unlike others. The protocol is able to support multiple, simultaneous transmissions with it is unique CDMA feature. Nodes are equipped with only one transceiver. The performance of proposed MAC protocol is compared with MAC protocols that have appeared in the literature by simulations. Simulation results show that proposed MAC scheme is effective in decreasing the packet delay and increasing the channel utilization.

1. INTRODUCTION

A wireless ad hoc network consists of mobile hosts and can be rapidly deployed without any established infrastructure or central administration. Therefore, wireless ad hoc networks have received growing attention in the past few years. Medium Access Control (MAC) is a very challenging task in ad hoc networks. It is very difficult to design a MAC protocol which increases the overall network throughput and fully utilizes the limited wireless resources (e.g., bandwidth, batteries, etc.).

Wireless ad hoc networks mostly use MAC protocols based on modified Carrier Sense Multiple Access Collision Detection (CSMA/CD) scheme [1]. There is a general problem in wireless ad hoc networks such as hidden terminal problem. There is no guarantee in wireless ad hoc networks that some terminals may not be hidden from the other terminals. Therefore, the performance in MAC protocols which based on CSMA scheme is degraded, because of hidden terminal problem [2]. To solve the problem many protocols use control packets such as Request to Send (RTS)/Clear to Send (CTS) handshakes [3-6]. The proposed MAC schemes still suffer from high packet collision probability under heavy traffic load due to the characteristics of RTS/CTS [6].

Token-passing MAC schemes (e.g. IEEE 802.5 [7], FDDI [8]) outperform CSMA schemes [1, 6] and it is well known that they are the best reliable MAC schemes in the industry. The virtual-ring topology has many advantages such as robustness against single node failure and support for flexible topologies. It is shown in papers [9- 11] that when using virtual-ring topology in ad hoc networks, these advantages can be usable. Because of reliability of token-passing schemes and advantages of virtual-ring topology, token-passing medium access protocols for ad hoc networks are getting more attention in recent years. Token passing schemes in wireless networks are achieving higher channel utilization than CSMA type schemes [12] and are also capable of including quality-of-service (QoS) guarantees, therefore research has focused on these schemes [2].

The existing MAC schemes for ad hoc networks rarely provide QoS guarantees, but there are some MAC protocols that use token-based design with QoS guarantees for ad hoc networks [13-16].

The general MAC operation is the same in these protocols. A single token is generated for each network. The stations in each network are serviced when they get the token, and the stations get the service in a fixed and predetermined cyclic order. These schemes include QoS guarantees by giving delay bounded or bandwidth services. Some papers that use a wireless token-ring network has only one traffic type and supports no multiple transmissions [13-15].

There are some disadvantages of these proposed token passing MAC schemes. The main disadvantage is that they don't discuss the wireless aspect of ad hoc networks. It is known that a wireless link is much more suffering from error than cable-based links. Corruption of data results in link layer retransmission, and decreases the bandwidth efficiency which results in bad performance from upper layers in the OSI model. The errors in wireless links are caused by multipath fading, path loss, co and adjacent channel interference, man-made interference, dynamic topology, station mobility, partial connectivity and channel noise [17, 18]. Wireless channel interference in the wireless token passing MAC network was discussed in [19]. It was discovered that token passing MAC is weak to channel errors. The protocol stability is severely hindered by the loss of a token due to interference; as a result the utilization of the network bandwidth is reduced.

Unlike conventional token passing MAC schemes, a hybrid token-CDMA MAC scheme which includes Code Division Multiple Access (CDMA) mechanism is proposed in [20]. This MAC scheme combines the advantage of guarantee-access characteristic of the token passing mechanisms and the supportability of multiple packet transmissions within the network with the incorporation of QoS guarantee for different classes of traffic. There exist many papers that implement the CDMA system in ad hoc networks [21-25]. However, the most of them still use RTS/CTS handshake approach, while none of them use the hybrid token-CDMA technology.

In this thesis a hybrid token-CDMA MAC scheme is also proposed, but the difference between this protocol and the protocol proposed in [20] is that there is no need for an extra hardware as a transceiver and Multiple User Detection (MUD)

which decreases the hardware cost. The proposed MAC scheme can work with or without MUD hardware and with one transceiver for each node. The MAC scheme in [20] is based on frequency division based scheme but the proposed work is based on time division based scheme.

The thesis is organized as follows.

In Section 2, a brief introduction to Wireless Ad Hoc Networks is given. The problems in Ad Hoc Networks as hidden terminal problem and exposed terminal problem are shortly introduced. Some examples of Ad Hoc Network Applications are also given in this section. Medium Access Control Protocols (Contention-free and contention based schemes) for Ad Hoc Networks is discussed in detail in Section 3. Description of the related work and elaboration of our contributions are given in Section 4. Section 5 includes information about the simulation environment and input/output interface of the simulation. Moreover, brief information is given about the implementation of the simulation and simulation results are depicted for visual assistance.

Finally, conclusions and future work are discussed in Section 6.

2. AD HOC NETWORKS

Wireless networks are especially being used in industrial automation applications mainly in the areas where it is either difficult or expensive to wire. Usually wireless networks are extensions to the Ethernet segments in these networks. Since there are no physical restrictions in wireless networks like wires, nodes in wireless networks also can be mobile.

The use of wireless networks in the communication among devices of the most varied types and sizes are being attractively increased. Personal computers, handhelds, telephones, appliances, industrial machines, sensors, and others are being used in several environments, such as residences, buildings, cities, forests, and battlefields. To enable easy deployment of applications different wireless network standards and technologies have appeared in the last years.

It can be difficult to deploy wireless networks in places where there is no infrastructure or where the infrastructure is not reliable. In order to solve such problems ad hoc networks have been proposed. A wireless ad hoc network can dynamically self-organize into an arbitrary and temporary topology to form a network without necessarily using any pre-existing infrastructure. Nodes in ad hoc networks act as a router, so that each node may communicate directly to each other. The nodes which are not connected directly communicate by forwarding their traffic through intermediate nodes. As a result of these properties of wireless ad hoc networks, it can be said that usage of wireless Ad Hoc networks will gain popularity in the future.

2.1 Application Areas

The main advantages of ad hoc networks are flexibility, low cost, and robustness. Ad hoc networks can be used in many new applications [26, 27] given below. It is possible that existing communication infrastructure is destroyed by natural or other disasters. In such situations, an ad hoc wireless network can be set up almost

immediately to provide emergency communication in the affected region. Another application is mobile computing environment, mobile wireless devices that have the capability to detect the presence of existing networks can be used to synchronize data with the user's conventional desktop computers automatically, and download appointment/schedule data. A user carrying a handheld Personal Digital Assistant (PDA) device can download context sensitive data in a shopping mall or museum featuring such wireless networks and services. The PDA can detect an existing network and connect itself to network in an ad hoc fashion. Depending on user's mobility, the PDA can elect the network for related information based on its current position. For example, if the user is moving through the cinema section of the shopping centre, information about films or pricing can be made available. Similarly, ad hoc networks can be used in travel-related and customized household applications, telemedicine, virtual navigation, etc.

Generally the carried data is small like a vital control or monitoring information or sometimes is large like log files or other event logs. Much of the status or control information is carried in short bursts which require little bandwidth. The traffic is usually periodic in this type of data. The key requirement for this type of communication in ad hoc networks is timely delivery without failure.

2.1.1 Applications Requiring Real - Time Guarantees

Many wireless military networks have been proposed like Wireless Sensor Networks (WSN) or experimental cellular and short range Third Generation Networks (3G) networks. Technological advances in wireless devices provide long range communication capabilities and mobility. Because of these advantages, a wireless system is very attractive in military applications. So wireless military networks are increasingly gaining great importance, and as a result number of wireless military network deployments are increasing. The main issues in wireless military networks are actually the real-time guarantees of the stations in the network and secure communications. Many new applications are being considered, due to increasing data rates of wireless communication. For example, a robot in a battlefield can take photos of enemy actions and can transmit this information to a center to be processed for further action.

These multimedia applications are being used today and will also be used extensively in the future. To provide the quality of service in this type of networks, specialized real-time commands and quality of service aware network protocols must be designed.

It has been large research in WSN in recent years. WSNs are being used by many applications like habitat monitoring, object tracking, traffic monitoring and etc. With the availability of low-cost devices (which can capture multimedia content from the field) like small-scale imaging sensors, CMOS cameras and microphones, Wireless Multimedia Sensor Networks (WMSN) have been proposed and are getting increasing attention from the researchers. For these types of applications (multimedia surveillance networks, target tracking, environmental monitoring, traffic management systems) effective communication is needed. Carried data in these systems is multimedia such as audio, image and video. So the real-time guarantees must be provided in WMSN, which is a new challenge topic for researchers [28].

2.2 Problems in Ad Hoc Networks

There are several interesting and difficult problems in the wireless ad hoc networks related to the physical medium, such as low transmission rate, high bit error rates, noise, limited range, and significant variation in physical medium conditions. Wireless medium has a very limited channel bandwidth that is typically much less than that of wired networks. In addition, the wireless medium is essentially error prone. Even though a radio may have sufficient channel bandwidth, factors such as multiple accesses, signal fading, noise and interference can cause the effective throughput in wireless networks to be significantly lower. The network topology can change frequently without any predictions because of nodes' mobility. Usually the links between nodes would be bi-directional, but there may be unidirectional links due to transmission power. The batteries are critical issues in ad hoc networks, so it must conserve energy. The security issues should be considered in the overall network design, as it is relatively easy to eavesdrop on wireless transmission.

Besides, there are some problems in Ad hoc networks such as difficulty of collision detection, the hidden and exposed terminal problems.

2.2.1 The Hidden Terminal Problem

The most known MAC scheme for wired networks is Carrier Sense Multiple Access (CSMA) [29] MAC scheme. This MAC scheme and its variations such as CSMA with collision detection cannot be used in the wireless networks, as explained below. In CSMA, a station that has data to send first senses the medium to check whether it is idle or busy. If a station senses a carrier in the medium as considered busy then the station postpones its data transfer. Otherwise, the station transmits its data immediately while continuing to sense the medium. Unfortunately, collision detection is not possible in free space. Thus, a successful data transmission is not guaranteed because stations may not sense collisions at the receiver. This problem is known as the hidden terminal problem [2], which is shown in Figure 2.1.

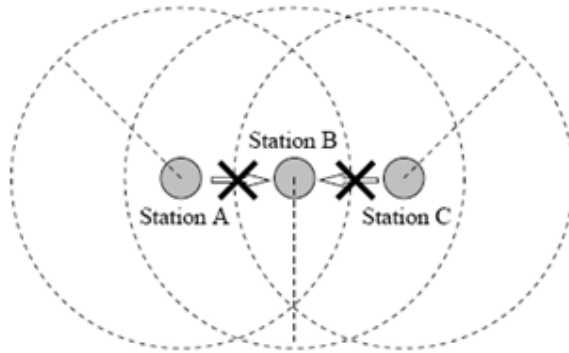

Figure 2.1: The Hidden Terminal Problem

In this figure, each station centers a dotted circle that represents its own transmission range. As illustrated in Figure 2.1, station B is within transmission range of stations' A and C, but station A and station C are not in each other's transmission range. Consider the case where station A is transmitting to station B. Station C cannot detect carrier because it is out of station A's transmission range. Therefore station C transmits data to station B, thus causing a collision at station B.

2.2.2 The Exposed Terminal Problem

Consider another case where station B is transmitting data to station A and station C has data to send to station D as shown in Figure 2.2

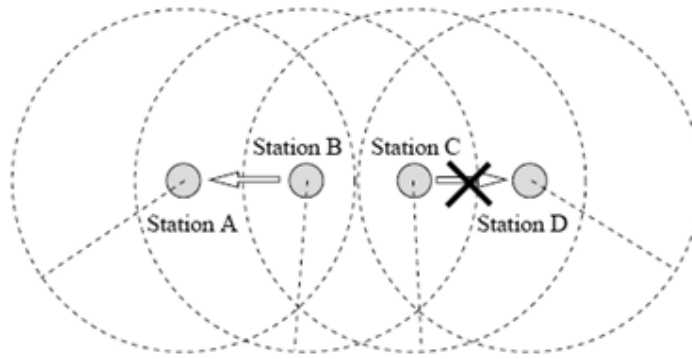

Figure 2.2: The Exposed Terminal Problem

Since station C is in the station B's transmission range, it sense carrier and decides not to send data, and postpones its transfer. However it is unnecessary because there is no way that station C's transmission can cause any collisions at receiver station A. This problem is known as exposed-terminal problem [2].

The difficulty of collision detection, the hidden and the exposed terminal problems in the MAC sub layer demand new medium access algorithms for wireless networks. The status of communication links between the stations may vary because of stations mobility, so the routing protocols for wired networks are not usable in wireless ad hoc networks. At the transport layer, TCP-like transport protocols also present several problems when used on wireless networks. High bit-error rates and frequent route failures reduce TCP performance, demanding modifications to TCP or the design of new transport protocols.

3. MAC PROTOCOLS

Many new standards and technologies have been proposed in both the academia and the industry due to tremendous research in the field of wireless local area networking. These technologies and standards made high data rate and more reliable wireless communications possible for both mobile and fixed devices. Different communication requirements such as video or voice communication over wireless links are appeared with technological advances. The main issues for these multimedia applications are quality of service guarantees such as delay, bandwidth, jitter and minimal packet loss. To provide these requirements, quality of service (QoS) aware protocols for wireless networks must be developed.

The wireless networks are actually defined in the physical and data link layers of the OSI model. So enabling QoS in wireless networks requires QoS aware protocols in the data link layer and the physical layer of the OSI model. As known, data link layer is divided into two sub layers namely Logical Link Control sub layer and Medium Access Control sub layer according to the IEEE 802 family of standards.

MAC sub layer is responsible for transferring data between two or more nodes of the network. It is MAC sub layer's duty to manage error correction in the physical layer. The sub layer performs specific activities for framing, physical addressing, and error controlling. Managing conflicts among different nodes for channel access is also its job. It affects the QoS of the network, because the question how reliable and efficiently data can be transmitted between two nodes along the routing path is MAC sub layer's responsibility.

In order to understand the proposed MAC scheme in this thesis it will be helpful to review the MAC techniques. MAC schemes can be classified as contention-free and contention-based schemes, depending on the medium access strategy [30] which is illustrated in Figure 3.1.

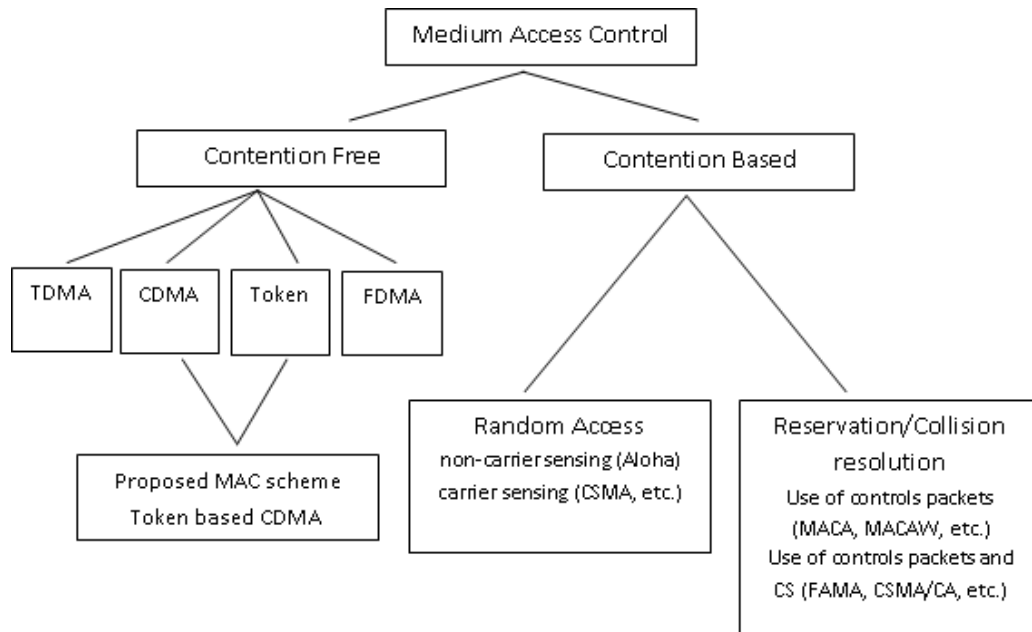

Figure 3.1: Classifications of MAC Schemes

In the contention free schemes stations are allowed to transmit without contending for the medium (e. g., TDMA, CDMA, FDMA, polling and token-based). Contention-free mechanisms provide bounded end-to-end delay and minimum bandwidth, prevailing delay sensitive applications such as audio and video streams. On the other hand, contention-based schemes are more suitable for sporadic data transfer on mobile networks because of the random and temporary nature of the topologies.

3.1 Contention Free Schemes

Contention free MAC protocols should be able to bring the network from an arbitrary state to a collision free stable state. These MAC schemes are known as deterministic protocols, and the main service for these schemes is to carry data such as voice or video traffic. As shown in Figure 3.1, Time Division Multiple Access (TDMA), Frequency Division Multiple Access (FDMA), Code Division Multiple Access (CDMA) and Token Based protocols are examples for contention free schemes. Brief description of these protocols is given below.

3.1.1 Time Division Multiple Access

In TDMA the channel is divided into N time slots, as shown in Figure 3.2.

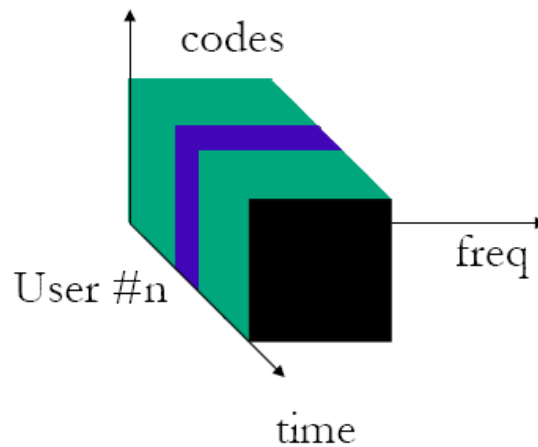

Figure 3.2: Time Division Multiple Access

In each slot only one node is allowed to transmit. The N slots comprise a frame, which repeats cyclically. TDMA is frequently used in cellular wireless communication systems, such as Global System for Mobile Communications (GSM). A base station allocates time slots and provides timing and synchronization information to all mobile nodes within each cell. Typically mobile nodes communicate only with the base station. There is no peer-to-peer communications between mobile nodes. The main advantage of TDMA is its energy efficiency, because it supports low-duty-cycle operations of nodes. However, TDMA has some disadvantages, such as it normally requires nodes to form clusters. One node in each cluster is selected as cluster head, and acts as the base station. Nodes are normally restricted to communicate with the cluster head within a cluster; peer-to-peer communication is not supported (if nodes communicate directly, then they must listen during all slots reducing energy efficiency). Inter-cluster communications and interference need to be handled by other approaches, such as FDMA or CDMA. More importantly, TDMA protocols have limited scalability and adaptively to the changes on number of nodes.

3.1.2 Frequency Division Multiple Access

FDMA is a technique in which the carrier bandwidth is divided into N sub-channels of different frequency widths. Each sub channel can carry a signal at the same time in parallel to other channels as shown in Figure 3.3.

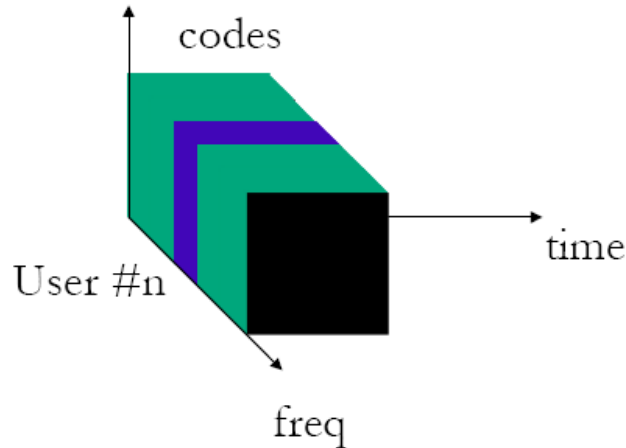

Figure 3.3: Frequency Division Multiple Access

TDMA and CDMA are always used in combination with FDMA, i.e., a given frequency channel may be used for either TDMA or CDMA independently of signals on other frequency channels.

3.1.3 Code Division Multiple Access

CDMA is based on Spread Spectrum (SS) techniques, in which each user occupies the entire available bandwidth. At the transmitter, a digital signal of bandwidth say B_1 bits/s, is spreading using (i.e., multiplied by) a Pseudo-random Noise (PN) code of bandwidth, say B_2 bits/s ($B_2/B_1 \gg 1$ is called the processing gain). The PN code is a binary sequence that statistically corresponds to the requirement of a random sequence. This PN code must be exactly reproduced at the intended receiver to get the digital signal. To recover the original information from the signal, the receiver de-spreads the received signal using a locally generated PN code. It is possible for several, independently coded signals to occupy the same channel bandwidth, as shown in Figure 3.4, provided that each signal has a distinct PN code. Therefore the performance is growing up with spread spectrum technique. This type of communication in which each transmitter-receiver pair has a distinct PN code for transmitting over a common channel is called Code Division Multiple Access [25].

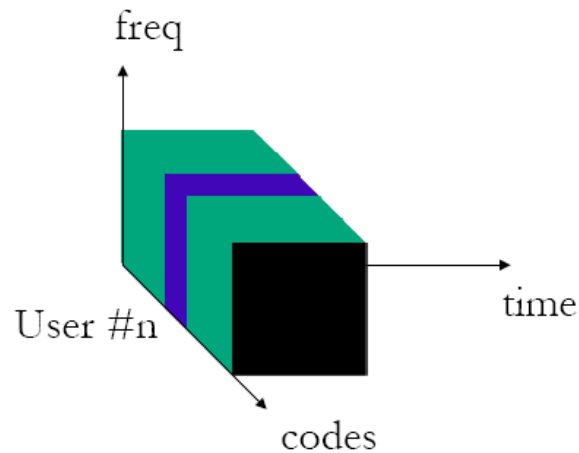

Figure 3.4: Code Division Multiple Access

CDMA has been the access technology of choice in cellular systems, including recently adopted 3G systems due to its useable characteristics [31]. It is shown that CDMA provides up to six times capacity of TDMA or FDMA-based solutions in such systems [32]. This throughout gain brings some desirable features such as signal degradation, multipath resistance, inherent frequency diversity, and interference rejection.

The main issues in CDMA schemes are code-assignment and spreading-code protocols. So the brief description of these protocols is described below.

3.1.3.1 Code Assignment Protocols

To enable CDMA-based solutions for ad hoc networks is very challenging, because of the absence of centralized control (i.e., a base station). There is a need for a code assignment protocol to assign distinct codes to different terminals. This problem is trivial in small networks, but becomes serious in large networks where the number of PN codes is smaller than the number of terminals, necessitating spatial reuse of the PN codes. There are several code assignment protocols, in general these protocols attempt to assign codes to nodes that all neighbors of a node have different PN codes [33].

3.1.3.2 Spreading-Code Protocols

Besides the code assignment protocol, a spreading-code protocol is also needed to decide which codes to use for packet transmission and for monitoring the channel in anticipation of packet reception [34]. Spreading-code protocols can be classified as

receiver-based, transmitter-based, or a hybrid. In a receiver-based protocol, the transmitter uses the receiver code to spread the packet, while an idle terminal constantly monitors its own code. This method simplifies the receiver job in which the receiver doesn't have to monitor the whole code set. Receiver-based approach has some disadvantages such as primary collision (two or more transmissions are spread using the same code). Even under correct code assignment, collisions may occur. For example node A and C are non-neighboring nodes as shown in Figure 3.5. These nodes have distinct codes, and they have a common neighbor B with its own code. A primary collision occurs when nodes A and C simultaneously attempt to transmit to node B using B's code.

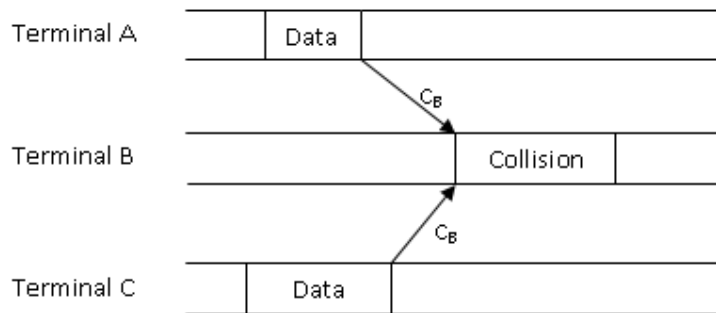

Figure 3.5: Primary Collision Scenario

The primary collisions can be overcome by using different codes for different, concurrently transmitted signals (not nodes). Another disadvantage of this method is that a broadcast requires the transmitter to unicast the message to each receiver. In a transmitter-based spreading protocol, a transmission code is assigned to each terminal, and receivers continuously monitor the whole set of PN codes to receive a signal. The advantages of this method are that primary collisions cannot happen and broadcast is supported. But the disadvantage of the transmitter-based approach is that the receiver's job is very complex and expensive. Various hybrids of the above two approaches are also possible. The common-transmitter-based protocols and the receiver-transmitter-based protocol which are proposed in [34] can be given as examples.

3.1.4 Token Based MAC Scheme

Token based MAC schemes are designed to provide high throughput under heavy loads but most importantly it is a deterministic multiple access technique. This means

that it is always possible to define the maximum access delay experienced by a frame and thus to define the worst case end-to-end delay across the network.

In these schemes the token cycles around the stations, along the virtual ring topology, giving each station equal opportunity to access the channel. Multiple access to the channel is provided by restricting the time for which a station can keep the token. The transmission of data in token passing systems requires that the transmitting station has possession of the token. Data transmission is then permitted until the holding period has expired, at which point the token must be transmitted to the next station in the virtual ring. Since every station releases the token after it transmits the packet for a specified amount of time, every other station in the virtual ring has a chance to get permission to transmit data before a station can make its second transmission. This mechanism leads to fairness in these MAC schemes. The algorithm for data transmission in token based MAC schemes can be explained as below.

- When the station has data to transmit, it waits until it gets a token. The token cycles around the virtual ring continuously.
- The token priority is inspected and if it is bigger than or equal to that of the station's data then it is altered to start transmission. The data frame is constructed and transmitted synchronously.
- After all of the frame is transmitted, if the token holding time (THT, which is the period allotted to each station for data transmission each time it gains possession of a token) has not expired and more data is queued for transmission which transmission will not exceed the THT, then this data can also be sent.
- After the data transmission, the token is transmitted to the neighbor station in the virtual ring.

The most important advantage of token based MAC schemes unlike other MAC schemes is that the response time is highly deterministic and also the upper bound of the latency is predictable.

Another important advantage of token based MAC schemes is that the collision problem is solved since each station gets permission to transmit after it gets the

token. So the plenty of retransmissions caused by collisions is not an issue in this schemes.

The other important advantage of this scheme is fairness. In token based schemes the token is usually passed linearly such that when the station i holds the token, it passes the token to its sucesor station $i+1$. So this working mechanism of the token provides fariness to token based MAC schemes.

3.2 Contention-Based Schemes

Contention based MAC schemes can be classified as random access protocols like ALOHA, Slotted ALHOA, Carrier Sensing Multiple Access (CSMA) and dynamic reservation/collision resolution protocols like Multiple Access Collision Avoidance (MACA), Multiple Access Collision Avoidance for Wireless (MACAW), Floor Acquisition Multiple Access (FAMA), CSMA/CA (collision avoidance). In reservation systems each cycle begins with a reservation period and each station makes a reservation request for accessing the medium in this period. In random access based schemes, such as ALOHA, a node transmits data as soon as it has. Naturally, more than one node may transmit at the same time, so the collisions will occur. If the system is low loaded with large number of potential senders then the ALOHA is suitable for this type of systems and offers relatively low throughput. To increase the throughput a variations of ALOHA known as Slotted ALOHA was introduced. In the Slotted ALOHA, a station waits for the beginning of a pre-defined interval of time to start its transmission. The introduced time slots doubles the throughput as compared to the pure ALOHA scheme, but adds the necessity of synchronization. In addition, the CSMA-based schemes reduce the probability of collisions and improve the throughput. There are many contention-based MAC protocols based on solving the hidden and exposed terminal problems in CSMA. Some researchers use the Request-to-Send/Clear-to-Send (RTS/CTS) control packets to prevent collisions [3, 35]. Others use a combination of carrier sensing and control packets [36, 37].

To understand how the hidden and exposed terminal problem can be solved using the Request-to-Send/Clear-to-Send (RTS/CTS) control packets, detailed working of Multiple Access Collision Avoidance (MACA) [3] protocol is described below.

3.2.1 Multiple Access Collision Avoidance (MACA)

To overcome the hidden and exposed terminal problems in CSMA-based protocols, MACA protocol [3] uses two short signaling packets (RTS/CTS) similar to the Apple Talk protocol [38]. As shown in Figure 2.1, if node A has data to transfer to node B, it first sends an RTS packet to node B. This RTS packet involves the length of the data transmission that would later happen. If node B receives this RTS packet and agrees to receive packets from node A then it returns CTS packet to node A. This CTS packet also contains the expected length of the data transmission. If node A receives the CTS, it immediately transmits data to node B. The main idea of this approach is that any neighboring node that overhears an RTS packet will postpone its transmission until sometime after the associated CTS packet would have finished, and any node that overhead CTS packet, would postpone its transmission until the expected data transmission length that CTS packet includes. In a hidden-terminal problem as explained in Section 2.2.1, node C will not hear the RTS packet that sent by node A, but it would hear the CTS packet sent by node B. Therefore, node C will postpone its data transmission until node A's data transmission will finish as shown in Figure 3.6.

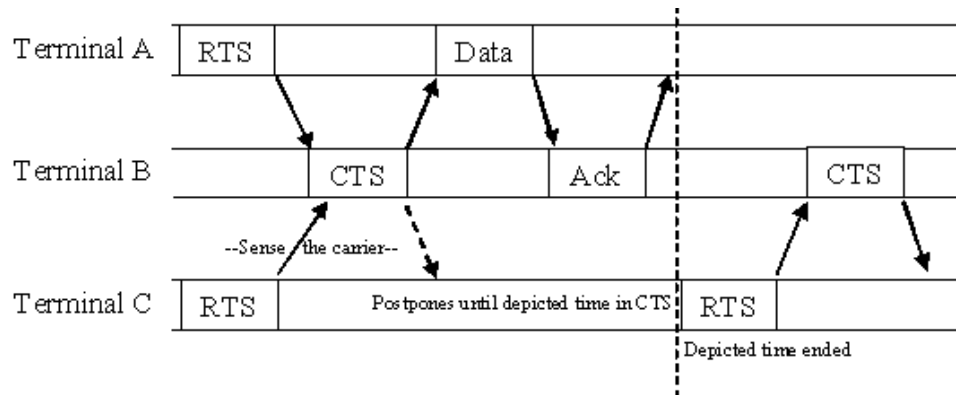

Figure 3.6: Solving the Hidden Terminal Problem using RTS-CTS Handshake

Similarly, in the exposed terminal situation as shown in Figure 2.2, node B has data to send to node A and node C has data to send to node D. As illustrated in Figure 3.7, Node C would hear the RTS packet sent by node B, but it wouldn't hear the CTS packet sent by node A. Therefore, C will consider the medium free for transmitting data to node D during node B's transmission.

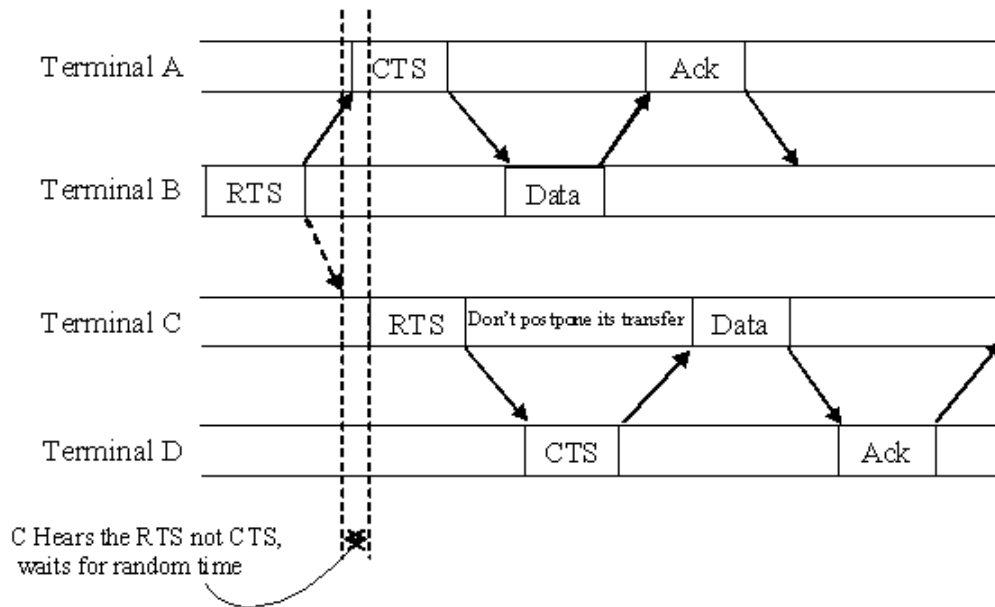

Figure 3.7: Solving the Exposed Terminal Problem using RTS-CTS Handshake

This RTS-CTS exchange reduces collision cases at the receiver side, but the collisions still may occur between two different RTS packets. When two different RTS packets collide, each sending node will wait for randomly chosen interval before sending RTS again. This situation continues until one of the nodes receive CTS packet to the intended RTS packet. This RTS-CTS packet exchange is more effective in increasing network throughput, because collisions between control packets (RTS/CTS) are less expensive than collisions between data packets. However the hidden terminal problem isn't always solved by RTS-CTS packet exchange. There may be collision cases such as different nodes send RTS and CTS packet simultaneously, an example scenario is written below. There are four nodes A, B, C and D as shown in Figure 3.8. Consider that the RTS packet is sent by node A to node B and node B replies with a CTS packet to node A. However, this CTS packet collides with the RTS packet sent by node D to node C. Node C has no knowledge of the future data transfer from node A to node B because it didn't get the CTS packet. Node D sends another RTS packet during data transferring from node A to node B, because it didn't get an answer from C.

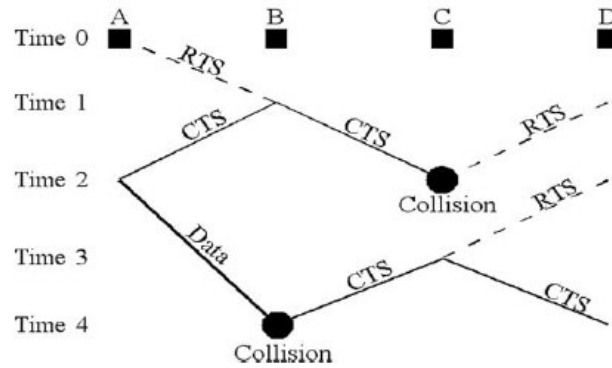

Figure 3.8: Failure of RTS-CTS Mechanism in Solving Hidden and Exposed Terminal Problems [30]

Because node C is unaware of data transmission from A to node B, it will reply with CTS packet to node D which results collision at node B. The performance of MACA degenerates to ALOHA [13] performance under high traffic load in the network, because of hidden terminals. Another disadvantage of MACA is that it doesn't provide acknowledgment of data transmission at the Data link layer. It provides it at the transport layer, which results with significant delays when a data transmission fails for any reason.

3.3 Code Division Multiple Access Based MAC Schemes

Applying CDMA-based MAC protocol on ad hoc networks has many problems, such as the CDMA Code assignment and inherent near-far problems because of the absence of centralized control (e. g., a base station or an access point). The CDMA code assignment protocols are used to assign distinct CDMA codes to different communicating pairs as discussed in Section 3.1.3.1. The nearby co-existing multiple transmissions cause the near-far problem of CDMA signal interference. To solve these problems the protocol must have a mechanism to allow the senders to negotiate on the transmission codes and power with intended receivers in the rendezvous, which is separated from where data exchange occurs, either in time or frequency domain.

3.3.1 Time Division Based Schemes

In the time-division based schemes, time axis is separated into two cycles which consists of negotiation periods and data exchange periods as depicted in the Figure 3.9.

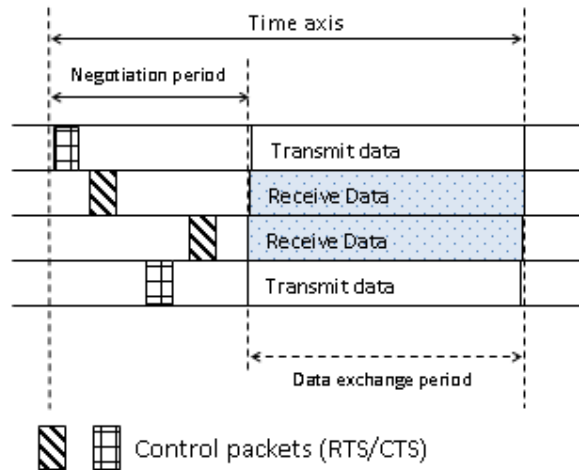

Figure 3.9: Illustration of Time Based MAC Scheme

During the negotiation phase, every node stops data transmission and adjusts its transceivers to the common channel with the same frequency and CDMA code. To send data to intended receiver, transmitting node must exchange some control packets with receiver to reserve the CDMA code for transmission (such as RTS-CTS). Hearing these control packets other nodes update their code assignment information. Figure 3.10 illustrates CDMA code reservation with control packets.

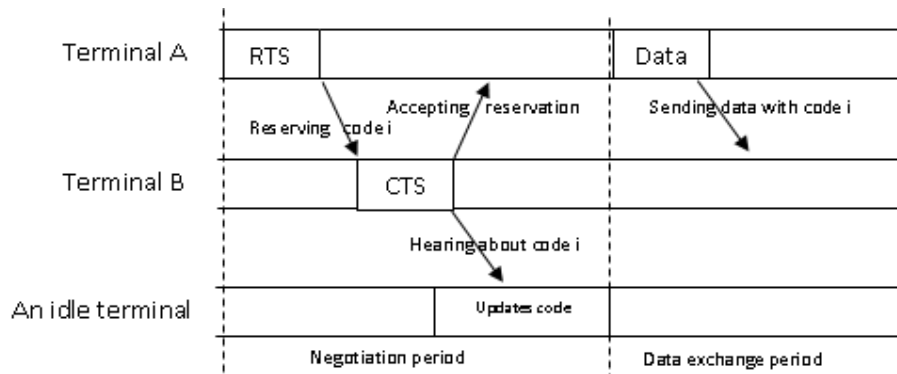

Figure 3.10: Reserving CDMA Code for Data Transferring

The main advantage of the time-division approach is that for each node only one transceiver is required. There are some papers which use time-division CDMA-based MAC protocol [34, 39].

3.3.2 Frequency Division Based Schemes

Besides from time-division based schemes, in the frequency-division based schemes for each node at least two sets of transceivers is required. In these schemes, available bandwidth is divided into control channel and data channel. One transceiver always monitors the control channel, while the other(s) is used for transmitting data in the data channel with distinct CDMA codes. Authors in [20, 40, 41] proposed frequency-division CDMA based MAC protocol where one transceiver listens to control channel and the other to data channel.

4. A TOKEN BASED CODE DIVISION MULTIPLE ACCESS MAC PROTOCOL

As stated in Section 3.1.4 token based MAC schemes are more suitable for providing real-time guarantees in Ad Hoc Networks. The main advantages of these schemes are that the packet delay is highly deterministic, the upper bound of the delay is predictable, collision problems are solved and also this type of systems support fairness. The determinism and predictability are two important properties of real time systems. So to overcome the problems stated before and provide necessary requirements for real time applications, a new token based CDMA MAC protocol is proposed in [20]. This protocol uses frequency-division based approach, in which at each node there are two sets of transceivers. Available bandwidth is separated into two channels; token and data channels. One transceiver is used to transmit the token in the virtual ring and the other is used for data transmission. In this thesis we propose a MAC protocol, which uses the token-based CDMA approach and the time-division based schemes to provide real time guarantee. The proposed MAC scheme requires only one transceiver per node, which reduces the hardware costs for large scale wireless networks. Our protocol can work with or without Multiple User Detection (MUD) hardware as described in the next sections. MUD hardware provides the receiver station to receive multiple transmissions with different CDMA codes simultaneously. To understand how the process is going on in the time-division based schemes, it will be helpful to review how Power Saving Mechanism (PSM) works in IEEE 802.11.

4.1 IEEE 802.11 Power Saving Mechanism

It is known that node consumes much less energy in the sleep mode than in the idle mode. Therefore, to save energy node must enter the sleep mode if there is no communication need. In the IEEE 802.11, time axis is consisting of beacon intervals and each beacon interval is divided into two phases. These phases are Ad Hoc Traffic Indication Messages (ATIM) window and data window which is shown in Figure

4.1. Each node in the network is synchronized by periodic beacon transmission. So, all nodes in the network enter and leave each beacon interval at the same time.

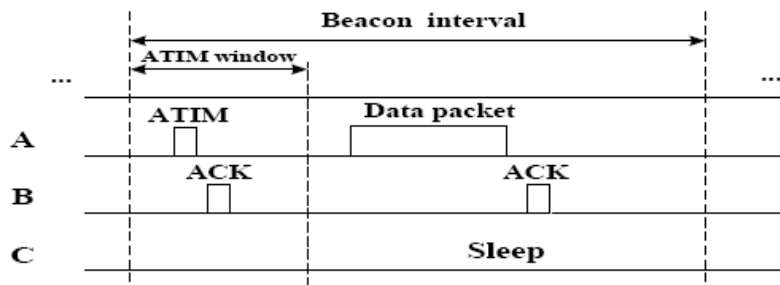

Figure 4.1: IEEE 802.11 Power Saving Mode

Each beacon interval begins with the ATIM windows in which each node in the network is in non-sleep mode. Consider that Node A has data to send to node B, before sending data, node A sends an ATIM window to node B during ATIM window interval. When node B receives this packet it replies with ACK packet to node A. So both nodes A and B stay in non-sleep mode during the entire beacon interval. If node, such as node C, has not sent or received any ATIM frames during ATIM window interval, it enters the sleep mode until the next beacon interval. One important issue in IEEE 802.11 is how to design the size of ATIM window. A large size of ATIM window leads to a long delay and low throughput, while a small size of ATIM window may result that the nodes don't have enough time to finish the exchange of ATIM/ACK frames. An effective solution is to adjust the size of ATIM window according to the number of active nodes in the network.

4.2 Topology of the Network

The topology of the network has the same characteristic of an ad hoc network. The network consists of N stations with M CDMA codes ($M < N$). It has distributed and de-centralized modeling. Time axis is divided into two cycles, like in IEEE 802.11, which consists of Token Traveling Periods (TTP) and data transfer periods as shown in Figure 4.2. During TTP duration, every node stops data transmission and adjusts its transceiver to the common channel with the same frequency and CDMA code. The sender station reserves CDMA code for data transferring in TTP duration, this reserved CDMA code will be used to send packet in data transferring period. All

nodes in the network dynamically estimate the length of TTP based on the active number of nodes in the network.

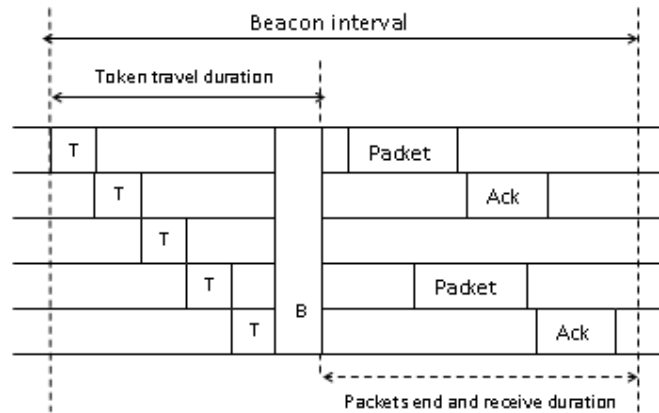

Figure 4.2: Proposed Token Based CDMA MAC Protocol

The network uses virtual ring topology as its backbone structure. To distribute M CDMA codes in the network, the token is created by a hop leader and is travelled on the virtual ring during the TTP duration as shown in Figure 4.3. After token travels all stations, hop leader broadcasts the token's last position to all stations in the network (if the MUD hardware is used then there is no need for broadcasting). It is described in the section 4.2.2 why there is a need for broadcasting the token. The data transfer begins in the data period as shown in Figure 4.2.

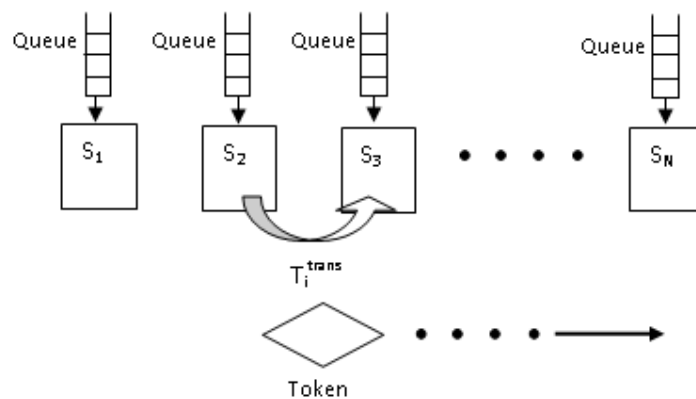

Figure 4.3: Illustration of the Token Travelling on the Virtual Ring

4.2.1 Station and Token Structure

In order to know where the token should be passed, stations have an updated STATION-LIST (as shown in table 4.1) table of their neighbors.

Table 4.1: Table of the Station Address

Token Transmission Order	Station Address
1	101010
2	001110
3	110010
4	111110

This station list is broadcasted by hop leader at the beginning of each beacon interval. Unlike other CDMA code distribution algorithms, in which control packets are used to distribute CDMA codes in this protocol a token is used to distribute CDMA codes in the network. The token consists of a hop-leader address, a source address, a destination address, the number of codes available (NOC) and other parameters as shown in Table 4.2.

Table 4.2: The Structure of the Token

P M	Hop Leader ID	Source ID	Destination ID	NOC	C-List	DB	EOT
--------	------------------	--------------	-------------------	-----	--------	----	-----

The sizes of these fields can be easily adjusted depending on the scale of the network.

- **PM:** Preamble is the Physical Layer (PHY) header used to perform synchronization with destination station using pilot, synchronization and paging channels in CDMA transmission. To conform to the IEEE 802.11 standard, the proposed protocol uses the same standardized PHY header of 128 bits.
- **Hop Leader ID:** The address of the station that created the token and initialized the network.
- **Source ID:** The address of the station that passed the token (predecessor's address).
- **Destination ID:** The address of the station that hold the token (successor's address).
- **NOC (Number of Codes Available):** This parameter is used to limit the number of simultaneous transmissions in the network.

- C_LIST (Channel-List): This parameter is used to monitor the status of the receiver's channel in the network. There is no need for this field when the MUD hardware is used as described later in Section 4.2.2
- DB (Duplicate Bit): This parameter is used by the token protection scheme to inform the receiver station that the generated token is for a re- transmission.
- EOT (End of Token): This parameter is used to indicate that the token has been received by the receiver station.

4.2.2 Channel Access Control

As shown in Figure 4.2, the time axis is divided into beacon intervals, each beacon interval consists of TTP and data period. At the beginning of each beacon interval a token is generated by the hop leader. In TTP duration, the created token travels all stations of the network by predetermined order. This predetermined order of nodes in the network is created by hop leader at each beacon interval and is broadcasted to all nodes in the network, STATION_LIST, at the beginning of TTP duration. In Section 4.2.3, it is described why the STATION_LIST (predetermined order of nodes) is created and broadcasted to all nodes in the network at each beacon interval. The NOC parameter of the token is used to control the amount of traffic flow in the network. If the station has data packets to send, it waits for the token to arrive. After getting the token, the station firstly checks the parameter NOC, if the NOC parameter is bigger than zero, then the station checks the receiver station's channel status from C_LIST, which is downloaded from the token. If the receiver is free to receive a packet then the NOC parameter is decreased by one and the intended receiver's field in C_LIST is set (showing that this receiver is reserved for data receiving) to the number of free CDMA code as shown in Figure 4.5. After this process, the token is transmitted to the next neighbor station, indicated in the station list. If the NOC parameter is zero or the intended receiver is not free (receiver will get packets from other transmitter) or the station doesn't have any packet to send, then the token is transmitted immediately to the next station which is shown in station list. After token travels all nodes in the network, it will be broadcasted to all nodes by the hop leader. The reason of this broadcasting is that the receiver stations must tune their transceivers to the code which is indicated in the token by the sender station to receive packet in a correct order.

To clearly understand the reason of broadcasting, the sample scenario of the network with virtual ring topology is given in Figure 4.4.

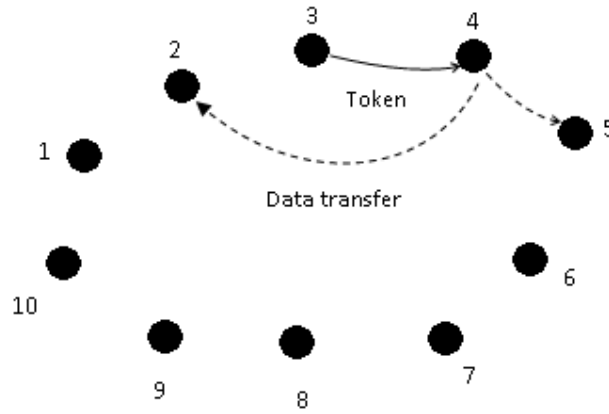

Figure 4.4: Illustration of Broadcasting Requirement

In this network, node 4 has a packet to send to node 2. When the token is received by node 4, and if the node 2 is free to receive a packet, it will change node 2's field in the C_LIST field of the token by the CDMA code number, saying that the node 2 have to receive packets with this CDMA code. But unfortunately the token travels nodes by order (1, 2, ..., 10) and after the token travels all nodes, at the end of TTP period, the node 2 will not know whether it has to receive packets or not, and if it has, then with which CDMA code it must receive. Therefore, there is a need to broadcast the last token's situation to all nodes in the network predicting which CMDA codes will be used by which receivers. A token cycle (T_c) is the time for the token to travel all stations in the network and it is calculated by Equation 4.1.

$$T_c = \sum_{i=1}^N T_i^{trans} \quad (4.1)$$

Here, T_i^{trans} is the token forward time, time taken for a token to travel from station i to its successor station $i+1$. So, the TTP duration will be like follows

$$T_T = \sum_{i=1}^N T_i^{trans} + T_{N+1}^{trans} = \sum_{i=1}^{N+1} T_i^{trans} \quad (4.2)$$

T_{N+1}^{trans} time taken to broadcast the token to all stations in the network. For the transmission and reception of data packets, the sender station inserts destination station's address into the data packet before transmission. An algorithm is needed to prevent packet collisions which caused by multiple simultaneous transmissions to the same receiver station, and these collisions are prevented by using C_LIST field of the token. In this list, the data is stored about which stations are free to receive data, or which stations are reserved for data receiving with written CDMA code in this station's field, as shown in Figure 4.5.

The zero means that this receiver is free to receive the data. k ($1 \dots M$) means that this station is reserved for data receiving and will use CDMA code k ($1 \dots M$) to receive the data.

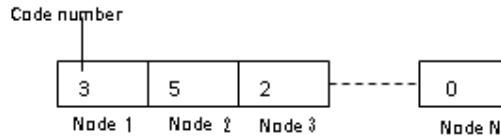

Figure 4.5: Channel List

If there is MUD hardware in the system, then the process will work as follows:

After station gets the token, it checks NOC parameter, if the NOC parameter is bigger than zero then the data transmission is permitted. The station decreases the NOC parameter by one and transmits the token to the next neighbor station in the Station List. There is no need to check if the receiver is free to receive data or not, due to MUD hardware the receiver able to receive multiple transmissions with different CDMA codes simultaneously. The receiver station constantly monitors code channels to detect any incoming data traffic destined for it. So, there is no need for broadcasting token's last situation to all stations in the network. In this scheme TTP duration will be calculated as given in Equation 4.3.

$$T_T^{mud} = \sum_{i=1}^N T_i^{trans} \quad (4.3)$$

4.2.3 Channel Access Order

When the number of CDMA codes in the network is smaller than the number of stations, then the same channel access order can't be used in each beacon interval. The reason is that nodes which are at the beginning of the station list, will access the channel much more time than the stations which are at the end of the station list. Some mechanism is needed for changing channel access order of stations so that each station will receive the same fairness in the network. After each beacon interval the channel access order of stations is changed by some rule, in which it is guaranteed that each station in the network will get access to the channel during each $\left\lceil \frac{N}{M} \right\rceil$ beacon intervals. So it can be guaranteed that each station can access channel waiting not bigger than the time which can be calculated by equations as shown below.

Consider that there is one CDMA code in the network, and then the maximum waiting time for the station to access the channel can be calculated by Equation 4.4.

$$T_{\max} = N * (T_{sl} + T_T) + (N - 1) * T_p \quad (4.4)$$

N – Number of nodes

T_T – Token travelling period duration

T_p – Packet send and receive duration (data transfer period)

T_{sl} – Time taken to broadcast STATION_LIST to all stations in the network

Here T_T is calculated by Equation 4.2.

If there is MUD hardware in the system then the T_T parameter will be replaced by T_T^{mud} parameter.

To clearly understand parameters in Equation 4.4, proposed algorithm is described in Figure 4.6.

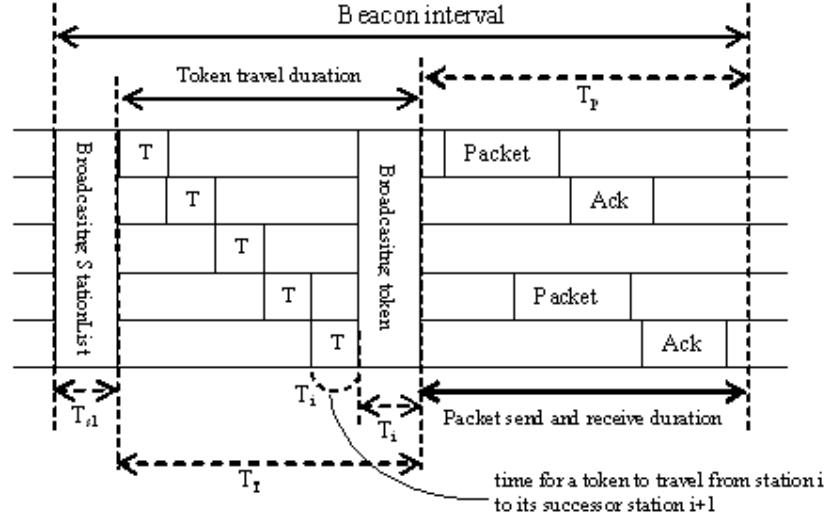

Figure 4.6: Illustration of Detailed Working of Proposed MAC Scheme

If there are two CDMA codes in the network, then the station will access the channel waiting time not bigger than the time which can be calculated by Equation 4.5.

$$T_{\max} = \left\lceil \frac{N}{2} \right\rceil * (T_{sl} + T_T) + \left(\left\lceil \frac{N}{2} \right\rceil - 1 \right) * T_p \quad (4.5)$$

So if there are M CDMA codes in the network, then the maximum waiting time for the station to access the channel is calculated by Equation 4.6

$$T_{\max} = \left\lceil \frac{N}{M} \right\rceil * (T_{sl} + T_T) + \left(\left\lceil \frac{N}{M} \right\rceil - 1 \right) * T_p \quad (4.6)$$

For example if the number of CDMA codes in the network equals to the number of stations in the network ($M=N$) $\left\lceil \frac{N}{M} \right\rceil = \left\lceil \frac{N}{N} \right\rceil = 1$, then the maximum waiting time is

$$T_{\max} = 1 * (T_{sl} + T_T) + (1-1) * T_p = T_{sl} + T_T \quad (4.7)$$

If number of CDMA codes in the network is bigger than the number of stations in the network ($M>N$), the maximum waiting time is the same as stated before.

4.3 Dynamic Topology

The Finite State Machine (FSM) for proposed MAC scheme is presented in Figure 4.7. The states are: Initialization State (IS), Join State (JS), Sense State (SS), Token transmit State (TS), Packet transmit State (PS) and Lost State (LS). The proposed MAC scheme is operated in the dynamic mobile wireless network (the mobility of stations has been considered), therefore the topology of the network changes frequently. JS and LS states are for stations which want to join or leave the network. The SS is for detecting the token transmission. After getting the token, if there is a packet to send then the CDMA code is reserved and station changes its state to TS for transmitting token to the next station. After transmitting the token, station returns to SS again. SS and TS states take over in TTP duration. After TTP, stations enter PS state for servicing the packets. The proposed protocol starts in the IS.

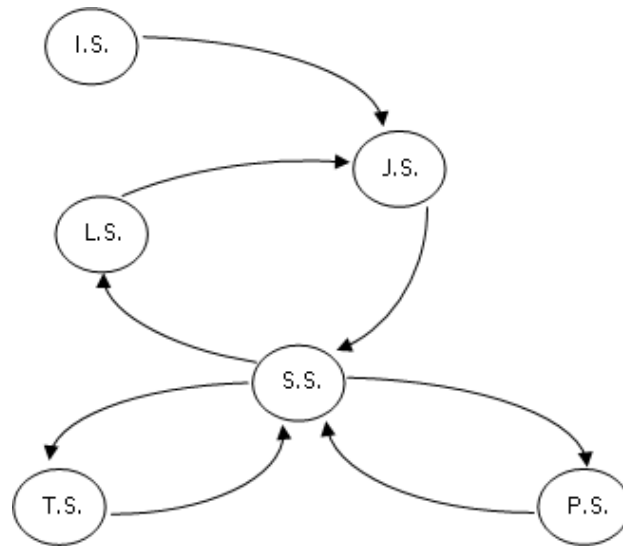

Figure 4.7: Finite State Machine

4.3.1 Station Entering Routine

Joining of new stations to the network is considered in this section. To join the network a new station must wait for UPDATE_NETWORK beacon cycles. When the network is initialized the value of UPDATE_NETWORK is predefined and stored in hop leader. Since the UPDATE_NETWORK is a variable, it is possible to dynamically adjust it according to the network scale (number of stations in the network).

To record the number of beacon intervals that have passed, a hop leader is equipped with a Beacon-Interval-Counter (BIC). Once the value of UPDATE_NETWORK is reached, the hop leader activates the insertion algorithm. Hop leader first sets its BIC to zero and broadcasts a NODE_WELCOME message using the token code channel. NODE_WELCOME message broadcasting takes place at the beginning of the beacon interval before TTP duration as shown in Figure 4.8. After broadcasting, hop leader activates the REQUEST_TIMER for the contending stations to respond.

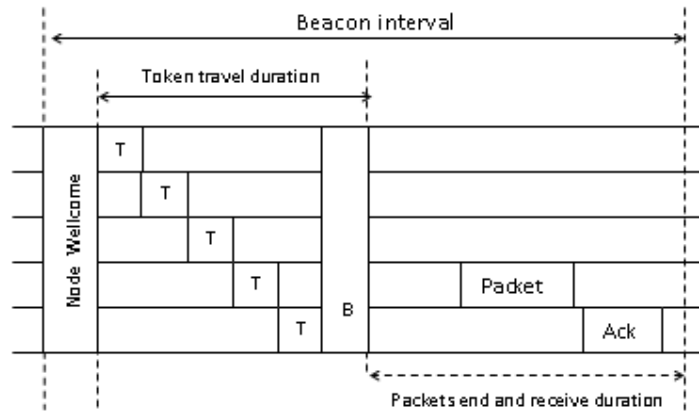

Figure 4.8: Illustration of Node Welcome Message

If REQUEST_TIMER has expired and no responses were received, hop leader simply creates the token and starts TTP period.

To join the network stations must constantly monitor the token code channel. When the NODE_WELCOME message is detected the insertion process starts. If two or more stations are waiting to join the network, packet collisions may occur. To prevent these collisions intending stations use a timer mechanism in the token code channel. After receiving a NODE_WELCOME message, intending stations start a CONTENT_TIMER timer. This timer is proportional to station address and has an upper bound of REQUEST_TIMER. The station, whose timer expires, first gets the permission to join the network by transmitting its address to the hop leader. All other intending stations will reject the contention until the next NODE_WELCOME message because of detecting activity in the token code channel before their time expired. Hop leader inserts the new station's address to the STATION-LIST and broadcasts the new STATION-LIST to all stations in the network. After new station joined the network, hop leader creates the token, and inserts new station address to

the C_LIST field. Hop leader starts TTP duration by sending the token to the next station.

Including the time which is taken for broadcasting NODE_WELCOME message and inserting a new joined station to the network, then the maximum waiting time for the station to access the channel is calculated not by Equation 4.6 but by the next equation

$$T_{\max} = \left\lceil \frac{N}{M} \right\rceil * (T_{sl} + T_T) + \left(\left\lceil \frac{N}{M} \right\rceil - 1 \right) * T_p + \left[\frac{\left\lceil \frac{N}{M} \right\rceil + 1}{UPDATE_NETWOK} \right] T_{NW} \quad (4.8)$$

T_{NW} – time taken for broadcasting NODE_WELCOME message and inserting a new joined station to the network

As stated before, if MUD hardware will be used then T_T parameter will be replaced by T_T^{mud} parameter in Equation 4.8.

4.3.2 Station Lost Routine

There are two possible states in which a station will be detached from the network: these are leave on demand and sudden death states. Both of these scenarios are considered in this MAC protocol.

4.3.2.1 Leave on Demand

If station i wants to leave the network, it waits for TTP duration. When TTP duration starts after getting the token, station i changes the address of the sender (source ID field) to $i-1$ instead of its address in the token. Its successor station $i+1$ will know that station i wants to leave the network, by looking to the source ID field in the token which contains the address of station $i-1$. Station $i+1$ will change station i 's value in the C_LIST field of the token by -1 which means that this station has left the network. So all stations in the network will be aware of that the station i left the network and will not send any packets to this node. But with MUD hardware the system will not work like explained, because the token doesn't have a C_LIST field. There is a need for an extra parameter in the token to declare that some stations have

left the network. So if MUD hardware is used in the system then the token structure will be like the structure shown in Table 4.3.

Table 4.3: Token Structure in the System which has MUD Hardware

P M	Hop Leader ID	Source ID	Destination ID	NOC	NA-List	DB	EOT
--------	------------------	--------------	-------------------	-----	---------	----	-----

- NA-List (Node Activity List): This field displays activity status of the stations in the network. If the station is in the network then the bit apportionment for this station is set to 1, but if the station has left the network then the bit apportionment for this station is set to 0.

Finally with NA-List parameter of the token all stations in the network will be aware of that if the station is in the network or not.

4.3.2.1 Sudden Death

If station i leaves the network suddenly without any prediction, its predecessor station $i-1$ will understand its absence when transmitting the token. After discovering station i 's leave, node $i-1$ will change the (Destination ID field) receiver address by the address of station $i+1$ and will change the status bit of the station i in C_LIST field in the token. After this process station $i-1$ will transfer the token to station $i+1$. So, all stations in the network will be aware of station i 's absence from C_LIST field of the token.

5. SIMULATION ENVIRONMENT AND RESULTS

5.1 System Architecture

As stated before, in order to provide real-time communication capabilities, suitable protocols must be designed and implemented. In the proposed system, the token based CDMA protocol is used as the MAC sub layer protocol.

The network is a token based consisting of N stations. A special frame called token is circulating around the virtual ring during TTP duration. This token gives the permission to the stations to reserve free CDMA codes for the packet transferring in the data period duration. The token may travel around the virtual ring in the order $1, 2, \dots, N$ which is actually the case for Fiber Distributed Data Interface (FDDI). But in the wireless medium since there are no physical restrictions, the token may circulate in any order. Consider the network consisting 10 stations as given in Figure 4.4 and suppose that they are all in the transmission range of each other. Considering the wireless links in the given example, this network is a fully connected mesh where any station can reach any other station. In this network the token may travel in the linear order such as $1, 2, 3, 4, \dots, 10; 1, \dots$. But since there are no physical restrictions in the wireless medium, the token may travel in any order like $1, 2, 3, 4, \dots, 10; 6, 5, 7, \dots$. This arbitrary token circulating order can be determined by giving some stations high priority, some stations low priority and etc. When the MUD hardware is used this order can be determined by the function of number of CDMA codes in the network for giving every station in the network same fairness. For example, if there are 5 CDMA codes in the network then the token circulating order can be determined like this $1, 2, 3, 4, 5, \dots, 10; 6, 7, 8, 9, 10, 1, \dots, 5$; for giving each station same fairness. By using such token passing mechanisms other than the conventional approach (linear token passing) the network utilization may be increased as described before in Section 4.2.3.

The token based protocols are able to provide hard real time communication capabilities because of its special timing properties. The upper bound for delay in

these systems is known and hence the system becomes predictable which is the primary requirement for real time systems. These properties of token based MAC schemes make it suitable for real time systems.

The proposed MAC scheme is studied with only one message class namely the synchronous messages. Asynchronous messages are non periodic as opposed to the synchronous messages. Also this type of messages does not have real time constraints like synchronous messages.

Briefly, at the initialization phase of the network, the hop leader selects the data period duration in which stations will send and receive packets to each other. This data period duration is calculated considering all network load by the hop leader. The average data transfer duration (data period duration) is calculated by considering to be transferred data sizes in each station. This value must be properly selected to provide real time guarantees to the stations in the network.

If the data period duration is negotiated as a smaller value, then the token travels through the virtual ring more frequently which causes the overheads to become more dominant.

If the data period duration is negotiated as a larger value, then the token travels through the virtual ring less frequently which causes some packets miss their deadlines.

As it is seen determining data period duration is crucial to provide real time guarantees.

5.2 The Network and Message Model

The messages generated in the network are classified as synchronous messages. There are N streams of synchronous messages at certain moment

$$S = \{S_1, S_2, \dots, S_N\} \tag{5.1}$$

where S_i originates at node i . Also each synchronous message stream S_i can be characterized as

$$S_i = \{C_i, P_i, D_i\} \quad (5.2)$$

Where

C_i – is the size of packet in the stream.

P_i – is the inter arrival period between packets in the stream.

D_i – is the relative deadline of the packet in the stream, which is the maximum amount of time between a packet arrival time and packet transmission time.

5.3 Theoretical Background

First of all, the size of the token must be calculated to check whether the theoretical results conform to the practical results. The token consists of PM, Hop Leader ID, Source ID, Destination ID, NOC and C_LIST fields as shown in Table 4.2. So the token's size can be calculated by the next equation (by bits) :

$$Size_{token} = S_{PM} + \lceil \log_2 N \rceil * 3 + \lceil \log_2 M \rceil + \lceil \log_2 M \rceil * N \quad (5.3)$$

S_{PM} – The size of PM header (128 bit)

N – The number of nodes in the network

M – The number of CDMA codes in the network

$\lceil \log_2 N \rceil * 3$ – the size of bits for Hop Leader ID, Destination ID, Source ID

$\lceil \log_2 M \rceil$ – the size of bits for NOC parameter

$\lceil \log_2 M \rceil * N$ – the size of bits for C_LIST field

The size of the STATION_LIST can be calculated by Equation 5.4.

$$Size_{SL} = \lceil \log_2 N \rceil * N \quad (5.4)$$

T_{trans} – time taken to transmit the token from station i to its successor station $i+1$,

T_{SL} – time taken to broadcast STATION_LIST, can be calculated as in Equation 5.5 and Equation 5.6.

$$T_{SL} = \frac{Size_{SL}}{C_s} = \frac{\lceil \log_2 N \rceil * N}{C_s} \quad (5.5)$$

$$T_{trans} = \frac{Size_{token}}{C_s} = \frac{S_{PM} + \lceil \log_2 N \rceil * 3 + \lceil \log_2 M \rceil * (N + 1)}{C_s} \quad (5.6)$$

So the maximum waiting time for the station to access the channel can be calculated by Equation 5.7.

$$T_{max} = \left\lceil \frac{N}{M} \right\rceil * \left(\frac{\lceil \log_2 N \rceil * N}{C_s} + (N + 1) \frac{S_{PM} + \lceil \log_2 N \rceil * 3 + \lceil \log_2 M \rceil * (N + 1)}{C_s} \right) + \left(\left\lceil \frac{N}{M} \right\rceil - 1 \right) * T_p + \left[\frac{\left\lceil \frac{N}{M} \right\rceil + 1}{UPDATE_NETWORK} \right] * T_{NW} \quad (5.7)$$

C_s – channel speed (by bps)

T_p – packet send and receive duration, data period duration

T_{NW} – time taken for broadcasting NODE_WELCOME message and inserting a new joined station to the network

UPDATE_NETWORK – predetermined value, when BIC (beacon interval counter) reaches to this value the Insertion algorithm for new nodes begins.

This T_{max} is the maximum waiting time for the station to access the medium, but not the maximum packet delay, in the systems which do not have MUD hardware. In these systems maximum packet delay also depends on the packet's destination address due to the receiver station cannot receive multiple packet transmissions simultaneously. So T_{max} in these systems is the maximum waiting time for a station to access the channel.

But in systems at which each station has the MUD hardware, this T_{max} is the maximum packet delay. The packet delay does not depend on destination address in these systems. The packet delay is calculated as below.

Packet delay = (leaving time from queue) – (arrival time at the first place in queue)

The packet delay is defined as the time period from time when a packet arrives at the front of queue of a station to the time it is successfully transmitted to the intended receiving station. The packet transmission time is not concluded, i.e. , the packet delay is the time delay determined by the efficiency of each MAC algorithm.

5.4 Development Environment

The work proposed in this thesis was implemented using the Microsoft Visual Studio 2005 software development environment using the C# programming language. The simulations were run on a PC with “Intel Core Duo” 2.0 GHz CPU (Central Processing Unit). The system had 1 GB of RAM (Random Access Memory).

5.5 Performance Analysis

In this section, the performances of the proposed MAC scheme and the MAC scheme which proposed in [20] are compared for various metrics. From now on, the MAC scheme in [20] will be called as two transceiver based MAC scheme and the proposed MAC scheme in this thesis will be called as one transceiver based MAC scheme. It is assumed that in each system every station has MUD hardware. The metrics that are used for performance analysis are throughput and packet delay.

As described in Section 4, the two transceiver based protocol is a hybrid Token CDMA MAC protocol which uses frequency division based scheme for selecting CDMA codes. In this MAC scheme, it is assumed that each station in the network has two transceivers, one is used for data transmission and the other one is used for token transmission. The MUD hardware is also incorporated in the system, which makes possible for stations to receive multiple transmissions simultaneously. The token structure in this system is depicted in the next table

Table 5.1: The Structure of the Token in Two Trans Based MAC Scheme

P M	Hop Leader ID	Source ID	Destination ID	NOC	NA-List	C-List	DB	EOT
--------	------------------	--------------	-------------------	-----	---------	--------	----	-----

The size of the token in two transceiver based scheme can be calculated as follows:

$$Size_{token} = S_{PM} + \lceil \log_2 N \rceil * 3 + \lceil \log_2 M \rceil + M * N + N \quad (5.8)$$

S_{PM} – The size of PM header (128 bit)

N – The number of nodes in the network

M – The number of CDMA codes in the network

$\lceil \log_2 N \rceil * 3$ – the size of bits for Hop Leader ID, Destination ID, Source ID

$\lceil \log_2 M \rceil$ – the size of bits for NOC

$M * N$ – the size of bits for C_LIST field

N – The size of bits for Active Node List field

The token structure for one transceiver based MAC scheme which has the MUD hardware is showed in Table 4.3. So, the size of the token is as follows

$$Size_{token} = S_{PM} + \lceil \log_2 N \rceil * 3 + \lceil \log_2 M \rceil + N \quad (5.9)$$

The difference between these tokens' structure is the C_LIST field. The token size is smaller in one transceiver based MAC scheme than in two transceiver based MAC scheme.

System parameters for performance analysis of these MAC schemes are given in Table 5.2.

Table 5.2: System Parameters (Increasing Code Numbers)

Symbol	Parameter
Number of nodes	30
PHY header	128
Channel bit rate	54 Mbps
Number of CDMA codes	2,3,5,6,10,15

The size of each packet in stream is 5KB (C_i), the interarrival period between packets in the stream is 1000 micro seconds (P_i), the relative deadline of the packet in the stream is considered as unlimited (D_i) and also in each stream there are 100 packets.

The theoretical maximum packet delays for one transceiver based MAC scheme can be calculated by Equation 5.10.

$$T_{\max} = \left\lceil \frac{N}{M} \right\rceil * (T_{sl} + T_T) + \left(\left\lceil \frac{N}{M} \right\rceil - 1 \right) * T_p \quad (5.10)$$

Here,

$$T_T = \sum_{i=1}^N T_i = N * \left(\frac{S_{PM} + \lceil \log_2 N \rceil * 3 + \lceil \log_2 M \rceil + N}{C_s} \right) \quad (5.11)$$

So the maximum packet delay is given in Equation 5.12.

$$T_{\max} = \left\lceil \frac{N}{M} \right\rceil * \left[\frac{\lceil \log_2 N \rceil * N}{C_s} + N * \left(\frac{S_{PM} + \lceil \log_2 N \rceil * 3 + \lceil \log_2 M \rceil + N}{C_s} \right) \right] + \left(\left\lceil \frac{N}{M} \right\rceil - 1 \right) * T_p \quad (5.12)$$

T_p is calculated considering the packet sizes in the network, in this system there is only one type of packets which size is 5KB, so it can be calculated as follows

$$T_p = \frac{5000 * 8}{54} + \mathbf{1}(\text{one micro second for extra}) = \mathbf{741 \text{ microsecond}}$$

Scenario 1: (Number of nodes) $N=30$, (Number of CDMA codes) $M = 2$. Then the theoretically maximum packet delay for this scenario will be as shown below

$$T_{\max} = \left\lceil \frac{30}{2} \right\rceil * \left[\frac{\lceil \log_2 30 \rceil * 30}{54} + 30 * \left(\frac{128 + \lceil \log_2 30 \rceil * 3 + \lceil \log_2 2 \rceil + 30}{54} \right) \right] + \left(\left\lceil \frac{30}{2} \right\rceil - 1 \right) * 741 = \dots = \mathbf{11864,7 \text{ micro seconds}}$$

Scenario 2: $N=30$, $M = 3$. Then from Equation 5.12 the maximum packet delay will be $T_{\max} = 7668,8$ micro seconds

Scenario 3: $N=30$, $M = 10$. For this scenario the maximum packet delay is $T_{\max} = 1785$ micro seconds

Scenario 4: $N=30$, $M = 15$. Then the theoretically maximum packet delay will be like this $T_{\max} = 943,36$ micro seconds.

Increasing M after this value will not change T_{max} , if number of CDMA codes in the system (M) will be equal to the number of stations in the network (N) then maximum packet delay will be $T_{max} = T_{SL} + T_T$. In Any value between 15 and 30 ($15 \leq M < 30$) theoretically maximum packet delay will be as in Scenario 4.

The practical results for one transceiver based MAC scheme are depicted in Table5.3.

Table 5.3: Practical Results for given Parameters in One Trans Based MAC Scheme

Code numbers	Maximum Packet delay(ms)	Average Packet delay(ms)	Variance	Total duration for trans.(s)	Token size (Byte)
2	11.864	11.805	0.688	1.26	21.75
3	7.668	7.630	0.447	0.84	21.875
5	4.308	4.287	0.253	0.504	22
6	3.466	3.450	0.205	0.42	22
10	1.785	1.777	0.108	0.252	22.125
15	0.943	0.939	0.059	0.168	22.125

Total duration – is the time taken by the protocol to transmit all the packets that have entered the queue. Total packet size in the system is 15 MB.

Token size – is the size of the token for each scenario (number of nodes, number of codes and etc.). Token size increases with increasing number of CDMA codes.

As shown in Table 5.3, the practical results conform to the theoretical results which are calculated by given equations.

Practical results for two transceiver based MAC scheme are like this:

Table 5.4: Practical Results for given Parameters in Two Trans Based MAC Scheme

Code numbers	Maximum Packet delay(ms)	Average Packet delay(ms)	Variance	Total duration for trans.(s)	Token size (Byte)
2	16.795	11.976	1.214	1.292	29.25
3	11.484	7.805	0.811	0.8667	33.125
5	7.413	4.505	0.596	0.54029	40.75
6	6.376	3.681	0.593	0.45639	44.5
10	4.027	2.038	0.395	0.28335	59.625
15	2.742	1.208	0.279	0.20098	78.375

The graphical interpretation of results can be shown as below:

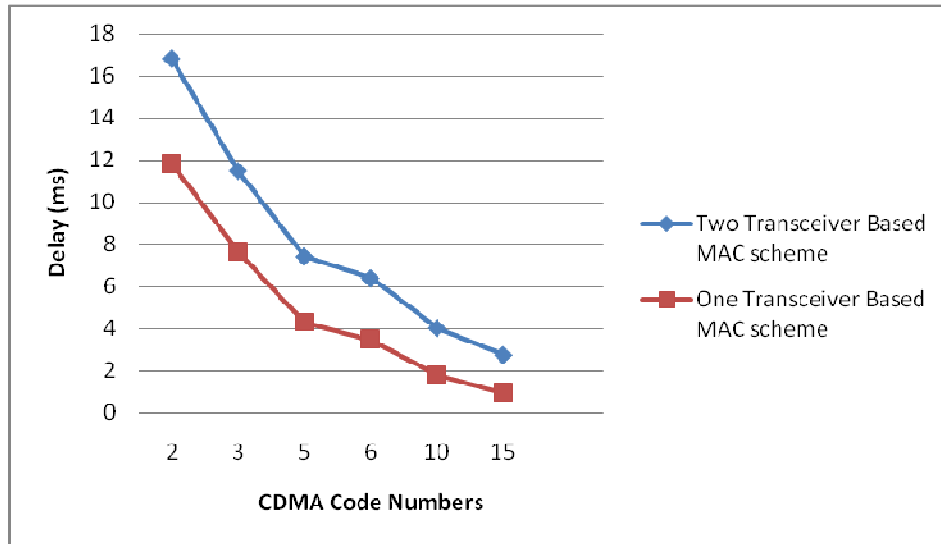

Figure 5.1: Maximum Packet Delay (Increasing Code Numbers)

As shown in Figure 5.1 one transceiver based MAC scheme has better performance than two transceiver based MAC scheme. The maximum packet delay in one transceiver based MAC scheme does not depend on packets' destination address unlike two transceiver based MAC scheme.

Figure 5.2 shows the average packet delays in each system. As shown in this figure, both systems have nearly the same average packet delays, but the variances are very different as shown in Table 5.3 and Table 5.4. One transceiver based MAC scheme has smaller variances than other scheme, which gives better predictable average packet delays.

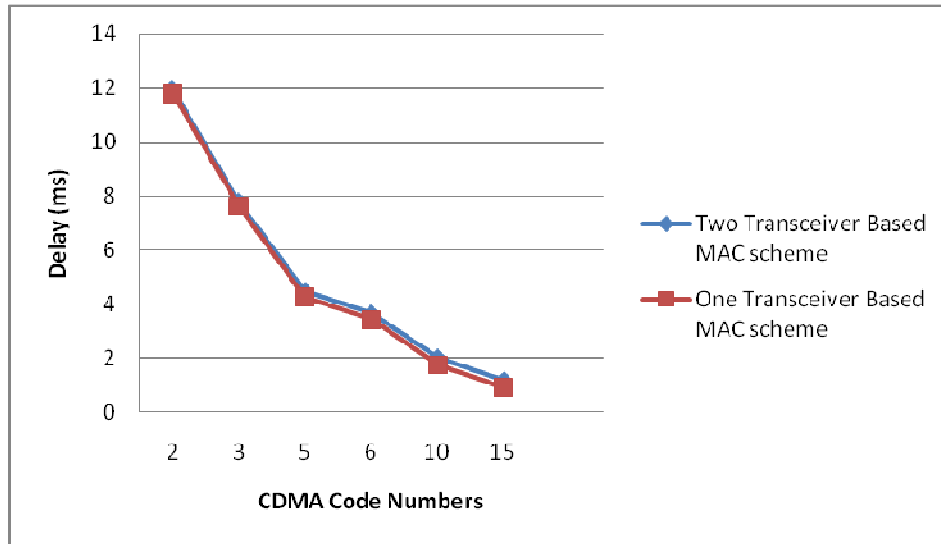

Figure 5.2: Average Packet Delay (Increasing Code Numbers)

Additionally the time duration for transmitting the all given packets in each system is compared in Figure 5.3.

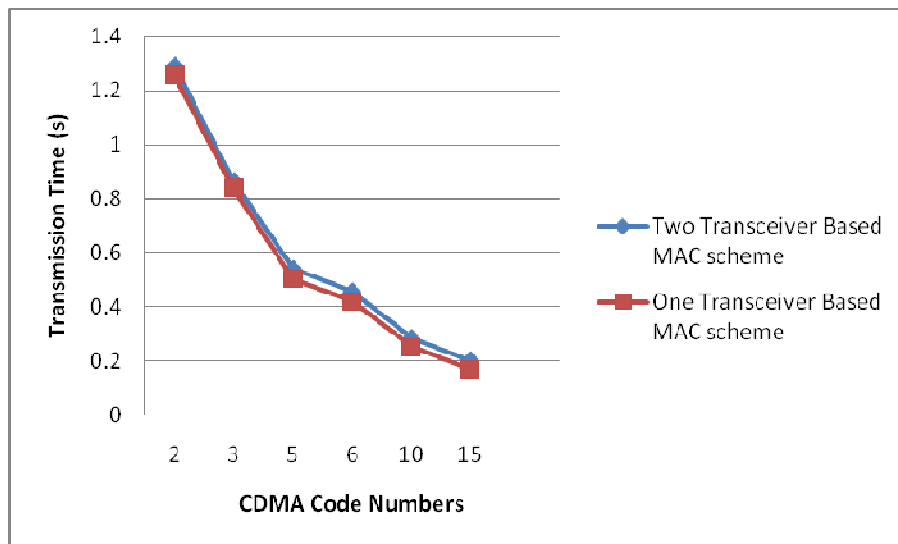

Figure 5.3: Time Duration for Transmitting All Packets (Increasing Code Numbers)

As shown from this figure, needed time duration for transmitting all packets in the network is smaller in one transceiver based MAC scheme than two transceiver based MAC scheme.

There are some reasons that one transceiver based MAC scheme is more effective in decreasing the packet delay and increasing the channel utilization than two transceiver based MAC scheme.

First of all, one of the main reasons is that the token size in one transceiver based MAC scheme is smaller than the token size in two transceiver based MAC scheme. The structures of the both tokens are depicted in Table 4.3 and Table 5.1.

Each parameter of the token is described in the section 4.2.1. The difference between these two tokens' structures is the C_LIST parameter which is shown in Figure 5.4. There is no need for C_LIST parameter in one transceiver based MAC scheme. The C_LIST is structured to depict the status of the code channels that are being used in the receiving station. Once the token has visited the station and there is a packet to transfer, the station then looks up the NOC parameter in the token to observe whether there is an available CDMA code.

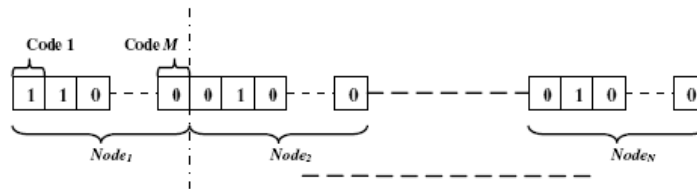

Figure 5.4: Structure of the C_LIST Field in Two Trans Based MAC Protocol

If there is a code channel available, then the sender station changes the status of the bit to 1 and uses that code channel to transmit data packets. Once the transmission from the sender is completed, the receiver will change the status bit back to 0 when the token visits it. If all the codes are in use, the sender will have to wait for other stations to finish their transmissions before it may start sending its packets.

As shown in Table 5.3 and Table 5.4 (30 nodes, 15 CDMA codes) the token size in one transceiver based MAC scheme is 22.125 bytes, but in two transceiver based MAC scheme it is 78.375 bytes.

The other reason of this difference is that in two transceiver based MAC scheme, CDMA codes cannot be useable for a long time like the described scenario given below.

The node 1 is transferring packets to node 3 with CDMA code 2. When the transfer is finished the token visits node 4 as shown in Figure 5.5. Theoretically this code can be useable after transferring has ended, but practically it can be used only after the receiver node (node 3) will say that this CDMA code (code 2) is free from now on

and can be used. To say that the code 2 is free, node 3 has to wait to get the token. Time duration for the token to travel to node 3 can be calculated as follows.

$$T_T = \sum_{i=1}^N T_i^{trans} = 11,61 * 30 = 348,3 \text{ micro seconds}$$

$$T_i^{trans} = \frac{TokenSize}{ChannelCapacity} = \frac{78,375byte}{6,75Mbyte} = 11,61 \text{ micro seconds}$$

(Time taken to transmit the token from station i to the successor station $i+1$)

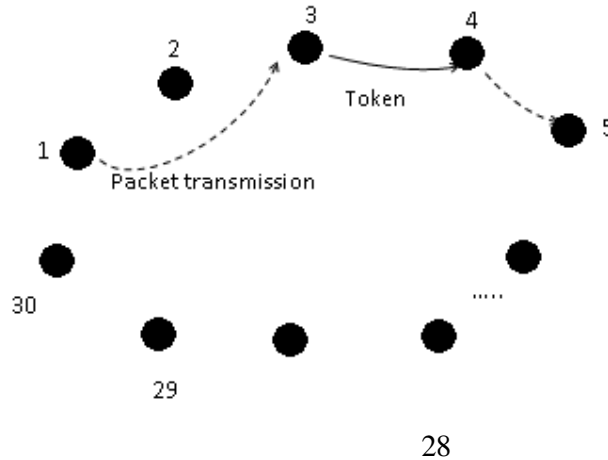

Figure 5.5: Illustration of Scenario where CDMA Code is Unusable

So the CDMA code 2 will be unusable during this duration (348,3 micro seconds). But in one transceiver based MAC scheme, CDMA codes will be freed at the beginning of each TTP duration. TTP time duration can be calculated as follows

$$T_T = \sum_{i=1}^N T_i^{trans} + T_b^{order} = 3,28 * 30 + 2,78 = 101,18 \text{ micro seconds}$$

$$T_i^{trans} = \frac{TokenSize}{ChannelCapacity} = \frac{22.125byte}{6,75Mbyte} = 3,28 \text{ micro seconds}$$

(Time taken to transmit the token from station i to the successor station $i+1$)

$$T_{SL} = \frac{SizeOfNodesOrder}{ChannelCapacity} = \frac{18,75byte}{6,75Mbyte} = 2,78 \text{ micro seconds}$$

(Time taken to broadcast the node orders information to all nodes in the network)

So the arbitrary CDMA code will be unusable during this TTP duration (101,18 micro seconds). There can be no results showing that any CDMA code can be unusable during the time duration bigger than calculated above.

Finally it can be said that using two transceivers, one for data transfer and one for token transfer, do not provide parallelism enough. If a node has a packet to send even though there are plenty of free CDMA codes, it must wait until token will travel it, which sometimes takes long time as described above.

Now, one transceiver based MAC scheme is compared to two transceiver based MAC scheme with the next system parameters.

Table 5.5: System Parameters (Increasing Load, Packet Size is 11,25 KB)

Symbol	Parameter
Number of nodes	30
Number of codes	15
Channel bit rate	54Mbps
Packet size	11.25 KB

The size of each packet in stream is 11,25KB (for bulk data retrieval) (C_i), the interarrival period between packets in the stream is 1000 micro seconds (P_i), the relative deadline of the packet in the stream is considered as unlimited (D_i) and also in each stream there are 30 - 300 packets. The graphical interpretation of these system parameters can be shown in Figure 5.4.

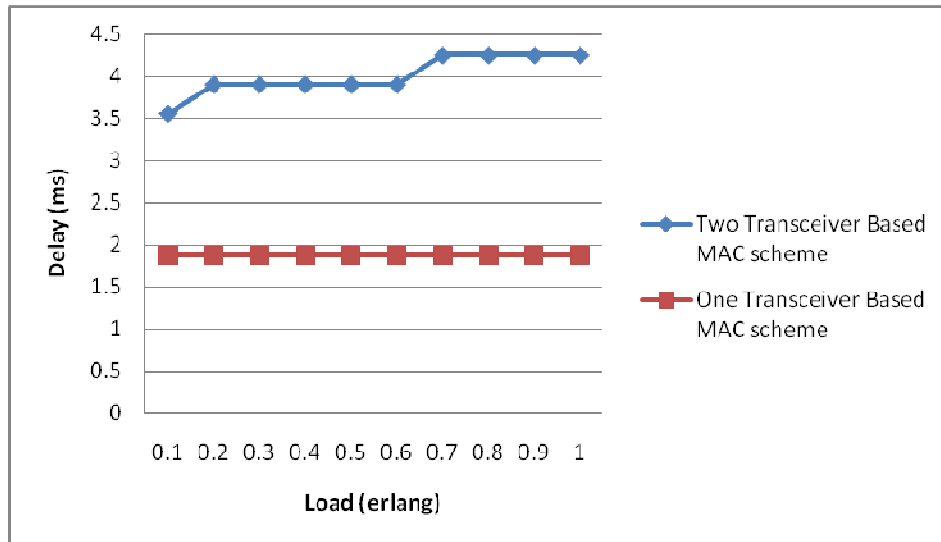

Figure 5.4: Maximum Packet Delay (Increasing Load, Packet Size is 11,25 KB)

The maximum packet delay in one transceiver based MAC scheme is constant and can be calculated with given equations in this section. But in two transceiver based

MAC scheme with increasing number of packets in the stream (increasing load) the maximum packet delay also can be increased.

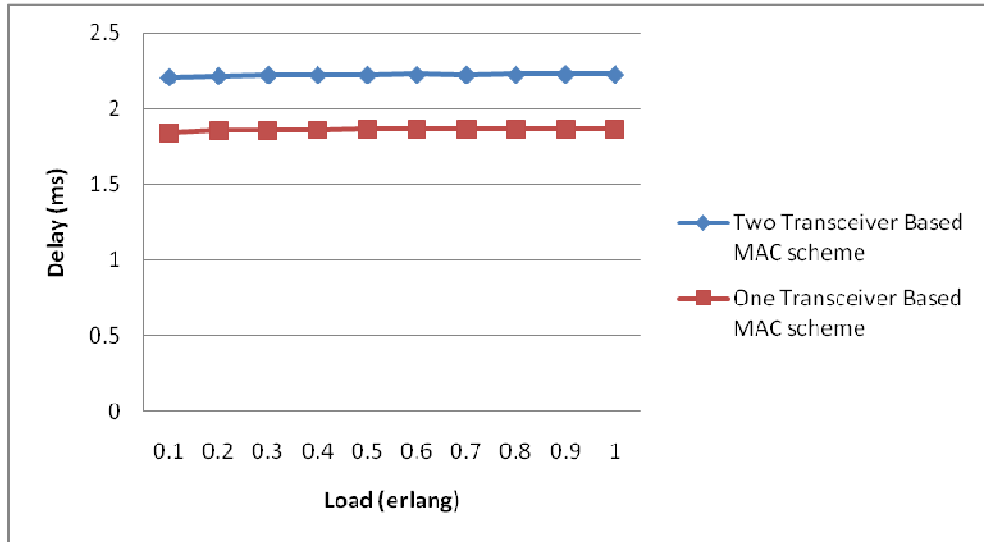

Figure 5.5: Average Packet Delay (Increasing Load, Packet Size is 11,25 KB)

Numerical results are shown in the following tables. As shown in these tables, in one transceiver based MAC scheme variance of the average packet delay is smaller than in two transceiver based MAC scheme.

The practical results for one transceiver based MAC scheme are shown in Table 5.6.

Table 5.6: Practical Results for given Parameters in One Trans Based MAC Scheme

Load	Maximum Packet Delay (ms)	Average Packet Delay (ms)	Variance	Total duration for trans. (s)	Packet Numbers
0.1	1.86936	1.83989	0.22636	0.1060908	30
0.2	1.86936	1.85463	0.16074	0.2121816	60
0.3	1.86936	1.85954	0.13143	0.3182724	90
0.4	1.86936	1.86199	0.1139	0.4243632	120
0.5	1.86936	1.86347	0.10192	0.530454	150
0.6	1.86936	1.86445	0.09306	0.6365448	180
0.7	1.86936	1.86515	0.08618	0.7426356	210
0.8	1.86936	1.86568	0.08062	0.8487264	240
0.9	1.86936	1.86609	0.07602	0.9548172	270
1	1.86936	1.86641	0.07213	1.060908	300

The practical results for two transceiver based MAC scheme are shown in Table 5.7.

Table 5.7: Practical Results for given Parameters in Two Trans Based MAC Scheme

Load	Maximum Packet Delay (ms)	Average Packet Delay (ms)	Variance	Total duration for trans. (s)	Packet Numbers
0.1	3.5575	2.20768	0.4229	0.11832912	30
0.2	3.9058	2.21598	0.37993	0.23678595	60
0.3	3.9058	2.22249	0.36689	0.35372187	90
0.4	3.9058	2.22275	0.3577	0.47093643	120
0.5	3.9058	2.22259	0.35472	0.589788	150
0.6	3.9058	2.22416	0.35051	0.70711866	180
0.7	4.2541	2.22352	0.34949	0.82548261	210
0.8	4.2541	2.22448	0.34887	0.94318479	240
0.9	4.2541	2.22704	0.34555	1.06136298	270
1	4.2541	2.22568	0.34372	1.17684765	300

With increasing load in the network the total time duration difference for transmitting all packets in the system between these two schemes is increasing as shown in these tables.

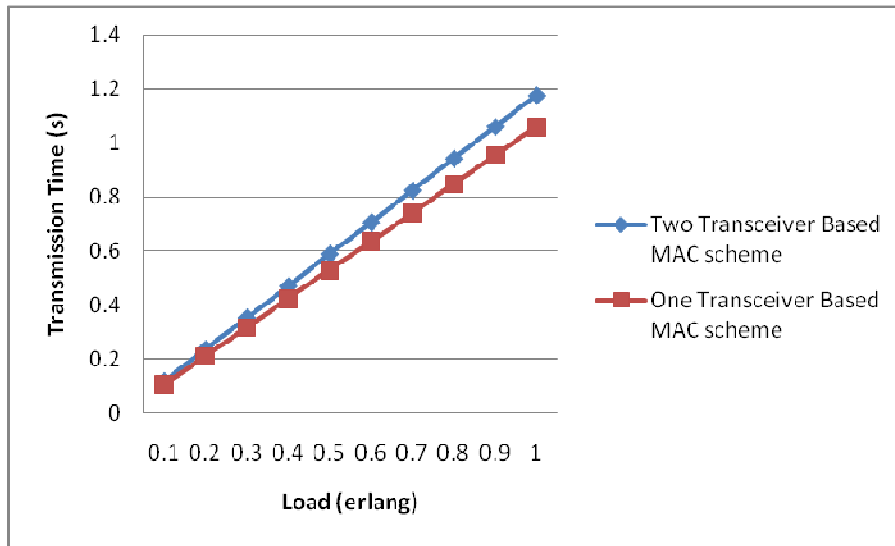

Figure 5.6: Time Duration for Transmitting All Packets in the Network (Increasing Load, Packet Size is 11,25 KB)

In addition, these two schemes are furthered analyzed with next parameters.

Table 5.8: System Parameters (Increasing Load, Packet Size is 128 KB)

Symbol	Parameter
Number of nodes	30
Number of codes	15
Channel bit rate	54 Mbps
Packet size	128 KB

The size of each packet in stream is 128KB (for audio transmitting) (C_i), the interarrival period between packets in the stream is 1000 micro seconds (P_i), the relative deadline of the packet in the stream is considered as unlimited (D_i) and also in each stream there are 3 - 30 packets.

Table 5.9: Practical Results for given Parameters in Two Trans Based MAC Scheme

Load	Maximum Packet Delay (ms)	Average Packet Delay (ms)	Variance	Total duration for trans. (s)	Packet Numbers
0.1	20.7432	16.26497	7.23771	0.11606517	3
0.2	21.0915	17.92745	5.38555	0.23209551	6
0.3	21.0915	18.48032	4.46855	0.3479517	9
0.4	21.4398	18.75386	3.90312	0.46380789	12
0.5	21.4398	18.91875	3.50968	0.57975696	15
0.6	22.1364	19.03771	3.22182	0.69597306	18
0.7	22.1364	19.11881	2.99167	0.81198018	21
0.8	22.1364	19.18351	2.80708	0.92754612	24
0.9	22.1364	19.23426	2.6514	1.04346036	27
1	22.1364	19.2737	2.51915	1.15939782	30

Table 5.10: Practical Results for given Parameters in One Trans Based MAC Scheme

Load	Maximum Packet Delay (ms)	Average Packet Delay (ms)	Variance	Total duration for trans. (s)	Packet Numbers
0.1	19.16536	15.988	7.1048	0.11438508	3
0.2	19.16536	17.57668	5.26906	0.22877016	6
0.3	19.16536	18.10624	4.36687	0.34315524	9
0.4	19.16536	18.37102	3.80952	0.45754032	12
0.5	19.16536	18.52989	3.42213	0.5719254	15
0.6	19.16536	18.6358	3.13292	0.68631048	18
0.7	19.16536	18.71145	2.90644	0.80069556	21
0.8	19.16536	18.76819	2.72286	0.91508064	24
0.9	19.16536	18.81232	2.57017	1.02946572	27
1	19.16536	18.84762	2.44058	1.1438508	30

The graphical interpretation of these system parameters are shown in Figure 5.7, 5.8 and 5.9.

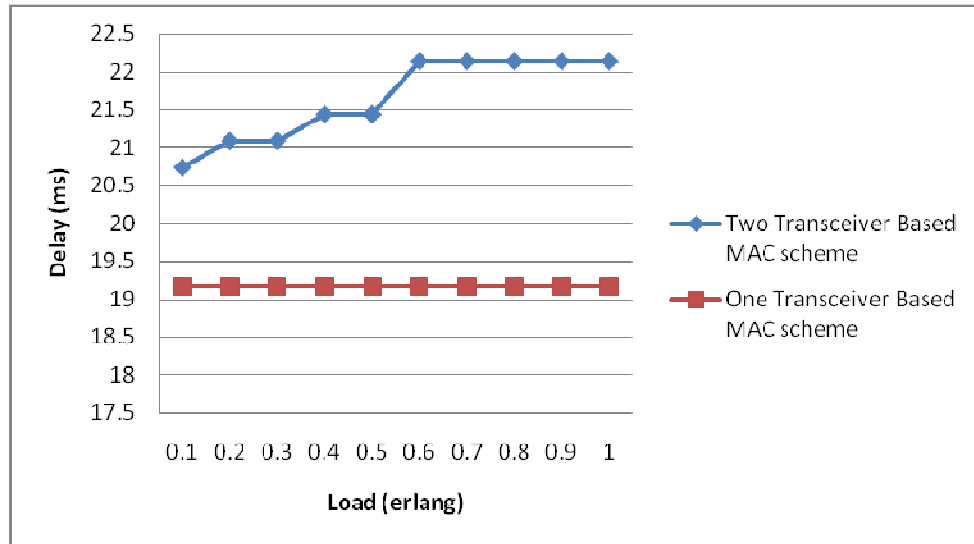

Figure 5.7: Maximum Packet Delay (Increasing Load, Packet Size is 128 KB)

As described below the maximum packet delay in one transceiver based MAC scheme is constant, do not increase with increasing network load.

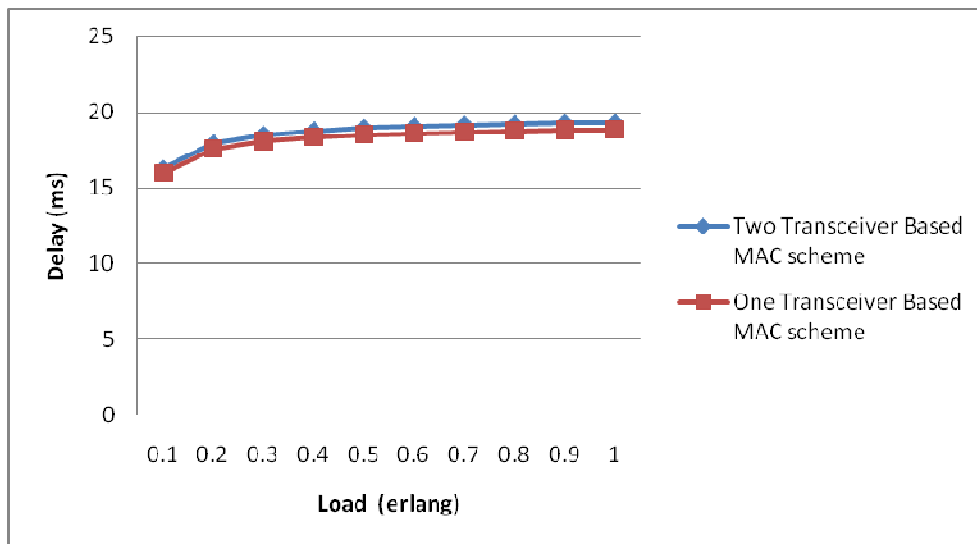

Figure 5.8: Average Packet Delay (Increasing Load, Packet Size is 128 KB)

In this type of packets (128 KB) these two MAC schemes show nearly the same performance. The average packet delays are approximately the same, only the variances for these delays in one transceiver based scheme are little smaller than two transceiver based MAC scheme.

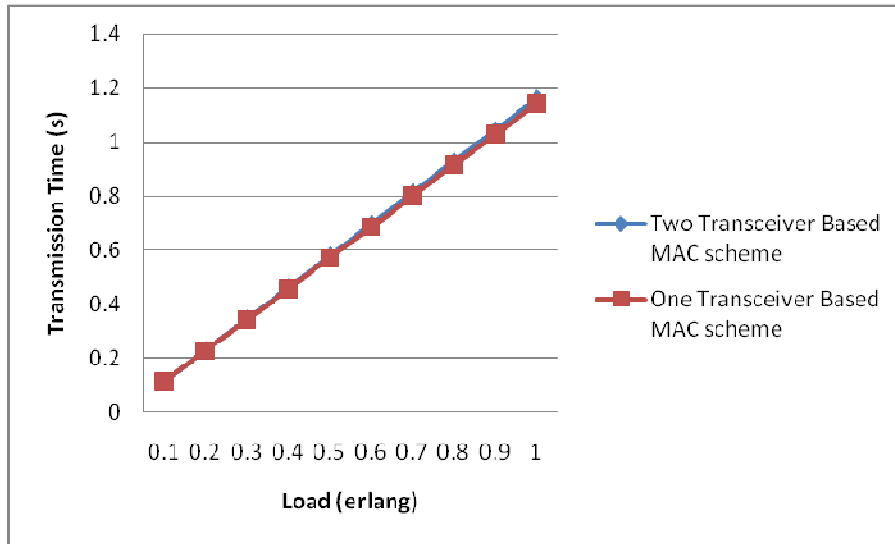

Figure 5.9: Time Duration for Transmitting All Packets in the Network (Increasing Load, Packet Size is 128 KB)

Finally these two MAC schemes are compared with smaller packet sizes.

Table 5.11: System Parameters (Increasing Load, Packet Size is 3,375 KB)

Symbol	Parameter
Number of nodes	30
Number of codes	15
Channel bit rate	54 Mbps
Packet size	3,375 KB

The size of each packet in stream is 3,375 KB (control information) (C_i), the interarrival period between packets in the stream is 100 micro second (P_i), the relative deadline of the packet in the stream is considered as unlimited (D_i).

Table 5.12: Practical Results for given Parameters in Two Trans Based MAC Scheme

Load	Maximum Packet Delay (ms)	Average Packet Delay (ms)	Variance	Total duration for trans. (s)	Packet Numbers
0.1	3.6796	0.90929	0.47252	0.14954841	100
0.2	5.0728	0.92086	0.49216	0.29220048	200
0.3	5.0728	0.92341	0.49367	0.43828911	300
0.4	5.0728	0.92279	0.48847	0.58051161	400
0.5	5.0728	0.92191	0.48691	0.72547407	500
0.6	5.0728	0.92135	0.48201	0.87120279	600
0.7	5.0728	0.92117	0.48184	1.01175345	700
0.8	5.0728	0.92173	0.48338	1.15405722	800
0.9	5.0728	0.9216	0.4833	1.30377978	900
1	5.0728	0.92236	0.48245	1.44895122	1000

Table 5.13: Practical Results for given Parameters in One Trans Based MAC Scheme

Load	Maximum Packet Delay (ms)	Average Packet Delay (ms)	Variance	Total duration for trans. (s)	Packet Numbers
0.1	0.70236	0.69935	0.0424	0.120236	100
0.2	0.70236	0.70086	0.03002	0.240472	200
0.3	0.70236	0.70136	0.02452	0.360708	300
0.4	0.70236	0.70161	0.02124	0.480944	400
0.5	0.70236	0.70176	0.019	0.60118	500
0.6	0.70236	0.70186	0.01735	0.721416	600
0.7	0.70236	0.70193	0.01606	0.841652	700
0.8	0.70236	0.70198	0.01502	0.961888	800
0.9	0.70236	0.70203	0.01417	1.082124	900
1	0.70236	0.70206	0.01344	1.20236	1000

As shown in these tables, the main advantages of one transceiver based MAC scheme from two transceiver based MAC scheme are that the maximum packet delay is smaller and constant, and also the variances of average packet delays are smaller than in two transceiver based MAC scheme.

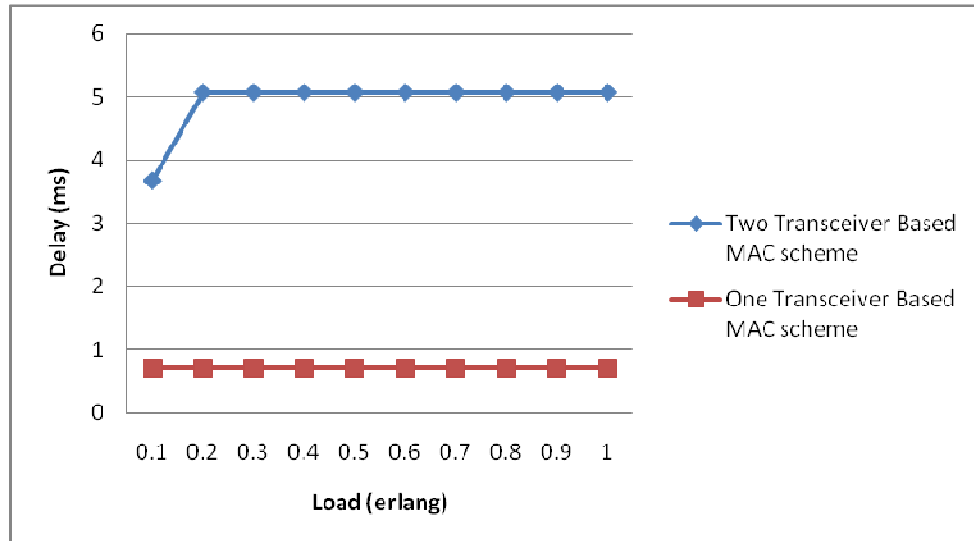

Figure 5.10: Maximum Packet Delay (Increasing Load, Packet Size is 3,375 KB)

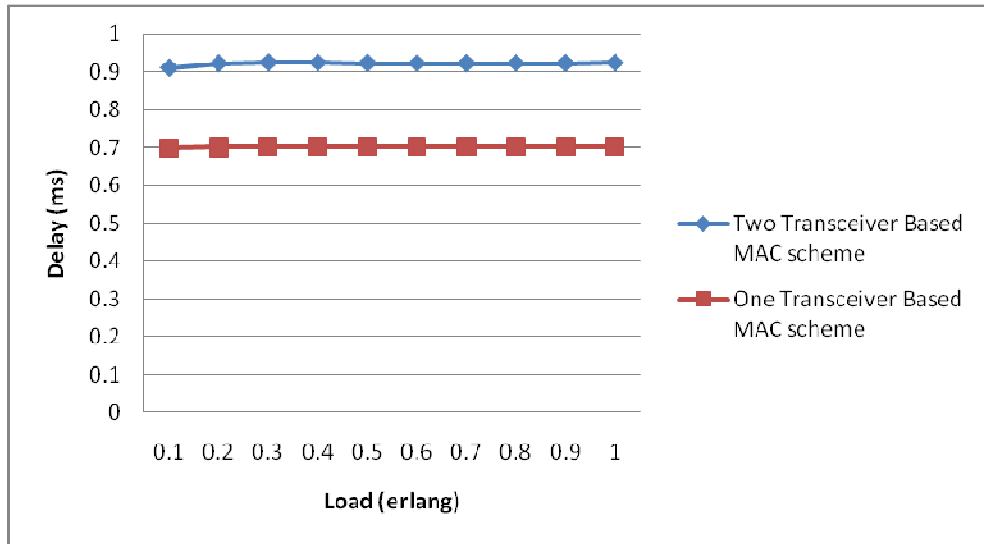

Figure 5.11: Average Packet Delay (Increasing Load, Packet Size is 3,375 KB)

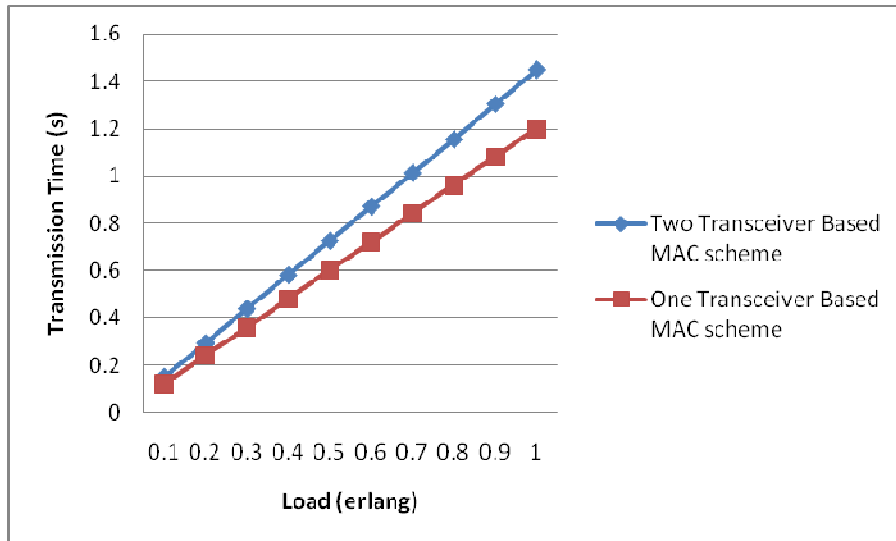

Figure 5.12: Time Duration for Transmitting All Packets in the Network (Increasing Load, Packet Size is 3,375 KB)

Additional to this performance analysis of these two protocols, the system which has the MUD hardware and using the proposed MAC scheme in this thesis is compared with the system which doesn't have the MUD hardware.

The system parameters are given in Table 5.14.

Table 5.14: System Parameters (Increasing CDMA Code Numbers)

Symbol	Parameter
Number of nodes	30
Number of codes	2,3,5,6,10,15
Channel bit rate	54 Mbps
Packet size	11,25 KB

The size of each packet in stream is 11,25 KB (for bulk data retrieval) (C_i), the interarrival period between packets in the stream is 100 micro seconds (P_i), the relative deadline of the packet in the stream is considered as unlimited (D_i) and also in each stream there are 100 packets.

Table 5.15: Practical Results for given Parameters in System which has MUD

CDMA codes	Maximum Packet Delay (ms)	Average Packet Delay (ms)	Variance	Total duration for trans. (s)
2	24.8287	24.70505	1.44775	2.64957
3	16.0028	15.92329	0.93995	1.76698
5	8.93848	8.89429	0.53333	1.060548
6	7.1709	7.13555	0.43152	0.88379
10	3.63754	3.61986	0.22759	0.530454
15	1.86936	1.86052	0.12472	0.353636

Table 5.16: Practical Results for given Parameters in System which doesn't have MUD

CDMA codes	Maximum Packet Delay (ms)	Average Packet Delay (ms)	Variance	Total duration for trans. (s)
2	77.965	24.21045	6.19616	2.6579392
3	69.8362	15.26794	5.86914	1.79294274
5	41.659	8.32325	4.31634	1.08856575
6	34.438	6.5872	3.7816	0.90804075
10	31.14556	3.14855	2.90026	0.57786564
15	34.7914	1.58327	2.57665	0.41380284

The graphical interpretation of given system parameters are shown below:

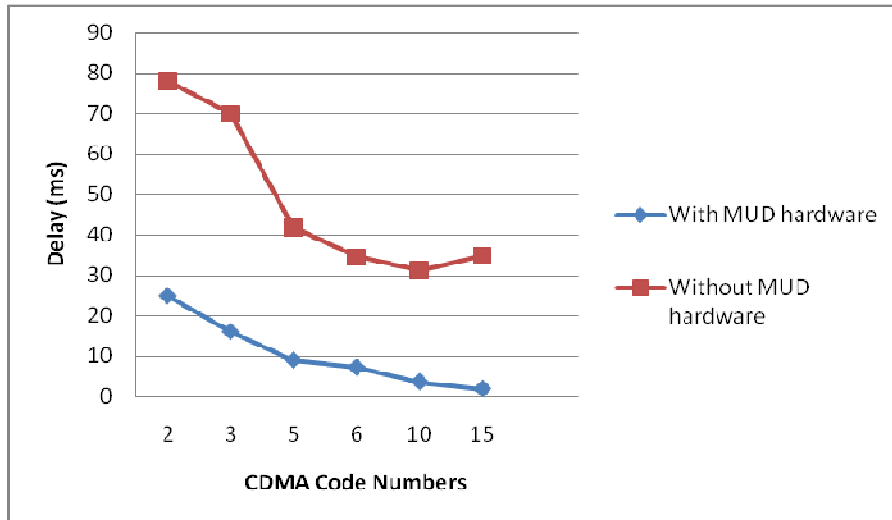

Figure 5.13: Maximum Packet Delay (Increasing Code Numbers)

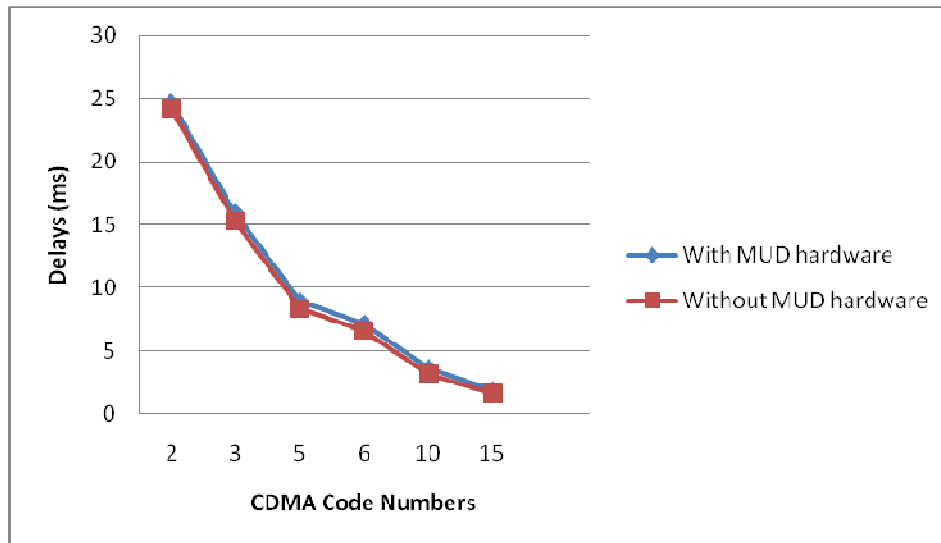

Figure 5.14: Average Packet Delay (Increasing Code Numbers)

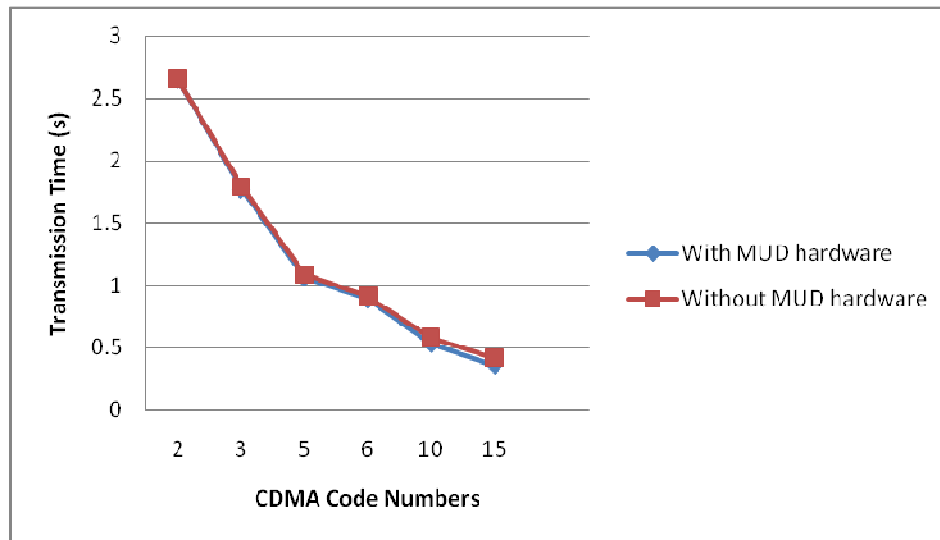

Figure 5.15: Time Duration for Transmitting All Packets in the Network (Increasing Code Numbers)

One difference between these two systems is maximum packet delay, which is smaller in systems which have MUD hardware than that one. As shown in Table 5.15 and 5.16, the other difference is the variances for average packet delays. In systems which have MUD hardware these variances are much smaller than in systems which don't have MUD hardware. These advantages of system which have MUD hardware makes it more deterministic.

Finally, ordering methods which described in section 5.1 is compared with next system parameters.

Table 5.17: System Parameters (Increasing Load, Packet Size is 11,25)

Symbol	Parameter
Number of nodes	30
Number of codes	15
Channel bit rate	54 Mbps
Packet size	11,25 KB

The size of each packet in stream is 11,25 KB (for bulk data retrieval) (C_i), the interarrival period between packets in the stream is 100 micro seconds (P_i), the relative deadline of the packet in the stream is considered as unlimited (D_i) and also in each stream there are 30 – 300 packets. Each system has MUD hardware.

Two ordering methods, normal ordering and special ordering, which considers available CDMA codes when making access order, is compared. Normal ordering method is like this:

1,2,3...,30; 2,3...,30,1 ; 3,4,5...,30,1,2; ... ; 30,1,2,3...,29; after each period station which in the first place of the list goes to the last place in the list.

Special ordering is little different, it changes station places' with number of CDMA codes. For example, assume that there 5 CDMA codes in the network then the channel access order of stations will change as follows:

1,2,3,4,5,...30; 6,7,8,9,10,...,30,1,2,3,4,5; ...; 26,27,28,29,30,1...,23,24,25;

So the practical results for given system parameters are as follows:

Table 5.18: Practical Results for given Parameters in Normal Ordering

Load	Maximum Packet Delay (ms)	Average Packet Delay (ms)	Variance	Total duration for trans. (s)	Packet Numbers
0.1	26.62388	1.6336	6.02912	0.1060908	30
0.2	26.62388	1.75148	6.33042	0.2121816	60
0.3	26.62388	1.79077	6.42724	0.3182724	90
0.4	26.62388	1.81042	6.47502	0.4243632	120
0.5	26.62388	1.82221	6.50348	0.530454	150
0.6	26.62388	1.83007	6.52238	0.6365448	180
0.7	26.62388	1.83568	6.53584	0.7426356	210
0.8	26.62388	1.83989	6.54592	0.8487264	240
0.9	26.62388	1.84316	6.55374	0.9548172	270
1	26.62388	1.84578	6.55999	1.060908	300

Table 5.19: Practical Results for given Parameters in Special Ordering

Load	Maximum Packet Delay (ms)	Average Packet Delay (ms)	Variance	Total duration for trans. (s)	Packet Numbers
0.1	1.86936	1.83989	0.22636	0.1060908	30
0.2	1.86936	1.85463	0.16074	0.2121816	60
0.3	1.86936	1.85954	0.13143	0.3182724	90
0.4	1.86936	1.86199	0.1139	0.4243632	120
0.5	1.86936	1.86347	0.10192	0.530454	150
0.6	1.86936	1.86445	0.09306	0.6365448	180
0.7	1.86936	1.86515	0.08618	0.7426356	210
0.8	1.86936	1.86568	0.08062	0.8487264	240
0.9	1.86936	1.86609	0.07602	0.9548172	270
1	1.86936	1.86641	0.07213	1.060908	300

There is a big difference between maximum packet delays; the system which uses special ordering for channel access is showing better performance than other system.

The main advantage of the system which uses special ordering for channel access is that the variances for average packet delays are very small when compared to the other system. In each system total time duration for transmitting all packets in the network is the same. Also in each system the maximum packet delay is constant.

The graphical interoperation of the average packet delay can be shown as follows.

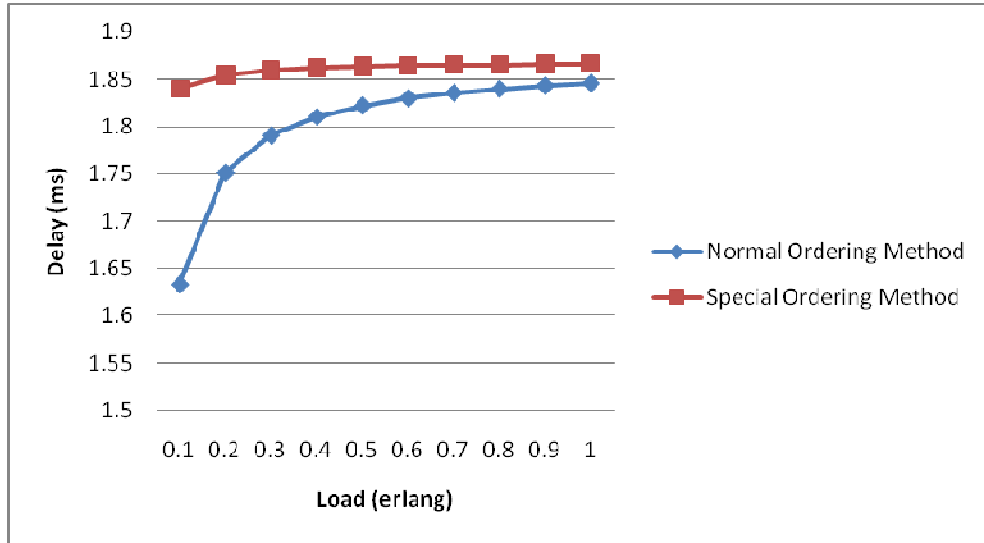

Figure 5.16: Average Packet Delay (Increasing Load, Packet Size is 3,375 KB)

This special ordering method does not work well in systems which don't have MUD hardware. In these systems packet delays depend on destination address, so to make the effective channel access order the destination address of the packet must be known which is not possible for ad hoc networks.

6. CONCLUSION

In this thesis, to support real-time communications, one transceiver based a hybrid Token-CDMA MAC protocol is proposed. Unlike the conventional token based MAC protocols, in the proposed MAC scheme the token is used to distribute CDMA codes in the network. The token scheme provides guaranteed access for each node in the network, and CDMA scheme is implemented to support multiple simultaneous data transmissions. The reason for using the token based protocol is that, it has special timing properties and solid mathematical foundations. It is designed to be used for hard real-time communications and also extensive amount of research has been done on token based protocol especially on SBA (Synchronous Bandwidth Allocation) schemes and as a result it has been well understood in the research community. And also the upper bound for the delay is known and hence the system becomes predictable which is the primary requirement for real-time systems.

Important features of this proposed MAC scheme are that it uses one transceiver for each node which decreases the hardware cost, provides real time guarantees and exploits the availability of multiple transmissions.

Various performance measures of proposed MAC scheme are compared with two transceiver based Token-CDMA based MAC scheme under the same simulation conditions. Our MAC scheme uses only one transceiver for each node which decreases the hardware cost.

Besides the transceiver, hardware as MUD capabilities is also incorporated in two transceiver based MAC protocol, in order to be able to receive multiple transmissions simultaneously. This MAC scheme cannot work without this hardware, but our protocol can work with or without MUD hardware.

Simulations showed that proposed MAC protocol in this thesis which is based on time division scheme (using only one transceiver for each node) is showing much better performance in systems having shorter frame lengths (like 3,375K and etc.) than the MAC protocol which based on frequency division scheme (using two

transceivers for each node). So, our protocol shows better performance when using it in Wireless Industrial Control Networks (WICN). WICN is a single hop ad hoc network with the next properties:

- Frame lengths are shorter
- Multi path fading is observed
- The network has a small radius and so mobility is limited in a small region
- The network should be integrated with upper layers in the intranet

Additionally, a system which has MUD hardware and uses our protocol is compared to the system which doesn't have MUD hardware. From simulation results it can be said that using MUD hardware in the network increases network performance, and makes the system more deterministic.

Finally, the system which uses special ordering method for channel access is compared with the system using normal ordering method for channel access. Simulation results showed that using special methods for channel access order increases network performance. These methods can be done considering available CDMA codes in the network, or giving some stations high priority than others and etc.

6.1 Future Work

In the proposed MAC scheme the main problem is that the mobility of nodes in the network is not considered (multi ring topology). Making the system suitable for supporting mobility is an open challenge. The mobility scenario will include more than one virtual ring and hence this will also bring the problem of multiple ring management. Consider the multi ring topology in Figure 6.1. There is a gateway connecting the two wireless virtual rings. This gateway can be a hop leader or some node in the network. Assume that the Node A in the figure has a packet for Node B in another virtual ring. The problem gets more challenging because in order to provide transmission, knowledge of the state of both wireless virtual rings is required (available free CDMA codes). Free CDMA code in each virtual ring can be selected for transmission like selecting light path in optical networks, or some conversion between CDMA codes can be used in gateway. And more importantly this

transmission should not degrade any station's real-time guarantees in any of the virtual ring networks. And also in these multi-ring network topologies latency guarantees are harder to determine.

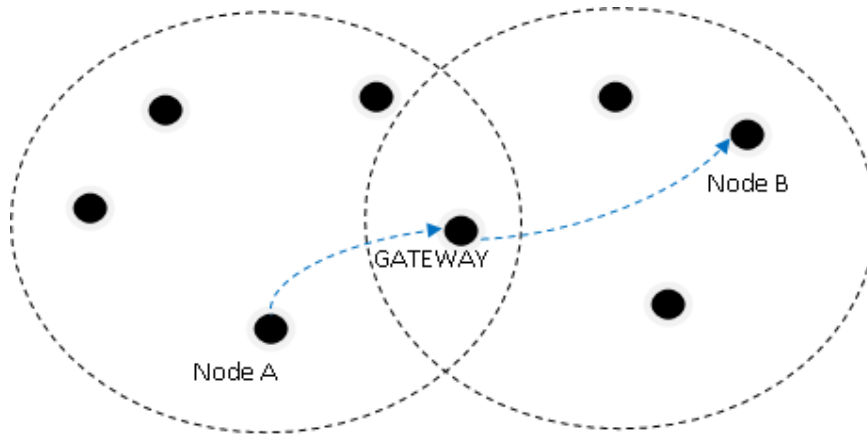

Figure 6.1: Multi Ring Network Topology

REFERENCES

- [1] **J. D. Spragins, J. L. Hammond, and K. Pawlikowski**, 1994, Telecommunications, Protocols and Design. Reading, MA: Addison-Wesley.
- [2] **F. A. Tobagi and L. Kleeinrock**, 1975, Packet switching in radio channels: Part II. The hidden terminal problem in carrier sense multiple-access modes and the busy-tone solution, *IEEE Transactions on Communications*, vol. COM-23, no. 12, pp. 1417-1433.
- [3] **P. Karn**, 1990, MACA-A new channel access method for packet radio, in *Proc. ARRL/CRRL Amateur Radio 9th Computer Networking Conf.*, pp. 134-140.
- [4] **C. R. Lin and M. Gerla**, 1997, MACA/PR: An asynchronous multimedia multi hop wireless network, in *Proc. IEEE INFOCOM. 97*, Apr.
- [5] **F. Talucci and M. Gerla**, 1997, MACA-BI (MACA By Invitation) A wireless MAC protocol for high speed ad hoc networking, in *Proc ICUPC. 97*, Nov.
- [6] **J. Deng and Z. J. Hass**, 1998, Dual busy tone multiple access (DBTMA): A new medium access method for packet radio networks, in *Proc. Int. Conf. Universal Personal Commun.*, Oct.
- [7] **IEEE Standards 802.5-1989**. Token Ring Access Method and Physical Layer Specifications. *The Institute of Electrical and Electronic Engineers, Inc.*
- [8] **ANSI Standard X3T9.5**, 1987, Fiber Distributed Data Interface (FDDI). Token Ring Medium Access Control (MAC), May.
- [9] **L. Donatiello and M. Furini**, 2003, Ad Hoc Networks: A Protocol for supporting QoS applications, in *IEEE International Symposium on Parallel and Distributed Processing 2003*, April, pp. 219-226.
- [10] **N. Malpani, Y. Chen, N. Vaidya and J. Welch**, 2005, Distributed token circulation in mobile ad hoc networks, *IEEE Transaction on Mobile Computing*, Vol. 4, No. 2, March, pp. 154-165.

- [11] **V. Rajagopalan and P. McKinley**, 1989, A Token-based protocol for reliable, ordered multicast communication, *Proc. Eighth IEEE Symp. Reliable Distributed Systems*, October, pp. 84-93.
- [12] **M. Ergen, D. Lee, R. Sengupta and P. Varaiya**, 2003, Wireless token ring protocol-performance comparison with IEEE 801.11, *IEEE International symposium on Computers and Communications (ISCC'03)*, vol. 3, pp. 710-715.
- [13] **M. Ergen, D. Lee, R. Sengupta and P. Varaiya**, 2004, WTRP- Wireless token ring protocol, *IEEE Transactions on Vehicular Technology*, vol. 53, no. 6, pp. 1863-1881.
- [14] **M. Takahashi, Y. Komoriya, I. Sasase, and T. Arita**, 2001, A medium access control protocol with token passing and retransmission by the hub station in the asynchronous transfer mode of wireless 1394, in *IEEE Global Telecommunications Conference (GLOBECOM) 2001* November, vol. 6, pp. 3728-3732.
- [15] **R. L. Davies, R. M. Watson, A. Murno, and M. H. Barton**, 1995, Ad-Hoc wireless networking: contention free multiple access using token passing, in *IEEE 45th Vehicular Technology Conference (VTC) 1995* July, vol. 1, pp. 361-365.
- [16] **L. Donatiello and M. Furini**, 2002, Design and analysis of RT-Ring: A protocol for supporting real-time applications, *IEEE Transaction on Industrial Electronics*, December, vol. 49, no. 6, pp. 1214-1226.
- [17] **A. Willig, M. Kubischg, C. Hoene, and A. Wolisz**, 2002, Measurements of a wireless link in an industrial environment using an IEEE 802.11-Compliant physical layer, *IEEE Transaction on Industrial Electronics*, December, vol. 49, no. 6, pp. 1265-1282.
- [18] **K. L. Blackard, T. S. Rappaport, and C. W. Bostian**, 1993, Measurements and models of radio frequency impulsive noise for indoor wireless communications, *IEEE Journal on Selected Areas in Communications*, September, vol. 11, no. 7, pp. 991-1001.
- [19] **A Willig, and A. Wolisz**, 2001, Ring stability of the PROFIBUS token-passing protocol over error-prone links, *IEEE Transaction on Industrial Electronics*, October, vol. 48, no. 5, pp. 1025-1033.

- [20] **I-Sheng Liu, Fambirai Takawira, and Hong-Jun Xu**, 2008, A hybrid token based CDMA MAC protocol for wireless ad hoc networks, *IEEE Transactions on Mobile Computing*, May, **vol. 7**, no. 5, pp 557-569.
- [21] **Q. Qu, R. Appuswamy and Y. Chan**, 2006, QoS guarantee and provisioning for realtime digital video over mobile ad hoc CDMA networks with cross-layer design, *IEEE Transaction on wireless communications*, **Vol. 13**, Issue. 5, pp. 82-88.
- [22] **A. Butala and L. Tong**, 2005, Cross-layer design for medium access control in CDMA Ad Hoc networks, *EURASIP Journal on Applied Signal Processing*, **Vol. 20**, No. 2, pp. 129-143.
- [23] **S. Lal and E. Sousa**, 1999, Distributed resource allocation for DS-CDMA based multimedia ad hoc wireless LANs, *IEEE Journal on selected areas in communications*, **Vol. 17**, Issue 5, pp. 947-967.
- [24] **Zaihan Jiang and MengChu Zhou**, 2006, Dynamic bandwidth allocation with collision avoidance MAC design for mobile ad hoc network, *IEEE*.
- [25] **J. G. Proakis**, 2001, Digital Communications, McGraw-Hill, New York.
- [26] **C.-K. Toh**, 2002, Ad Hoc Mobile Wireless Networks, *Prentice-Hall PTR, NJ*.
- [27] **Charles E. Perkins**, 2001, Ad Hoc Networking, Addison Wesley, Reading, MA.
- [28] **Akyıldız I., Melodia, T. and Chowdhury, K.**, 2007. A Survey on Wireless Multimedia Sensor Networks, *The International Journal of Computer and Telecommunications Networking*, **51**, 921-960.
- [29] **L. Kleinrock, F. A. Tobagi**, 1975, Packet switching in radio channels: Part I-carrier sense multiple access modes and their throughput-delay characteristics, *IEEE Trans. Commun.* 23 (Dec) (1975) 1400-1416.
- [30] **Sunil Kumar, Vineet S. Raghavan, Jing Deng**, 2006, Medium Access Control protocols for ad hoc wireless networks: A survey, *ELSEVIER, Ad Hoc Networks* 4, pp. 326-358.
- [31] **T. Ojanpera, R. Prasad**, 1998, Wideband CDMA For Third Generation Mobile Communications, Artech House, Norwood, MA.
- [32] **K. S. Gilhousen, I. M. Jacobs, R. Padovani, A. J. Viterbi, L. A. Weaver, C. E.** 1991, Wheatley III, On the capacity of a cellular CDMA system, *IEEE Transactions on Vehicular Technology* 40 (1991) 303-312.

- [33] **L. Hu**, 1993, Distributed code assignments for CDMA packet radio networks, *IEEE/ACM Transactions on Networking* 1 (1993) 668-677.
- [34] **E. Sousa, J. A. Silvester**, 1998, Spreading code protocols for distributed spread-spectrum packet radio networks, *IEEE Transactions on Communications* 36 (3) (1998) 272-281.
- [35] **V. Bhargavan, A. Demers, S. Shenker, L. Zhang**, 1994, MACAW-A Media Access protocol for wireless Lans, *in: Proceedings of the ACM SIGCOMM, 1994*, pp. 212-225.
- [36] **C. L. Fullmer, J. J. Garcia-Luna-Aceves**, 1995, Floor Acquisition Multiple Access (FAMA) for packet-radio networks, *in: Proc. ACM SIGCOMM, Cambridge MA, August 28-September 1*.
- [37] **W. Ye, J. Jeidemann, D. Estrin**, 2002, An energy-efficient MAC protocol for wireless sensor networks, *in: Proceedings of the IEEE INFOCOM*.
- [38] **G. Sidhu, R. Andrews, A. Oppenheimer**, 1989, Inside Apple-Talk, Addison-Wesley, Reading, MA.
- [39] **Hang Su and Xi Zhang**, 2007, An efficient single-transceiver CDMA-based MAC protocol for wireless networks, *26th IEEE International Conference on Computer Communications. IEEE Volume , Issue , 6-12 May 2007* pp. 1487-1495.
- [40] **S. Lee and D. Cho**, 1995, Distributed reservation CDMA for wireless LAN, *in Proc. of Globecom, Vol. 1, 1995*. pp. 360-364.
- [41] **A. Muqattash and M. Krunz**, 2003, CDMA-based MAC protocol for wireless ad hoc networks, *in Proc. of MobiHoc'03, June 2003, USA*.

APPENDIX A

Pseudo code of the algorithm

The pseudo code of the proposed MAC-scheme is shown below.

```
TotalTime // shows the current time.

DATA_PERIOD // shows the duration which is dedicated for data
              transferring at each beacon interval.

Token_Transmitting_Time // the time which is needed to transfer the
                        token to the next station.

Packet.TransmittingTime // the time for transferring the packet to
                        the intended receiver.

Packet.ArrivalTime // shows packet's arrival time to the queue.

Token_Processing_Time // shows how much time is needed to reserve
                      CDMA code for data transferring.

PacketDelay // calculates the packet delay (destination_time-
arrival_time)

while (IsThereAnyPacket())
{
    if (BIC == UPDATE_NETWORK)
    {
        StartInsertionAlgorithm();
    }

    CreateStationList();
    BroadcastStationList();
    CreateToken();

    for (int i = 1; i <= NumberOfNodes; i++)
    {
        GetToken(i);
        ProcessToken(i);
        SendToken(i);
    }
    BroadcastToken();

    for (int k = 1; k <= NumberOfNodes; k++)
    {
        TurnReceiverToAdaptedCode(k);
    }

    for (int j = 1; j <= NumberOfNodes; j++)
    {
        SendPacket(j);
    }

    TotalTime = TotalTime + DATA_PERIOD;
}
}
```



```

CreateStationList()// STATION_LIST is crated by hop leader at the
beginning of each becaon interval.

BroadcastStationList()//STATION_LIST is broadcasted by hop leader to
all stations in the network.

CreateToken() // Token is created by hop leader.
GetToken() // Station gets the token.

SendToken() //Station transmits the token to the next station in the
STATION_LIST.
{
    TotalTime = TotalTime + Token_Transmitting_Time;
}

BroadcatToken ()// Hop leader broadcasts token's last situation to
all stations in the network
{
    TotalTime= TotalTime + Token_Transmitting_Time;
}

TurnReceiverToAdaptedCode()//Station adjusts its receiver to the
dedicated CDMA code in the token
{
    if (Token.C_List[NodeIndex] != 0)
    {
        Node[NodeIndex].ReceiverCode = Token.C_List[NodeIndex];
    }
}

TokenProcessingTime()// Token is processed by the station which it
visited.
{
    if ( IsPacket) // if there is a packet to send
    {
        if (FreeCode) // if there is a free CDMA code
        {
            if (!DestinationNodeIsBusy) // if the intended
receivrer is not reserved for another transferring
            {
                Token.C_List[DestinationNode]= SelectedCode();
                //Informs the intended receiver that which CDMA
code will be used for the packet transmission.
            }
        }
        TotalTime= TotalTime+Token_Processing_Time;
    }
}

SendPacket()// Packet is sent by the intended sender.
{
    TurnTransmitterToAdaptedCode()

    delay= Packet.LeveTimeFromQueue -
        Packet.ArrivalTimeToFirstPlace;

    If(delay > packet_delay)
    {
        Packet is lost;
    }
}

```

```

        else
        {
            PacketDelay=delay;
        }
    }

TurnTransmitterToAdaptedCode()//Station adjusts its transmitter to
the selected CDMA code for the transmission.

StartInsertionAlgorithm() // Starts new station insertion algorithm
{
    BroadcastNODE_WELCOME_MESSAGE();
    Wait for (REQUEST_Timer)
    {
        If (NewNode) // if there is a new node intending to join
the network replies to NODE_WELCOME_MESSAGE
        {
            SendAckToNewNode()//Accepts joining of a new node
            InsertNewNodeToStationList()//inserts an address
of new node to the STATION_LIST, which will be
broadcasted to all nodes
            break;
        }
    }
}

```

BIOGRAPHY

Elnur Isayev was born in Baku, Azerbaijan in 1984. Raised in Baku, he started his education at Rovsen Aliyev High School. After 6 years, he get a chance to carry on his education at the Zengi Private High School. He has received his B.Sc. degree from Computer Engineering Department of Baku State University in 2004. After obtaining a B.Sc. degree, he carried on to study at Istanbul Technical University the M.Sc. Program in Computer Engineering in 2005. After completing his thesis and upon obtaining the M.Sc. degree, it is his wish to become a software architecture designer in his professional work career.