

**THEORETICAL MODELING AND DESIGNING
A LINE-FOCUSED HORIZONTAL –RECEIVER-
SOLAR THERMAL POWER PLANT**

**A Thesis Submitted to
the Graduate School of Engineering and Sciences of
İzmir Institute of Technology
in Partial Fulfillment of the Requirements for the Degree of**

MASTER OF SCIENCE

in Energy Engineering

**by
Osman Can YAZICI**

**October, 2005
İZMİR**

We approve the thesis of **Osman Can YAZICI**

Date of Signature

26 October 2005

Assist. Prof. Dr. Bedrettin SUBAŞILAR
Supervisor
Department of Physics
İzmir Institute of Technology

26 October 2005

Assoc. Prof. Dr. Orhan ÖZTÜRK
Co-Supervisor
Department of Physics
İzmir Institute of Technology

26 October 2005

Assist. Prof. Dr. Gülden GÖKÇEN
Department of Mechanical Engineering
İzmir Institute of Technology

26 October 2005

Prof. Dr. Ali GÜNGÖR
Department of Mechanical Engineering
Ege University

26 October 2005

Prof. Dr. Oktay PASHAEV
Department of Mathematics
İzmir Institute of Technology

26 October 2005

Assist. Prof. Dr. Gülden GÖKÇEN
Head of Department
İzmir Institute of Technology

Assoc. Prof. Dr. Semahat ÖZDEMİR
Head of the Graduate School

ACKNOWLEDGEMENTS

First of all, I particularly would like to thank my advisor, Assist. Prof. Dr. Bedrettin SUBAŞILAR and co-adviser Assoc. Prof. Dr. Orhan ÖZTÜRK, for their continuous guidance, support and vision that they never hesitated to share, without which this study would not become a reality.

I also owe a great deal of thanks to Prof. Dr. Gürbüz ATAGÜNDÜZ and Prof. Dr. Ali GÜNGÖR, I have worked together with throughout the period of this exciting and wonderful study, for sharing their experience with me and for their never ending technical and personal support.

I would like to take this opportunity to express my gratitude to Prof. Dr. Oktay PASHAEV and Assist. Prof. Dr. Gülden GÖKÇEN for agreeing to be in my thesis defense committee.

I also would like to take this opportunity to thank Prof. Dr. Rasim ALİZADE, Assist. Prof. Dr. Sami SÖZÜER and Assist. Prof. Dr. Salih OKUR for their advices.

I sincerely thank my wife, my parents and colleagues for their support and encouragement.

ABSTRACT

In this study astronomical formulas that are necessary for the mechanical structure of a line focused horizontal receiver-solar thermal power plant are examined. The subjected Power Plant is designed with “Linear Fresnel Reflectors”.

The astronomic formulas are developed to focus the sunrays on a receiver continuously with the single axis orientation of multiple planar reflectors. Rotation axis of the planar reflectors are placed North / South direction. By means of this study it is possible to determine the exact position of the sunrays on the receiver that is reflected from the planar reflectors. Both conditions for the horizontal and inclined placement of the power plant are studied separately. Rotation angles are used by evaluating the formulas.

Considering changing sun position, it is shown that changes in the rotation angle for all of the planar reflectors are equal for continuous focusing. By means of this once the system is adjusted it can be controlled with a single motor for entire year.

With the help of the equations evaluated during the study a small model is projected. For scaling the model the parabola is chosen from the Fresnel design principle. Then the reflector amount, reflector widths and distance between their rotation axes have been determined. Finally the measurement of the model is redesigned to make it possible for the production.

A method is advised for calculating the extraterrestrial solar radiation amount absorbed on the system. And this method is executed for the projected model.

ÖZET

Bu çalışmada “çizgisel odaklayıcı termal güneş enerjisi santralinin” mekanik olarak çalışması için gerekli olan astronomik formüller incelenmiştir. Bahsi geçen santral “Doğrusal Fresnel Yansıtıcıları” kullanılarak dizayn edilmiştir. Dönme eksenleri kuzey-güney doğrultusunda bulunan çok sayıdaki düzlemsel yansıtıcının tek eksenli oryantasyonu ile güneş ışınlarının gün içinde sürekli olarak bir toplayıcıda odaklanmasını sağlayacak formüller geliştirilmiştir. Böylece yansıtıcıdan gelen güneş ışınlarının toplayıcı üzerindeki kesin pozisyonunu belirlemek de mümkün olmuştur. Santralin yatay veya eğimli düzlemde olması durumları ayrı ayrı incelenmiştir. Formüllerin çıkarılmasında “Dönüş Denklemleri”nden yararlanılmıştır.

Odaklamanın sürekli olması için, değişen güneş pozisyonuna göre, yansıtıcıların dönüş açılarındaki değişim miktarının eş olması gerektiği gösterilmiştir. Bu duruma göre, bir kez kalibre edilen sistemin tek bir motor ile bütün bir yıl boyunca kontrol edilebileceği görülmüştür.

Çalışma kapsamında, geliştirilen formüllerden yararlanarak bir maket projelendirilmiştir. Maketin ölçülendirilmesinde, fresnel tasarımı esasına göre taklit edilecek parabol seçilmiş ve daha sonra, yansıtıcı adedi, genişlikleri, dönme eksenleri arası uzaklıkları belirlenmiştir. Belirlenen yapısal ölçüler üretime imkan verecek şekilde tekrar düzenlenmiştir.

Çok sayıda düzlemsel yansıtıcı ve bir adet receiver den oluşan sistemde toplanabilecek ekstraterrestrial güneş radyasyonunu hesaplamak için bir yöntem önerilmiştir. Önerilen yöntem projelendirilen maket için uygulanmıştır.

TABLE OF CONTENTS

LIST OF FIGURES.....	x
LIST OF TABLES.....	xiii
CHAPTER 1. INTRODUCTION.....	1
CHAPTER 2. SOLAR CALCULATION.....	6
2.1. Introduction.....	6
2.2. Parameters.....	7
2.2.1. Latitude - Longitude.....	7
2.2.2. Time Zone.....	7
2.2.3. Daylight Saving.....	7
2.2.4. Time Argument.....	8
2.2.5. Equation of Time.....	9
2.2.6. Local Solar Time.....	10
2.2.7. Hour Angle.....	10
2.3. Development of Equation.....	11
2.3.1. Aim.....	11
2.3.2. Method for Calculation.....	12
2.3.3. Rotation Angles.....	12
2.3.4. Rotation Matrices.....	12
2.3.4.1. 2D Analogy.....	13
2.3.4.2. Rotation About X Axis.....	14
2.3.4.3. Rotation About Y Axis.....	15
2.3.4.4. Rotation About Z Axis.....	16
2.3.5. Assumptions.....	17
2.3.5.1. Day Angle.....	18
2.3.6. Modeling Sun-Earth Relation	18
2.3.6.1. First Coordinate System KS_0.....	19
2.3.6.2. Rotation #1.....	20
2.3.6.3. Rotation #2.....	22

2.3.6.4. Rotation #3.....	23
2.3.6.5. Rotation #4.....	25
2.3.6.6. Rotation #5.....	25
2.3.6.7. Rotation #6.....	26
2.3.6.8. Final Coordinate System KS_6.....	27
2.3.7. Matrix Multiplication.....	29
2.3.8. Matrix Representation of Reflection.....	32
2.3.9. Defining the Reflected Solar Beam.....	32
2.3.9.1. Z Component.....	35
2.3.9.2. X and Y Components.....	36
2.3.10. ψ Angle.....	38
2.3.11. Simplifying the Calculations.....	41
2.3.12. Possible Reflector Orientation for a more Efficient System...	48
2.3.13. Chapter 2 Summary.....	50
CHAPTER 3. MULTI REFLECTOR SYSTEM.....	63
3.1. Introduction.....	63
3.2. Relative Movement of Reflectors.....	64
3.3. Fresnel Reflectors.....	65
3.3.1. Parabola Properties.....	65
3.3.2. Simulation of a Parabola.....	67
3.4. Model.....	69
3.4.1. Limitations.....	70
3.4.2. Line Equation for Reflected Beam.....	70
3.4.3. Tangent of Parabola.....	71
3.4.4. Translating to the Horizontal Plane.....	71
3.4.5. Geometry of all the Reflectors.....	72
3.4.6. Model Geometry.....	73
3.5. Chapter 3 Summary.....	75

CHAPTER 4 . SOLAR ENERGY COLLECTION.....	79
4.1. Introduction.....	79
4.2. Extraterrestrial Solar Radiation.....	80
4.3. Solar Incident Angle.....	81
4.3.1. Solar Incident Angle for North South Oriented Plane.....	82
4.4. Extraterrestrial Solar Radiation for the Inclined Plane.....	83
4.5. Solar Energy Collection for Horizontal System built with North South Oriented (Inclined) Planes.....	84
4.5.1. Introduction.....	84
4.5.2. 1 Reflector - 1 Receiver System.....	85
4.5.3. 2 Reflector - 1 Receiver System.....	86
4.5.4. 4 Reflector - 1 Receiver System.....	87
4.5.5. 8 Reflector - 1 Receiver System.....	88
4.5.6. 16 Reflector - 1 Receiver System.....	89
4.5.7. Comparing the Systems.....	90
4.5.8. Simple Way to Calculate the Total Area.....	92
4.6. "27 Reflector - 1 Receiver System".....	93
4.6.1. Horizontal "27 Reflector - 1 Receiver System".....	93
4.6.2. South Facing "27 Reflector - 1 Receiver System".....	95
 CHAPTER 5. POWER PLANT.....	 97
5.1. Introduction.....	97
5.2. Power Plant.....	98
5.3. Module.....	99
5.3.1. Reflector Quantity, Width, Calibration Angles.....	100
5.3.2. Receiver Width, Length, Position.....	102
5.3.3. Module's South Facing Angle(μ) - Reflector Rotation Angle...	105
5.4. Solar Energy Collection.....	106
 CHAPTER 6. CONCLUSIONS.....	 107

CHAPTER 7. MISCELLANEOUS WORK & RECOMMENDATION FOR THE FUTURE WORKS.....	109
7.1. Domestic Usage.....	109
7.2. New Equations for "Solar Incident Angle for Inclined Plane"	109
7.2.1. New Equation.....	111
7.2.2. Equation in the Literature.....	111
7.2.3. Comparison of two Equations.....	112
7.2.4. Future Work for the Equations.....	112
REFERENCES.....	113

LIST OF FIGURES

<u>Figure</u>	<u>Page</u>
Figure 1.1. Constructed Solar Power Plants.....	1
Figure 2.1. Earth’s orbit around the sun.....	4
Figure 2.2. Latitude and longitude.....	5
Figure 2.3. Equation of time in a year.....	7
Figure 2.4. 1 Reflector - 1 Receiver Pair.....	9
Figure 2.5. Rotated Reflector	9
Figure 2.6. 2D Rotation.....	11
Figure 2.7. Rotation About X Axis.....	12
Figure 2.8. Rotation About Y Axis.....	13
Figure 2.9. Rotation About Z Axis.....	14
Figure 2.10. Day Angle.....	16
Figure 2.11. Reference Position.....	17
Figure 2.12. Rotation #1 (Rotation of KS_0)	18
Figure 2.13. Position after Rotation #1 (View #1)	19
Figure 2.14. Position after Rotation #1 (View #2)	19
Figure 2.15. Rotation #2 (Rotation of KS_1)	20
Figure 2.16. Rotation #3 (Rotation of KS_2)	21
Figure 2.17. Rotation #4 (Rotation of KS_3)	22
Figure 2.18. Rotation #5 (Rotation of KS_4)	23
Figure 2.19. KS_5.....	24
Figure 2.20. KS_5.....	24
Figure 2.21. Rotation #6 (Rotation of KS_5)	25
Figure 2.22. β Angle.....	25
Figure 2.23. All the Rotations.....	26
Figure 2.24. x and y components.....	35
Figure 2.25. 2D Graphic for Horizontal Reflector-Receiver Pair.....	50
Figure 2.26. 3D Graphic for Horizontal Reflector-Receiver Pair.....	50
Figure 2.27. 2D Graphic for South Facing (15.01°) Reflector-Receiver Pair.....	51
Figure 2.28. 3D Graphic for South Facing (15.01°) Reflector-Receiver Pair.....	51
Figure 2.29. 2D Graphic for South Facing (23.45°) Reflector-Receiver Pair.....	52

<u>Figure</u>	<u>Page</u>
Figure 2.30. 3D Graphic for South Facing (23.45°) Reflector-Receiver Pair.....	52
Figure 2.31. 2D Graphic for South Facing (38.46°) Reflector-Receiver Pair.....	53
Figure 2.32. 3D Graphic for South Facing (38.46°) Reflector-Receiver Pair.....	53
Figure 2.33. 2D Graphic for South Facing (61.91°) Reflector-Receiver Pair.....	54
Figure 2.34. 3D Graphic for South Facing (61.91°) Reflector-Receiver Pair.....	54
Figure 2.35. v / h Ratio.....	55
Figure 2.36. v / h Ratio Graphics for Horizontal Reflector-Receiver Pair.....	56
Figure 2.37. v / h Ratio Graphics for South Facing (15.01°) Reflector-Receiver Pair....	57
Figure 2.38. v / h Ratio Graphics for South Facing (23.45°) Reflector-Receiver Pair....	58
Figure 2.39. v / h Ratio Graphics for South Facing (38.46°) Reflector-Receiver Pair....	59
Figure 2.40. v / h Ratio Graphics for South Facing (61.91°) Reflector-Receiver Pair....	60
Figure 3.1. Multi Reflector System.....	61
Figure 3.2. Relative Movement of Reflectors.....	62
Figure 3.3. Focal Point of Parabola.....	63
Figure 3.4. Parabolic Concentrator.....	66
Figure 3.5. Parabolic Concentrator as a series of Flat Segments.....	66
Figure 3.6. Fresnel Ferlectors.....	66
Figure 3.7. $y = x^2/4000$ Parabola.....	67
Figure 3.8. Line Equation for Reflected Beam.....	68
Figure 3.9. $y = x^2 / 4000$ Parabola / SOLAR TIME ($\omega = 0$).....	73
Figure 3.10. Simulation of $y = x^2 / 4000$ Parabola / SOLAR NOON ($\omega = 0$).....	74
Figure 3.11. Simulation of $y = x^2 / 4000$ Parabola / SOLAR TIME ($\omega = 30$).....	75
Figure 3.12. Simulation of $y = x^2 / 4000$ Parabola / SOLAR TIME ($\omega = 60$).....	76
Figure 4.1. Extraterrestrial Solar Radiation.....	78
Figure 4.2. Extraterrestrial Solar Radiation for Inclined Plane.....	81
Figure 4.3. "1Reflector - 1 Receiver" System.....	83
Figure 4.4. "2Reflector - 1 Receiver" System.....	84
Figure 4.5. "4 Reflector - 1 Receiver" System.....	85
Figure 4.6. "8 Reflector - 1 Receiver" System.....	86
Figure 4.7. "16 Reflector - 1 Receiver" System.....	87
Figure 4.8. Aperture - Number of Reflectors.....	88
Figure 4.9. Concentration Ratio - Number of Reflectors.....	88

<u>Figure</u>	<u>Page</u>
Figure 4.10. Concentration Ratio - Hour Angle.....	89
Figure 4.11. Aperture - Hour Angle.....	89
Figure 4.12. Aperture/Concentration Ratio - Hour Angle.....	89
Figure 4.13. Virtual Line.....	90
Figure 4.14. Horizontal "27 Reflector - 1 Receiver System".....	91
Figure 4.15. Inclined Virtual Plane.....	91
Figure 4.16. Horizontal Virtual Plane.....	91
Figure 4.17. South Facing "27 Reflector - 1 Receiver System".....	92
Figure 4.18. Extraterrestrial Solar Radiation in İzmir.....	93
Figure 4.19. Total Annual Extraterrestrial Solar Radiation in İzmir.....	94
Figure 5.1. Simulation of Power Plant.....	96
Figure 5.2. Overall Lengths of Module.....	97
Figure 5.3. Reflector Numbers.....	98
Figure 5.4. Fixed Receiver.....	101
Figure 5.5. Movable Receiver.....	101
Figure 5.6. Position of "Movable Receiver" on January #1.....	102
Figure 5.6. Position of "Movable Receiver" on August #20.....	102
Figure 7.1. Simplified Drawing in the Literature.....	110
Figure 7.2. Actual Drawing.....	110

LIST OF TABLES

<u>Figure</u>	<u>Page</u>
Table 2.1. Days to Beginning of Month (Nm).....	8
Table 3.1. Geometry of all Reflectors.....	72
Table 3.2. Model Geometry.....	73
Table 3.3. Calibration Angles.....	74
Table 4.1. Properties of Examined "Reflector-Receiver" Systems.....	84
Table 5.1. Calibration Angle of Reflectors.....	101

CHAPTER 1

INTRODUCTION

Today interest in renewable energy sources increases. The most suitable energy source for our region is obviously solar energy. Although solar energy is usually used for common house use it is also suitable for production of electricity energy. Producing electricity with solar energy is done with either Photovoltaic Cells or with Concentrating Solar Thermal Systems (high volume productions).

Concentrating solar power plants produce electric power by converting the sun's energy into high-temperature heat using various mirror configurations. The heat is then channeled through a conventional generator. The plants consist of two parts: one that collects solar energy and converts it to heat, and another that converts heat energy to electricity.

Concentrating solar power systems can be sized for village power (10 kilowatts) or grid-connected applications (up to 100 megawatts). Some systems use thermal storage during cloudy periods or at night. Others can be combined with natural gas and the resulting hybrid power plants provide high-value, dispatch able power. These attributes, along with world record solar-to-electric conversion efficiencies, make concentrating solar power an attractive renewable energy option in the Southwest and other sunbelt regions worldwide. There are three CSP technologies being promoted internationally.

- Parabolic Trough Systems
- Power Tower Systems
- Parabolic Dish Systems

For each of these, there exists various design variations or different configurations. The amount of power generated by a concentrating solar power plant depends on the amount of direct sunlight. Like concentrating photovoltaic concentrators, these technologies use only direct-beam sunlight, rather than diffuse solar radiation.

By "Parabolic Trough Systems" (Figure 1.1.), the sun's energy is concentrated by parabolically curved, trough-shaped reflectors onto a receiver pipe running along the inside of the curved surface. This energy heats oil flowing through the pipe, and the heat energy is then used to generate electricity in a conventional steam generator.



Figure 1.1. Trough Collector Field in Kramer Junction, California.

(Source : <http://www.nrel.gov/data/pix>)

A collector field comprises many troughs in parallel rows aligned on a north-south axis. This configuration enables the single-axis troughs to track the sun from east to west during the day to ensure that the sun is continuously focused on the receiver pipes. Individual trough systems currently can generate about 80 megawatts of electricity.

By "Power Tower Systems" (Figure 1.2.), a power tower converts sunshine into clean electricity for the world's electricity grids. The technology utilizes many large, sun-tracking mirrors (heliostats) to focus sunlight on a receiver at the top of a tower. A heat transfer fluid heated in the receiver is used to generate steam, which, in turn, is used in a conventional turbine-generator to produce electricity.

Early power towers (such as the Solar One plant) utilized steam as the heat transfer fluid; current US designs utilize molten nitrate salt because of its superior heat transfer and energy storage capabilities. Current European designs use air as heat transfer medium because of its high temperature and its good hand ability. Individual commercial plants will be sized to produce anywhere from 50 to 200 MW of electricity.



Figure 1.2. Solar Tower Test Site CESA - 1 at Plataforma Solar, PSA, Almería , Spain.

(Source : <http://www.dlr.de/TT/solartherm/solargasturbine/pictures>)

"Parabolic Dish Systems" (Figure 1.3.) consist of a parabolic-shaped point focus concentrator in the form of a dish that reflects solar radiation onto a receiver mounted at the focal point. These concentrators are mounted on a structure with a two-axis tracking system to follow the sun. The collected heat is typically utilized directly by a heat engine mounted on the receiver moving with the dish structure.



Figure 1.3. Paraboloidal dish, Eurodish

(Source: <http://www.dlr.de/PSA/central/stirling/eurodish/index.html>)

Another option is the simulation of parabolic troughs according to the principle of "Fresnel Design", which is the subject of this study. Main difference of this design is the way of focusing the solar beams. The idea is to assume a parabolic trough which is composed of unlimited number flat planes (Figure 1.4.). Reducing number of planes that composes the trough decreases the concentration value while increasing the simplicity of the geometrical form.

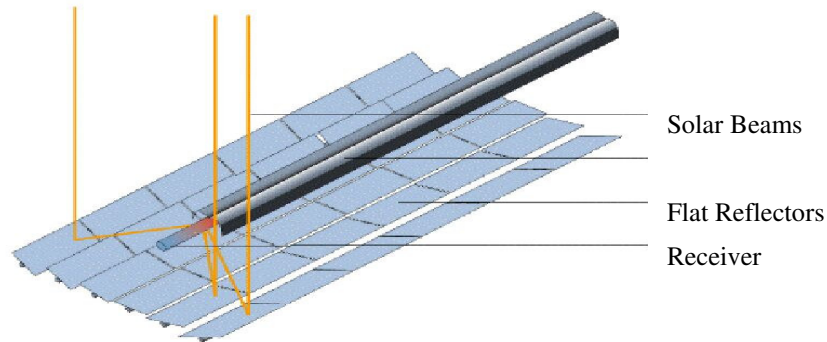

Figure 1.4. Fresnel Design Principle

By redesigning these limited numbered planes production and maintenance cost can be reduced and much more stable construction can be obtained (against winds etc.)

The most important advantages are;

- flat (inexpensive) reflectors
- simple (inexpensive) control mechanism.

Subjected reflector design is controlled differently from the "Parabolic Trough", "Parabolic Dish" or "Photovoltaic Cell" systems. As known mentioned systems try to obtain vertical position to sun. But in the subjected "Fresnel Design" system every reflector must reflect the solar beams to a single receiver. This necessity requires mechanical stability. 1-degree fault means that solar beams don't contact the receiver thus the system doesn't work.

Aim of this study is to project an inexpensive solar collector to build small or large scale "solar power plants". Fresnel design is chosen because of its low cost of planar reflectors, possible simple tracking mechanism and practicability for large/small scale power plants. Tracking mechanism is the beginning point for such a study. There are different alternatives for the tracking mechanism like hydraulically/electrically forced and different control alternatives like open loop/closed loop based.

This study includes 7 chapters. In chapter 2 astronomical relations between sun and earth are examined. Some astronomical equations are developed by using the "spherical trigonometry" and "rotation angles". All the steps of the calculations are described clearly by giving the new original drawings. Some concepts in the solar calculation literature like "declination angle" or "celestial sphere" are not used.

Because position of the sun can be calculated open loop control is preferred. In the open loop control system sun position is calculated with the help of the developed

astronomical equations and reflectors are controlled. Close loop controls that the sensors follow the maximum light were not preferred. In this chapter geometrical parameters required for the calculations are given. To advance in the calculations a model with single reflector and a receiver right above the reflector is defined.

In this chapter, "**direct solar beam**" and "**reflected solar beam**" vectors are defined respect to the reflector and the receiver for any time of the year. Also equations for calculating the exact targeting position (on the receiver) of the reflected solar beams are developed.

Orientation of the reflectors is made in single axis. Continuously orientation in two axes is not preferred. But to increase the efficiency inclined placement of the system is studied. To reduce the heat losses, **receiver length and position is optimized** considering complete year.

In chapter 3, study goes forward. The **multi reflector model** is studied and calibration of the reflectors that has parallel rotation axis is examined. A model is designed to describe the structural features of all elements in the system.

In Chapter 4 **collecting (absorbing) extraterrestrial solar energy** is studied. Instead of calculating amount of energy reflected from each separate reflector and adding them to calculate the total energy, the energy amount collected on whole of the system is calculated. This calculation method is repeated for south facing system and calculations are made for İzmir.

In Chapter 5, simulation of a power plant is made. The power plant is formed from multiple modules placed facing south with an angle equal to the latitude. Every module is composed of 27 reflectors and a receiver as mentioned in the previous chapter. Controlling reflectors with **a single motor that is rotating with constant rotation speed is proper for focusing the sunbeams to the receiver**. To collect all of the sunbeams reflected, the receivers should be longer than the reflectors. Over lengthening of the receiver is prevented because this would create heat loss.

In Chapter 6, the "conclusions" are presented.

And finally in Chapter 7, some "recommendations for the future work" are presented. Also by using the method of calculation in chapter 2, a new developed equation for the "solar incident angle for inclined planes" is given. And the differences of the equation from the one in the literature are described.

CHAPTER 2

SOLAR CALCULATION

2.1. Introduction

The earth revolves around the Sun in an elliptical orbit. It takes 365.2564 days for the earth to travel around the sun and 23.9345 hours for the earth to complete a full rotation.

The earth's rotation axis is always inclined at an angle of 23.45° from the ecliptic axis, which is normal to the ecliptic plane, shown in (Figure 2.1.). The seasons are due to the fact that the earth's axis is inclined with respect to the ecliptic plane. Sunrays strike the earth's Northern Hemisphere more directly near aphelion, causing summer in that hemisphere during that portion of the year. At the same time, sunrays strike the earth's Southern Hemisphere more obliquely, causing winter there.

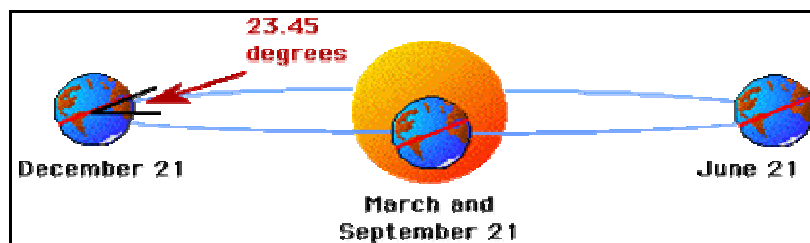

Figure 2.1 Earth's orbit around the sun

As shown in (Figure 2.1.), at the winter solstice (about December 21), the North Pole is inclined 23.45° away from the rotation axis of the sun; thus all points on the earth's surface north of the Arctic Circle are in complete darkness, whereas all points South of the Antarctic Circle receive continuous sunlight. At the summer solstice (about June 21), the reverse is true. At the vernal and autumn equinoxes (about March 21 and September 21, respectively), the North and South Poles are equidistant from the sun; thus all points on the earth's surface have 12 hours of daylight and 12 hours of darkness.

2.2. Parameters

2.2.1. Latitude ϕ and Longitude λ

Latitude ϕ is a scale used to measure one's location on the earth, north or south of the equator. Latitude values for points south of the equator are always negative, and values for points north of the equator are always positive as shown in (Figure- 2.2.)

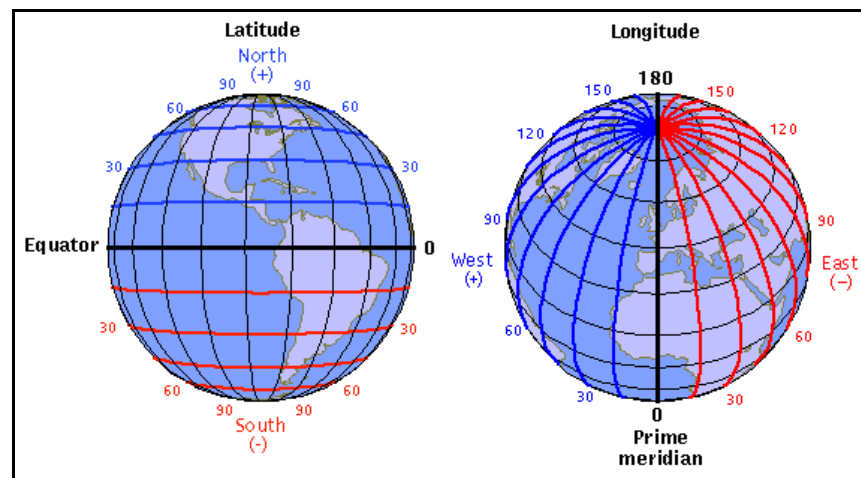

Figure 2.2. Latitude and longitude

The longitude is a scale used to measure one's location on the earth, east or west of the Greenwich Meridian. The Greenwich Meridian is 0° longitude. Longitude values for points east of the Greenwich Meridian are always negative, while points west of the Greenwich Meridian are always positive as shown in (Figure- 2.2.)

2.2.2. Time Zone

There are 24 standard time zones, each approximately occurring at 15° intervals of longitude. One must offset the Universal Time (UT) by the number of hours west, or east of the Greenwich Meridian. Going west, one must subtract the number of hours from GMT (Greenwich Mean Time). Going east, one may add hours to GMT.

2.2.3. Daylight Saving DS

Daylight saving time DS is observed in most locations around the world by setting clocks ahead one hour during the summer.

2.2.4. Time Argument

To avoid calculation complications in calendar dates, astronomers number days in a continuous sequence called the Julian Date (JD). In the Julian calendar, most years have 365 days, with an extra day every fourth year (called a leap-year), thus averaging 365.25 days to a year.(Table 2.1.)

Table- 2.1. Days to beginning of month (Nm). i is calendar day.

Month	Normal year	Leap year
January	$0 + i$	$0 + i$
February	$31 + i$	$31 + i$
March	$59 + i$	$60 + i$
April	$90 + i$	$91 + 1$
May	$120 + i$	$121 + i$
Jun	$151 + i$	$152 + i$
July	$181 + i$	$182 + i$
August	$212 + i$	$213 + i$
September	$243 + i$	$244 + i$
October	$273 + i$	$274 + i$
November	$304 + i$	$305 + i$
December	$334 + i$	$335 + i$

2.2.5. Equation of Time EoT

As the earth moves around the sun, solar time changes slightly with respect to Local Standard Time (LST). Such time difference is called the equation of time. As shown in (Figure- 2.3.), equation of time does not have the same value for various months or days.

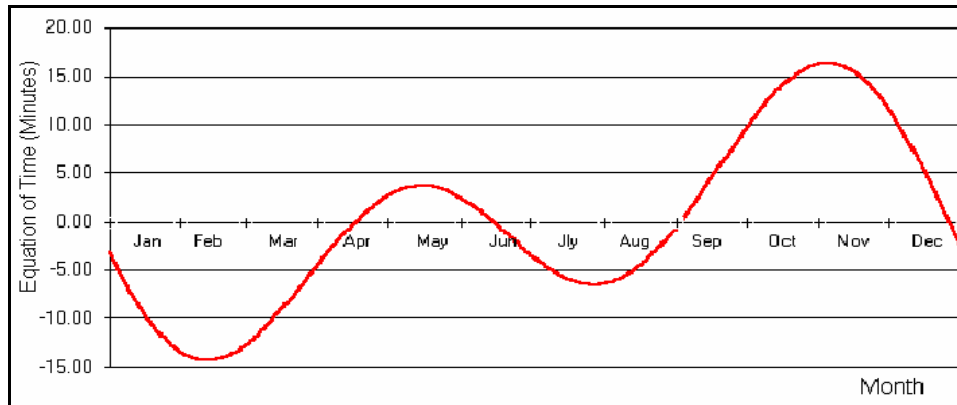

Figure- 2.3. Equation of time in a year

EoT is measured in degree, and may be converted to minutes by multiplying 4 (1 degree equals to 4 minutes of time). An approximate formula for EoT in minutes is,

$$\text{EoT} = 9,87 \cdot \sin(2B) - 7,5 \cdot \cos(B) - 1,5 \cdot \sin(B) \quad (2.1.)$$

$$B = 360 \cdot (n - 81) / 364 \quad (2.2.)$$

n : Number of the Days

2.2.6. Local Solar Time

Local Solar Time (LSoT) is the time according to the position of the sun relative to one specific location on the ground. In solar angle calculations, LSoT is found by a conversion from LST. LST is measured with respect to observer's longitude. Three factors are considered in the conversion.

- The relationship between the local standard time zone and the local longitude; longitude correction term ($\text{long}_{\text{standard}} - \text{long}_{\text{local}}$).
- Equation of the time (EoT)
- Daylight saving time (DS)

LSoT is calculated as follows,

$$\text{LSoT} = \text{LST} \pm 4 \cdot (\text{long}_{\text{standard}} - \text{long}_{\text{local}}) + \text{EoT} + \text{DS} \quad (2.3.)$$

It must be noted that, if the local meridian is at east of the GMT, the longitude correction is negative, and at west of the GMT, the longitude correction is positive. A longitude correction term multiplied by 4, since the sun moves 15° in 60 minutes.

2.2.7. Hour Angle (ω)

The hour angle is defined as the number of minutes between the LST and solar noon, when the sun is straight overhead. The hour angle, thus, is zero at local solar noon, where afternoon hours are designated as positive. As the outcome of 360 degrees per 24 hours, each hour is equivalent to 15° of longitude. The hour angle in degrees is,

$$\omega = (\text{LsoT} - 12) \cdot 15^\circ \quad (2.4.)$$

2.3. Development of Equation

2.3.1. Aim

In (Figure 2.4.) a single reflector and a receiver right above the reflector are shown. Both the receiver and the reflector are placed in horizontal plane. Reflector has a rotation axis in north-south direction. As shown in figure, solar beam hits the reflector and reflects bisecting the reflectors normal, without reaching the receiver.

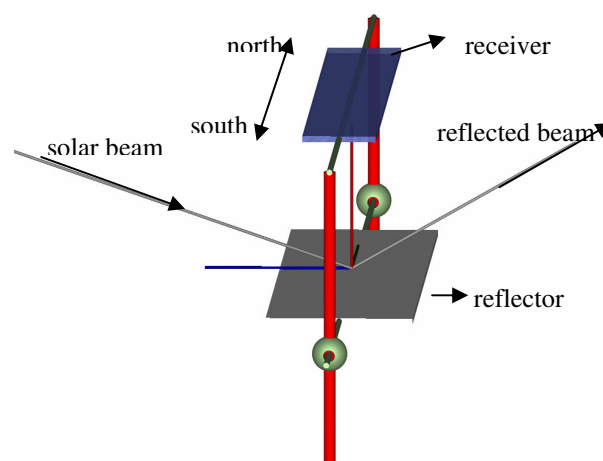

Figure 2.4. 1 Reflector - 1 Receiver Pair

In (Figure 2.5.) reflector is rotated about its rotation axis in the north-south direction with an angle β . In this case, reflected solar beam reaches the receiver.

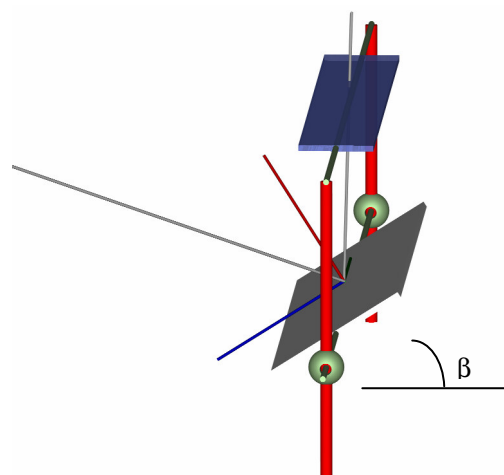

Figure 2.5. Rotated Reflector

The purpose is to express solar beams in vectors for any time of the year. By this way, reflected solar beams are defined and rotation angle shown in (Figure 2.5) is calculated.

2.3.2. Method for Calculation

Cartesian Coordinate System, which is located at a specified position according to sun is rotated with a predefined order. Solar beams are defined according to the final Cartesian Coordinate System. By using the same Cartesian Coordinate System reflector and receiver normals are defined.

Rotation Angles are used for all these rotations.

2.3.3. Rotation Angles

When discussing a rotation, there are two possible conventions: rotation of the axes, and rotation of the object relative to fixed axes.

Rotation angles are useful to describe rotations or relative orientations of orthogonal coordinate systems. All rotations are in a counter-clockwise fashion (right-handed, mathematically positive sense).

The Rotation angles relate two orthogonal coordinate systems having a common origin. The transition from one coordinate system to the other is achieved by a series of two-dimensional rotations. The rotations are performed about coordinate system axes generated by the previous rotation step.

2.3.4. Rotation Matrices

Rotations or transformations from one coordinate system into another are conveniently described by the triplet of Rotation angles. Using the Rotation angles, this three-dimensional problem can be dissected into a sequence of two-dimensional rotations, whereby in each rotation one axis remains invariant.

2.3.4.1. 2D Analogy:

In order to simplify the problem, let us start with a two-dimensional rotation:

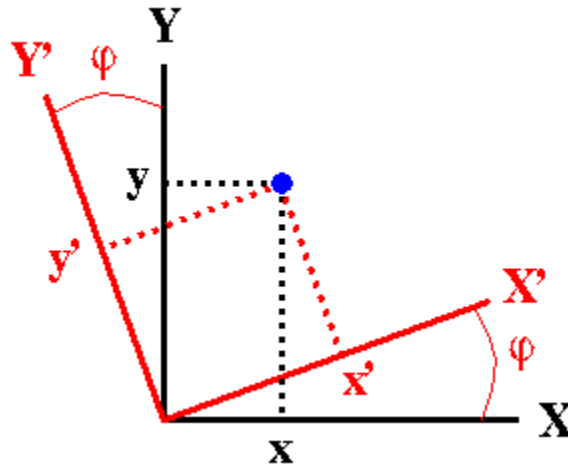

Figure 2.6. 2D Rotation

Suppose the coordinates, (x, y) , of a point in the two-dimensional XY system are known (Figure 2.6.), but we are actually interested in knowing the coordinates of this point in another coordinate system, $X'Y'$, which is related to the XY system by a counter-clockwise rotation by an angle ϕ .

As the figure indicates, the coordinates of the given point in the new coordinate system will be:

$$x' = x \cos \phi + y \sin \phi \quad (2.5.)$$

$$y' = -x \sin \phi + y \cos \phi \quad (2.6.)$$

or, in matrix notation:

$$R_z(\phi) = \begin{vmatrix} \cos \phi & \sin \phi \\ -\sin \phi & \cos \phi \end{vmatrix}$$

2.3.4.2. Rotation About X Axis

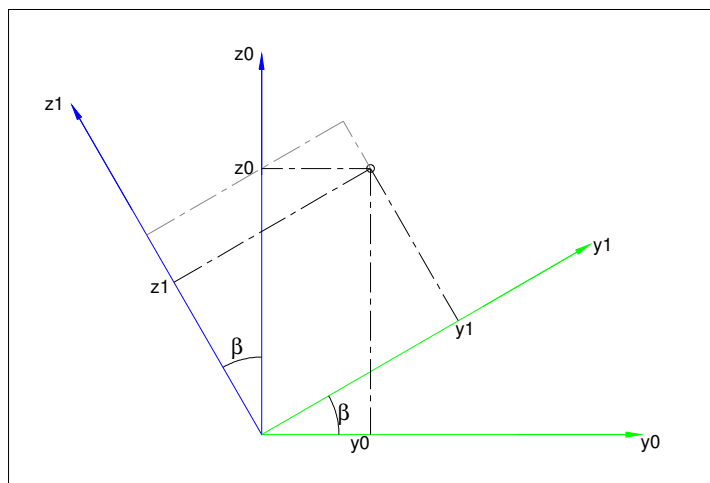
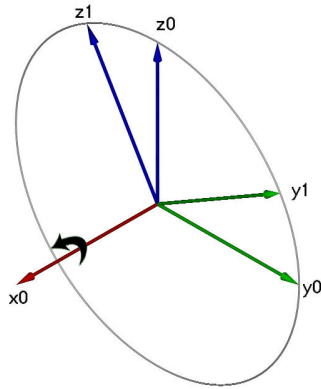

Figure 2.7. Rotation About X Axis

The rotation involves the Rotation angle β . The x_0, y_0, z_0 axis system is rotated about the X axis through an angle β counterclockwise relative to X,Y,Z to give the new system x_1, y_1, z_1 . It is clear from the (Figure 2.7.) that this rotation mixes the coordinates along Y and Z, completely analogous to the two-dimensional rotation described above, while the coordinate along X remains unaffected.

$$x_1 = x_0 \tag{2.7.}$$

$$y_1 = y_0 \cos \beta + z_0 \sin \beta \tag{2.8.}$$

$$z_1 = -y_0 \sin \beta + z_0 \cos \beta \tag{2.9.}$$

The rotation matrix to describe this operation is given by:

$$R_x(\beta) = \begin{vmatrix} 1 & 0 & 0 \\ 0 & \cos \beta & \sin \beta \\ 0 & -\sin \beta & \cos \beta \end{vmatrix}$$

2.3.4.3 Rotation About Y Axis

Rotation About Y axis is shown in (Figure 2.8.).

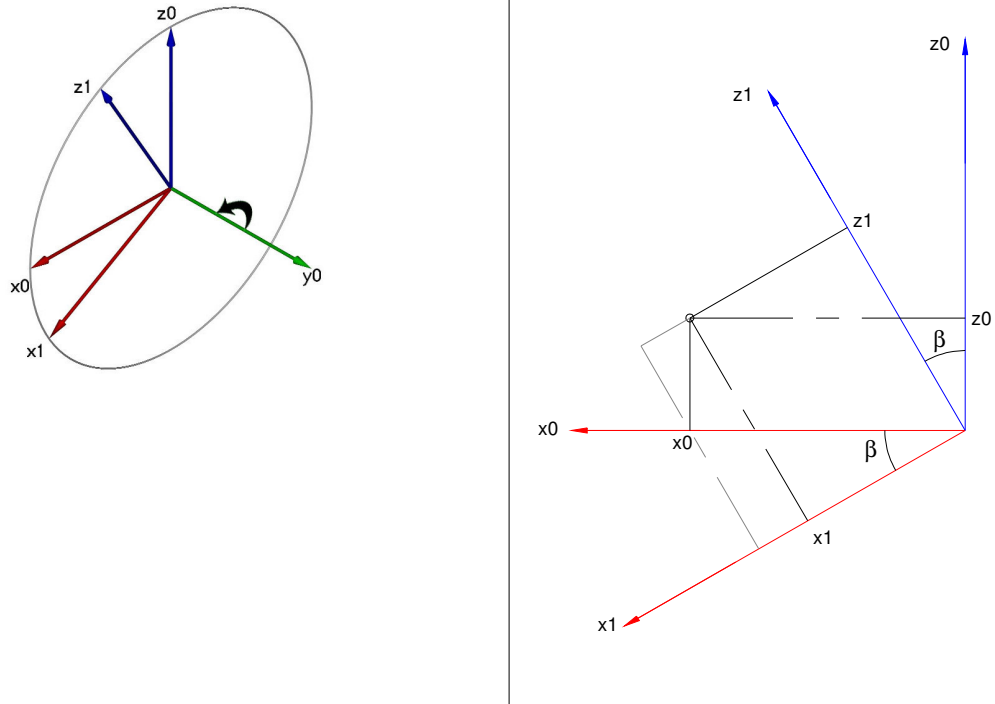

Figure 2.8. Rotation About Y Axis

After this rotation;

$$x_1 = x_0 \cos \beta - z_0 \sin \beta \quad (2.10.)$$

$$y_1 = y_0 \quad (2.11.)$$

$$z_1 = x_0 \sin \beta + z_0 \cos \beta \quad (2.12.)$$

The rotation matrix to describe this operation is given by:

$$R_y(\beta) = \begin{vmatrix} \cos \beta & 0 & -\sin \beta \\ 0 & 1 & 0 \\ \sin \beta & 0 & \cos \beta \end{vmatrix}$$

2.3.4.4. Rotation About Z axis

Rotation About Z axis is shown in (Figure 2.9.).

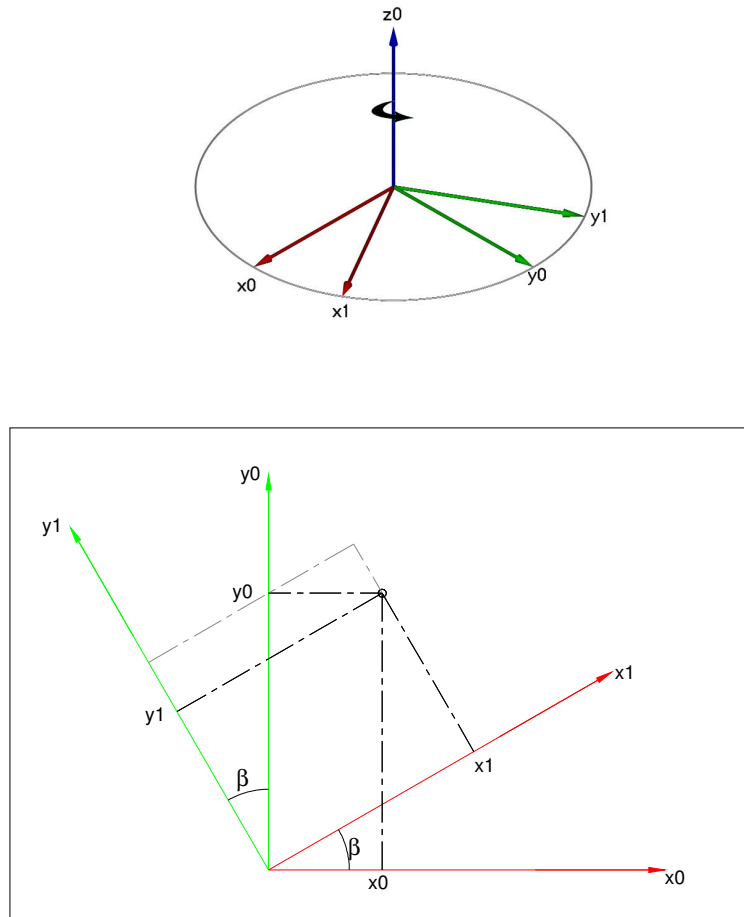

Figure 2.9. Rotation About Z Axis

After this rotation;

$$x_1 = x_0 \cos \beta + y_0 \sin \beta \quad (2.13.)$$

$$y_1 = -x_0 \sin \beta + y_0 \cos \beta \quad (2.14.)$$

$$z_1 = z_0 \quad (2.15.)$$

The rotation matrix to describe this operation is given by:

$$R_z(\beta) = \begin{vmatrix} \cos \beta & \sin \beta & 0 \\ -\sin \beta & \cos \beta & 0 \\ 0 & 0 & 1 \end{vmatrix}$$

2.3.5. Assumptions

1. Shape of the earth is assumed as a sphere.
2. Orbit across the sun is assumed as circular. This assumption is made because the distance between earth and sun changes $\pm 1.7\%$ in entire year.
3. One full spin of earth about its self is assumed as 24 hours.
4. Solar beams reaching to earth are assumed parallel.
5. Altitude of the selected location is ignored.
6. Cartesian coordinates are only rotated. Translation is ignored because earth radius is very small comparing to the distance between earth and sun. KS_0 - KS1 - KS2 - KS3 - KS4 - KS5 are on the center of the earth and KS6 is on the surface. Translation from center to surface of earth, which should be between KS5 and KS6, is ignored.

2.3.5.1. Day Angle (α)

Complete rotation of earth (360 degrees) around the sun is completed in 365 days. So every day earth travels $360/365$ degrees in the orbit. In this case the angle α will be calculated according to a reference day. (Figure 2.10)

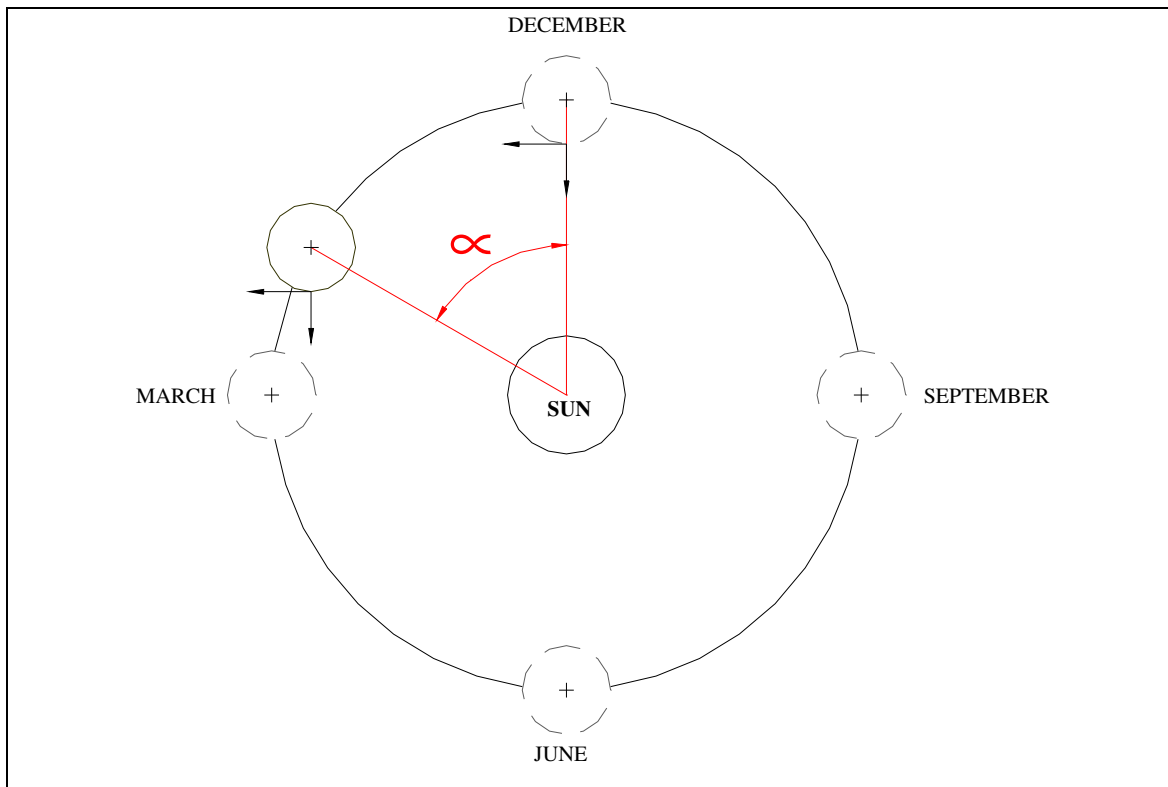

Figure 2.10. Day Angle

2.3.6. Modeling The Sun-Earth Relation

For developing astronomical formulas the case below should be imagined. Coordinate system described below will be rotated in respect of the main axes. Rotation angles and rotation matrices are used at this point.

First Coordinate System is named KS_0. After every rotation a new coordinate system is created and named in order KS_1, KS_2 and so on. The axes of KS_0 is named similarly x_0, y_0, z_0 ; of KS_1 is named x_1, y_1, z_1 etc. And unit vectors are defined $\vec{i}_0, \vec{j}_0, \vec{k}_0$; $\vec{i}_1, \vec{j}_1, \vec{k}_1$ etc.

2.3.6.1. First Coordinate System (KS_0)

The first coordinate system (KS_0) is described as shown in (Figure 2.11.).

1. Earth is not inclined $23,45^\circ$
2. According to solar time it is 12 o'clock (solar noon) at 21st of December.
3. A plane in center of the earth, perpendicular pointing the sun.

Coordinate system KS_0 which has axes x_0 , y_0 , z_0 is placed as its origin is at the center of the earth. Normal of the plane is pointing the sun and its direction is in x_0 . In this case solar beams can be defined in the direction of $-x_0$. And the vector of solar beam \vec{G} described in KS_0 is;

$$\vec{G} = -\vec{i}$$

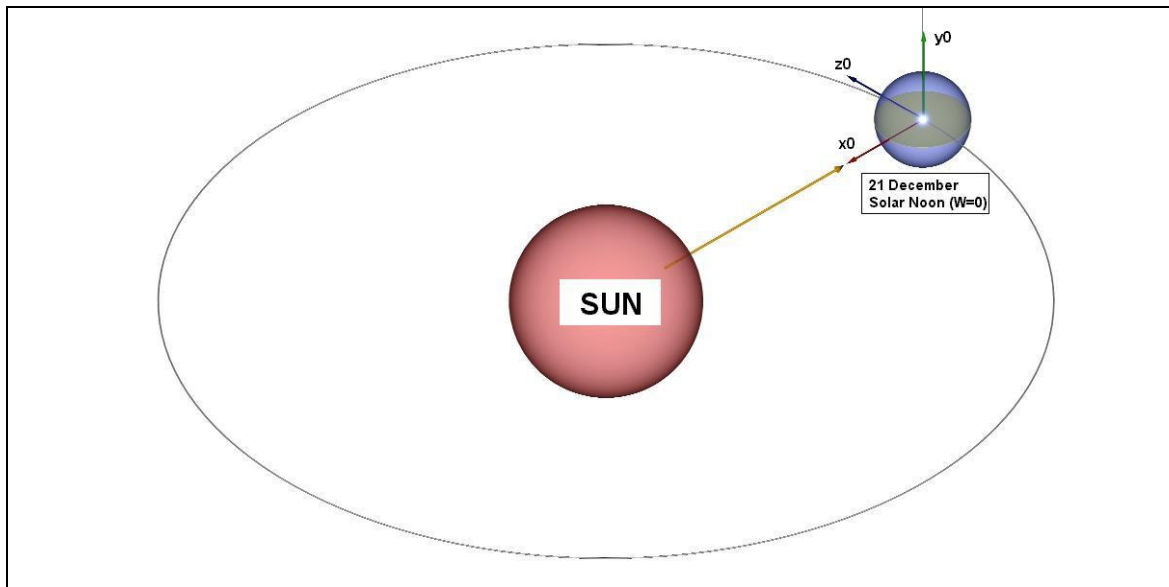

Figure 2.11. Reference Position

2.3.6.2 Rotation #1

KS_0 , is rotated with an α angle about the y_0 axis shown in (Figure 2.12). By this way KS_1 is created. Rotation angle α is calculated by determining the number of days from the 21st of December.

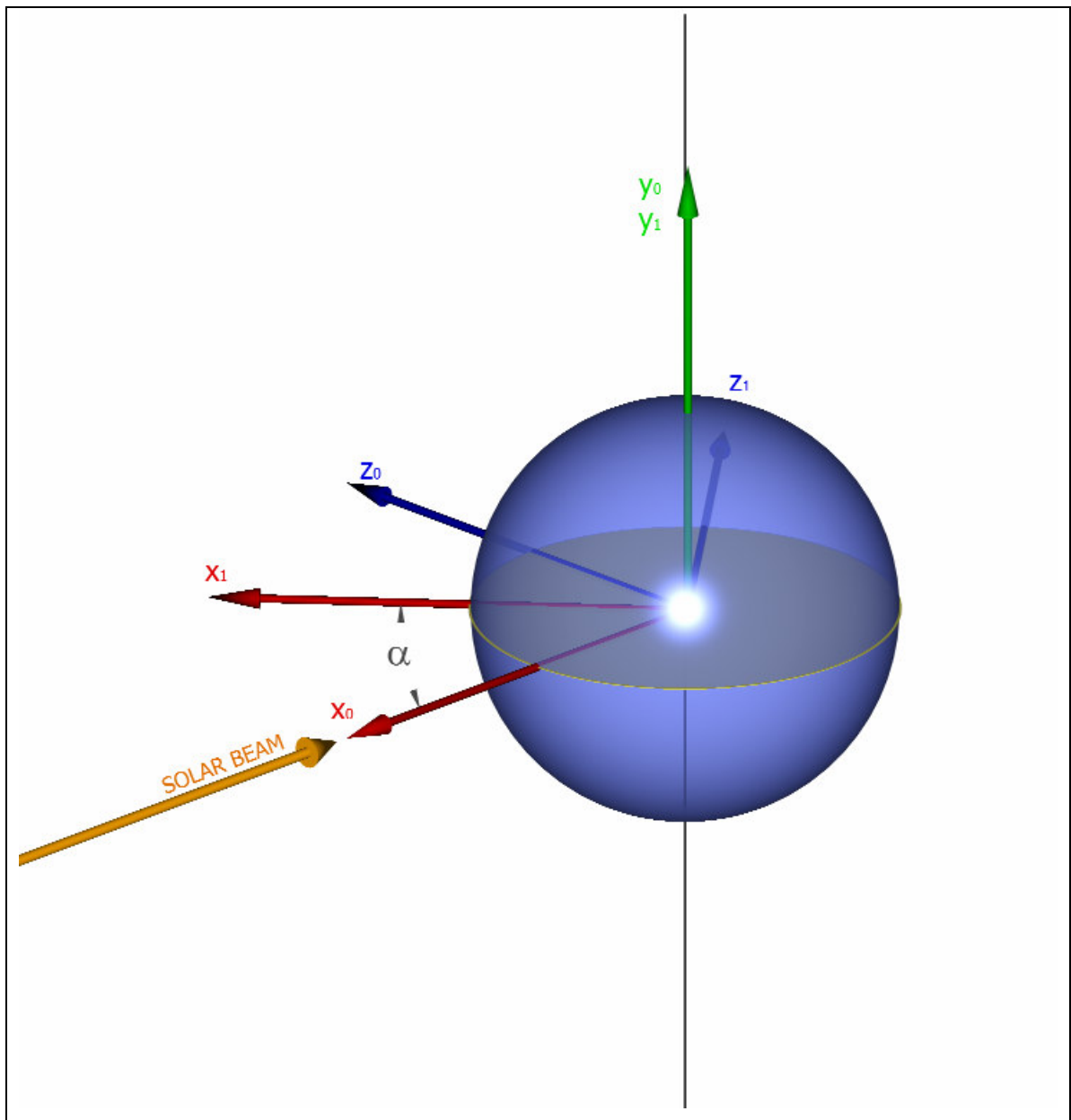

Figure 2.12. Rotation #1 (Rotation of KS_0)

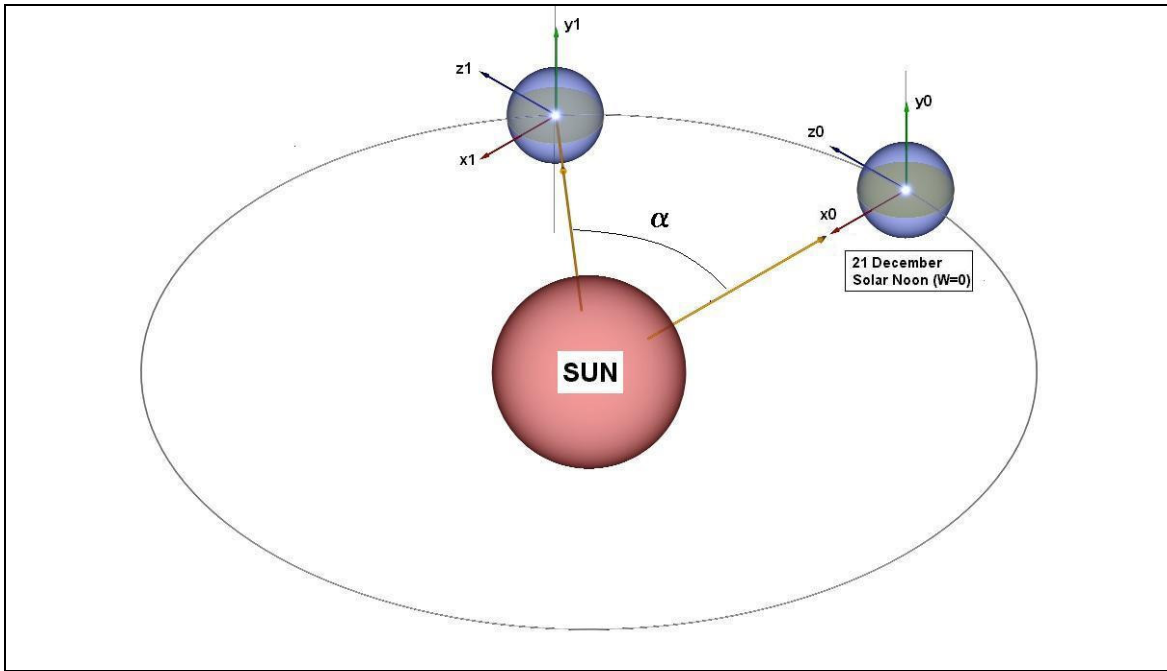

Figure 2.13. Position after Rotation #1 (View #1)

Position in (Figure 2.13.) is shown at a different perspective in (Figure 2.14.).

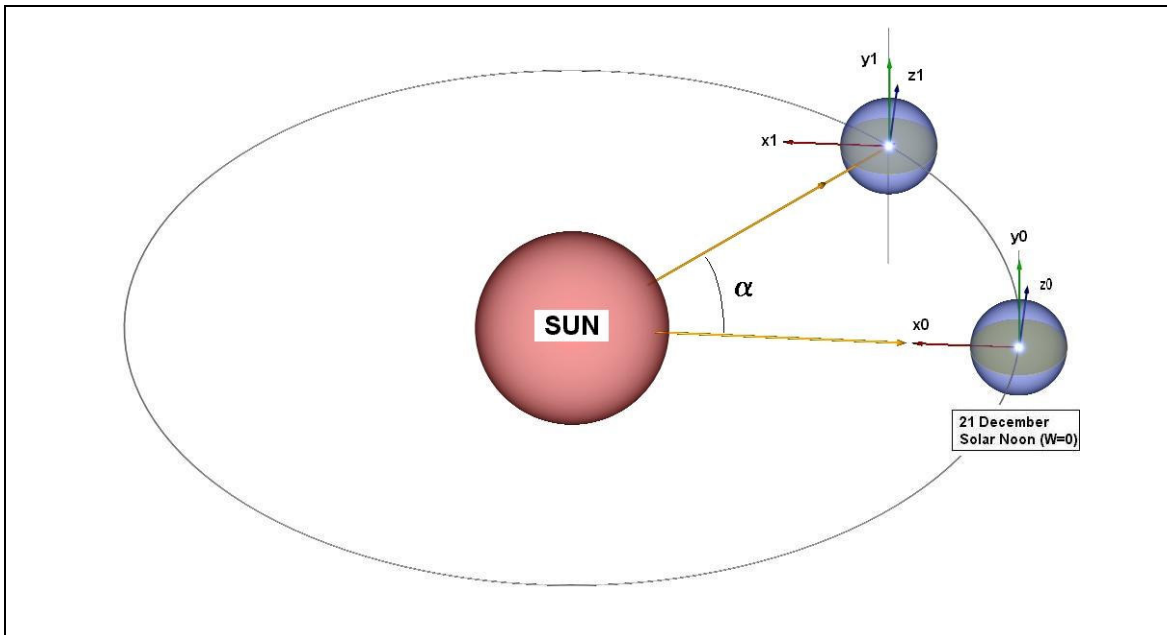

Figure 2.14. Position after Rotation #1 (View #2)

2.3.6.3. Rotation #2

KS_1 is rotated $23,45^\circ$ about the z_1 axis. KS_2 is created. (Figure 2.15.)

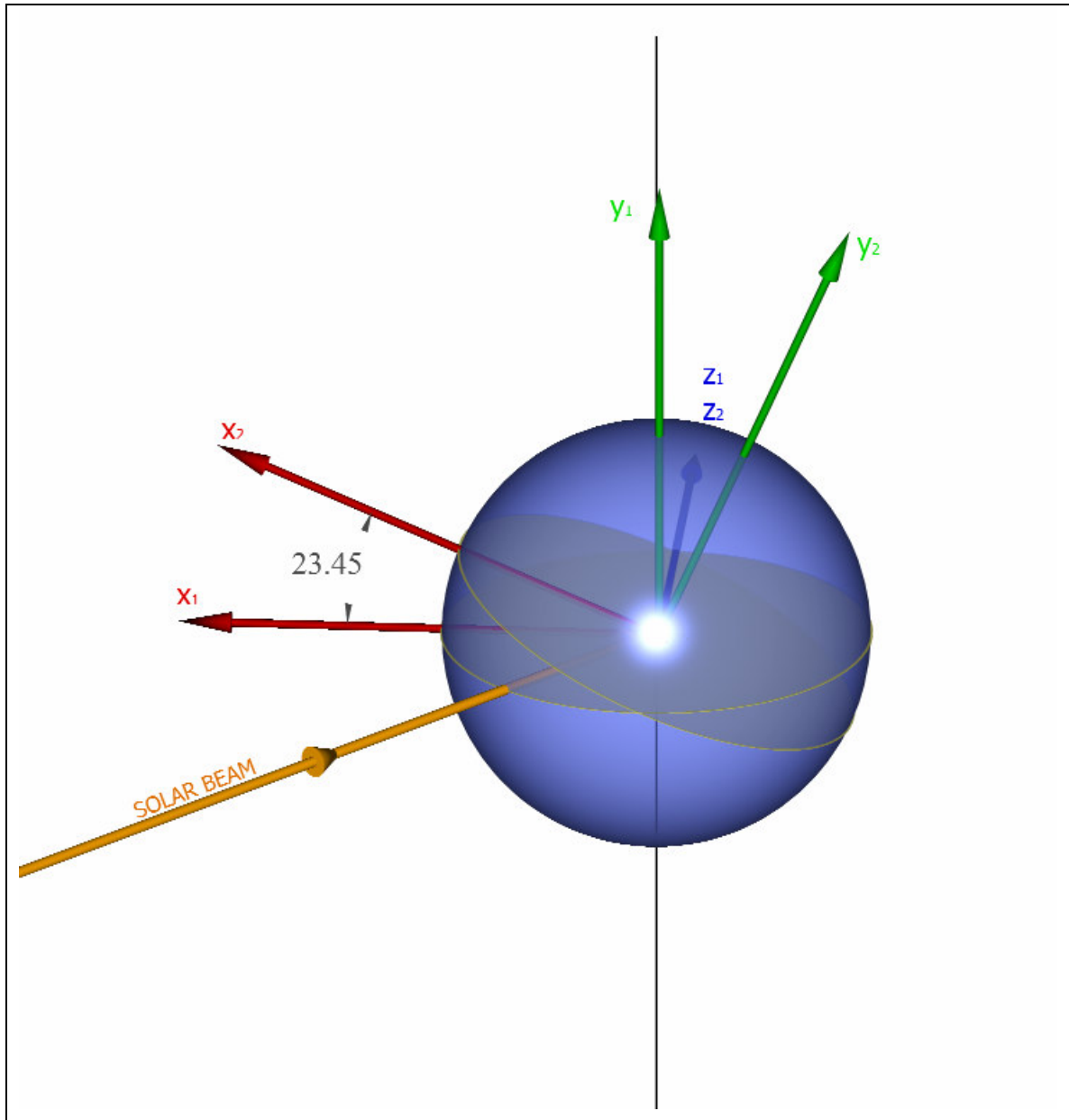

Figure 2.15. Rotation #2 (Rotation of KS_1)

2.3.6.4. Rotation #3

KS_2 is rotated with ψ angle about the y_2 axis (Figure 2.16.). This way KS_3 is obtained. ψ angle should be calculated and its purpose is to intersect the reflector plane with the solar noon. This will be subjected later in detail.

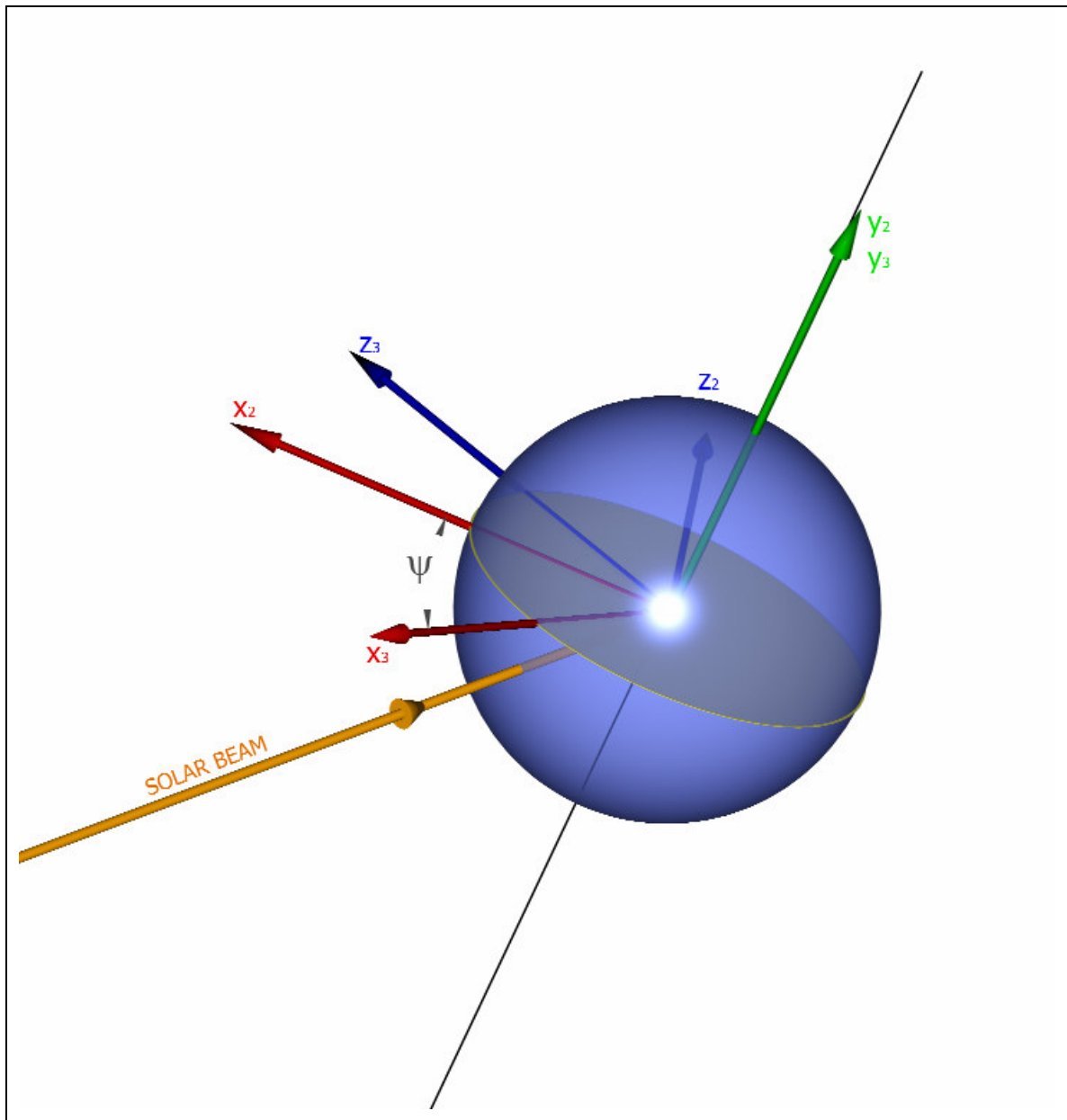

Figure 2.16. Rotation #3 (Rotation of KS_2)

2.3.6.5. Rotation #4

KS_3 is rotated with ω angle about the y_3 axis. (Figure 2.17.) ω angle is named as hour angle. It states the difference to the solar noon. Before the solar noon ω is valued (-), after solar noon it is valued (+).

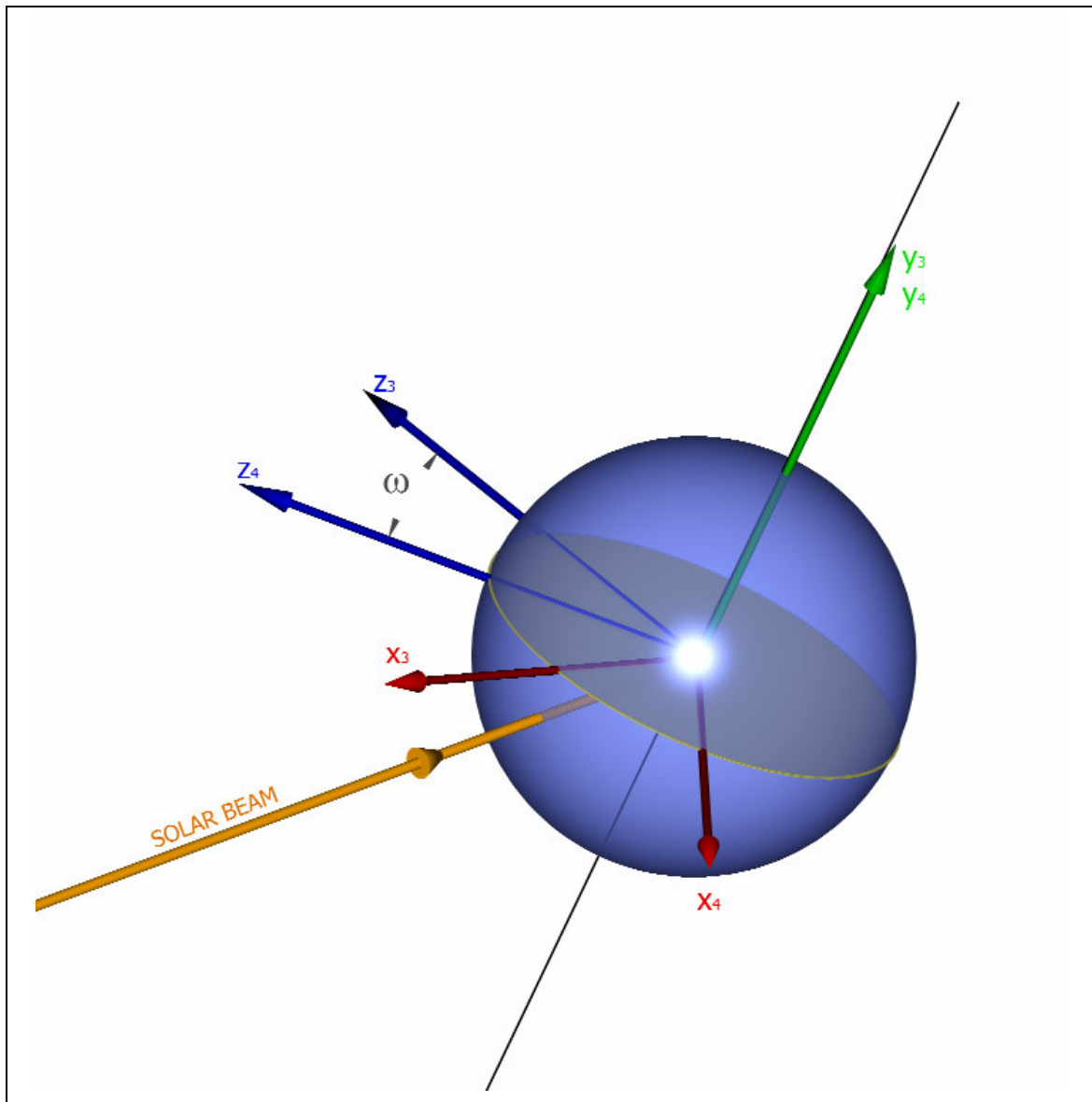

Figure 2.17. Rotation #4 (Rotation of KS_3)

2.3.6.6. Rotation #5

KS_4 is rotated with ϕ angle about z_4 axis. (Figure 2.18.). ϕ angle is defined as latitude angle. In northern hemisphere ϕ is (+), in southern hemisphere it is (-).

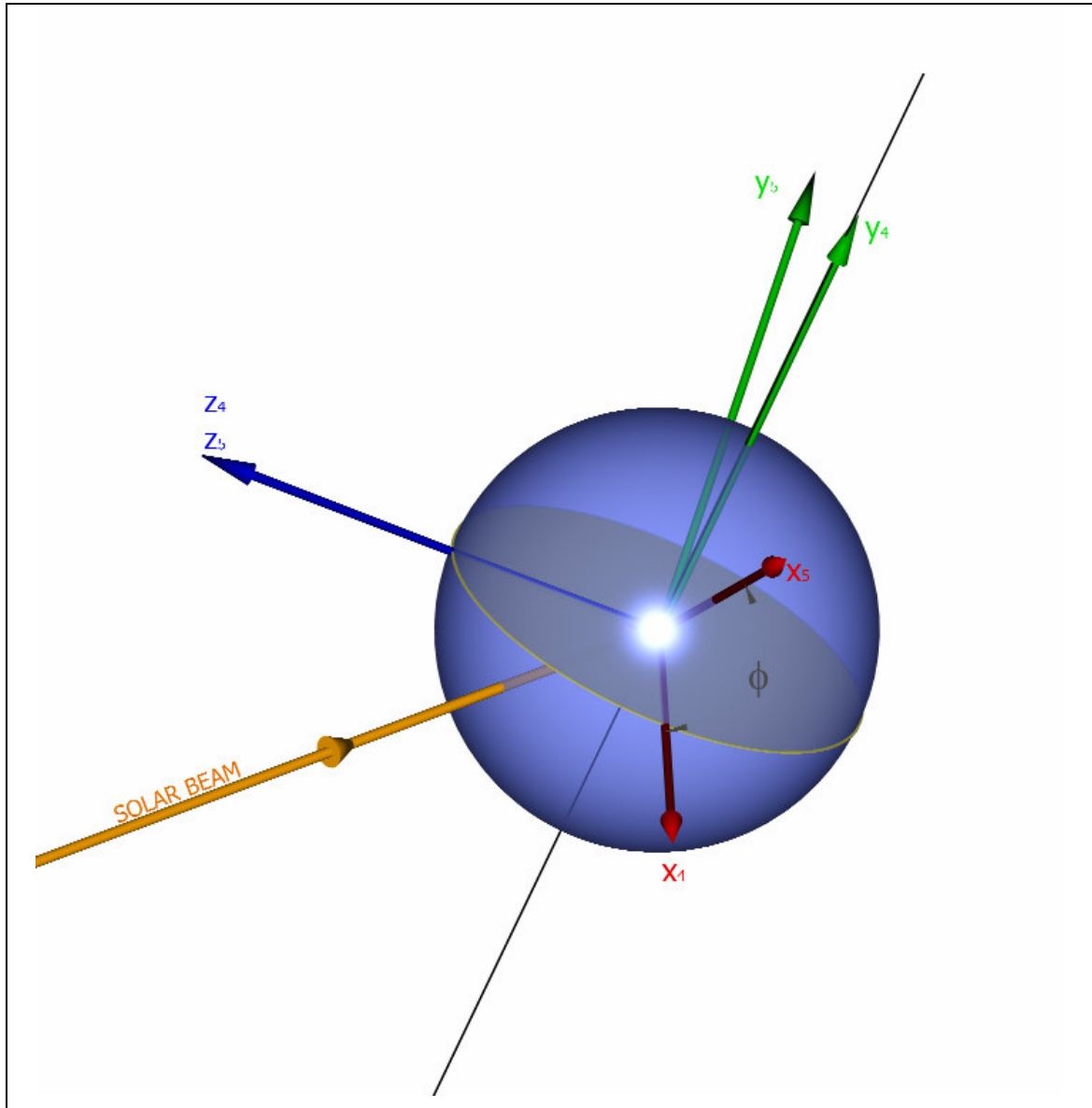

Figure 2.18. Rotation #5 (Rotation of KS_4)

2.3.6.7. Rotation #6

In (Figure 2.19) the result of the first 5 rotation can be seen.

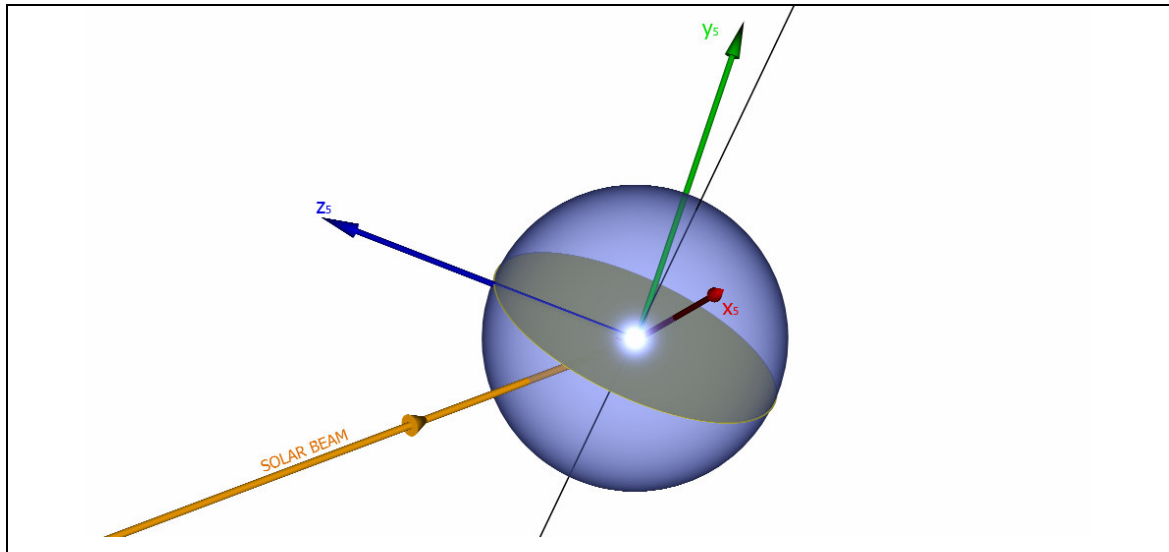

Figure 2.19. KS_5

Until this point, coordinate system origins, which were located at the center of the earth, were rotated. At this point the coordinate system KS_5 should have been translated to the surface of the earth. Earth radius is very small relative to the distance to the sun so this translation action is ignored. In other terms KS_5 coordinate system is translated to surface of the earth and still called KS_5 (Figure 2.20).

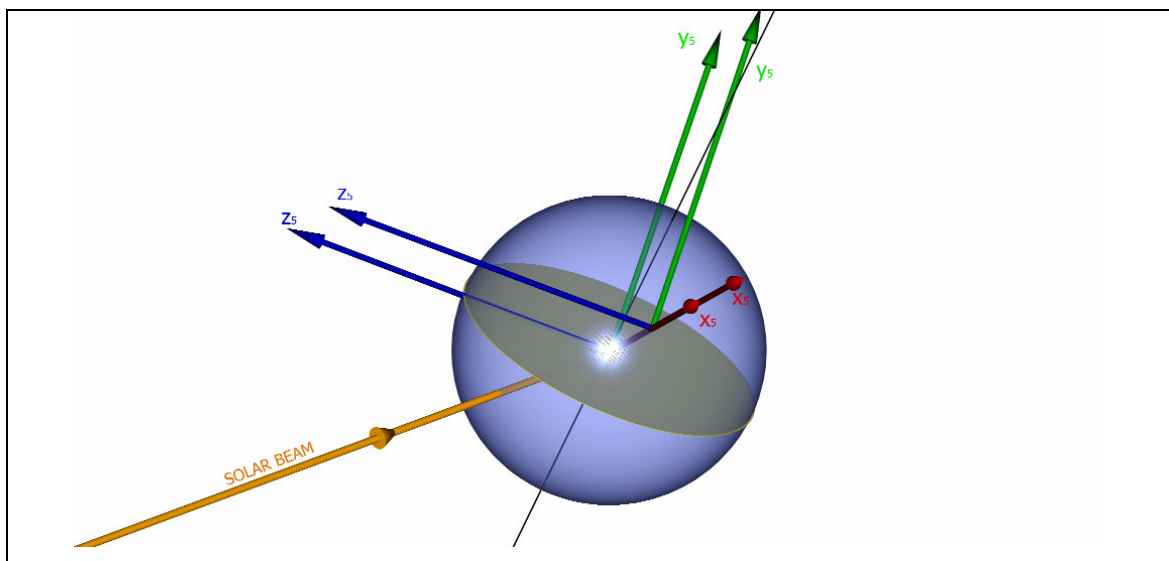

Figure 2.20. KS_5

KS_5 is placed on a horizontal plane on the surface of the earth. This coordinate system specifies the plane in the day angled α , at the hour angled ω , in the latitude angled ϕ . The final rotation angle β is the angle required to reflect the solar beams to the desired location. The β angle should be calculated. In other words rotating KS_5 about y_5 axis with the calculated angle β creates KS_6 (Figure 2.21.).

2.3.6.8. Final Coordinate System (KS_6)

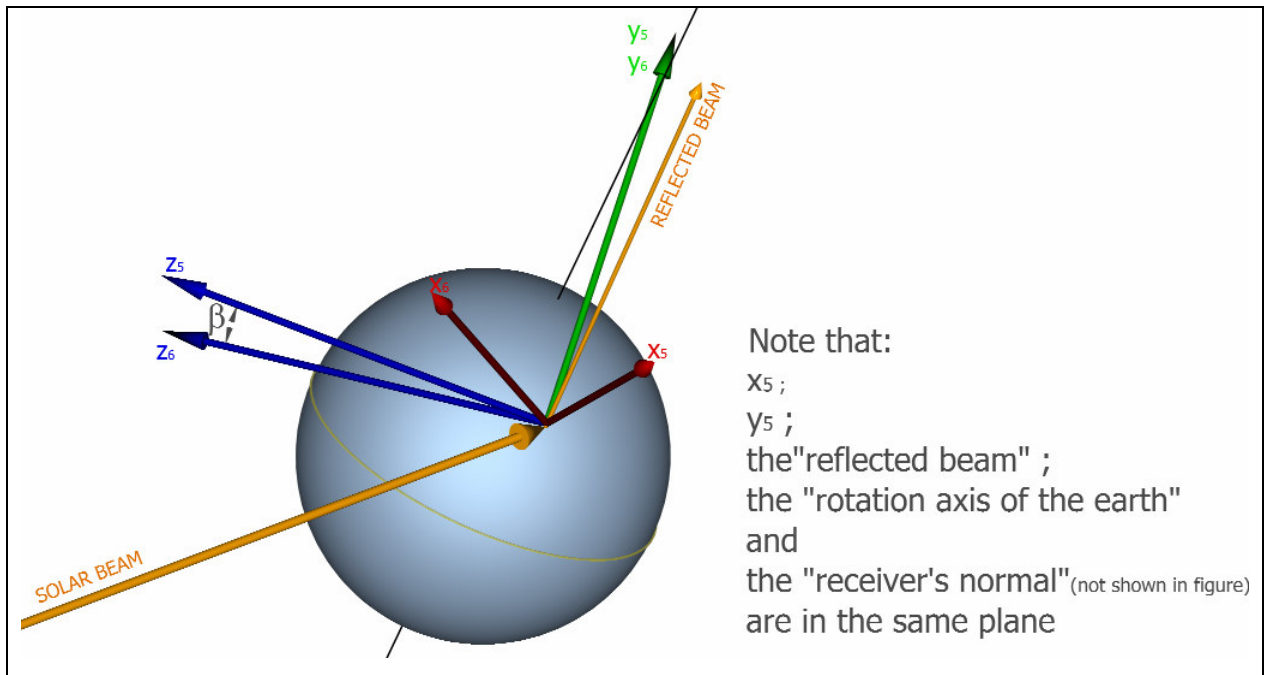

Figure 2.21. Rotation #6 (Rotation of KS_5)

The reflector plane placed on the coordinate system KS_6 can reflect solar beams to the receiver right above (Figure 2.22.).

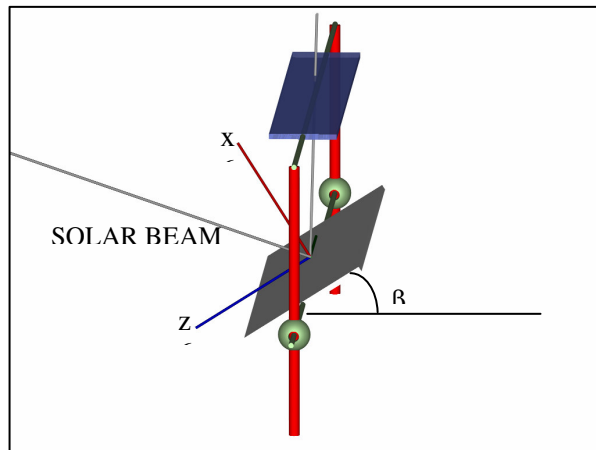
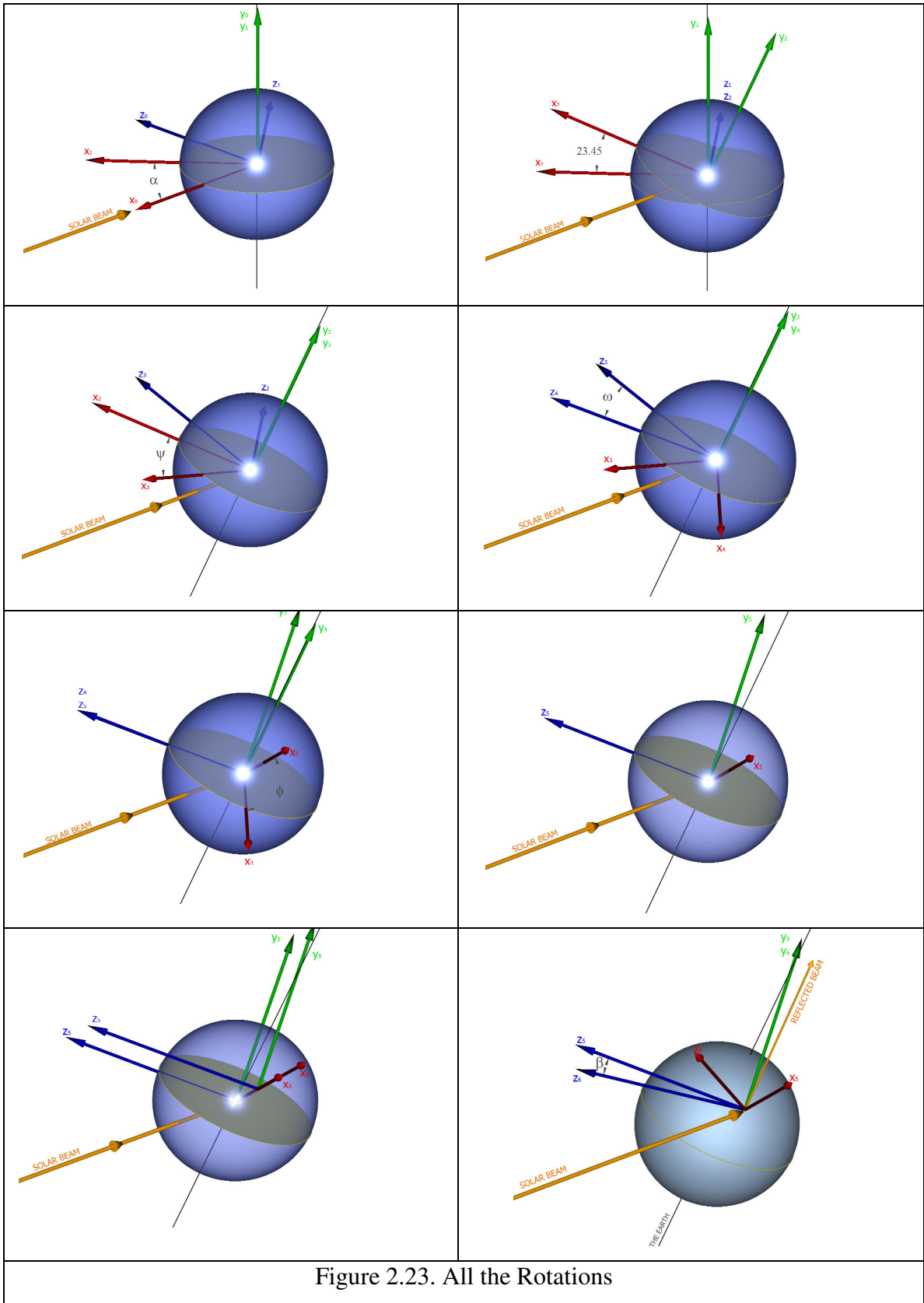

Figure 2.22. β Angle

All the rotations and created coordinate systems are shown together in
(Figure 2.23.)



2.3.7. Matrix Multiplication

Expression of the first coordinate system KS_0 in terms of KS_6 (final coordinate system) is shown below.

$$\begin{array}{c} \left| \begin{array}{c} x_6 \\ y_6 \\ z_6 \end{array} \right| = \left| \begin{array}{c} R_y(\beta) \\ * \\ R_z(\phi) \\ * \\ R_y(\omega) \\ * \\ R_y(\psi) \\ * \\ R_z(23,45) \\ * \\ R_y(\alpha) \\ * \end{array} \right| \left| \begin{array}{c} x_0 \\ y_0 \\ z_0 \end{array} \right| \\ \text{KS}_6 \quad \text{KS}_5 \quad \text{KS}_4 \quad \text{KS}_3 \quad \text{KS}_2 \quad \text{KS}_1 \quad \text{KS}_0 \end{array}$$

The meaning of this multiplication is;

A vector defined in KS_0 with x_0, y_0, z_0 can be defined in KS_6 with x_6, y_6, z_6

In other words

$$\vec{r} = x_0 \vec{i}_0 + y_0 \vec{j}_0 + z_0 \vec{k}_0 = x_6 \vec{i}_6 + y_6 \vec{j}_6 + z_6 \vec{k}_6 \quad (2.16.)$$

Multiplying the matrices:

To make the matrix multiplying expressions simpler letters are assigned for the trigonometric values.

$$A = \cos\alpha$$

$$B = \sin\alpha$$

$$C = \cos 23,45$$

$$D = \sin 23,45$$

$$E = \cos \psi$$

$$F = \sin\psi$$

$$G = \cos\omega$$

$$H = \sin\omega$$

$$I = \cos\phi$$

$$J = \sin\phi$$

$$K = \cos\beta$$

$$L = \sin\beta$$

$$\begin{array}{c} \left| \begin{array}{c} x_6 \\ y_6 \\ z_6 \end{array} \right| = \left| \begin{array}{c} R_y(\beta) \\ * \\ R_z(\phi) \\ * \\ R_y(\omega) \\ * \\ R_y(\psi) \\ * \\ R_z(23.45) \\ * \\ R_y(\alpha) \\ * \end{array} \right| \left| \begin{array}{c} x_0 \\ y_0 \\ z_0 \end{array} \right| \\ \text{KS}_6 \qquad \qquad \text{KS}_5 \qquad \qquad \text{KS}_4 \qquad \qquad \text{KS}_3 \qquad \qquad \text{KS}_2 \qquad \qquad \text{KS}_1 \qquad \qquad \text{KS}_0 \end{array}$$

$$\begin{array}{c} \left| \begin{array}{c} x_6 \\ y_6 \\ z_6 \end{array} \right| = \left| \begin{array}{ccc} \cos\beta & 0 & -\sin\beta \\ 0 & 1 & 0 \\ \sin\beta & 0 & \cos\beta \end{array} \right| * \left| \begin{array}{ccc} \cos\phi & \sin\phi & 0 \\ -\sin\phi & \cos\phi & 0 \\ 0 & 0 & 1 \end{array} \right| * \left| \begin{array}{ccc} \cos\omega & 0 & -\sin\omega \\ 0 & 1 & 0 \\ \sin\omega & 0 & \cos\omega \end{array} \right| * \left| \begin{array}{ccc} \cos\psi & 0 & -\sin\psi \\ 0 & 1 & 0 \\ \sin\psi & 0 & \cos\psi \end{array} \right| * \left| \begin{array}{ccc} \cos 23.45 & \sin 23.45 & 0 \\ -\sin 23.45 & \cos 23.45 & 0 \\ 0 & 0 & 1 \end{array} \right| * \left| \begin{array}{ccc} \cos\alpha & 0 & -\sin\alpha \\ 0 & 1 & 0 \\ \sin\alpha & 0 & \cos\alpha \end{array} \right| \left| \begin{array}{c} x_0 \\ y_0 \\ z_0 \end{array} \right| \\ \text{KS}_6 \qquad \qquad \text{KS}_5 \qquad \qquad \text{KS}_4 \qquad \qquad \text{KS}_3 \qquad \qquad \text{KS}_2 \qquad \qquad \text{KS}_1 \qquad \qquad \text{KS}_0 \end{array}$$

$$\begin{array}{c} \left| \begin{array}{c} x_6 \\ y_6 \\ z_6 \end{array} \right| = \left| \begin{array}{ccc} K & 0 & -L \\ 0 & 1 & 0 \\ L & 0 & K \end{array} \right| * \left| \begin{array}{ccc} I & J & 0 \\ -J & I & 0 \\ 0 & 0 & 1 \end{array} \right| * \left| \begin{array}{ccc} G & 0 & -H \\ 0 & 1 & 0 \\ H & 0 & G \end{array} \right| * \left| \begin{array}{ccc} E & 0 & -F \\ 0 & 1 & 0 \\ F & 0 & E \end{array} \right| * \left| \begin{array}{ccc} C & D & 0 \\ -D & C & 0 \\ 0 & 0 & 1 \end{array} \right| * \left| \begin{array}{ccc} A & 0 & -B \\ 0 & 1 & 0 \\ B & 0 & A \end{array} \right| \left| \begin{array}{c} x_0 \\ y_0 \\ z_0 \end{array} \right| \\ \text{KS}_6 \qquad \qquad \text{KS}_5 \qquad \qquad \text{KS}_4 \qquad \qquad \text{KS}_3 \qquad \qquad \text{KS}_2 \qquad \qquad \text{KS}_1 \qquad \qquad \text{KS}_0 \end{array}$$

2.3.8. Matrix Representations of Reflection

Reflection in yz plane

$$\begin{vmatrix} -1 & 0 & 0 \\ 0 & 1 & 0 \\ 0 & 0 & 1 \end{vmatrix}$$

Reflection in xz plane

$$\begin{vmatrix} 1 & 0 & 0 \\ 0 & -1 & 0 \\ 0 & 0 & 1 \end{vmatrix}$$

Reflection in xy plane

$$\begin{vmatrix} 1 & 0 & 0 \\ 0 & 1 & 0 \\ 0 & 0 & -1 \end{vmatrix}$$

2.3.9. Defining the Reflected Solar Beam Vector

A vector defined in KS_0 with x_0, y_0, z_0 can now be defined as x_6, y_6, z_6 in KS_6 . As commented before coordinate system KS_6 was created to define a reflector placed in a specific location (latitude and longitude are known), at a certain time and day, which is rotated with β angle around its axis (axis is placed North-South direction).

In this case previously described solar beam $\vec{G} = -\vec{b}$ in KS_0 can be written in KS_6 . To define the reflected solar beam, vector defined in KS_6 should be reflected in y_6 - z_6 plane. As a result of this reflection y and z components of the solar beam vector stays unchanged while x component, directed at the reflectors normal, reverses.

Receiver' s coordinate system should be defined presuming that the reflected beam will be directed to the receiver placed right above the reflector. Rotating KS_6 coordinate system with $-\beta$ angle will create KS_7 indicating coordinate systems of both the receiver and the horizontal plane. This plane is defined at y - z . The planes normal is defined in x .

The reflected beam is rewritten in KS_7. When the z component of the KS_7 coordinate system is zero the reflected beam reaches the receiver right on top of the reflector. When this situation is analyzed β angle can be calculated.

Solar beam \vec{G} is defined at the final matrix;

$$x_0 = -1$$

$$y_0 = 0$$

$$z_0 = 0$$

is converted;

$$x_6 = -ACEGIK+FBGIK+ACFHIK+BEHIK+ADJK +ACEHL-FBHL+ACFGL+B EGL$$

$$y_6 = ACEGJ-FBGJ-ACFHJ-BEHJ+ADI$$

$$z_6 = -ACEGIL+FBGIL+ACFHIL+BEHIL+ADJL-ACEHK+FBHK-ACFGK-BEGK$$

reflected solar beam is defined by keeping the y-z components same while reversing the sign of the x component of the vector.

$$x_6 = ACEGIK-FBGIK-ACFHIK-BEHIK-ADJK -ACEHL+FBHL-ACFGL-B EGL$$

$$y_6 = ACEGJ-FBGJ-ACFHJ-BEHJ+ADI$$

$$z_6 = -ACEGIL+FBGIL+ACFHIL+BEHIL+ADJL-ACEHK+FBHK-ACFGK-BEGK$$

To express this vector on the horizontal plane (KS_7) it is rotated about y_6 axis with $-\beta$ angle. It can be seen that KS_7 and KS_5 are the same coordinate systems with the same origin and axis.

$$\begin{array}{l|l}
x_7 \\
y_7 \\
z_7
\end{array} = R_y(-\beta) * \begin{array}{l}
\text{ACEGIK-FBGIK-ACFHIK-BEHIK-ADJK -ACEHL+FBHL-ACFGL-BEGL} \\
\text{ACEGJ-FBGJ-ACFHJ-BEHJ+ADI} \\
\text{-ACEGIL+FBGIL+ACFHIL+BEHIL+ADJL-ACEHK+FBHK-ACFGK-BEGK}
\end{array}$$

$$\begin{array}{l|l}
x_7 \\
y_7 \\
z_7
\end{array} = \begin{array}{l|l}
\cos-\beta & 0 & -\sin-\beta \\
0 & 1 & 0 \\
\sin-\beta & 0 & \cos-\beta
\end{array} * \begin{array}{l}
\text{ACEGIK-FBGIK-ACFHIK-BEHIK-ADJK -ACEHL+FBHL-ACFGL-BEGL} \\
\text{ACEGJ-FBGJ-ACFHJ-BEHJ+ADI} \\
\text{-ACEGIL+FBGIL+ACFHIL+BEHIL+ADJL-ACEHK+FBHK-ACFGK-BEGK}
\end{array}$$

$$\begin{array}{l|l}
x_7 \\
y_7 \\
z_7
\end{array} = \begin{array}{l|l}
\text{K} & 0 & \text{L} \\
0 & 1 & 0 \\
-\text{L} & 0 & \text{K}
\end{array} * \begin{array}{l}
\text{ACEGIK-FBGIK-ACFHIK-BEHIK-ADJK -ACEHL+FBHL-ACFGL-BEGL} \\
\text{ACEGJ-FBGJ-ACFHJ-BEHJ+ADI} \\
\text{-ACEGIL+FBGIL+ACFHIL+BEHIL+ADJL-ACEHK+FBHK-ACFGK-BEGK}
\end{array}$$

$$\begin{array}{l|l}
x_7 \\
y_7 \\
z_7
\end{array} = \begin{array}{l}
\text{K} \cdot (\text{ACEGIK-FBGIK-ACFHIK-BEHIK-ADJK -ACEHL+FBHL-ACFGL-BEGL}) \\
-\text{L} \cdot (\text{-ACEGIL+FBGIL+ACFHIL+BEHIL+ADJL-ACEHK+FBHK-ACFGK-BEGK}) \\
\text{ACEGJ-FBGJ-ACFHJ-BEHJ+ADI} \\
-\text{L} \cdot (\text{ACEGIK-FBGIK-ACFHIK-BEHIK-ADJK -ACEHL+FBHL-ACFGL-BEGL}) \\
+\text{K} \cdot (\text{-ACEGIL+FBGIL+ACFHIL+BEHIL+ADJL-ACEHK+FBHK-ACFGK-BEGK})
\end{array}$$

2.3.9.1. z Component

z component of the reflected solar beam vector defined in KS_7 is zero when the reflected beam reaches the receiver right on top of the reflector.

$$z_7 = 0 = -L \cdot (\text{ACEGIK-FBGIK-ACFHIK-BEHIK-ADJK} - \text{ACEHL+FBHL-ACFGL-BEGL}) \\ + K \cdot (-\text{ACEGIL+FBGIL+ACFHIL+BEHIL+ADJL-ACEHK+FBHK-ACFGK-BEGK})$$

$$z_7 = 0 = \text{ACEGIKL-FBGIKL-ACFHILK-BEHIKL-ADJKL} - \text{ACEHLL+FBHLL-ACFGLL-BEGLL} \\ + \text{ACEGILK-FBGILK-ACFHILK-BEHILK-ADJLK} + \text{ACEHKK-FBHKK+ACFGKK+BEGKK}$$

$$z_7 = 0 =$$

$$\text{LL} \cdot (-\text{ACEH+FBH-ACFG-BEG}) +$$

$$\text{KL} \cdot (\text{ACEGI-FBGI-ACFHI-BEHI-ADJ} + \text{ACEGI-FBGI-ACFHI-BEHI} + \text{ADJ}) +$$

$$\text{KK} \cdot (\text{ACEH-FBH+ACFG+BEG})$$

to find the root values of the equation;

$$\frac{-b \pm \sqrt{b^2 - 4ac}}{2a} \quad \text{Quadratic formula is used.}$$

To transform the equation into $L^2a + Lb + c = 0$ form;

$$a = -\text{ACEH} + \text{FBH} - \text{ACFG} - \text{BEG}$$

$$b = 2K(\text{ACEGI} - \text{FBGI} - \text{ACFHI} - \text{BEHI} - \text{ADJ})$$

$$c = KK(\text{ACEH} - \text{FBH} + \text{ACFG} + \text{BEG})$$

$$p = \text{ACEGI} - \text{FBGI} - \text{ACFHI} - \text{BEHI} - \text{ADJ}$$

$$q = \text{ACEH} - \text{FBH} + \text{ACFG} + \text{BEG} = -a$$

$$b = 2Kp$$

$$c = -KKa$$

$$\frac{-2Kp \pm \sqrt{4K^2 p^2 + 4a^2 K^2}}{2a} = \frac{K(-2p \pm \sqrt{4p^2 + 4a^2})}{2a} = L$$

$$\frac{-p \pm \sqrt{p^2 + a^2}}{a} = \frac{L}{K} = \tan \beta$$

$$\beta = \arctan \frac{-p \pm \sqrt{p^2 + a^2}}{a}$$

There are 2 root values with 90 degrees difference.

2.3.9.2. X and Y Components

x_7 , y_7 , z_7 components define the "solar beam vector \vec{G} " at KS_7. It is known that when z_7 is equal to zero, solar beam reaches to the receiver. The other components y_7 and x_7 can be explained as follows (Figure 2.24.);

x_7 component defines the vertical distance between the receiver and the reflectors rotation axis. x_7 is a constant value for a given system. x_7 is called "h".

y_7 component defines the horizontal distance that the solar beam reaches (In the north-south direction). This variable is called "v".

Scalar values can be reached by inputting the requested angles in x_7 and y_7 components. And the equation below can be written.

$$\mathbf{v} = \mathbf{h} \cdot y_7 / x_7 \quad (2.17)$$

"v" variable continuously changes during the day and the year. Minimum and maximum values can be determined by calculating the values for entire year.

This calculation reveals the minimum length of the receiver. By this way receiver can be designed at exact length. Smaller lengths would have made the solar beams pass without hitting the receiver while longer lengths would create heat losses.

Also positioning the receiver will be made with the help of these calculations.

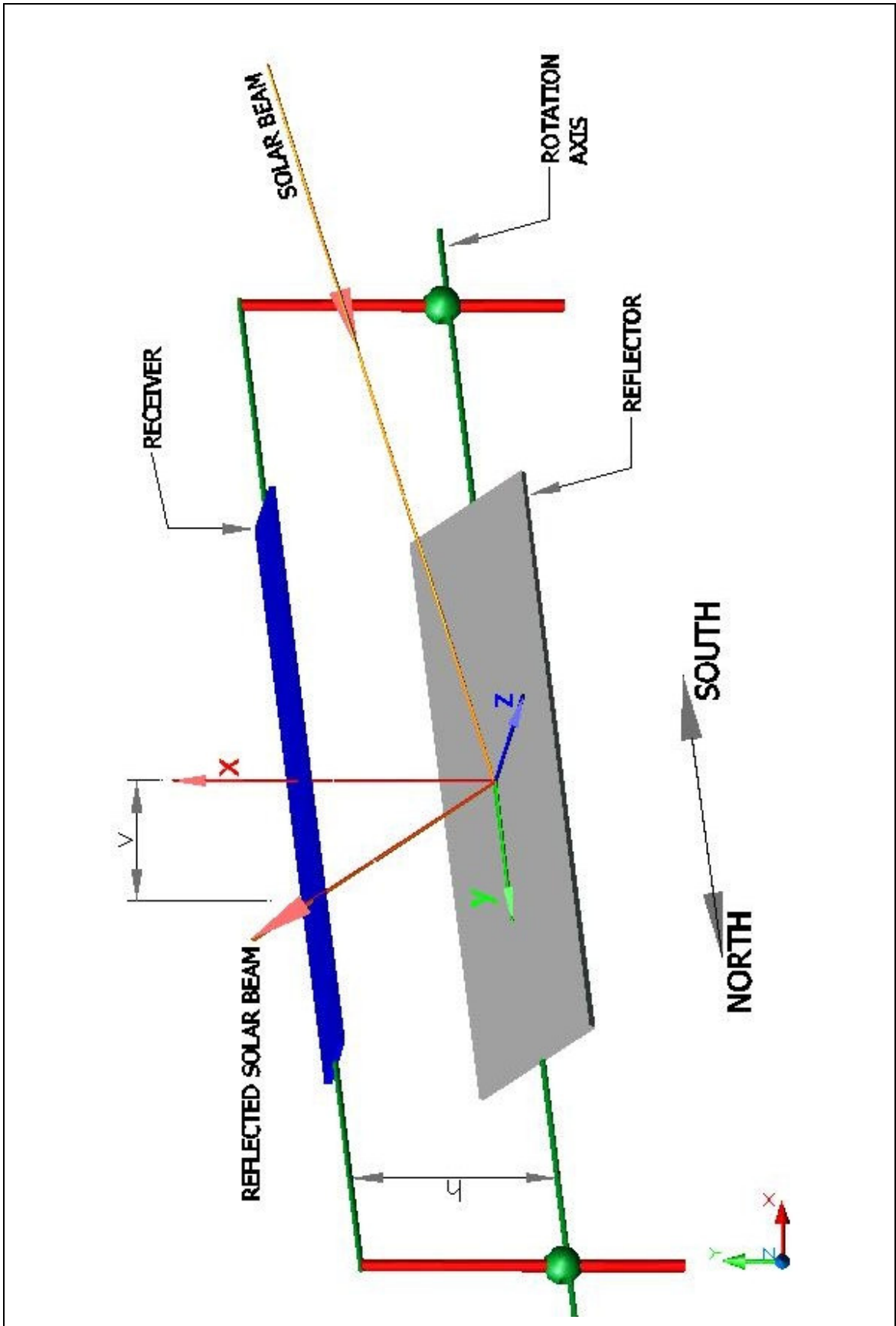

Figure 2.24. x and y components

2.3.10. ψ Angle

β angle is composed of variables.

$$f(\beta) = f(\alpha; 23,45; \psi; \omega; \phi)$$

function can be defined.

α : It is depended on number of the days up from 21st of December (Figure-2.10)

23,45 : Constant value equal to the inclination angle of earth.

ω : Hour angle. It states the angular difference to the solar noon. Before solar noon ω is valued (-); after solar noon ω is valued (+).

ϕ : Latitude angle

ψ angle should be calculated. To reach the solar noon the model should be rotated about y_2 axis. To calculate ψ angle scalar product of vectors and the extremum conditions are applied.

When turned to first 4 matrices multiplication;

$$\begin{array}{c} \left| \begin{array}{c} x_3 \\ y_3 \\ z_3 \end{array} \right| = \begin{array}{c} \left| \begin{array}{c} R_y(\psi) \\ * \\ R_z(23,45) \\ * \\ R_y(\alpha) \\ * \end{array} \right| \left| \begin{array}{c} x_0 \\ y_0 \\ z_0 \end{array} \right| \end{array}$$

KS_3 KS_2 KS_1 KS_0

The result is:

$$\left| \begin{array}{c} x_3 \\ y_3 \\ z_3 \end{array} \right| = \left| \begin{array}{ccc} ACE-FB & ED & -CBE-FA \\ -AD & C & DB \\ ACF+BE & FD & -FCB+EA \end{array} \right| \left| \begin{array}{c} x_0 \\ y_0 \\ z_0 \end{array} \right|$$

Solar beam vector \vec{G} can be defined with x_3, y_3, z_3 in KS_3;

$$\vec{G} = -1 * \vec{i}_0 + 0 * \vec{j}_0 + 0 * \vec{k}_0 = x_3 \vec{i}_3 + y_3 \vec{j}_3 + z_3 \vec{k}_3 \quad (2.18)$$

In this case;

$$\begin{vmatrix} x_3 \\ y_3 \\ z_3 \end{vmatrix} = \begin{vmatrix} ACE-FB & ED & -CBE-FA \\ -AD & C & DB \\ ACF+BE & FD & -FCB+EA \end{vmatrix} * \begin{vmatrix} -1 \\ 0 \\ 0 \end{vmatrix}$$

\vec{G} vector obtained from the multiplication is the solar beam defined at KS_3.

It can be sad that when a rotation \square is made in y_2 axis to catch up with solar noon, scalar multiplication result of reflector's normal vector and solar beam's vector should be so that the angle δ in between is maximum. In horizontal position the normal of the reflector plane is (\vec{i}_3) unit vector.

$$|\vec{G}| * |\vec{i}_3| * \cos \delta = \sqrt{x_3^2 + y_3^2 + z_3^2} \cdot 1 \cdot \cos \delta = (x_3 \vec{i}_3 + y_3 \vec{j}_3 + z_3 \vec{k}_3) * (\vec{i}_3) = x_3$$

$$\sqrt{x_3^2 + y_3^2 + z_3^2} = 1$$

$$\cos \delta = x_3 = -ACE+FB = -\cos\alpha \cdot \cos 23,45 \cdot \cos\psi + \sin\psi \cdot \sin\alpha \quad (2.19)$$

By taking derivative of the equation and equating them to zero, the peak values (max/min values) can be found.

($\cos\alpha$; $\cos 23,45$; $\sin\alpha$ are constant values in the case)

$$(\cos \delta)' = \cos\alpha \cdot \cos 23,45 \cdot \sin\psi + \cos\psi \cdot \sin\alpha = 0$$

$$\psi = \arctan(-\tan\alpha / \cos\delta) \quad (2.20)$$

is found.

ψ angle is defined in (Equation 2.20) which is obtained by scalar product of vectors and taking derivative. This function can provide maximum and minimum values. When the calculated ψ angle from (Equation 2.20) is inserted in (Equation 2.19);

$$-1 \leq \cos \delta \leq 1$$

is seen. Minimum and maximum values of $(\cos \delta)$ is observed.

Because of the structural features of the subjected model, following statement can be written.

$$90 \leq \delta \leq 180$$

In this case $\cos \delta$ is;

$$-1 \leq \cos \delta \leq 0$$

When calculating the arctangent values at a computer the answer is always between $-90/+90$ degrees. So every ψ angle should be checked to determine whether if it is a maximum.

Calculated ψ angle must be inserted into the (Equation 2.19) and checked if the $-1 \leq \cos \delta \leq 0$ condition is obtained. If the condition is obtained then the operation should be completed. If the condition is not obtained then 180° is added to the ψ angle and then the calculations can be completed.

If $-1 \leq \cos \delta \leq 0$ then use directly ψ

If $0 \leq \cos \delta \leq 1$ then use $\psi + 180$

2.3.11 Simplifying the Calculations

β angle can be obtained after multiplication of 6 matrices. However in this operation there are two consecutive rotations that are about the same axis. First rotation is ψ in KS_2 about the y_2 axis and the following rotation of ω in KS_3 about y_3 axis. These two consecutive rotations can be combined together and stated in a single matrix. And total operation is reduced to 5 matrix multiplications.

1. KS_0 is rotated with an α angle about the y_0 axis. Rotation angle α is calculated by determining the days from the 21st of December.
2. KS_1 is rotated $23,45^\circ$ about the z_1 axis.
3. KS_2 is rotated $(\psi + \omega)$ degrees about the y_2 axis.

2 consecutive rotations in y axis are combined.

4. KS_3 is rotated with ϕ angle about z_3 . ϕ is defined as "Latitude Angle", In northern hemisphere, sign of ϕ is (+), in southern hemisphere it is (-).
5. KS_4 is rotated about y_4 axis with the calculated angle β . Final coordinate system KS_5 is created.

Expression of the first coordinate system KS_0 in terms of KS_5 (final coordinate system) is shown below.

$$\begin{array}{c} \left| \begin{array}{c} x_5 \\ y_5 \\ z_5 \end{array} \right| = \left| \begin{array}{c} R_y(\beta) \\ * \\ R_z(\phi) \\ * \\ R_y(\psi+\omega) \\ * \\ R_z(23,45) \\ * \\ R_y(\alpha) \\ * \end{array} \right| \left| \begin{array}{c} x_0 \\ y_0 \\ z_0 \end{array} \right| \\ \text{KS}_5 \quad \text{KS}_4 \quad \text{KS}_3 \quad \text{KS}_2 \quad \text{KS}_1 \quad \text{KS}_0 \end{array}$$

The meaning of this multiplication is;

A vector defined in KS_0 with x_0, y_0, z_0 can be defined in KS_5 with x_5, y_5, z_5

In other words

$$\vec{r} = x_0 \vec{i}_0 + y_0 \vec{j}_0 + z_0 \vec{k}_0 = x_5 \vec{i}_5 + y_5 \vec{j}_5 + z_5 \vec{k}_5$$

Multiplying the matrices:

To make the matrix multiplying expressions simpler, letters are assigned for the trigonometric values.

$$A = \cos \alpha$$

$$B = \sin \alpha$$

$$C = \cos 23,45$$

$$D = \sin 23,45$$

$$E = \cos (\psi + \omega)$$

$$F = \sin (\psi + \omega)$$

$$G = \cos \phi$$

$$H = \sin \phi$$

$$I = \cos \beta$$

$$J = \sin \beta$$

$$\begin{array}{c} \left| \begin{array}{c} x_5 \\ y_5 \\ z_5 \end{array} \right| \\ = \\ \left| \begin{array}{c} R_y(\beta) \\ * \\ R_z(\phi) \\ * \\ R_y(\psi+\omega) \\ * \\ R_z(23.45) \\ * \\ R_y(\alpha) \\ * \end{array} \right| \left| \begin{array}{c} x_0 \\ y_0 \\ z_0 \end{array} \right| \\ \text{KS}_5 \qquad \qquad \text{KS}_4 \qquad \qquad \text{KS}_3 \qquad \qquad \text{KS}_2 \qquad \qquad \text{KS}_1 \qquad \qquad \text{KS}_0 \end{array}$$

$$\begin{array}{c} \left| \begin{array}{c} x_5 \\ y_5 \\ z_5 \end{array} \right| \\ = \\ \left| \begin{array}{ccc} \cos\beta & 0 & -\sin\beta \\ 0 & 1 & 0 \\ \sin\beta & 0 & \cos\beta \end{array} \right| * \left| \begin{array}{ccc} \cos\phi & \sin\phi & 0 \\ -\sin\phi & \cos\phi & 0 \\ 0 & 0 & 1 \end{array} \right| * \left| \begin{array}{ccc} \cos(\psi+\omega) & 0 & -\sin(\psi+\omega) \\ 0 & 1 & 0 \\ \sin(\psi+\omega) & 0 & \cos(\psi+\omega) \end{array} \right| * \left| \begin{array}{ccc} \cos 23.45 & \sin 23.45 & 0 \\ -\sin 23.45 & \cos 23.45 & 0 \\ 0 & 0 & 1 \end{array} \right| * \left| \begin{array}{ccc} \cos\alpha & 0 & -\sin\alpha \\ 0 & 1 & 0 \\ \sin\alpha & 0 & \cos\alpha \end{array} \right| \left| \begin{array}{c} x_0 \\ y_0 \\ z_0 \end{array} \right| \\ \text{KS}_5 \qquad \qquad \text{KS}_4 \qquad \qquad \text{KS}_3 \qquad \qquad \text{KS}_2 \qquad \qquad \text{KS}_1 \qquad \qquad \text{KS}_0 \end{array}$$

$$\begin{array}{c} \left| \begin{array}{c} x_5 \\ y_5 \\ z_5 \end{array} \right| \\ = \\ \left| \begin{array}{ccc} I & 0 & -J \\ 0 & 1 & 0 \\ J & 0 & I \end{array} \right| * \left| \begin{array}{ccc} G & H & 0 \\ -H & G & 0 \\ 0 & 0 & 1 \end{array} \right| * \left| \begin{array}{ccc} E & 0 & -F \\ 0 & 1 & 0 \\ F & 0 & E \end{array} \right| * \left| \begin{array}{ccc} C & D & 0 \\ -D & C & 0 \\ 0 & 0 & 1 \end{array} \right| * \left| \begin{array}{ccc} A & 0 & -B \\ 0 & 1 & 0 \\ B & 0 & A \end{array} \right| \left| \begin{array}{c} x_0 \\ y_0 \\ z_0 \end{array} \right| \\ \text{KS}_5 \qquad \qquad \text{KS}_4 \qquad \qquad \text{KS}_3 \qquad \qquad \text{KS}_2 \qquad \qquad \text{KS}_1 \qquad \qquad \text{KS}_0 \end{array}$$

$$\begin{array}{c|c|c|c|c|c|c|c|c|c|c|c|c|c|c|c|c|c|c|c|c|c} x_5 & I & 0 & -J & G & H & 0 & E & 0 & -F & C & D & 0 & A & 0 & -B & x_0 \\ y_5 = & 0 & 1 & 0 & * & -H & G & 0 & * & 0 & 1 & 0 & * & -D & C & 0 & 0 & 1 & 0 & * & y_0 \\ z_5 & J & 0 & I & 0 & 0 & 1 & F & 0 & E & 0 & 0 & 1 & B & 0 & A & z_0 \end{array}$$

$$\begin{array}{c|c|c|c|c|c|c|c|c|c|c|c|c|c|c|c|c|c|c|c|c|c} x_5 & I & 0 & -J & G & H & 0 & E & 0 & -F & AC & D & -CB & x_0 \\ y_5 = & 0 & 1 & 0 & * & -H & G & 0 & * & 0 & 1 & 0 & * & -AD & C & DB & y_0 \\ z_5 & J & 0 & I & 0 & 0 & 1 & F & 0 & E & B & 0 & A & z_0 \end{array}$$

$$\begin{array}{c|c|c|c|c|c|c|c|c|c|c|c|c|c|c|c|c|c|c|c|c|c} x_5 & I & 0 & -J & G & H & 0 & ACE-FB & ED & -CBE-FA & x_0 \\ y_5 = & 0 & 1 & 0 & * & -H & G & 0 & * & -AD & C & DB & y_0 \\ z_5 & J & 0 & I & 0 & 0 & 1 & ACF+BE & FD & -FCB+EA & z_0 \end{array}$$

$$\begin{array}{c|c|c|c|c|c|c|c|c|c|c|c|c|c|c|c|c|c|c|c|c|c} x_5 & I & 0 & -J & ACEG-FBG-ADH & DEG+HC & -CBEG-FAG+DBH & x_0 \\ y_5 = & 0 & 1 & 0 & * & -ACEH+FBH-ADG & -DEH+CG & CBEH+FAH+DBG & y_0 \\ z_5 & J & 0 & I & ACF+BE & FD & -CBF+AE & z_0 \end{array}$$

$$\begin{array}{c|c|c|c|c|c|c|c|c|c|c|c|c|c|c|c|c|c|c|c|c|c} x_5 & ACEGI-FBGI-ADHI-ACFJ-BEJ & DEGI+HCI-FDJ & -CBEGI-FAGI+DBHI+CBFJ-AEJ & x_0 \\ y_5 = & -ACEH+FBH-ADG & -DEH-CG & CBEH+FAH+DBG & y_0 \\ z_5 & ACEGJ-FBGJ-ADHJ+ACFI+BEI & DEGJ+HCJ+FDI & -CBEGJ-FAGJ+DBHJ-CBFI+AEI & z_0 \end{array}$$

Solar beam was defined in KS_0 as follows;

$$x_0 = -1$$

$$y_0 = 0$$

$$z_0 = 0$$

And now it can be defined in KS_5 as follows;

$$x_5 = -ACEGI+FBGI+ADHI+ACFJ+BEJ$$

$$y_5 = ACEH-FBH+ADG$$

$$z_5 = -ACEGJ+FBGJ+ADHJ-ACFI-BEI$$

reflected solar beam is defined by keeping the y and z components same while reversing the sign of x component of the vector.

$$x_5 = ACEGI-FBGI-ADHI-ACFJ-BEJ$$

$$y_5 = ACEH-FBH+ADG$$

$$z_5 = -ACEGJ+FBGJ+ADHJ-ACFI-BEI$$

To express this vector on the horizontal plane (KS_6) it is rotated about y_5 axis with $(-\beta)$ angle.

$$\begin{vmatrix} x_6 \\ y_6 \\ z_6 \end{vmatrix} = \begin{vmatrix} & & & \\ & R_y(-\beta) & & \\ & & & \end{vmatrix} * \begin{vmatrix} ACEGI-FBGI-ADHI-ACFJ-BEJ \\ ACEH-FBH+ADG \\ -ACEGJ+FBGJ+ADHJ-ACFI-BEI \end{vmatrix}$$

$$\begin{vmatrix} x_6 \\ y_6 \\ z_6 \end{vmatrix} = \begin{vmatrix} \cos(-\beta) & 0 & -\sin(-\beta) \\ 0 & 1 & 0 \\ \sin(-\beta) & 0 & \cos(-\beta) \end{vmatrix} * \begin{vmatrix} ACEGI-FBGI-ADHI-ACFJ-BEJ \\ ACEH-FBH+ADG \\ -ACEGJ+FBGJ+ADHJ-ACFI-BEI \end{vmatrix}$$

$$\begin{vmatrix} x_6 \\ y_6 \\ z_6 \end{vmatrix} = \begin{vmatrix} I & 0 & J \\ 0 & 1 & 0 \\ -J & 0 & I \end{vmatrix} * \begin{vmatrix} ACEGI-FBGI-ADHI-ACFJ-BEJ \\ ACEH-FBH+ADG \\ -ACEGJ+FBGJ+ADHJ-ACFI-BEI \end{vmatrix}$$

$$\begin{vmatrix} x_6 \\ y_6 \\ z_6 \end{vmatrix} = \begin{vmatrix} I \cdot (ACEGI-FBGI-ADHI-ACFJ-BEJ) + J \cdot (-ACEGJ+FBGJ+ADHJ-ACFI-BEI) \\ ACEH-FBH+ADG \\ -J \cdot (ACEGI-FBGI-ADHI-ACFJ-BEJ) + I \cdot (-ACEGJ+FBGJ+ADHJ-ACFI-BEI) \end{vmatrix}$$

z component of the reflected solar beam defined in KS_6 is zero when the reflected beam reaches the receiver right on top of the reflector.

$$z_6 = 0 = -J \cdot (ACEGI-FBGI-ADHI-ACFJ-BEJ) + I \cdot (-ACEGJ+FBGJ+ADHJ-ACFI-BEI)$$

$$z_6 = 0 = ACEGIJ-FBGIJ-ADHIJ-ACFJJ-BEJJ + ACEGJI-FBGJI-ADHJI+ACFII+BEII$$

to find the root values of the equation;

$$\frac{-b \pm \sqrt{b^2 - 4ac}}{2a} \quad \text{Quadratic formula is used.}$$

To transform the equation into $J^2 a + Jb + c = 0$ form;

$$a = -ACF - BE$$

$$b = 2I(ACEG - FBG - ADH)$$

$$c = II(ACF + BE)$$

$$p = ACEG - FBG - ADH$$

$$q = ACF + BE = -a$$

$$b = 2Ip$$

$$c = -IIa$$

$$\frac{-2Ip \pm \sqrt{4I^2 p^2 + 4a^2 I^2}}{2a} = \frac{I(-2p \pm \sqrt{4p^2 + 4a^2})}{2a} = J$$

$$\frac{-p \pm \sqrt{p^2 + a^2}}{a} = \frac{J}{I} = \tan \beta$$

$$\beta = \arctan \frac{-p \pm \sqrt{p^2 + a^2}}{a}$$

There are 2 root values with 90 degrees difference.

FIRST EQUATION	SIMPLIFIED EQUATION
$\beta = \arctan \frac{-p \pm \sqrt{p^2 + a^2}}{a} \quad (2.21)$	$\beta = \arctan \frac{-p \pm \sqrt{p^2 + a^2}}{a} \quad (2.22)$
$a = -ACEH + FBH - ACFG - BEG$	$a = -ACF - BE$
$p = ACEGI - FBGI - ACFHI - BEHI - ADJ$	$p = ACEG - FBG - ADH$

As seen first equation is simplified by combining the consecutive rotations.

2.3.11. Possible Reflector Orientation for a more Efficient System

Up to this point, rotation (orientation) in only one axis is investigated. Rotation axis was in north-south direction and the reflector-receiver pair was in horizontal plane.

On the other hand it is well known that the collected solar energy increases when the solar incident angle decreases. This can be realized by orientation also about the axis in east-west direction (south facing). Because of the large size of the projected plant continuously rotation of the whole system about the second axis in the east-west direction is not possible. But the system can be set up with a constant "**south facing inclination angle (μ)**" so that the annual total radiation reaches to a maximum.

In order to achieve that goal some modifications can be made in (Equation 2.22). In this new situation, rotations to be made are listed below.

- 1) KS_0 is rotated with an α angle about the y_0 axis
- 2) KS_1 is rotated $23,45^\circ$ about the z_1 axis.
- 3) KS_2 is rotated with $(\psi+\omega)$ angle about the y_2 axis
- 4) KS_3 is rotated with ϕ angle about the z_3 axis
- 5) KS_4 is rotated with μ angle about the z_4 axis**
- 6) KS_5 is rotated with β angle about the y_5 axis

To be seen the 5th rotation is added which defines the rotation about the axis in east-west direction. At this point 2 consecutive rotations about z axis can be combined in order to simplify the final equation. ;

- 1) KS_0 is rotated with an α angle about the y_0 axis
- 2) KS_1 is rotated $23,45^\circ$ about the z_1 axis.
- 3) KS_2 is rotated with $(\psi+\omega)$ angle about the y_2 axis
- 4) KS_3 is rotated with $(\phi +\mu)$ angle about the z_3 axis**
- 5) KS_4 is rotated with β angle about the y_4 axis

In this case the structure of the consecutive rotations is the same with the previous one. Only the G and H change as follows.

PREVIOUS ASSIGMENTS	PRESENT ASSIGMENTS
$A = \cos\alpha$	$A = \cos\alpha$
$B = \sin\alpha$	$B = \sin\alpha$
$C = \cos 23,45$	$C = \cos 23,45$
$D = \sin 23,45$	$D = \sin 23,45$
$E = \cos (\psi+\omega)$	$E = \cos (\psi+\omega)$
$F = \sin (\psi+\omega)$	$F = \sin (\psi+\omega)$
$G = \cos\phi$	$G = \cos (\phi+\mu)$
$H = \sin\phi$	$H = \sin (\phi+\mu)$
$I = \cos\beta$	$I = \cos\beta$
$J = \sin\beta$	$J = \sin\beta$

2.3.14 Chapter 2 Summary

The optical relation between a single reflector and a receiver right above the reflector is investigated. Investigations in Chapter 2 are;

1. Rotation of the reflector about the axis in the north-south direction is investigated. Rotation angle (β) is calculated.
2. First calculation is simplified by combining the consecutive rotations.
3. The exact position of the reflected solar beam is defined in x , y and z components
4. The rotation angle (μ) about the axis in the east-west direction is added into the equation. This angle (μ) is called "south facing inclination angle"

β ANGLE FOR EAST-WEST ORIENTED SOUTH FACING REFLECTOR-RECEIVER PAIR	
$\beta = \arctan \frac{-p + \sqrt{p^2 + a^2}}{a}$	(2.26.)
$a = \cos \alpha \cdot \cos 23,45 \cdot \sin(\psi + \omega) - \sin \alpha \cdot \cos(\psi + \omega)$	(2.19.)
$p = \cos \alpha \cdot \cos 23,45 \cdot \cos(\psi + \omega) \cdot \cos(\phi + \mu) - \sin(\psi + \omega) \cdot \sin \alpha \cdot \cos(\phi + \mu) - \cos \alpha \cdot \sin 23,45 \cdot \sin(\phi + \mu)$	(2.22.)
α - DAY ANGLE 23,45 - INCLINATION OF EARTH ψ - ANGLE TO FIND THE SOLAR NOON ω - HOUR ANGLE ϕ - LATITUDE μ - SOUTH FACING INCLINATION (EAST-WEST ROTATION AXIS) β - INCLINATION ANGLE OF CENTRAL REFLECTOR	

Inclination angles (β) of the reflector are calculated for entire year. In case of different south facing angles.

1. Situation (Figure 2.25.) (Figure 2.26.)	Location	İZMİR
	Latitude	38,46
	Position of Reflector-Receiver Pair	Horizontal
2. Situation (Figure 2.27.) (Figure 2.28.)	Location	İZMİR
	Latitude	38,46
	Position of Reflector-Receiver Pair	$\mu=15,01^\circ$ South Facing
3. Situation (Figure 2.29.) (Figure 2.30.)	Location	İZMİR
	Latitude	38,46
	Position of Reflector-Receiver Pair	$\mu=23,45^\circ$ South Facing
4. Situation (Figure 2.31.) (Figure 2.32.)	Location	İZMİR
	Latitude	38,46
	Position of Reflector-Receiver Pair	$\mu=38,46^\circ$ South Facing
5. Situation (Figure 2.33.) (Figure 2.34.)	Location	İZMİR
	Latitude	38,46
	Position of Reflector-Receiver Pair	$\mu=61,91^\circ$ South Facing

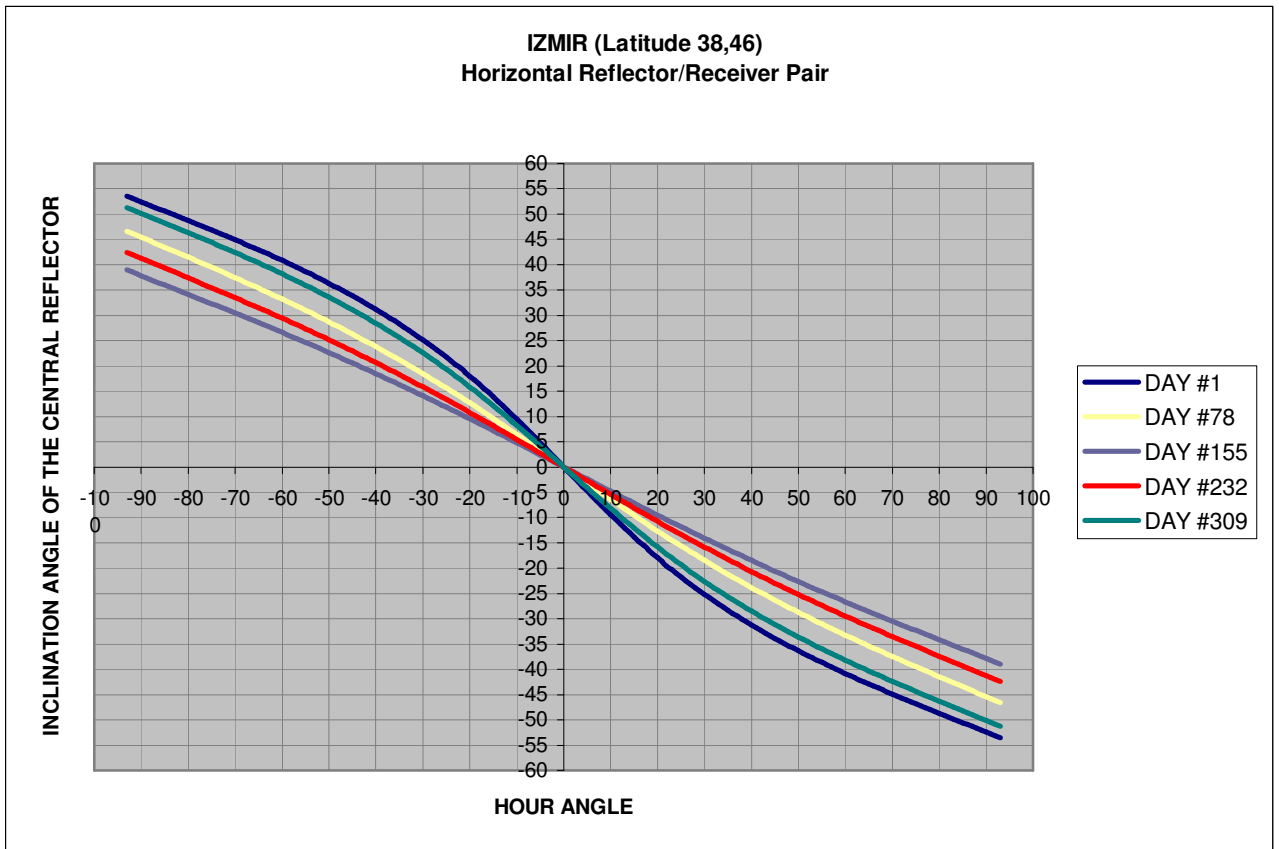

Figure 2.25. 2D Graphic for Horizontal Reflector-Receiver Pair

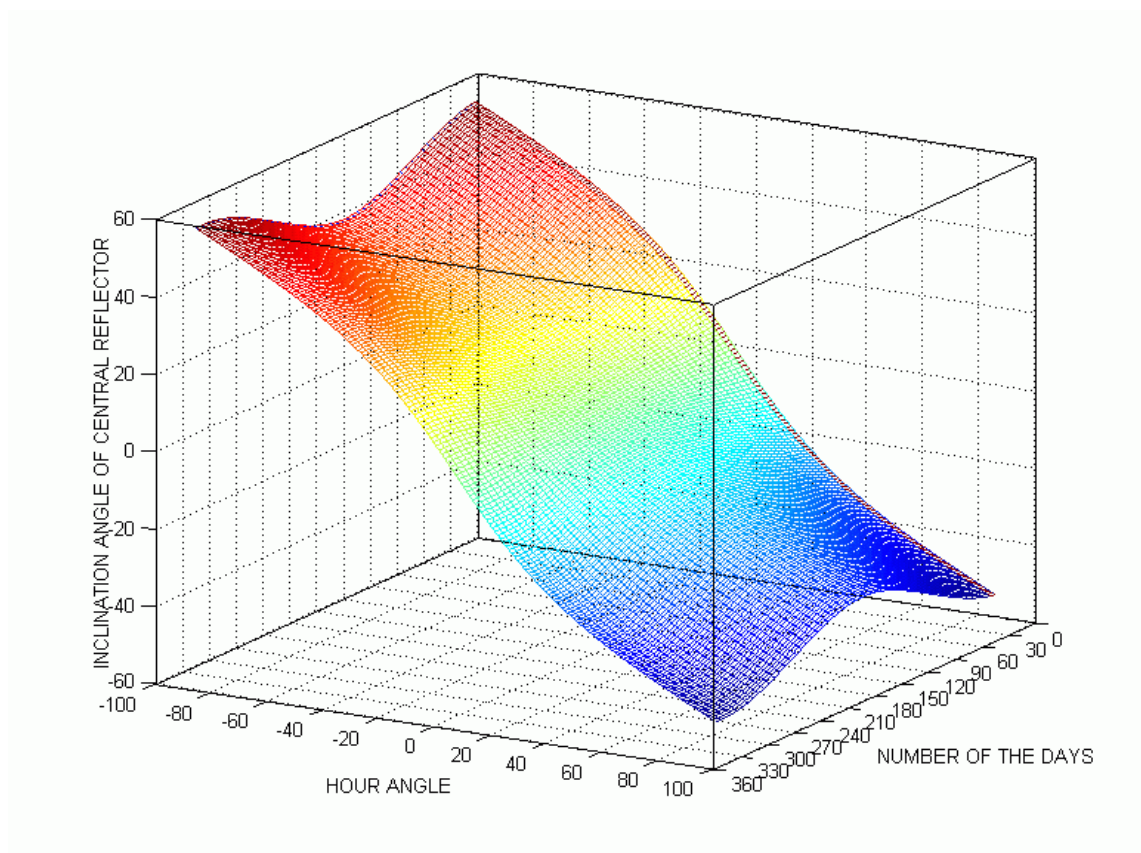

Figure 2.26. 3D Graphic for Horizontal Reflector-Receiver Pair

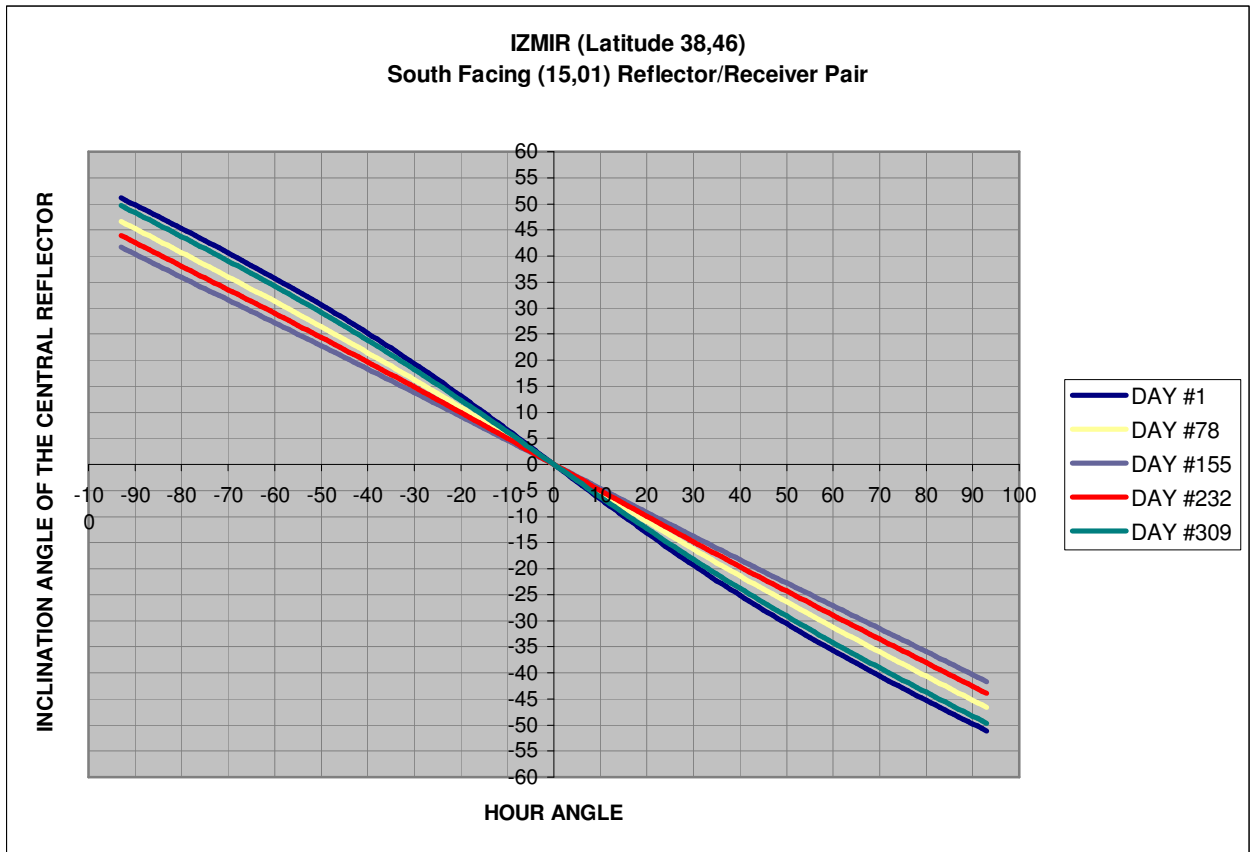

Figure 2.27 2D Graphic for South Facing (15.01°) Reflector-Receiver Pair

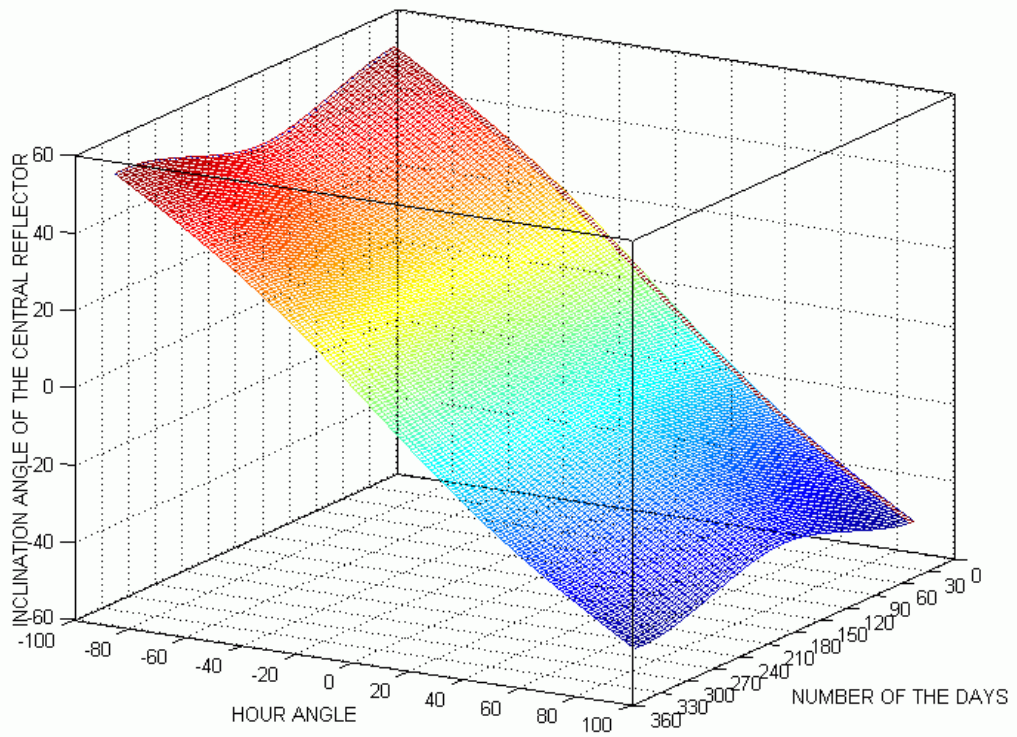

Figure 2.28. 3D Graphic for South Facing (15.01°) Reflector-Receiver Pair

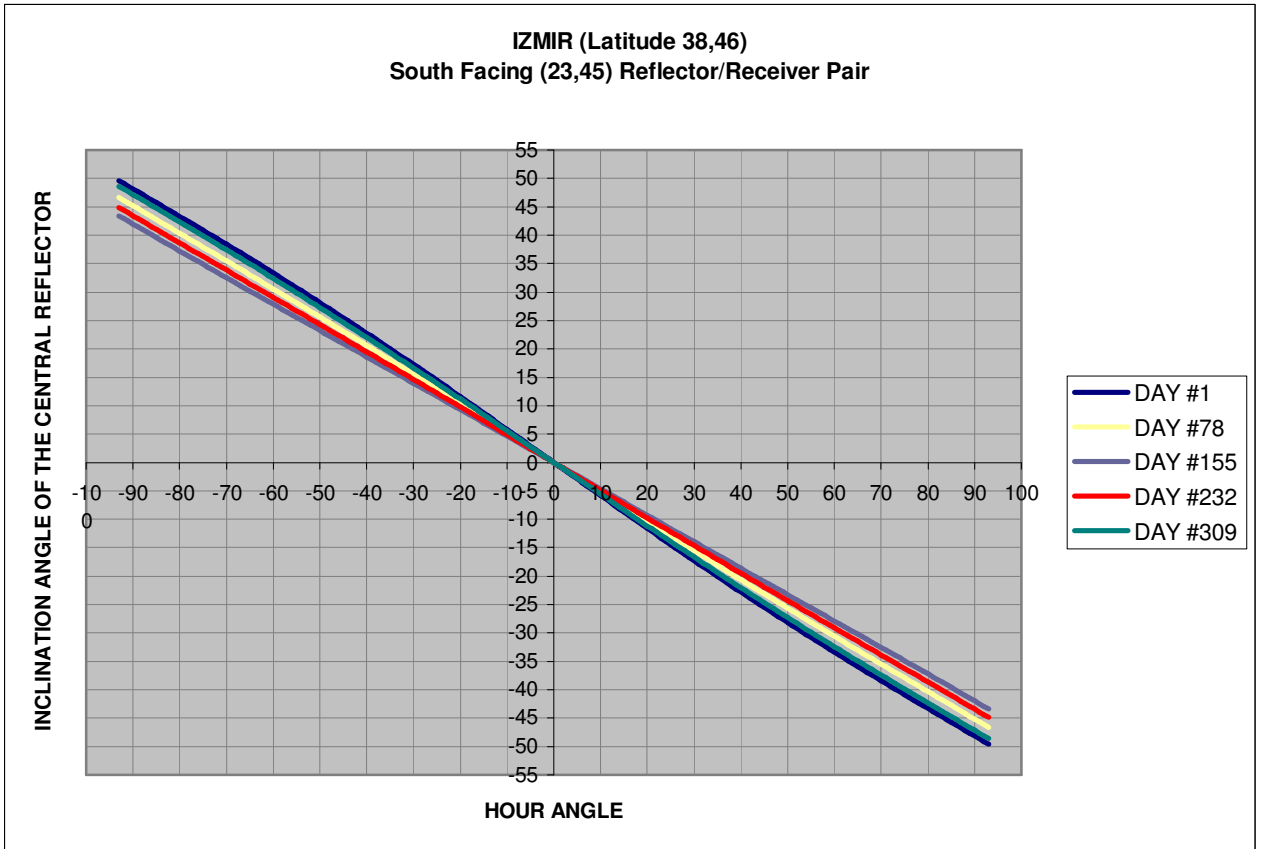

Figure 2.29. 2D Graphic for South Facing (23,45°) Reflector-Receiver Pair

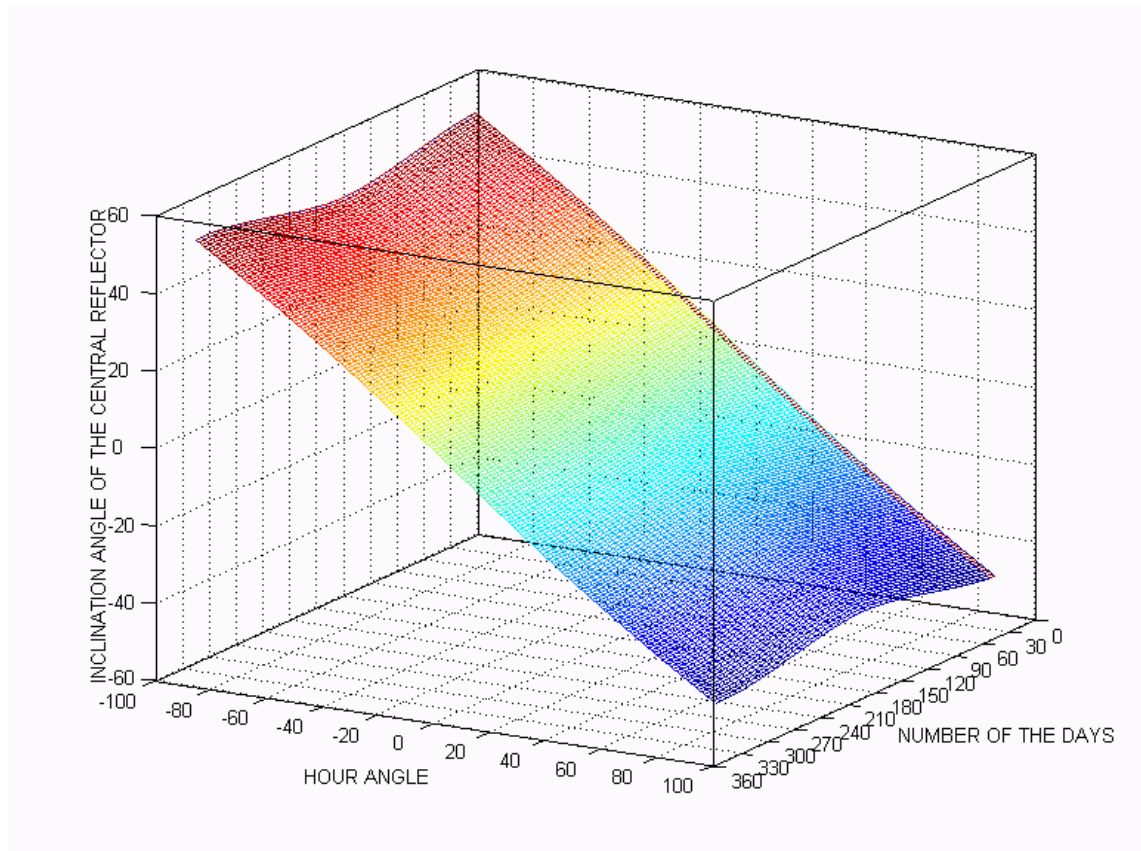

Figure 2.30. 3D Graphic for South Facing (23,45°) Reflector-Receiver Pair

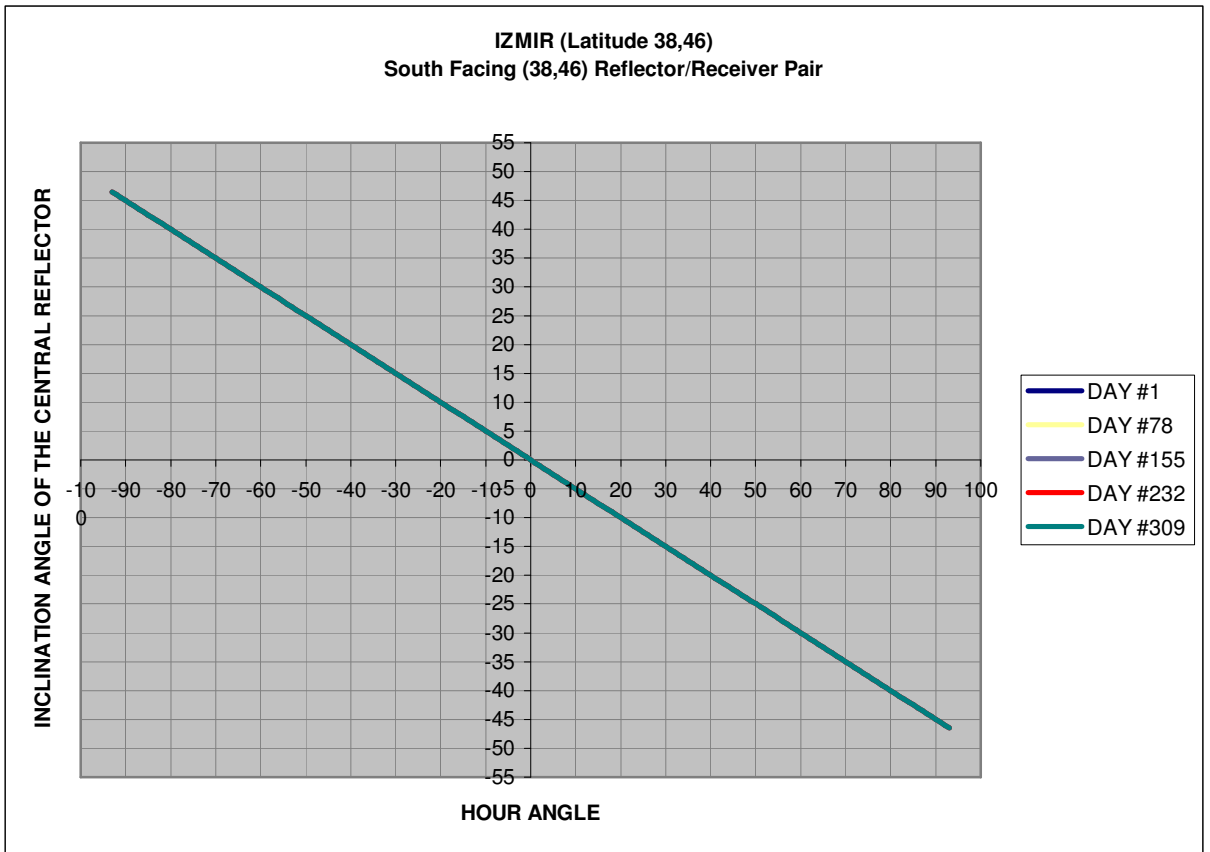

Figure 2.31. 2D Graphic for South Facing (38,46°) Reflector-Receiver Pair

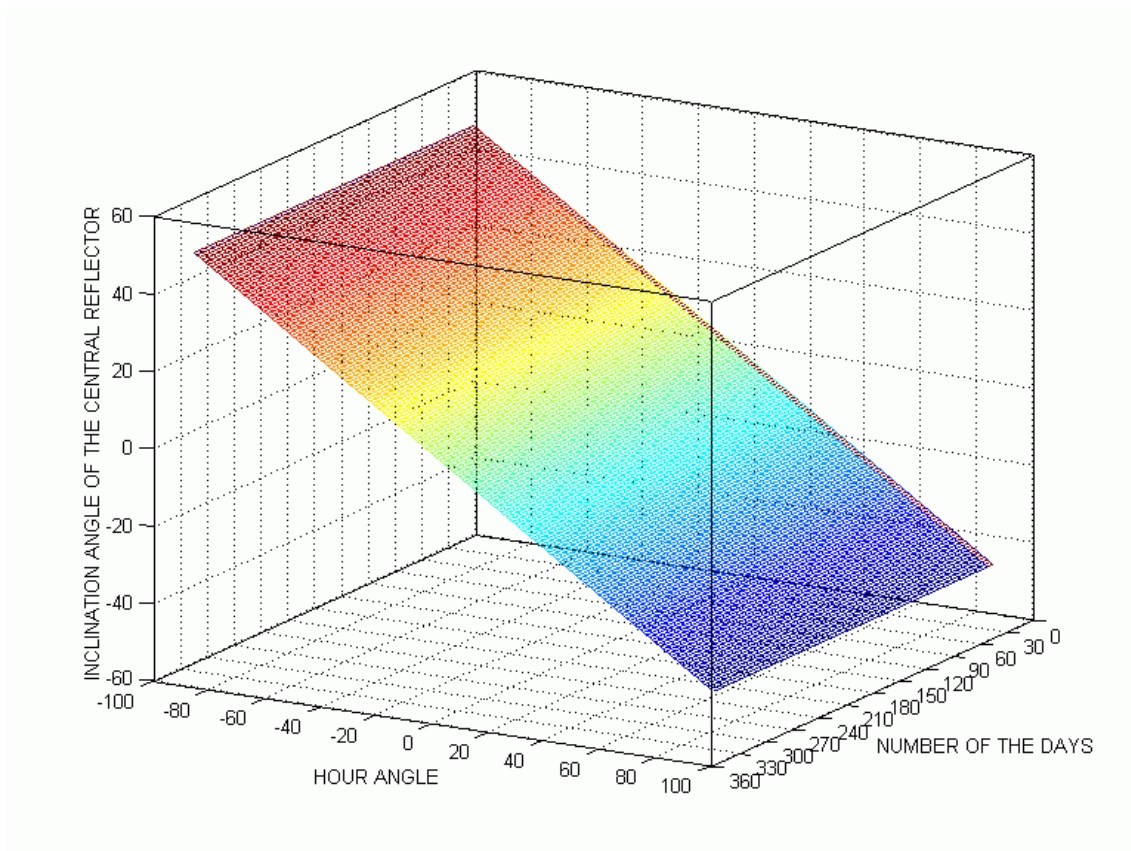

Figure 2.32. 3D Graphic for South Facing (38,46°) Reflector-Receiver Pair

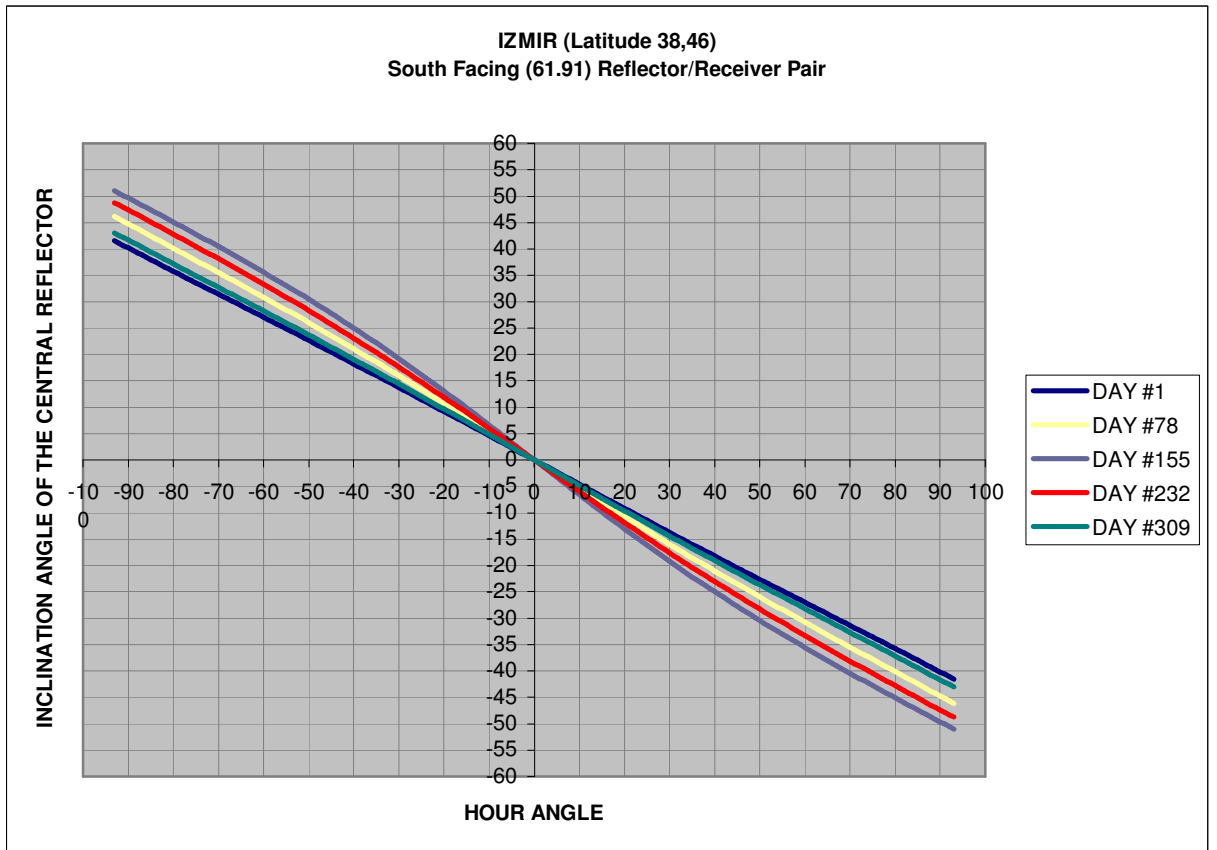

Figure 2.33. 2D Graphic for South Facing (61,91°) Reflector-Receiver Pair

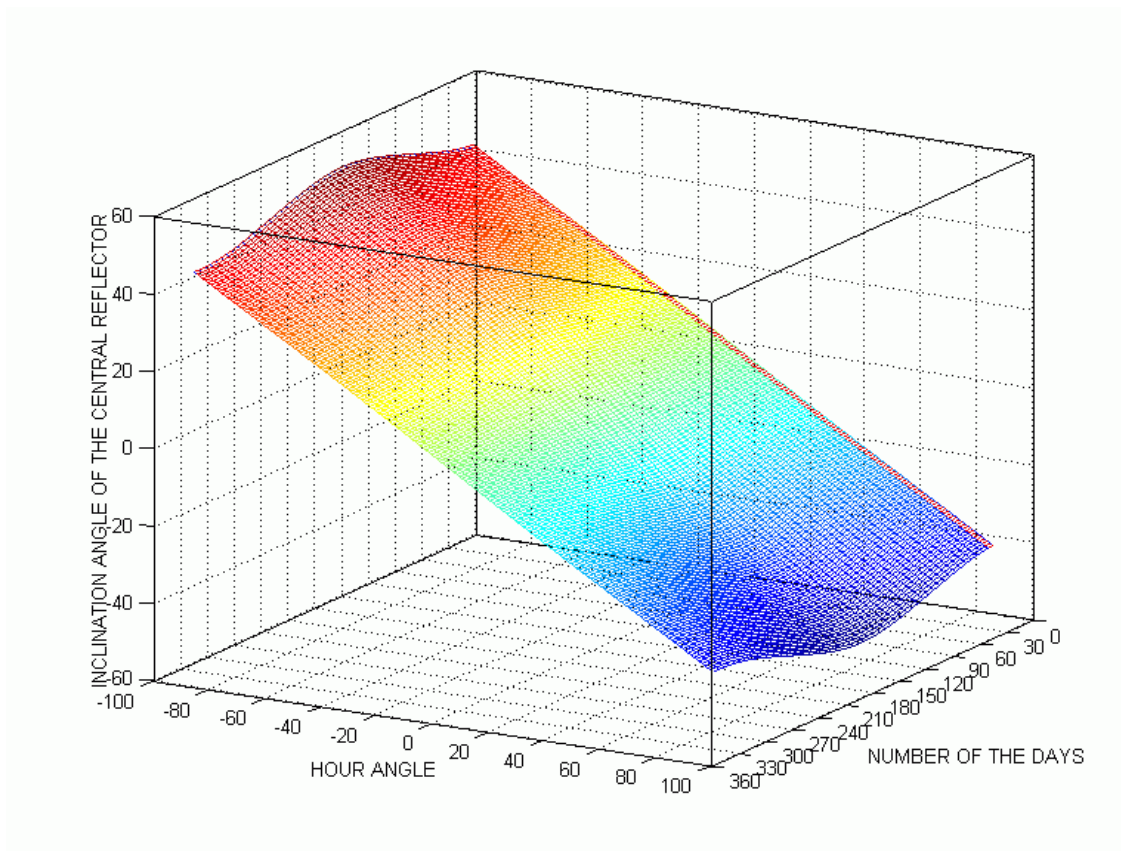
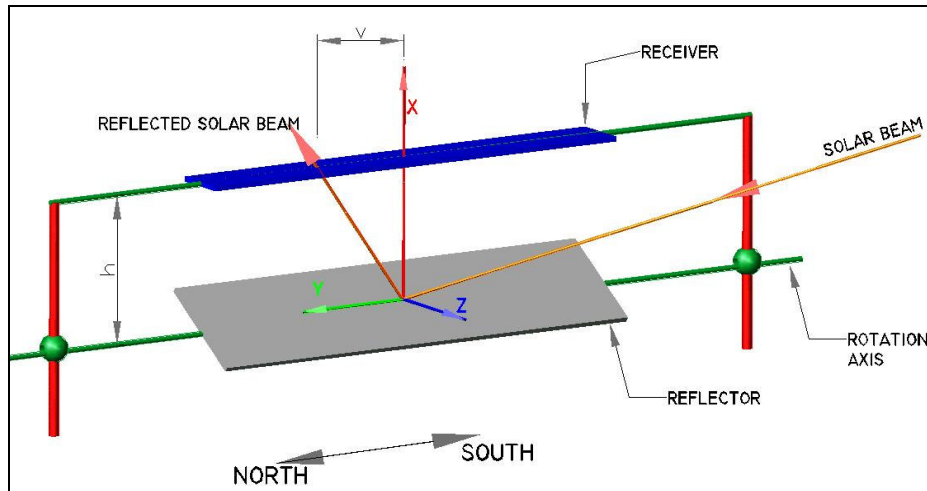

Figure 2.34. 3D Graphic for South Facing (61,91°) Reflector-Receiver Pair

v / h Ratio



(Figure 2.35.)

v / h RATIO FOR EAST-WEST ORIENTED SOUTH FACING REFLECTOR-RECEIVER PAIR	
$v / h = \frac{d}{p \cdot \cos 2\beta + 2 \cdot a \cdot \cos \beta \cdot \sin \beta}$	(2.27.)
$a = \cos \alpha \cdot \cos 23,45 \cdot \sin(\psi + \omega) - \sin \alpha \cdot \cos(\psi + \omega)$	(2.19.)
$d = \cos \alpha \cdot \cos 23,45 \cdot \cos(\psi + \omega) \cdot \sin(\phi + \mu) - \sin(\psi + \omega) \cdot \sin \alpha \cdot \sin(\phi + \mu) + \cos \alpha \cdot \sin 23,45 \cdot \cos(\phi + \mu)$	(2.28.)
$p = \cos \alpha \cdot \cos 23,45 \cdot \cos(\psi + \omega) \cdot \cos(\phi + \mu) - \sin(\psi + \omega) \cdot \sin \alpha \cdot \cos(\phi + \mu) - \cos \alpha \cdot \sin 23,45 \cdot \sin(\phi + \mu)$	(2.29.)
<p>α - DAY ANGLE $23,45$ - INCLINATION OF EARTH ψ - ANGLE TO FIND THE SOLAR NOON ω - HOUR ANGLE ϕ - LATITUDE μ - SOUTH FACING INCLINATION (EAST-WEST ROTATION AXIS) β - INCLINATION ANGLE OF CENTRAL REFLECTOR</p>	

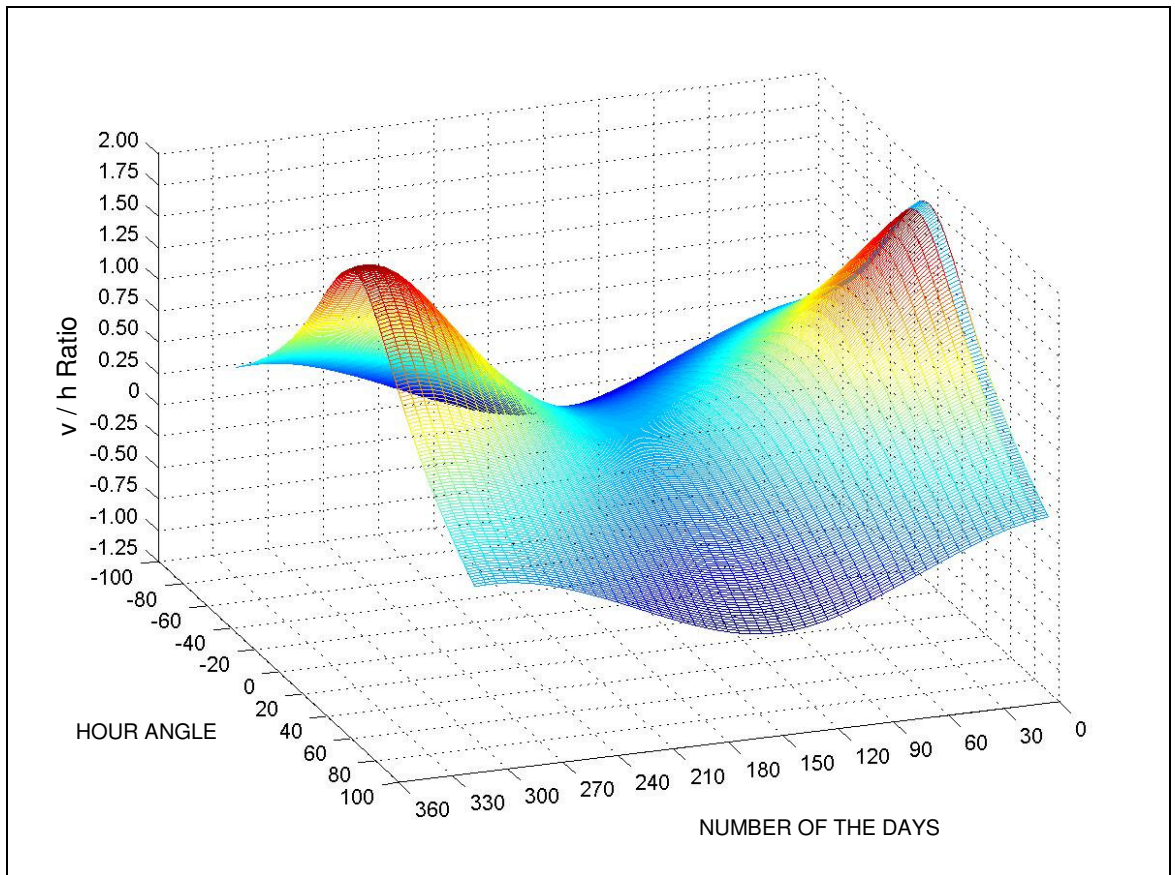
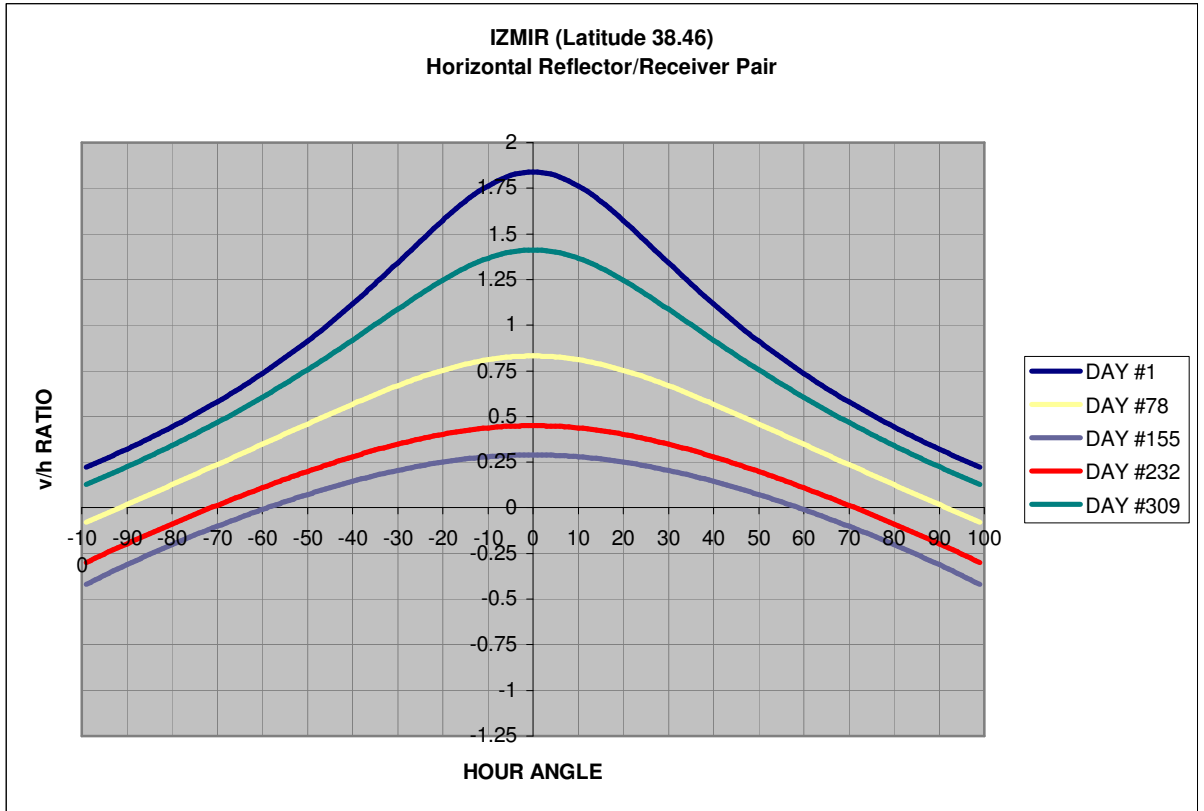

Figure 2.36. v / h Ratio Graphics for Horizontal Reflector-Receiver Pair

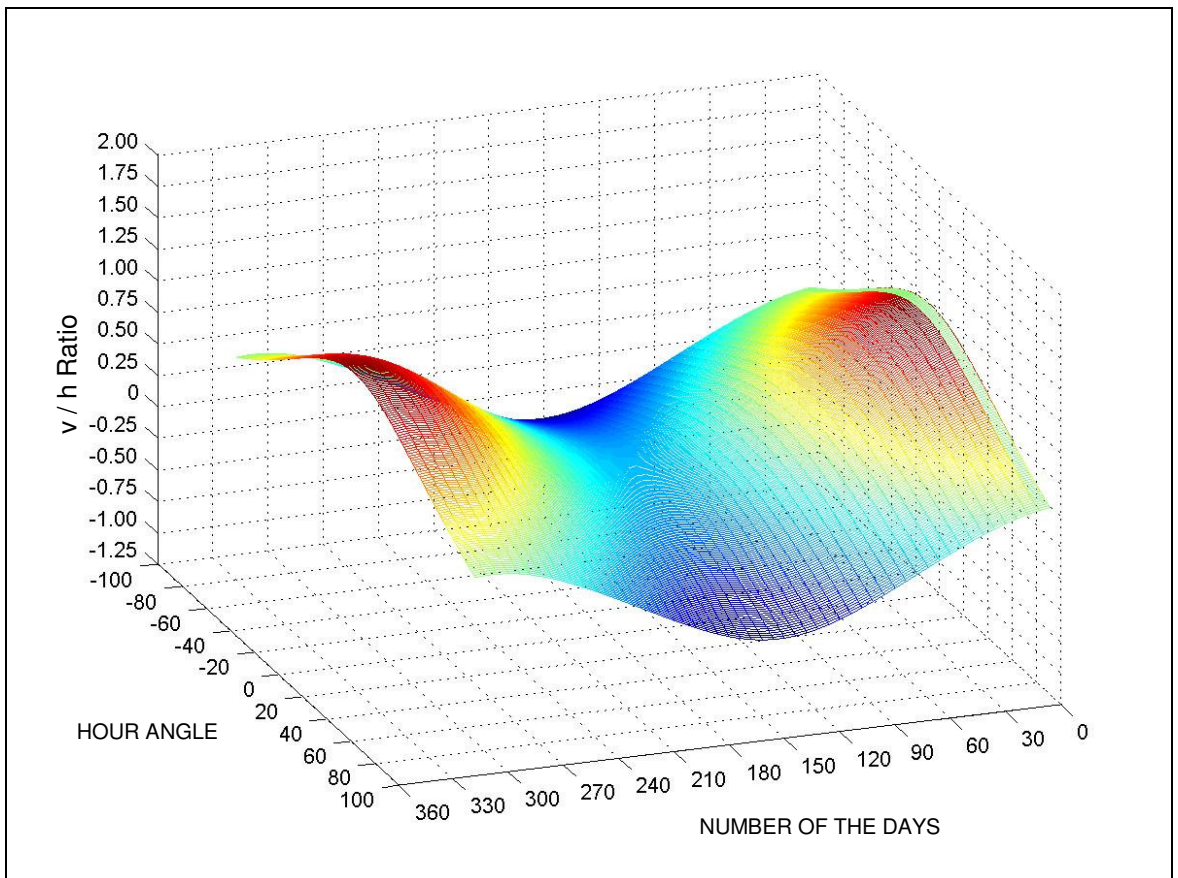
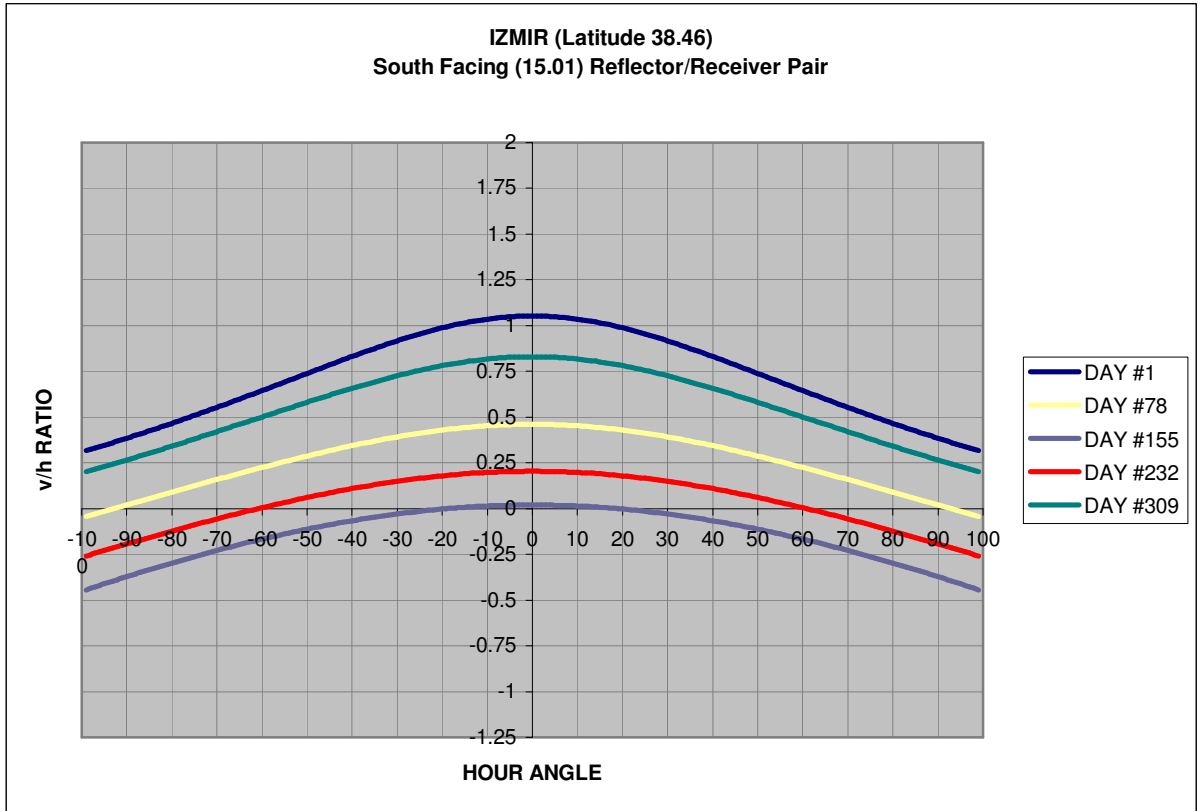

Figure 2.37. v/h Ratio Graphics for South Facing (15,01°) Reflector-Receiver Pair

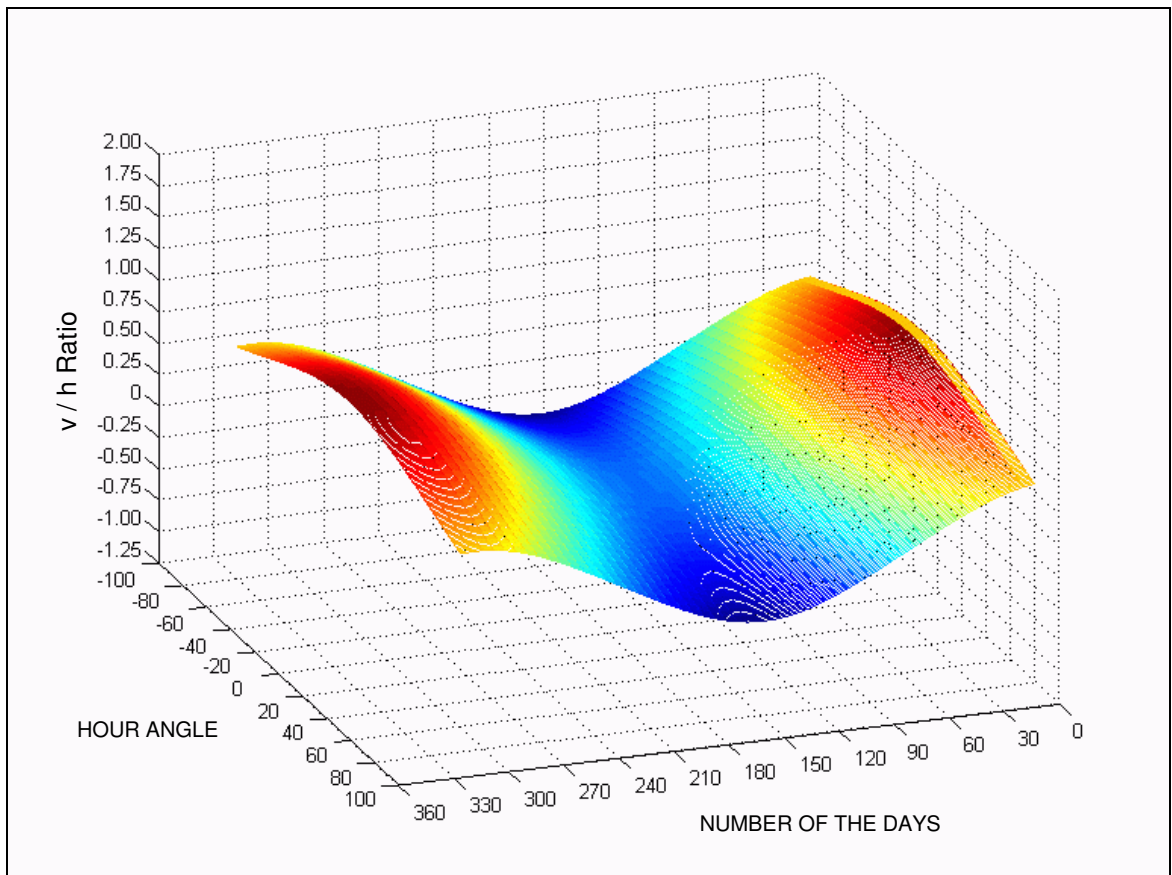
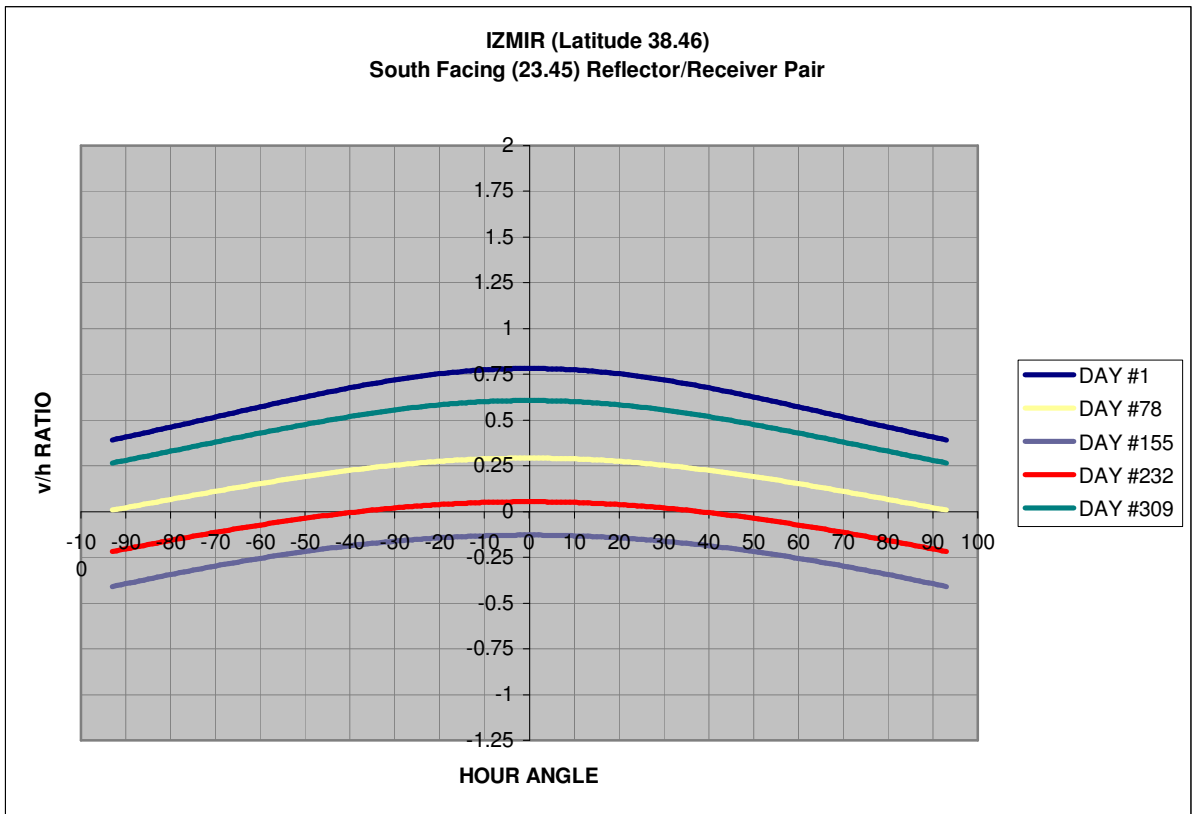

Figure 2.38. v/h Ratio Graphics for South Facing (23,45°) Reflector-Receiver Pair

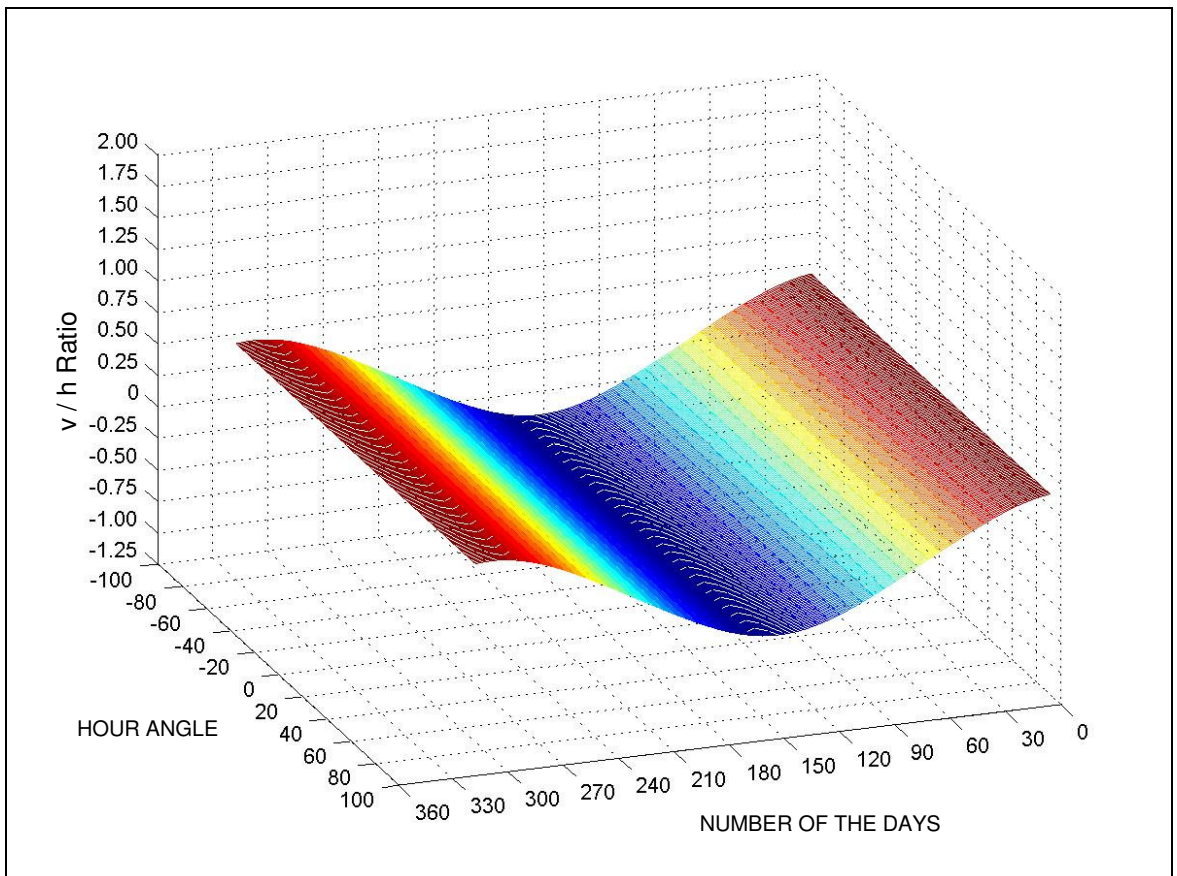
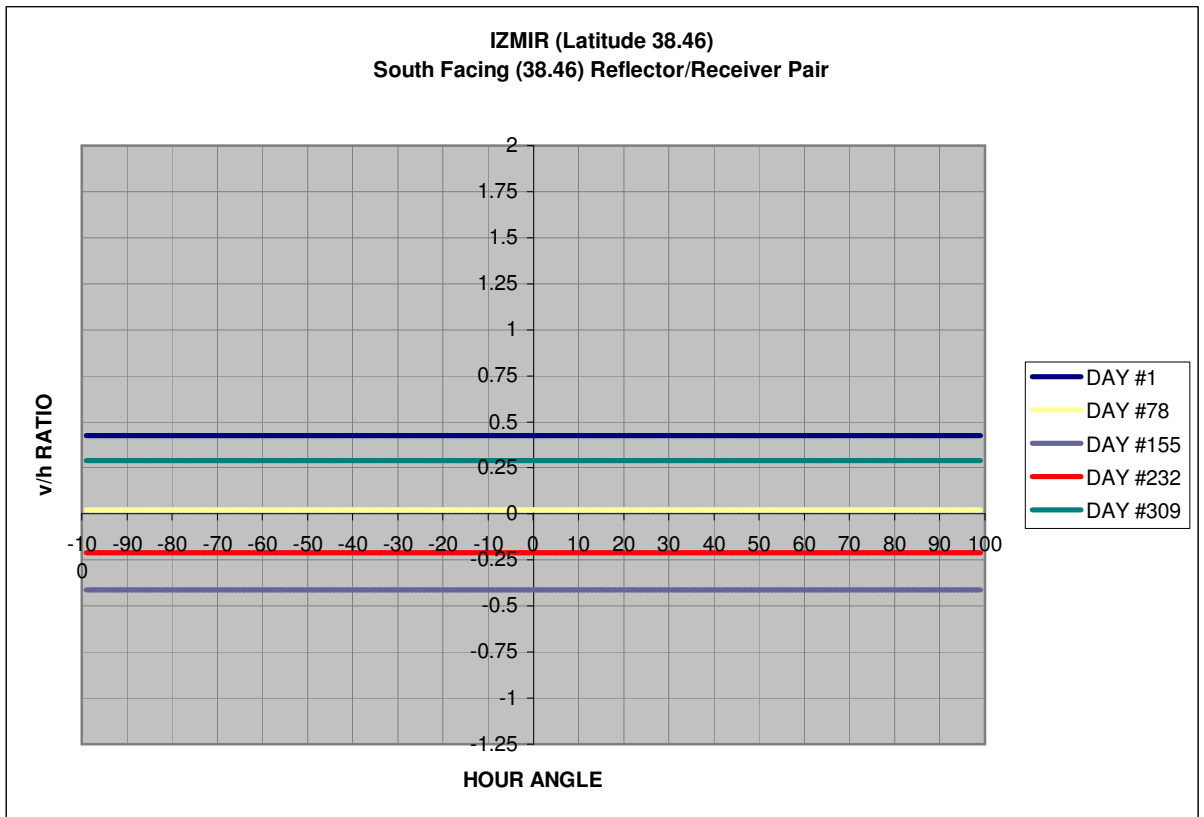

Figure 2.39. v/h Ratio Graphics for South Facing ($38,46^\circ$) Reflector-Receiver Pair

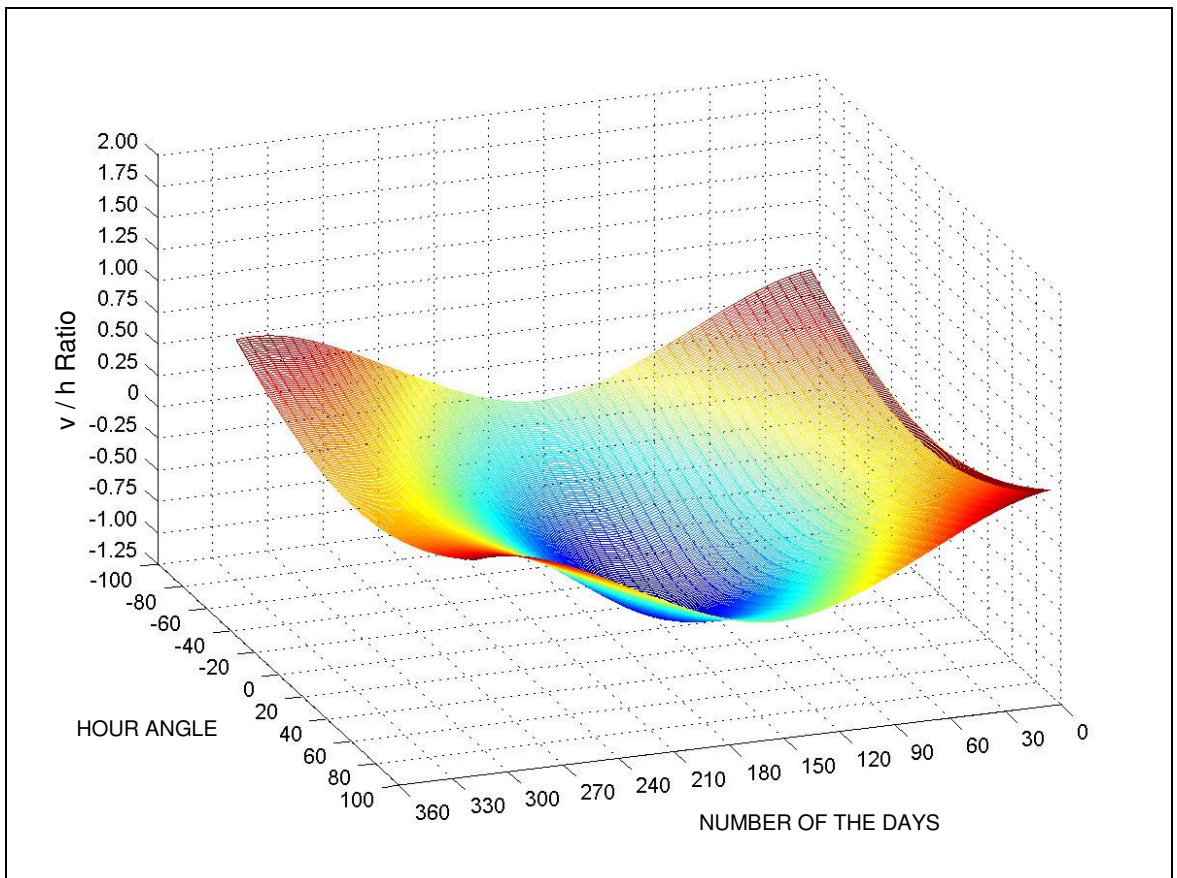
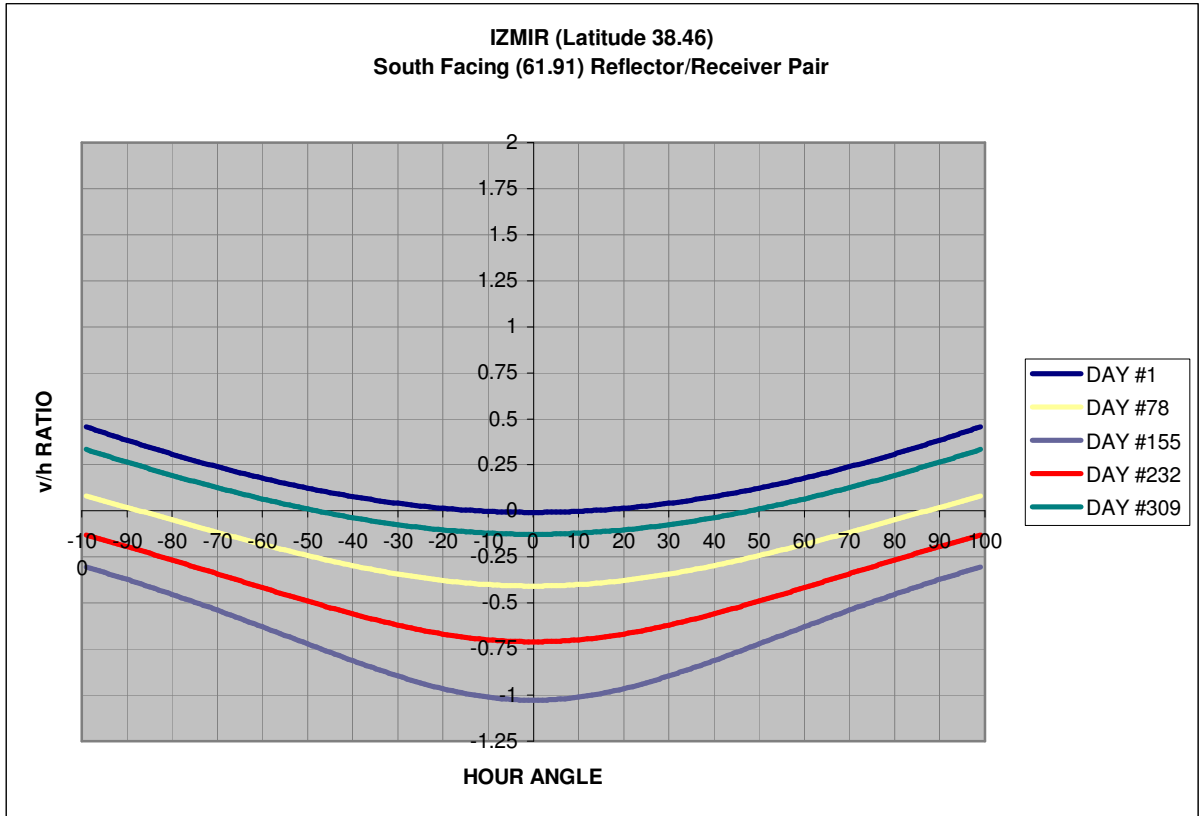

Figure 2.40. v/h Ratio Graphics for South Facing (61,91°) Reflector-Receiver Pair

CHAPTER 3

MULTI - REFLECTOR SYSTEM

3.1. Introduction

In previous chapter a "single reflector-single receiver pair" is investigated. Astronomical equations to define the inclination angle (β) are developed.

In this chapter study goes forward; a "multi reflector-single receiver" system is investigated. The planar reflectors are placed so, that their rotation axes are parallel in a virtual plane. All rotation axes are in the north-south direction and all the reflectors are reflecting the solar beams on a single receiver while they are rotating continuously on their own axes during the daytime. (Figure 3.1.)

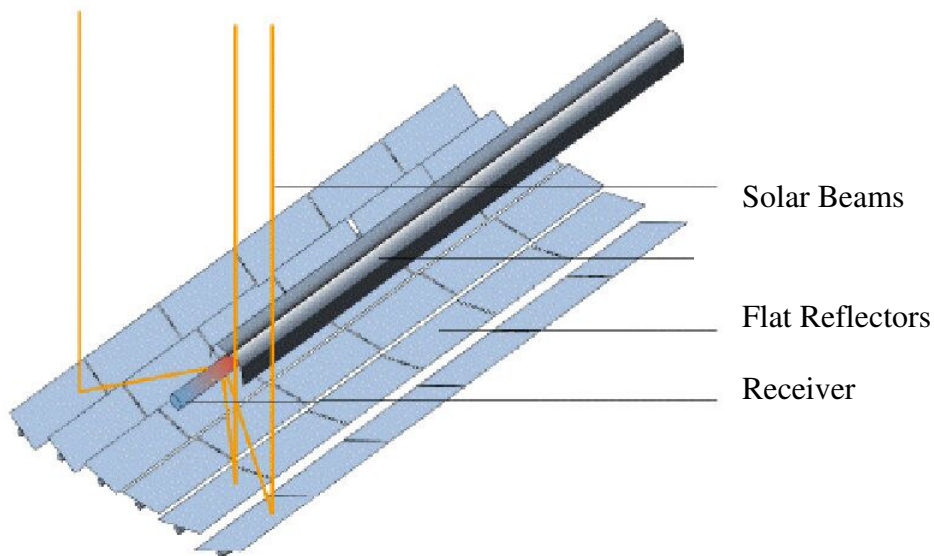

Figure 3.1. Multi Reflector System

Actually the multi-reflector system is the simulation of a PARABOLIC TROUGH. The reason to prefer the number of planar reflectors is their simple form causing to low cost.

3.2. Relative Movement of Reflectors

In (Figure 3.2.) there is shown a system with "single receiver and 2 reflectors". Once the reflectors are calibrated (positioned correctly) their relative rotation gets enough for the continuous focusing.

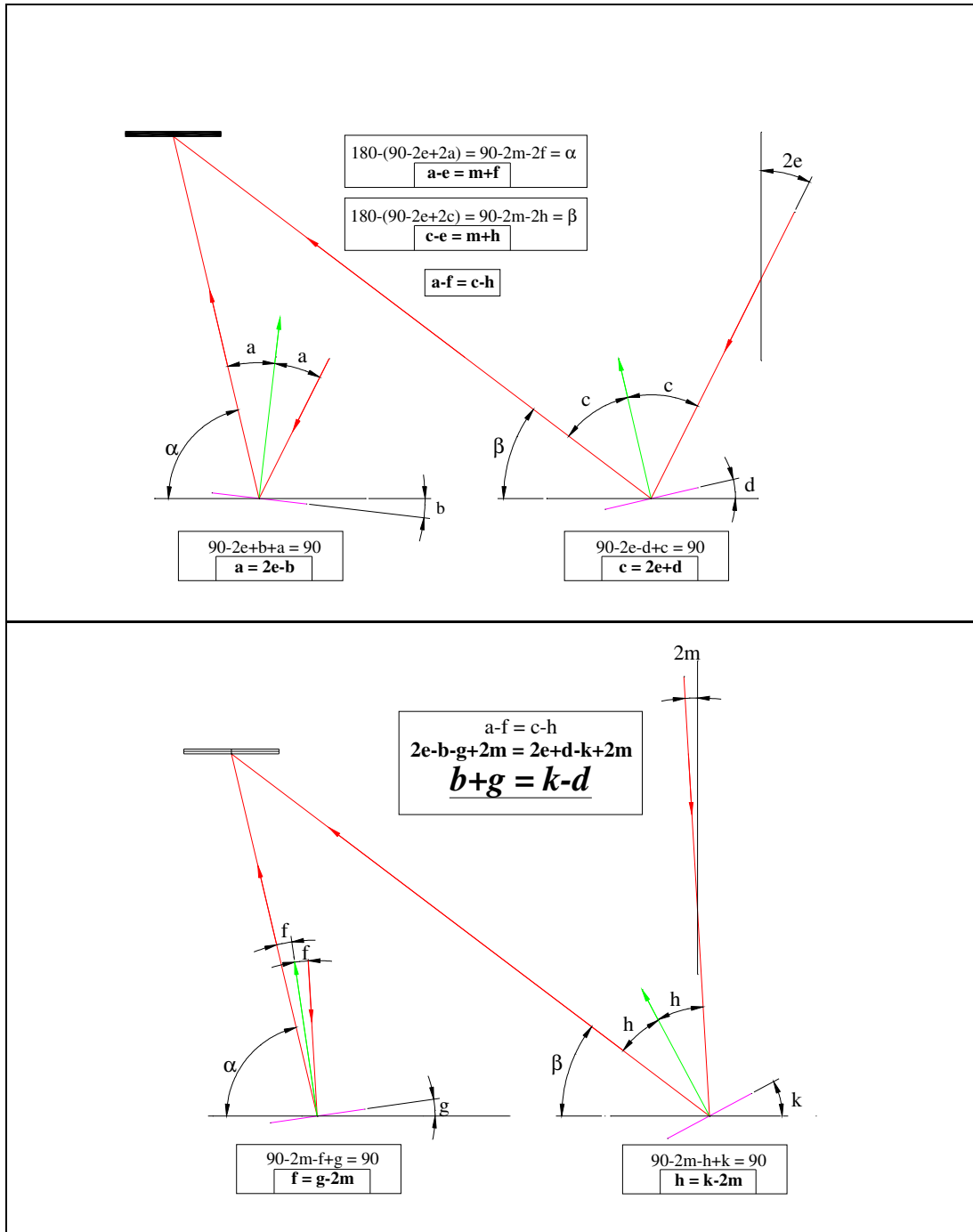

Figure 3.2. Relative Movement of Reflectors

(Figure 3.2.) shows 2 different solar incident angles $2e$ and $2m$. As the result; the angular difference of both reflectors is same. While the first reflector rotates $(b+g)^\circ$, the second one rotates $(k-d)^\circ$.

3.3. Fresnel Reflectors

3.3.1. Parabola Properties

A parabolic trough is simulated in order to define the dimensional properties and the placements of the planar reflectors. First of all, the focal length (c) of the parabolas is investigated. (Figure 3.3.)

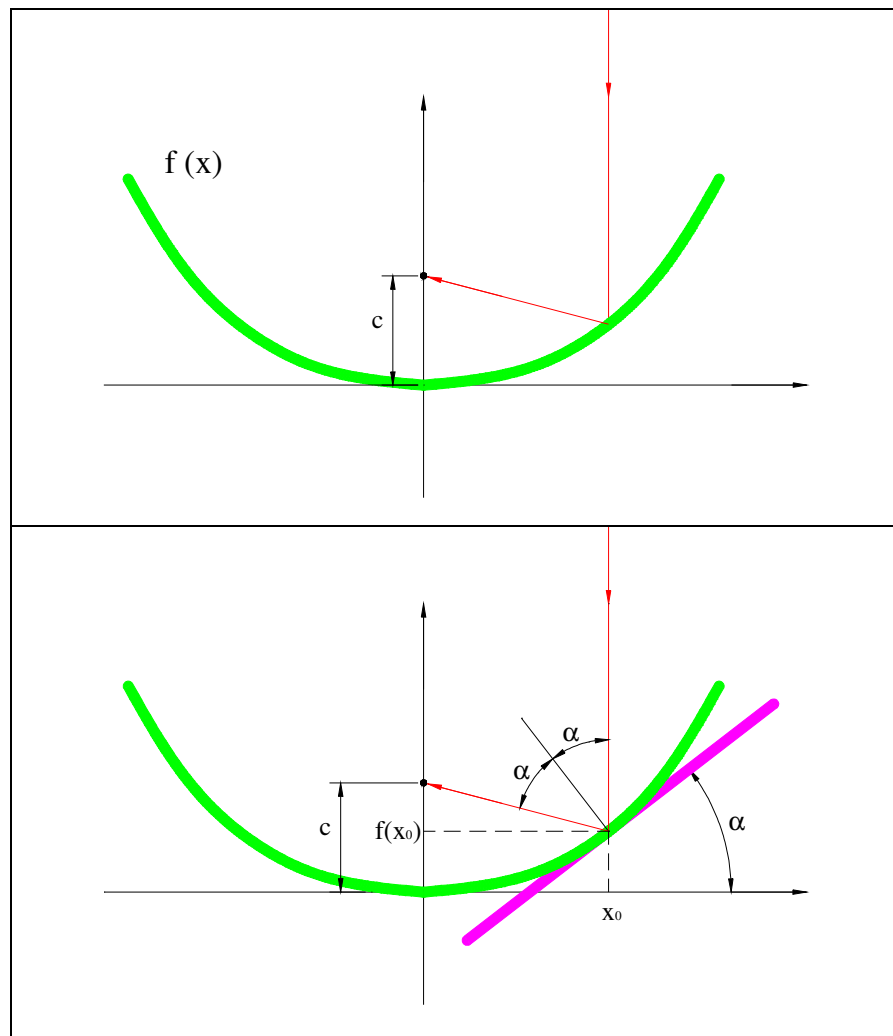

Figure 3.3. Focal Point of Parabol

$$c = f(x_0) + x_0 \cdot \tan\{90 - 2 \alpha\} \quad (3.1.)$$

$$\alpha = \arctan[f'(x_0)] \quad (3.2.)$$

$$c = f(x_0) + x_0 \cdot \tan\{90 - 2 \arctan[f'(x_0)]\} \quad (3.3.)$$

When the equations above are applied for some parabolas;

$$y = x^2 \quad ; \quad y' = 2x \quad ; \quad \text{for } x_0 = 1 \quad ; \quad c = 1+1 \cdot \tan[90-2 \cdot \arctan 2] = 0.25$$

$$y = 2x^2 \quad ; \quad y' = 4x \quad ; \quad \text{for } x_0 = 1 \quad ; \quad c = 2+1 \cdot \tan[90-2 \cdot \arctan 4] = 0.125$$

$$y = 4x^2 \quad ; \quad y' = 8x \quad ; \quad \text{for } x_0 = 1 \quad ; \quad c = 4+1 \cdot \tan[90-2 \cdot \arctan 8] = 0.0625$$

$$y = x^2/4 \quad ; \quad y' = x/2 \quad ; \quad \text{for } x_0 = 1 \quad ; \quad c = 1/4+1 \cdot \tan[90-2 \cdot \arctan 1/2] = 1$$

$$y = x^2/2 \quad ; \quad y' = x \quad ; \quad \text{for } x_0 = 1 \quad ; \quad c = 1/2+1 \cdot \tan[90-2 \cdot \arctan 1] = 0.5$$

as seen, the focal length (c) of the parabolas changes according to the coefficient in the equation. Variables x and y are in meters. But can be taken in millimeters when multiplied with 1000.

Determining the focal length is helpful while analyzing the structure of the system. As an example; if a system which's receiver is placed 1 meter above the reflectors is chosen, it can be sad that the $y=x^2/4$ parabola must be simulated. Or in other words $y=x^2/4000$ parabola when the lengths are taken in millimeters.

3.3.2. Simulation of a Parabola

Basic idea of the Fresnel Reflectors is to simulate a parabolic concentrator. In (Figure 3.4.) a parabolic concentrator is divided into pieces (Figure 3.5.). Every piece has a unique curve format and when each curved piece is replaced with a plane reflector, by which the plane is the tangent of the curve, a parabola like planar reflector with less focusing ability is obtained.

When the length of the planar reflectors shortens and the number of the reflectors increase the focusing ability increases. Such that infinite number of planes would create the original parabolic concentrator.

When the planar reflectors are translated to the horizontal plane in the direction of the reflected rays, reflectors placed side by side on the horizontal plane are achieved (Figure 3.6.). This design is called Fresnel Reflectors.

The horizontal space requirement of the design is more comparing parabolic reflector while vertical space requirement is less.

Figure3.4.
Parabolic Concentrator

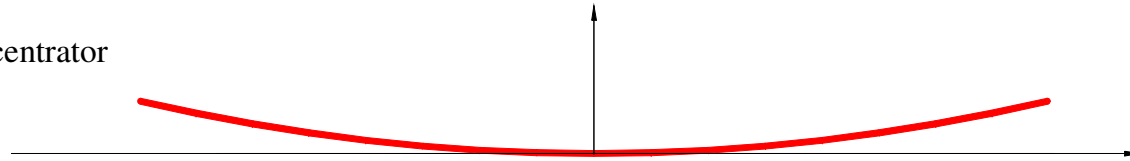

Figure3.5.
Model Parabolic Concentrator
as a series of
Flat Segments

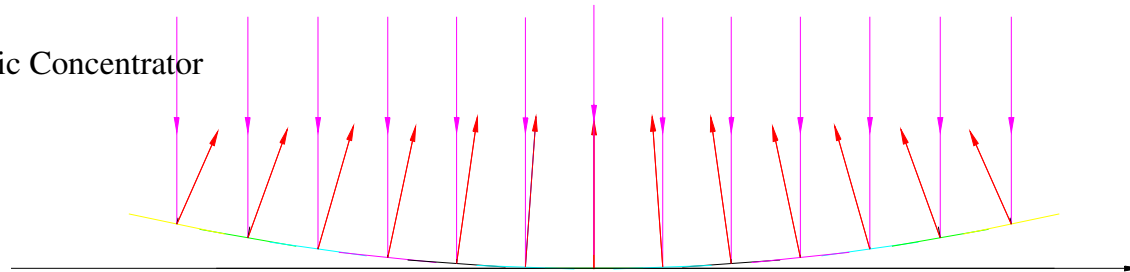
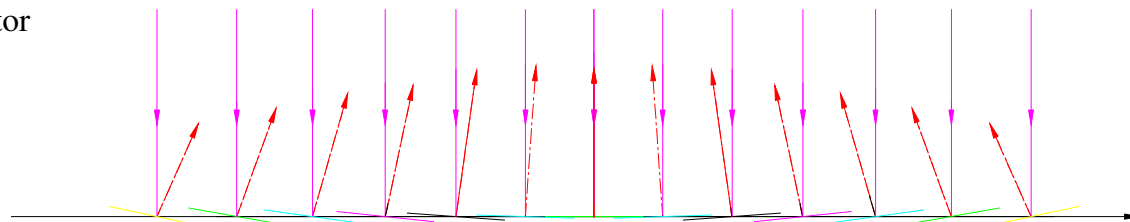

Figure3.6.
Fresnel Reflector



3.4. Model

As mentioned before parabola $y = x^2/4000$ should be modeled for the given focal length 1000 mm. When requested width of the model is 1000 mm. excess parts shown in (Figure 3.7) should be removed.

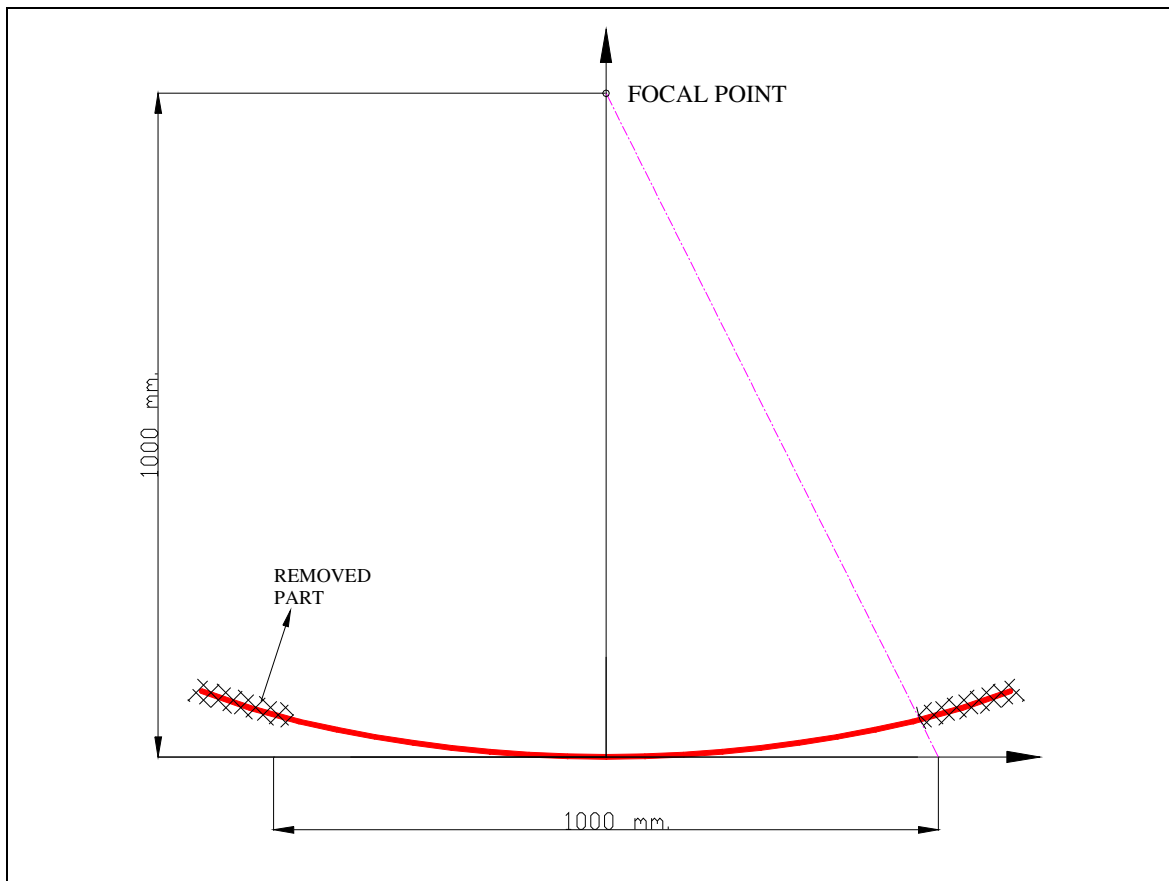

Figure 3.7. $y = x^2/4000$ Parabola

3.4.1. Limitations

During the manufacturing process of the model 3 limitations are encountered. When parabolic reflector is divided into planar reflectors;

1. The angle (β) between the horizontal plane and the reflectors
2. Reflector Lengths
3. Distance between the rotation axes of the reflectors.

are fractional numbers. These numbers should be modified for the ability of manufacture.

3.4.2. Line Equation for Reflected Beam

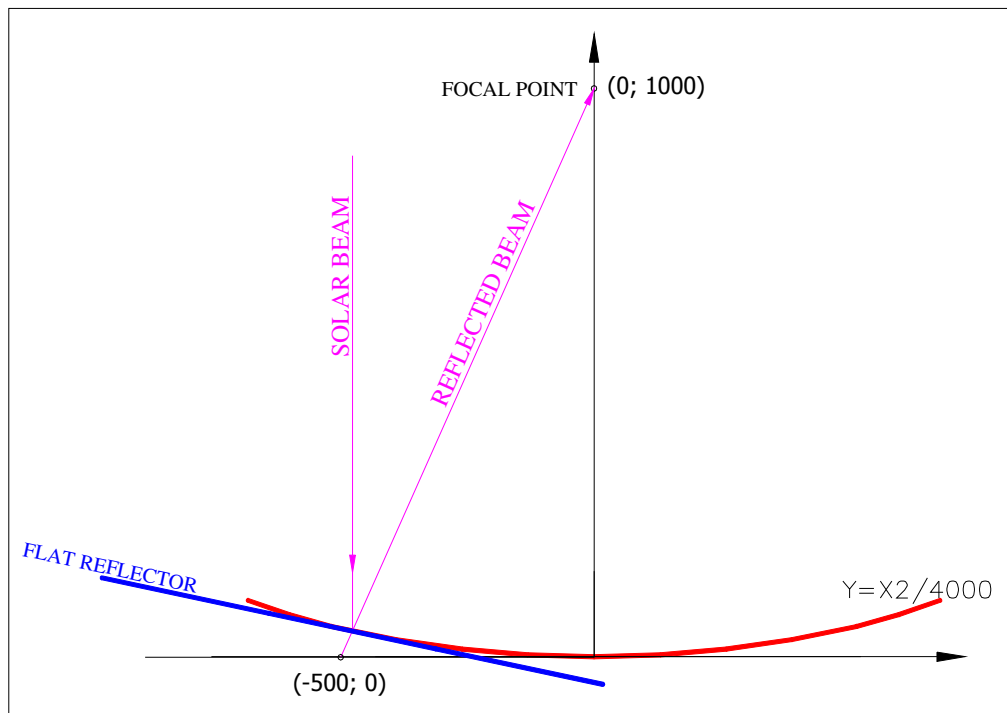

Figure 3.8. Line Equation for Reflected Beam

Line equation for reflected beam is

$$y = 2x + 1000 \quad (3.4.)$$

Intersection point of the line and the parabola is

$$2x + 1000 = x^2 / 4000 \quad (3.5.)$$

$$x = -472,136$$

3.4.3. Tangent of Parabola

The parabola tangent intersecting this point has a slope of;

$$\arctan (x / 2000) = \arctan (-472,136 / 2000) = -13,28^\circ \quad (3.6.)$$

Starting from 13° and inserting a flat reflector sloped $12^\circ, 11^\circ, 10^\circ, 9^\circ \dots -9^\circ, -10^\circ, -11^\circ, -12^\circ, -13^\circ$ a simulation of a parabola with 27 reflectors is created. Every reflectors slope decreases with one degree, which is suitable for manufacturing process.

Intersection point of the tangent -13° and parabola

$$\begin{aligned} \arctan(x / 2000) = -13^\circ &\longrightarrow x = -461,736 \\ y = x^2 / 4000 &\longrightarrow y = 53,300 \end{aligned}$$

3.4.4. Translating to the Horizontal Plane

Tangent with slope -13° should be translated to the x axis in the direction of the reflected beam. This line intersects the points (0; 1000) and (-461,736; 53,300). Equation of the line should be written and the intersection point at the x axis should be determined.

Equation of line when 2 points are known

$$\frac{x - x_0}{x_0 - x_1} = \frac{y - y_0}{y_0 - y_1} \Rightarrow \frac{x - 0}{0 + 461,736} = \frac{y - 1000}{1000 - 53,300}$$

(3.7.)

$$y = 2,050306x + 1000$$

$y=0$ is inserted

$$x = -487,732 \text{ mm.}$$

Tangent -13° passes through (-487,732; 0) point.

When the same calculations are repeated for the other reflectors (Table 3.1) is achieved.

3.4.5. Geometry of all Reflectors

Table 3.1. Geometry of all Reflectors

Tangent Slope	Intersection point of tangent and parabola		Intersection point of reflected beam line and x axis	
	x	y	x	y
13°	461.736	53.3	487.732	0
12°	425.113	45.18	445.228	0
11°	388.761	37.784	404.027	0
10°	352.654	31.091	363.97	0
9°	316.769	25.086	324.92	0
8°	281.082	19.752	286.746	0
7°	245.569	15.076	249.328	0
6°	210.208	11.047	212.556	0
5°	174.977	7.654	176.327	0
4°	139.854	4.89	140.541	0
3°	104.816	2.747	105.105	0
2°	69.842	1.219	69.927	0
1°	34.91	0.305	34.921	0
0°	0	0	0	0
-1°	-34.91	0.305	-34.921	0
-2°	-69.842	1.219	-69.927	0
-3°	-104.816	2.747	-105.105	0
-4°	-139.854	4.89	-140.541	0
-5°	-174.977	7.654	-176.327	0
-6°	-210.208	11.047	-212.556	0
-7°	-245.569	15.076	-249.328	0
-8°	-281.082	19.752	-286.746	0
-9°	-316.769	25.086	-324.92	0
-10°	-352.654	31.091	-363.97	0
-11°	-388.761	37.784	-404.027	0
-12°	-425.113	45.18	-445.228	0
-13°	-461.736	53.3	-487.732	0

3.4.6. Model Geometry

Rotation centers of the tangents intersecting the x axis is now determined. But these distances are not proper for manufacturing process. The distance between 2 consecutive reflectors is shown at (Table 3.2.). In the table, modified (converted to integer) distances are also shown.

Table 3.2. Model Geometry

Slope	Distance of Rotation Centers from the Origin	Distance between 2 Consecutive Rotation Centers	MODIFIED Distance of Rotation Centers from the Origin	MODIFIED Distance between 2 Consecutive Rotation Centers
13°	487.732		485	
		42.504		40
12°	445.228		445	
		41.202		40
11°	404.027		405	
		40.057		40
10°	363.97		365	
		39.05		40
9°	324.92		325	
		38.174		40
8°	286.746		285	
		37.418		40
7°	249.328		245	
		36.772		35
6°	212.556		210	
		36.23		35
5°	176.327		175	
		35.785		35
4°	140.541		140	
		35.437		35
3°	105.105		105	
		35.177		35
2°	69.927		70	
		35.007		35
1°	34.921		35	
		34.921		35
0°	0		0	

Modified distances are preferred for simplicity at manufacturing. Standardizing and reducing reflector types, decrease manufacturing costs.

It has become easier to determine the reflector widths according to the established distances between the rotation centers. Reflector widths are chosen considering center distances. (Table 3.3)

Table 3.3. Calibration Angles

Slope	ReflectorWidth
$\pm 13^\circ$	38
$\pm 12^\circ$	38
$\pm 11^\circ$	38
$\pm 10^\circ$	38
$\pm 9^\circ$	38
$\pm 8^\circ$	38
$\pm 7^\circ$	32
$\pm 6^\circ$	32
$\pm 5^\circ$	32
$\pm 4^\circ$	32
$\pm 3^\circ$	32
$\pm 2^\circ$	32
$\pm 1^\circ$	32
0°	32

3.5. Chapter 3 Summary

When parabolic reflector $y = x^2 / 4000$ is directly used into the model solar beams are focused on a single line. (Figure 3.9.)

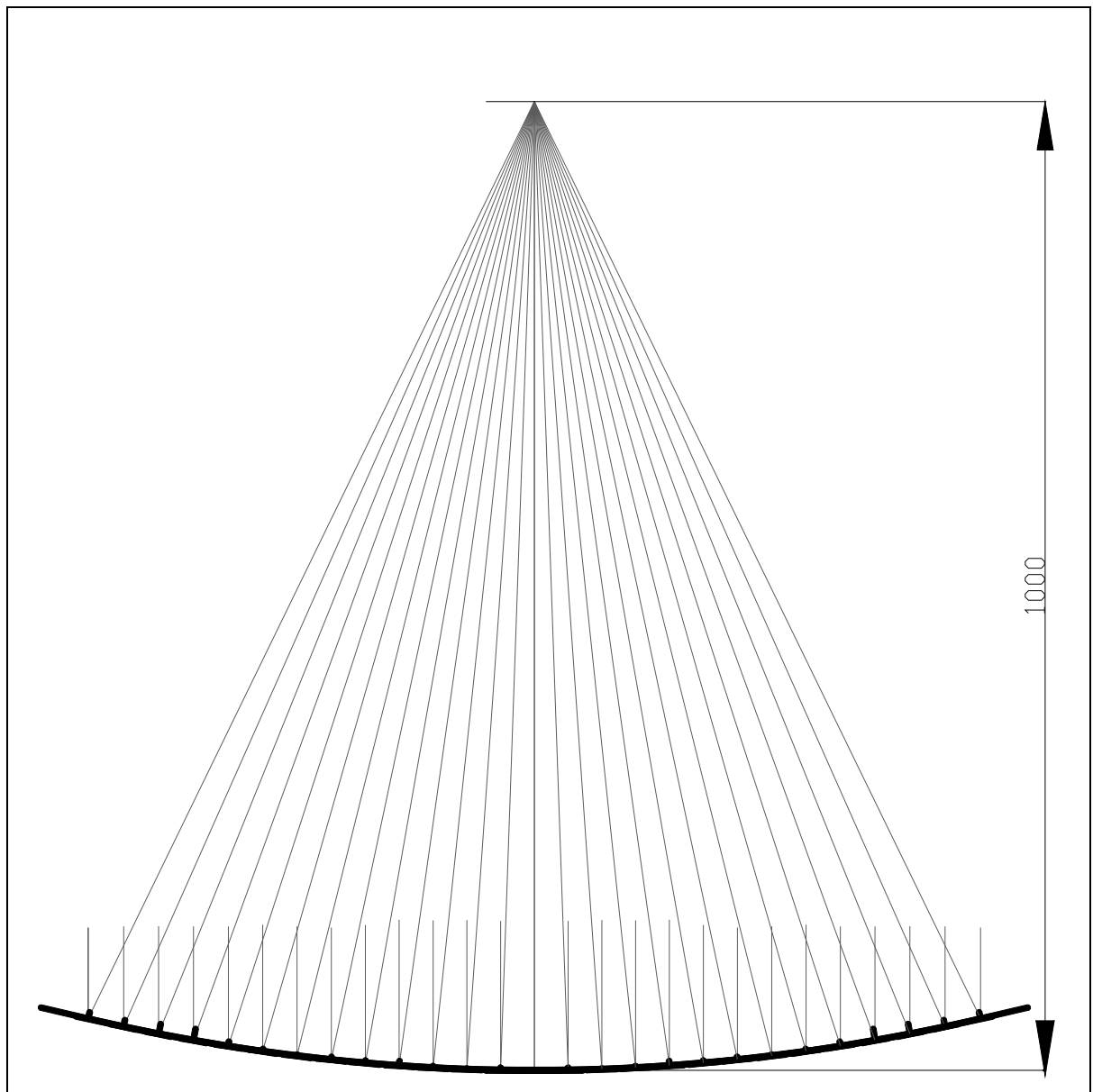

Figure 3.9. $y = x^2 / 4000$ Parabola / SOLAR TIME ($\omega = 0$)

But the concentrating ratio decreases during the simulation of the parabola with flat reflector segments (Figure 3.10.). This design is known as FRESNEL REFLECTOR. In case of using a Fresnel Reflector solar beams focus on a plane.

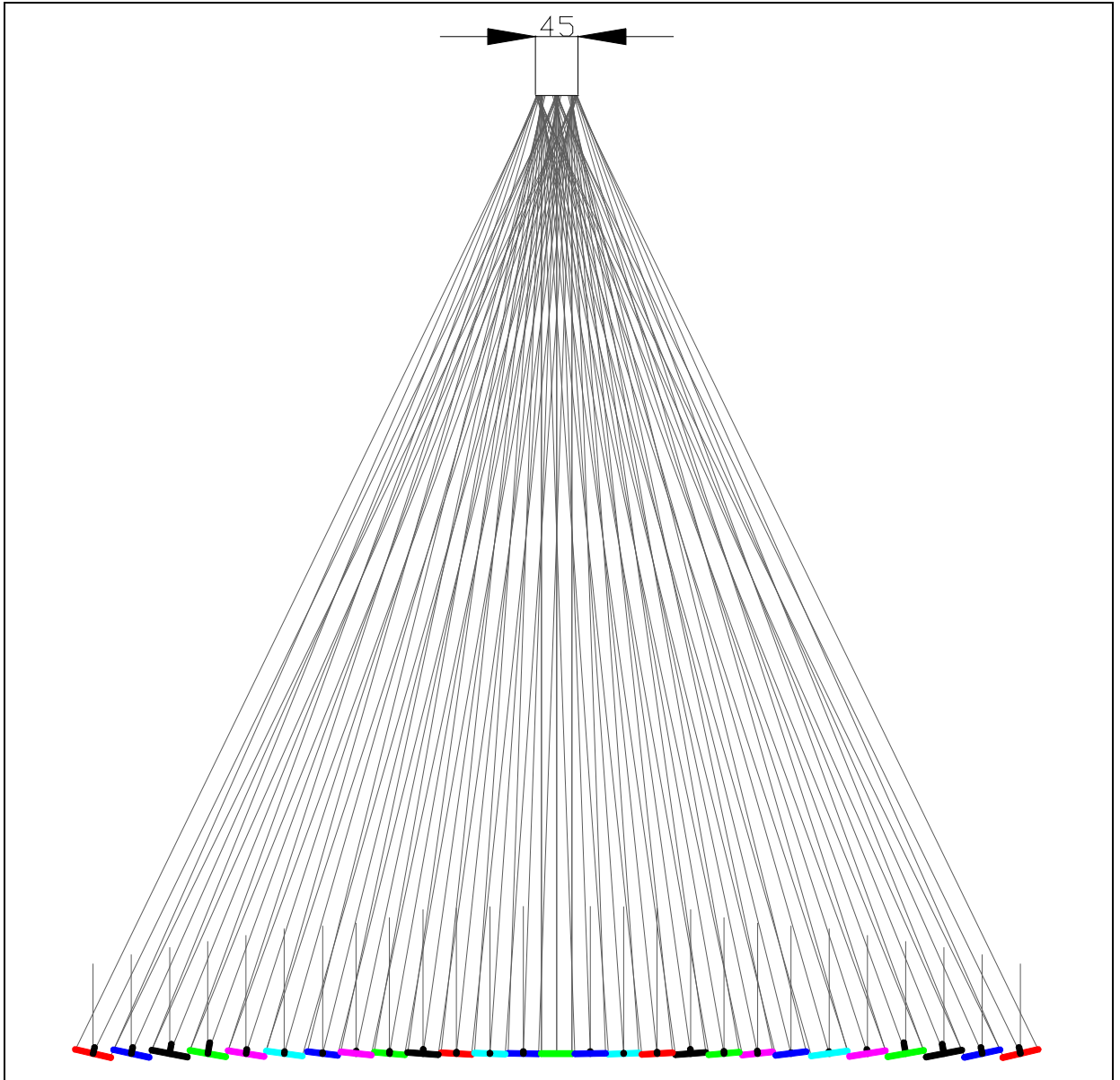

Figure 3.10. Simulation of $y = x^2 / 4000$ Parabola / SOLAR NOON ($\omega = 0$)

In (Figure 3.11.) and (Figure 3.12.) simulation of the $y = x^2 / 4000$ parabola is shown for different times of the day.

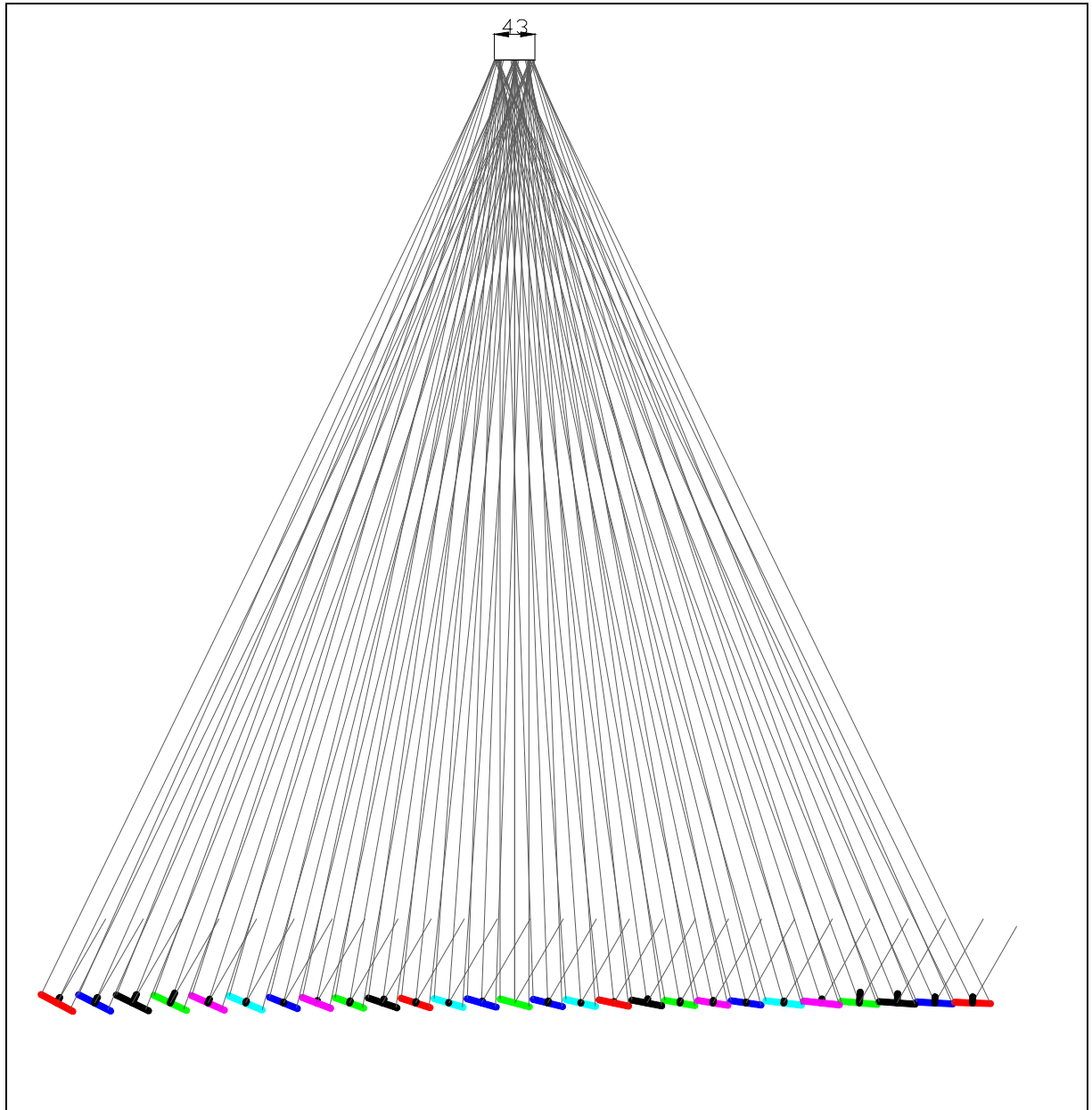

Figure 3.11. Simulation of $y = x^2 / 4000$ Parabola / SOLAR TIME ($\omega = 30$)

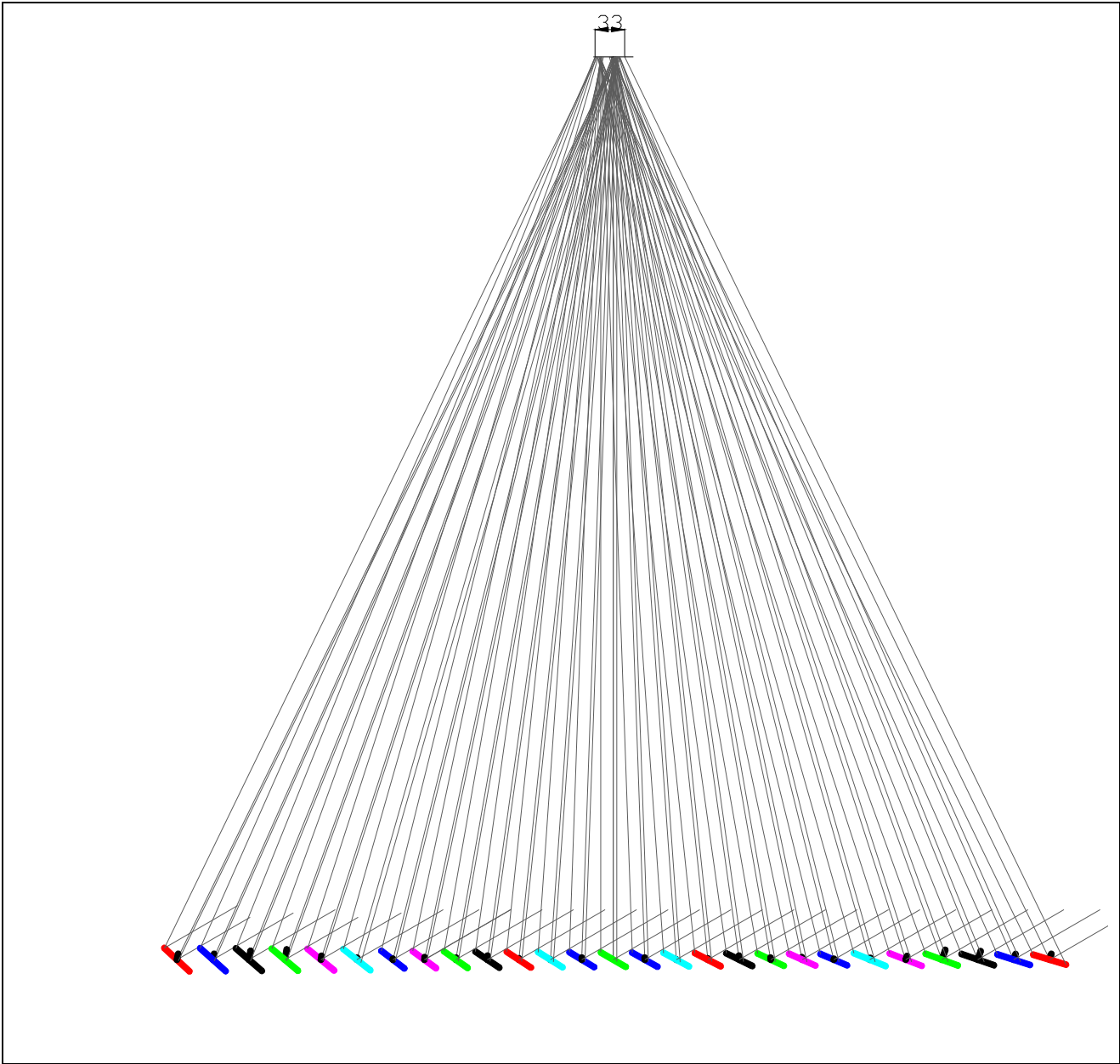

Figure 3.12. Simulation of $y = x^2 / 4000$ Parabola / SOLAR TIME ($\omega = 60$)

CHAPTER 4

SOLAR ENERGY COLLECTION

4.1. Introduction

Overshadowing is one important problem that we encounter in studying Fresnel Reflectors. Each reflector with different inclination angle is shaded in different amounts. It seems difficult to calculate the instant solar energy that the reflectors can reflect.

Considering system costs, when the reflector area increases;

- cost of reflectors
- cost of supporting system that carries the reflectors
- cost and power of the system that orients reflectors

Increase.

Land costs are also effective in the decisions. Also by means of making good use of the hours close to solar noon, reflector groups lined as tight as possible should be considered.

4.2. Extraterrestrial Solar Radiation

Sun is approximately $1,495 \cdot 10^{11}$ m. far from earth. If there is not an atmosphere around the earth, on average 1353 W/m^2 solar energy would be landed on a place which the solar beams are perpendicular. An imaginary plane outside the atmosphere would collect same amount of energy and this radiation is called **Extraterrestrial Radiation**.

The value of extraterrestrial radiation varies in a year depending on the changing distance between sun and earth.

$$I_{on}^* = I_o^*(1+0,033 \cdot \cos(360 \cdot n/365)) \text{ (W/m}^2\text{)} \quad (4.1.)$$

(Equation 4.1.) gives the amount of extraterrestrial solar radiation for the n^{th} day of the year. "n" is the number of the day.

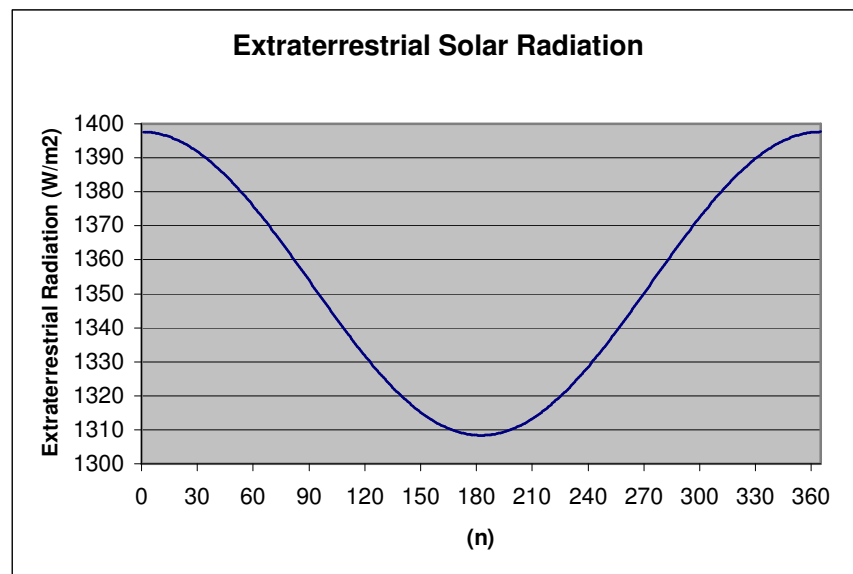

Figure 4.1. Extraterrestrial Solar Radiation

Extraterrestrial solar radiation depending on the day of the year is shown in (Figure 4.1.). The earth's closest approach to the sun occurs around January 4th and it is furthest from the sun around July 5th.

4.3. Solar Incident Angle (θ)

Sunlight reaching the earth surface, which is unmodified by any atmospheric processes, is termed beam or direct radiation. It is the type of sunlight that casts a sharp shadow, and on a sunny day it can be as much as 80 percent of the total sunlight striking a surface. Hence, beam or direct radiation is the most important type of radiation for solar processes.

The second type of solar radiation is diffuse or scattered sunlight. This is such sunlight that comes from all directions in the sky dome other than the direction of the sun. It is the sunlight scattered by atmospheric components such as particles, water vapor, and aerosols. On a cloudy day, the sunlight is 100 percent diffuse.

The amount of direct radiation on a horizontal surface can be calculated by multiplying the direct normal irradiance times the cosine of the zenith angle. Solar incident angle can be calculated by (Atagündüz, 1989)

$$\begin{aligned} \cos\theta = & (\sin\delta \cdot \sin\phi \cdot \cos\mu) - (\sin\delta \cdot \cos\phi \cdot \sin\mu \cdot \cos\gamma) + (\cos\delta \cdot \cos\phi \cdot \cos\mu \cdot \cos\omega) \\ & + (\cos\delta \cdot \sin\phi \cdot \sin\mu \cdot \cos\gamma \cdot \cos\omega) + (\cos\delta \cdot \sin\mu \cdot \sin\gamma \cdot \sin\omega) \end{aligned} \quad (4.2.)$$

θ : Solar Incident Angle

Angle between the inclined surface normal and the solar beam.

δ : Declination Angle

It is the angle between a plane perpendicular to a line between the earth and the sun and the earth's axis. It changes between $-23,45^\circ < \delta < 23,45^\circ$. An approximate formula for the declination of the sun is $\delta = 23,45 \cdot \sin(360 \cdot (284+n)/365)$

μ : South Facing Inclination angle of the plane. $0^\circ < \mu < 180^\circ$

γ : Surface Azimuth

Angle between the projection of plane's normal and the north-south axis.

For the south facing surface $\gamma = 0$. From south to north over east it is signed (-) and from south to north over west it is signed (+)

ω : Hour Angle

ϕ : Latitude Angle

4.3.1. Solar Incident Angle for North-South Oriented Plane

Surface azimuth (γ) for the horizontal plane which is oriented only about the rotation axis in the north-south direction, can be $+90^\circ$ or 0° or -90° . That means, the projection of surface normal is even in west or east direction. According to the definition of surface azimuth;

- For east looking surface $\gamma = -90^\circ$
- For west looking surface $\gamma = +90^\circ$

In this case (Equation 4.2) can be reduced in 3 simple form

➤ For the (-) values of ω (before solar noon) $\gamma = -90^\circ$

$$\cos\theta = \sin\delta \cdot \sin\phi \cdot \cos\mu + \cos\delta \cdot \cos\phi \cdot \cos\mu \cdot \cos\omega - \cos\delta \cdot \sin\mu \cdot \sin\omega \quad (4.3.)$$

➤ For the (+) values of ω (after solar noon) $\gamma = +90^\circ$

$$\cos\theta = \sin\delta \cdot \sin\phi \cdot \cos\mu + \cos\delta \cdot \cos\phi \cdot \cos\mu \cdot \cos\omega + \cos\delta \cdot \sin\mu \cdot \sin\omega \quad (4.4.)$$

➤ For the zero value of ω (solar noon) $\gamma = 0^\circ$

$$\begin{aligned} \cos\theta = \sin\delta \cdot \sin\phi \cdot \cos\mu - \sin\delta \cdot \cos\phi \cdot \sin\mu + \cos\delta \cdot \cos\phi \cdot \cos\mu \cdot \cos\omega \\ + \cos\delta \cdot \sin\phi \cdot \sin\mu \cdot \cos\omega \end{aligned} \quad (4.5.)$$

4.4. Extraterrestrial Solar Radiation for the Inclined Plane

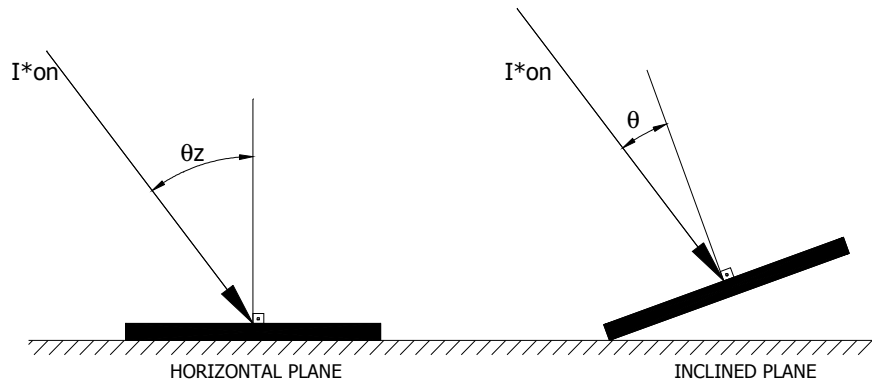

Figure 4.2. Extraterrestrial Solar Radiation for the Inclined Plane

(Figure 4.2.) shows 2 planes one is horizontal and the other is inclined. I^*_{on} is the extraterrestrial solar radiation for a given day "n". θ_z is the solar incident angle for the horizontal plane. θ is the solar incident angle for the inclined plane. The amount of extraterrestrial solar radiation on a plane can be calculated by multiplying the direct normal irradiance times the cosine of the incident angle.

Extraterrestrial Solar Radiation for the Inclined Plane is;

$$I^*_{o\beta} = I^*_{on} \cdot \cos\theta = I^*_o(1+0,033 \cdot \cos(360 \cdot n/365)) \cdot \cos\theta \quad (4.6.)$$

Extraterrestrial Solar Radiation for the Horizontal Plane is;

$$I^*_{oz} = I^*_{on} \cdot \cos\theta_z = I^*_o(1+0,033 \cdot \cos(360 \cdot n/365)) \cdot \cos\theta_z \quad (4.7.)$$

4.5. Solar Energy Collection for Horizontal System Built with North-South Oriented (Inclined) Planes

4.5.1. Introduction

It is known that overshadowing problem occurs while simulating a parabolic reflector with consecutive flat reflectors. While calculating the collected energy it is not chosen to subtract the overshadowed area from the total reflector plane and repeating this for all of the reflectors. Because overshadowed area and the inclination angle of each reflector change according to sun position.

Instead much simple method for calculating total energy is defined and applied. The distances between the reflectors are kept just enough to let them rotate around their axis. By this way all solar energy landed on the construction field of the system will be reflected to the receiver.

In (Figure 4.3.), (Figure 4.4.), (Figure 4.5.), (Figure 4.6.), (Figure 4.7.) systems with different reflector widths and reflector quantity are examined at the same time of the year. Total energy collected and the concentration ratios vary.

5 different system and their properties are listed in (Table 4.1).

(Table 4.1) - Properties of Examined "Reflector-Receiver" systems

	Width of Land (mm.)	Width of Reflectors (mm.)	Number of Reflectors (pcs.)
(Figure 4.3)	1000	1000	1
(Figure 4.4)	1000	500	2
(Figure 4.5)	1000	250	4
(Figure 4.6)	1000	125	8
(Figure 4.7)	1000	62,5	16

4.5.2. "1Reflector - 1 Receiver" System

A reflector has a width of 1000mm. is placed on a land which is also 1000mm wide. This reflector reflects the solar beams to the receiver right on top (Figure 4.3).

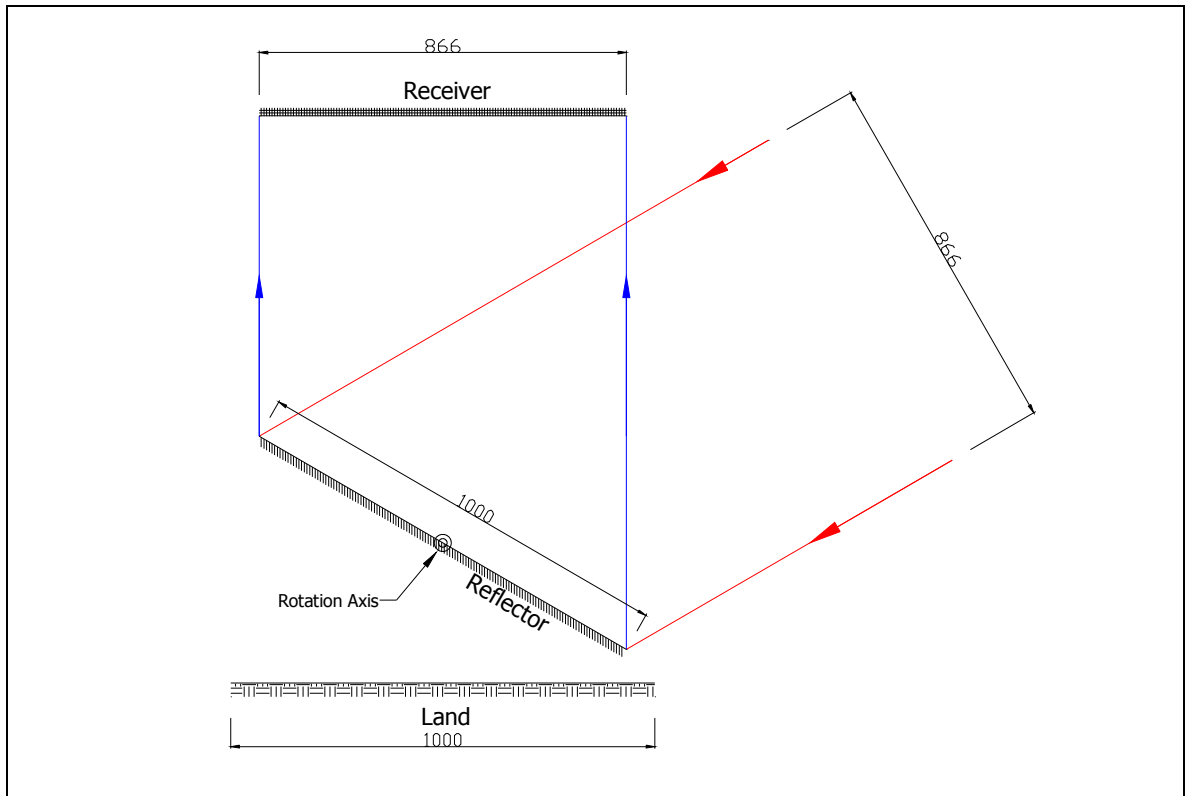

Figure 4.3. "1Reflector - 1 Receiver" System

(Figure 4.3.) is drawn for any moment in the year. **The next 4 systems are also examined for the same moment.**

The surface width, which is perpendicular to solar beams, is 866 mm. Also the width on receiver where the solar beams are focused is 866 mm. In this case the concentration ratio is;

$$\text{Concentration Ratio} = 866/866 = 1$$

4.5.3. "2 Reflector - 1 Receiver" System

Two reflectors both 500 mm. wide, are placed on the same land. Solar beams are reflected to the receiver right on top (Figure 4.4.)

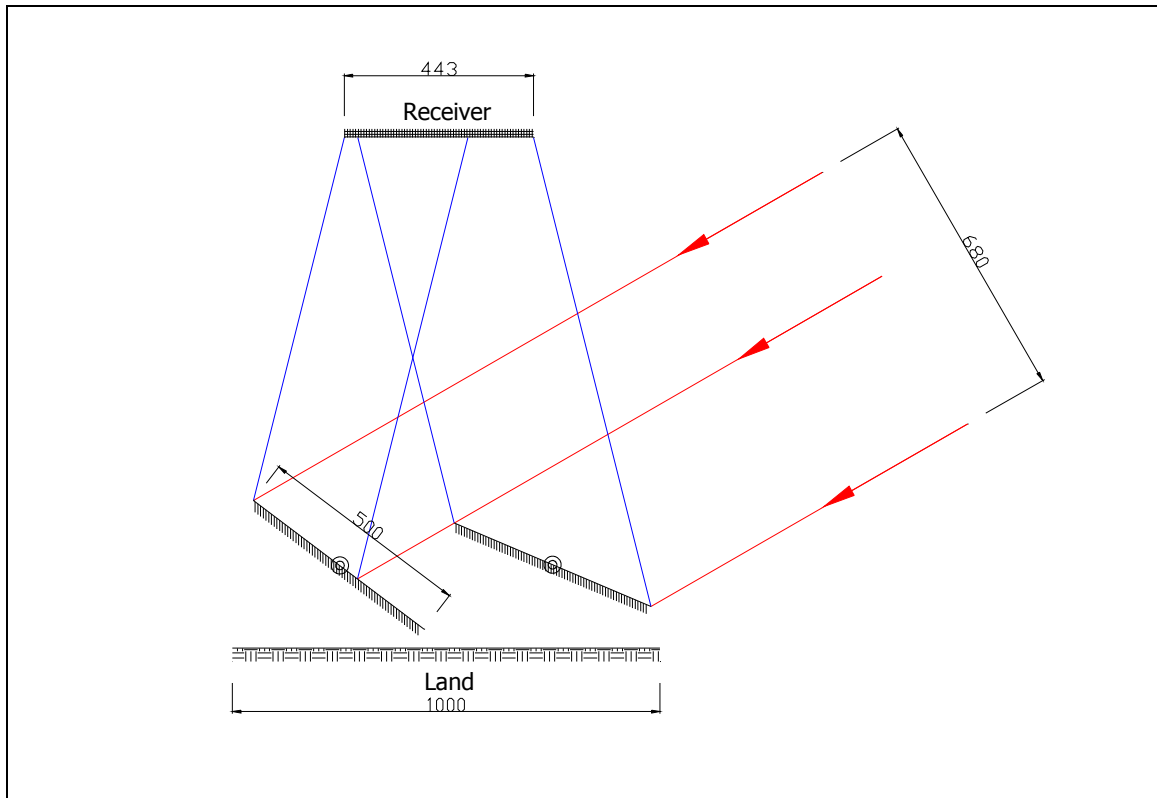

Figure 4.4. "2Reflector - 1 Receiver" System

In the previous system surface width, perpendicular to solar beams, was 866 mm. The present system with 2 reflectors has a surface width, which is perpendicular to solar beams, 680 mm. Also the width on receiver where the solar beams are focused is 443 mm. In this case the concentration ratio is;

$$\text{Concentration Ratio} = 680/443 = 1,535$$

4.5.4 "4 Reflector - 1 Receiver" System

4 reflectors all 250 mm. wide, are placed on the same land. Solar beams are reflected to the receiver right on top (Figure 4.5.).

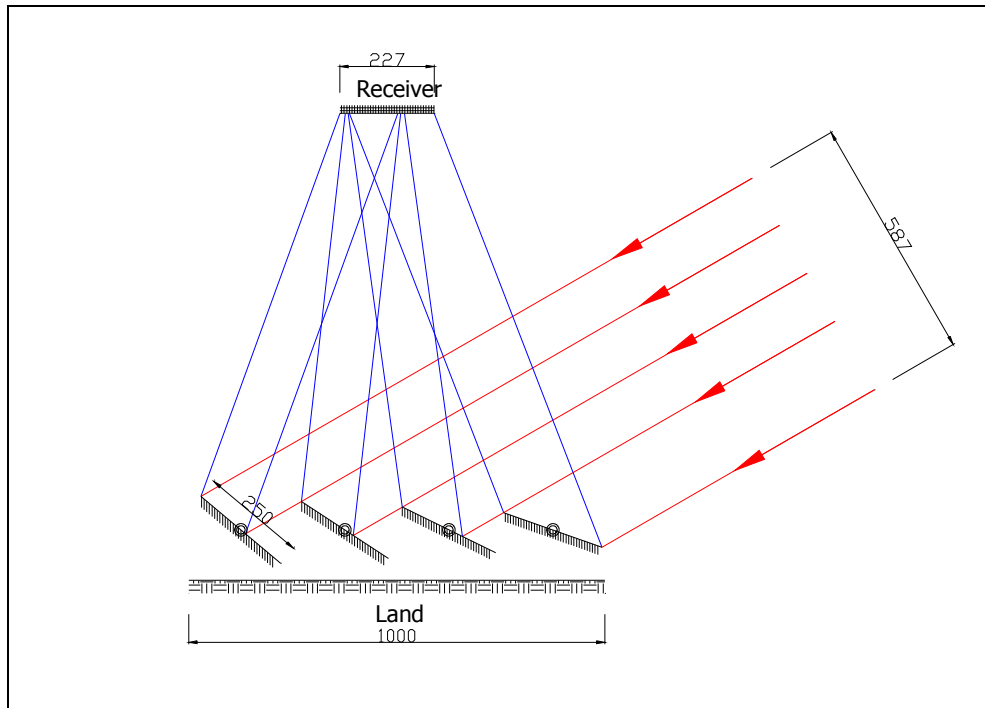

Figure 4.5. "4 Reflector - 1 Receiver" System

The present system with 4 reflectors has a surface width, which is perpendicular to solar beams, 587 mm. Also the width on receiver where the solar beams are focused is 227 mm. In this case the concentration ratio is;

$$\text{Concentration Ratio} = 587 / 227 = 2,585$$

4.5.5. "8 Reflector - 1 Receiver" System

8 reflectors all 125 mm. wide, are placed on the same land. Solar beams are reflected to the receiver right on top (Figure 4.6).

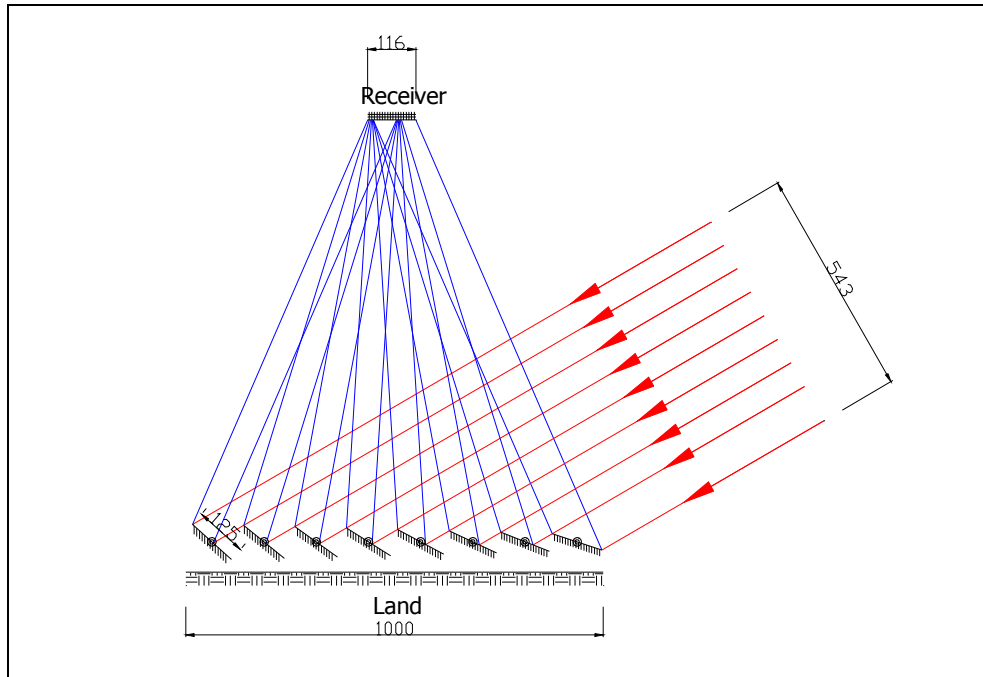

Figure 4.6. "8 Reflector - 1 Receiver" System

The present system with 8 reflectors has a surface width, which is perpendicular to solar beams, 543 mm. Also the width on receiver where the solar beams are focused is 116 mm. In this case the concentration ratio is;

$$\text{Concentration Ratio} = 543 / 116 = 4,681$$

4.5.6. "16 Reflector - 1 Receiver" System

16 reflectors all 62,5 mm. wide, are placed on the same land. Solar beams are reflected to the receiver right on top (Figure 4.7).

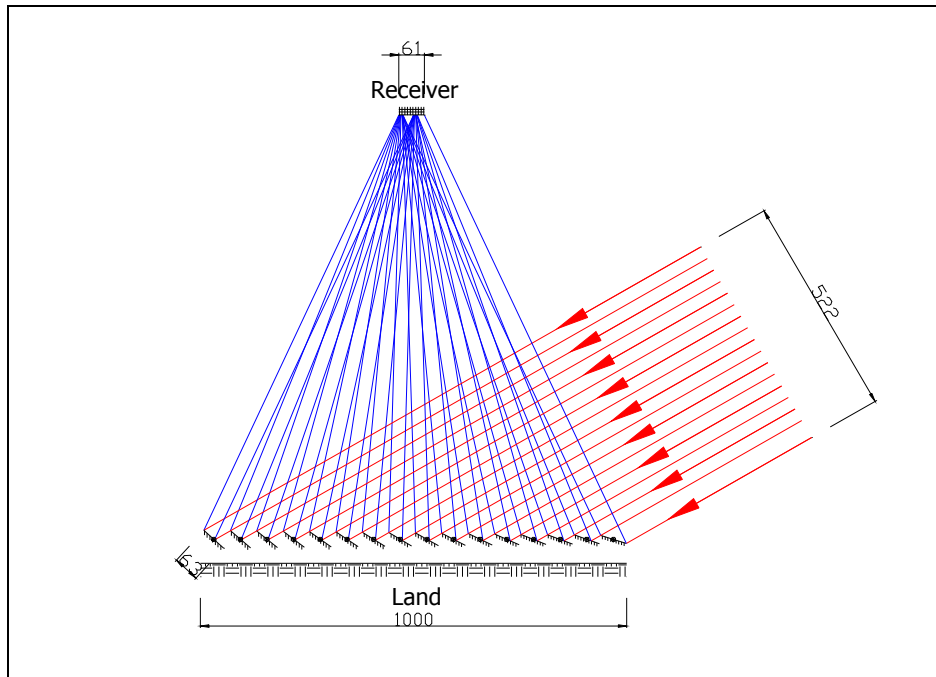

Figure 4.7. "16 Reflector - 1 Receiver" System

The present system with 16 reflectors has a surface width, which is perpendicular to solar beams, 522 mm. Also the width on receiver where the solar beams are focused is 61 mm. In this case the concentration ratio is;

$$\text{Concentration Ratio} = 522 / 61 = 8,557$$

4.5.7. Comparing the Systems

As shown in (Figure 4.9.) increasing the number of reflectors increases concentration ratio while decreasing the surface width, which is perpendicular to solar beams (Figure 4.8.). Differences in the surface width, which is perpendicular to solar beams decrease while approaching solar noon. This difference increases while moving away from the solar noon.

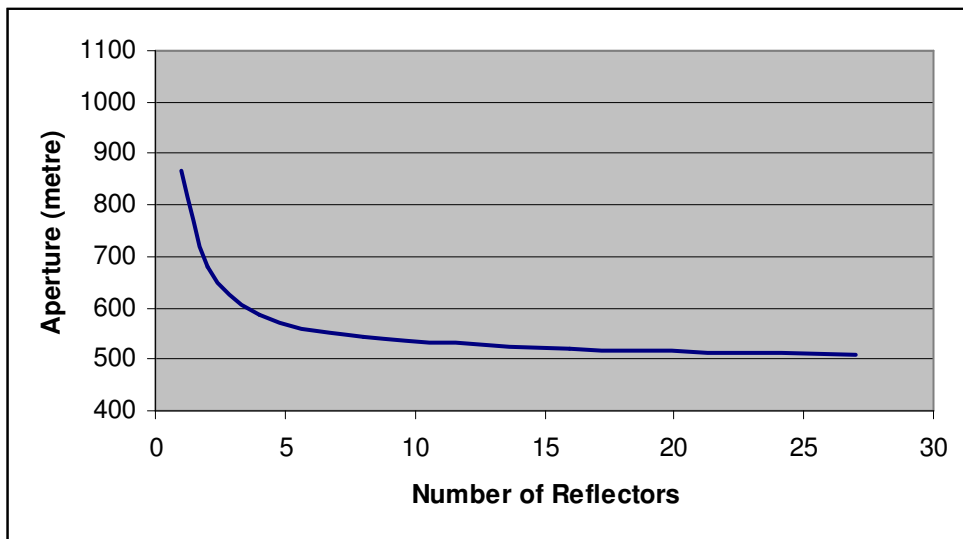

Figure 4.8. Aperture - Number of Reflectors

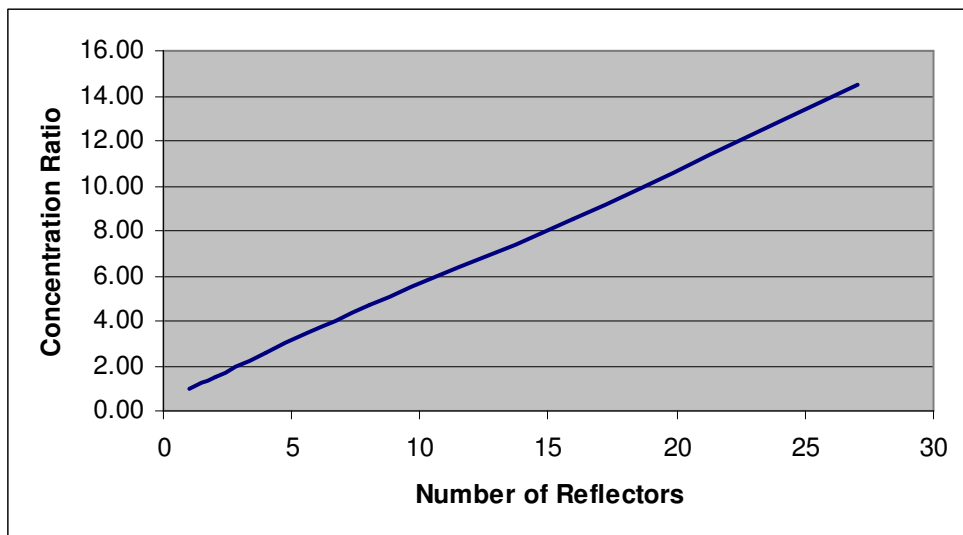

Figure 4.9. Concentration Ratio - Number of Reflectors

In Chapter 3 , a system with "27 Reflectors" was investigated and some figures, (Figure 3.10), (Figure 3.11), (Figure 3.12), showing this system for different times in a day were given. Some properties for the system with "27 Reflectors" can be seen in following figures. (Figure 4.10), (Figure 4.11), (Figure 4.12)

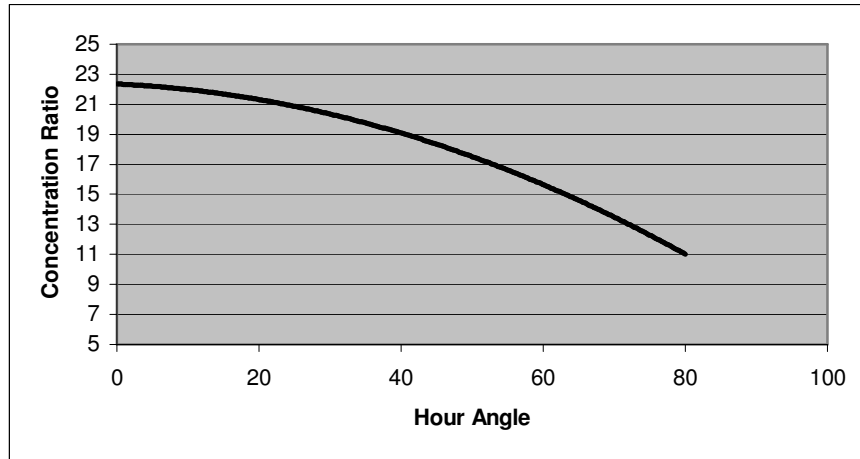

Figure 4.10 Concentration Ratio - Hour Angle

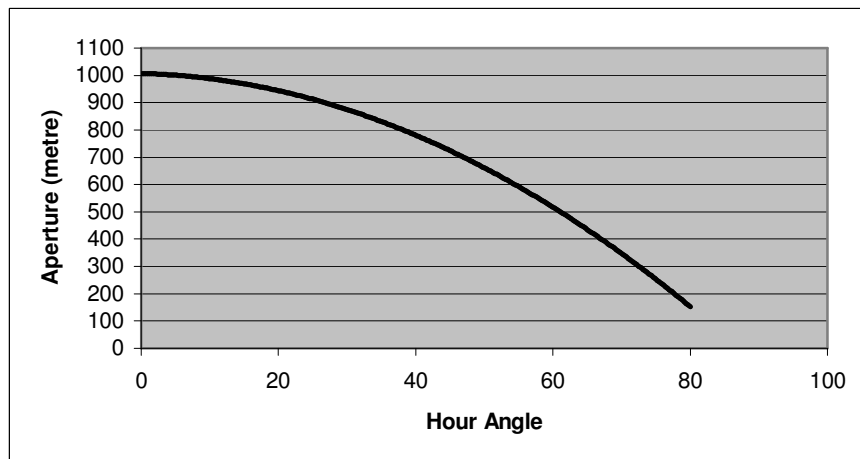

Figure 4.11 Aperture - Hour Angle

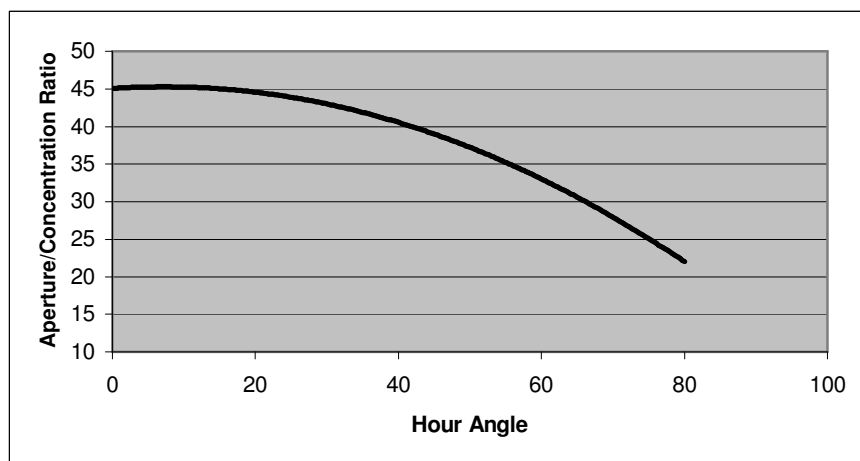

Figure 4.12 Aperture/Concentration Ratio - Hour Angle

4.5.8. Simple Way to Calculate the Total Area

To find the aperture for a given moment, two edges of the system can be connected with a virtual line (Figure 4.13). Procured line can be used to determine the extraterrestrial solar radiation amount at a certain moment.

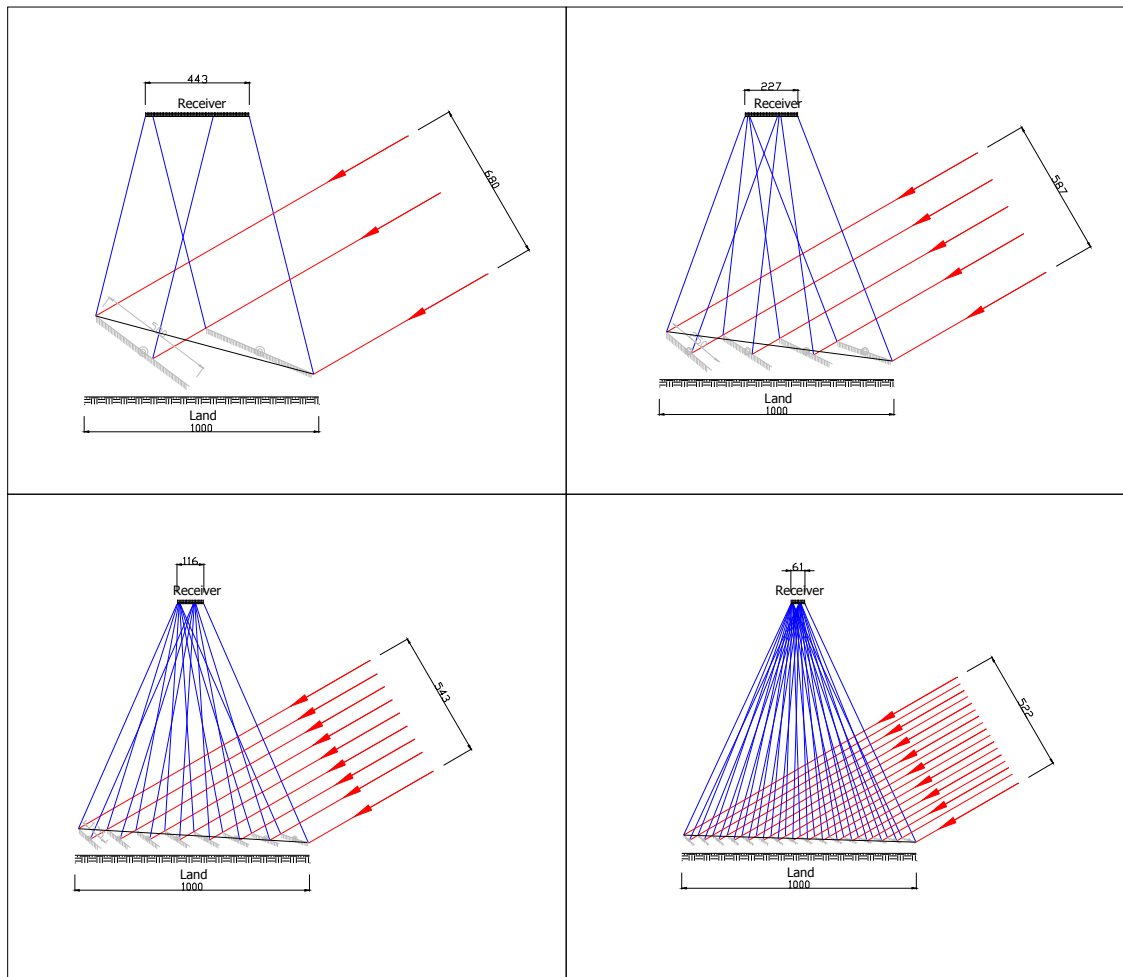

Figure 4.13 Virtual Line

When continued increasing number of reflectors the inclination angle between the horizontal plane and the virtual line (connects two edges of the system) decreases. For the system in Chapter 3 with "27 Reflectors", virtual line has an inclination angle variation approximately $\pm 1^\circ$ through out the entire year. So instead of calculating amount of energy reflected from each separate reflector and adding them to calculate the total energy, **the energy amount collected on the horizontal field, where the system is build can be calculated.**

4.6. "27 Reflector - 1 Receiver System"

4.6.1. Horizontal "27 Reflector - 1 Receiver System"

In (Figure 4.14.) 27 Reflector - 1 Receiver System at any moment is shown. In next (Figure 4.15.) edge points of the reflectors are connected with a virtual plane. This virtual plane shown with a red frame around can be assumed as a horizontal virtual plane shown with blue frame around (Figure 4.16). This final situation simplifies our calculations.

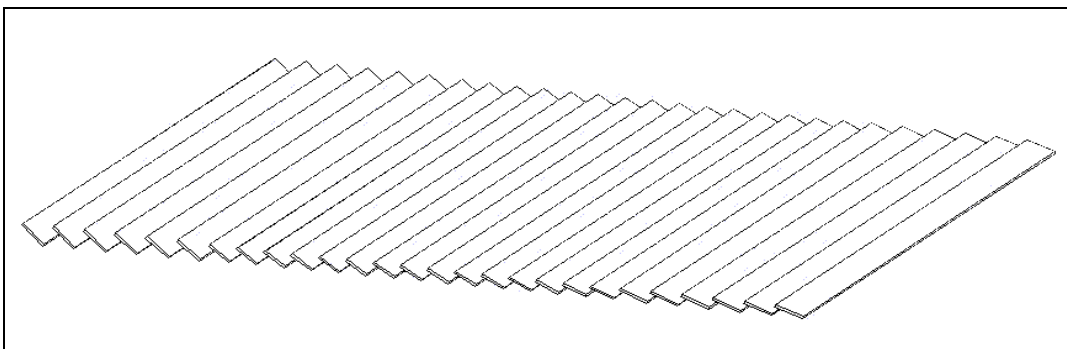

Figure 4.14 Horizontal "27 Reflector - 1 Receiver System"

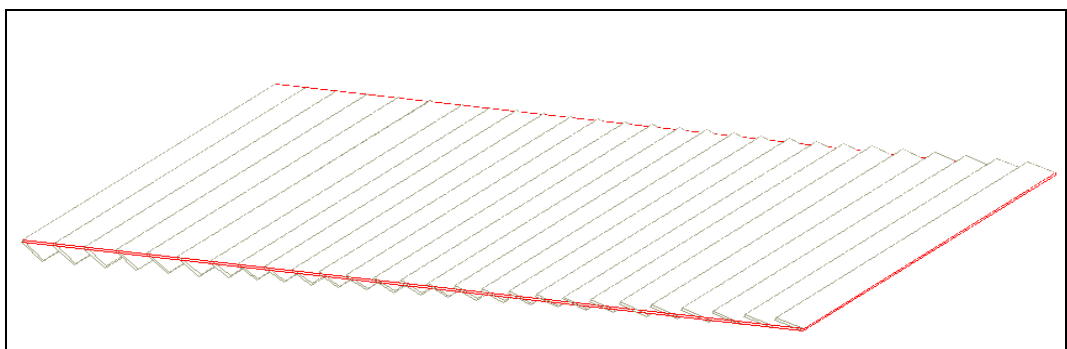

Figure 4.15 Inclined Virtual Plane

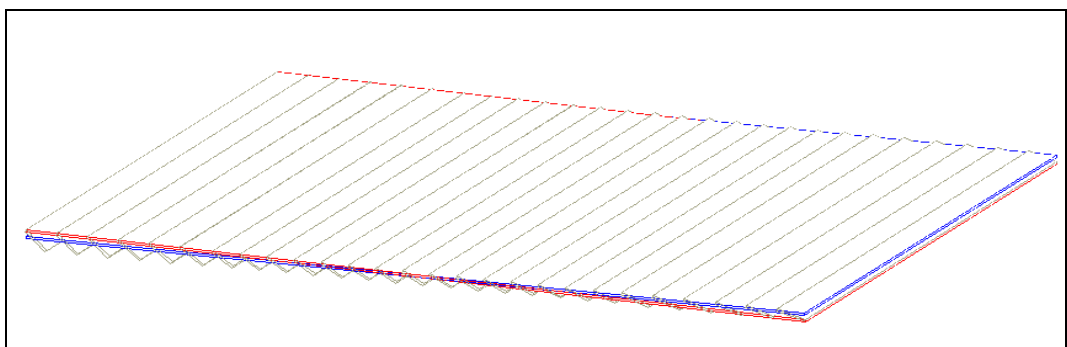

Figure 4.16 Horizontal Virtual Plane

4.6.2. South Facing "27 Reflector - 1 Receiver System"

As mentioned in Chapter 2 systems can be constructed facing to south with a constant angle (Figure 4.17). In this case a virtual plane placed on the reflectors can be used to calculate the total energy collected in a day or the entire year.

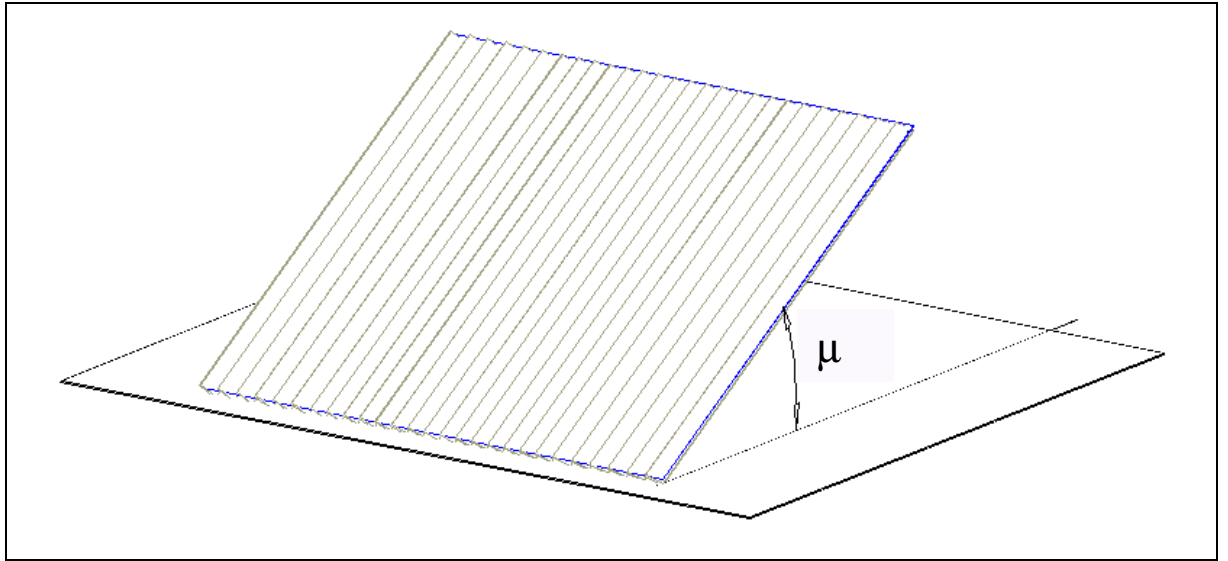

Figure 4.17 South Facing "27 Reflector - 1 Receiver System"

In this case extraterrestrial solar radiation can be calculated at a certain moment for a system facing south with μ angle. Calculation for an entire day can be made by integrating (Equation 4.6.). Equation 4.8. is used to calculate the extraterrestrial solar radiation collected between ω_1 and ω_2 hours angles.

$$\begin{aligned}
 I_{\text{on}\beta}^* &= (24 \cdot 3600 / 2\pi) \cdot I_o^* \cdot (1 + 0,033 \cdot \cos(360 \cdot n / 365)) \\
 &[\sin\delta \cdot \sin\phi \cdot \cos\mu \cdot (2\pi/360) \cdot (\omega_2 - \omega_1) - \sin\delta \cdot \cos\phi \cdot \sin\mu \cdot \cos\gamma \cdot (2\pi/360) \cdot (\omega_2 - \omega_1) \\
 &+ \cos\delta \cdot \cos\phi \cdot \cos\mu \cdot (\sin\omega_2 - \sin\omega_1) + \cos\delta \cdot \sin\phi \cdot \sin\mu \cdot \cos\gamma \cdot (\sin\omega_2 - \sin\omega_1) \\
 &+ \cos\delta \cdot \sin\mu \cdot \sin\gamma \cdot (\cos\omega_2 - \cos\omega_1)] \quad (4.8.)
 \end{aligned}$$

(Equation 4.8.) can be rewritten for the south looking plane which has the azimuth angle ($\gamma=0$) as follows;

$$I_{\text{on}\beta}^* = (24 \cdot 3600 / 2\pi) \cdot I_o^* \cdot (1 + 0,033 \cdot \cos(360 \cdot n / 365))$$

$$[\sin\delta \cdot \sin\phi \cdot \cos\mu \cdot (2\pi/360) \cdot (\omega_2 - \omega_1) - \sin\delta \cdot \cos\phi \cdot \sin\mu \cdot (2\pi/360) \cdot (\omega_2 - \omega_1)$$

$$+ \cos\delta \cdot \cos\phi \cdot \cos\mu \cdot (\sin\omega_2 - \sin\omega_1) + \cos\delta \cdot \sin\phi \cdot \sin\mu \cdot (\sin\omega_2 - \sin\omega_1)] \quad (4.9.)$$

5 systems with "27 Reflectors" and different south facing angles are investigated. Systems are built in İzmir and the only difference to each other is their "south facing inclination angles". Extraterrestrial Solar Radiation according to the days in a year is given in (Figure 4.18).

The area under the curves gives the total "annual extraterrestrial solar radiation" for the given "south facing inclination angles". A graphic for the "annual radiation" according to the "south facing angles μ " is given in (Figure 4.19).

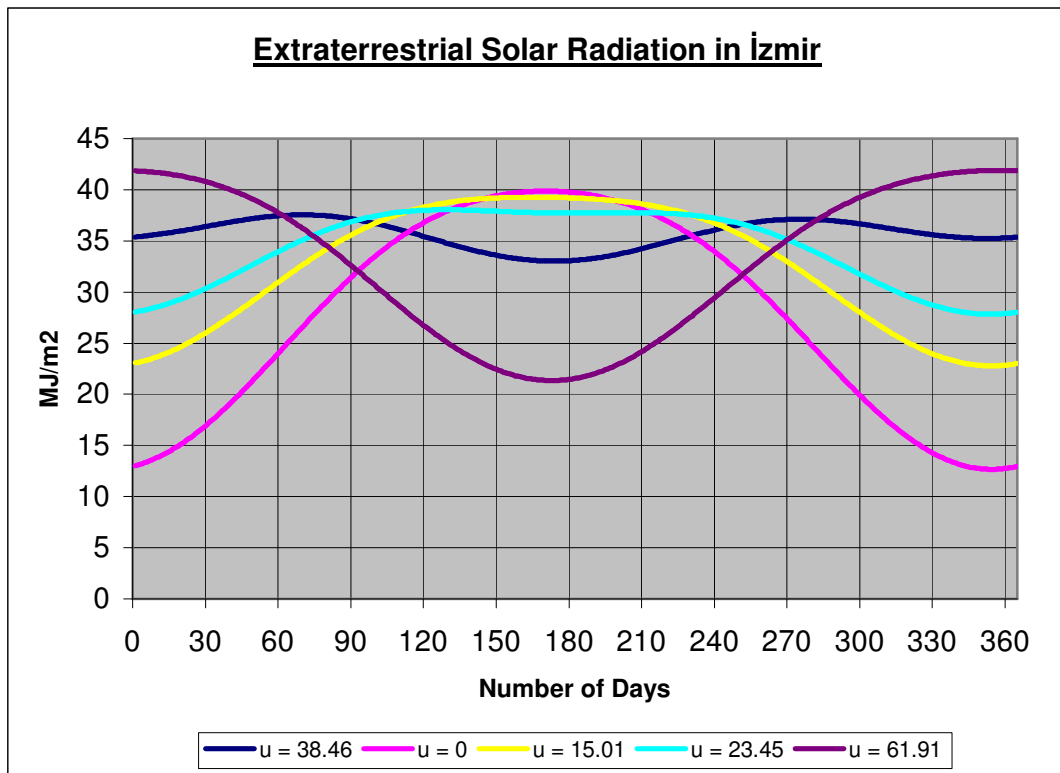

Figure 4.18 Extraterrestrial Solar Radiation in İzmir

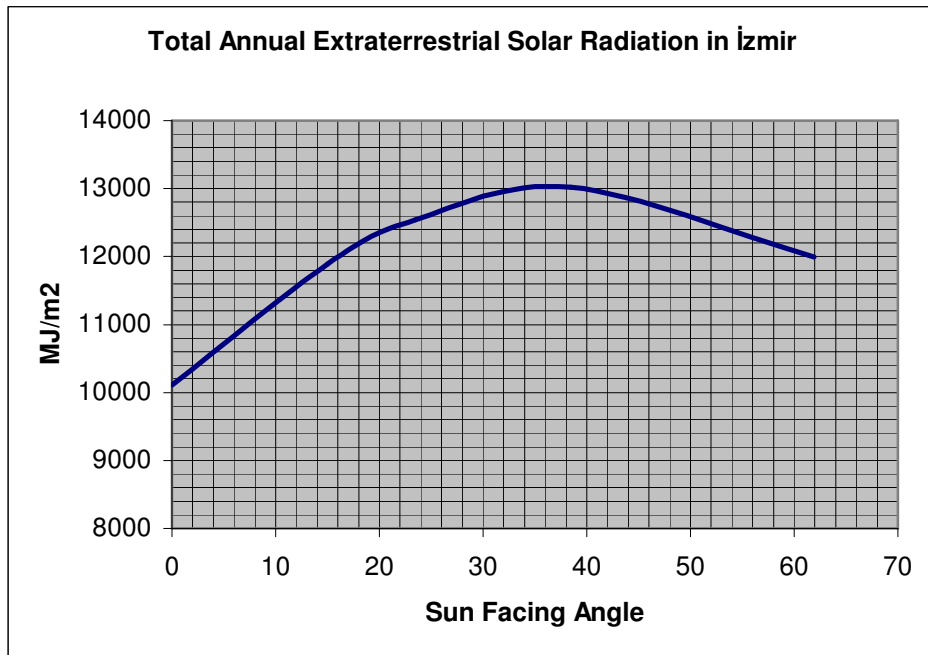

Figure 4.19 Total Annual Extraterrestrial Solar Radiation in İzmir

CHAPTER 5

POWER PLANT

5.1. Introduction

In previous chapters some investigations including the tracking possibilities energy calculations and the simplicity of the manufacturing process are made. After all system comparisons a configuration is constituted.

The power plant will be constructed from multiple modules facing south. Water will be carried over to each module while hot steam is produced. The inclination angle(μ) of the modules will be constant and equal to the latitude. Each module will reflect the solar beams to the receiver on top of it self.

The advantage of this design is the simplicity of the tracking system. Tracking system will be controlled with a constant speed motor.

In this chapter system designed for İzmir City will be introduced.

5.2. Power Plant

(Figure 5.1.) shows the simulation of the projected power plant.

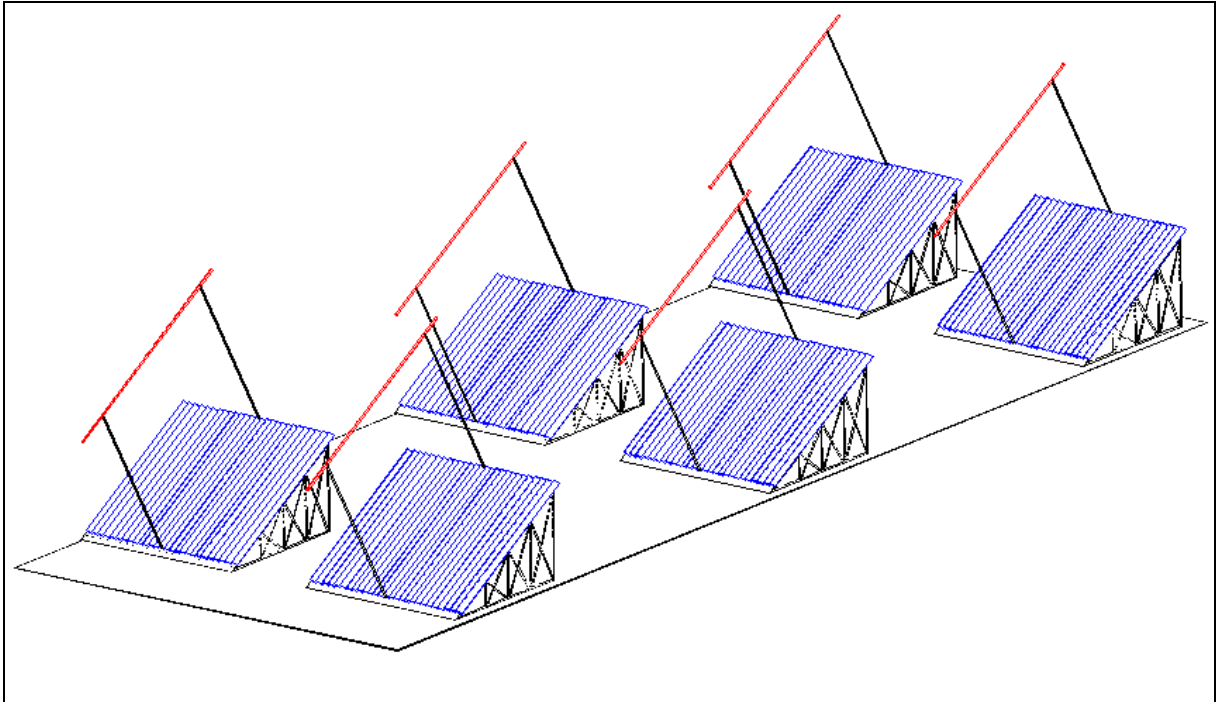

Figure 5.1. Simulation of the Power Plant

Each reflector group colored with blue reflects solar beams to their receivers marked as red

5.3. Module

Single module can be examined in (Figure 5.2.).

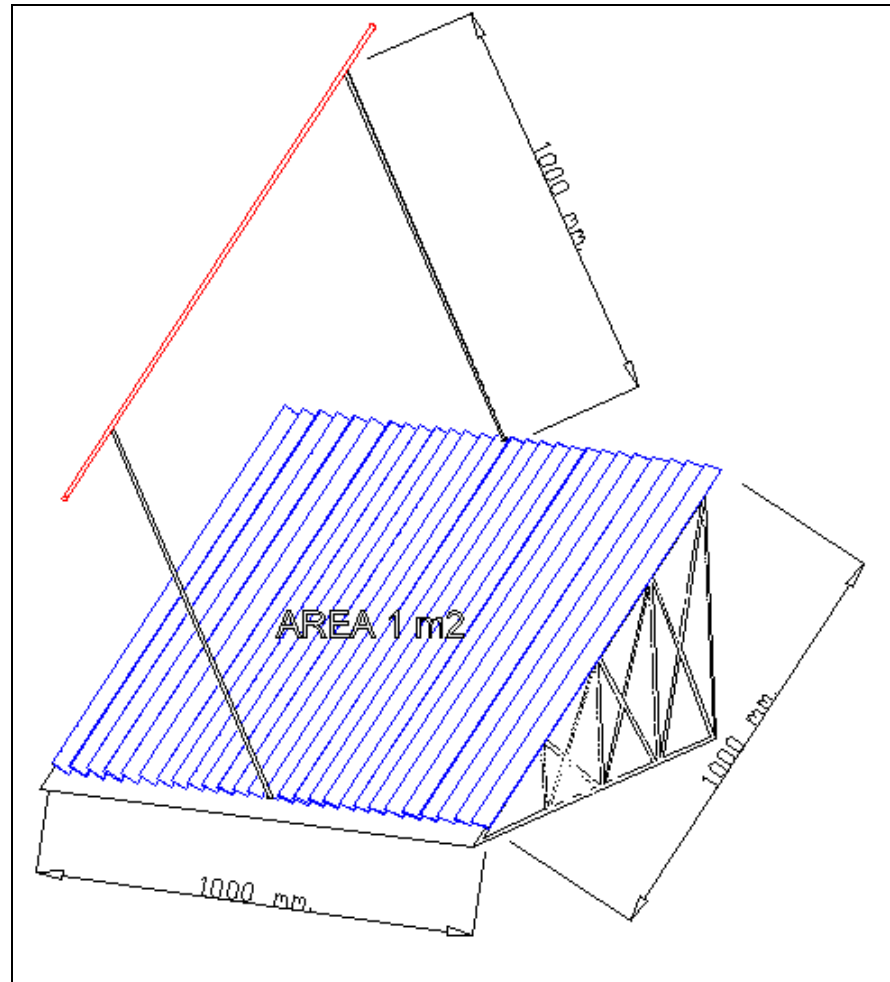

Figure 5.2. Overall Lengths of a Module

Rotation axes of the reflectors are not pointed in (Figure 5.2.) to the fact that they are investigated in previous chapters.

Selections will be explained and reasons will be discussed. These are;

- Reflector quantity, width, calibration angle
- Receiver width, length, position
- Module's "south facing angle(μ)" - Reflector rotation angles

5.3.1. Reflector Quantity, Width, Calibration Angle

Parabola $y=x^2/4000$ is simulated with 27 reflectors. Reflector at the center is assumed to be the reference reflector and numbered with (0). From the reference reflector to west reflectors are numbered 1 to 13 and to east reflectors are numbered -1 to -13. (Figure 5.3.)

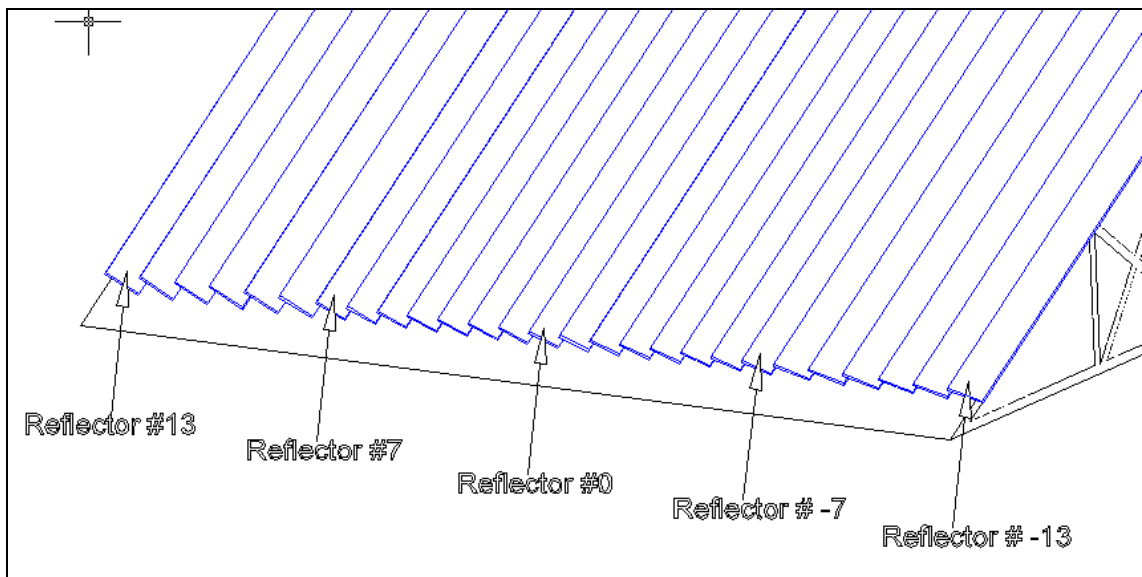

Figure 5.3. - Reflector Numbers

Reflector numbers, widths and calibration angles are given in (Table 5.1.).

Table 5.1. Calibration Angle of Reflectors

Reflector No	Calibration Angle (β) (DGR)	Reflector Width (mm.)
13	13°	38
12	12°	38
11	11°	38
10	10°	38
9	9°	38
8	8°	38
7	7°	32
6	6°	32
5	5°	32
4	4°	32
3	3°	32
2	2°	32
1	1°	32
0	0°	32
-1	-1°	32
-2	-2°	32
-3	-3°	32
-4	-4°	32
-5	-5°	32
-6	-6°	32
-7	-7°	32
-8	-8°	38
-9	-9°	38
-10	-10°	38
-11	-11°	38
-12	-12°	38
-13	-13°	38

Calibration angles are chosen so that they are integers which can be measured easily. So the possible problems can be solved easily.

5.3.2. Receiver Width, Length, Position

To benefit from the sun at maximum during the day and prevent heat losses from unnecessary length of the receiver this analysis is made.

In Chapter 4 at (Figure 4.12.) "Aperture/Concentration Ratio - Hour Angle" graph is given. It can be seen that maximum receiver width is required at solar noon ($\omega=0$) because the width of the image of the focused solar beams is maximum at solar noon. To determine the reflector width at solar noon (Figure 3.10.) is utilized. According to this analysis maximum width of 45 mm. occurs.

For determining total receiver length (Figure 2.36.), (Figure 2.37.) , (Figure 2.38.) , (Figure 2.39.) , (Figure 2.40.) can be used. For these 5 graphical situation it can be said that;

➤ Minimum v/h ratio occurs when the module is inclined with an angle equal to the latitude. In our case İzmir this angle is 38.46° and v/h ratio changes between (-0.4 /+0.4). So, for 1000 mm. reflector length, 1800 mm. receiver length is proper if placed 1000 mm. over the reflectors. Also this case has 2 advantages;

1. Landing point of the image of the focused solar beams is constant when observed in respect of the day of the year.
2. Reflected solar beams have a linear variation in the year. In this case receiver can be movable in the North/South direction. Easy controlling is possible by the means of linear relation.

There are 2 possibilities;

1. Fixed receiver which is 1800 mm. long. In this case the receiver will be 400 mm. longer from North and South directions (Figure 5.4)
2. Movable receiver, which is 1000 mm. long. In this case the receiver should be translated 2.2 mm. in the North/South axis every day (Figure5.5.). Translation direction can be determined from (Figure 2.39.). In (Figure 5.6.) and (Figure 5.7.) 2 sample positions are shown for different days.

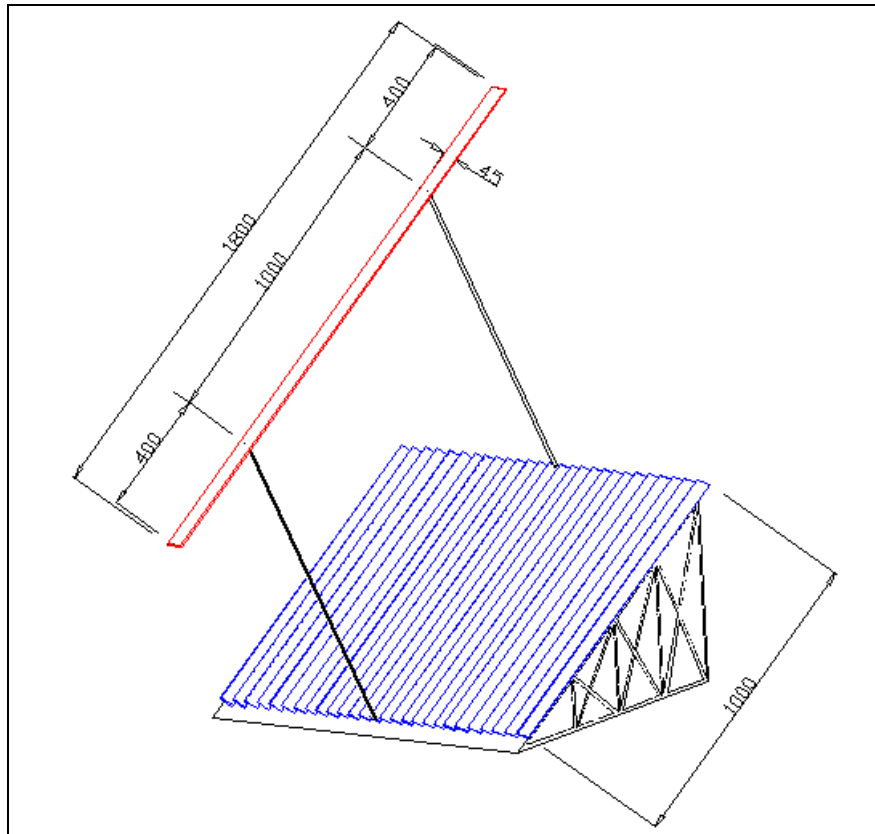

Figure 5.4. Fixed Receiver

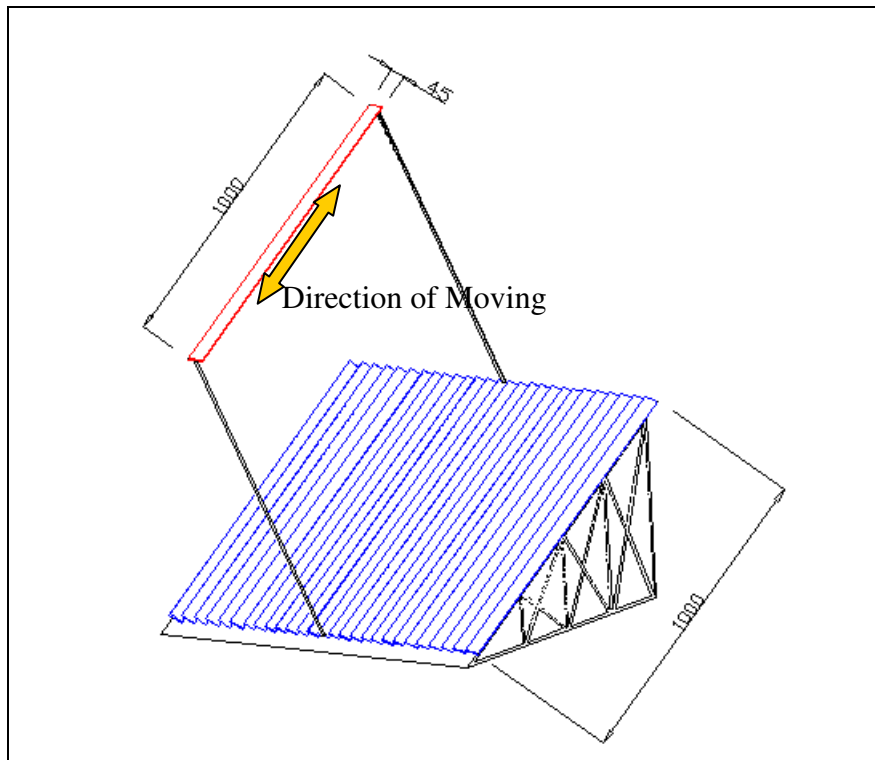

Figure 5.5. Movable Receiver

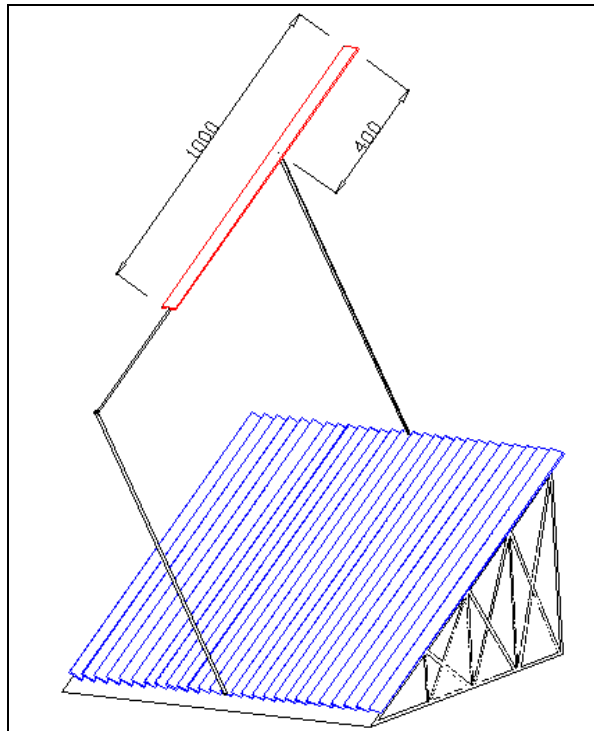

Figure 5.6. Position of "Movable Receiver" on January #1

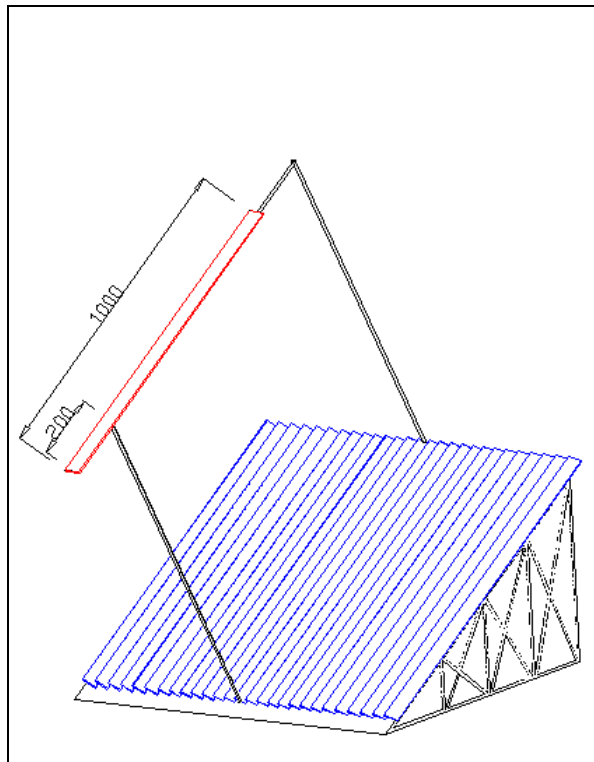

Figure 5.7. Position of "Movable Receiver" on August #20

5.3.3. Module's South Facing Angle (μ) - Reflector Rotation Angle

Reflector rotation angles are compared and given in (Figure 2.25 - 2.34.). Most interesting result is obtained when the module is inclined to south with an inclination angle equal to the latitude. (Figure 2.31.) , (Figure 2.32.) ;

- In this condition reflector's rotations should be linearly related with hour angle. This means that with a motor able to supply constant rotation speed, reflectors can be controlled without the need of computerized system.
- More interesting is that for an entire year same hour angle is congruent with the reflector angle.
- Motion mechanism has a linear relation with time. Motor with constant rotation speed or the steam obtained from the power plant can be used to rotate the reflectors. A simple mechanism like a winded clock can rotate reflectors so that solar beams continuously hit the receiver **with very high resolution.**

In the entire year there is a linear relation between rotation and hour angle. But the hour angle representing solar time should be transformed to local time by using "equation of time" and a correction should be made every day to the motion mechanism.

5.4. Solar Energy Collection

As mentioned in Chapter 4, a plane and a module placed on the same area collect 99% equal amount of extraterrestrial radiation. Maximum temperature obtained from a power plant is dependent on;

1. Single modules area and the total energy it can collect
2. Water amount in the system
3. Amount of modules that the water will pass
4. Material, geometry and isolation of the receiver.
5. Isolation of the connection between the modules.
6. Reflectors geometry, width and quantity.
7. Reflection properties of the reflectors
8. Concentration value

The analysis in Chapter 4 shows that the maximum energy collection and most uniform distribution through out the year are obtained when the module is inclined equal to the latitude facing the south. (Figure 4.18) (Figure 4.19).

Each module collects 13000 MJ of energy, on an area 1000mm. long and 45 mm. wide in a year. This value is calculated using extraterrestrial radiation and will decrease according to atmospherically and meteorologically conditions. Absorption capacity of the receiver material, isolation of the heated water affects the maximum temperature that the water will reach. In this study geometrical properties are examined to figure out the best configuration while heat and temperature analysis are left out.

CHAPTER 6

CONCLUSION

Subjected "concentrating solar power plant" produces electric power by converting the sun's energy into high-temperature heat using "Fresnel Design" mirror configuration. The heat is then channeled through a conventional generator. Plant consists of two parts: one that collects solar energy and converts it to heat, and another that converts heat energy to electricity.

Aim of this study is to project an inexpensive solar collector to build small or large scale "solar power plants". Fresnel design is chosen because of its low cost of planar reflectors, possible simple tracking mechanism and practicability for large/small scale power plants.

This study is based on the geometrical properties of the mentioned solar collector. Material selection of the reflector, receiver or tracking mechanism; design of the receiver; heat transfer calculations are the subjects for the future work.

In the conclusion of the studies south facing module design in 1 m^2 is developed. Reflectors made of flat mirrors are preferred because of their inexpensive price and easy handability. According to the size and capacity of the solar thermal plant the number of modules can be adjusted. The total extraterrestrial radiation amount is calculated for a single module. Yearly, 13000 MJ extraterrestrial solar radiation can be collected and focused on a area 1000mm.long/45mm.wide. The structural dimensions of the receiver, which the solar beams are focused on, are determined and the geometrical position change in a year is calculated. Also amount of reflectors, structural features of each reflector, positioning and positioning change of each reflector is determined.

Changes in reflector amount, concentration ratio and south facing angle are studied during the calculation of the total gross energy collected. Maximum total energy collected throughout the year is when module facing south with inclination angle equal to the latitude. Also it is understood that increasing number of the reflectors increases concentration ratio while decreasing the total energy collected. This analysis is important for the highest reachable temperature of the fluid in the receiver.

Module is projected with a "single axis sun tracking system" inside. Rotation axis is placed in North/South direction. Each reflector can rotate around its axis. One of the most important things achieved during the study is the method for calculating rotation angle of the reflectors for the entire day and year. "**direct solar beam**" and "**reflected solar beam**" vectors are defined respect to the reflector and the receiver at any place for any time of the year. Also equations for calculating the exact targeting position (on the receiver) of the reflected solar beams are developed.

Reflector angles should change continuously so that the reflected sunbeams hit the receiver. Reflector angles are calculated both for horizontal placement and inclined placement that which the module facing to south. Changes in the reflector angles are linearly related with time while the reflectors are placed at an inclination angle equal to the latitude. In this case required reflector angle for the reflectors are equal for entire year at the same hour of the day. This linear relation removes the necessity of complex controlling elements. Steam obtained from the power plant can be used to rotate the reflectors. A simple mechanism like a winded clock can rotate reflectors so that sunbeams continuously hit the receiver. And this mechanism can get its energy from the steam. This is an important development because in this case firsthand energy will be used to track the sun. **Total efficiency of the power plant will be better.**

Besides the simplicity of the reflector control mechanism, receiver positioning has a linear relation between time. A receiver sliding 2.2mm/day can collect all of the reflected beams.

Result of this study is a special "Solar Concentrating Collector Module" which can be used as the basic part to construct a large or small scale power plant.

CHAPTER 7

MISCELLANEOUS WORK

&

RECOMMENDATIONS FOR FUTURE WORK

7.1. Domestic Usage

The simplicity of the design makes it possible that the designed module can take place of the common house sun panels. Defined 1m^2 modules with 27 reflectors and a receiver can be installed on the roofs of the buildings very easily. Simplicity of the sun tracking system reduces the module cost. Directly a steam forced clock or a 220 V AC Motor can rotate the reflectors. Thus heating of usage water would be possible in winter time.

7.2. New Equation for "Solar Incident Angle for Inclined Plane"

While developing the equations in Chapter 2, to control the method some different works has been done. By using the same method of "rotation angles", a new "solar incident angle for inclined plane" equation is developed. And this new equation is compared with the one in the literature.

Simplified drawing in the literature for the relation between the earth and the solar beam is shown in (Figure 7.1.). And in (Figure 7.2.) the actual position is shown. The plane is at the "P" point on the earth.

The "Solar Incident Angles (θ)" in both drawings are the same as scalar values. But the "P" points are not at the same position respect to the observer (reader).

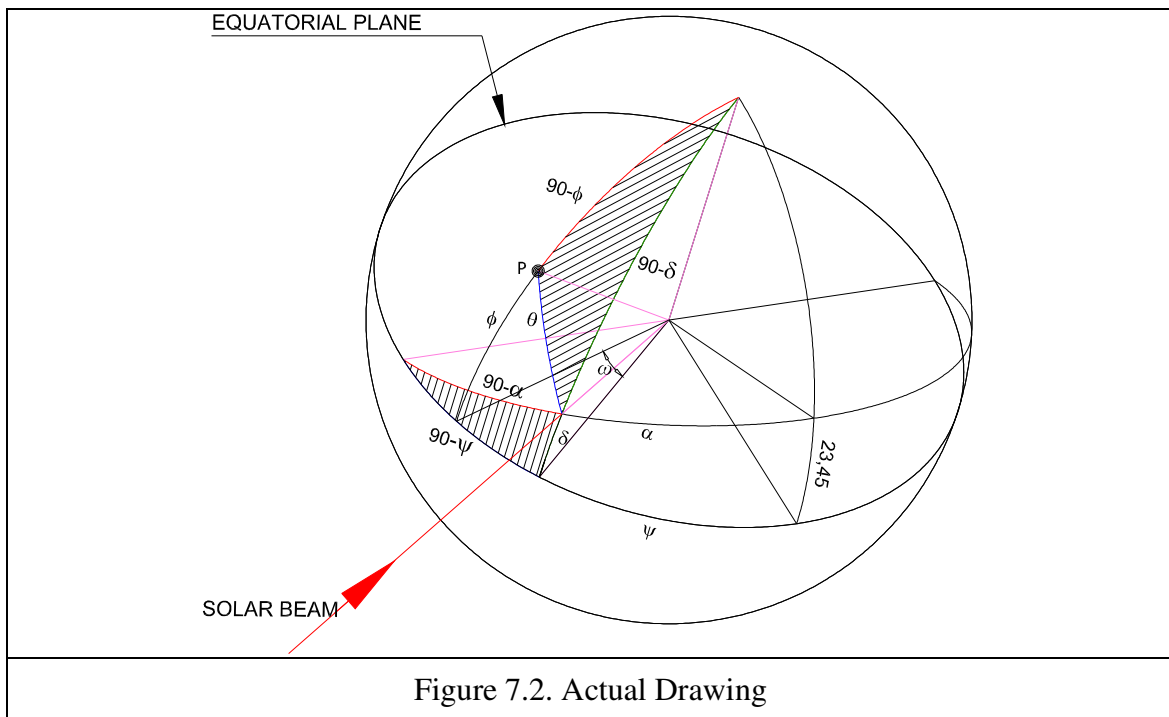
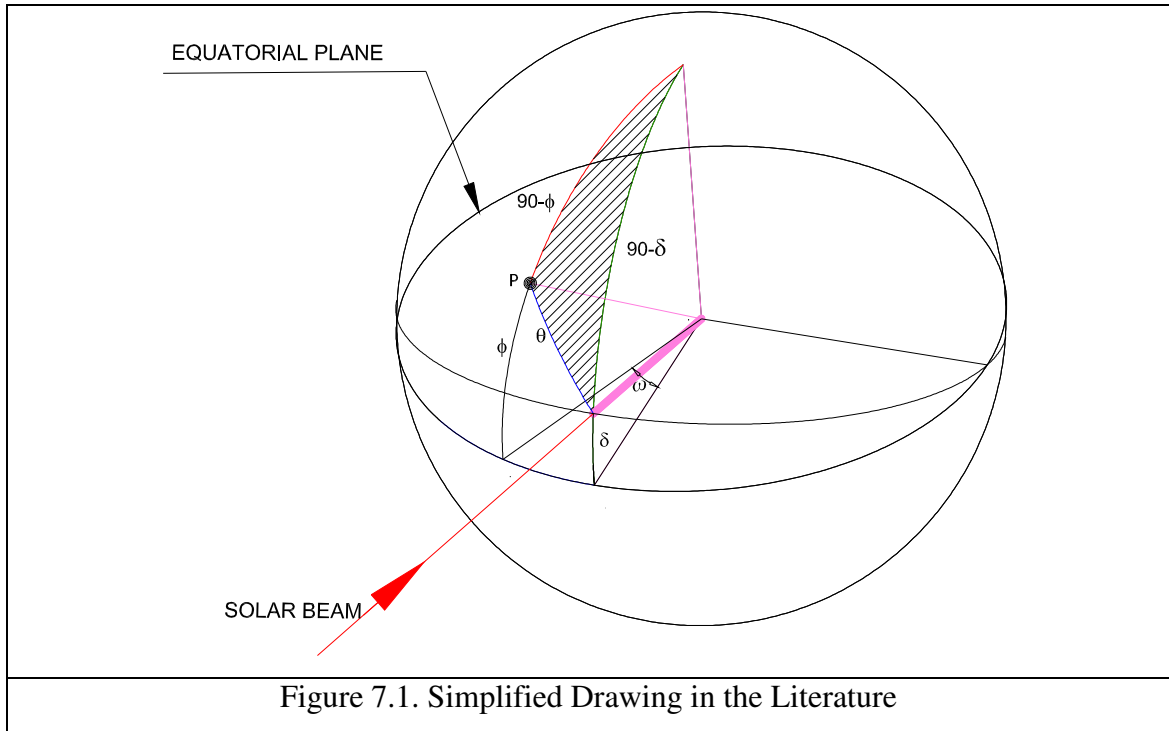

It can be said that; when the "P" point in (Figure 7.1.) is rotated about the axis which is in the direction of the solar beam, the "P" point in (Figure 7.2.) will be obtained. This is the reason why the simplified drawing and its equations work properly. Because the rotation axis is the solar beam's direction, none of the scalar results, which are calculated with the equations in the literature, are wrong.

The new equation and the one in the literature are given below.

For both of them there are 5 variables;

n : number of the days

ω : hour angle

ϕ : Latitude

μ : Inclination angle of plane (south facing)

γ : Surface azimuth

7.2.1. New Equation

$$\alpha = \frac{-360}{365} \cdot (n + 10)$$

$$\psi = \arctan\left(\frac{-\tan \alpha}{\cos 23,45}\right)$$

$$\begin{aligned} \cos\theta = & (\cos\phi \cdot \cos\mu - \sin\phi \cdot \cos\gamma \cdot \sin\mu) \cdot (\cos(\psi+\omega) \cdot \cos 23,45 \cdot \cos\alpha - \sin(\psi+\omega) \cdot \sin\alpha) \\ & - \sin 23,45 \cdot \cos\alpha \cdot (\sin\phi \cdot \cos\mu - \cos\phi \cdot \cos\gamma \cdot \sin\mu) \\ & - \sin\gamma \cdot \sin\mu \cdot (\sin(\psi+\omega) \cdot \cos 23,45 \cdot \cos\alpha + \cos(\psi+\omega) \cdot \sin\alpha) \end{aligned}$$

7.2.2. Equation in the Literature

$$\delta = 23,45 \cdot \sin\left(\frac{360 \cdot (284 + n)}{365}\right) \text{ (Declination Angle)}$$

$$\begin{aligned} \cos\theta = & (\sin\delta \cdot \sin\phi \cdot \cos\mu) - (\sin\delta \cdot \cos\phi \cdot \sin\mu \cdot \cos\gamma) + (\cos\delta \cdot \cos\phi \cdot \cos\mu \cdot \cos\omega) \\ & + (\cos\delta \cdot \sin\phi \cdot \sin\mu \cdot \cos\gamma \cdot \cos\omega) + (\cos\delta \cdot \sin\mu \cdot \sin\gamma \cdot \sin\omega) \end{aligned}$$

7.2.3. Comparison of two Equations

Some randomly selected situations are given in (Table 7.1.).

VARIABLES/SITUATIONS	1.	2.	3.	4.	5.	6.	7.
n	1	50	100	150	200	250	300
ω	-60	-30	-15	0	15	30	60
ϕ	0	15	30	45	60	75	90
μ	5	10	15	20	25	30	35
γ	-40	-20	-10	0	10	20	40
θ (in Literature)	61,509	44,436	38,483	43,249	62,969	91,303	95,650
θ (new developed)	61,508	44,303	38,758	43,379	63,050	91,347	95,371
Angular Difference	0,01	0,13	0,28	0,13	0,08	0,04	0,28

Table7.1. Solar Incident Angles

7.2.4. Future Work for the Equations

In (Table 7.1.) there are angular differences maximum in three tenth of a degree. Actually both equations do not express the actual phenomenon. For a better approach the sun-earth relation must be examined in elliptical coordinates. But in case of elliptical coordinates the tracking system will not work linearly with time. This will cause to a complex and expensive tracking control mechanism. On the other hand this will help to define the angular errors of the projected module's tracking system. So that maybe the receiver's width can be adjusted to collect all the reflected beams.

REFERENCES

- Atagündüz,G., “*Güneş Enerjisi Temelleri ve Uygulamaları*”, Ege Üniversitesi Basımevi, 1989.
- Armakan, E., “*Analysis of Two-Axis Sun Tracking System*” Master Thesis, Izmir Institute of Technology, April 2003
- D’azzo, J. J. and Houppis, C. H., “*Linear Control System Analysis and Design*”, McGraw-Hill Book Company, 1995.
- Duffie, J.A. and Beckman, W.A. “*Solar Engineering of Thermal Processes*”, a Wiley-Interscience Publication, 1991.
- Gandhidasan, P. and Satcunanathan, S. “Energy collection augmentation in tracking flat plate collectors”, *Proceedings of Sun World Forum*, Brighton, 1981, pp. 186-191.
- Häberle, Andreas and Zahler, Christian, “*The Solarmundo Project Advanced Technology for Solar Thermal Power Generation*” ISES 2001 Solar World Congress
- Hsieh, J. S., New Jersey Institute of Technology “*Solar Energy Engineering*”, Prentice-Hall, 1986.
- Jones, Scott A. et al., “*TRNSYS Modeling of the SEGS VI parabolic trough solar electric generating system*” Proceedings of the Solar Forum 2001, Solar, Energy: The Power to Choose, Washington DC, 2001
- Khalifa, N. and Al-Mutawalli, S., “Effect of Two-axis Sun Tracking on the Performance of Compound Parabolic Concentrators”, *Energy Convers.Mgmt*, Vol. 39, No.10, pp. 1073-1079, 1998.
- Kızılırmak A., “*Gökbilim Dersleri, Küresel Bilim*”, Cilt 1, Ege Üniversitesi Basımevi, 1998.
- Kreider, J. and Kreith, F., “*Solar Energy Handbook*”, McGraw-Hill Book Company, 1991
- Mills , David R. and Morrison, Graham L., “*Advanced Fresnel Reflector Powerplants - Performance and Generating Costs*”, Proceedings of Solar '97 - Australian and New Zealand Solar Energy Society, Paper 84
- Taşdemiroğlu, E., “*Solar Energy Utilization; Technical and Economic Aspects*”, Middle East Technical University, 1990.

- Poulek, V. and Libra, M., *A Very Simple Solar Tracker for Space and Terrestrial Applications*, *Solar Energy Materials & Solar Cells*, 60, (2000), 99-103.
- Poulek, V. and Libra, M., *New Solar Tracker*, *Solar Energy Materials & Solar Cells* 51 (1998), 113-120.
- Reynolds, D. J et al., "*A Hydrodynamic Model for a Line-Focus Direct Steam Generation Solar Collector*", *Proceedings of Solar 2002 - Australian and New Zealand Solar Energy Society*, Paper 1
- Satcunanathan, S. et al., "The design and performance of a semi-tracking flat plate collector", *Proceedings of Solar World Congress*, Perth, 1983, pp. 757-761.
- Yüncü, H. et al., "*Solar Energy Utilization*", Martinus Nijhoff Publishers, 1987.