

A RESEARCH ON DESIGN OF HEATING,  
VENTILATION AND AIR CONDITIONING OF  
HYGIENIC SPACES IN HOSPITALS

A Thesis Submitted to  
the Graduate School of Engineering and Sciences of  
İzmir Institute of Technology  
in Partial Fulfillment of the Requirements for the Degree of

MASTER OF SCIENCE

in Mechanical Engineering

by  
Orkun Baki ANIL

December 2008  
İZMİR

We approve the thesis of **Orkun Baki ANIL**

---

**Assist. Prof. Dr. Moghtada MOBEDİ**  
Supervisor

---

**Prof. Dr. M. Barış ÖZERDEM**  
Co-Supervisor

---

**Assist. Prof. Dr. Tahsin BAŞARAN**  
Committee Member

---

**Dr. Tuğçe KAZANASMAZ**  
Committee Member

18 December 2008

---

**Assoc. Prof. Dr. Metin TANOĞLU**  
Head of the Mechanical  
Engineering Programme

---

**Prof. Dr. Hasan BÖKE**  
Dean of the Graduate School of  
Engineering and Sciences

## **ACKNOWLEDGEMENT**

I would like to express my gratitude to my advisor Assist. Prof. Dr. Moghtada Mobedi and my co-advisor Prof. Dr. Barış Özerdem for their invaluable advice, guidance, and encouragement.

I am also grateful to Geothermal Energy Research and Application Center at Izmir Institute of Technology for their support during my tests. I would also like to thank my colleagues at Genta for their encouragement, help and patience during my study. I would like to thank specially to Mr. Ferit Çömez for his invaluable help to my research.

I would also like to thank to Hygienic HVAC Commission, working under Izmir Branch of Chamber of Mechanical Engineers, for their confidence in me and for accepting me to the commission as one of them.

I am also grateful to my parents for their endless support during my thesis and all of my life.

## **ABSTRACT**

### **A RESEARCH ON DESIGN OF HEATING, VENTILATION AND AIR CONDITIONING OF HYGIENIC SPACES IN HOSPITALS**

There are various sterile spaces in hospitals which are highly at risk in terms of infection. HVAC systems play an important role on the infection risk in sterile spaces. HVAC systems for sterile spaces focus on number of particles, number and types of microorganisms, pressure difference between the sterile and its neighboring spaces, supply air velocity and air distribution in addition to the comfort parameters which are temperature, relative humidity and fresh air rate. Therefore, the design of HVAC systems for sterile spaces is more difficult and complicated compared to the comfort applications.

This study firstly reviews the design parameters of HVAC systems of sterile spaces in hospitals. A literature survey is conducted about the effects of the design parameters on infection transmission in sterile spaces. Also a literature survey on various standards and design guidelines for HVAC design parameters of sterile spaces used by different countries is performed. Secondly, an experimental study was conducted in an operating room to reveal the system performance during operation.

The reviewed standards and guidelines are compared via tables. The weak and strong points of the reviewed references are noted. Despite well known effects of HVAC systems on infection transmission, significant differences among standards and guidelines are observed. Based on the obtained experimental results, considerable differences of design parameters between “in operation” and “at rest” states were observed.

## ÖZET

### HASTANELERİN HİJYENİK ORTAMLARININ ISITMA, SOĞUTMA VE HAVALANDIRMASININ TASARIMINA İLİŞKİN BİR ARAŞTIRMA

Hastanelerde enfeksiyon açısından yüksek riskli bir çok steril mahal vardır. Klima ve havalandırma sistemleri steril mahallerdeki enfeksiyon riski üzerinde önemli bir rol oynamaktadır. Steril mahaller için kullanılan klima ve havalandırma sistemleri ısı, nem ve taze hava oranı gibi konfor parametrelerine ilaveten, partikül sayısı, mikroorganizma tipi ve sayısı, steril mahaller ve komşulukları arasındaki basınç farklılıkları, taze hava hızı ve hava dağılımı gibi parametrelere de yoğunlaşmaktadır. Bu sebeple, steril ortamlarda klima ve havalandırma uygulamaları konfor uygulamalarına nazaran çok daha zor ve karmaşıktır.

Bu çalışmada, ilk olarak hastanelerdeki hijyenik mahallerde bulunan klima ve havalandırma sistemlerinin tasarım parametreleri derlenmiştir. Yukarıda bahsedilen tasarım parametrelerinin steril mahallerdeki enfeksiyon kontrolü üzerindeki etkileri ile ilgili bir literatür araştırması yapılmıştır. Ayrıca steril mahallere hizmet veren klima ve havalandırma sistemleri uygulamaları için farklı ülkeler tarafından kullanılan çeşitli standartlar ve tasarım kılavuzları hakkında da bir araştırma yapılmıştır. İkinci olarak, operasyon esnasında klima ve havalandırma sisteminin performansını ortaya koymak amacıyla bir ameliyathanede deneysel bir çalışma gerçekleştirilmiştir.

Araştırılan standartlar ve kılavuzlar tablolar kullanılarak karşılaştırılmıştır, güçlü ve zayıf yönleri belirtilmiştir. HVAC sistemlerinin enfeksiyon üzerindeki etkileri çok iyi bilinmesine rağmen standart ve kılavuzlar arasında büyük farklılıklar olduğu görülmüştür. Deneysel çalışma sonucunda elde edilen verilere göre ameliyat odaları için çalışma ve bekleme şartlarında tasarım parametrelerinin değerlerinde oldukça büyük farklar olduğu gözlenmiştir.

# TABLE OF CONTENTS

LIST OF FIGURES .....	x
LIST OF TABLES.....	xiv
CHAPTER 1 INTRODUCTION .....	1
CHAPTER 2 TERMS AND DEFINITIONS .....	3
CHAPTER 3 HISTORICAL BACKGROUND OF STERILE SPACES IN HOSPITALS.....	11
CHAPTER 4 INFECTION CONCEPT AND ITS TRANSMISSION IN HOSPITALS.....	14
4.1. Infection Sources .....	14
4.2. Infection Transfer Modes.....	15
4.2.1. Direct Contact Transmission .....	15
4.2.2. Airborne Transmission .....	16
4.3. Measures for Reducing Contamination in Sterile Spaces.....	17
4.3.1. Staff-side Measures.....	17
4.3.2. Air-side Measures .....	18
CHAPTER 5 STERILE SPACES IN HOSPITALS.....	21
5.1. Operating Suite .....	21
5.1.1. Operating Room.....	22
5.1.2. Pre-op Room.....	23
5.1.3. Anesthesia Equipment Room.....	23
5.1.4. Post-op Room .....	23
5.1.5. Sterile and Soiled Equipment Rooms .....	24

5.2. Delivery Room.....	25
5.3. Intensive Care Units.....	25
5.4. Isolation Rooms .....	26
5.4.1. Positive Pressure Rooms.....	27
5.4.2. Negative Pressure Rooms .....	27
5.5. Central Sterile Services.....	28
CHAPTER 6 HVAC DESIGN PARAMETERS FOR STERILE SPACES .....	30
6.1. Temperature .....	30
6.2. Relative Humidity.....	31
6.3. Filtration.....	32
6.4. Air Velocity and Air Distribution.....	33
6.5. Pressurization.....	35
6.5.1. Volumetric Flow Rate.....	36
6.5.2. Room Differential Pressure .....	36
6.6. Total and Fresh Air Changes .....	36
CHAPTER 7 COMPARISON OF STANDARDS ON STERILE SPACES .....	37
7.1. Operating Suite .....	38
7.1.1. Operating Room.....	38
7.1.2. Pre-op and Post-op Rooms .....	44
7.2. Delivery Room.....	46
7.3. Intensive Care Unit.....	47
7.4. Positive Pressure Room .....	47
7.5. Central Sterile Services Department.....	50
CHAPTER 8 HVAC SYSTEM AND EQUIPMENT FOR STERILE SPACES IN HOSPITALS .....	52
8.1. Equipment.....	52
8.1.1. Air Handling Unit .....	52
8.1.1.1. Conventional Air Handling Units.....	54

8.1.1.1.1. Air Filters .....	54
8.1.1.1.2. Coils .....	54
8.1.1.1.3. Humidifier .....	55
8.1.1.1.4. Fan and Motor .....	55
8.1.1.1.5. Sound Attenuator .....	55
8.1.1.1.6. Air Handling Unit Casing .....	55
8.1.1.2. Packaged Air Handling Units .....	55
8.1.2. VAV Box .....	56
8.1.3. CAV Box.....	58
8.1.4. Duct Type Electrical Heater.....	59
8.1.5. HEPA Filter.....	59
8.1.6. HEPA Filter Box.....	59
8.1.7. Laminar Flow Unit.....	60
8.1.8. Lint Grilles .....	61
8.2. Types of HVAC Systems Serving to Sterile Areas .....	62
8.2.1. One-to-One Systems .....	62
8.2.2. Multiple Space Systems .....	63
8.3. HVAC Systems for Service Rooms in an Operating Suite.....	64

## CHAPTER 9 AN EXPERIMENTAL STUDY ON DESIGN PARAMETERS

OF AN OPERATING ROOM.....	66
9.1. Acceptance Tests and Validation of a System.....	66
9.1.1. As Built .....	67
9.1.2. At Rest.....	67
9.1.3. In Operation .....	68
9.2. Purpose of the Present Experimental Study.....	68
9.3. Equipments Used for the Experiments .....	70
9.3.1. Particle Counter.....	70
9.3.2. Data Logger.....	71
9.3.3. Air Temperature Transducer.....	73
9.3.4. Humidity Transducer .....	73



9.3.5. Air Velocity Transducer.....	74
9.4. Procedure of the Performed Experiments.....	75
9.5. Results.....	79
9.5.1. October 23 <sup>rd</sup> .....	80
9.5.2. October 24 <sup>th</sup> .....	87
9.5.3. October 25 <sup>th</sup> and 26 <sup>th</sup> .....	93
9.5.4. October 27 <sup>th</sup> .....	105
9.5.5. October 28 <sup>th</sup> .....	111
9.5.6. October 29 <sup>th</sup> and 30 <sup>th</sup> Sterile Corridor.....	117
CHAPTER 10 CONCLUSION .....	123
REFERENCES .....	127

## LIST OF FIGURES

<u>Figure</u>	<u>Page</u>
Figure 3.1. Section through Charnley's original system .....	13
Figure 5.1. View from operating room .....	22
Figure 5.2. Pre-op room .....	23
Figure 5.3. Post-op Room .....	24
Figure 5.4. Intensive Care Unit.....	26
Figure 5.5. View from central sterile services department sterile storage area .....	29
Figure 6.1. Turbulent air flow distribution .....	33
Figure 6.2. Laminar air flow distribution .....	34
Figure 8.1. Schematic (a) and photographic (b) views of a hygienic air handling unit.....	53
Figure 8.2. Packaged air handling unit .....	56
Figure 8.3. Schematic (a) and photographic (b) views of a VAV box .....	57
Figure 8.4. Schematic (a) and photographic (b) views of a CAV box .....	58
Figure 8.5. HEPA filter.....	59
Figure 8.6. Swirl and square diffusers and HEPA filter boxes.....	60
Figure 8.7. Schematic view of a laminar air flow unit with recirculation air .....	61
Figure 8.8. Lint grille.....	62
Figure 8.9. Schematic view of a one-to-one system .....	63
Figure 8.10. A schematic view of a multiple system.....	64
Figure 8.11. A schematic view of the HVAC system for sterile spaces in an operating suite.....	65
Figure 9.1. General view from the operating room .....	69
Figure 9.2. Laminar air flow unit installed in the room.....	70
Figure 9.3. Climet CI-450t particle counter.....	71
Figure 9.4. INNOVA 1221 data logger and certain transducers .....	72
Figure 9.5. MM0034 air temperature transducer .....	73
Figure 9.6. MM0037 humidity transducer.....	74
Figure 9.7. MM0038 air velocity transducer .....	75
Figure 9.8. Schematic view of the operating room.....	76

Figure 9.9. Schematic view of the HVAC system serving to the operating room.....	76
Figure 9.10. Schematic view of the operating suite showing the locations of the sterile corridor and the operating room used for the measurements.....	77
Figure 9.11. Data logger, transducers and particle counter in operating room environment .....	77
Figure 9.12. Measurement devices in sterile corridor .....	78
Figure 9.13. Room and supply air temperature values of operating room on October, 23 <sup>rd</sup> .....	82
Figure 9.14. Relative humidity values of room and supply air on October 23 <sup>rd</sup> .....	83
Figure 9.15. Air velocity in the operating room, October 23 <sup>rd</sup> .....	84
Figure 9.16. 0.3 micron particle count, October 23 <sup>rd</sup> (counts/liter) .....	85
Figure 9.17. 0.5 micron particle count, October 23 <sup>rd</sup> (counts/liter) .....	86
Figure 9.18. 1.0 micron particle count, October 23 <sup>rd</sup> (counts/liter) .....	86
Figure 9.19. 5.0 micron particle count, October 23 <sup>rd</sup> (counts/liter) .....	87
Figure 9.20. Room and supply air temperature values of operating room on October, 24 <sup>th</sup> .....	88
Figure 9.21. Relative humidity values of room and supply air on October 24 <sup>th</sup> .....	89
Figure 9.22. Air velocity in the operating room, October 24 <sup>th</sup> .....	90
Figure 9.23. 0.3 micron particle count, October 24 <sup>th</sup> (counts/liter) .....	91
Figure 9.24. 0.5 micron particle count, October 24 <sup>th</sup> (counts/liter) .....	92
Figure 9.25. 1.0 micron particle count, October 24 <sup>th</sup> (counts/liter) .....	92
Figure 9.26. 5.0 micron particle count, October 24 <sup>th</sup> (counts/liter) .....	93
Figure 9.27. Room and supply air temperature values of operating room on October, 25 <sup>th</sup> .....	94
Figure 9.28. Relative humidity values of room and supply air on October 25 <sup>th</sup> .....	95
Figure 9.29. Air velocity in the operating room, October 25 <sup>th</sup> .....	96
Figure 9.30. 0.3 micron particle count, October 25 <sup>th</sup> (counts/liter) .....	97
Figure 9.31. 0.5 micron particle count, October 25 <sup>th</sup> (counts/liter) .....	98
Figure 9.32. 1.0 micron particle count, October 25 <sup>th</sup> (counts/liter) .....	98
Figure 9.33. 5.0 micron particle count, October 25 <sup>th</sup> (counts/liter) .....	99

Figure 9.34. Room and supply air temperature values of operating room on October, 26 <sup>th</sup> .....	100
Figure 9.35. Relative humidity values of room and supply air on October 26 <sup>th</sup> .....	101
Figure 9.36. Air velocity in the operating room, October 26 <sup>th</sup> .....	102
Figure 9.37. 0.3 micron particle count, October 26 <sup>th</sup> (counts/liter) .....	103
Figure 9.38. 0.5 micron particle count, October 26 <sup>th</sup> (counts/liter) .....	103
Figure 9.39. 1.0 micron particle count, October 26 <sup>th</sup> (counts/liter) .....	104
Figure 9.40. 5.0 micron particle count, October 26 <sup>th</sup> (counts/liter) .....	104
Figure 9.41. Room and supply air temperature values of operating room on October, 27 <sup>th</sup> .....	106
Figure 9.42. Relative humidity values of room and supply air on October 27 <sup>th</sup> .....	107
Figure 9.43. Air velocity in the operating room, October 27 <sup>th</sup> .....	108
Figure 9.44. 0.3 micron particle count, October 27 <sup>th</sup> (counts/liter) .....	109
Figure 9.45. 0.5 micron particle count, October 27 <sup>th</sup> (counts/liter) .....	110
Figure 9.46. 1.0 micron particle count, October 27 <sup>th</sup> (counts/liter) .....	110
Figure 9.47. 5.0 micron particle count, October 27 <sup>th</sup> (counts/liter) .....	111
Figure 9.48. Room and supply air temperature values of operating room on October, 28 <sup>th</sup> .....	112
Figure 9.49. Relative humidity values of room and supply air on October 28 <sup>th</sup> .....	113
Figure 9.50. Air velocity in the operating room, October 28 <sup>th</sup> .....	114
Figure 9.51. 0.3 micron particle count, October 28 <sup>th</sup> (counts/liter) .....	115
Figure 9.52. 0.5 micron particle count, October 28 <sup>th</sup> (counts/liter) .....	116
Figure 9.53. 1.0 micron particle count, October 28 <sup>th</sup> (counts/liter) .....	116
Figure 9.54. 5.0 micron particle count, October 28 <sup>th</sup> (counts/liter) .....	117
Figure 9.55. 0.3 micron particle count in sterile corridor, October 29 <sup>th</sup> (counts/liter).....	118
Figure 9.56. 0.5 micron particle count in sterile corridor, October 29 <sup>th</sup> (counts/liter).....	118
Figure 9.57. 1.0 micron particle count in sterile corridor, October 29 <sup>th</sup> (counts/liter).....	119

Figure 9.58. 5.0 micron particle count in sterile corridor, October 29 <sup>th</sup> (counts/liter).....	119
Figure 9.59. 0.3 micron particle count in sterile corridor, October 30 <sup>th</sup> (counts/liter).....	120
Figure 9.60. 0.5 micron particle count in sterile corridor, October 30 <sup>th</sup> (counts/liter).....	121
Figure 9.61. 1.0 micron particle count in sterile corridor, October 30 <sup>th</sup> (counts/liter).....	121
Figure 9.62. 5.0 micron particle count in sterile corridor, October 30 <sup>th</sup> (counts/liter).....	122

## LIST OF TABLES

<b><u>Table</u></b>	<b><u>Page</u></b>
Table 7.1. Recommended values for HVAC design parameters for operating rooms.....	41
Table 7.2. Recommended HVAC design parameters for pre- and post-operative rooms .....	45
Table 7.3. Suggested HVAC Design parameter values for delivery operating rooms.....	45
Table 7.4. Recommended minimum design values for HVAC systems of intensive care units.....	48
Table 7.5. Recommended design parameters of HVAC systems for isolation rooms .....	49
Table 7.6. Recommended HVAC design parameters for central sterile services and sterile equipment stores .....	51
Table 9.1 Occupancy timetable of tested operating room .....	80

# CHAPTER 1

## INTRODUCTION

Hospitals require secure HVAC installations to protect both patients and hospital staff from irreversible infections. There are various sterile spaces in hospitals which are highly at risk in terms of infection. HVAC systems play an important role on the infection risk in sterile spaces. HVAC systems for comfort applications focus on three parameters which are temperature, relative humidity and fresh air rate. However; additional parameters as number of particles, number and types of microorganisms, pressure difference between the sterile and its neighboring spaces, supply air velocity and air distribution have to be considered in the HVAC system of sterile spaces. Therefore, the design of HVAC systems for sterile space applications is more difficult and complicated compared to the comfort applications.

The aim for using sterile air in hospital spaces is creating a germ-free environment and keeping this sterile environment conditions steady for all patients and hospital staff. This sterile environment reduces the risk of infection transmission from patient to patient or from patient to hospital staff. Also, the risk of surgical site infection is reduced by this approach. HVAC system of sterile spaces must satisfy various design conditions such as thermal comfort and sterilized indoor air. The air of sterile spaces must be aseptic and it should be with low velocity and at constant temperature and relative humidity.

Due to importance of HVAC systems on infection control studies have been performed by many researchers in recent years. Balaras et al. (2007) focused on energy audit of Hellenic hospitals and reviewed the similar studies very successfully. Smyth et al. (2005) performed an investigation on operating theater ventilation facilities for minimally invasive surgery in Great Britain and Northern Ireland. In their study, five hundred and fifty questionnaires were forwarded to HIS members (Hospital Infection Society Working Party on Infection Control in Operating Theatres) and 186 (39%) replies were received. Based on the performed evaluation, it is declared that large-scale clinical trials, which are difficult to perform, must be conducted to determine what

standards of ventilation are appropriate to minimize infection risk. Another study of HIS reported by Humphreys and Taylor is on the operating theater ventilation standards and the risk of postoperative surgery. They declared that there are no clear guidelines on the optimal operating theater facilities for minimally invasive surgery (Humphreys and Taylor 2002). The study of Dharan and Pittet proposes that the reduction in the number of particles in an operating room decreases the number of infections for orthopedic surgery. Therefore, the study suggests using particle counts instead of microbiological sampling (Dharan and Pittet 2002). Opposing to this argument, the study of Landrin et al. (2005), which involves particle and microbiological sampling in four conventionally ventilated operating rooms over three months, shows that there is no correlation between particle count and microbiological contamination. But it is accepted that the microbiological contamination is significantly correlated with the particle size of 5-7 microns for ultra clean (having laminar flow distribution profile) operating rooms. In additions to these studies, the recent improvements on computational fluid dynamics encourage researchers to theoretically determine air velocity and particle distribution in the operation and isolation rooms. The scope of this study does not contain this computational studies but a lot of reports can be found in literature easily.

HVAC systems serving to sterile spaces of hospitals must satisfy various design conditions specific to different spaces. HVAC system serving sterile areas must supply sufficient amount of clean and germ-free air along with the pressurization characteristics and demanding temperature and relative humidity requirements.

This study investigates the importance of the sterile HVAC applications and reviews the design parameters of HVAC systems of sterile spaces in hospitals. A literature survey of various standards and design guidelines used by different countries on HVAC design parameters of sterile spaces has been conducted. Moreover, a literature survey about the effects of design parameters on infection transmission is performed.

Also an experimental study was performed to reveal the transient behavior of HVAC design parameters in sterile spaces of hospitals. In order to achieve this, continuous measurements of temperature, relative humidity, air velocity and particle concentration were conducted in an operating room and a sterile corridor. The changes of these parameters with respect to time and occupancy characteristics of the rooms were investigated.



## CHAPTER 2

### TERMS AND DEFINITIONS

In this chapter, terms and definitions used throughout this study and general definitions are discussed. Terms and definitions are listed alphabetically. The aim of this list is to familiarize the reader to the study. The given terms and definitions are based on the related chapter from ASHRAE's HVAC Design Manual for Hospitals and Clinics (American Society of Heating Refrigerating and Air-Conditioning Engineers 2003).

**Age of air** is the time that has elapsed after the air enters a space (at any given point). When recirculated air is supplied to a room, the freshness of air and its dilution capability are characterized by its age.

**Airborne**; something in flight, carried by air.

**Air change rate** is the airflow in volume units per hour divided by the building space volume in identical volume units (abbreviated as ACH or ACPH).

**Air cleaning system** is a device or combination of devices used to reduce the concentration of airborne contaminants, such as microorganisms, dusts, fumes etc.

**Air conditioning process** in enclosed spaces is a combined treatment of the air to control temperature, relative humidity, velocity of motion and radiant heat energy level, including consideration of the need to remove airborne particles and contaminant gases.

**Air conditioning system** is the assembly of equipment for air treatment to control simultaneously its temperature, humidity cleanliness and distribution to meet the requirements of a conditioned space.

**Air irritant** is a particle or volatile chemical in air that causes a physiological response when in contact with mucosa in the eye, nose or throat.

**Air volume migration** is the volume of air that is exchanged during room entry/exit.

**Airborne contaminant**, an unwanted airborne constituent that may reduce the acceptability of air.

**Airborne droplet nuclei** is a small particle residue (5 µm or smaller) of evaporated droplets containing microorganisms that remain suspended in air and can travel by air currents over a long distance. Generally this particle is formed after the evaporation of an original particle up to 150 µm in diameter. Depending on the origin of the particle, it may be infectious.

**Airborne infection isolation room** is a room designed with negative pressurization to protect patients and people outside the room from the spread of microorganisms that exist in the patient inside the room. Common airborne infectious agents are measles, tuberculosis and chicken pox.

**Airborne infectious agent** is an airborne particle which can cause infection.

**Airborne pathogen** is an airborne particle that can cause disease. These particles are infectious organisms or chemicals that can produce disease in a susceptible host.

**Anteroom** is a room separating an isolation room from a corridor.

**Asepsis**, a condition of being free from microbes; free from infection, sterile free from any form of life. Also, **sepsis** means an infected condition and **antiseptics** is the action to eliminate microbes and infection.

**Bioaerosol** means particles or droplets suspended in air that consist of or contain biological matter such as bacteria, pollens, fungi, skin flakes and viruses.

**Birth rooms** (also **LDR** (Labour/Delivery/Recovery) or **LDRP** (Labour/Delivery/Recovery/Post-partum) are a specialized version of a single-patient room. If the patient stays in the same room until giving birth, the space is called as LDRP. These areas are for normal births. If the birth gets complicated, the patient is transferred to a delivery room.

**Building air infiltration** is the uncontrolled inward leakage of air through cracks and interstices in any building element and around windows and doors of a building, caused by the pressure effects of wind or the effect of differences in the indoor and outdoor air density.

**Community acquired infection** is an infection present or incubating in a patient upon admission to a hospital.

**Clean Steam** is the steam for humidification and/or sterilization that is generated in a system without chemical additives.

**Contaminant** (also as pollutant), any impurity, any material of an extraneous nature, associated with a chemical, a pharmaceutical preparation, a physiologic principle or an infectious agent.

**Contamination** is the act of contaminating, especially the introduction of disease germs or infectious material into or on normally sterile objects. Concentration of contaminants in the air leads to contamination of living tissue, which leads to colonization and consequently to infection and disease.

**Control (HVAC&R)** compensates two different meanings. First meaning is a device for regulating a system or component in normal operation, manually or automatically and second is the methods and means of governing the performance of any apparatus, machine or system.

**Control (medical)**; method to eradicate or improve a disease process (treatment and/or public health measures).

**Delivery room** is a room identical to a general operating room. These rooms are primarily used for cesarean deliveries (C-sections), breech births or other complicated deliveries.

**Design conditions** are the values of ventilation, temperature and humidity within which a system is designed to operate to provide conditioned air. Also, filtering levels may be required.

**Diagnostic clinic** is a facility where patient are regularly seen on an ambulatory basis for diagnostic services or minor treatment but where major treatment requiring general anesthesia or surgery is not performed.

**Dialysis** is an external method of adjusting the levels of ions and chemicals in the blood, replacing the original process normally performed by the kidneys.

**Dedicated equipment connection (utilities)** is the connections for water, waste, steam, medical gases, chilled water and electricity. Some medical and hospital equipment requires a dedicated supply main utility connection, separated from utilities supplied to the general area.

**Endoscopy**, a general term meaning the visualization of body cavities and structures through an inserted optical instrument.

**Endoscopy area** is the environment for endoscopy. Some specific endoscopic procedures require anesthesia and are performed in an operating room or an endoscopy room equipped for anesthesia.

**Epidemiology** is the study of the distribution and determinants of disease. This is not limited to infectious diseases; it also includes all human illnesses like cancer and metabolic diseases.

**(Emergency) Exam rooms** these rooms (named also as treatment rooms) are used for emergency treatment of broken bones, lacerations, foreign objects, concussions, etc. These rooms provide services to treat the injury of illness and then to discharge the patient or to stabilize the patient for further observation or treatment as hospitalized patient.

**Exhaust air** is the air removed from a space and discharged outside of the building by mechanical or natural ventilation systems.

**Exfiltration** is the air leakage outward through cracks and interstices, and through ceilings, floors and walls of a space or building.

**Hematology** is the study of blood and blood forming tissues and the disorders associated with them.

**HEPA filter**, also known as absolute filter, is a high efficiency particulate air filter. HEPA filter has removal efficiencies of 99.97% or higher of particulates larger than 0.30 microns.

**Hygiene** means the application of scientific knowledge to the preservation of health and prevention of the spread of diseases.

**Immunocompromised host**, sometimes as immunosuppressed host, is an individual whose immune system has been weakened by disease or medical treatment such as AIDS or chemotherapy.

**Immunocompromised infectious host** is a patient who is both an immunocompromised host and a potential transmitter of infection.

**Indoor air quality** means the composition and characteristics of the air in an enclosed space that affect the occupants of that space. The indoor air quality of a space is determined by the level of indoor air pollution and other characteristics of the air, including those that impact thermal comfort, such as air temperature, relative humidity, and air speed. Indoor air quality in health care settings must incorporate considerations for infectious and other airborne contaminants. The HVAC or ventilation system should provide outdoor air ventilation to provide dilution ventilation, reduce airborne particulates in the recirculated portion of the ventilation air via filtration and have filtration capabilities suitable for the contaminants of concern, and provide special airflows such as for operating rooms.

**Infiltration** is the air leakage inward through cracks and interstices, and through ceilings, floors and walls of a space of a building.

**Intensive care rooms** are the rooms in which the level of patient care and electronic monitoring of patients are greatly increased over conventional patient rooms.

**Intensive care units** houses seriously ill patients receiving maximum care. This patient care unit is the best the hospital has to offer in terms of personnel and technology.

**Invasive procedure** is the insertion of an instrument or device into the body through an opening on the skin or body cavity for diagnosis or treatment. Surgery is a typical invasive procedure. However, when there is minimal damage on tissues at the point of entrance to the body, the procedure is called minimally invasive. This procedure involves special devices or remote controlled instruments used with observation of the surgical site via endoscopes or similar devices (Wikipedia Contributors 2008).

**Laboratory** is a location equipped to perform tests and experiments and to investigate procedures and for preparing reagents, therapeutic chemicals and radiation. Major laboratories include chemistry, hematology, microbiology and pathology.

**Local exhaust (local ventilation exhaust)** operate on the principle of capturing an airborne contaminant or heat at or near the source.

**Makeup air** is the combination of outdoor and transfer air intended to replace exhaust air and exfiltration.

**Medical equipment** is the equipment specific to a medical procedure or activity. Some examples are the specialized equipment in departments such as diagnostic radiology, therapeutic radiology, clinical laboratory, pharmacy, administration, central sterile processing, surgery, emergency, and laser surgery.

**Medical gas** includes oxygen, nitrogen, nitrous oxide, vacuum and medical compressed air. Vacuum and anesthetic gases are typical medical gases used throughout hospitals.

**Minor surgery** is an operation in which a body cavity is not entered or in which a permanent device is not inserted.

**Mycosis** means any disease caused by fungi.

**Nosocomial infection (hospital-acquired infection)** is the infection that is acquired in a hospital and that was not present or incubating upon admission.

**Occupiable space** is an enclosed space intended for human activities, excluding those spaces intended primarily for other purposes (such as storage rooms and equipment rooms).

**Occupationally acquired infection** is the infection acquired while working in a medical setting.

**Operating room** is a room specifically designed for surgical procedures which means most types of surgical procedures, especially those that involve administration of anesthesia, multiple personnel, recovery room access and a fully controlled environment. Some operating rooms may be used for special operations like cardiac transplant operating rooms which are used for heart bypass surgery and neurosurgery operating rooms which are used for brain and/or spinal surgery. A cardiac operating room is similar to general operating rooms but normally require larger room space because more equipment is needed. Neurosurgery operating room has ceiling-mounted microscope equipment and viewing equipment.

**Opportunistic microorganism** describes an ordinarily noninfectious agent that becomes infectious in an immunocompromised host.

**Outdoor air** has two different meanings. First, it means the air outside of a building or taken from the outdoors and not previously circulated through the system. Second meaning is the ambient air that enters a building through a ventilation system, through intentional openings for natural ventilation, or by infiltration.

**Patient rooms** are normally semiprivate (two patients) or private (individual patients). Each patient room is provided with a private toilet and shower. Patient care is provided for recuperation from a procedure, patient observation and diagnosis. Rooms are normally contained within a department and supervised by an individual or by multiple nursing stations. A medicine preparation/dispensing area, clean and soiled linen and holding areas, housekeeping support and staff facilities complement each department.

**Pollutant** is an undesired contaminant that results in pollution. A pollutant may or may not be an infectious agent.

**Pollution** is defined as unclean or unsuitable by contact or mixture with an undesired contaminant.

**Pressurization** is a difference in pressure between a space and a reference pressure. Pressurization is important for infection control. Positive pressurization produces a net flow of room air out of a space toward the reference space through any

opening between the two spaces. Negative pressure produces a net flow of air into a space from the reference space by the same way.

**Procedure** is the treatment of a patient. Invasive and minimally invasive procedures are performed in operating rooms.

**Protective environment room** is a patient care setting that requires positive pressurization to protect the patient from human and environmental airborne diseases. This protection is needed for patients who are immunocompromised either from disease or from treatment.

**Recirculated air** is the air removed from a space and reused as supply air.

**Room air distribution effectiveness** is a measure of how effective is the ventilation system to maintain acceptable air quality in the room.

**Sealed room** is a room that has minimal leakage to prevent infiltration and exfiltration.

**Skin squame** is a small flake of epidermal skin tissue.

**Sterile** is the condition of being free from all living microorganisms and their spores.

**Sterile field** is a designated sterile surface in and around an invasive procedure site. The following are considered as the boundaries of the sterile field in surgery;

- The surface of the sterile drapes down to the level of the operating room table. The arms and gloves of the staff are considered to be in the sterile field.
- The fronts of the gowns of the operating personnel from the neck lines to the level of the table.
- Equipment that is properly draped.
- Portions of properly draped equipment, such as properly draped microscopes and X-ray machines.
- The light handles, but not the lights.
- The anesthesia screen from the level of the table up to the top of the screen.

**Supply air** is the air delivered by mechanical or natural ventilation to a space that is composed of any combination of outdoor air, recirculated air or transfer air.

**Thermal surgical plume** is a convection current of air rising from the wound site due to the body heat of patient, operating room personnel and radiant heat from the surgical light.

**Transfer air** is the air moved from one indoor space to another.

**Treatment** is the activities taken to eradicate or ameliorate a patient's disease.

**Ultraviolet irradiation (UV)** is that portion of the electromagnetic spectrum described by wavelengths from 100 to 400 nm.

**Ultraviolet germicidal irradiation (UVGI)** is that portion of the electromagnetic spectrum described by wavelengths from 200 to 270 nm. UVGI is the use of UV radiation to kill or inactivate microorganisms.

**Ventilation** is the process of supplying air to or removing air from a space for the purpose of controlling air contaminant levels, humidity or temperature within the space. The air may not have been conditioned before supplying to the space. **Mechanical ventilation** is ventilation provided by mechanically powered equipment such as fans and blowers, not such as wind-driven turbine ventilators and mechanically operated windows. **Natural ventilation** is provided by thermal, wind or diffusion effects through doors, windows or other intentional openings in the building.

**Ventilation efficiency** is the ability of a system to remove contaminants generated by a source in a room.

**Waste anesthetic gas** is the gas that has been delivered to the patient and is exhaled or the excess amount of gas consumed by the patient.



## **CHAPTER 3**

### **HISTORICAL BACKGROUND OF STERILE SPACES IN HOSPITALS**

In the 18<sup>th</sup> century, there were dedicated operating rooms that were built to facilitate the teaching of surgery. The surgeries were completed without any kind of contamination control at all. Lord Lister realized that bacteria causes surgical site infections and elimination of bacteria from the room air should prevent infection. In 1860s he reduced infection in his operating room at the Royal Infirmary, Glasgow by use of an antiseptic solution that kills bacteria.

The operations were carried out without the use of protective garments at that time. The gown used by the surgeon was not meant to protect the patient but the surgeon from the blood. The protective wear is improved in time. In 1890s surgeons were wearing gowns but not gloves, hats or masks and little was known of contamination control. By the end of the 19<sup>th</sup> century, boiling of equipments and steam sterilized gloves, masks and gowns were introduced.

Until 1940s mechanical ventilation was being used in hospitals rarely, and it was for comfort not for contamination control. Ventilation of rooms and aerodynamics of particles were studied during the Second World War. As a result, mechanical ventilation applications were started being used for contamination control. Since microbiological warfare was a threat, airborne dispersion of microorganism was also studied and airborne microbiological sampler was invented. After the Second World War, the problems of airborne infection in crowded hospitals were studied.

By the beginning of 1960s, most of the principles about the performance of turbulently ventilated rooms were known. Also the facts that the people were the source of airborne bacteria that disperses from the people's skin, and tightly woven protective fabrics were required to prevent the dispersion of skin squames and microorganisms from the skin was also known (Whyte 2001).

In 1955 Blowers et al. had found high levels of airborne bacteria in a theatre during the investigation of a rise in the incidence of postoperative wound infections in a thoracic surgery unit. The system was found faulty and after the faults in the ventilation system had been removed with some other changes in procedure, the result was a decrease in infection rate by half. Shooter et al. had proposed that in new operating rooms, ventilation requirements would be best met by delivering air from multiple ceiling vents over the operating table to produce a downward air flow and the extract fans would be placed in the walls at floor level (Stacey and Humphreys 2002).

In 1960, the first application of unidirectional flow was constructed by Blowers and Crew in an operating room in Middlesborough in England after a series of field studies and a dummy theater examining the effects of various patterns of air distribution. The study of Blowers and Crew had recommended adjusting the air pressure difference between the rooms to encourage airflow from cleaner to dirtier zones in the operating suite and unidirectional flow was also recommended over turbulent flow (Stacey and Humphreys 2002). In the unidirectional flow operating room application, the air is supplied to the room by an air diffuser that is fitted over the entire ceiling of the room. The disturbance created by the movement of people and thermal currents of people and operating room lamp had prevented the unidirectional flow of the air. To overcome this problem, Professor Sir John Charnley, a pioneer in hip replacement surgery, developed an airflow system to improve the downward movement of air in 1961. The air was supplied through a “greenhouse” instead of whole ceiling of the room. The greenhouse area was 2.1m x 2.1m and it was placed within the operating room. The section of the airflow system developed by Charnley is given in Figure 3.1. The improvements were done on the airflow system designed by Charnley in time along with the improvements that were done on the fabric and design of the clothing used in operating rooms. This resulted with a decrease in airborne bacteria. As a result of this decrease, the deep hip infection rate of the surgeries he completed was reduced from 10% (1959) to less than 1% (1970). In 1980s, it is approved that the use of unidirectional flow with occlusive clothing reduces the joint sepsis with respect to that found in turbulently ventilated operating rooms by Medical Research Council of the United Kingdom. (Whyte 2001)

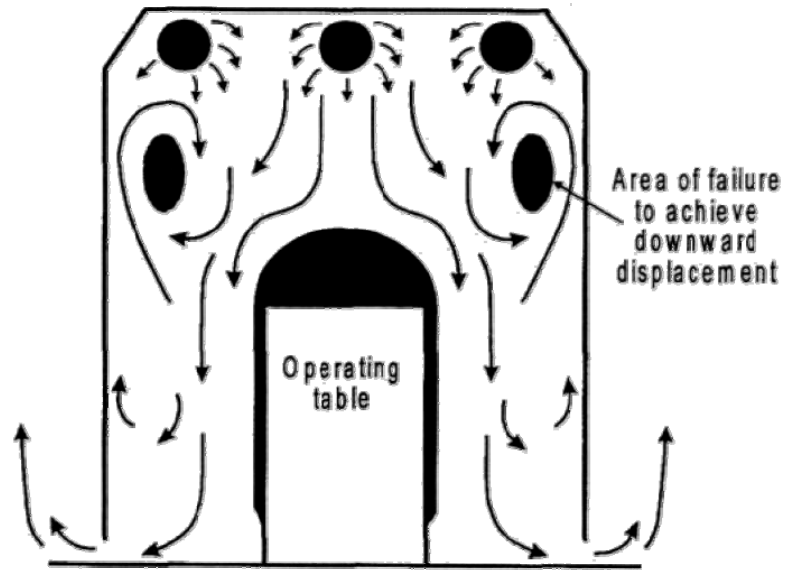

Figure 3.1. Section through Charnley's original system  
(Source: Whyte 2001)

## **CHAPTER 4**

### **INFECTION CONCEPT AND ITS TRANSMISSION IN HOSPITALS**

Hospital acquired infection or nosocomial infection is that were neither present nor incubating at the time the patient was admitted to the hospital. The majority of hospital acquired infection becomes evident in 48 hours or more following the admission of the patient. In some cases, the infection becomes evident after the discharge of the patient (World Health Organization Regional Office for South-East Asia 2002).

The basic need for using sterile air in hospital spaces is creating a germ-free environment and keeping this sterile environment conditions steady for all patients and hospital staff. This sterile environment reduces the risk of infection transmission from patient to patient, patient to hospital staff or staff to patient.

As one can see, there are various sources of infection. In this chapter, these sources and protective measures are discussed. Also the history of cleanroom and hygiene concept of air is summarized and a summary on the reviewed literatures are given.

#### **4.1. Infection Sources**

The primary source of infectious organisms in a health care facility is the patient having a contagious disease. Some examples of this kind of spreading infections are salmonellosis, group A streptococcal infections, tuberculosis, viral hepatitis etc (World Health Organization Regional Office for South-East Asia 2002). Other sources of infectious organisms include the microorganisms carried on every human, contamination of inside or outside air or water that is supplied to a space, or the microorganism growth inside the building or the HVAC system.

The microorganisms living on humans can be carried by the particles shed from the skin. A person sheds into the environment almost 1000 particles in an hour without moving (American Society of Heating Refrigerating and Air-Conditioning Engineers 2003). The number of particles released to environment increases as the movement rate of the person increases. In addition to this, hundreds of thousands of microbiologically contaminated particles can be generated by a single sneeze, cough or just loud speaking.

## **4.2. Infection Transfer Modes**

Infection can be transferred by two primary means which are direct contact and airborne transmission. The most common type of transmission of infectious organisms is direct contact transmission. Below, both transmission modes are explained in details.

### **4.2.1. Direct Contact Transmission**

When the pathogen enters the body through a wound, open sore or a vulnerable body part like mouth, eyes etc, via contact with unwashed hands, infectious body fluids or other infected objects or material, that is called direct contact transmission.

Direct contact transmission may occur following the contact of unwashed hands that have had contact with an infectious sources such as an ill patient, a contaminated equipment etc. with a susceptible host. Also a vulnerable body part may have contact with infectious body fluids such as an accidental splash of contaminated specimen in a laboratory. A rarely seen example for direct contact transmission is the transfer of infectious organisms by bite of an insect (such as mosquito or fly). This mode of direct contact transmission is most not applicable to hospitals most of the time (Victorian Advisory Committee on Infection Control 2007).

A single sneeze can produce 100 000 aerosolized particles and coughing can produce on the order of 10 000 particles per minute. Many of these droplets created by sneeze or cough are greater than 5 microns which causes them to settle in a radius of several feet. Therefore the spread of a contagious disease from a patient is limited to this radius. Even the spread of the infection is limited the contact with these infected droplets can lead to infection of other people.

Direct contact transmission has the biggest role in the spread of infection in a hospital and the cause of this is the unwashed hands of health care providers (American Society of Heating Refrigerating and Air-Conditioning Engineers 2003).

#### **4.2.2. Airborne Transmission**

Airborne transmission occurs by the respiration of particles or aerosols of sizes 1.0 to 5.0 microns which can remain airborne indefinitely. Infectious microorganisms are generally transported by the dust and particles (skin cells, soot, airborne droplet nuclei etc.). Particles or aerosols of sizes 1.0 to 5.0 microns can remain airborne indefinitely. Particles of this size can easily be respired deeply into the lungs and where in a susceptible host of in high enough concentration of microorganisms the host can become infected.

When an infected person sneezes, coughs or talks, particles light enough to remain suspended in air are generated. The respiration of these particles can result with the spread of the disease. Another source for airborne transmission is the microorganisms carried on human skin squames. These particles can be respired too, and can result with the infection of the host. Also, abrasive processes during surgical or autopsy procedures create aerosolized particles which may carry microorganism (American Society of Heating Refrigerating and Air-Conditioning Engineers 2003).

Aerosolization of contaminated water in spray humidifiers or evaporative cooling equipment of HVAC system is another way to spread infection by airborne route. In this process, the HVAC systems role is important on infection transfer. The contaminated aerosols can easily be distributed all of the building by the HVAC system. Also the reproduction of microorganisms within HVAC airflow equipment is another risk factor. Especially areas where moisture and dirt can accumulate such as cooling coil drain pans, wet filters, etc. must not be ignored.

The HVAC system is most effective on the airborne infection transmission as a part of the infection control process and if the HVAC system is infected, it becomes too easy for HVAC system to distribute this infection.

### **4.3. Measures for Reducing Contamination in Sterile Spaces**

Hospital acquired infections are considered as major sources of mortality and emotional stress in patients. These infections also add significant amount of economic loss to the budget of health care facilities. It is estimated that in any time, over 1.4 million people worldwide suffer from infectious complications that is acquired in hospital (World Health Organization Regional Office for South-East Asia 2002).

Measures for reducing the contamination in sterile spaces can be investigated under two classes which are staff-side measures and air-side measures. Staff-side measures are generally conducted during the activities in places where hygiene is required. Air-side measures are considered during the design or construction phases of heating ventilation and air conditioning systems serving to these spaces.

#### **4.3.1. Staff-side Measures**

The personnel working in sterile environment sheds skin squames or other particles during their activity. To reduce the amount of particle that is released into the environment, staff must wear protective garments. These garments include gowns, masks, gloves, hair and foot coverings etc. These protective garments are generally non-woven textile and when the protective garments are used, the risk of infection transfer from the patients or the environment to the staff is reduced, while the infection transfer risk from the staff to the ambient is reduced as well.

Another factor to increase the contamination is the movement of the staff in the environment. To reduce this contamination, the movement rate of the staff must be reduced as much as possible. By reducing the movement of the staff in the sterile environment, resuspension of settled dust is avoided. Also the shedding of particles from the staff is reduced by reducing the movement. The entrance and exit to/from a sterile environment must be reduced as well. This way, the entrance of particles from adjacent less clean spaces is prevented. The key method for reducing the movement and entrance of the personnel is reducing the staff employed in the sterile area (Dharan and Pittet 2002 and Neil, et al. 2005). Also facility floor and circulation plans must be designed to minimize the traffic between dirty and clean areas (American Society of Heating Refrigerating and Air-Conditioning Engineers 2003).

One of the measures that must be fulfilled by the staff is that the maximum care should be given to the sterile equipments that will touch the infectious source, such as the patient. The equipments that will be dismissed upon use must be sent to disposal and reusable equipments must be sent to sterilization as soon as possible. Separate storage of contaminated and clean materials must be provided. Surgical, medical treatment and invasive diagnostic instruments, appliances and materials must undergo sterilization and high level disinfection. These instruments must be protected from contamination until use. Room and fixed equipment surfaces in surgical and other invasive treatment or diagnostic rooms must be sanitized prior to use. Other cleaning, sanitizing, laundering, disinfection and general good housekeeping practices must be applied through the hospital (American Society of Heating Refrigerating and Air-Conditioning Engineers 2003).

#### **4.3.2. Air-side Measures**

The most important measure that must be satisfied is the cleanliness of the HVAC system which supplies clean air to the sterile spaces in a hospital. During the operation of the system, zones especially where moisture and matter collected such as drain pans, humidifiers, etc. must be controlled periodically. It must be kept in mind the infection risk can rise due to poor design and maintenance of the HVAC system. The key factor is minimizing the opportunity of collection of dust and moisture in the system. Some of the points that need the maximum care are listed as follows (American Society of Heating Refrigerating and Air-Conditioning Engineers 2003).

- **Outside air intakes** must be located properly. Intake of dust, soil, leaves, trash, moisture etc. with the fresh air must be avoided. Intake louvers must be used to prevent snow or rain to enter the fresh air duct.
- **Cooling coil drain pans** or drainage traps must transfer the condensate water and the accumulation of condensate in pans or traps must be avoided.
- **Humidifiers** in air handling units or duct mounted humidifiers must completely evaporate the water to prevent collection of moisture on other equipments. Equipments where dust is collected, such as filters, must not be located too close to a moisture source like a cooling coil or a humidifier.



- **Easy access** for air handling unit and duct equipments must be provided for inspection and cleaning. It must be always kept in mind that a properly designed system must be accessible and maintainable for continuous clean operating conditions.

For dilution ventilation, proper air distribution profiles must be applied in the sterile spaces. For example, laminar air flow units must be used in operating rooms to create a clean area and to direct the particles to the exhaust grilles. Also the supplied air must be properly filtrated for decreasing the contamination of the supply air and for effective dilution ventilation. This process lowers the concentration of airborne contaminants by exhausting contaminated air and supplying the space with contaminant-free air. This makeup air may consist of totally fresh air or a combination of fresh and recirculated and properly filtrated air, depending on the specific medical application and nature of the contaminants in the space.

Filters rated 90%-95% efficiency (using ASHRAE Dust Spot Test Method) are able to remove 99.9% of all bacteria and similarly sized particles. High efficiency filters must have an efficiency of 99.97% when tested at an aerosol of 0.3 micrometer diameter. These filters are effective in filtering viable viruses as small as 0.01 micron as they are normally attached to much larger particles, in addition to their effectiveness at bacteria and mold filtration (American Society of Heating Refrigerating and Air-Conditioning Engineers 2003).

Directional airflow between the spaces is the control of the flow of air from the clean room to the less clean one. This air flow is achieved by the establishment of a relative differential pressure between the spaces. When there is the need for protecting the room air from contaminants, positive pressure differential is utilized to keep the air flowing from the room to the surrounding spaces. The room is negatively pressurized when the spread of contamination from a space to the adjacent spaces needs to be prevented. The room differential pressure is maintained by a difference on supply-exhaust airflow rate difference and of course the airtightness of the room.

Ultraviolet germicidal irradiation (UVGI) is an increasing technique that is used in HVAC applications. UVGI, having a wavelength of 200 to 270 nanometers, destroys the airborne microorganisms under certain suitable exposure conditions, duration and intensity. The UVGI units have different types like air handling unit, duct mounted, packaged UV-fan recirculation units. Also UVGI arrangements that continuously

irradiate the upper levels of a room are available but lower level (occupied zone) irradiation must be avoided since exposure to UV may be harmful.

The effectiveness of upper level UVGI is being questioned since only a part of the room is irradiated. In addition to this fact, all UVGI equipment needs frequent maintenance since settled dust on the lamp reduces the irradiation and for checking the units for burnedout lamps. Also UVGI is less effective when the relative humidity of the air is higher than 70%. For these reasons UVGI is accepted only as supplemental protection to filtering systems for controlling of the spread of infection.

Relative humidity and also the temperature of the space affect the risk of infection not just like the UVGI but in several different ways. It is indicated that the survival rates of certain species of airborne microorganisms in the indoor environment are greatest in very low or very high ranges of relative humidity. It is proved that the microorganisms are less viable in a middle range of relative humidity. Also moderately humidified environment increases the settling rate of aerosols since in humid environment, it is harder for aerosols to dry and lose mass, reducing the suspension time in air (American Society of Heating Refrigerating and Air-Conditioning Engineers 2003).

A lot more factors that show the importance of HVAC system on infection control practices can be added. The HVAC system is an important element of an overall infection control program. A well designed and maintained HVAC system is an important addition to overall building hygiene but a poorly designed system supports the microbial growth and distributes this contamination through the building.

## CHAPTER 5

### STERILE SPACES IN HOSPITALS

There are many different spaces used for various activities in a hospital. Some of these spaces require higher hygienic needs than the others. DIN 1946-4 classifies these spaces into two groups as Class I and Class II as high or very high need of hygiene and normal levels of hygiene, respectively. The list of most common Class I spaces is given below.

- Operating suites,
- Delivery rooms,
- Intensive care rooms,
- Isolation rooms,
- Central sterile services (Deutsches Institut für Normung 1999 March, American Institute of Architects 2006, American Society of Heating Refrigerating and Air-Conditioning Engineers 2003)

Additional spaces can be classified as Class I during the design of hospital upon the decision of hospital hygienist.

#### 5.1. Operating Suite

An operating suite is a space, complete with its required sub-facilities, that is designed to perform required surgical operations. The components of an operating suite are;

- Operating rooms,
- Pre-operation (pre-op) rooms,
- Anesthesia equipment rooms,
- Post-operation (post-op, recovery) rooms,
- Sterile equipment rooms,
- Soiled equipment rooms,

- Staff support areas,
- Interconnecting corridors and halls (American Society of Heating Refrigerating and Air-Conditioning Engineers 2003).

### 5.1.1. Operating Room

An operating room is the space where the surgical procedures take place and this space requires high levels of hygiene since the infection risk is high. Because of this reason, operating room personnel wear protective garments such as gloves, shoe covers, masks, caps etc. Since operating rooms are one of the most important rooms in operating suite in terms of patient health, a lot more information and standards on ventilation and air conditioning systems for operating rooms can be found in literature compared to the other components of an operating suite.



Figure 5.1. View from operating room  
(Source: West Walley Hospital 2005)

### **5.1.2. Pre-op Room**

Pre-op room is the room where the patients are prepared for surgery. The patient is transferred to operating suite on wheelchair or stretcher and introduced to pre-op room first. In this room, the sedation is applied if it is needed according to the type of surgery, the heart beat and blood pressure of the patient are checked, the procedure that is going to be followed during surgery is reviewed and the patient is readied to be transferred to the operating room.



Figure 5.2. Pre-op room

(Source: East Oregon Surgery Center 2003)

### **5.1.3. Anesthesia Equipment Room**

Anesthesia equipment room is the space where the anesthetic equipments are cleaned, tested and stored. When needed, the required equipments are transferred to the related space to be used.

### **5.1.4. Post-op Room**

Post-op room is similar to pre-op rooms. Patient is transferred to this room from the operating room for post-operative treatment. The patient is held in this room until

the effects of anesthesia are removed and first medications are given. Patient is held under post operative treatment until it is been decided by the nurses that the patient is ready for transferring to intensive care or patient room.



Figure 5.3. Post-op Room

(Source: Cumberland Health Care Foundation 2007)

### **5.1.5. Sterile and Soiled Equipment Rooms**

Sterile equipment room holds the sterile instruments and medical supplies that are used during surgical procedures. The level of hygiene in sterile equipment rooms must be equal or higher than the operating room. These spaces must be positively pressurized with respect to the neighbouring spaces. The direction of airflow must be outwards even it is adjacent to an operating room. By this way it is ensured to minimize the contamination level in the room and the risk of contamination of sterile equipment is reduced.

Used equipments are collected and stored in soiled equipment rooms. Disposable and reusable equipments are separated and reusable equipments are sent for cleaning and sterilization. This room must be kept under negative pressure with respect to the adjacent spaces in order to keep the airborne contaminants in the room.

## **5.2. Delivery Room**

Delivery room is the space where the birth takes place. Two kinds of delivery rooms are found in hospitals as traditional and alternative delivery rooms. In traditional delivery room design, expectant mothers are moved to delivery rooms for delivery following the labour phase. After the delivery, mothers are moved to recovery room and for the final stage, they moved to the post partum unit, where the mother and her baby rest. The alternative delivery room design (Labour/Delivery/Recovery [LDR]) is a specialized type of patient room. In this delivery room design the mother is not moved but all the required functions are supplied in the same room according to the phase of delivery. Some designs of modern delivery rooms may include the post partum phase in which the mother and her baby are treated for the duration of their stay in hospital in the single LDR unit which is called LDRP (Labour/Delivery/Recovery/Post Partum) unit.

These types of delivery rooms are used for normal deliveries. If surgical intervention is required, the mother is moved to cesarean operating rooms (named also as delivery operating rooms). The delivery operating room is almost identical with general operating rooms. Following the cesarean section operation, the mother is moved back to her room for recovery and post partum (American Society of Heating Refrigerating and Air-Conditioning Engineers 2003).

## **5.3. Intensive Care Units**

Intensive care units are spaces where extremely ill patients are continuously monitored and assisted by life-support units in necessary situations. There are special types of intensive care units each serving for different purposes. The most common types of intensive care units are surgical intensive care, medical intensive care, cardiac care, post-anesthesia care, neurological intensive care, burn/wound intensive care and neonatal intensive care. Whether specialized or generalized, the design considerations for the intensive care units are similar, except for the neonatal intensive care units. Newborn nursing operations for infant care are much more focused on the patient's bedside than other types and this reason obligates considering different design conditions.

According to the different aims of intensive care units, the expectations from the HVAC systems may differ. For instance, the burn intensive care units need high level of hygiene while normal intensive care units do not. In addition, higher relative humidity level is required for burn intensive care units, compared to the others (American Society of Heating Refrigerating and Air-Conditioning Engineers 2003).



Figure 5.4. Intensive Care Unit  
(Source: JSP Health Network 2003)

## 5.4. Isolation Rooms

The purpose of an isolation rooms is to protect health care workers, other patients and visitors from exposure to any airborne infectious agents. To control the transfer of microorganisms via air, isolation rooms must be implemented.

Two types of isolation rooms exist; negative pressure room (or airborne infection isolation room) and positive pressure room (or protective environment room) (American Society of Heating Refrigerating and Air-Conditioning Engineers 2003). Both types of rooms aim to control air flow and reduce the number of airborne infectious agents to a level that ensures infection of other person is unlikely.



### **5.4.1. Positive Pressure Rooms**

Patients with suppressed immunity due to some reasons such as surgical operation, drug use and illness are kept in these rooms. The aim is to reduce the risk of transmission of infection from the environmental sources to the susceptible host via air. This room is a specialized patient room that has proven to have outward air flow through all its six surfaces and sustained positive air pressure with respect to all six surfaces, including the outside wall.

High or very high levels of hygiene are required for protective environment rooms. For this purpose, this room has specific ventilation design features such as HEPA filtering and specialized air distribution profile, where the air is supplied near the patient bed and exhausted towards the door of the room (American Society of Heating Refrigerating and Air-Conditioning Engineers 2003). Another key factor for ventilation design is the diluting the contaminants in the room air, and this is provided by adequate fresh air change rates.

### **5.4.2. Negative Pressure Rooms**

Patients are placed in negative pressure rooms to reduce the risk of transmission of infection via air from the patient to the other patients and hospital staff. This kind of room is also known as airborne infection isolation rooms. This room is especially used for airborne infectious patients in order to be kept, examined and treated.

In this patient room, on contrary with the protective environment room, inward air flow through all six surfaces is provided and negative air pressure with respect to all adjacent rooms is maintained.

High level of hygiene is not needed for airborne infection isolation rooms. The recommended practice is to transfer the exhaust air by an independent ductwork system, which is maintained in negative pressure, and to filter the exhaust air by high efficiency air filters before releasing it to outdoor. It is not a necessity for the room to have an electronic pressure monitoring and control system; but a mechanical means of measuring the pressure relationship is required (American Society of Heating Refrigerating and Air-Conditioning Engineers 2003).

## 5.5. Central Sterile Services

Central sterile services department cleans and prepares instruments and equipment for use in surgical procedures, delivery, emergency care and related areas. This department in the hospital is responsible from various duties. These responsibilities can be listed as follows.

- Cleanup of surgical case carts; separation of trash, linens and instruments.
- Decontamination of instruments and washing of carts.
- Cleaning of instruments including ultrasonic cleaning, soaking and processing through a washer/sterilizer.
- Assembly of instrument sets and supplies for surgical packs and packaging.
- Sterilization of packs, labeling and storage.
- Preparation of case carts or sets of packs for scheduled and emergency procedures
- Delivery of case carts or sets of packs to the served departments.
- Receipt and stocking of supplies and linens to be used in packs.
- Inventory control and administration (American Society of Heating Refrigerating and Air-Conditioning Engineers 2003).

Central sterile services department is responsible in some cases for the delivery of sterile equipment to the served departments.

The level of hygiene in sterile equipment storages in central sterile services department must be equal or higher than the operating room. These spaces must be positively pressurized with respect to the neighbouring spaces. The soiled equipment work areas in this department must be kept under negative pressurization.



Figure 5.5. View from central sterile services department sterile storage area  
(Source: WA Country Health Service 2002)

## CHAPTER 6

### HVAC DESIGN PARAMETERS FOR STERILE SPACES

Criteria for HVAC design of sterile rooms involve indoor and outdoor temperature and humidity, room pressure, filtration stages, total and fresh air change rates. In addition, economical factors for maintenance and operation, heating and cooling loads, glazing characteristics etc. must be taken into account. The effects of the mentioned design parameters on thermal comfort and infection control are discussed in this chapter.

#### 6.1. Temperature

Room temperature directly affects the thermal comfort of both hospital staff and patients. Especially, the staff wearing protective garments working under highly radiant lighting can be affected easily in terms of thermal comfort. This uncomfortable feeling affects the concentration; consequently the result of the activity being held in the room can be affected negatively.

The thermal comfort feelings of surgeons working under lighting and in protective garments are different from other operating room personnel. Surgeons generally feel more comfortable at lower temperatures while nurses and anesthesia specialists feel comfortable at higher temperatures. Generally, temperatures between 24-26°C are suitable for the thermal comfort of patient while temperatures below 21°C increase the risk of hypothermia. However, the thermal comfort of surgical staff is greatly reduced with the room temperatures higher than 23°C (Melhado, Hensen and Loomans, Literature Review of Staff Thermal Comfort and Patient “Thermal Risks” in Operating Rooms 2006).

Not only the thermal comfort is taken into account to determine design temperature, but the activity being held in the room must also be considered. Especially in operating rooms, the type of operation must be defined since different types of

operations require different room temperatures. Some examples are (American Society of Heating Refrigerating and Air-Conditioning Engineers 2003);

- 32°C with a low relative humidity level found beneficial for treating certain kinds of arthritis.
- High relative humidity with 32°C is used for burn patients.
- Room temperature around 30°C is used for pediatric surgery.
- For cardiac surgery, room temperature is set about 15-16°C and raised up to temperatures around 25°C
- Room temperature around 15-16°C is used for transplant operations.

Since the room temperature depends on the type of operation, the temperature must be individually controlled for each operating and delivery room (American Institute of Architects 2006).

In spaces where the health of the patients is more important than the thermal comfort, room temperature must be specified in a range in which the growth of the microorganisms are affected and/or the immunity system of the patients are not affected, negatively (American Society of Heating Refrigerating and Air-Conditioning Engineers 2003).

## **6.2. Relative Humidity**

Like the room temperature, the relative humidity ratio is a factor affecting the thermal comfort of both patients and hospital staff. A high level of relative humidity is a common thermal disturbance, especially when combined with low room temperature. Consequently, the concentration of staff may be adversely affected by this disturbance. Humidity control during cooling of the air is very important to prevent this adverse effect.

As in temperature, relative humidity level of the room must not act as a potent risk for the patient's health. Previous studies have shown that average values for relative humidity between 40% and 70% are not suitable for microbial growth. In addition to this fact, low levels of relative humidity results with the drying or the mucous coating on special tissues in the upper and lower respiratory tracts which causes the particles in the air to be breathed deeply into the lungs (American Society of Heating Refrigerating and Air-Conditioning Engineers 2003).

Other effect of relative humidity ratio of room air is on the patient's wounds. Low relative humidity ratio results with excessive drying of the wound, especially in surgeries. High relative humidity ratio is needed during eye surgeries or tissue transplant operations for burn wounds where the drying of the wound is not desired. For example, up to 95% relative humidity is used for burn patients. In some cases, low relative humidity levels may be required, such conditions can be experienced in treatment of arthritis, where the relative humidity level are maintained at around 35% (American Society of Heating Refrigerating and Air-Conditioning Engineers 2003).

### **6.3. Filtration**

A sterile space in a hospital is generally closed environments. The fresh air need of this space is provided by mechanical ventilation system. In order to prevent the increment of particle concentration in a space, the supply air must be filtered appropriately. It is reported that the microorganisms are transported by the particles suspended in the air; therefore, an increase in the particle concentration would result with an increase in the microorganism concentration.

The particles present in the supply air is not the only source of particle concentration. Along with the particles transported into a sterile space by supply air, particles are also generated in space by the activities. These particles may also carry microorganisms.

The microorganisms that are present in the air may be bacteria, viruses or originate from molds. The bacteria which are highly infectious and transported via air or air-water mixture are Mycobacterium tuberculosis and Legionella pneumophila (Legionnaire's disease). Varicella (chicken pox/shingles), Rubella (German measles), and Rubeola (regular measles) are the examples of viral infections that are transported by air. It is proved that some molds like Aspergillus can be fatal to advanced leukemia, bone marrow transplant and other seriously immunosuppressed patients.

Previous studies have shown that 99.9% of all bacteria present in a hospital are removed by 90-95% efficient filters. The main reason of this is that the bacteria exist in colony-forming units that are larger than 1 mm. The use of high efficiency particulate air (HEPA) filters having filtering efficiencies of 99.97% in certain areas is recommended. It is proved that many of the airborne viruses are in sub-micron size,

thus, there is no exact method to eliminate 100% of the viable viruses from air even HEPA and/or ultra low penetration (ULPA) filters offers the greatest efficiency. Implementing ultraviolet (UV) lights or chemicals to inactivate the viable viruses are not proven effective (American Society of Heating Refrigerating and Air-Conditioning Engineers 2003).

#### 6.4. Air Velocity and Air Distribution

The velocity of air in a sterile space is important due to its influence on the comfort feeling along with the other effects such as drying of the wounds, especially in surgical site.

There are two types of air distribution profiles for a sterile space which are laminar and turbulent flow. The velocity of air is a significant factor for air distribution.

Turbulent air distribution is generally used in older operating rooms and in other sterile spaces in an operating suite such as post-operation or sterile equipment rooms. The particles that are present in the operating room are considered to be distributed homogeneously for this kind of air distribution profile (Figure 6.1). Conventionally ventilated operating rooms are generally used for general surgeries which do not require high level of hygiene. It is recommended to use laminar flow operation rooms for surgeries requiring high level of hygiene (American Society of Heating Refrigerating and Air-Conditioning Engineers 2003).

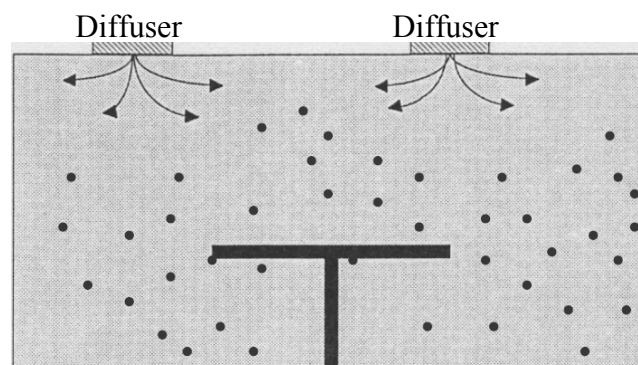

Figure 6.1. Turbulent air flow distribution

In laminar flow rooms, a clean space is created in the room and the flow profile prevents the contaminant from entering this clean space from outside. In this kind of room, the filtered air with low particle concentration is supplied above the patient and/or the personnel, and the air flows down to floor level and is exhausted by low level registers (Figure 6.2). Since the velocity of the air is low, the supply air temperature must always be 1-2°K lower than the room temperature in order to provide the flow of the air down to floor. Supplying cold air above the personnel may reduce the thermal comfort. Also it is shown that if the operating room staff lacks in required precautions for infection control, the air moving from the staff to the patient transfers skin squames and particles from the head of the staff (Owers, James and Bannister 2004). Horizontal laminar flow rooms are recommended to overcome these problems of vertical laminar flows but it is almost impossible to protect the horizontal laminar flow of the air because of the medical equipments, movement of staff etc (Melhado, Hensen and Loomans, Review of Ventilation Systems in Operating Rooms in View of Infection Control 2006).

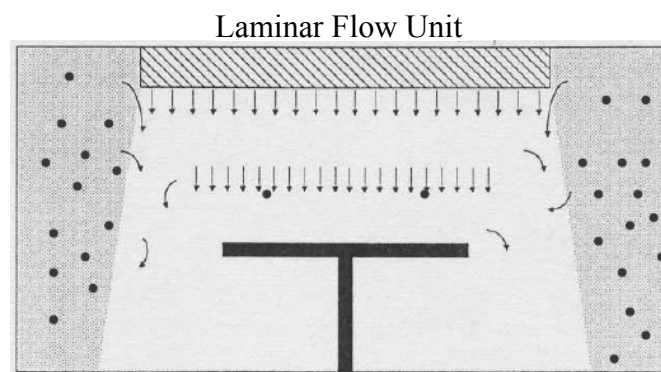

Figure 6.2. Laminar air flow distribution

For completing the sweep by the air supplied by the laminar flow unit, only supplying colder air is not enough. Most of the time, air distribution profile is not complete without proper exhaust grille arrangements. To complete the distribution profile, it is recommended to arrange low level exhaust grilles. Another example for complete air distribution is the recommended profile for airborne infection isolation and protective environment rooms. It is recommended to supply the filtered air in the region near the door of the room and exhaust in the region near patient bed for airborne infection isolation room and supply the air from above the patient bed and exhaust from



the region near the door (American Society of Heating Refrigerating and Air-Conditioning Engineers 2003). Using low level exhaust is beneficial in operating rooms because of the precipitation of waste anesthetic gases. It is more effective by low level exhaust to remove these waste gases (Melhado, et al. 2005).

## **6.5. Pressurization**

The aim of the pressurization is to protect the cleanliness of room air from the contaminants that may enter from the neighbouring spaces. Since most of the airborne viruses are in sub-micron size, filtration is not a perfect method to effectively eliminate the viable particles. Therefore, the best practice to prevent airborne viable particles to spread is achieved by pressurization.

The air can flow from a space to the neighbouring spaces through the openings of the room. The pressure difference between these spaces is the main factor to specify the flow between them. Positive pressurization means an outwards flow from the room while negative pressurization refers to an inwards flow. The flow direction of air between the spaces must be determined by comparing the cleanliness levels of neighbouring rooms. Air must flow from a space with high level of hygienic need to a lower one. This required air flow can be maintained by the openings of the room like door perimeters. Furthermore, the transfer grilles with preset spring loaded dampers can be employed to maintain required pressure difference. Thus, the excess of supply or exhaust air can flow from/to the space and the rooms are maintained under a constant pressure even the doors are kept closed for a long period.

In literature, there are two methods to maintain required air flow, thus the pressurization. These are discussed under relevant headings. It is not important how the pressure relation between the spaces is maintained, the designed airflow between the room must be provided 24-hours a day. The ventilation system serving to these rooms must be operated all day long. For conservation of energy, the systems can be operated at reduced air flow rates when the rooms are not used.

### **6.5.1. Volumetric Flow Rate**

The pressure difference between the room and the adjacent spaces is maintained by providing differentials in volumetric flow rates of supplied and extracted air. For example, supply air flow rate of 150 m<sup>3</sup>/h and exhaust flow rate of 100 m<sup>3</sup>/h would result with the positive pressurization of the room while the inverse flow rates would result with negative pressurization. The disadvantage of this method is when the doors of the room are kept close for a long period; the pressure of the room would become too high/low which would make high amount of air flow between the rooms at high velocities when the doors are opened. When the doors are closed, a noise may be generated due to high velocity of air flow through door perimeter.

### **6.5.2. Room Differential Pressure**

Volumetric flow rate method can be used for most hospital rooms. Room differential pressure method is generally used for high-risk areas (American Society of Heating Refrigerating and Air-Conditioning Engineers 2003). This method involves maintaining the pressure difference between the sealed room and its neighbours steady. The required pressure difference which will be kept constant is determined by the standards and guidelines. The pressure of the room and its neighbours is monitored continuously.

## **6.6. Total and Fresh Air Changes**

Total and fresh air change rates are important to maintain the required air quality of the spaces. The supply of fresh air improves the air quality in terms of increasing the oxygen amount and diluting the chemical gases and particles that exist in the room air.

The mechanically supplied air can be 100% fresh air or the fresh air can be mixed with filtrated return air. The decision about supplying 100% fresh air or mixture of fresh and returned air depends on various factors such as the activity being held in the room, required hygiene level, energy conservation, operation costs etc.

## CHAPTER 7

### COMPARISON OF STANDARDS ON STERILE SPACES

Standards and guidelines on HVAC design of sterile environments in hospitals have been developed by institutions and organizations around the world. Each country develops its own standard and despite well known effects of HVAC systems on infection, no union standard exists. Some of these standards and guidelines are investigated for this study. The standards and guidelines investigated in this study are;

- German standard for heating, ventilation and air conditioning systems of hospitals, DIN 1946-4 (Deutsches Institut für Normung 1999 March)
- ASHRAE's HVAC Design Manual for Hospitals and Clinics (American Society of Heating Refrigerating and Air-Conditioning Engineers 2003)
- AIA's Guidelines for Design and Construction of Health Care Facilities book which approaches to hospital design in terms of architectural, mechanical and electrical engineering points of views (American Institute of Architects 2006)
- Guidelines of CDC (Melhado, et al. 2005)
- Brazilian standard for air quality of hospital spaces, NBR 7256 (Melhado, et al. 2005)
- Spanish ventilation standard, UNE100713:2003 (Melhado, et al. 2005)
- Design guidelines for hospitals that belongs to the Netherlands, CBZ (Melhado, et al. 2005)
- Guidelines of HICPAC (Melhado, et al. 2005)
- French ventilation standard, NF S90:351 (Melhado, et al. 2005 and Dorchies 2005)
- German guidelines for hospital ventilation and air conditioning, VDI 2167 (Verein Deutscher Ingenieure 2004 December)
- Australian Queensland Government Private Hospital Guidelines (PHG) (Health Department of Western Australia Facilities & Assets Branch 1999)

- Queensland Government Infection Control Guidelines (ICG) (Queensland Health Communicable Diseases Unit & Capital Works Branch 2002)

The full texts of DIN 1946-4, HVAC Design Manual for Hospitals and Clinics, Guidelines for Design and Construction of Health Care Facilities, VDI 2167, Private Hospital Guidelines and Infection Control Guidelines have been found, however, information about the rest of the references is evaluated from the reported studies in literature.

In this chapter, the comparison of the design parameters is performed via tables. The discussion is performed for each sterile space of hospital.

## **7.1. Operating Suite**

The operating suite is the special department of the hospital for surgical procedures. The operating suite consists of several different components which are;

- Operating rooms
- Pre-op rooms
- Anesthesia equipment storage
- Post-op rooms
- Sterilization rooms
- Clean and dirty storage areas
- And interconnecting corridors and halls.

The most important component of the operating suite is the operating room. The most detailed information about the design parameters can be found for operating rooms in reviewed references. In addition to recommendations for operating room, information on the design parameters of pre-op and post-op rooms was found. No information was found for the rest of the sub-components of operating suite. Detailed investigations of the recommended values for these spaces are discussed below.

### **7.1.1. Operating Room**

In the reviewed references, the operating rooms are classified into groups according to their hygiene need and the types of surgical procedures that are executed in the room. As can be seen from the Table 7.1 most of the references classify the

operating rooms according to the type of the surgical procedure. ASHRAE and AIA divide the operating rooms into three groups as Class A, B and C. Class A operating room serves for minor operations that are performed under local, topical or regional anesthesia without preoperative sedation. Intravenous, spinal and epidural operations are excluded and these methods are appropriate for Class B and C rooms. Class B room provides minor or major surgical procedures performed in conjunction with oral, parenteral or intravenous sedation or under analgesic or dissociative drugs. Class C rooms are suitable for major surgical procedures that require general anesthesia or regional block anesthesia and support of vital bodily functions (American Institute of Architects 2006 and American Society of Heating Refrigerating and Air-Conditioning Engineers 2003). In opposition to this classification, DIN 1946-4 groups operating rooms under two classes according to the hygiene need of the rooms. Class I holds the rooms that need high or very high levels of hygiene and Class II is for normal levels of hygiene. Class I is divided into two, again with respect to the hygienic needs and thus, the air distribution profile. Rooms with very high hygiene need and laminar air flow unit forms Class Ia and rooms with relatively lower need for hygiene forms Class Ib. Class Ib rooms are permitted to have turbulent air flow profiles (Deutsches Institut für Normung 1999 March). Brazilian standard NBR specifies the operating rooms as general purpose and cesarean operating rooms (Melhado, et al. 2005) while Australian Private Hospital Guidelines specifies as for general purpose and orthopedic procedures (Health Department of Western Australia Facilities & Assets Branch 1999). The classification of Australian Infection Control Guidelines is similar to the classification of DIN 1946-4 where Option 1 is the equivalent of Class Ia and Option 2 is the equivalent of Class Ib (Queensland Health Communicable Diseases Unit & Capital Works Branch 2002).

A temperature range between 18 and 24°C is recommended by most of the publications but PHG recommends a lower temperature as 16°C. As can be seen from NBR, the recommended temperature for delivery is higher than other surgical procedures.

Generally a wide range of relative humidity is recommended as from 30% to 60%, however, ICG proposes a narrower range as 50-55%. For filtration, most of the standards specify the filtration stages and filter types that must be used for removing the particles. For example DIN 1946-4 forces designers to clean the supply air by at least three stages of filtration as F5, F7 and H13 types of filters according to DIN EN 779

and DIN EN 1822. PHG requires HEPA filter installations with adequate pre-filtration and the HEPA filters must have a minimum of 99% hot DOP arrestance efficiency. The pre-filtering must be completed by extended surface filters of minimum 80% arrestance efficiency to No.4 dust and 95% to No.2 Dust as specified in related Australian Standard AS1132 Methods of Test for Air Filters for Use in Air Conditioning and General Ventilation. In opposition to this definite description of filtration, AIA lacks the information about filtration.

Laminar flow air supply profile is recommended by all references, especially where very high levels of hygiene is needed. In addition to this, DIN 1946-4 and ICG permit the use of turbulent systems for Class Ib (or Option 2) operating rooms. The air velocity parameter depends greatly on the air distribution profile and the velocity of air is an important factor. Generally low velocities for air are preferred in operating rooms to prevent the settled dust to become airborne again. Also the disturbance created by the airflow must be minimized. Because of these reasons the range of air velocity in an operating room is specified around 0.20 m/s. For the supply velocity ASHRAE recommends a range of 0.25-0.45 m/s while VDI 2167 recommends 0.20 m/s (Verein Deutscher Ingenieure 2004 December). The velocity limit is set as 0.3 m/s for CDC. (Melhado, et al. 2005) The velocity values are defines in a range of 0.1-0.25 m/s for PHG at the operating room table and 0.2 m/s for ICG as VDI.

All of the investigated references agree about the pressurization of the operating room and a positive pressurization of the room is recommended. Since the operating room is one of the cleanest spaces in an operating suite, only permitted airflow is from sterile equipment stores to operating rooms. The air must flow from the operating room to other adjacent spaces. The method for providing this positive pressure in an operating room is the other issue that is handled by the standards. ASHRAE and AIA give a constant pressure difference value between the operating room and neighbouring spaces. In addition to this, ASHRAE and ICG define both the pressure difference and a difference of flow rates between the supply and the exhaust air. This is useful when an active control of the pressure difference between the rooms is not wanted. The designer can easily be informed about how to create sufficient pressure difference. While these abovementioned references give constant values for maintaining required pressure difference, DIN 1946-4 follows a different path. The recommended practice in DIN 1946-4 is supplying the room with additional 20 m<sup>3</sup>/h air for every meter joint length of

Table 7.1. Recommended values for HVAC design parameters for operating rooms

Reference	Operation of Room Type	Temp.	Relative Humidity	Filtration	Air Velocity	Air Distribution	Pressure	Pressure Difference	Outdoor ACH	Total ACH
<b>ASHRAE</b>	Class A	18-26 °C	30-60%	MERV 7/8-14/15-17	0,25-0,45 m/s	Laminar	P	2,5-7,5 Pa / 35-47 L/s excess supply	5*/15** / 15(lt/sn)/ person	25* / 15**
	Class B			MERV 7/8-14/15-17						
	Class C			MERV 7/8-14/15-17						
<b>AIA</b>	Class A	20-23 °C	30-60%	N/D	N/D	Laminar	P	2,5 Pa	3	15
	Class B									
	Class C									
<b>DIN</b>	Class Ia	19-26 °C	30-60%	F5-F7-H13	N/D	Laminar / Turbulent	P	20 m³/m excess supply	1200 m³/h	2400 m³/h
	Class Ib			F5-F7-H13						
<b>CBZ</b>	N/A	18-24 °C	N/A	F5-F7-F9-H13	N/A	Laminar	P	N/A	N/A	N/A
<b>VDI</b>	N/A	18-24 °C	30-50%	F5/F6/F7-F9-H13	0,20 m/s	Laminar	P	N/D	N/D	N/D
<b>NBR</b>	General	19-24 °C	45-60%	G2-F2-A3	N/A	N/A	P	N/A	N/A	N/A
	Cesarean	22-26 °C		N/A						

Table 7.1. (Cont.) Recommended values for HVAC design parameters for operating rooms

Reference	Operation of Room Type	Temp.	Relative Humidity	Filtration	Air Velocity	Air Distribution	Pressure	Pressure Difference	Outdoor ACH	Total ACH
<b>CDC</b>	N/A	N/A	30-60%	%30-%90-%99,97	0,3-0,5 m/s	N/A	P	N/A	3 / %20	15
<b>NF S90</b>	N/A	N/A	40-60%	F6-F7-H13	N/A	Laminar	P	N/A	N/A	N/A
<b>UNE 100713</b>	N/A	N/A	N/A	F6-F9-H13/H14	N/A	Laminar	P	N/A	N/A	N/A
<b>PHG</b>	General	16-24 °C	40-70%	See Text	N/D	Laminar	P	N/D	30%	20
	Orthopaedic			See Text	0,1-0,25m/s				6	55
<b>ICG</b>	Option 1	18-24 °C	50-55%	Two Stage (AHU & Terminal)	0,2 m/s	Laminar	P	15 Pa / 150-200 lt less exhaust	350 l/s or 8	1700l/s - 2000 l/s if orthopaedic
	Option 2	18-24 °C	50-55%	Two Stage (AHU & Terminal)	0,2 m/s	Laminar / Turbulent	P	15 Pa / 150-200 lt less exhaust	350 l/s or 8	20

\* Recommended outdoor and total ACH values for return air systems

\*\* Recommended total ACH for 100% fresh air systems

42 N/A - Not Available  
N/D - Not Defined



the room. This joint length is the subtraction of the length of the hinged side of the doors and operable windows from the total perimeter.

The required fresh and total air flow rates are specified in the investigated references. DIN 1946-4 advises 1200 m<sup>3</sup>/h flow rate for fresh air and 2400 m<sup>3</sup>/h for the total supply air flow rate as minimum rates. The recommendation of ICG for total air supply rate is defined as 1700 l/s (6120 m<sup>3</sup>/h) for general surgery and 2000 l/s (7200 m<sup>3</sup>/h) for orthopedic surgeries. When compared to the rest of the recommended values, except for the recommendation of PHG for orthopedic surgeries, which is 55 air changes per hour (ACH).

The rest of the references define the required air flow rates in terms of air changes per hour, which depends on the volume of the operating room, meaning how many times the room air is changed in an hour. General suggestion is 3 ACH for fresh air and 15 ACH for total air supply. This means that the room air must be changed 15 times in an hour, and 3 of this 15 change must be fresh air. As an example; if the flow rates are calculated for a 6m x 6m room with a 3.5m clear height, meaning a room having a volume of 126 m<sup>3</sup>, the room must be supplied with at least 1890 m<sup>3</sup>/hr air, and at least 378 m<sup>3</sup>/hr of this 1890 m<sup>3</sup>/hr must be fresh outdoor air. An important point to emphasize is the note given for defined fresh air rate by ASHRAE, which is the minimum amount of fresh air must not be lower than 15 l/s per person occupying the room. Another point is that this reference suggests two different values for ventilation rates, according to the system used. It is recommended to change the air of the room for 25 times when return air systems are used while 15 ACH is suggested for 100% fresh air systems. Also, one can see from the air change rates suggested by the references, most of the investigated publications permit the use of return air.

As seen from Table 7.1, there is no criterion about the limit of the particle contaminations in an operating room. However, the levels for microbiological contamination are reported in some studies in literature. Chow and Yang specified a criterion as 35 cfu/m<sup>3</sup> for an operating room at rest and they stated that the microbiological count should not exceed 180 cfu/m<sup>3</sup> in operation state for United Kingdom. In the same study, it is declared that in an ultra clean operating room with laminar flow unit, the microbiological count limit is set as <10 cfu/m<sup>3</sup> within the region 30 cm of the wound for conventional clothing. Furthermore, this level should be <1 cfu/m<sup>3</sup> when total body gowns are implemented. The maximum accepted level under these conditions is defined as 10 cfu/m<sup>3</sup>. For the rest of the operating room outside the

clean area, the maximum allowed limit is set as 20 cfu/m<sup>3</sup> (Dharan and Pittet 2002 and Chow and Yang 2005). The same limit is set as 25 cfu/m<sup>3</sup> for the hospitals in Geneva, Switzerland and 5 cfu/m<sup>3</sup> in the French Guidelines (Landrin, Bissery and Kac 2005). In the study of Balaras the level of the particles in an operating room is limited according to ISO 14644-1 which is a standard named as “Cleanrooms and associated controlled environments Part 1: Classification of air cleanliness”. It is mentioned that the cleanliness class of an operating room should not be greater than Class 7 (Balaras, Dascalaki and Gaglia 2007). In the study of Dharan and Pittet, it is declared that few countries have set bacterial threshold limits for conventionally ventilated operating rooms, although most recommend 20 ACH to obtain 50-150 cfu/m<sup>3</sup> of air. In their study, a table related to the classification of operating theatre zones according to their risk categories is given and the limits of airborne particles and bacterial concentrations in the University of Geneva Hospitals in Switzerland are presented (Dharan and Pittet 2002).

### **7.1.2. Pre-op and Post-op Rooms**

As mentioned above, an operating suite consists of several components and one of the most important components is the operating room. The most detailed information about the design of HVAC systems for operating rooms can be found in literature and investigated references. Additional information on some of the design parameters for pre and post-op rooms were found during the investigation of the listed publications. This information is given in Table 7.2

The recommended ambient temperature for these spaces is 21 - 24°C by ASHRAE and AIA. DIN 1946-4 suggests an ambient temperature of 22 - 26°C. For the relative humidity ratio of the room air, a range of 30-60% is suggested by ASHRAE and DIN 1946-4. Turbulent air flow is strongly suggested by ASHRAE but no other comment about the air distribution within the room is found in the rest of the references. DIN 1946-4 and ASHRAE’s design manual both agree on the pressurization issue of these spaces. In both references, positive pressurization of pre and post operation rooms is suggested. It can be added that airflow from the sterile equipment store rooms and

Table 7.2. Recommended HVAC design parameters for pre- and post-operative rooms

Reference	Temp.	Relative Humidity	Filtration	Air Velocity	Air Distribution	Pressure	Pressure Difference	Outdoor ACH	Total ACH
<b>ASHRAE</b>	21-24 °C	%30-60	Same with OR	N/D	Turbulent	P	N/D	2	6
<b>AIA</b>	21-24 °C	%30-60	N/D	N/D	N/D	N/D	N/D	2	6
<b>DIN</b>	22-26 °C	N/D	F5-F7-H13	N/D	N/D	N/D	N/D	30 m <sup>3</sup> /m <sup>2</sup> .h	N/D
<b>PHG</b>	N/D	N/D	See Text	N/D	N/D	N/D	N/D	(20 l/s)/person or 2	10

Table 7.3. Suggested HVAC Design parameter values for delivery operating rooms

Reference	Temp.	Relative Humidity	Filtration	Air Velocity	Air Distribution	Pressure	Pressure Difference	Outdoor ACH	Total ACH
<b>ASHRAE</b>	20-24 °C	30-60%	N/D	N/D	N/D	P	N/D	5*/15**	25*/15**
<b>AIA</b>	20-23 °C	30-60%	N/D	N/D	N/D	P	N/D	3	15
<b>DIN</b>	min 24 °C	N/D	F5-F7-H13	N/D	N/D	N/D	N/D	15 m <sup>3</sup> /m <sup>2</sup> .h	N/D
<b>PHG</b>	N/D	N/D	See Text	N/D	N/D	N/D	N/D	20 (l/s)/person or 2	10
<b>NBR</b>	22-26 °C	45-60%	N/A	N/A	N/A	P	N/A	N/A	N/A

\* Recommended outdoor and total ACH values for return air systems

N/A – Not Available

45 \*\* Recommended total ACH for 100% fresh air systems

N/D - Not Defined

operating rooms can be permitted. ASHRAE and AIA guidelines both recommend the same air changes for fresh and total air supplies while DIN standard suggests a certain amount of fresh air per unit area of the room and Australian PHG suggests supplying fresh air according to the number of people occupying the room.

Only AIA guideline lacks the information about filtration. ASHRAE and DIN standards suggest filtration stages same as operating rooms. PHG recommends filtering supply the air for post-op rooms with filters having minimum dust arrestance efficiencies of 80% for dust No.4 and 95% to dust No.2. When invasive procedures take place, this filtering system must be used as a pre-filter for HEPA filtering.

## **7.2. Delivery Room**

Only brief information about temperature, relative humidity, air changes and pressurization in delivery rooms are given in some of the reviewed standards and guidelines, no clear statement about the hygiene level of delivery rooms is found. DIN 1946-4 is the only standard in which the hygienic condition of delivery rooms is specified. According to DIN standard, the delivery rooms are defined as Class II spaces; however the hygiene need for the delivery operating rooms is stated as Class I. Not only German standard DIN 1946-4 declares that the delivery rooms are Class II spaces, but the Australian Private Hospital Guidelines also specifies the delivery rooms as spaces where relative low levels of hygiene is needed than the operating rooms unless invasive procedures takes place. Under these circumstances, delivery room is classified as having need of high hygiene and HEPA filtering is applied using the previously defined pre-filter set.

The recommended values for the HVAC design parameters of the delivery rooms are given in Table 7.3. The comparison of Table 7.1 and 7.3 reveals that higher room temperatures are required for delivery rooms. It is declared in reviewed references that the dilution ventilation is an important factor in ventilation of the delivery rooms. The waste anesthetic gases must be properly removed from the room air. For providing successful dilution of chemicals and particles in the air the rate of fresh air change and air distribution becomes important.

### **7.3. Intensive Care Unit**

There are different types of intensive care units all serving to different purposes. The expectations from the HVAC system may differ according to the different aims of the intensive care units. For instance, according to ASHRAE, burn intensive care units need high level of hygiene while normal intensive care units do not (American Society of Heating Refrigerating and Air-Conditioning Engineers 2003).

In studied standards and guidelines, there is no clear information about the hygiene level of the intensive care units, except the German standard DIN 1946-4 in which intensive care units are divided into two types as intensive care units for regular patients and the units for patients having high infection risk. Table 6.4 shows the available data in literature relating to HVAC design parameters of intensive care units. As seen from the table, ASHRAE and DIN standards are only references that provide the most specific information for special intensive care units.

As in the Table 7.4, higher room temperatures are suggested for newborn intensive care units, when compared to the other types. Generally 30-60% or relative humidity ratio is suggested to be maintained in the units. In addition, higher relative humidity ratios are needed in burn intensive care units to prevent the excessive drying of the tissues (American Society of Heating Refrigerating and Air-Conditioning Engineers 2003). Another point that needs to be emphasized is the requirement that is suggested by ASHRAE's design manual is that, according to this reference, laminar air flow must be maintained in burn intensive care units.

### **7.4. Positive Pressure Room**

The implementation aim of these rooms is to protect the immunosuppressed patients from the environmental infectious sources. High or very high levels of hygiene are required for protective environment rooms. Recommended conditions to be fulfilled are given in Table 7.5.

The investigated references that suggest values for both fresh and total supply air rates accept using return air systems. On the contrary, Australian Infection Control Guidelines obliges the design of 100% fresh air systems. All references recommend filtration of air by implementing H13 class HEPA filters. For the air distribution in the

Table 7.4. Recommended minimum design values for HVAC systems of intensive care units

Reference	Room Type	Temp.	Relative Humidity	Filtration	Air Velocity	Air Distribution	Press.	Press. Diff.	Outdoor ACH	Total ACH
ASHRAE	General	21-24 °C	30-60%	N/D	N/D	N/D	N/D	N/D	2	6
	Newborn	22-26 °C	30-60%	N/D	<0,25m/s@isolet level	N/D	N/D	N/D	2	6
AIA	Burn	N/D	40-60%	HEPA	0,25m/s@bed level	Laminar	P	N/D	2	6
	General	21-24 °C	30-60%	N/D	N/D	N/D	N/D	N/D	2	6
DIN	Newborn	22-26 °C	30-60%	N/D	N/D	N/D	N/D	N/D	2	6
	Infectious	24-26 °C	N/D	F5-F7-H13	N/D	N/D	P	N/D	30 m <sup>3</sup> /m <sup>2</sup> .h	N/D
VDI	General	N/D	N/D	F9	N/D	N/D	P	N/D	100 m <sup>3</sup> /h.person	N/D

N/D - Not Defined

Table 7.5. Recommended design parameters of HVAC systems for isolation rooms

Reference	Temp.	RH	Filtration	Air Velocity	Air Distribution	Press.	Pressure Difference	Outdoor ACH	Total ACH
<b>ASHRAE</b>	21-24 °C	N/D	MERV 8-17	<0,5m/s throw	Laminar	P	2,5 Pa	2	12
<b>AIA</b>	24 °C	N/D	N/D	N/D	N/D	P	2,5 Pa	2	12
<b>DIN</b>	24-26 °C	N/D	F5-F7-H13	N/D	N/D	P	N/D	30 m <sup>3</sup> /m <sup>2</sup> .h	N/D
<b>VDI</b>	N/D	N/D	H13 filter on supply	N/D	N/D	P	N/D	100 m <sup>3</sup> /h.person	N/D
<b>PHG</b>	N/D	N/D	%99 DOP efficiency	N/D	N/D	P	N/D	2	12 or 9 l/s/m <sup>2</sup>
<b>ICG</b>	N/D	N/D	H13 filter on supply	N/D	N/D	P	%10 less exhaust	12 or 145 l/s.patient	N/D

N/D - Not Defined

room, only ASHRAE recommends supplying of air above the patient bed by laminar flow units and low level exhaust near the door of the room.

## **7.5. Central Sterile Services Department**

The level of hygiene in sterilization area and sterile equipment stores in central sterile services department is equal of higher than the operating room. In opposition to this assumption, German standard DIN 1946-4 accepts sterile equipment stores in operation suites as Class I spaces but any sterilization or sterile equipment store area outside the operating suite is declared as Class II. In accordance with DIN 1946-4, PHG declares that the central sterile services department or the sterile equipment supply unit in the operating theatre that are not attached to an operating room, do not need hygiene levels as the operating rooms need. If the sterile equipment area is attached to an operating room, high efficiency particulate air filtering is required with adequate pre-filters.

The recommended HVAC design parameters by studied standards and guidelines for both soiled and sterilized equipment areas are shown in Table 7.6. Not all of the studied references have commented on the filtration stages for supply air except VDI, DIN and ASHRAE standards. Although there is not a concrete comment about the filtration stages in most of the references, the same level of filtration that is used for the operating rooms can be implemented since the same level of hygiene is needed. For the case of the differential pressure of the room, all reviewed references agree on the positive pressurization of sterilized equipment areas. The soiled equipment room should be maintained under negative pressure.

The suggested ambient temperatures of the sterilized or soiled equipment areas vary between 20 and 25°C and the minimum room temperature for soiled equipment areas is recommended by AIA guidelines, which is defined as 20°C. It can also be seen from Table 7.6 that the recirculation of return air is permitted in sterile equipment areas.



Table 7.6. Recommended HVAC design parameters for central sterile services and sterile equipment stores

Reference	Room Type	Temp.	Relative Humidity	Filtration	Air Velocity	Air Distribution	Press.	Pressure Diff	Outdoor ACH	Total ACH
<b>ASHRAE</b>	Soiled Eqpt Room	22-25 °C	30-60%	N/D	N/D	N/D	N	N/D	2	6
	Sterile Eqpt Room			MERV 8 - 15			P		2	4
	Sterile Work Room			MERV 8 - 15			P		2	4
<b>AIA</b>	Soiled Eqpt Room	20-23 °C	N/D	N/D	N/D	N/D	N	N/D	N/D	6
	Sterile Eqpt Room	24 °C	30-60%				P			4
	Sterile Work Room	N/D	max. 70%				P			4
<b>DIN</b>	Sterile Eqpt Room	22-26 °C	N/D	F5-F7-H13	N/D	N/D	P	N/D	15 m <sup>3</sup> /m <sup>2</sup> .h	N/D
<b>PHG</b>	N/D	N/D	N/D	See Text	N/D	N/D	P	N/D	N/D	10
<b>VDI</b>	N/D	N/D	N/D	F7-F9-H10/H11	N/D	N/D	P	N/D	N/D	N/D

N/D - Not Defined

## CHAPTER 8

# HVAC SYSTEM AND EQUIPMENT FOR STERILE SPACES IN HOSPITALS

In the reviewed guidelines and references, the design parameters for HVAC systems serving to sterile areas of hospitals are defined. Generally, no detailed information is given about the equipment and system design. In this chapter, brief information about the equipments and systems serving to sterile spaces in hospitals are discussed. The equipment used in the HVAC system of sterile areas should fit the sterile rules and the system should provide the desired ranges for the design parameters.

### 8.1. Equipment

Equipments used for the HVAC system of the sterile spaces of the hospitals are high in numbers when compared to those of the comfort application. The design of this kind of systems is complicated and required specific technical knowledge. In this section, information about the equipment is given.

#### 8.1.1. Air Handling Unit

An air handling unit (AHU) is the main component of an HVAC system. It supplies air to the sterile spaces, filtrates the supplied air to remove the particles and microorganisms, regulates the room temperature and humidity ratio.

Practically, air handling units used for sterile applications are called as hygienic air handling units. Figure 8.1 shows a typical hygienic air handling unit. Hygienic AHUs have some additional features when compared with the AHUs used for the comfort applications. These additional features are summarized below:

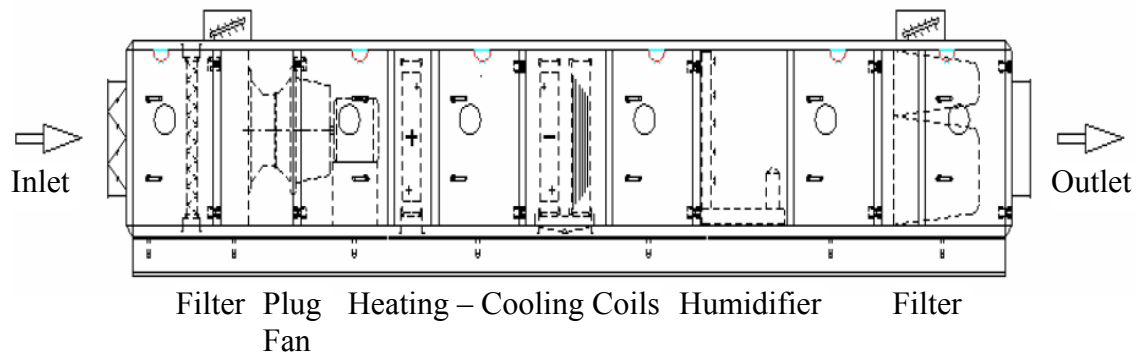

(a)

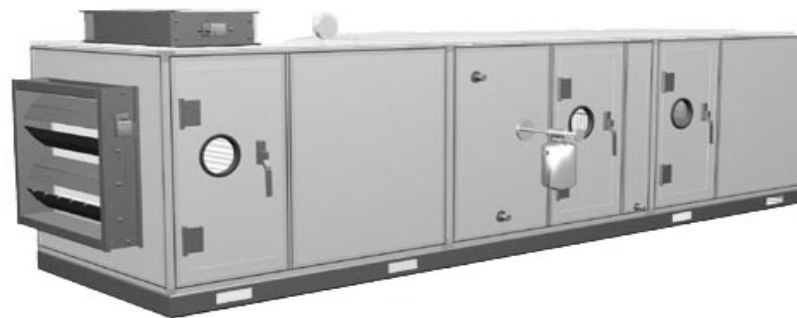

(b)

Figure 8.1. Schematic (a) and photographic (b) views of a hygienic air handling unit (Sources: (a) ANIL, Mobedi and Özerdem 2007, (b) Suzhou Industrial Park Jiatai Dust-Free Equipment Co. Ltd. 2008)

- The casing of the hygienic AHUs must be leakproof. The processed air should not leak from the casing and the unprocessed outdoor air must not enter into the air handling unit.
- The AHU must not allow the accumulation of particles and contaminants on any part of the AHU components. The inner surfaces of the AHU must be smooth and have low roughness as possible. The components with porous structures must not be used in the construction of the hygienic AHU.
- The AHU must not also permit the accumulation and infestation of microorganisms. The unused water or high humidity levels inside the AHU must be avoided in order to prevent the infestation of microorganisms. All the material used in the construction of the AHU must have antibacterial feature.

- The inner components of the AHUs must be easily accessible and cleanable. Moreover, it must not be affected by the used chemicals and disinfectants for surface cleaning.

Air handling units can be divided into two groups as conventional and packaged air handling units. A conventional air handling unit is assisted with chiller or boiler for cooling and heating purposes, however a packaged air handling unit contains a heat pump used for heating and cooling of the air passing the unit.

### **8.1.1.1. Conventional Air Handling Units**

A conventional air handling unit is composed of filter, cooling coil, heating coil, heat recovery unit, humidifier, fan etc. Some important components of the conventional air handling units are described in follows.

#### **8.1.1.1.1. Air Filters**

The removal of contaminant in the air is achieved by the air filters. Generally G4 and F7 class filters are found at the inlet of an AHU while F9 class filters are considered at the outlet. It should be mentioned that there is HEPA filters at the duct outlet of the sterile spaces.

#### **8.1.1.1.2. Coils**

Coils are used for heating or cooling of air. They are connected to chiller or boiler according to the required process. The coils of an AHU must be easily accessible or removable for cleaning purposes. For cleaning of the fins, the distance between the fins of the coil must be sufficiently large (Kenter 2007). The drop eliminator located beyond the cooling coil must separate the condensed water droplets effectively before flowing further through the AHU. Moreover, the condensed water hold by the eliminator must not be accumulated in the drain pan. It must be removed from the drain pan immediately. To achieve this, the double slope drain pans made of stainless steel or other non-corrosive and antibacterial materials must be implemented.

### **8.1.1.1.3. Humidifier**

Three types of humidifier are used in practice. The first one is air washers which are generally used for industrial applications. The second type is evaporated type humidifier which is more favorable for comfort applications compared to the air washer humidifiers. The third type of humidifiers is steam humidifier. Since water is a favorable environment for the growth of the bacteria and microorganism, the use of the steam humidifier is advised for sterile environments. However, some standards and guidelines permit the use of evaporated humidifiers under certain conditions.

### **8.1.1.1.4. Fan and Motor**

The base and the fan itself must be easily cleanable. Generally the use of plug fans is advised. The safety class of electric motor must permit the cleaning of the motor.

### **8.1.1.1.5. Sound Attenuator**

The material of the sound attenuator must not break off easily and contaminate the air. In addition, the material must not permit the accumulation of dust and infestation of microorganisms.

### **8.1.1.1.6. Air Handling Unit Casing**

The abovementioned equipment must be mounted into a cassette which must have additional features over the AHUs of conventional comfort applications. The most important additional features can be listed as, smoothness of the surfaces, prevention of the dust accumulation, strong tightness and cleanability. Also air-tight shut-off dampers must be used at the inlet and outlet of the AHUs.

### **8.1.1.2. Packaged Air Handling Units**

Packaged AHUs (Figure 8.2) are used for conditioning of the air supplied to the indoor, removing the contaminants of the air, and supplying the fresh air. This kind of

AHUs conditions the temperature of the air by an integrated heat pump. Also the removal of contaminants is achieved by the compact filters. Due to advantages of the packaged air handling units, they become attractive for application on HVAC of the sterile spaces in recent years. The main drawback of this kind of system is limited operation temperature. The packaged AHU must be able to work at high and low outdoor temperatures. The packaged AHUs must have the same hygienic features as the conventional air handling units possess.



Figure 8.2. Packaged air handling unit  
(Source: ANIL, Mobedi and Özerdem 2007)

### **8.1.2. VAV Box**

VAV stands for the first letters of variable air volume. These boxes are used for the regulation of the supplied air to the spaces. As shown in Figure 8.3 a VAV box consists of an electronic card, a regulation damper, flowmeter and damper motor. Based on the signals received by VAV box, it increases or decreases the rate of air flows. Electronic card compares the set value with the measured flow from the flowmeter and actuates the motor.

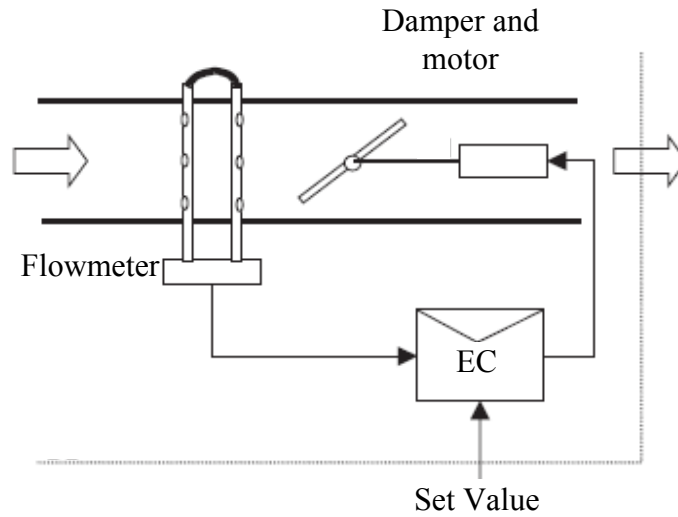

(a)

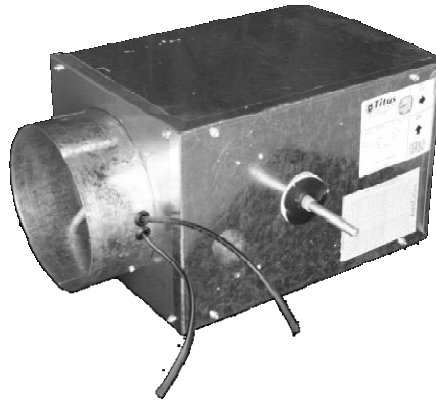

(b)

Figure 8.3. Schematic (a) and photographic (b) views of a VAV box  
 (Sources: (a) Halton Group 2008, (b) Mechanical Products Intermountain 2008)

VAV boxes are used for two purposes. One of them is to provide constant air volume when the pressure drop of the terminal filters increase, consequently lowering amount of air flows through the filters. By this way, the amount of air that is sent to air filter can be increased; therefore the same amount of air can pass through the filter. The other purpose is to provide low amount of air when the sterile room is not in use, for conservation of energy. By this way, the air flow can be lowered providing the pressure difference relation between the spaces is maintained.

### 8.1.3. CAV Box

CAV stands for the first letters of constant air volume. The VAV boxes can be used for providing constant flow of air, but since the CAV boxes operate mechanically and do not require any electrical power, they are preferred. A CAV box supplies constant flow of air. The pressure differences between the neighbouring spaces can be easily achieved by using CAV boxes. Schematic and photographic views of a CAV box is shown in Figure 8.4. It consists of lapels, a spring mechanism and a manual set-up mechanism. A CAV box supplies constant air flow rate regardless of the pressure changes on the upstream side of the box.

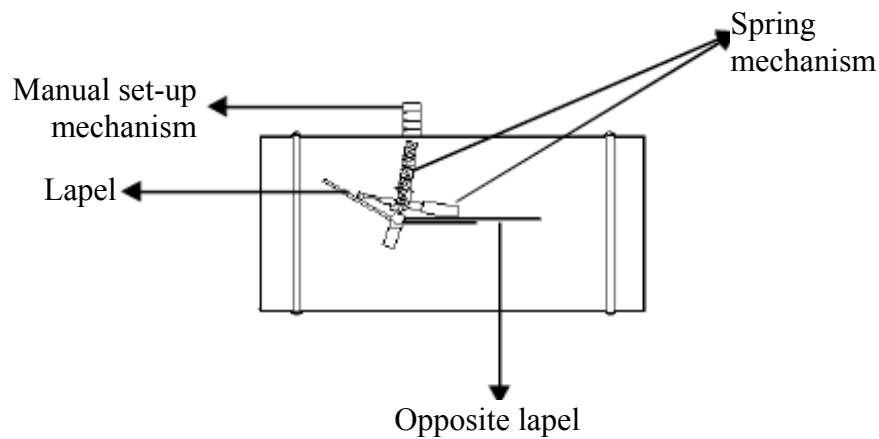

(a)

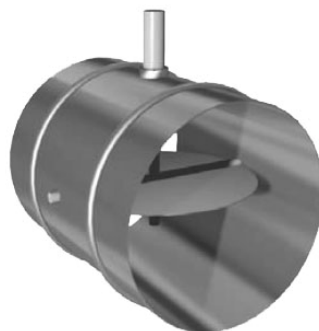

(b)

Figure 8.4. Schematic (a) and photographic (b) views of a CAV box  
(Source: (a) ANIL, Mobedi and Özerdem 2007, (b) Halton Group 2008)



### **8.1.4. Duct Type Electrical Heater**

Duct type electrical heaters are used in the operating rooms and other sterile spaces. During surgery, a rapid change of the room temperature may be demanded. The time response of the electrical heaters is high and they can increase the supply temperature rapidly. Moreover, by implementing the electrical heaters, the rooms of sterile area can be maintained at different levels.

### **8.1.5. HEPA Filter**

The words “HEPA filter” stands for high efficiency particulate air filter. The HEPA filter (Figure 8.5) is generally used in the terminal unit and located in the sterile space. Since HEPA filters are easily damaged, a great care must be given during the installation of HEPA filters. HEPA filters must fit into filter housings tightly to prevent any air leakage.

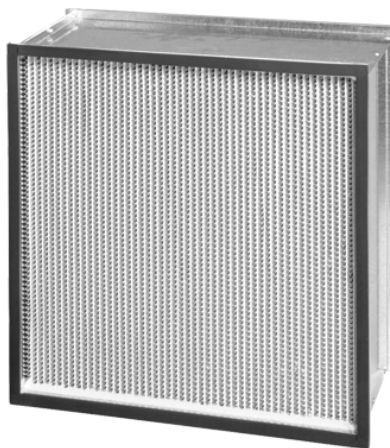

Figure 8.5. HEPA filter  
(Source: AAF International 2008)

### **8.1.6. HEPA Filter Box**

A HEPA filter is located in a HEPA filter box which consists of ductwork connection, plenum, seals, tightening mechanism and diffuser. Since the HEPA filter

box is a terminal unit and it is located in the sterile space, it must be made of hygienic materials.

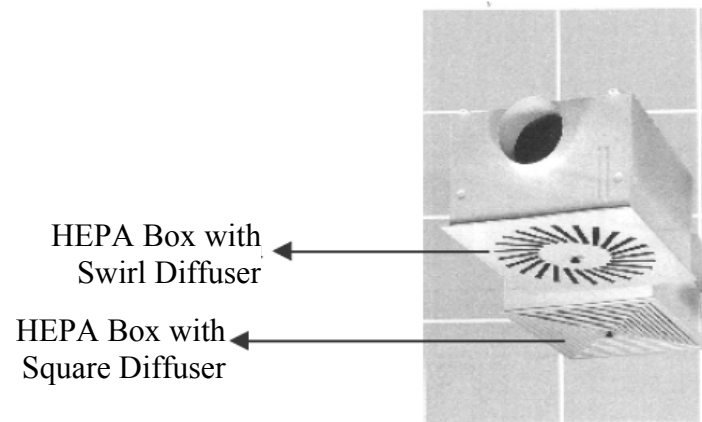

Figure 8.6. Swirl and square diffusers and HEPA filter boxes

(Source: ANIL, Mobedi and Özerdem 2007)

The diffuser may be square or swirl. The types of these diffusers are shown in Figure 8.6. The type of the selected diffuser depends on the geometrical parameters of space. The turbulent flow is achieved when a HEPA filter box is used. It is assumed that the contamination in the air is homogeneous when the clean air is supplied by the HEPA filter boxes.

### 8.1.7. Laminar Flow Unit

The aim of laminar flow unit is to remove the particles from a critical area by the horizontal or vertical displacement of the air. The transfer and propagation of particles in laminar flow is lower than turbulent flow. Generally, a vertical laminar air flow is used in operating rooms to provide an air curtain between the room personnel and the patient. A laminar air flow must cover the patient, surgery team and the sterile instruments used during surgery (Kenter 2007).

A laminar flow unit consists of ductwork connection, HEPA filter and filter housings, plenum box and laminizator. Similar to the HEPA filter boxes, a laminar air flow unit must be made of proper materials since it is a terminal unit. It is in the sterile space and directly supplies clean air to the space.

The new trend in the operating room ventilation is to protect both the patient, surgery team and the sterile instruments used during the operation. Therefore, the area under the laminar flow unit is enlarged. Moreover, the operations such as total hip replacement or other types of orthopedic surgeries require high sterile conditions. In order to attain the required hygiene level, high ventilation rates are implemented. In order to increase air flow rate in the operating room, laminar air flow units with recirculation air have been developed. This kind of laminar flow units contains additional fans and filters with minimum class F7. The return air extracted from the room flows through filter mounted in the unit and it is mixed with the fresh air supplied by the air handling unit. A laminar flow unit assisted with recirculation air is shown in Figure 8.7 schematically.

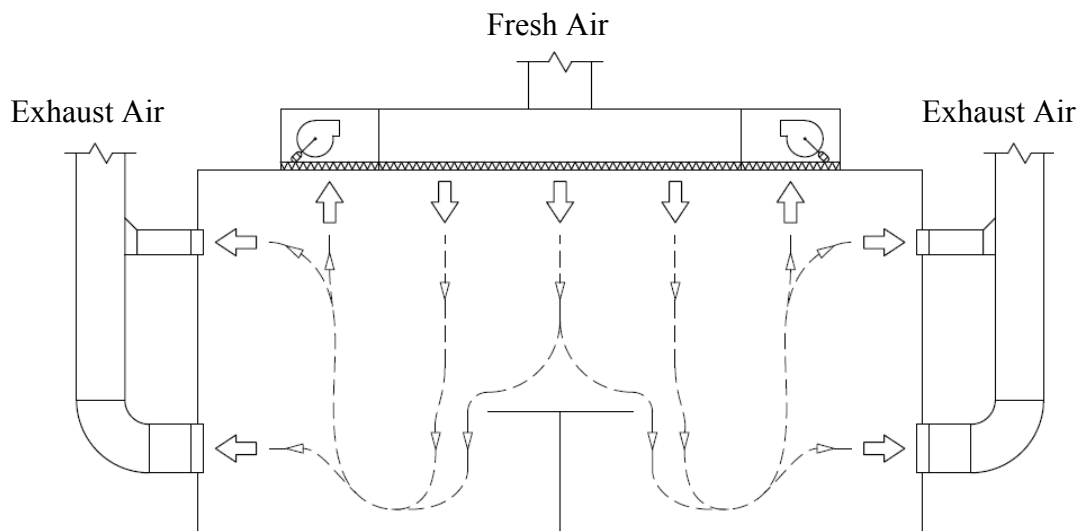

Figure 8.7. Schematic view of a laminar air flow unit with recirculation air

### 8.1.8. Lint Grilles

Lint grilles (Figure 8.8) are used at the exhaust registers of the operating room. The aim of their use is to prevent the clogging of the exhaust ductwork system with lint that originates from the gowns and other fabric used during operating. A lint grille is a cleanable stainless steel mesh filter.

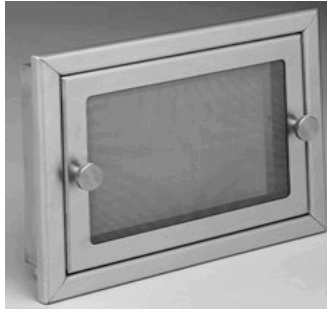

Figure 8.8. Lint grille

(Source: ANIL, Mobedi and Özerdem 2007)

## 8.2. Types of HVAC Systems Serving to Sterile Areas

Different HVAC systems have been developed to provide the required conditions of the sterile spaces. Basically, the HVAC systems serving to the sterile spaces can be grouped into two, which are One-to-One and Multiple Space Systems.

### 8.2.1. One-to-One Systems

In this kind of system, an air handling unit or a packaged air handling unit serves to only one sterile space. A schematic view of one-to-one systems is shown in Figure 8.9. The advantages of one-to-one systems are listed as follows;

- The design of the system is easier,
- There is no need for ductwork equipments such as VAV or CAV boxes. The regulation of the air can be performed by AHU.
- The system can be controlled by simple automation systems or automatic control equipments
- The pressurization of the room can be maintained more sensitively.
- The levels of relative humidity and room temperatures of different operating rooms can be controlled independently.

The only disadvantage of this system is the need for a large area for mechanical equipment.

As seen from Figure 8.9, the airside of One-to-One System consists of the air handling unit, ductwork, shut-off dampers, laminar air flow unit or HEPA filter box, exhaust registers with lint screens and the exhaust fan. The pressurization of the

operating room is provided by frequency converters (shown as FC in the figure) connected to supply and exhaust fans. The temperature of the operating room is controlled by the heating and cooling coils and the humidity level of the room is controlled by the humidifier in the air handling unit. A duct type steam humidifier can be installed in case of hygienic packaged air handling units without humidifier. If a rapid change in the temperature of the room is required, a duct type electrical heater can be implemented.

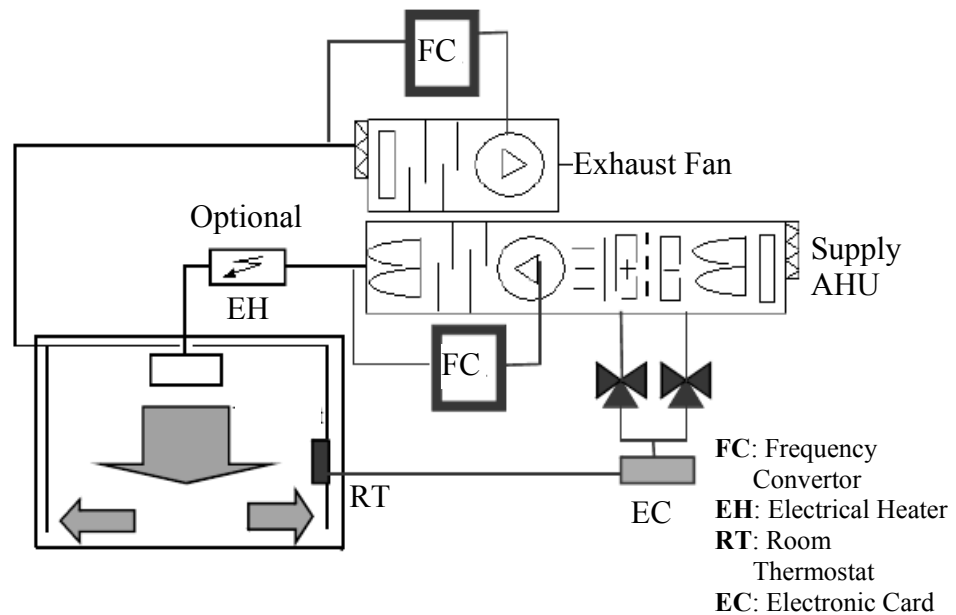

Figure 8.9. Schematic view of a one-to-one system

(Source: ANIL, Mobedi and Özerdem 2007)

### 8.2.2. Multiple Space Systems

As seen from Figure 8.10, an air handling unit or a packaged air handling unit serves to multiple operating rooms or sterile areas. The disadvantages of this system are given below.

- The design of the system is more complicated.
- Many types of ductwork equipment is required.
- Problems on the pressurization between neighbouring spaces may occur.
- It requires complex control systems.
- Different temperature and humidity levels in different spaces need additional duct equipments.

The main advantage of this system over One-to-One Systems is that the Multiple Space Systems occupy smaller area.

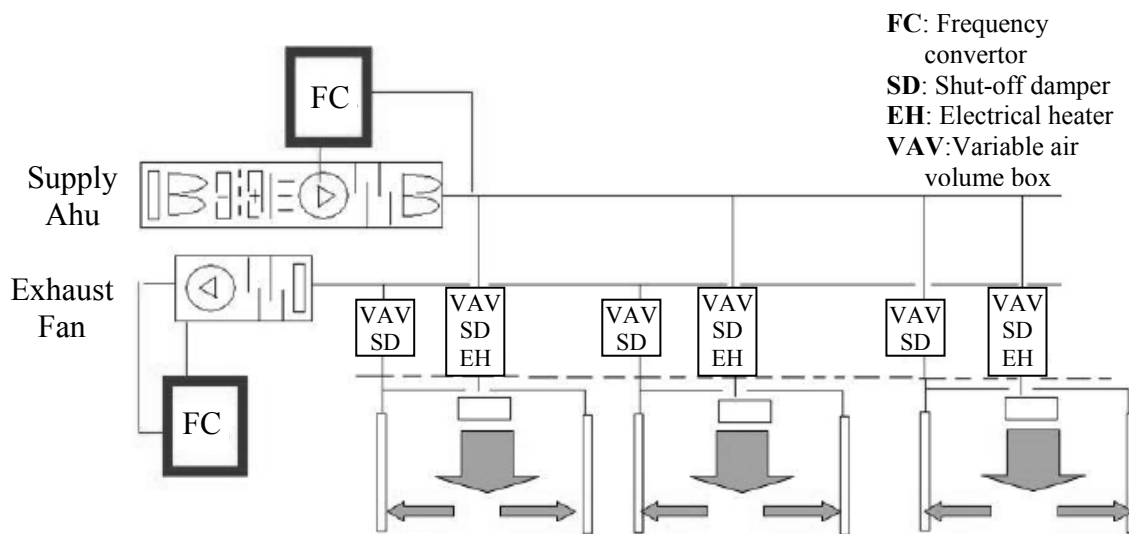

Figure 8.10. A schematic view of a multiple system  
(Source: ANIL, Mobedi and Özerdem 2007)

As seen from Figure 8.10, the Multiple Space System contains air handling unit or packaged air handling unit, VAV boxes for the regulation the airflow rates to the spaces and providing the desired air flow between spaces, electrical heaters (shown as EH in the figure) for providing different room temperatures, shut-off dampers (shown as SD in the figure), laminar flow unit or HEPA filter boxes, exhaust registers with lint grilles and exhaust fan. VAV boxes provide pressure differences between the rooms. The shut-off dampers provide air tightness feature for an operating room when the room is off for maintenance.

Any variation of air flow rate during the operation does not affect the AHU fans since the speed of the fans are also adjusted by the frequency convertors. If the packaged air handling units are used in a Multiple Space System, the supply of variable air flow must be guaranteed.

### 8.3. HVAC Systems for Service Rooms in an Operating Suite

As mentioned in the previous chapters, there are different spaces in an operating suite. The most common spaces faced in an operating suite can be listed as; pre-operation and post-operation rooms, clean and soiled equipment stores, rest areas, etc.

The air flow between these spaces is important for avoiding the cross-contamination. The required air flow directions are specified in the standards and these directions must be maintained. The direction of air flow between neighbouring spaces may be changed due to variation of the air flow rates. The changes in the air flow resistance of filters may reduce air flow rates to the sterile spaces. In order to avoid from air flow variations, CAV boxes and shut-off dampers are used at the supply and exhaust ducts of a sterile room. The CAV boxes supply a constant rate of air flow at the inlet and outlet regardless of the pressure variations in the ducts. Duct type electrical heater is optional. This equipment can be installed if different space temperatures are required.

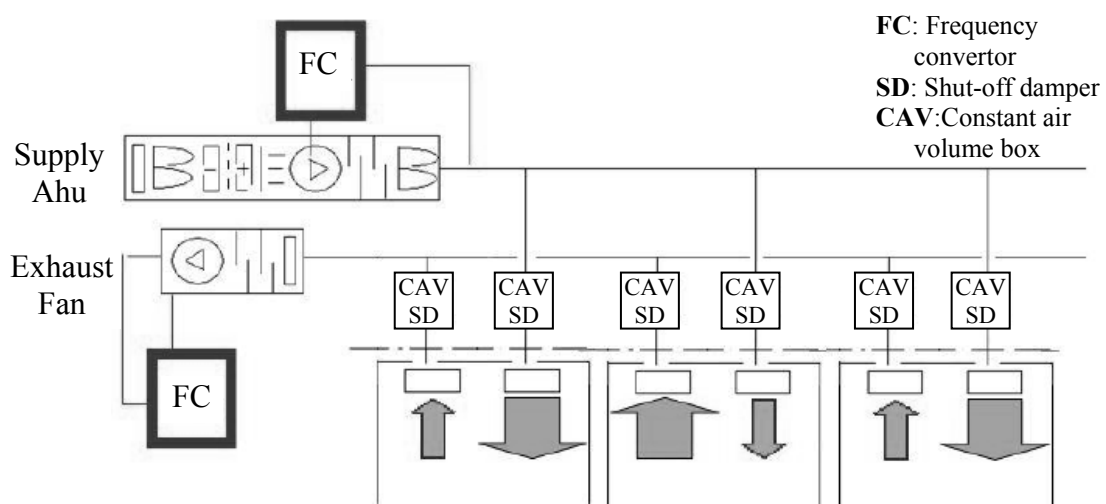

Figure 8.11. A schematic view of the HVAC system for sterile spaces in an operating suite (Source: ANIL, Mobedi and Özerdem 2007)

A schematical view of the HVAC system serving to sterile areas in an operating suite is shown in Figure 8.11. As seen from the figure, the airside of the system consists of air handling unit, shut-off damper, CAV, duct type electrical heaters as optional equipment, HEPA filter box, exhaust registers and exhaust fan. The required flow rate of the air is adjusted by the frequency convertors on the fans (shown as FC in the figure).

## **CHAPTER 9**

### **AN EXPERIMENTAL STUDY ON DESIGN PARAMETERS OF AN OPERATING ROOM**

There are lots of different areas in a hospital that differ in purpose of use. The expectations from the HVAC system serving to these areas are different according to the function of the space. The HVAC systems must be designed by considering the need of the spaces and the activities being held. Especially, the design of HVAC systems of sterile spaces is important since it requires detailed knowledge and expertise when compared to the other spaces of the hospital. In addition to the parameters which should be provided for comfort condition (temperature, humidity ratio and fresh air rate), other parameters such as particle and microorganism concentration, room pressure, air velocity and distribution etc. should also be considered.

After the design stage of the HVAC systems for sterile spaces, the installation of the systems must be completed with great care. The instructions for installation of HVAC systems of sterile spaces should be followed during installation stage. After the installation of the systems, the cleaning of the equipment and primary tests of the system must be completed in order to make the system ready for use. Before the final acceptance of the installed system, validation and final tests should be performed to be sure about the proper functioning of the system.

#### **9.1. Acceptance Tests and Validation of a System**

Validation is a documented systematic approach that ensures continuous and repetitive operation of any facility, laboratory, computer, process or service. Validation of an HVAC system consists of all stages from design to acceptance of a system. Validation of a system can be performed by the control of the following four stages.



**Design qualification** is the certification given after the design stage to prove that the system would satisfy the required quality, legal regulations and specified requirements declared.

**Installation qualification** is the certification given to system successfully completed the design qualification. It is given to prove that the system has been installed in accordance with the related specifications or adapted to the existing system as specified.

**Operation qualification** is the certification prepared for the system successfully completed the installation qualification, and proves that the system is functioning as required in the related specifications.

**Performance qualification** is the certification proving that the system is continuously functioning as required in the related specifications. After the approval for performance qualification, the system must be periodically controlled for continuity of the proper functioning (Özcan 2007).

Tests for installation, operation and performance qualifications of a system can be performed under three different situations. These are named as;

- As-built,
- At rest,
- In operation.

These test conditions are briefly explained in next sections.

### **9.1.1. As Built**

All construction works, including electrical and mechanical, must be completed. The infrastructure for all the services and functions must be completed but the required equipment must not be installed. The tests are performed without any occupant. The aim of the as-built stage tests is to discover any possible infrastructure problems.

### **9.1.2. At Rest**

The tests in “at rest” stage are completed after installation of all equipment in the room. Before performing “at rest” tests, the system should be ready for use. These tests

are completed without any occupants like the as-built stage tests. Most of the detailed technical tests related to the system are performed in this stage.

### **9.1.3. In Operation**

“In operation” tests are performed during the operation of the room. The required equipment and system must be working and occupants must be present in the room. The results of the “at rest” and “in operation” tests may be different.

## **9.2. Purpose of the Present Experimental Study**

As mentioned above, a series of tests and validation must be performed on the HVAC systems for hygienic applications in order to ensure that the designed and installed system is functioning as desired. The system must satisfy the design conditions both in “at rest” and “in operation” conditions. “In operation” tests and validations are important since the system satisfy “at rest” requirements; however, during the operation of the room the same conditions may be deviated.

As a part of this study, an experimental attempt has been performed to demonstrate the differences between the results of the “at rest” and “in operation” tests of an operating room. The operating room temperature, room relative humidity ratio, air velocity and particle concentration were measured continuously throughout a week. Hygienic tests in “at rest” condition have been performed by an independent validation company and the system had been certified according to DIN 1946-4.

These measurements were conducted in an operating room and a sterile corridor of the operating suite in a hospital. The supply air temperature and relative humidity ratio data were measured and saved by the automation system.



Figure 9.1. General view from the operating room

The HVAC systems serving to the considered operating room were an all-air system with completely fresh air. The air flow rate to the operating room was measured as  $8000 \text{ m}^3/\text{h}$ . The HVAC systems were operating at full capacity during night and day. The operating room area was  $6\text{m} \times 6\text{m}$  with a clear height of  $3\text{m}$  (Figure 9.1). The air was supplied by a  $3\text{m} \times 3\text{m}$  laminar flow unit above the operating room (Figure 9.2). The exhaust registers were located on the corners of the operating room as high and low level exhausts. The equipment used for these measurements and the procedure are explained below in a detailed manner.



Figure 9.2. Laminar air flow unit installed in the room

### **9.3. Equipments Used for the Experiments**

#### **9.3.1. Particle Counter**

The CI-450t particle counter (Figure 9.3) is a laser diode based aerosol particle counting device that monitors particles in four size ranges which are 0.3, 0.5, 1 and 5  $\mu\text{m}$ . The device can operate on battery or AC power. The model has a sampling flow rate of 50 liters per minute. The installed battery can supply the device for 2.5 – 3.5 hours of continuous sampling. The sampled air is filtered prior to being exhausted into the room air.

Counts may be displayed and printed via the integrated thermal printer in variety of formats including total count, differential count, concentration per cubic foot and concentration per cubic meter.

As mentioned, up to 3000 sample data can be stored in the internal memory and can be transferred as a comma delimited ASCII file through RS-232 serial port. All samples are date and time stamped.

The device can be programmed to start sampling after an initial delay which gives the operator extra time to clear the area before the particle counter begins

sampling. Other sample setting programs the device to take a certain number of samples then stop, or to take samples once every given time period.

The CI-450t has a user authentication and password protection feature that can be enabled. Up to 20 users may be defined with one to four access levels. A supervisor level is provided for administering users.

The particle sensor used in the CI-450t operates on the light scattering principle. It uses a 50 mW laser diode as the light source and an elliptical mirror focused onto a solid-state photo detector, which converts the light energy into electrical current (Climet Instruments 2005).



Figure 9.3. Climet CI-450t particle counter  
(Source: Climet Instruments Company 2007)

### 9.3.2. Data Logger

INNOVA 1221 data logger (Figure 9.4) can operate as a stand alone data logger or online together with a computer, where the data can be displayed and processed. The data logger also supplies the necessary power to transducers connected to the modules and it controls the measurement. The power supply comes either from a battery pack or a mains power supply. Depending on the configuration the battery pack enables up to 18 hours of measurement to be made.

Parameters are set up on the INNOVA 1221 via the RS-232 interface; transducers are connected to the sockets and it is decided what measurement data will

be stored or retrieved. The instantaneous, mean, maximum, minimum values and standard deviations are measured.

Measurement interval of as low as one tenth of a second can be specified in the INNOVA 7701 application software depending on the transducers chosen. Average time can be specified to determine how long a period the maximum, minimum, mean values and standard deviations are to be calculated.

The 1221 data logger can be disconnected from the computer after the setup has been defined, allowing the data logger to operate as a stand-alone unit. All the measurement data from the transducers is transferred to the data logger and stored in the internal memory, which has a capacity of holding one week's measurement data for 10 minute measurement interval is defined. If real-time measurement data is desired, the computer-data logger connection must remain. The RS-232 interface enables real-time measurement data to be transferred to the computer. The measurement data is stored in the SQL2005 Server database and can be imported to Microsoft Excel using the provided Excel software (LumaSense Technologies A/S 2005).

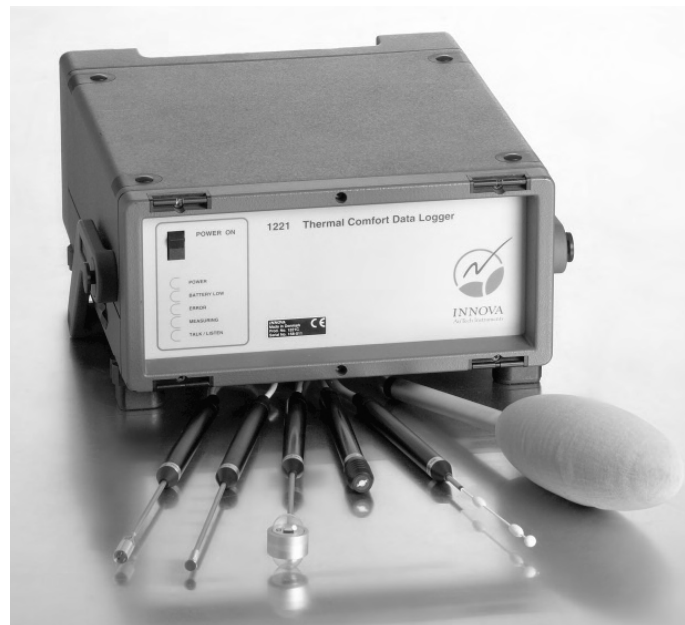

Figure 9.4. INNOVA 1221 data logger and certain transducers  
(Source: LumaSense Technologies A/S 2005)

### 9.3.3. Air Temperature Transducer

The MM0034 air temperature transducer (Figure 9.5) measures the air temperature with minimal thermal radiation interference from hot or cold objects. The measurement principle provides accurate measurement results, which are both stable and traceable.

In order to provide stable and accurate results, a Pt100 resistor sensor is used in this transducer. Pt100 sensor is a resistor sensor having a resistance of  $100\Omega$  at  $0^{\circ}\text{C}$ . The resistor is made of platinum to provide required stability and accuracy.

The sensor is surrounded by an open ended aluminum-foil cylinder. This is highly polished to reduce the thermal radiation interference from any hot or cold bodies in close proximity to the transducer. The cylinder, with its open ends, enables free flow of air to come in contact with the sensor.

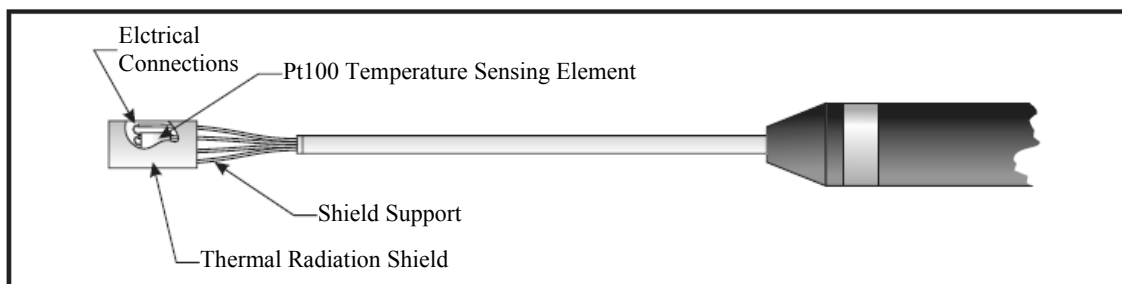

Figure 9.5. MM0034 air temperature transducer  
(Source: LumaSense Technologies A/S 2005)

The sensor can provide measurements in a range of  $5$  to  $40^{\circ}\text{C}$  with  $0.2^{\circ}\text{C}$  accuracy and  $-20$  to  $50^{\circ}\text{C}$  with an accuracy of  $0.5^{\circ}\text{C}$  (LumaSense Technologies A/S 2005).

### 9.3.4. Humidity Transducer

The MM0037 humidity transducer (Figure 9.6) measures the absolute humidity of air. If the relative humidity is wanted to be expressed, the humidity transducers must be connected with air temperature transducer and the relative humidity can be automatically calculated as an index measurement.

The transducer comprises a light emitting diode (LED), a light sensitive transistor, a mirror, a cooling element and a Pt100 temperature sensor. The cooling element is attached to the conical mirror. When the humidity measurements are started, the cooling element is activated and the temperature of the mirror begins to drop. The LED emits a constant beam of light which is reflected by the conical mirror. Under normal circumstances, the light sensitive transistor does not receive any of the light being emitted, however, as the temperature of the mirror drops, condensation forms on its surface. The light being reflected by the mirror becomes scattered and is detected by the light sensitive transistor. This transistor takes control of the temperature of the mirror so that there is a constant film of dew on the mirror's surface. The Pt100 sensor registers this dew-point temperature. This Pt100 resistor sensor is the same with the one used for the air temperature transducer and it has a resistance of 100Ω at 0°C (LumaSense Technologies A/S 2005).

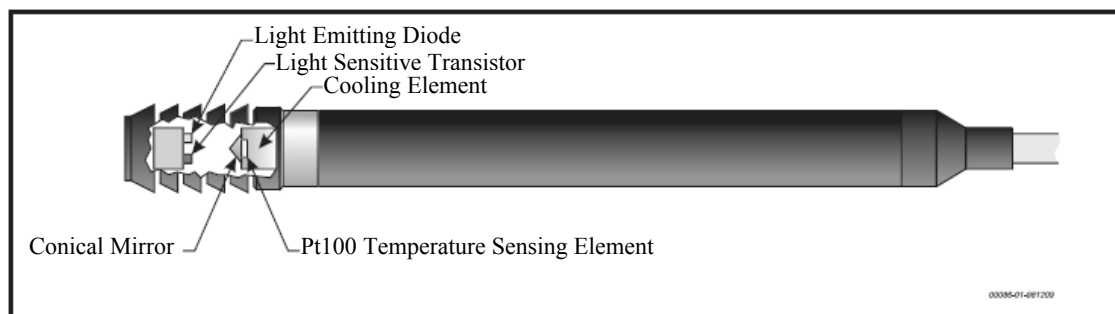

Figure 9.6. MM0037 humidity transducer  
(Source: LumaSense Technologies A/S 2005)

### 9.3.5. Air Velocity Transducer

The air velocity transducer MM0038 (Figure 9.7) is based on the constant temperature difference anemometer principle. The transducer is design to measure indoor air flow velocities therefore the transducer's measurement range concentrates on the lower velocities. The measurement range of the transducer is 0 to 10 m/s. Because of the nature of the air flow in indoor climates, the transducer measures omnidirectional air velocities.

Air velocity is measured as a function of heat loss from a heated body, by measuring the power input required to maintain a constant temperature between two



sensor elements. Heat loss is also a function of the temperature and direction of air flow and the radiative heat exchange with the surroundings. The errors associated with these effects are eliminated through the design and construction of the transducer.

Two sensor elements, one of which is heated electrically, are housed in two plastic foam ellipsoids on a single shaft. The heated sensor contains three heated coils. Temperature and heat loss is measured on the middle coil. This provides better frequency response.

The eccentricity of the ellipsoids and the length of the heating coils are optimized to give the minimum possible variation in directional sensitivity. The controlled electrical heating maintains a constant temperature difference of 15°C between the sensors. The small sphere at the end of the shaft prevents errors occurring if the air flow is parallel to the shaft (LumaSense Technologies A/S 2005)

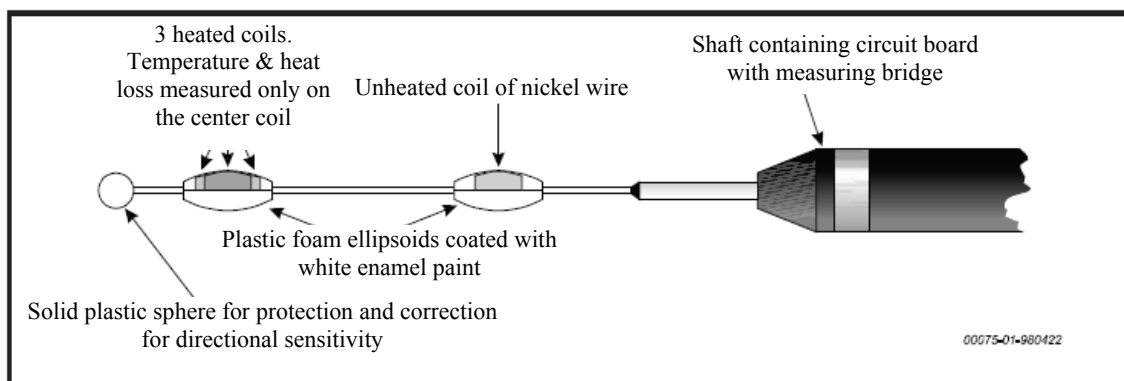

Figure 9.7. MM0038 air velocity transducer  
(Source: LumaSense Technologies A/S 2005)

#### 9.4. Procedure of the Performed Experiments

As it was mentioned in Section 9.2, the aim of the experimental study was to demonstrate the differences between the “at rest” and “in operation” tests for an operating room. Furthermore, the results of the experimental study reveal the transient behavior of HVAC design parameters in an operating room. For this purpose, a thermal comfort data logger INNOVA 1221 and a particle counter CI-450t were used and measurements were completed. A schematic view of the operating room showing location of the devices is shown in Figure 9.8 and the location of the operating room and the sterile corridor is shown in Figure 9.10 which shows a schematic view of the

operating suite. Also a schematic view of the HVAC system serving to the operating room is shown in Figure 9.9. As seen, the air handling unit was serving to the operating room and laminar flow unit was used to provide uniform airflow above the operation table. The extracted air was exhausted directly to outdoors and no mixing between the supply and return air existed. All devices which were used for measuring the temperature, relative humidity, air velocity and particle concentration can be seen in Figure 9.11 and 9.12.

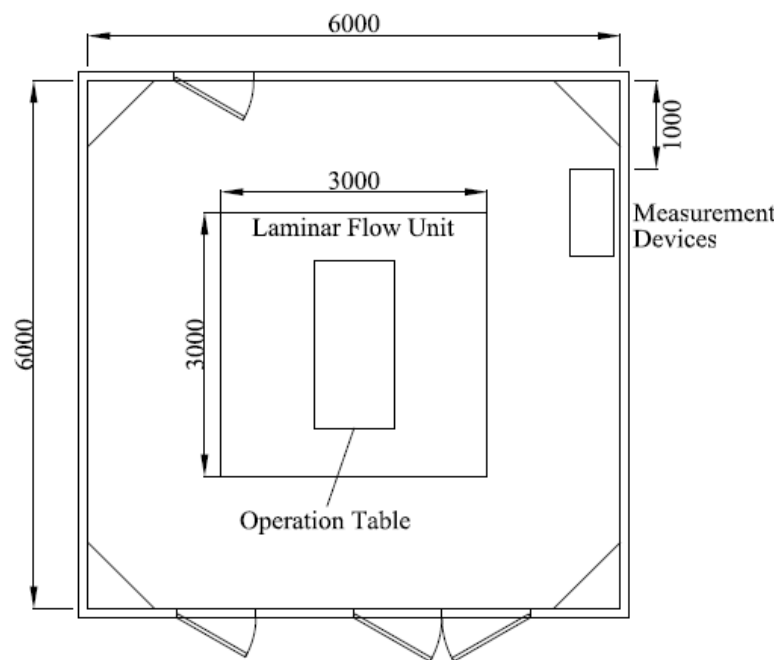

Figure 9.8. Schematic view of the operating room

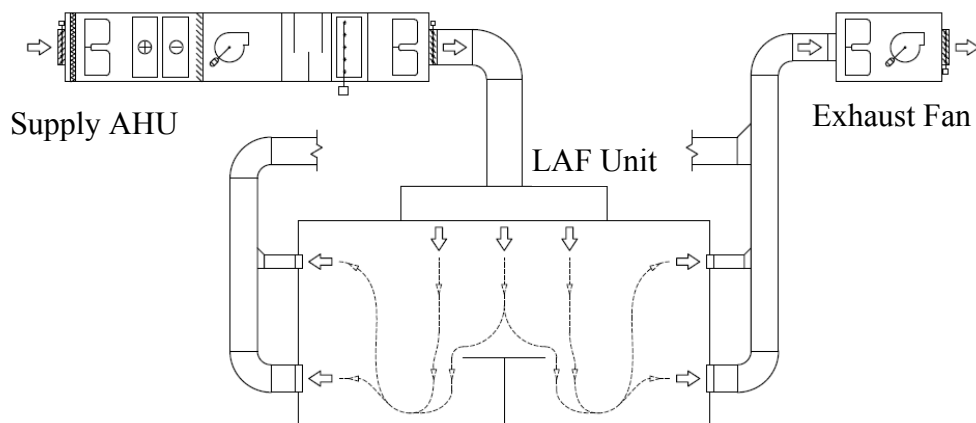

Figure 9.9. Schematic view of the HVAC system serving to the operating room

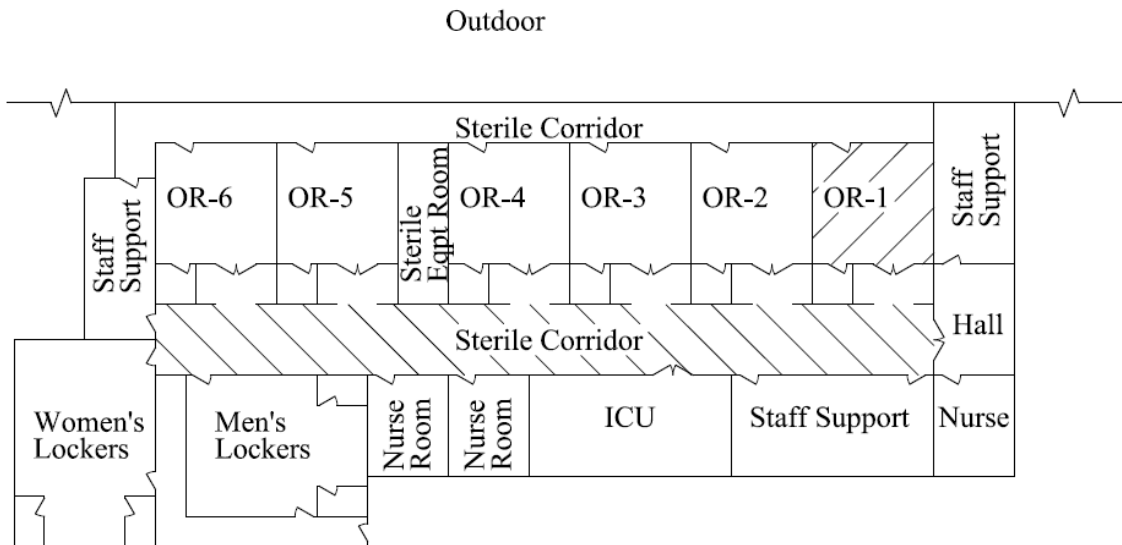

Figure 9.10. Schematic view of the operating suite showing the locations of the sterile corridor and the operating room used for the measurements



Figure 9.11. Data logger, transducers and particle counter set-up in the operating room environment

Particle counter is programmed such that to measure number of particles in 1 liter of air for five-minute intervals. The counted particles sizes were 5, 1, 0.5 and 0.3  $\mu\text{m}$ . The particle counter stored the measured data in its internal memory, which can hold 3000 sample data. Then, the stored data was transferred to a portable computer via

HyperTerminal through the serial port RS-232. The measured particle data was imported to Microsoft Excel in order to analyze and draw particle counts with respect to time for each day. Particle counts versus time graphs were formed on a daily basis and the information given by these graphs were evaluated.

For the measurement of the thermal comfort parameters INNOVA 1221 Data Logger from LumaSense Technologies with thermal comfort module was used. The thermal comfort module consisted of three transducers which measure the room temperature, absolute humidity and air velocity. The data logger was continuously connected to a portable computer and the measured data were transferred to the portable computer via INNOVA 7701 software. The data logger was programmed such that to collect data for every 2.5 minutes. Then, the collected and calculated data which were mean room temperature, relative humidity and air velocity, were imported to Microsoft Excel in order to analyze them. Graphs of collected data versus time were created and the information is evaluated in accordance with the activity level in the room.

The measurements were done for a week from October 22<sup>nd</sup> to October 28<sup>th</sup>. After the measurements done in the operating room, the devices were set up in the sterile corridor and stayed from October 28<sup>th</sup> to October 31<sup>st</sup> for almost 17 hours. In the operating room a continuous flow of personnel or material occurred during above period.



Figure 9.12. Measurement devices in sterile corridor

The automatic control system of HVAC system serving the operating suite collects the supply air data once in every 15 minutes. The system collects data for supply air temperature and relative humidity. These collected data was shown with the room air temperature and relative humidity in the diagrams. Also the information about the type of operation, number of personnel and the occupied times of the operating room was collected from the operating suite staff. This information was used for evaluating the gathered data.

## **9.5. Results**

The collected data during the measurements are given via diagrams from Figure 9.13 to 9.62 on a daily basis. Table 9.1 shows the occupancy of the operating room during the experimented period. As seen from table, the operating room was occupied with cardiovascular surgery in the first two days. The surgery was started at 08.30 and continued up to 15.00 for the both days. The second two days were the weekend and the operating room was not used. The first day of the next week (27.10.2008) was a busy day for the operating room. A cardiovascular surgery was done between 8.00 and 13.00. Then a plastic surgery was completed between 14.00 and 15.00. It was followed by an urologic surgery from 15.00 to 16.00. As for the last procedure completed in the room, a general surgery procedure was done. On Tuesday, which was 28.10.2008, a general surgery was performed between 11.00 and 16.00. The operating room was “at rest” from 18.00 to 08.00 and that is why the occupancy of this period is not mentioned in the table. The number of personnel for a cardiovascular procedure was 10 persons. For other types of surgeries, 5 persons were occupied in the operating room.

Table 9.1 Occupancy timetable of tested operating room

Time	23.10.2008	24.10.2008	25.10.2008	26.10.2008	27.10.2008	28.10.2008
08.00	Cardiovascular Surgery	Cardiovascular Surgery	EMPTY	EMPTY	Cardiovascular Surgery	General Surgery
09.00						
10.00						
11.00						
12.00					Plastic Surgery	
13.00						
14.00					Urology	
15.00						
16.00	General Surgery					
17.00						
18.00						

### 9.5.1. October 23<sup>rd</sup>

On this day, a cardiovascular surgery procedure had been completed in the operating room. The temperature of the operating room is maintained at around 23°C at night. As seen from Figure 9.13 the room temperature starts decreasing gradually at 8.00 down to 16°C which is the desired temperature for this kind of operations. The room temperature is increased steeply around 13.00 by the surgical staff. The requirement of the steep temperature change in the operating room for cardiovascular surgery was mentioned before, in Chapter 2 of this study. From the same graph, it can be seen that the supply air temperature is almost lower than the room temperature to compensate heat loads in the operation room. The low temperature is also useful to maintain a laminar stream that flows down to the floor level.

Figure 9.14 shows the variation of relative humidity and room temperature on 23<sup>rd</sup> October. It is seen that the relative humidity of the operating room is kept at around 45% at night when the room temperature is around 24°C. With the start of the surgery, the level of the relative humidity increases since the temperature of the room decreases. The relative humidity rises to around 75%. Then, by the increase of the room temperature, relative humidity decreases to approximately 35%. The decrease of the room temperature causes increase of relative humidity and it attains to 80%. This figure

shows that the relative humidity in the room is highly influenced from the room temperature rather than humidity sources such as devices, people etc.

From Figure 9.15 which shows the change of air velocity with respect to time, it is observed that the velocity of air is increased when the activity in the room was started. In addition to this increase, the difference between the minimum and the maximum values of velocity is also increased. The level air velocity values are low, around 0.07 m/s which refers to a laminar flow in the operating room. The location of transducers near the wall of the operating room may be another reason for the measured low air velocity.

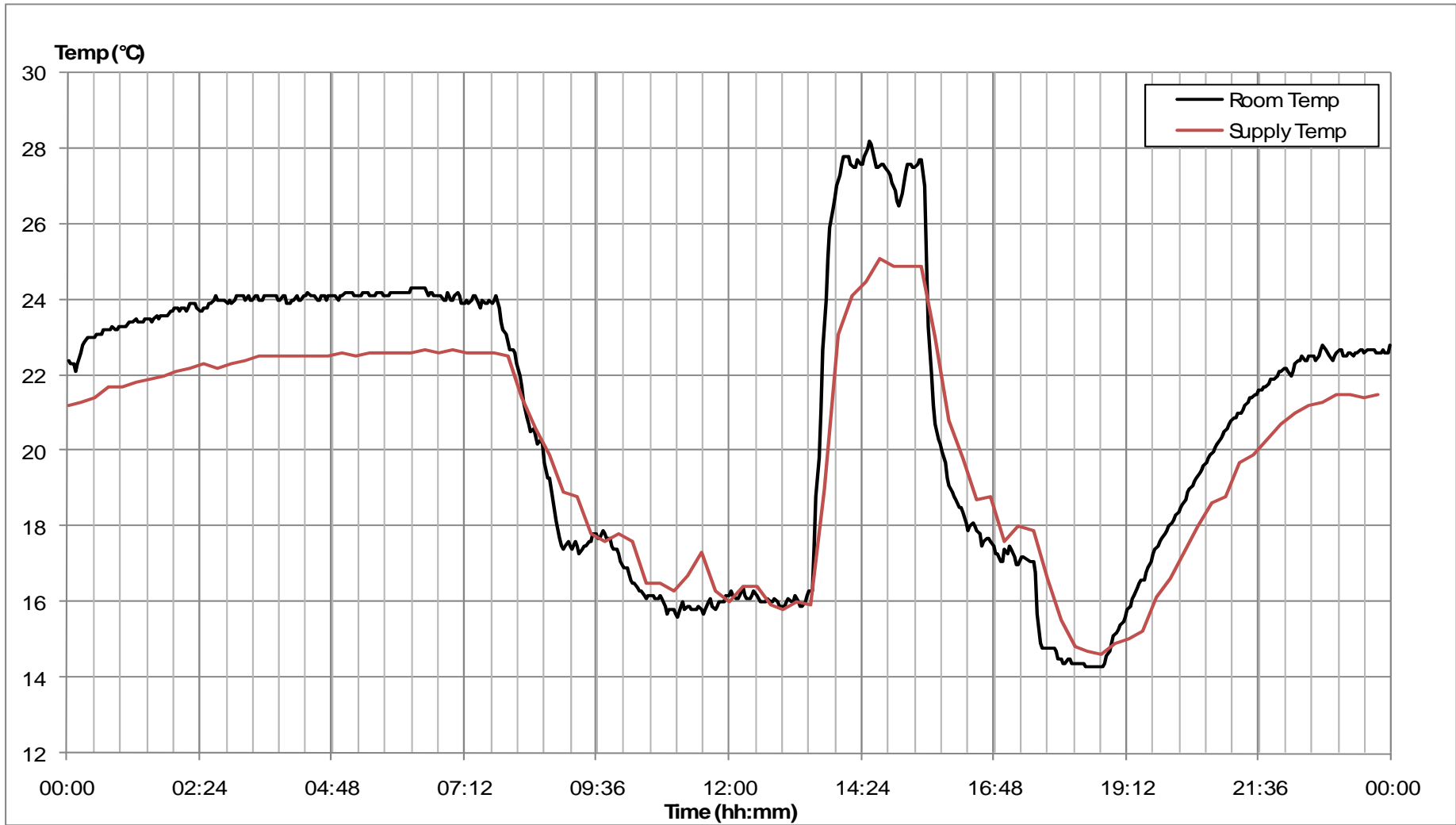

Figure 9.13. Room and supply air temperature values of operating room on October, 23<sup>rd</sup>



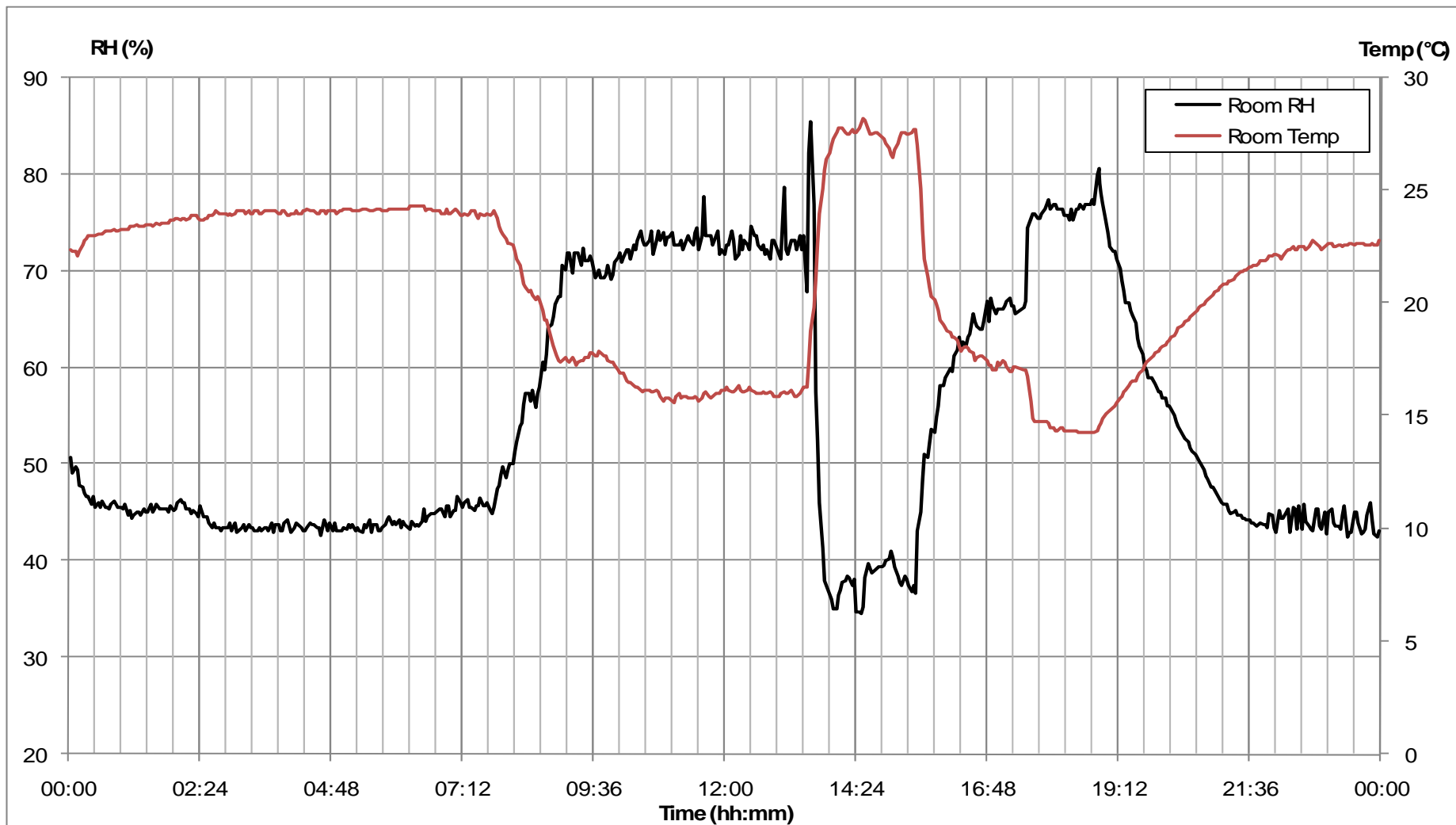

Figure 9.14. Relative humidity values of room and supply air on October 23<sup>rd</sup>

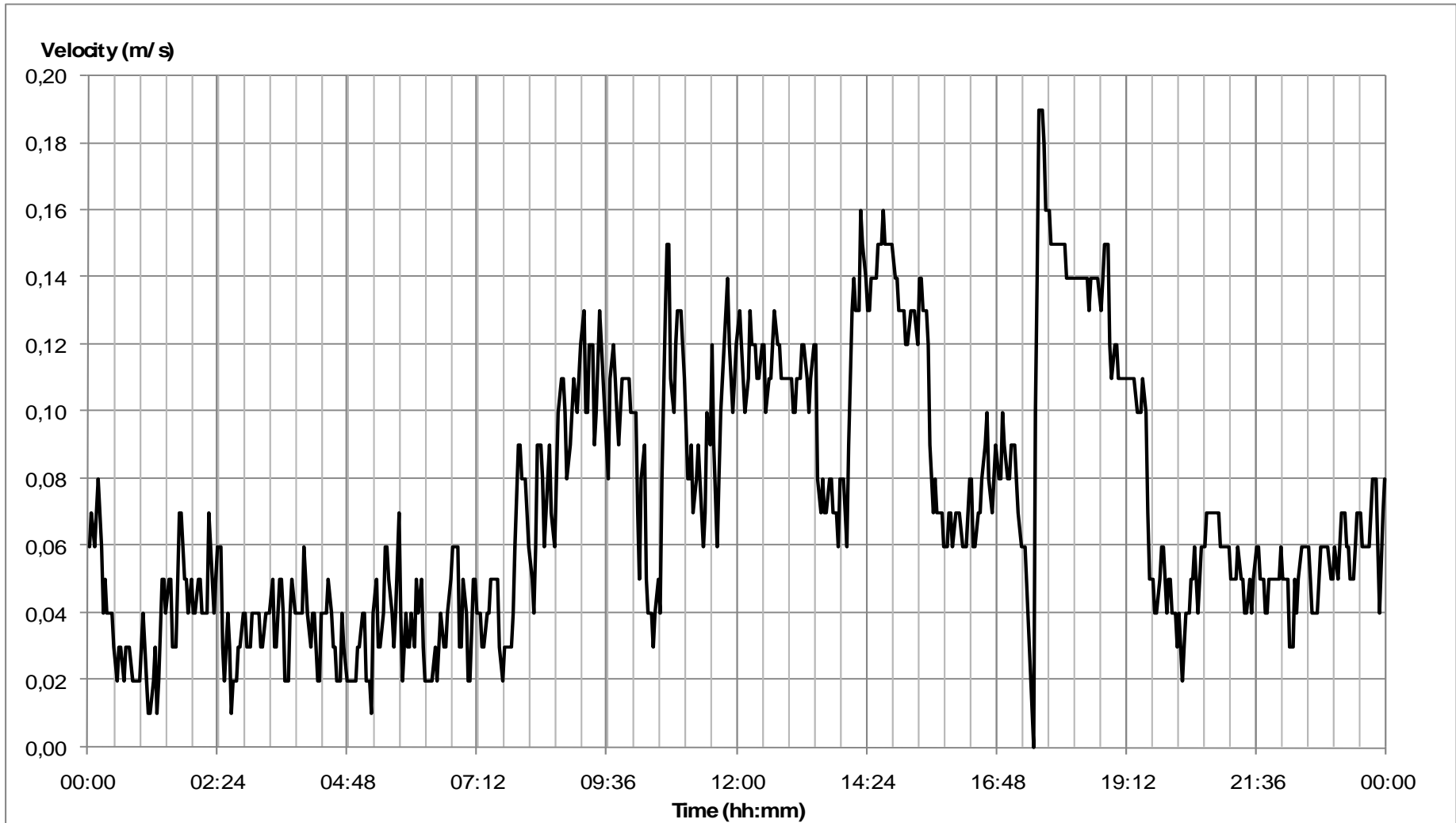

Figure 9.15. Air velocity in the operating room, October 23<sup>rd</sup>

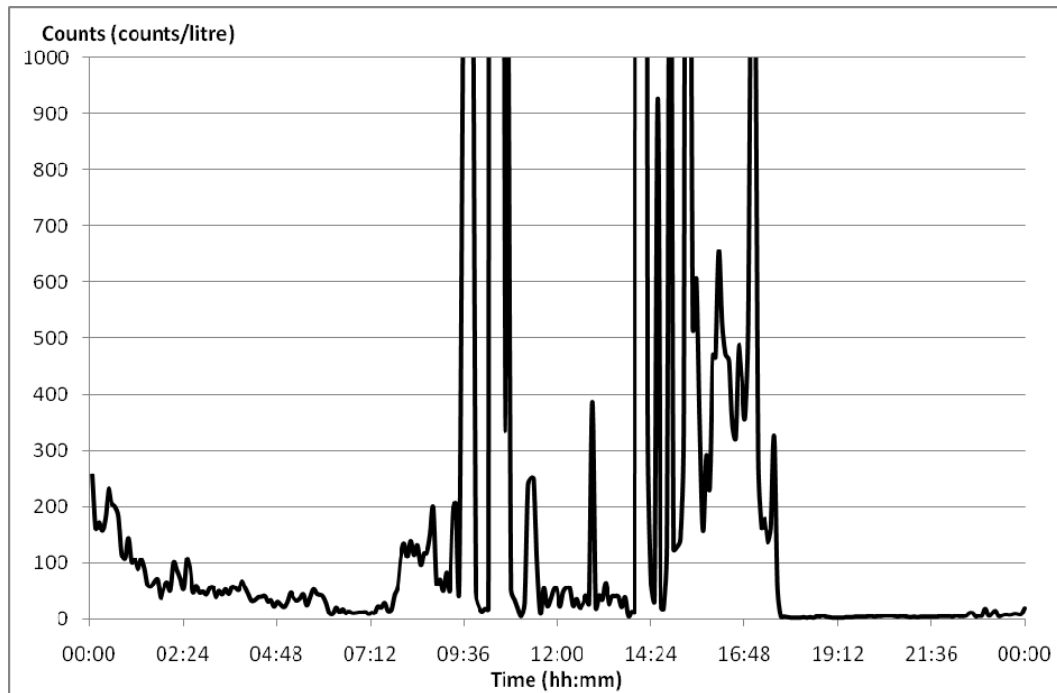

Figure 9.16. 0.3 micron particle count, October 23<sup>rd</sup> (counts/liter)

The particle count data is presented from Figure 9.16 to 9.19. It is clearly observed that the particle count is very low in “at rest” condition; however, it dramatically increases during surgery. The particle concentration rises when the activity level in the room increases. Opening and closing of the doors and movement of the personnel, operation of devices in the room are the main reasons for the increase of particle concentration in the operating room.

As expected, the numbers of generated particles with 0.3 microns and 0.5 microns sizes during the surgery are considerably higher than 1.0 and 5.0 micron particles. The number of the particles in the operating room highly depends on activities of personnel and number of entrance. The steep increases in number of particles are observed around 9.00 and 14.00 due to high staff activity and high number of entry. It should be mentioned that 9.00 and 14.00 are hours correspond to the start and end of operation in which activity is relatively higher.

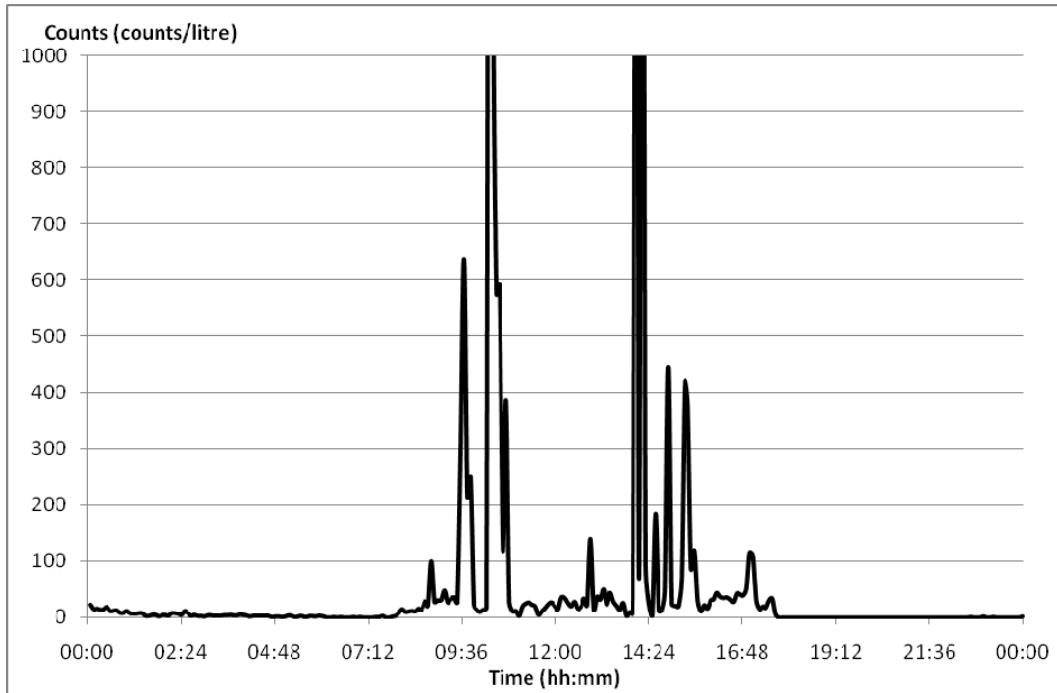

Figure 9.17. 0.5 micron particle count, October 23<sup>rd</sup> (counts/liter)

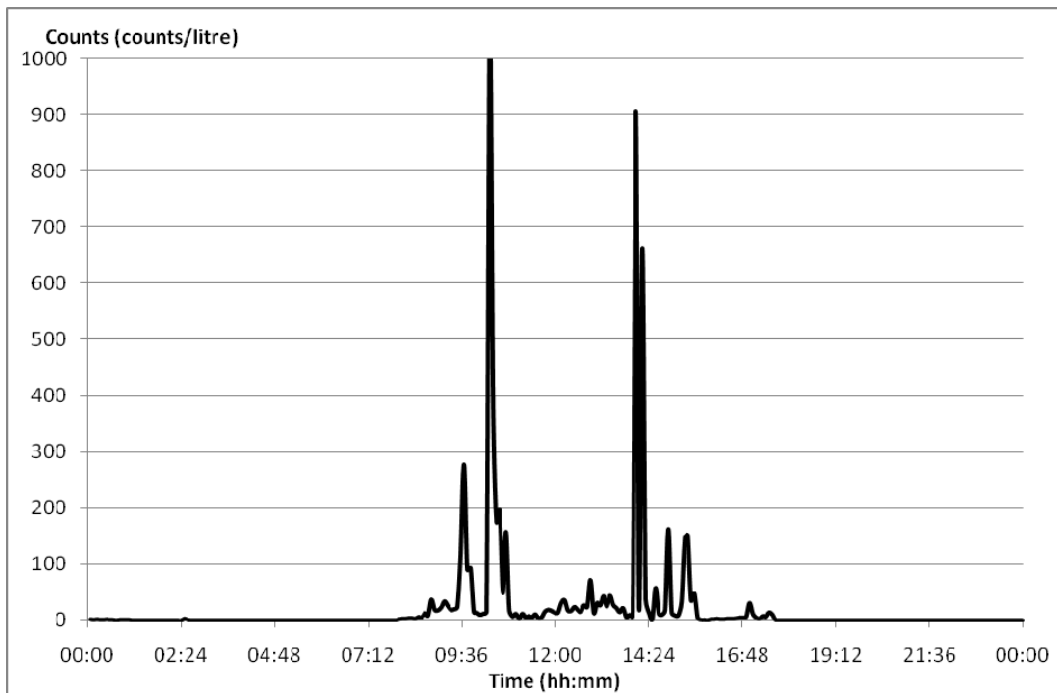

Figure 9.18. 1.0 micron particle count, October 23<sup>rd</sup> (counts/liter)

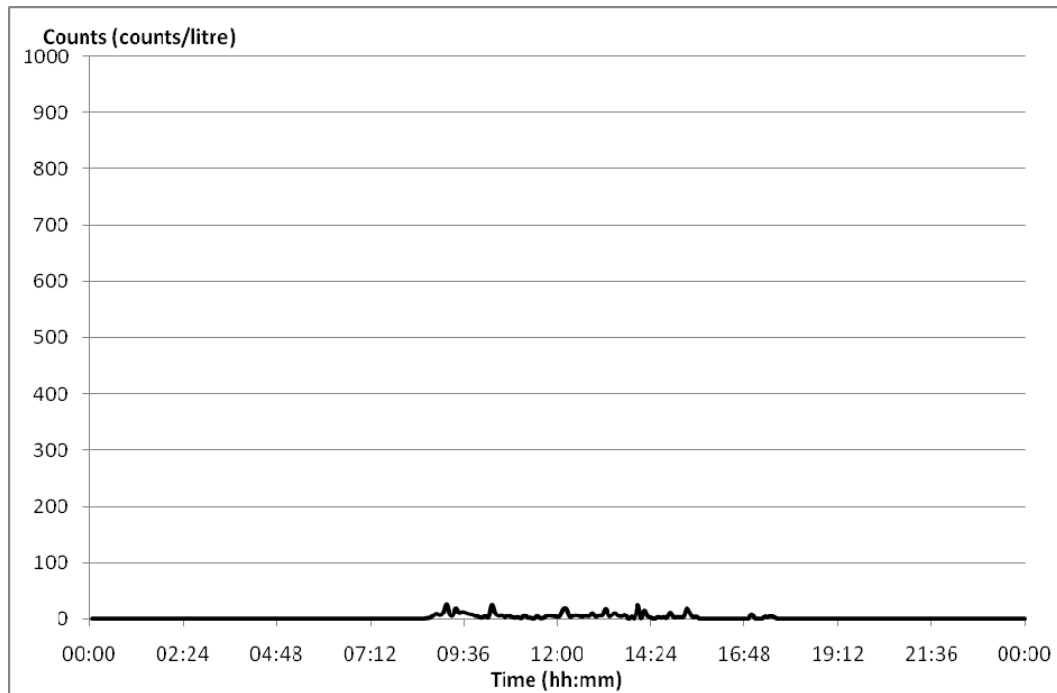

Figure 9.19. 5.0 micron particle count, October 23<sup>rd</sup> (counts/liter)

### 9.5.2. October 24<sup>th</sup>

On October 24<sup>th</sup>, there was another cardiovascular operation like the previous day. Figure 9.20 shows the variation of room temperature during 24 hours. As it is seen, the room temperature is around 23°C from 00.00 to 6.30 and it is reduced to around 13°C and maintained around 15°C up to 19.00. The temperature is increased gradually to 21°C after 19.00. Similar to the previous day this operation, which was a cardiovascular operation, was performed in low temperature around 15°C. However, due to some problems faced during the operation and according to the decision of surgery team, a steep increase of temperature was not performed at the end of this operation.

The relative humidity diagram is shown in Figure 9.21. It is seen that the HVAC system maintains a constant relative humidity level of around 45% at 24°C during the night. The temperature of the room is decreased by the start of the surgical operation and in accordance with this drop, the relative humidity ratio of the room is increased from 45% up to 90%. For the rest of the surgical operation, it is seen that the relative humidity level of the room changes in accordance with the temperature of the room.

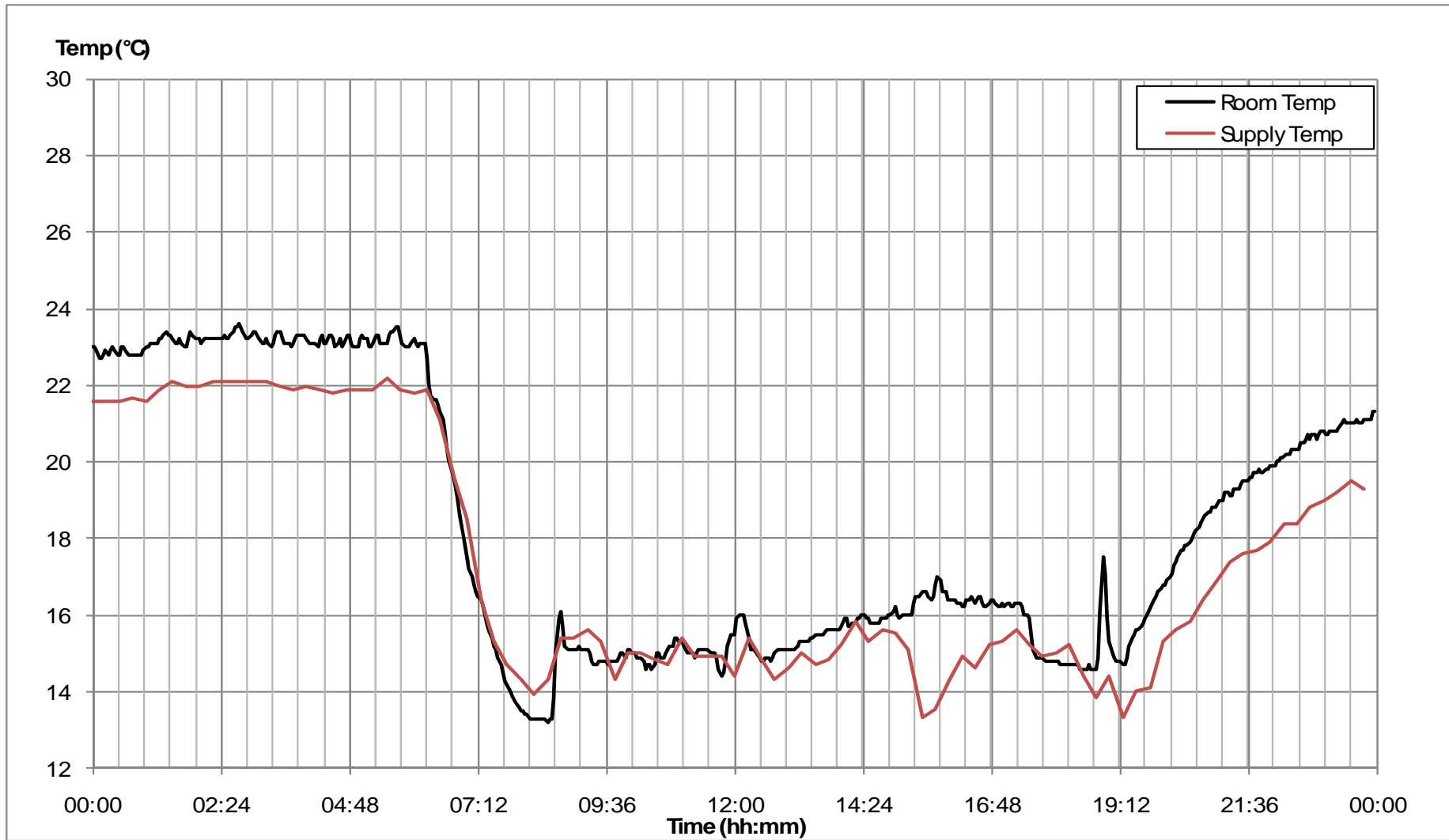

Figure 9.20. Room and supply air temperature values of operating room on October, 24<sup>th</sup>

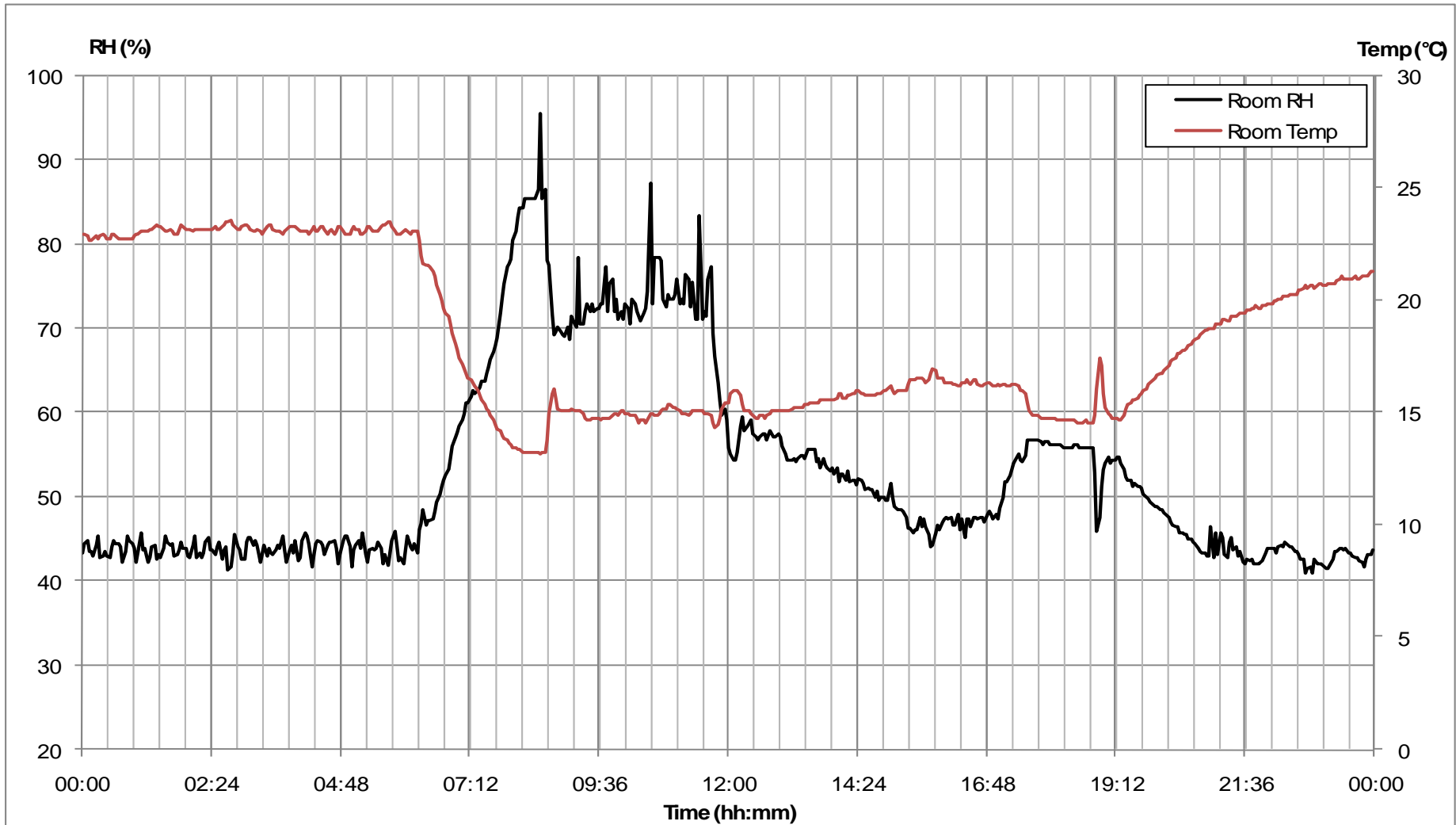

Figure 9.21. Relative humidity values of room and supply air on October 24<sup>th</sup>

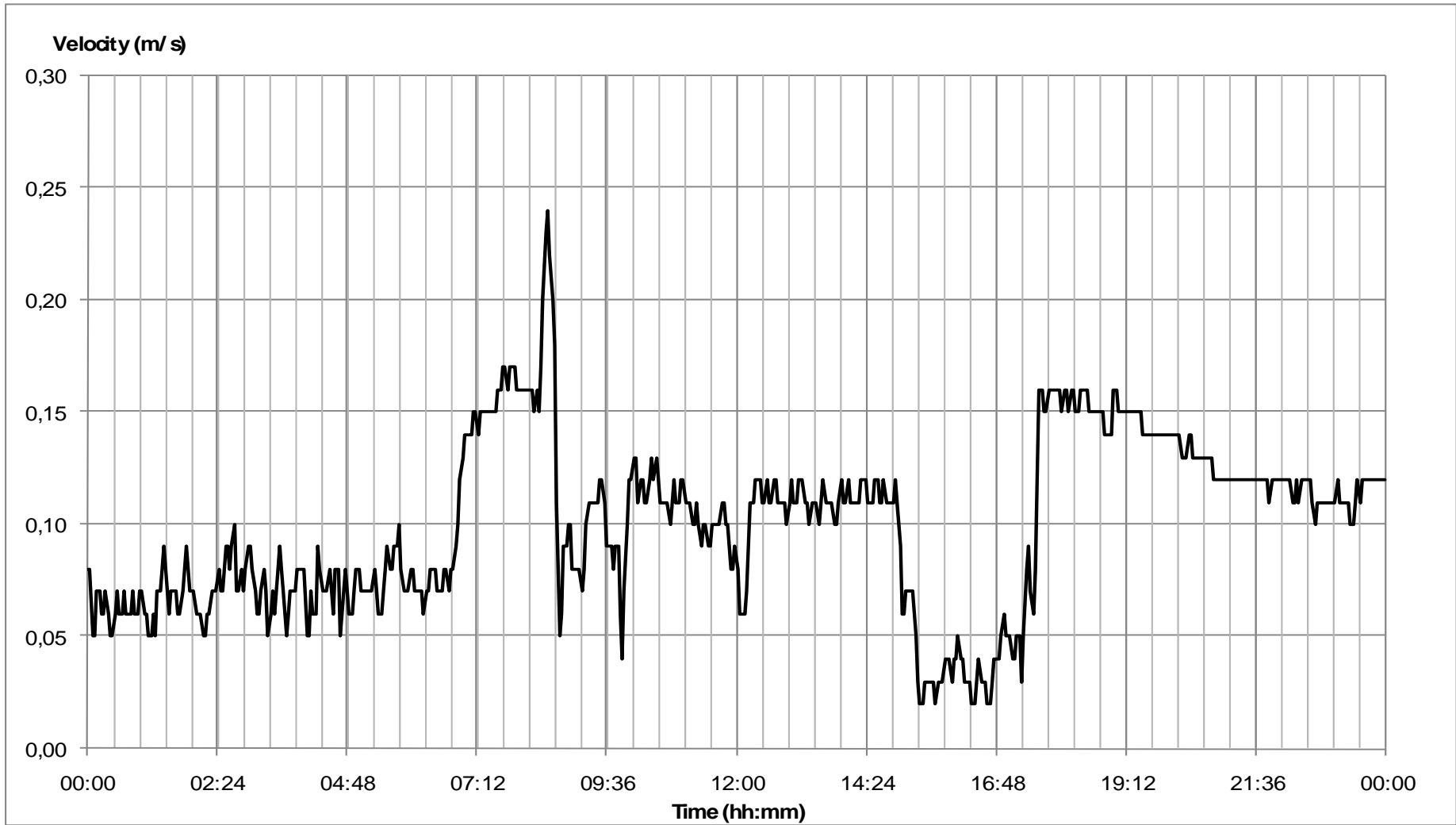

Figure 9.22. Air velocity in the operating room, October 24<sup>th</sup>



Figure 9.22 shows the distribution of air velocity in the operating room during October, 24<sup>th</sup>. From the period starting at 00.00 to 7.00 the average of the air velocity is 0.07 m/s. Steep increase is observed for the period between 7.00 and 9.00 and then the air velocity remains constant around 0.11 m/s up to 14.00. After this hour, it decreases to 0.03 m/s and increases to approximately 0.14 m/s. This variation does not match the operation program. What is expected is that very high velocity during the operation and very low velocity for the remaining period. The reason of this wrong air velocity distribution may be the measurement errors.

The particle concentration in the room air is shown in Figures from 9.23 to 9.26 for four different particle sizes as 0.3, 0.5, 1.0 and 5.0 microns. One can observe that the particle concentration in the room had increased by the start of the movement of the operation personnel. Similar to the particle distribution of previous cardiovascular surgery the numbers of 0.3 and 0.5 micron particles are very high during the operation and they are zero for the remaining period in which no activity exists in the operation room. These values decreases for 1.0 and 5.0 micron particles as expected.

The raise in the particle count at around 17.00 is probably the result of an entrance to the operating room for arrangement of the equipment or cleaning purposes. It is remarkable that the particle concentration in the room air had risen almost at the same time on 23<sup>rd</sup> October.

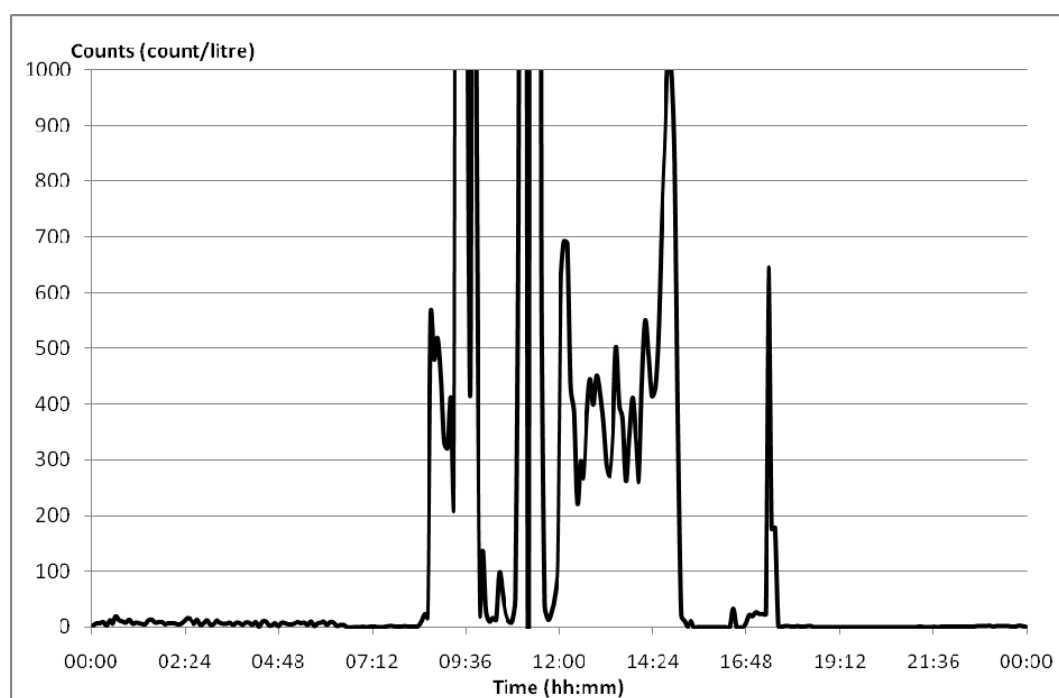

Figure 9.23. 0.3 micron particle count, October 24<sup>th</sup> (counts/liter)

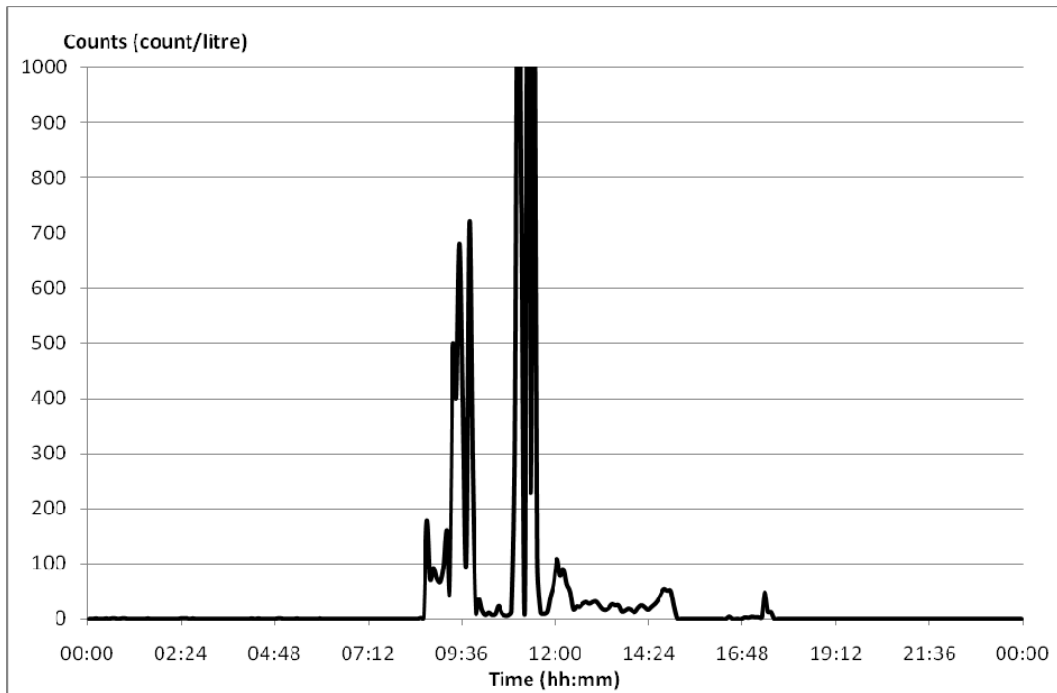

Figure 9.24. 0.5 micron particle count, October 24<sup>th</sup> (counts/liter)

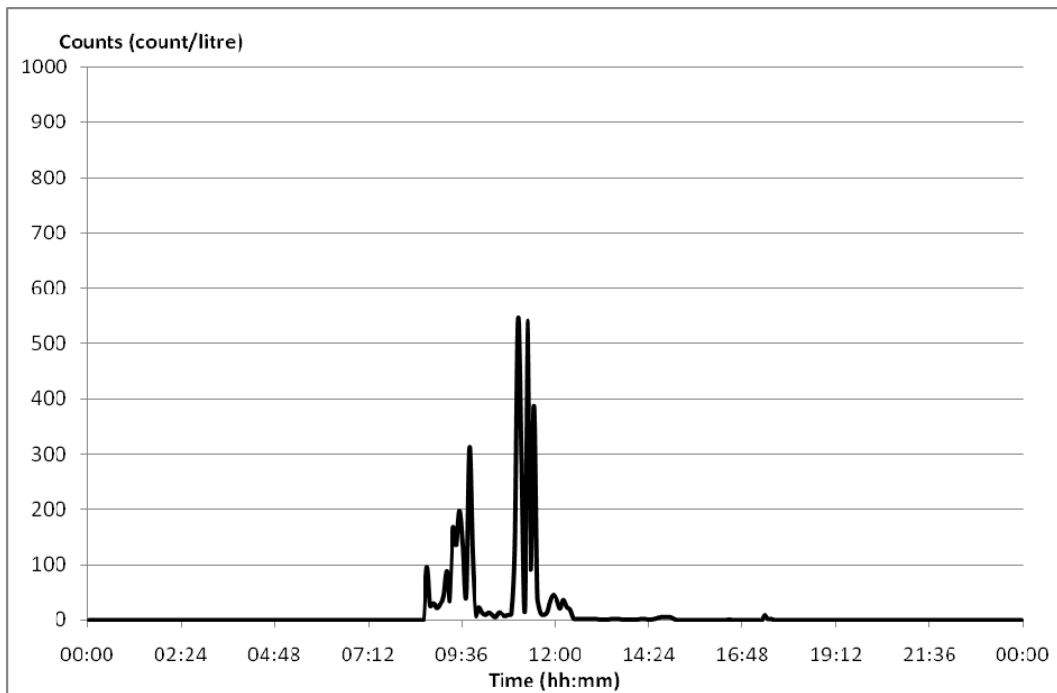

Figure 9.25. 1.0 micron particle count, October 24<sup>th</sup> (counts/liter)

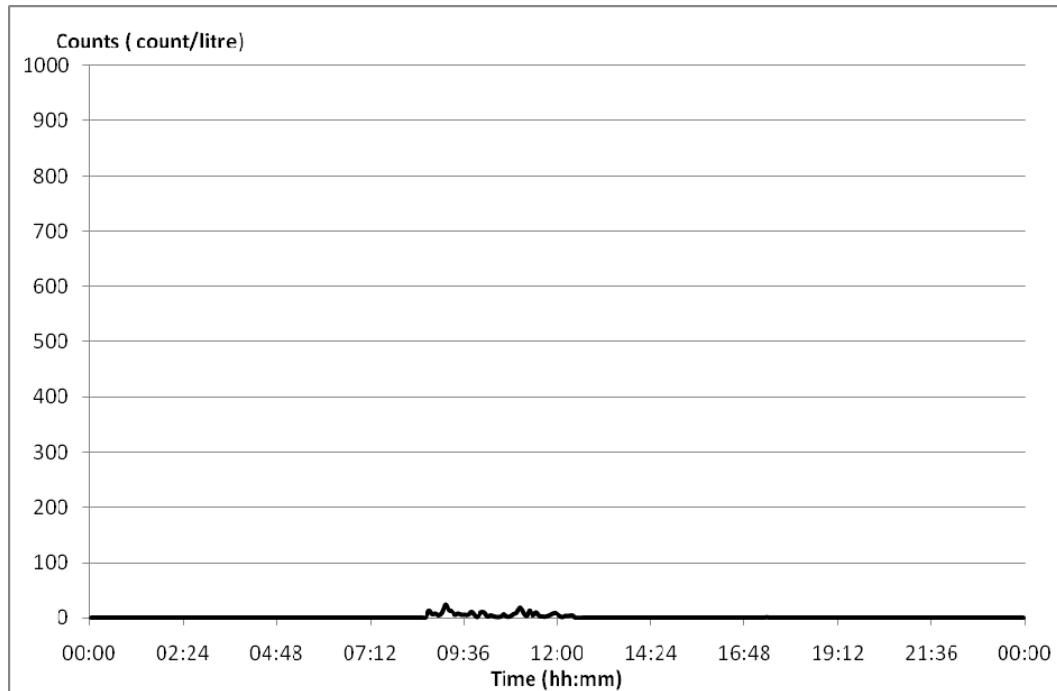

Figure 9.26. 5.0 micron particle count, October 24<sup>th</sup> (counts/liter)

### 9.5.3. October 25<sup>th</sup> and 26<sup>th</sup>

On 25<sup>th</sup> and 26<sup>th</sup> October the operating room was at rest since these days were weekend. As seen from Table 9.1 there was no surgical operation on these days but entrance of operating suite personnel may have been occurred.

As seen from Figure 9.27 there exists a strange fluctuation in the room and supply air temperatures during the period between 1.00 and 5.00. Unlike the previous day's applications during night, the operating room temperature is not maintained at 23°C. When the reason of this fluctuation was asked to the responsible technical and medical personnel, no convincing reply was received. Most probably wrong adjustment of temperature by the operating suite staff is the reason of this fluctuation. The room temperature is around 23°C for the remaining of the day.

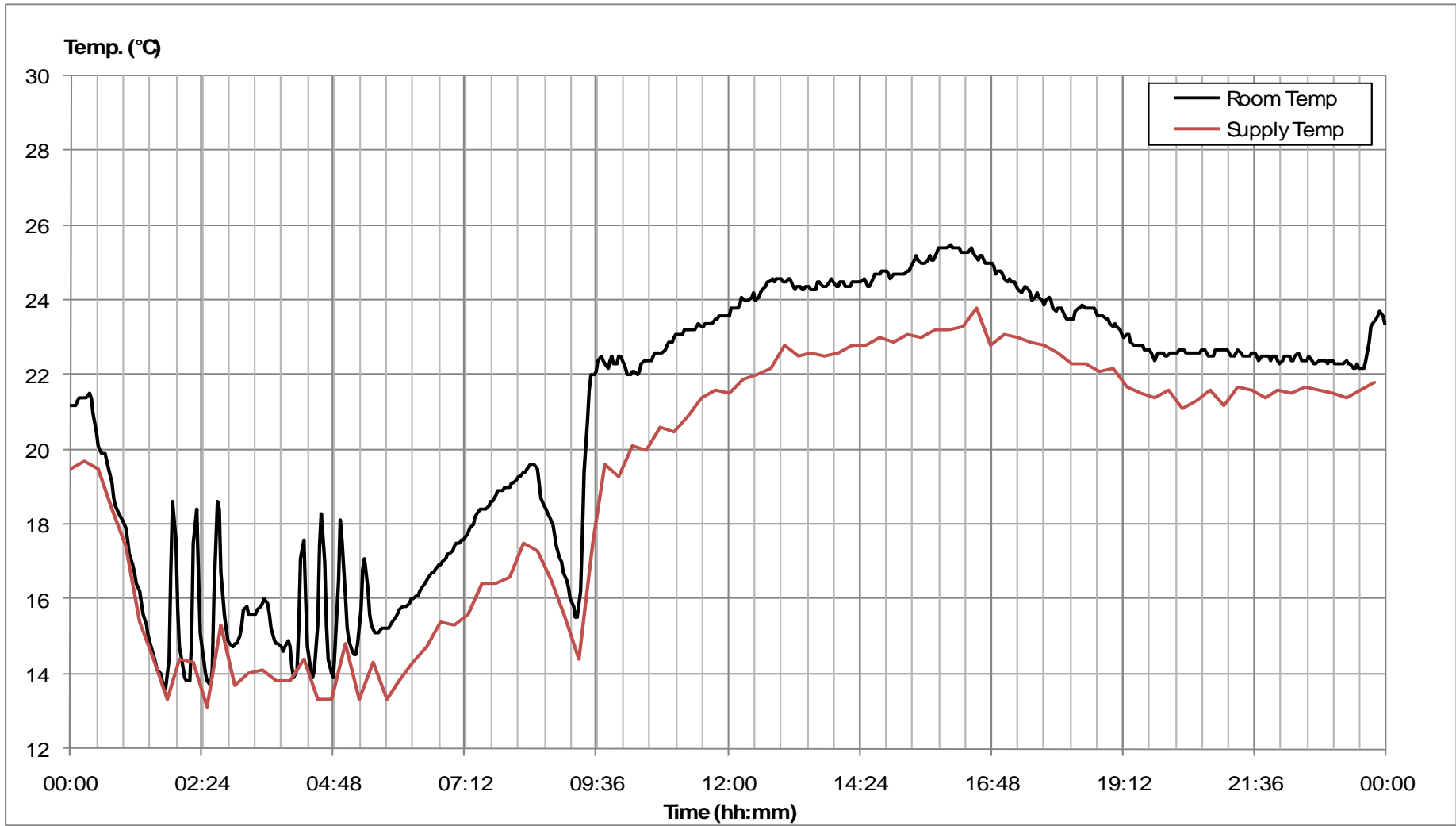

Figure 9.27. Room and supply air temperature values of operating room on October, 25<sup>th</sup>

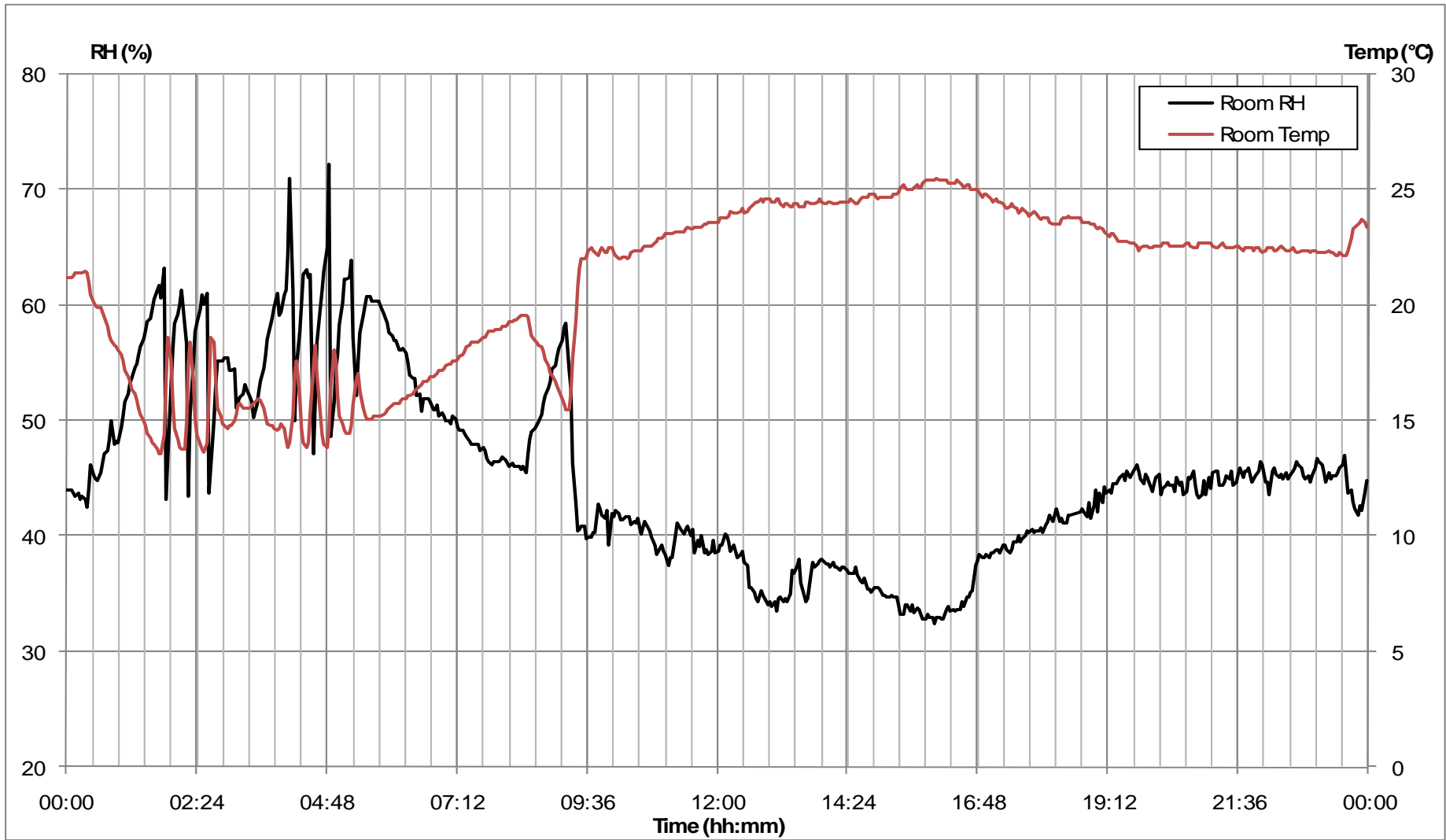

Figure 9.28. Relative humidity values of room and supply air on October 25<sup>th</sup>

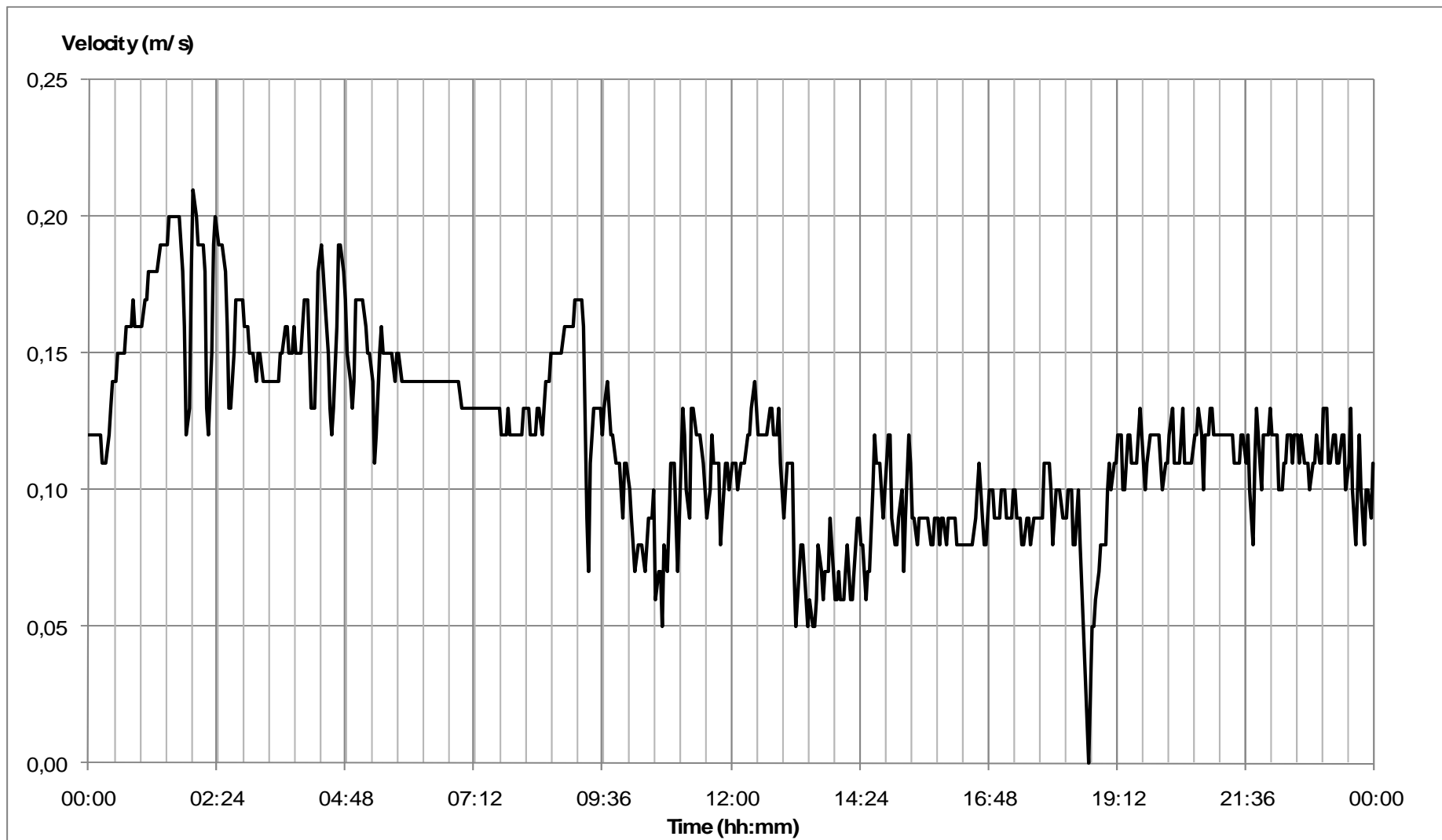

Figure 9.29. Air velocity in the operating room, October 25<sup>th</sup>

Since the relative humidity depends greatly on the temperature of the air, the same fluctuation is observed in the relative humidity diagram shown in Figure 9.28. During that fluctuation, the relative humidity of the room is maintained at levels of 55% which is relatively higher than the previous days for night period.

It is difficult to comment on the distribution of air velocity on 25<sup>th</sup> October. The average air velocity is around 0.12 m/s which is a high value for an operating room at rest. The reason of this wrong distribution may be measurement errors.

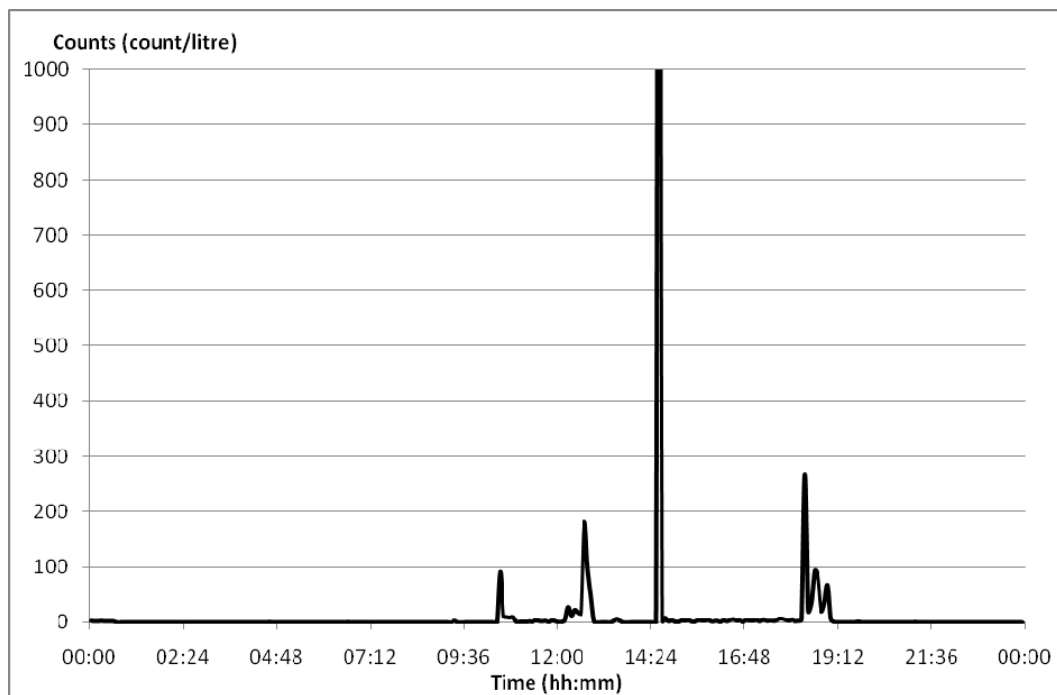

Figure 9.30. 0.3 micron particle count, October 25<sup>th</sup> (counts/liter)

The particle concentration diagrams are presented in Figures 9.30 to 9.33. It can be observed from the figures that the particle concentration is relatively lower than previous days. The number of the all particle sizes is almost zero in 24 hours of the 25<sup>th</sup> October. There are some peaks in the diagrams, which were probably caused by the entrance of responsible personnel to the operating suite.

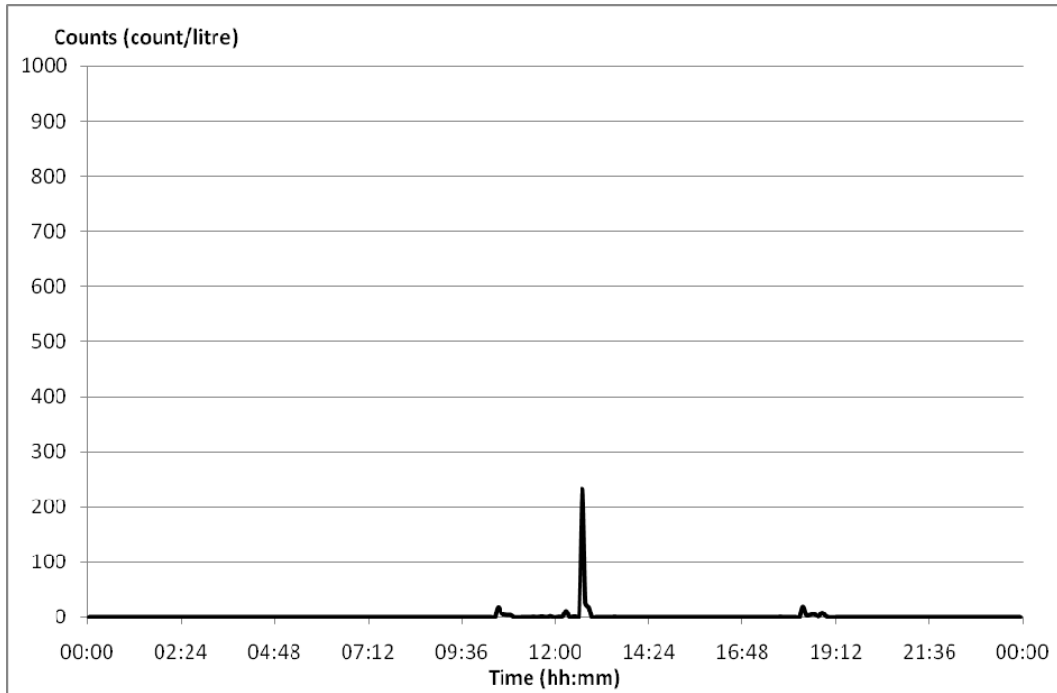

Figure 9.31. 0.5 micron particle count, October 25<sup>th</sup> (counts/liter)

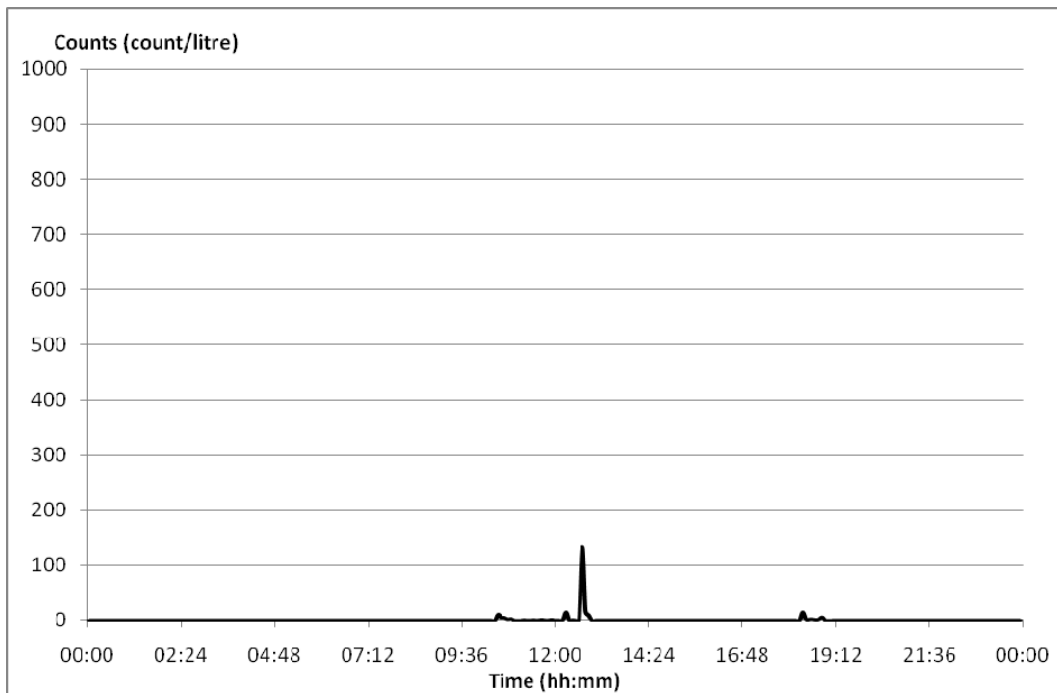

Figure 9.32. 1.0 micron particle count, October 25<sup>th</sup> (counts/liter)



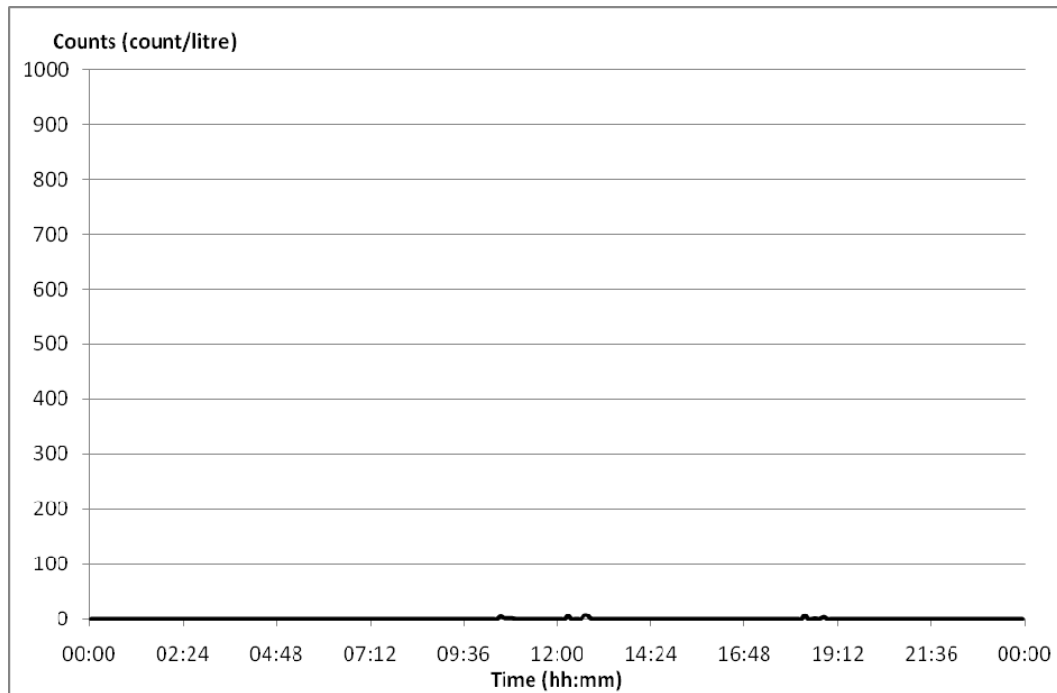

Figure 9.33. 5.0 micron particle count, October 25<sup>th</sup> (counts/liter)

The variation of the room and supply temperatures during 26<sup>th</sup> October is presented in Figure 9.34. As it is expected no fluctuation in temperatures is observed and stable distribution exists. The room temperature is above of supply temperature due to heat gains. An increase in temperature of the room during 12.00 and 17.00 is observed due to heat gain in the afternoon.

The relative humidity diagram is shown in Figure 9.35. It can be easily observed from this diagram that the relative humidity of the room changes with the temperature change. This is because the relative humidity of the air greatly depends on the temperature of the air, as mentioned previously.

The variation of the particles in the room air is shown in Figures from 9.37 to 9.40 for four different particles sizes. As seen from these diagrams the particle concentrations is almost zero throughout the day. A sharp increase is observed at 12.00 for 0.3 microns diagram, which may be caused by entry of the operating suite staff to the operation room.

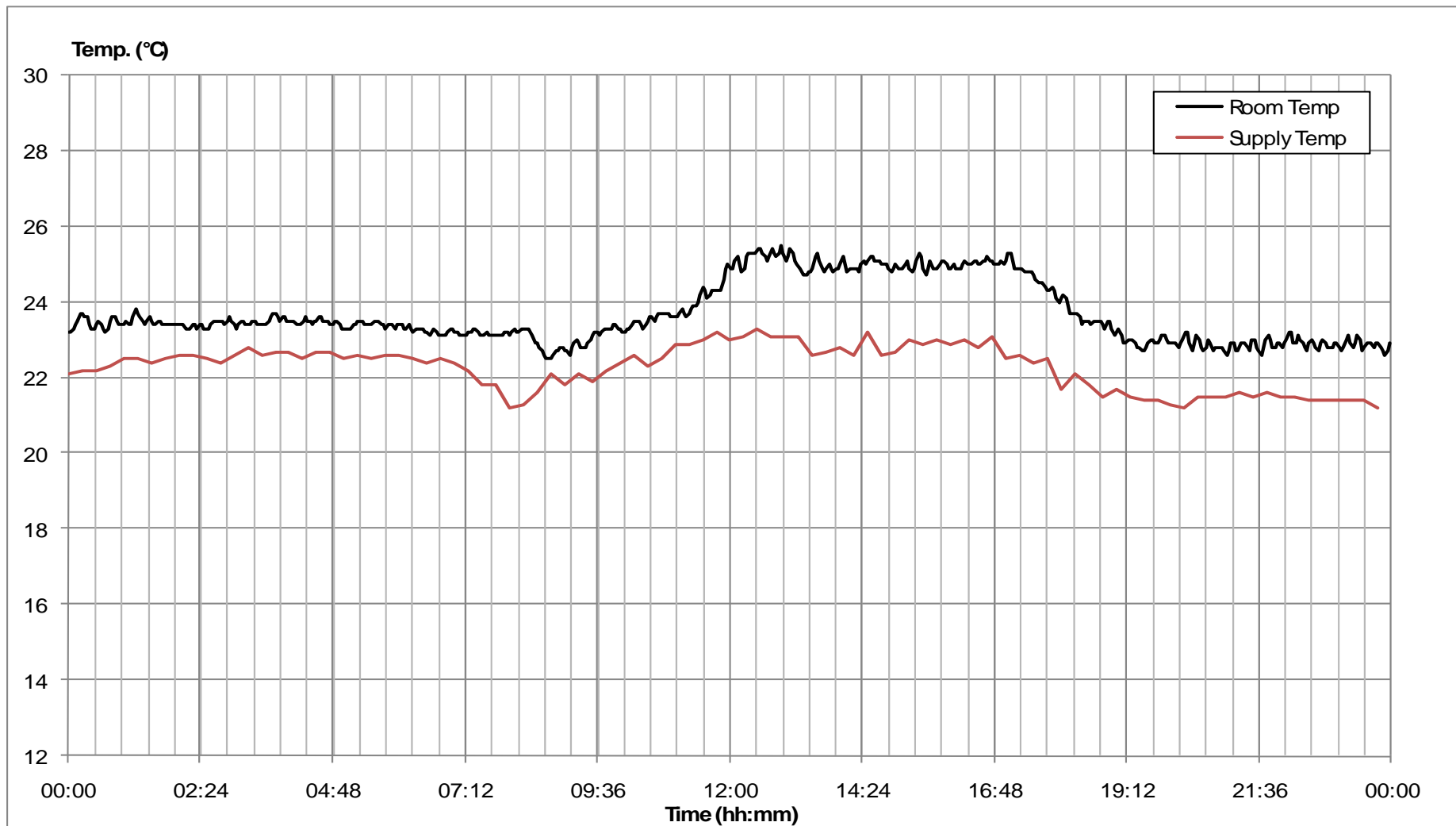

Figure 9.34. Room and supply air temperature values of operating room on October, 26<sup>th</sup>

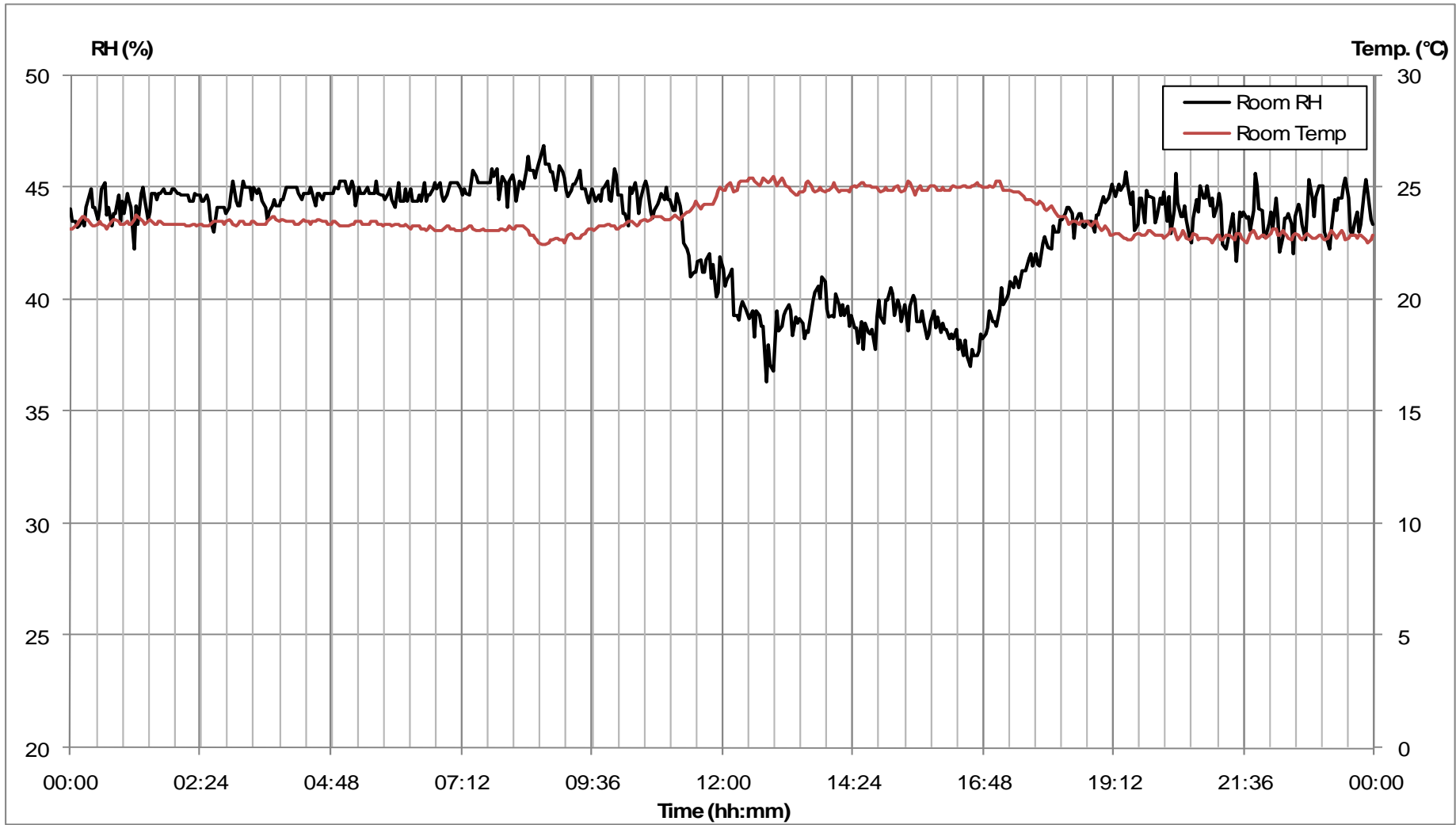

Figure 9.35. Relative humidity values of room and supply air on October 26<sup>th</sup>

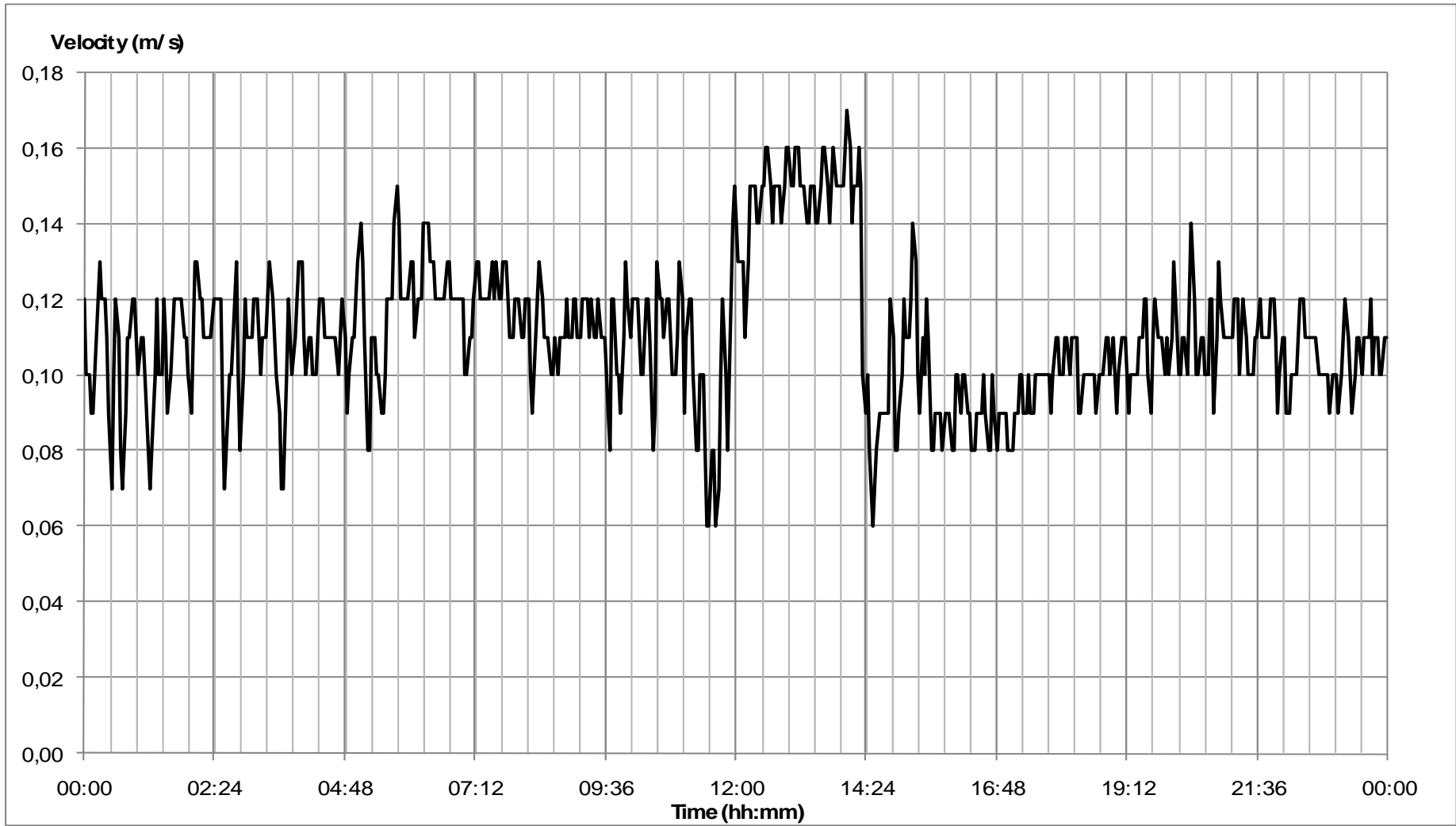

Figure 9.36. Air velocity in the operating room, October 26<sup>th</sup>

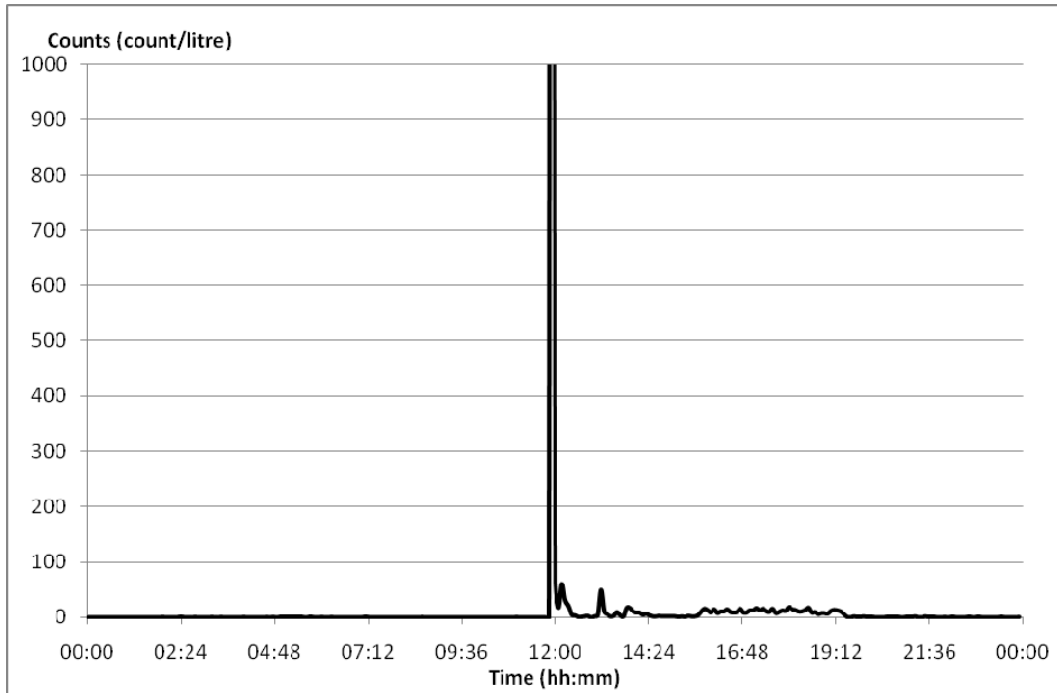

Figure 9.37. 0.3 micron particle count, October 26<sup>th</sup> (counts/liter)

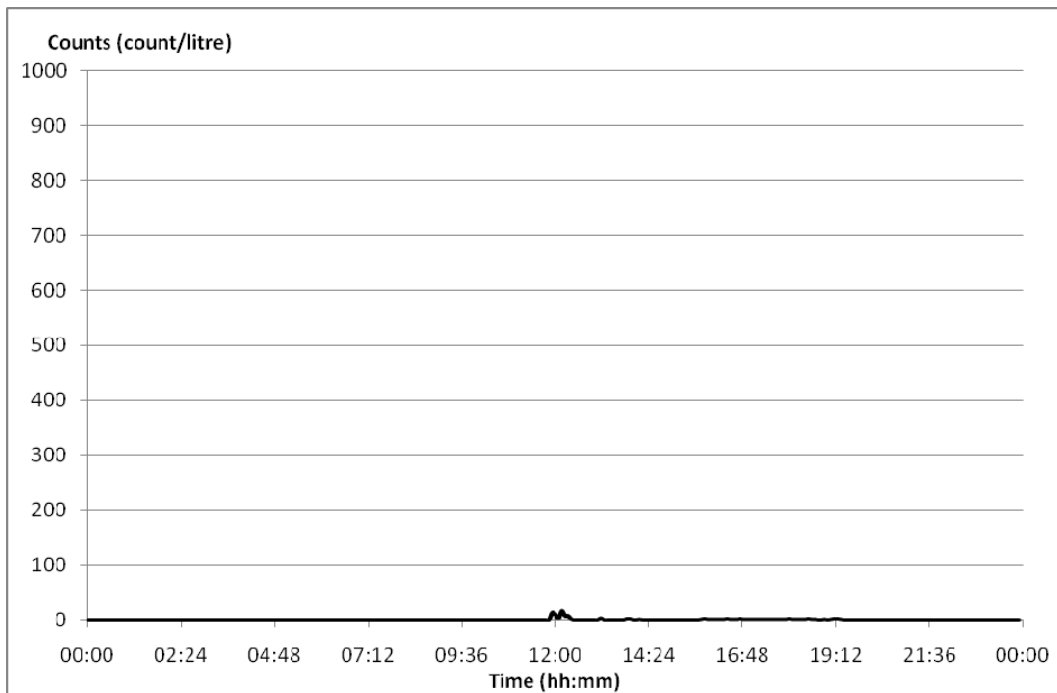

Figure 9.38. 0.5 micron particle count, October 26<sup>th</sup> (counts/liter)

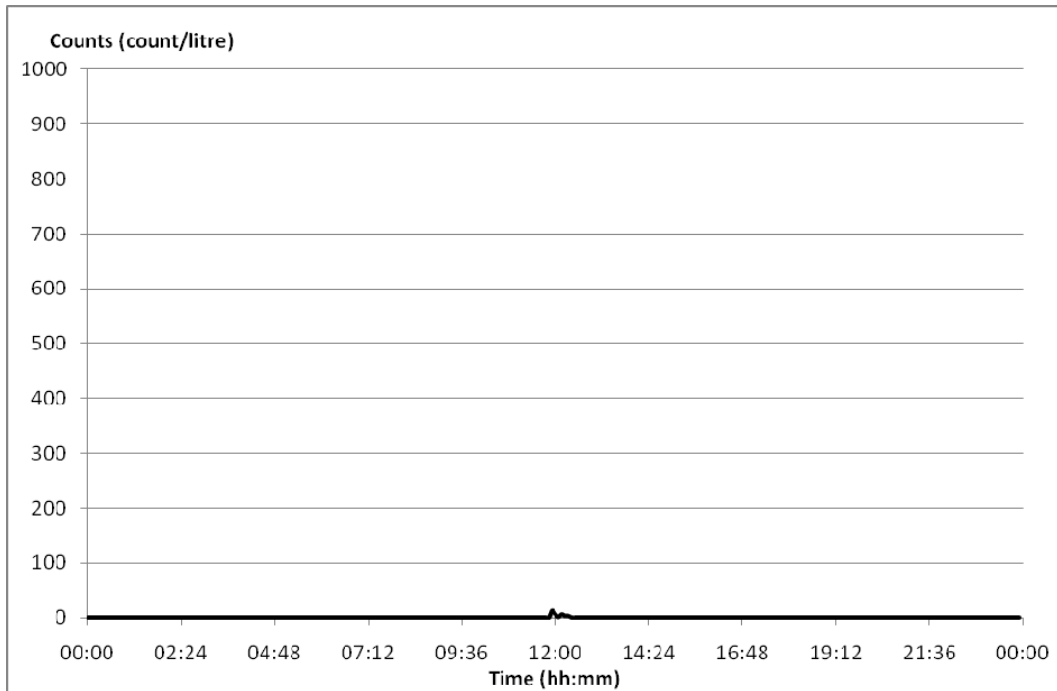

Figure 9.39. 1.0 micron particle count, October 26th (counts/liter)

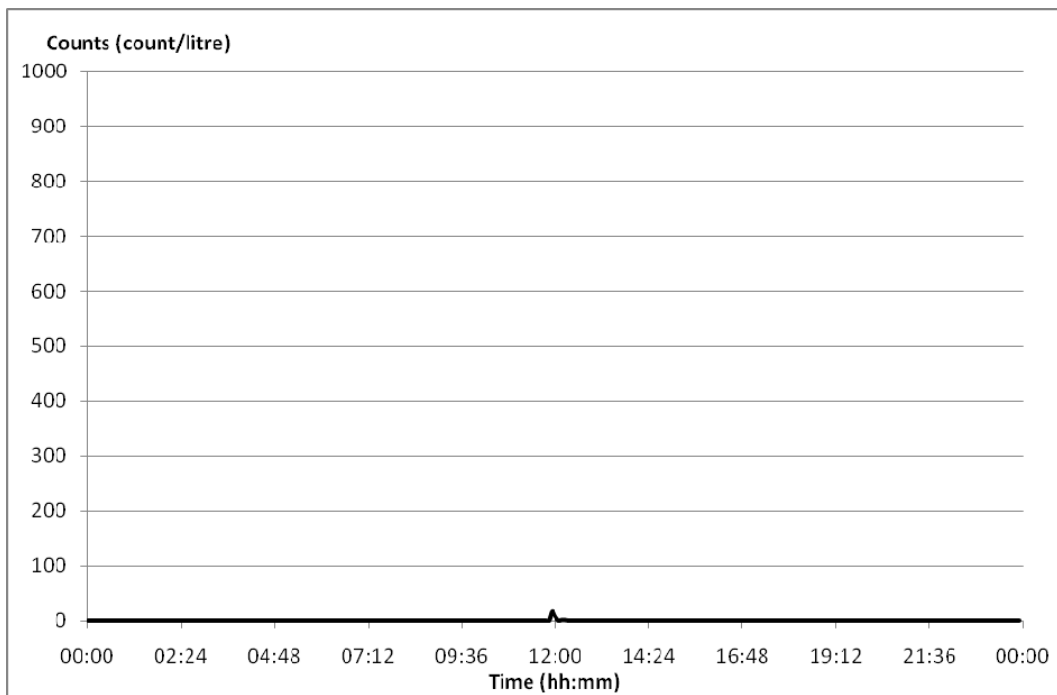

Figure 9.40. 5.0 micron particle count, October 26<sup>th</sup> (counts/liter)

#### 9.5.4. October 27<sup>th</sup>

The operating room was intensely in use on this day. As Table 9.1 shows the day was started with a cardiovascular surgery for five hours. After this operation, a plastic surgery procedure was taken place for 1 hour. It was followed by a urology surgery for 1 hour and finally a general surgery was performed for two hours. After 18.00 the operation room was at rest.

Figure 9.41 shows the change of room and supply temperatures and similar to the other nights the temperature of the room was around 23°C during the night from 00.00 to 8.00. The temperature was reduced to around 15°C before the start of the cardiovascular operation. This temperature was maintained around 16°C during the cardiovascular surgery. After finishing of this operation a plastic surgery was performed in the operating room. The room temperature was increased from 15°C to 25°C at the beginning of the operation. It was maintained around 25°C during the operation. The plastic surgery procedure was followed by a urology operation and the temperature of the operating room was reduced to 18°C during urology operation. Finally, general surgery operation was performed at around 16°C. After the 19.00 the temperature of the operating room was maintained around 24°C for the night.

As seen from Figure 9.42 the relative humidity of the room was kept at 45% at night. The temperature of the room starts to decrease at around 8.00, and an increase in the relative humidity can be observed in accordance with this decrease. When the temperature increases at around 14.30, the humidity level of the room decreases, based on the increase of the temperature. During the plastic surgery between 14.00 and 16.00, it is seen that the room temperature is higher than the night period but the relative humidity is lower, which is kept around 40%. In this region, the relative humidity level increases continuously, while the room temperature is steady. This increase probably originates from the humidification in air handling unit to raise the humidity level of the room to its normal value of 45%. For the urology and general surgery procedures, which were conducted in lower temperatures, the characteristic of the change in the humidity is the same with the cardiovascular surgery conducted on this day in the morning.

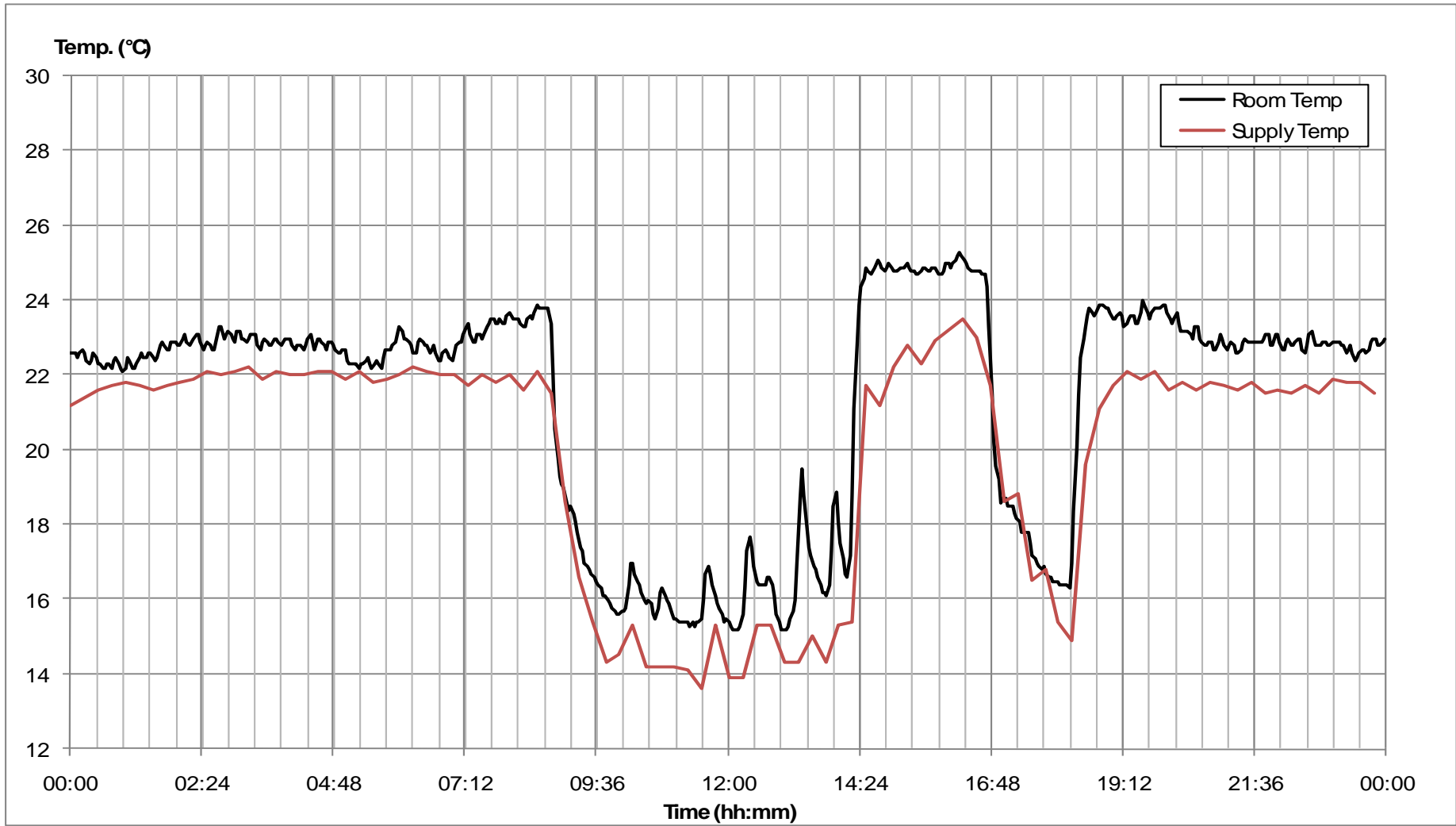

Figure 9.41. Room and supply air temperature values of operating room on October, 27<sup>th</sup>



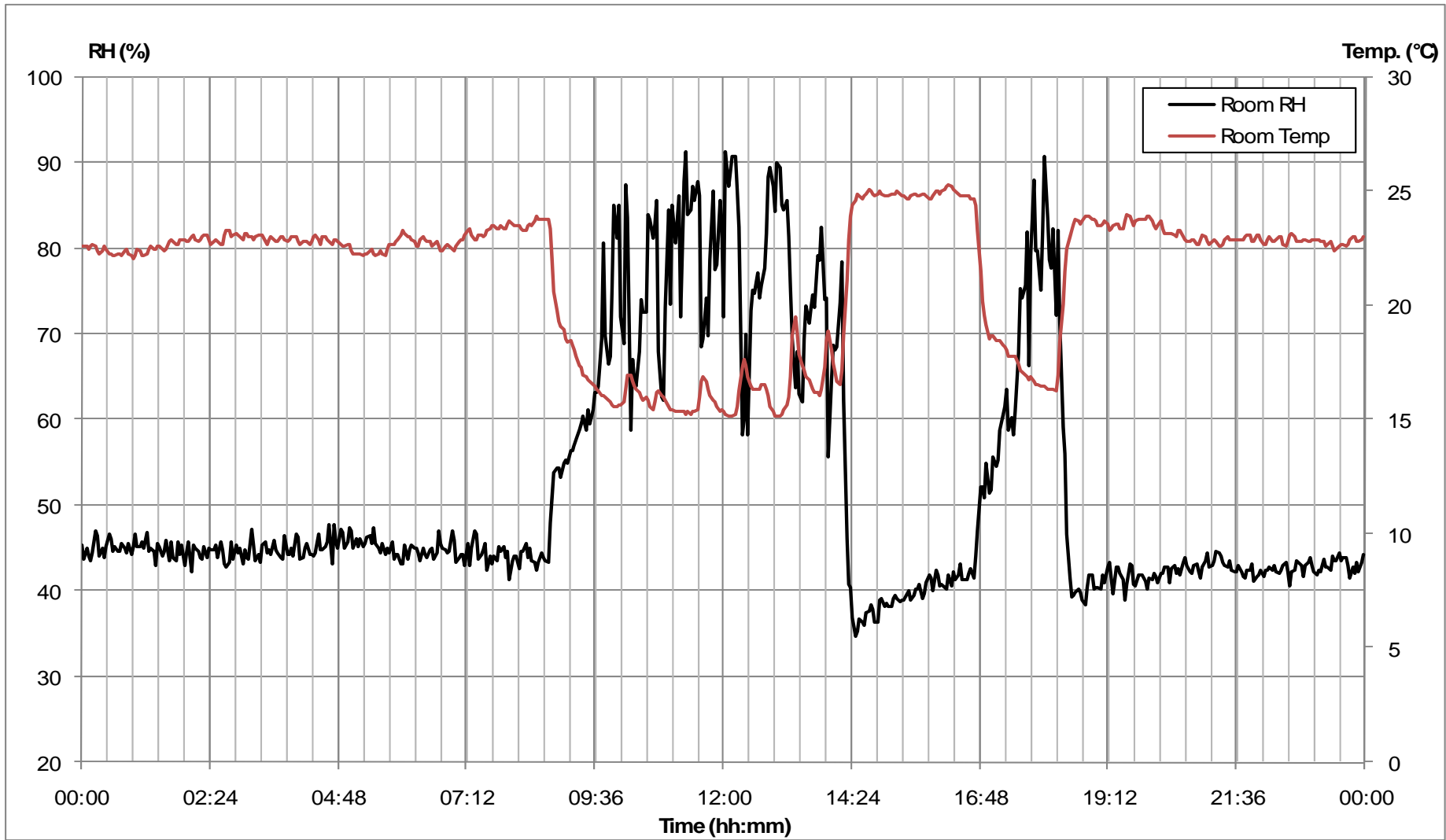

Figure 9.42. Relative humidity values of room and supply air on October 27th

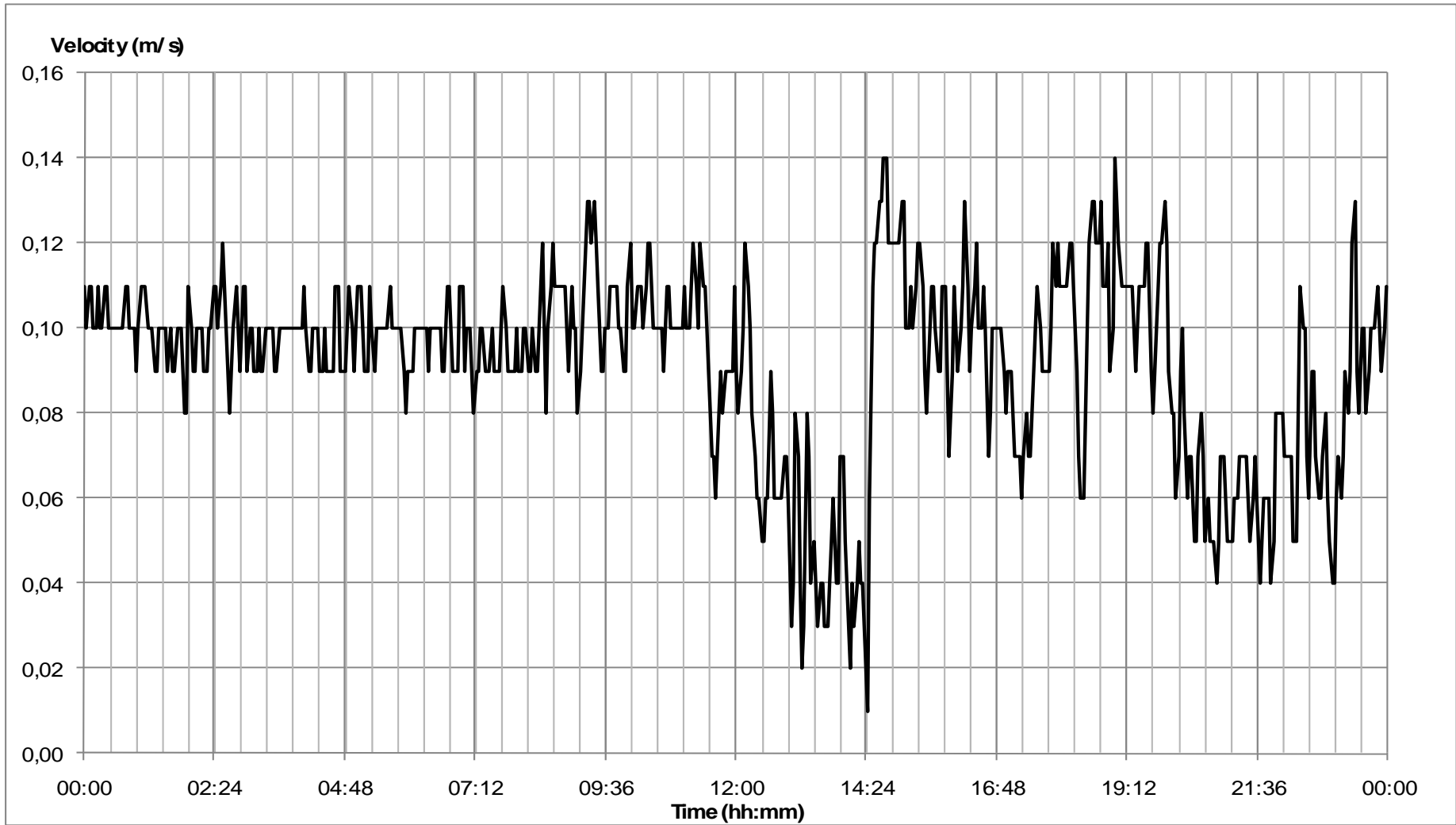

Figure 9.43. Air velocity in the operating room, October 27<sup>th</sup>

It is very difficult to explain the distribution of air velocity in the diagram (Figure 9.43). The air velocity change is seemed independent from the temperature, relative humidity, and number of occupants. The errors occurred during the measuring of low velocity of the air in the operating room may be the cause of this wrong distribution.

The distributions of particle numbers with sizes of 0.3, 0.5, 1.0 and 5.0 microns during the day are shown in Figures from 9.44 to 9.47. The intense occupancy of the operating room on this day can be seen from the particle concentration diagrams, especially when they are compared with the particle concentration of the operating room at rest. The number of the particles during the cardiovascular surgery is higher compared to the other operations in this room. The reason of this high particle concentration is the number of personnel in the operating room. Number of personnel during the cardiovascular surgery is around 10, which is two times greater than the number of personnel during plastic, urology and general surgery. Similar to the distribution of particle concentration of previous operations number of particles for 0.3 micron sized particles is considerably greater than other particles sizes. Particle concentration is around zero at nights when the operating room is at rest.

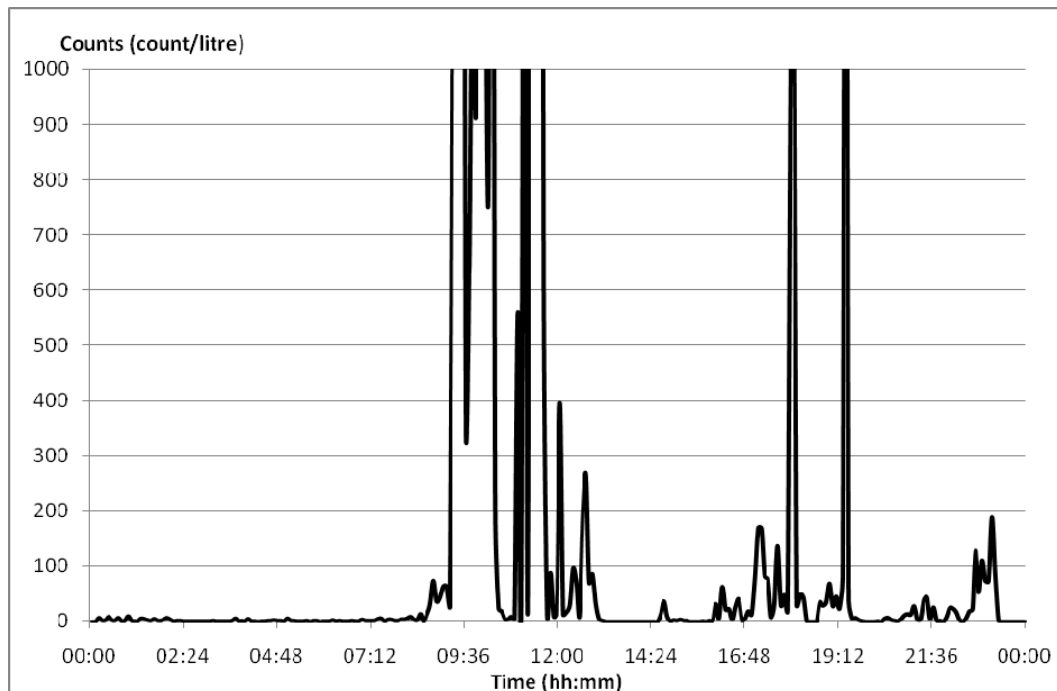

Figure 9.44. 0.3 micron particle count, October 27<sup>th</sup> (counts/liter)

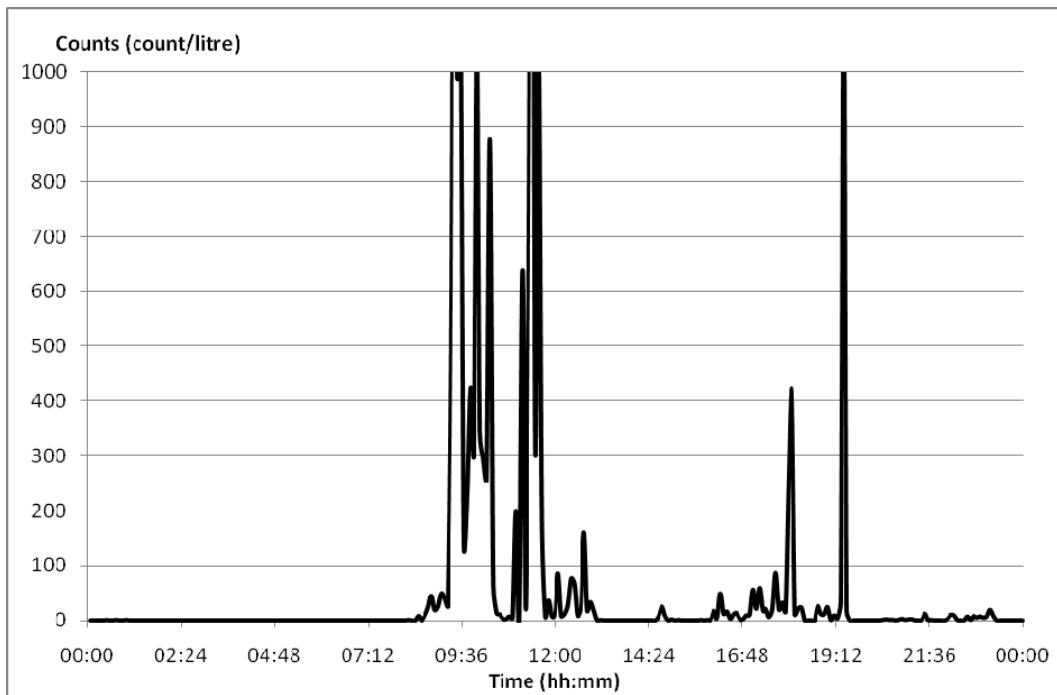

Figure 9.45. 0.5 micron particle count, October 27<sup>th</sup> (counts/liter)

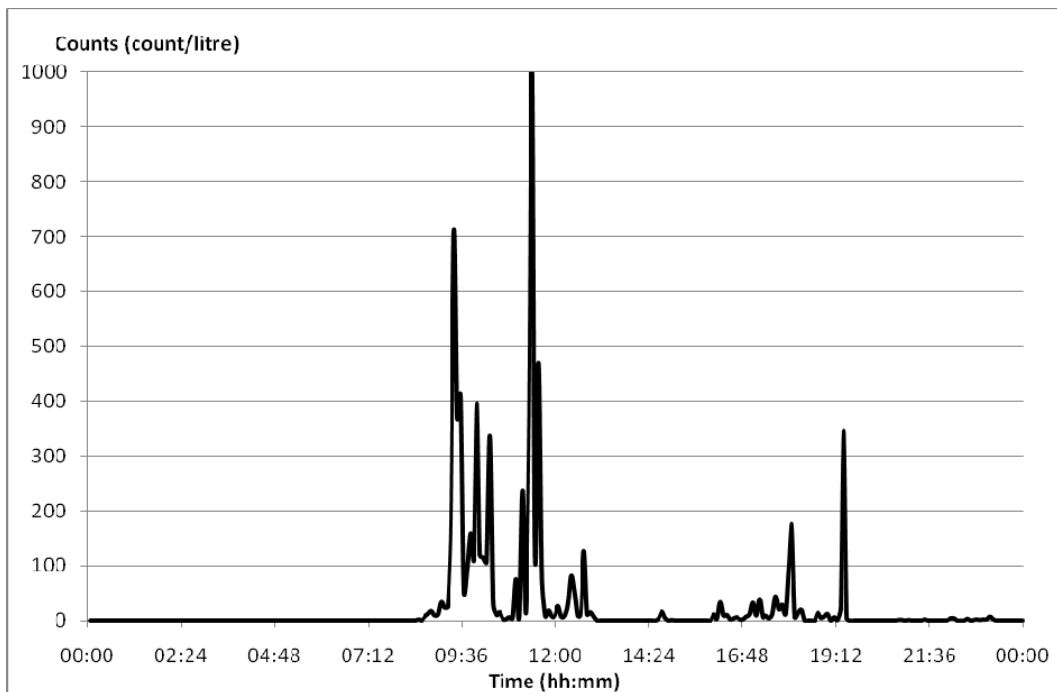

Figure 9.46. 1.0 micron particle count, October 27<sup>th</sup> (counts/liter)

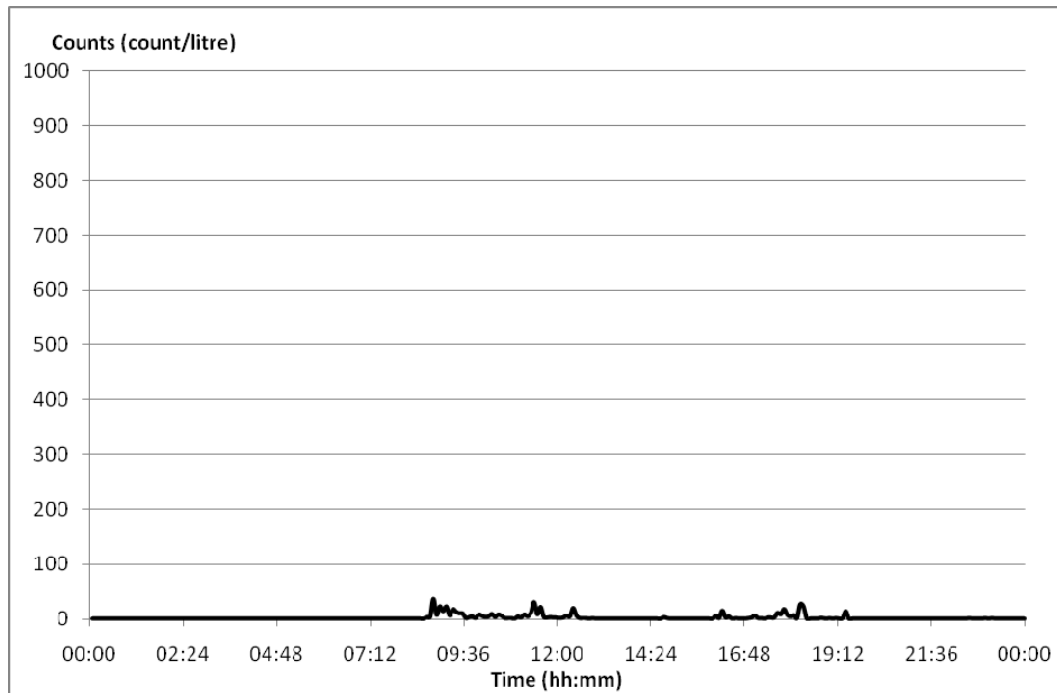

Figure 9.47. 5.0 micron particle count, October 27<sup>th</sup> (counts/liter)

### 9.5.5. October 28<sup>th</sup>

28<sup>th</sup> October is the last day of measurements in the operating room. The measurements were conducted until 18.00 in the evening. After this hour, the devices were moved to sterile corridor to have an idea about the temperature, relative humidity and particle concentration in space out of the operating room.

On this day, as seen from Table 9.1, a general surgery operation was started at 10.30 and ended at 16.30. The change of the temperature in the operating room during this time is shown in Figure 9.48. The operating room temperature was around 23°C during the night and it was reduced to 17°C before the start of the general surgery. The temperature of the room was maintained around 16°C during the operation and then, it was increased to 24°C.

As seen from the relative humidity data in Figure 9.49, the relative humidity level of the room is kept at 45% during night as the previous days and up to the beginning of the operation. The relative humidity level increases with the decrease of the room temperature. At the end of the surgery, a sudden decrease in relative humidity level is observed and this was based on the sudden increase in the room temperature.

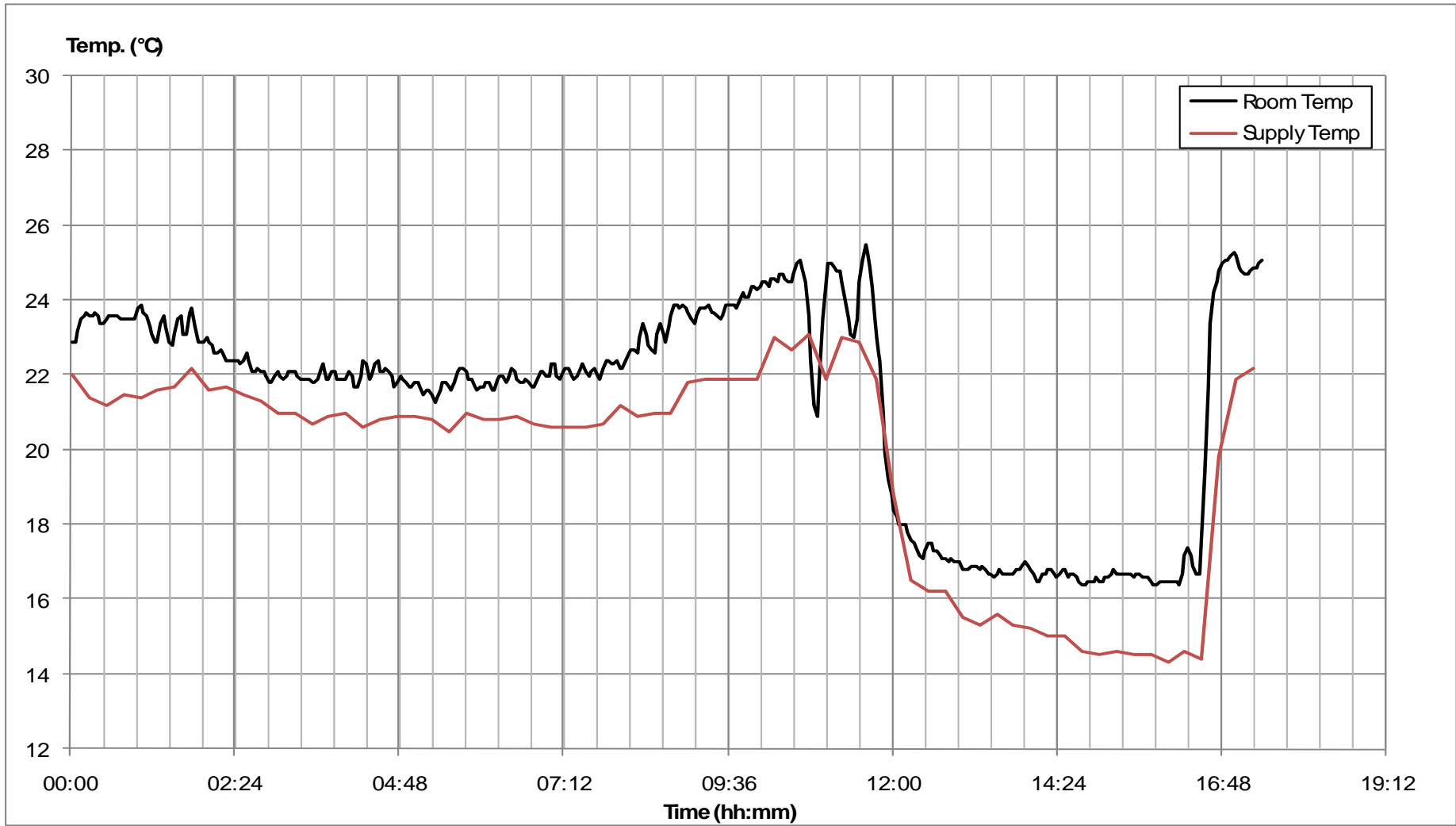

Figure 9.48. Room and supply air temperature values of operating room on October, 28<sup>th</sup>

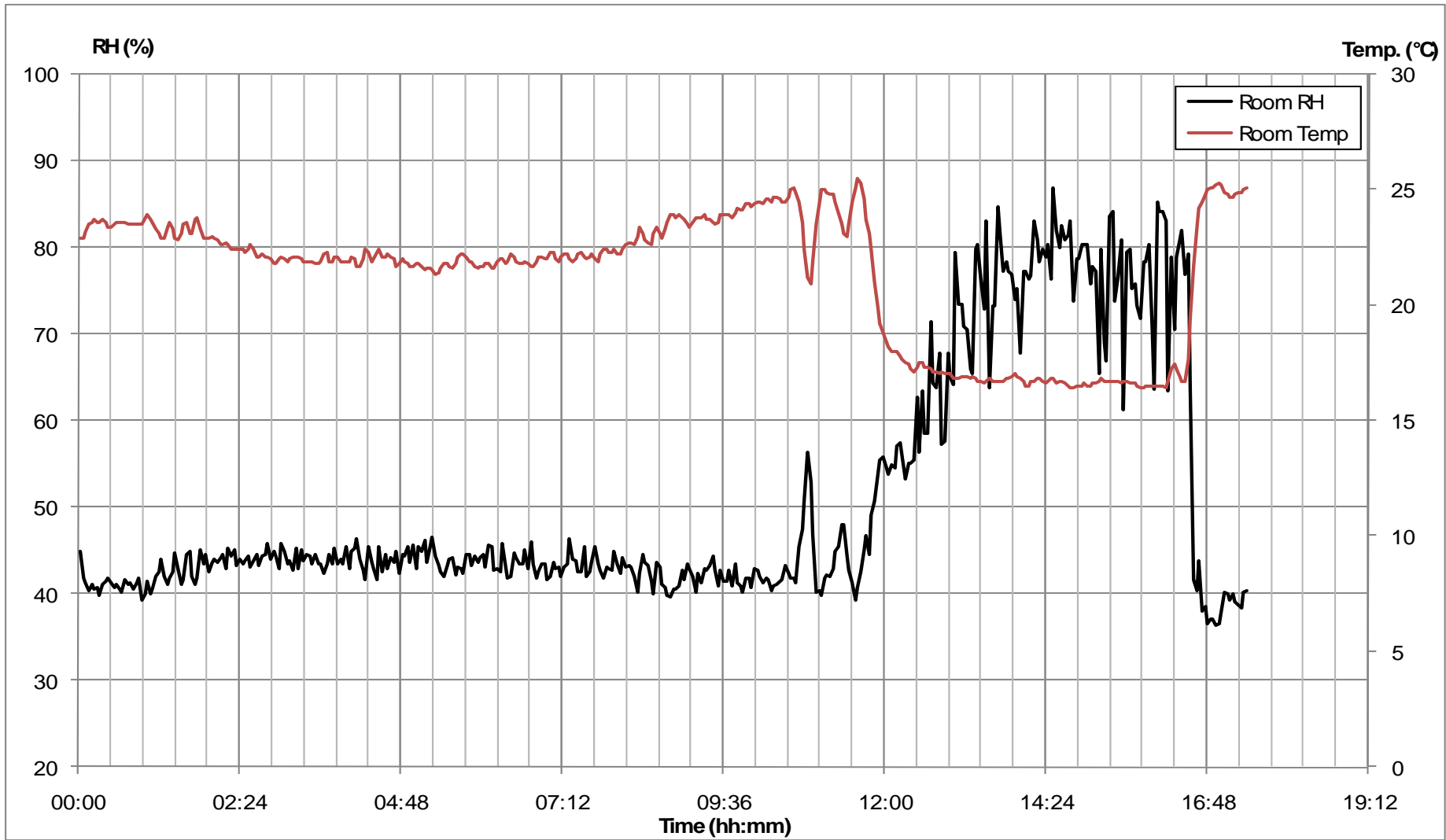

Figure 9.49. Relative humidity values of room and supply air on October 28<sup>th</sup>

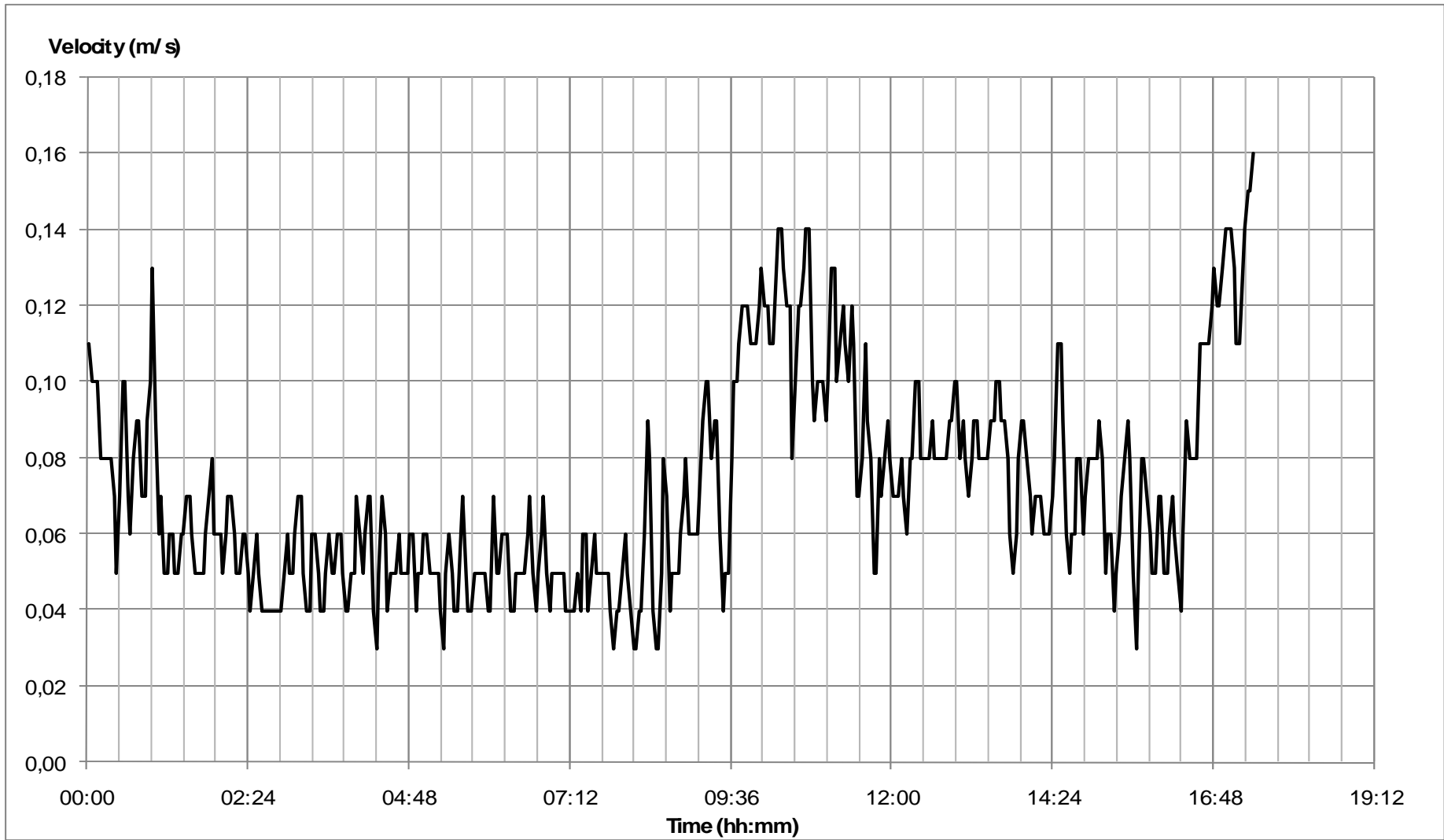

Figure 9.50. Air velocity in the operating room, October 28<sup>th</sup>



It is difficult to get a conclusion about the distribution of air velocity in Figure 9.50 due to measurement errors.

The change of the particle concentration during the period is presented in Figures from 9.51 to 9.54. The concentration of the particles for all sizes increases with the start of the operation and it is almost zero during the remaining period. It is also seen that the maximum numbers of particles are lower than the peak values of the busiest day, 27<sup>th</sup> October.

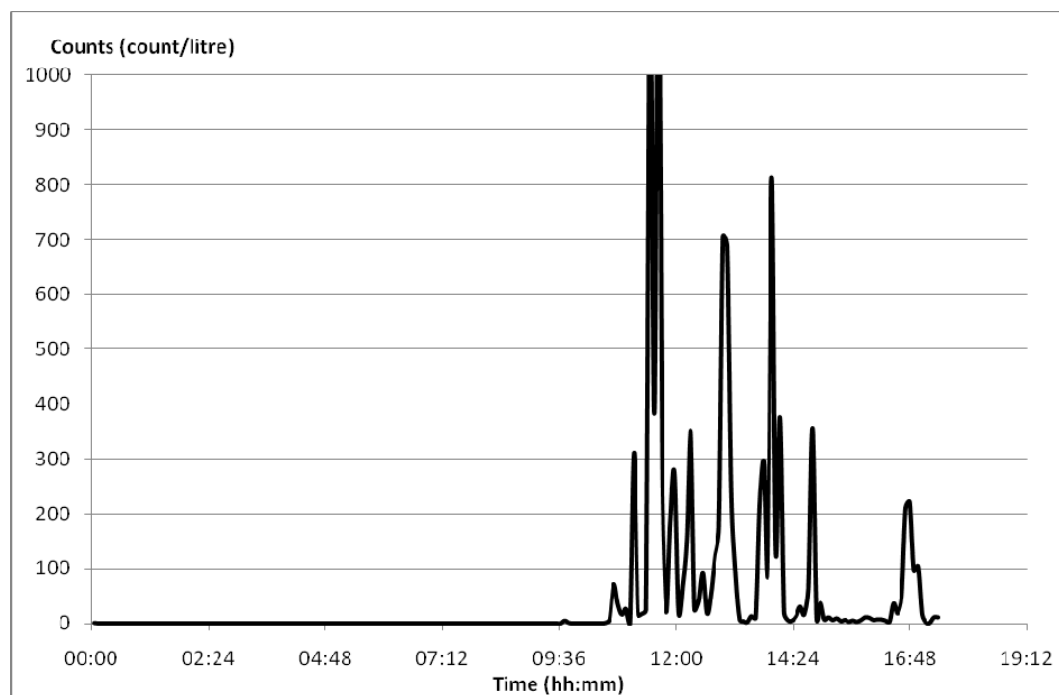

Figure 9.51. 0.3 micron particle count, October 28<sup>th</sup> (counts/liter)

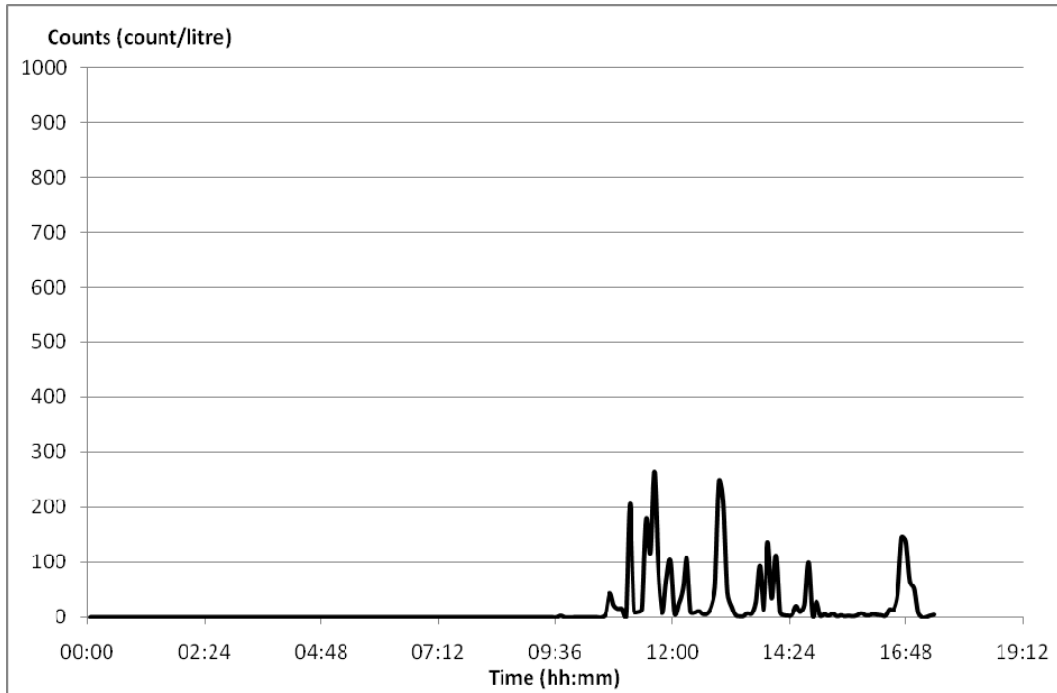

Figure 9.52. 0.5 micron particle count, October 28<sup>th</sup> (counts/liter)

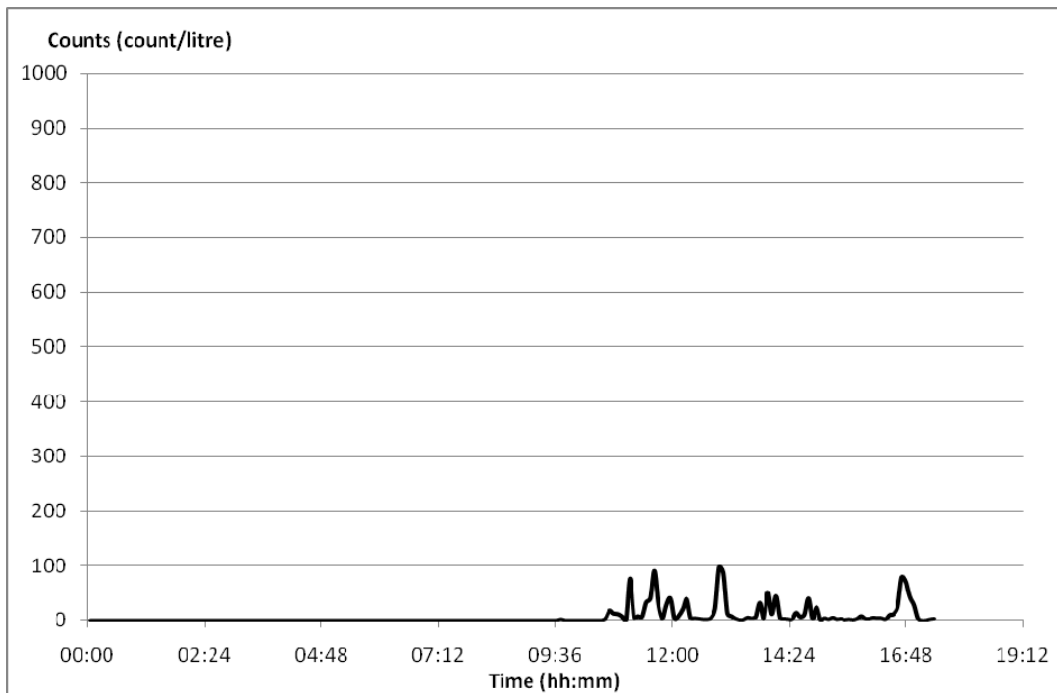

Figure 9.53. 1.0 micron particle count, October 28<sup>th</sup> (counts/liter)

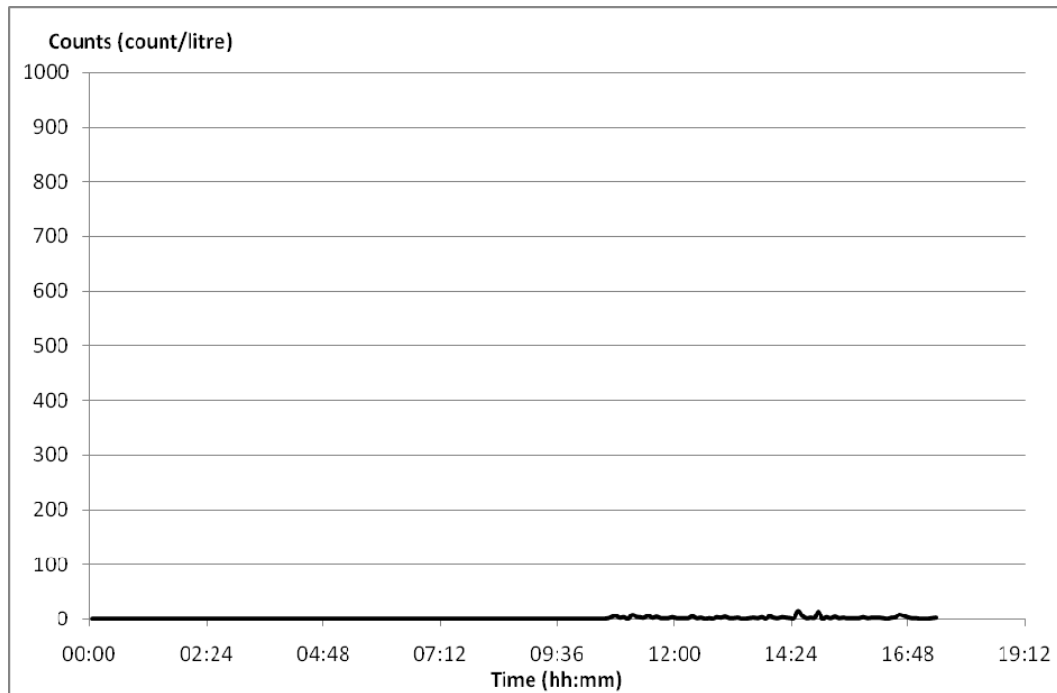

Figure 9.54. 5.0 micron particle count, October 28<sup>th</sup> (counts/liter)

### 9.5.6. October 29<sup>th</sup> and 30<sup>th</sup> Sterile Corridor

After the completion of the measurements in the operating room, the devices were set up for the same measurements to be completed in the sterile corridor of the operating suite. Unfortunately there had been a technical problem with the INNOVA 7710 software. Because of this reason, temperature and relative humidity of the sterile corridor and also the air velocity in the corridor could not be measured. However, the particle concentration in sterile corridor is measured for 29<sup>th</sup> and 30<sup>th</sup> October. The collected particle count data for these days are given in Figures from 9.55 to 9.62.

The 0.3 and 0.5 micron sized particle concentration for 29<sup>th</sup> October is given in Figure 9.55 and 9.56. As seen from these figures, the number of 0.3 and 0.5 micron sized particles is as high as the concentration in the operating room while it is “in operation”. It can be added that the time interval in which the concentration of particles are high is wider than the operating room. This wider time interval is all the time the sterile corridor is heavily occupied. In other words, the concentration of 0.3 micron sized particles is high during the all period that the sterile corridor is in use. Moreover, this particle concentration reduces to almost zero at night, when the occupation of the sterile corridor is at its minimum, but it is not as low as the operating room.

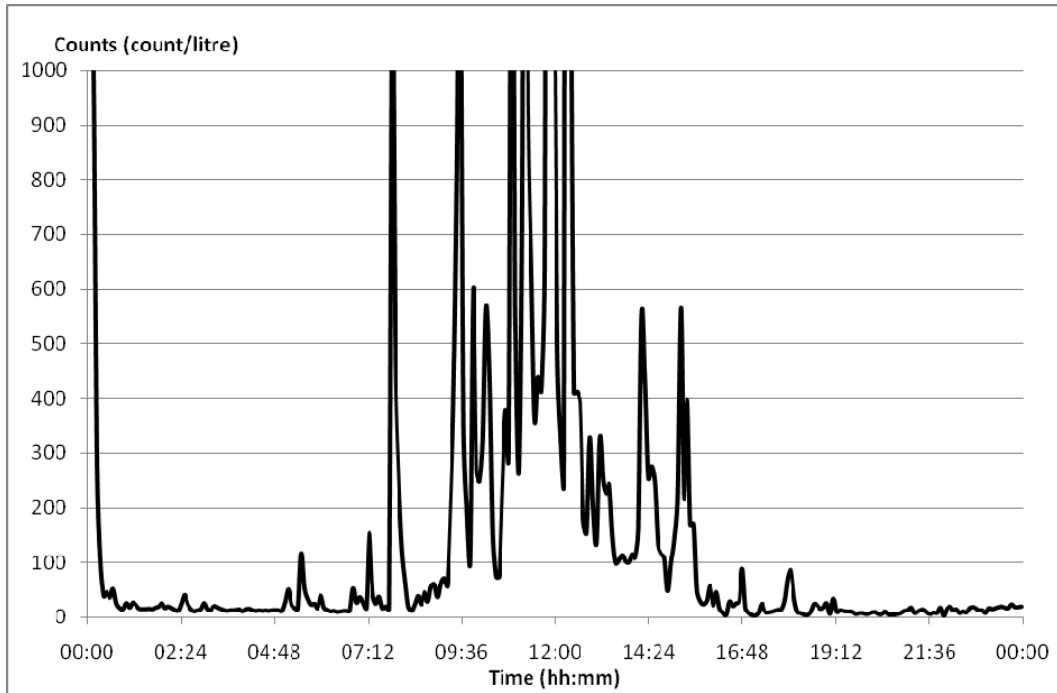

Figure 9.55. 0.3 micron particle count in sterile corridor, October 29<sup>th</sup> (counts/liter)

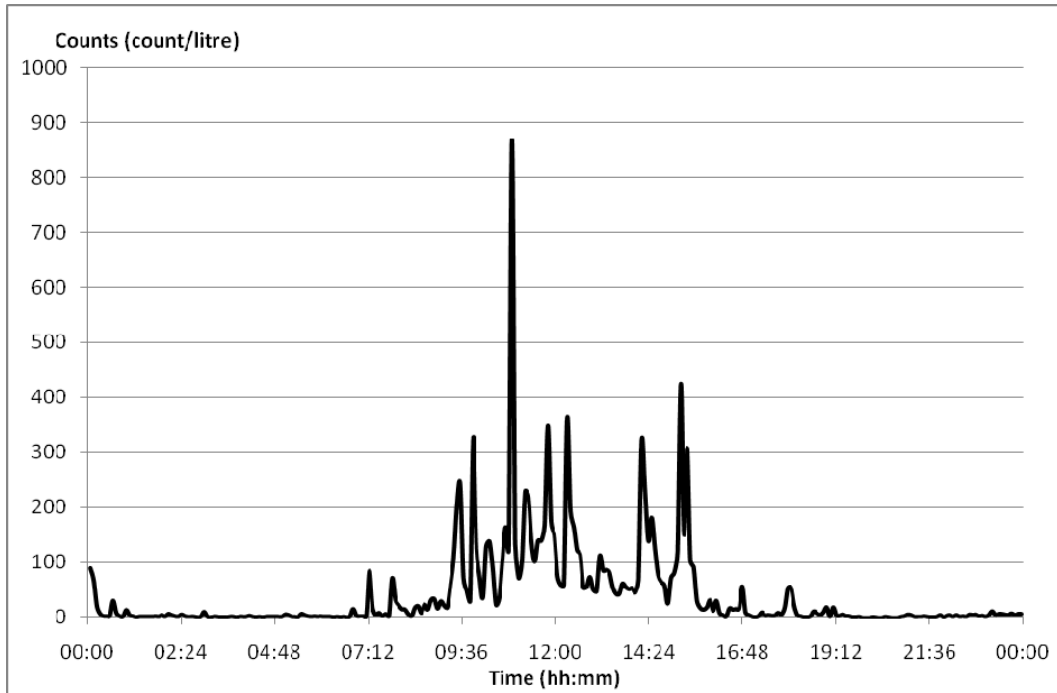

Figure 9.56. 0.5 micron particle count in sterile corridor, October 29<sup>th</sup> (counts/liter)

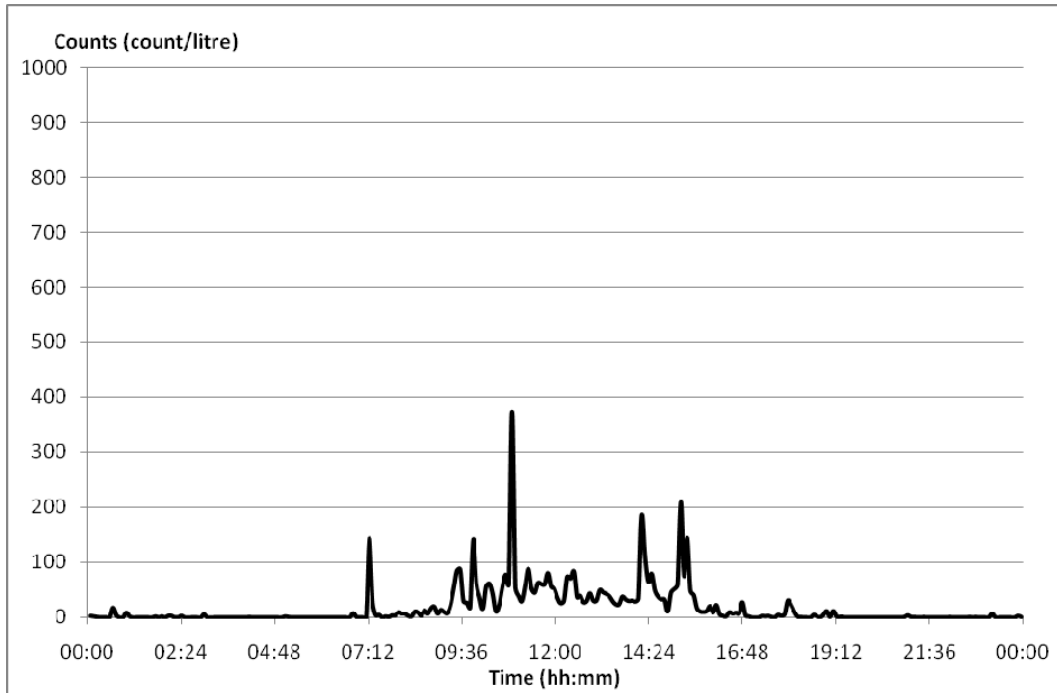

Figure 9.57. 1.0 micron particle count in sterile corridor, October 29<sup>th</sup> (counts/liter)

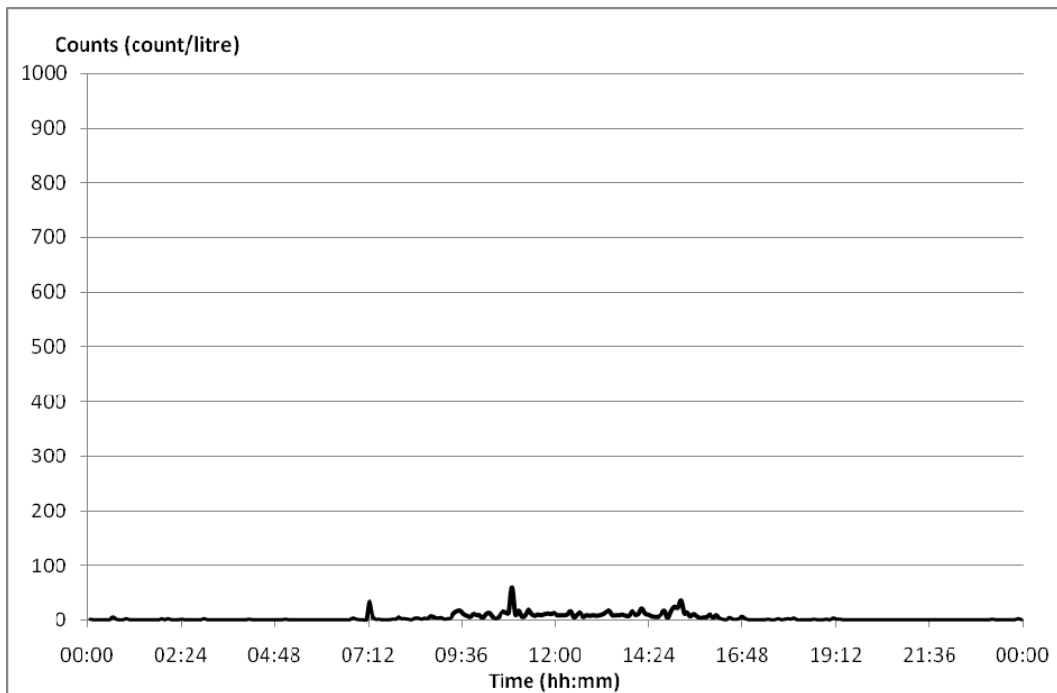

Figure 9.58. 5.0 micron particle count in sterile corridor, October 29<sup>th</sup> (counts/liter)

The concentration of 1.0 and 5.0 micron sized particles are lower than the 0.3 and 0.5 micron sizes as expected. The maximum count of 1.0 micron particles is lower than the observed peak concentrations of this particle size in operating room. The reason of this may be the occupational intensity of the operating rooms, which, in certain operations, up to 10 persons work in an operating room. Especially when the movement in the operating room is high, the particle concentration had got much higher than the concentration of sterile corridor.

The particle count distribution for 30<sup>th</sup> October is given in Figures 9.59 to 9.61. The same particle concentration distribution is observed on this day. The range that the particle concentration is high is distributed to all day, and the maximum counts of any particle size are lower than the observed maxima in the operating room and this difference probably depends on the occupational intensity, again.

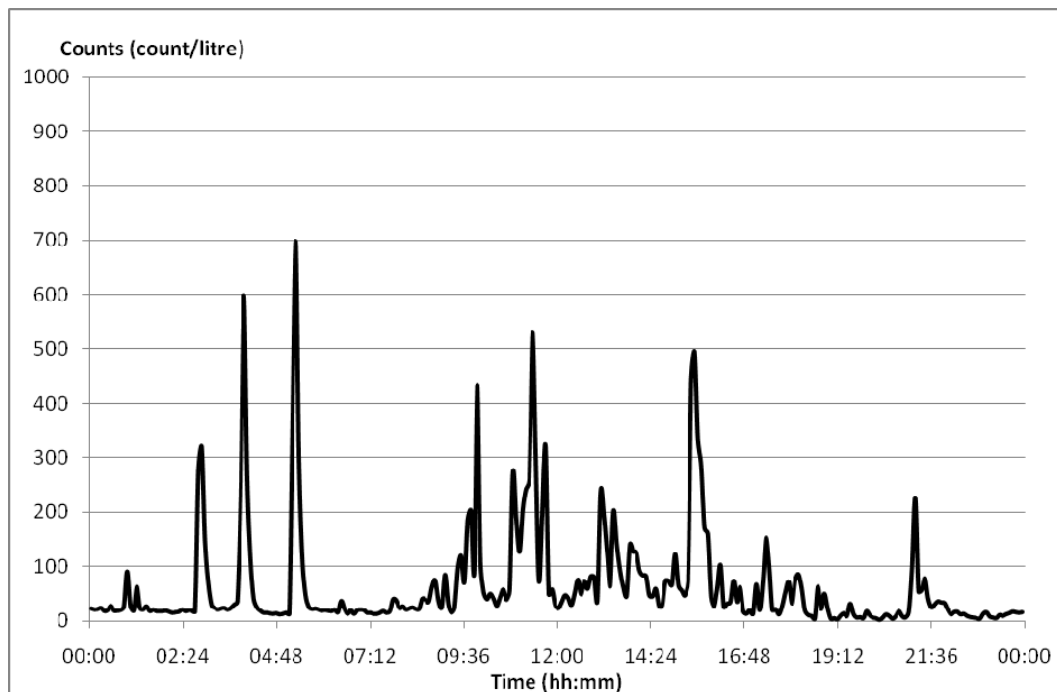

Figure 9.59. 0.3 micron particle count in sterile corridor, October 30<sup>th</sup> (counts/liter)

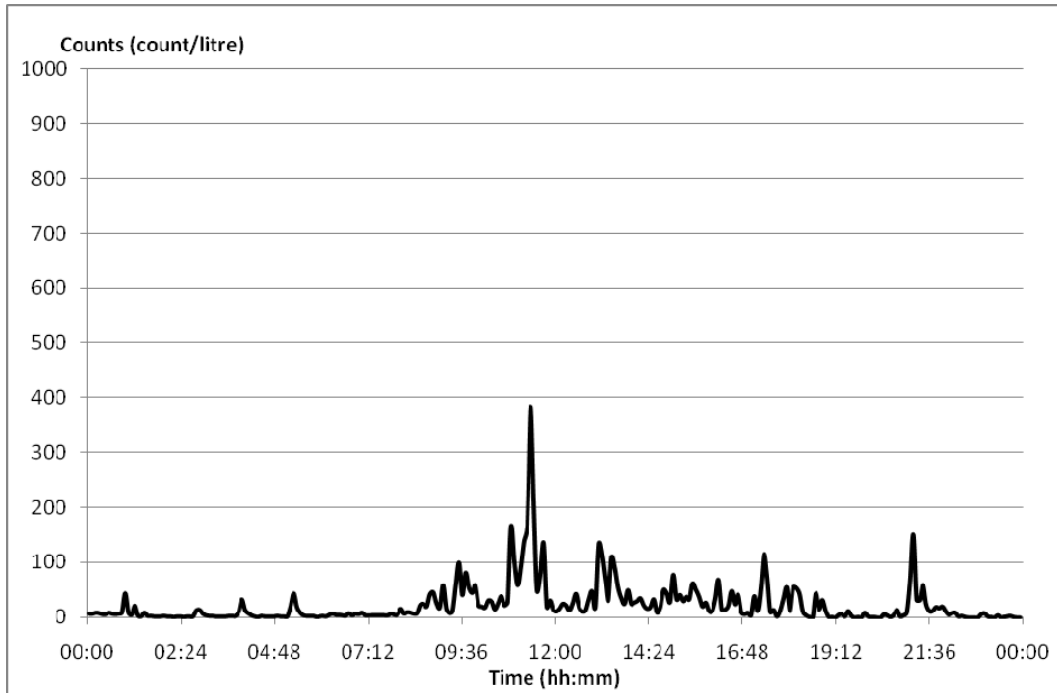

Figure 9.60. 0.5 micron particle count in sterile corridor, October 30<sup>th</sup> (counts/liter)

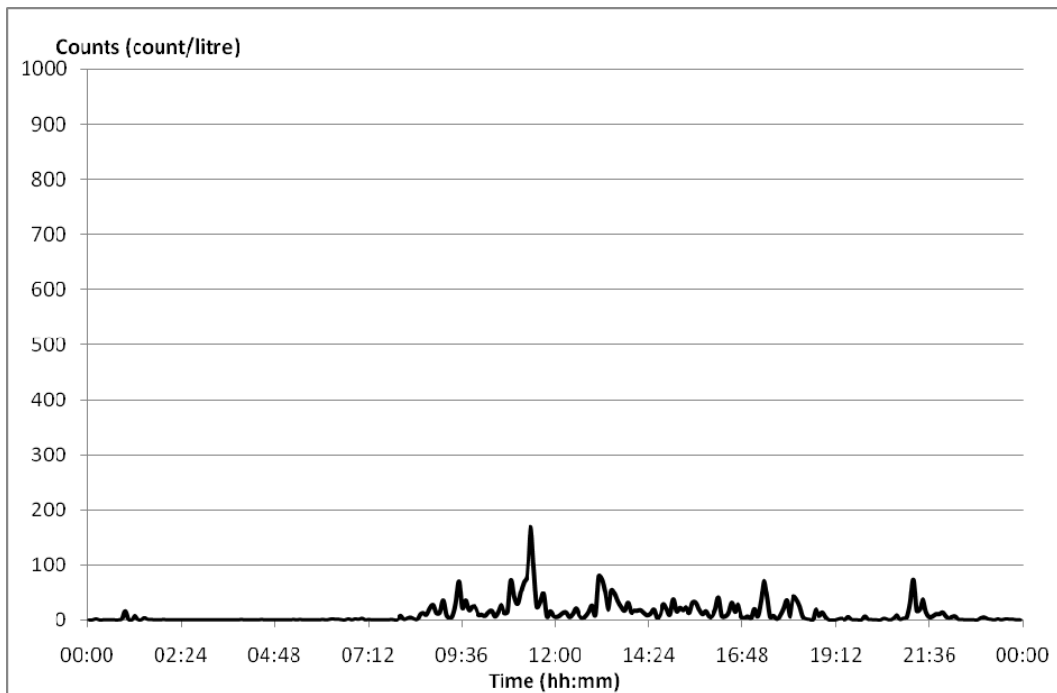

Figure 9.61. 1.0 micron particle count in sterile corridor, October 30<sup>th</sup> (counts/liter)

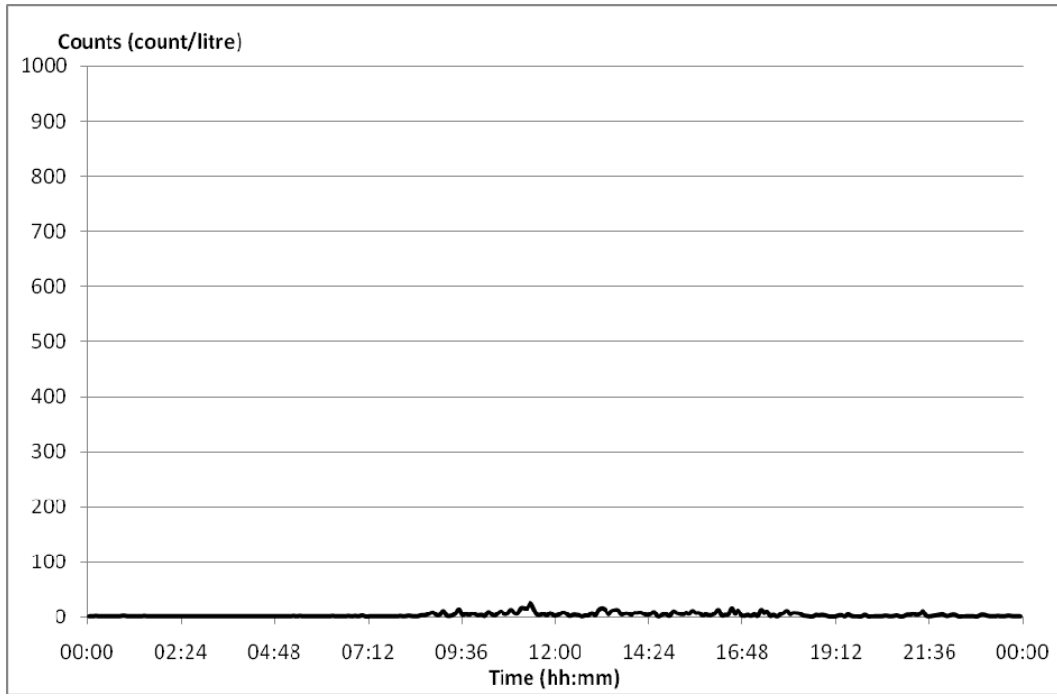

Figure 9.62. 5.0 micron particle count in sterile corridor, October 30<sup>th</sup> (counts/liter)



## CHAPTER 10

### CONCLUSION

In this study the design parameters for HVAC systems serving to sterile spaces in hospitals have been investigated. Brief information about the sterile spaces in a hospital was given. The history of the sterile HVAC applications in hospitals was explained. Moreover, a detailed literature survey on effects of HVAC design parameters on infection control was performed.

Three standards and guidelines (DIN 1946-4, ASHRAE and VDI 2167) are globally accepted while remaining references are national standards and regulations. The comparison of these references revealed the following results;

- It is seen that the temperature, relative humidity, particle and microorganism concentrations, air velocity and distribution, pressurization of the spaces, total and fresh air change rates all play important roles on infection transmission control. They have important effects on the success of the operation or survival of a premature newborn, etc. The mentioned design parameters must be controlled by a well designed, manufactured and operated HVAC system.
- Various standards and guidelines provide satisfactory information about the design parameters of operating room, however; no detailed information about the design parameters of other spaces requiring sterile conditions could be found.
- The most concrete distinguish between the spaces of a hospital according to their need of hygiene was performed by DIN 1946-4 as Class I and II spaces referring to high or very high levels of hygiene needs and normal levels of hygiene needs, respectively.
- No sufficient information about the filtration stages for sterile environments could be found in most of the studied references. Furthermore, no agreement exists on the method for measuring hygiene levels.

- DIN 1946-4 and VDI 2167 were found to be stricter for specifying the values of the design parameters than the rest of the reviewed references. Generally, guidelines give general information about the design parameters with some examples of application. The given information is not sufficient for a designer and he should decide about the system based on his experience.
- The air flow between sterile spaces was found to be an important factor to keep the required hygiene levels. In accordance with this, it was seen that all of the standards and guidelines pay special attention to this issue. Although the required air flow directions between the sterile rooms are defined, no fixed relative pressure value or method for providing pressure difference between spaces is specified by the most of the reviewed references.
- The air velocity and distribution of air in a sterile space, except for operating rooms, are not clearly specified by the most of the references; however it is seen that these parameters have an important role on the transfer of airborne infectious organisms.
- Despite the fact that some of the reviewed standards are accepted around the world, some information given by these references are in conflict with each other. This study shows that a large lack of information exists on the design parameters of HVAC systems serving to sterile areas of hospitals. Despite the well known effects of HVAC systems on infection transmission, it is seen that no union standard exists. Hence, further studies on specification of the design parameters for sterile spaces have to be performed. Cooperation between countries and reducing the number of standards and guidelines on this field can accelerate the studies.

In the performed experimental study continuous measurement were achieved from an operating room and a sterile corridor of an operating suite. These measurements were conducted “in operation” condition of the hospital. The purpose was to understand if the installed systems were functioning as desired. The measurements was continued for 6 full days in the operating room and 2 full days in the sterile corridor. The obtained results from the experimental study are summarized as follows:

- As mentioned by some of the references, it was seen that the required room condition depends on the surgical procedure.

- Although there are recommended design room temperature values for the HVAC systems serving to operating rooms by the references, the demand of the medical staff, especially for cardiovascular procedures, were beyond these recommendations. This shows the lack of information of the current standards and guidelines. It is seen that the designer must not decide about the capacity of the HVAC system without holding a meeting with the medical staff of the hospital.
- The activity and movement of personnel in the clean area greatly increases the particle concentrations in the air. It should be mentioned that the measurements were performed out of the laminar flow area hence the measured particle concentrations are greater than particle concentration under the laminar flow unit. Since the laminar flow provided a sweep of particles from the operating room table to the exhaust registers, it was normal to have high particle concentrations.
- The particle removal efficiency of the system is high, because the number of the particles can quickly drop, after a high generation of particle in the room.
- The measurements showed that the relative humidity of the room was changed in accordance with the room temperature. The value of 50% relative humidity can be achieved when the room temperature is 24°C. Since the room temperature highly fluctuates, the relative humidity also varies correspondingly.
- It is difficult to comment on the results of the air velocity measurements since the air movement in the room was slow and the movement of personnel affected the measurement greatly. But generally the velocity of air was below 10 m/s. The fluctuations of air velocity during the night was also not been understood since there was no personnel in the room.
- It was also seen that the sterile corridor is as clean as the operating room in terms of particle concentration. Turbulent air distribution was implemented in this area. This reveals that turbulent air distribution systems can be as effective as laminar flow systems, if the system is properly designed and constructed.

The performed study showed that there are many standards and guidelines in this field but even the widely accepted references do not involve detailed information for

designers. This lack of information increases the importance of the expertise of the designer. The conducted experimental study also showed the importance of the communication between the mechanical systems designer and the medical staff, since the references are not sufficient for designers.

## REFERENCES

- AAF International. 2008. *HEPA Filtration Astro Cell I Series Metal Sides: AAF International*.  
<http://www.aafintl.com/Products/HEPA%20Filtration/Filters/AstroCel%20I/AstroCel%20I/Metal%20Sides%20Non%20Scanned.aspx> (accessed November 14, 2008).
- American Institute of Architects. 2006. *Guidelines for Design and Construction of Health Care Facilities*. Washington: American Institute of Architects.
- American Society of Heating Refrigerating and Air-Conditioning Engineers. 2003. *HVAC Design Manual for Hospitals and Clinics*. Atlanta: American Society of Heating Refrigerating and Air-Conditioning Engineers, Inc.
- ANIL, Orkun Baki, Moghtada Mobedi, and M Barış Özerdem. 2007. "Hastane Hijyenik Ortamlarının Klima ve Havalandırma Sistemleri." 8. *Ulusal Tesisat Mühendisliği Kongresi (8th National Heating, Ventilation, Air-Conditioning and Sanitary Engineering Conference and Exhibition)*. İzmir: Chamber of Mechanical Engineers:513-525.
- Balaras, Constantinos A, Elena Dascalaki, and Athina Gaglia. 2007. "HVAC and Indoor Thermal Conditions in Hospital Operating Rooms." *Energy and Buildings* 39:454-470.
- Bilge, Mustafa. 2007. "Ameliyathane ve Yoğun Bakım Ünitelerinde Devreye Alma, Test, Ölçüm ve Ayar (Commissioning) Çalışmaları." 8. *Ulusal Tesisat Mühendisliği Kongresi (8th National Heating, Ventilation, Air-Conditioning and Sanitary Engineering Conference and Exhibition)*. İzmir: Chamber of Mechanical Engineers:727-730.
- Chow, T T, and X Y Yang. 2005. "Ventilation Performance in the Operating Theatre Against Airborne Infection: Numerical Study on an Ultra-clean System." *Journal of Hospital Infection* 59:138-147.
- Climet Instruments. 2005. *CI-450 Laser Particle Counter Operator's Manual*. Redlands: Climet Instruments.
- Climet Instruments Company. 2007. "Climet Instruments Company - Products." *Climet Instruments Company*. [http://www.climet.com/Prod\\_CI-450t.html](http://www.climet.com/Prod_CI-450t.html) (accessed September 4, 2008).
- Cumberland Health Care Foundation. 2007. "The Hospital Facility: Cumberland Health Care Foundation." *Cumberland Health Care Foundation Web site*. <http://www.chcfoundation.com/hospital.html> (accessed November 6, 2008).

- Deutsches Institut für Normung. 1999. *DIN 1946-4 Ventilation and Air Conditioning - Part 4: Ventilation in Hospitals*. Berlin: Deutsches Institut für Normung e.V.
- Dharan, S, and D Pittet. 2002. "Environmental Controls in Operating Theatres." *Journal of Hospital Infection* 51:79-84.
- Dorchies, Fabrice. 2005. "Nosocomial Infections and Air Filtration in Operating Theatre Suites - Application of French Standard NFS90-351:2003." *Business Briefing: Hospital Engineering & Facilities Management*:1-3.
- East Oregon Surgery Center. 2003. "Virtual Tour of the EOSC." *East Oregon Surgery Center*. [http://www.eastoregonsurgerycenter.com/facilities\\_pages/pre\\_op.htm](http://www.eastoregonsurgerycenter.com/facilities_pages/pre_op.htm) (accessed November 3, 2008).
- Halton Group. 2008. "HFB Airflow Management Damper Technical Data Sheet." *Halton Group Web site*. [http://www.halton.com/halton/cms.nsf/files/485B884C41FDEF65C2257460001CE38F/\\$file/hfb\\_en062008.pdf](http://www.halton.com/halton/cms.nsf/files/485B884C41FDEF65C2257460001CE38F/$file/hfb_en062008.pdf) (accessed November 12, 2008).
- Halton Group. 2008. "Products: Halton Group." *Halton Group Web site*. [http://www.halton.com/halton/images.nsf/files/A3CDF78DC50DA98FC22571D9005EE66F/\\$file/airflow\\_dampers\\_EN.pdf](http://www.halton.com/halton/images.nsf/files/A3CDF78DC50DA98FC22571D9005EE66F/$file/airflow_dampers_EN.pdf) (accessed November 12, 2008).
- Health Department of Western Australia Facilities & Assets Branch. 1999. *Private Hospital Guidelines - Guidelines for the Construction, Establishment and Maintenance of Private Hospital and Day Procedure Facilities*. East Perth: Health Department of Western Australia.
- Heperkan, Hasan. 2007. "Temiz Oda Klima Sistemlerinde Devreye Alma, Dengeleme, IQ ve OQ Testleri, Ölçüm ve Belgelendirme." 8. *Ulusal Tesisat Mühendisliği Kongresi (8th National Heating, Ventilation, Air-Conditioning and Sanitary Engineering Conference and Exhibition)*. İzmir: Chamber of Mechanical Engineers:739-750.
- Humphreys, H, and E W Taylor. 2002. "Operating Theatre Ventilation Standards and the Risk of Postoperative Infection." *Journal of Hospital Infection* 50:85-90.
- JSP Health Network. 2003. "Virtual Tour: JSP Health Network." *JSP Health Network Web site*. <http://www.jpshhealthnet.org/provider-opportunities/virtual-tour.aspx> (accessed November 6, 2008).
- Kenter, Metin. 2007. "Temiz Oda Tasarımı ve İklimlendirme Sisteminin Temiz Odalarda Önemi." 8. *Ulusal Tesisat Mühendisliği Kongresi (8th National Heating, Ventilation, Air-Conditioning and Sanitary Engineering Conference and Exhibition)*. İzmir: Chamber of Mechanical Engineers:529-544.

- Landrin, A, A Bissery, and G Kac. 2005. "Monitoring Air Sampling in Operating Theatres: Can Particle Counting Replace Microbiological Sampling?" *Journal of Hospital Infection* 61:27-29.
- LumaSense Technologies A/S. 2005. "INNOVA 1221 Product Data Sheet." *LumaSense Technologies A/S Web site*. [http://www.lumasense.dk/uploads/media/PD-1221\\_BP1525-16.pdf](http://www.lumasense.dk/uploads/media/PD-1221_BP1525-16.pdf) (accessed November 12, 2008).
- LumaSense Technologies A/S. 2005. "MM0034 Product Data Sheet." *LumaSense Technologies A/S Web site*.  
[http://www.lumasense.dk/fileadmin/Files/Product\\_data/PD\\_MM0034.pdf](http://www.lumasense.dk/fileadmin/Files/Product_data/PD_MM0034.pdf)  
(accessed November 12, 2008).
- LumaSense Technologies A/S. 2005. "MM0037 Product Data Sheet." *LumaSense Technologies A/S Web site*.  
[http://www.lumasense.dk/fileadmin/Files/Product\\_data/PD\\_MM0037.pdf](http://www.lumasense.dk/fileadmin/Files/Product_data/PD_MM0037.pdf)  
(accessed November 12, 2008).
- LumaSense Technologies A/S. 2005. "MM0038 Transducer Product Data Sheet." *LumaSense Technologies A/S Website*.  
[http://www.lumasense.dk/fileadmin/Files/Product\\_data/PD\\_MM0038.pdf](http://www.lumasense.dk/fileadmin/Files/Product_data/PD_MM0038.pdf)  
(accessed November 12, 2008).
- LumaSense Technologies A/S. 2005. "Thermal Comfort Data Logger." *LumaSense Technologies A/S Web site*.  
[http://www.lumasense.dk/Thermal\\_Comfort.indoor\\_climate.0.html](http://www.lumasense.dk/Thermal_Comfort.indoor_climate.0.html) (accessed September 9, 2008).
- Mechanical Products Intermountain. 2008. *Mechanical Products Intermountain website*.  
<http://www.mp-int.com/documents/41.htm> (accessed November 14, 2008).
- Melhado, Monica A, Jan H M Hensen, and Marcel Loomans. 2006. "Literature Review of Staff Thermal Comfort and Patient "Thermal Risks" in Operating Rooms." *8th International Healthy Buildings Conference*. Lisbon:11-14.
- Melhado, Monica A, Jan H M Hensen and Marcel Loomans. 2006. "Review of Ventilation Systems in Operating Rooms in View of Infection Control." *6th International Postgraduate Research Conference in the Built and Human Environment*:478-487.
- Melhado, Monica A, Jan H M Hensen, Marcel Loomans, and Lubos Forejt. 2005. "Review of Operating Room Ventilation Standards." *17th International Air-Conditioning and Ventilation Conference*.
- Neil, Janice A, Pamela F Nye, and Lisa Ann Toven. 2005. "Environmental Surveillance in the Operating Room." *AORN Journal* 82:43-49.

- Owers, K, E James, and G Bannister. 2004. "Source of Bacterial Shedding in Laminar Flow Theatres." *Journal of Hospital Infection*:230-232.
- Özcan, Filiz. 2007. "İlaç Fabrikasında HVAC Validasyon Çalışmaları Hakkında Genel Değerlendirme." 8. *Ulusal Tesisat Mühendisliği Kongresi (8th National Heating, Ventilation, Air-Conditioning and Sanitary Engineering Conference and Exhibition)*. İzmir: Chamber of Mechanical Engineers:733-735.
- Queensland Health Communicable Diseases Unit & Capital Works Branch. 2002. *Capital Works Guidelines Building and Refurbishment: Infection Control Guidelines*. Brisbane: Queensland Government.
- Smyth, E T M, H Humphreys, A Stacey, E W Taylor, P Hoffman, and G Bannister. 2005. "Survey of Operating Theatre Ventilation Facilities for Minimally Invasive Surgery in Great Britain and Northern Ireland: Current Practice and Considerations for Future." *Journal of Hospital Infection* 61:112-122.
- Stacey, A, and H. Humphreys. 2002. "A UK Historical Perspective on Operating Theatre Ventilation." *Journal of Hospital Infection* 52:77-80.
- Suzhou Industrial Park Jiatai Dust-Free Equipment Co. Ltd. 2008. *Products: Suzhou Industrial Park Jiatai Dust-Free Equipment Co. Ltd.* [http://www.jtcleanroom.com/en/enproduct.asp?sort\\_id=23&sort=Air-conditioning%20unit](http://www.jtcleanroom.com/en/enproduct.asp?sort_id=23&sort=Air-conditioning%20unit) (accessed November 9, 2008).
- Verein Deutscher Ingenieure. 2004. *VDI 2167 Building Services in Hospitals Heating, Ventilation and Air-conditioning*. Düsseldorf: Verein Deutscher Ingenieure.
- Victorian Advisory Committee on Infection Control. 2007. *Guidelines for the Classification and Design of Isolation Rooms in Health Care Facilities*. Melbourne: Victorian Government, Department of Human Services.
- WA Country Health Service. 2002. "Surgical Services - CSSD (Central Sterilising Services Department): WA Country Health Service." *Midwest and Murchison Health Region*. <http://www.mmhr.org.au/Home.asp?documentid=280> (accessed November 6, 2008).
- West Walley Hospital. 2005. "Photo Gallery: West Walley Hospital." *West Walley Hospital Web Site*. [http://www.wvhospital.com/photo\\_gallery.shtml](http://www.wvhospital.com/photo_gallery.shtml) (accessed October 20, 2008).
- Whyte, W. 2001. *Cleanroom Technology*. West Sussex: John Wiley & Sons Ltd.
- Wikipedia Contributors. 2008. *Minimally Invasive Procedure*. [http://en.wikipedia.org/w/index.php?title=Minimally\\_invasive\\_procedure&oldid=244670031](http://en.wikipedia.org/w/index.php?title=Minimally_invasive_procedure&oldid=244670031) (accessed October 20, 2008).



World Health Organization Regional Office for South-East Asia. 2002. *Guidelines on Prevention and Control of Hospital Associated Infections*. New Delhi: World Health Organization.