

**DEVELOPMENT OF A DATABASE FOR THE  
RESTITUTION PHASES OF KURŞUNLU KHAN  
IN MANİSA**

**A Thesis Submitted to  
the Graduate School of Engineering and Sciences of  
İzmir Institute of Technology  
in Partial Fulfillment of the Requirements for the Degree of**

**DOCTOR OF PHILOSOPHY**

**in Architecture**

**by  
Gamze SAYGI**

**September 2016  
İZMİR**

We approve the thesis of **Gamze SAYGI**

**Examining Committee Members:**

---

**Assoc.Prof.Dr. Mine HAMAMCIOĞLU TURAN**

Department of Architectural Restoration, Izmir Institute of Technology

---

**Prof.Dr. Yalçın ARISOY**

Department of Civil Engineering, Dokuz Eylül University

---

**Assoc.Prof.Dr. Gülnur BALLICE**

Department of Interior Architecture and Environmental Design, Yaşar University

---

**Assist.Prof.Dr. Ömür SAYGIN**

Department of City and Regional Planning, Izmir Institute of Technology

---

**Assist.Prof.Dr. S. Zeynep DOĞAN**

Department of Architecture, Izmir Institute of Technology

**02 September 2016**

---

**Assoc.Prof.Dr. Mine HAMAMCIOĞLU TURAN**

Supervisor, Department of Architectural Restoration,  
Izmir Institute of Technology

---

**Assoc.Prof.Dr. Şeniz ÇIKIŞ**

Head of the Department of Architecture

---

**Prof.Dr. Bilge KARAÇALI**

Dean of the Graduate School of  
Engineering and Sciences

## ACKNOWLEDGEMENTS

This thesis has been both a scientific and personal journey for me. An important number of people provided support for the development of the thesis, and contributed throughout different challenges.

First, I would like to express my gratitude to my advisor Assoc.Prof.Dr. Mine Hamamciođlu-Turan, for her constructive comments and continuous support not only during the development of this thesis but also along my graduate education.

Second, I am deeply indebted to Dr. Fabio Remondino, who made it possible for me to be a visiting-scholar during 2013 in 3D Optical Metrology Research Unit (3DOM) of Bruno Kessler Foundation (FBK) in Trento, Italy. During this period, I started the methodological implementation of this thesis, also thanks to Dr. Giorgio Agugiaro who, since then, has been guiding my research. I am thankful for his constructive criticism and support not only during my visiting period in 2013, but also since 2014 after he has moved to the Austrian Institute of Technology (AIT), Vienna, Austria. Finally, I am grateful to AIT for providing the IT resources to temporarily host the database and the webserver.

Furthermore, I would like to acknowledge thesis Committee Members: Assist.Prof.Dr. Ömür Saygın and Assist.Prof.Dr. S. Zeynep Dođan for their valuable comments in the progress of this thesis. Besides, I am thankful to the Jury Members Prof.Dr. Yalçın Arısoy and Assoc.Prof.Dr. Gülnur Ballice for providing critical suggestions in thesis defense examination.

I especially wish to thank Prof.Dr. E. Eti Akyüz Levi, head of the Department of Restoration, at Faculty of Architecture, Dokuz Eylül University, for her allowance and tolerance during the thesis. In addition, my special thanks go to Dr. Funda Adıtatır for her kind guidance in approaching historic and archival sources, and ARK İnşaat and Architect Temel Aktürk for providing me complete documentation and other datasets of the case study. Besides, I would like to express my thanks to my dear colleagues and friends, first to Conservation-architect Tuđba Sarıcaođlu for her support during the thesis submission process, and second to Architect A. İlker Yalınır for his technical help. Last but not least, I am especially indebted to my family, who have always been there with their endless love. Besides, I am thankful to them for moral support and patience while getting over various types of difficulties. This thesis is dedicated to them.

## ABSTRACT

### DEVELOPMENT OF A DATABASE FOR THE RESTITUTION PHASES OF KURŞUNLU KHAN IN MANİSA

Historic buildings are not constant assets, they are representations of mankind and cultural systems throughout the time. In such a context, it is important to enlighten the process of building's evolution by means of restitution(s), i.e., descriptions of different (re)compositions of buildings for different historical states. Hence, restitutions are used as works of synthesis in architectural conservation, and it is a mandatory part for it. On the other hand, representation of information beyond geometric, spatial and physical characteristics of a historic building carries a crucial importance for a holistic understanding of changes in those restitutions. This requirement is a multi-fold manner consisting of representation, archival, assessment and management aspects. Regarding those aspects, databases offer promising possibilities. Nevertheless, covering the requirement of the restitution state(s) is yet quite challenging if also visualization in digital three dimensional (3D) platform is considered, which is the most desirable way since it offers users an unrestricted and holistic visualization. Accordingly, this thesis proposes a methodology for the development of a database for the restitution states of a historical monument covering not only geometric and spatial aspects, but also historical resources. The thesis has a motivation to make sharing of restitution information, and decreasing future investigation effort in order to reach information of different historic periods. In this frame, *Kurşunlu Khan* in Manisa, Turkey, a typical building type of Ottoman architecture (*şehiriçi hanı*), dating back to 15<sup>th</sup> century, is selected for testing the methodology. The principles for collection and analysis of the data regarding the case study, structuring the database, and its visualization and access possibilities are defined.

The thesis concludes that database may be an efficient tool supporting both the planning of a restoration project, and archiving of comprehensive results for later interventions and research. The resulting visualization options through the database and semantically enriched 3D model effort to make an easier understanding of historic changes specific to the monument. The database is open for improvement with conservation-aimed information.

## ÖZET

### MANİSA'DAKİ KURŞUNLU HAN'IN RESTİTÜSYON EVRELERİ İÇİN BİR VERİTABANI GELİŞTİRİLMESİ

Tarihi yapılar durağan varlıklar değildir; zaman içinde değişen kültürel ve toplumsal sistemlerin birer temsilcisidir. Bu bağlamda, restitüsyon(-lar) aracılığı ile yapının değişim sürecini aydınlığa kavuşturmak, diğer bir deyişle yapının farklı tarihsel dönemlerdeki yeniden-kurulumlarını açığa çıkarmak büyük bir önem taşımaktadır. Bu nedenle, mimari koruma disiplininde restitüsyonlar sentez bilgi ürünleri olarak yer almaktadır ve herhangi bir mimari koruma etkinliğinin vazgeçilmez bir parçasıdır. Diğer yandan, tarihi yapının fiziksel ve mekansal özelliklerinin ardında kalan bilginin sunumu restitüsyonlarda ifade bulan tarihsel değişimlerin bütüncül algısı için kritik bir önem taşımaktadır. Bu gereklilik çok yönlü bir konu olup, sunum, arşivleme, erişim ve yönetim özelliklerini kapsamaktadır. Bu özellikler konusunda veritabanları gelecek vaat eden olanaklara sahiptir. Ancak, bu konu restitüsyon(-lar) kapsamında değerlendirildiğinde ve bununla birlikte bütüncül ve kısıtsız algılama olanağı tanıyan üç boyutlu (3B) dijital bir platformda sunum imkanı da gözetildiğinde oldukça zorlayıcı bir bağlamdır. Bu tez, tarihi bir yapının restitüsyon dönemleri için veritabanı geliştirmek üzere bir yöntem önermekte olup yapının sadece fiziksel ve mekansal özellikleri değil aynı zamanda tamamlayıcı restitüsyon bilgilerini de kapsamaktadır. Bu çalışma, gelecekte yapıya dair restitüsyon bilgisine ulaşmak için yapılan araştırma süresini kısaltmak yani restitüsyon bilgisinin paylaşılabirliğini sağlamak amaçlanmaktadır. Bu çerçevede, Osmanlı mimarisinin tipik bir yapı (şehiriçi hanı) örneği olan ve 15. yüzyıla tarihlenen, Manisa'daki Kurşunlu Han örneklem olarak seçilmiştir. Veri toplama ve değerlendirme, veritabanının kurgulanması ile sunum ve erişim konularına dair ilkeler tanımlanmıştır.

Sonuç olarak, veritabanının restorasyon projesini planlama sürecine destek veren ve gelecekteki müdahalelere ve araştırmalara yönelik sonuçların kapsamlı arşivlenmesi için etkili bir araç olabileceği ortaya konulmuştur. Veritabanı ve semantik olarak zenginleştirilmiş 3B model aracılığıyla elde edilen sunum biçimleri anıta özgü tarihsel değişimlerin daha kolay anlaşılmasını sağlamaya çalışmaktadır. Veritabanı koruma amaçlı bilgi ile geliştirilmeye açıktır.

# TABLE OF CONTENTS

|   |     |
|---|-----|
| LIST OF FIGURES.....  | ix  |
| LIST OF TABLES.....   | xii |
| CHAPTER 1. INTRODUCTION.....                                | 1   |
| 1.1. Statement of the Problem.....                          | 2   |
| 1.2. Theoretical Background.....                            | 6   |
| 1.3. Aim and Content.....                                   | 14  |
| 1.4. Method.....  | 14  |
| 1.5. Limitations.....                                       | 18  |
| 1.6. Organization of the Thesis.....                        | 18  |
| CHAPTER 2. ANALYSIS OF DATA REGARDING THE CASE STUDY.....   | 21  |
| 2.1. A Brief Look to the Pre-Ottoman Period.....            | 22  |
| 2.2. Formation of the Ottoman Cityscape.....                | 23  |
| 2.2.1. Understanding the Period's Architectural Style.....  | 24  |
| 2.2.2. The Concept of Külliye.....                          | 25  |
| 2.2.3. Shaping the Commercial Core of the Ottoman City..... | 27  |
| 2.3. The Image of the Sanjak of Saruhan (Manisa).....       | 28  |
| 2.3.1. The Commercial Activities in Manisa.....             | 33  |
| 2.3.2. The Commercial Center of Manisa.....                 | 40  |
| 2.4. The Case Study: Kurşunlu Khan in Manisa.....           | 41  |
| 2.4.1. The Concept of "Khan".....                           | 44  |
| 2.5. Architectural Characteristics of Kurşunlu Khan.....    | 47  |
| 2.6. Comparative Study.....                                 | 55  |
| 2.7. Restitution States of Kurşunlu Khan.....               | 57  |
| 2.7.1. Original State (1498).....                           | 57  |
| 2.7.2. 2nd State (1643).....                                | 60  |
| 2.7.3. 3rd State (1848).....                                | 62  |
| 2.7.4. 4th State (1908).....                                | 64  |
| 2.7.5. 5th State (1954).....                                | 64  |
| 2.7.6. 6th State (1966-1970).....                           | 65  |

|   |     |
|---|-----|
| 2.7.7. As-found State (2011).....   | 70  |
| CHAPTER 3. STRUCTURING OF THE RESTITUTION DATABASE.....                                     | 72  |
| 3.1. Terminology.....   | 72  |
| 3.2. Preliminary Experiments .....  | 74  |
| 3.2.1. Experimentation with BIM.....  | 75  |
| 3.2.2. Experimentation with GIS.....  | 77  |
| 3.3. A Critical Look at the Approaches .....  | 78  |
| 3.4. Definition and Characteristics of the Proposed Approach.....                           | 80  |
| 3.4.1. Conceptual Data Model.....   | 81  |
| 3.4.1.1. Identification and Classification.....   | 81  |
| 3.4.1.2. Setting Relationships .....  | 85  |
| 3.4.1.3. Graphical Notation of the Conceptual Model.....                                    | 86  |
| 3.4.1.4. Definition of Attributes .....   | 88  |
| 3.4.2. Spatial Data Model.....  | 89  |
| 3.4.2.1. Generation of Building Elements for Successive<br>Restitution States.....          | 95  |
| 3.4.3. Logical Data Model.....  | 95  |
| 3.4.4. Physical Data Model .....  | 97  |
| 3.4.4.1. Population of the Database .....   | 98  |
| 3.4.5. Data Access and Visualization.....   | 99  |
| CHAPTER 4. EVALUATION AND CONCLUSION.....   | 106 |
| 4.1. Evaluation of Kurşunlu Khan .....  | 106 |
| 4.2. Findings of the Proposed Restitution Database .....                                    | 108 |
| 4.3. Direction for Future Studies.....  | 111 |
| BIBLIOGRAPHY.....   | 113 |
| APPENDICES  |     |
| APPENDIX A. VISUALIZATION OF THE ORIGINAL STATE (1498) IN<br>ARCSCENE MODULE OF ARCGIS..... | 125 |
| APPENDIX B. VISUALIZATION OF THE 2nd STATE (1643) IN ARCS<br>CENE MODULE OF ARCGIS.....     | 126 |
| APPENDIX C. VISUALIZATION OF THE 3rd STATE (1848) IN ARCS<br>CENE MODULE OF ARCGIS.....     | 127 |

|   |     |
|---|-----|
| APPENDIX D. VISUALIZATION OF THE 4th STATE (1908) IN ARCSCE<br>MODULE OF ARCGIS.....  | 128 |
| APPENDIX E. VISUALIZATION OF THE 5th STATE (1954) IN ARCSCE<br>MODULE OF ARCGIS.....  | 129 |
| APPENDIX F. VISUALIZATION OF THE 6th STATE (1966-1970) IN<br>ARCSCE MODULE OF ARCGIS.....   | 130 |
| APPENDIX G. VISUALIZATION OF THE AS-FOUND STATE (2011) IN<br>ARCSCE MODULE OF ARCGIS.....   | 131 |
| APPENDIX H. BUILDING QUERY IN ARCSCE (3rd STATE) E.G. 2ND<br>DEGREE RELIABLE STRUCTURAL ELEMENTS .....                                | 132 |
| APPENDIX J. BUILDING QUERY IN ARCSCE (6th STATE) E.G. 1ST<br>DEGREE RELIABLE STRUCTURAL ELEMENTS MADE<br>OF CONCRETE .....            | 133 |
| APPENDIX K. BUILDING QUERY IN ARCSCE (AS-FOUND STATE)<br>E.G. ELEMENT ADDITIONS.....  | 134 |
| APPENDIX L. DATA VISUALAZITION IN ARCSCE (5th STATE) E.G.<br>PHOTOGRAPH OF NORTHERN FAÇADE AS SOURCES<br>OF RESTITUTION .....         | 135 |
| APPENDIX M. DATA VISUALAZITION IN ARCSCE 6th STATE E.G.<br>PHOTOGRAPH OF COLLONADED PORTICO AS<br>SOURCES OF RESTITUTION .....        | 136 |
| APPENDIX N. DATA VISUALAZITION IN ARCSCE (AS-FOUND<br>STATE) E.G. PHOTOGRAPH OF COLLONADED<br>PORTICO AS SOURCES OF RESTITUTION ..... | 137 |
| APPENDIX P. DATA VISUALIZATION IN GUI (RESTITION STATES) .....  | 138 |
| APPENDIX R. DATA VISUALIZATION IN GUI (SPACES PER PHASE) .....  | 139 |
| APPENDIX S. DATA VISUALIZATION IN GUI (BUILDING ELEMENTS<br>PER SPACE) .....  | 140 |
| APPENDIX T. DATA VISUALIZATION IN GUI (IMAGES PER PHASE) .....  | 141 |
| APPENDIX U. DATA VISUALIZATION IN GUI (EXTERNAL DATA).....  | 142 |
| APPENDIX V. DATA VISUALIZATION IN GUI (EXTERNAL DATA)<br>E.G. ART HISTORY REPORT .....  | 143 |
| APPENDIX Y. TABULAR DATA EXTRACTION .....   | 144 |



## LIST OF FIGURES

| <b><u>Figure</u></b>  | <b><u>Page</u></b> |
|---|--------------------|
| Figure 1. The typical pipeline of conservation activities for a historic building. ....   | 3                  |
| Figure 2. A typical pipeline of as-built BIM approach (Source Huber et al. 2011). ....  | 7                  |
| Figure 3. The change of mass volume in time (Source: Fai et al. 2013). ....   | 8                  |
| Figure 4. The process of geometric modeling in h-BIM approach.....  | 9                  |
| Figure 5. Visualization of restitution states in NUBES platform and (De Luca et al. 2011).....  | 10                 |
| Figure 6. Access to information in GIS platform (Source: Centofanti 2011).....  | 11                 |
| Figure 7. The organization of the thesis.....   | 20                 |
| Figure 8. Map of Anatolia showing trade routes (17th century) (Image is re-drawn on the basis of the map by Aktüre 1981).....   | 24                 |
| Figure 9. Map of Anatolia Province in 1530 (Source: 166 Numaralı Muhasebe-i Vilayet-i Anadolu Defteri). ....  | 30                 |
| Figure 10. Map of Sanjak of Saruhan (Manisa) in 1530 (Source: 166 Numaralı Muhasebe-i Vilayet-i Anadolu Defteri). ....  | 30                 |
| Figure 11. View of Manisa in the late 16th century. In the center is the princely palace, the mosque of Hüsnüşah Khatun lies just above, while the mosque of Külliye of Sultaniye, with two minarets and an outdoor prayer courtyard, lies slightly below the larger mosque of Külliye of Muradiye in the upper right. (Source: Pierce 1993, Image Courtesy, Topkapı Palace Museum Library, Istanbul). .... | 32                 |
| Figure 12. Historical trade network of Western Anatolia from 1550s to 1750s (Image is re-drawn on the basis of the map by Luther 1989).....   | 35                 |
| Figure 13. View of Manisa in 17th century (Source: Peeters 1685).....   | 37                 |
| Figure 14. The engraving of Tournefort describing Manisa in 18th century (Source: Yerasimos 2005). ....   | 37                 |
| Figure 15. The map of Ottoman telegraph network in 1874 (Source Danforth 2013, image courtesy Atatürk Library, DSCN5503 and DSCN5504). ....   | 38                 |
| Figure 16. The Map of Ottoman rail network on the eve of World War I (Source Danforth 2013, image courtesy Atatürk Library, DSCN5503 and DSCN5504). ....  | 39                 |

|  |    |
|--|----|
| Figure 17. Sketch plan of Manisa. (On the very left hand side there is Kurşunlu Khan, the mosque of Hüsnişah Khatun, Hatuniye Mosque, lies just below, while the main axis follows towards right with other complexes on it.) (Source: Wittek 1931)..... | 43 |
| Figure 18. View of Hatuniye Mosque. Kurşunlu Khan’s Northern facade can be seen partially on the left hand side. In the background, Sipil (Sipylus) Mountain. (Source: Wittek 1931).....   | 44 |
| Figure 19. (a) Aerial image of Kurşunlu Khan, viewed from Northwest, (b) and (c) Northern view of Kurşunlu Khan, (d) Main entrance on the West facade, (e) Secondary entrance on the East facade. (Source: Saygı 2015).....                              | 48 |
| Figure 20. Site Plan of Kurşunlu Khan showing as-found state (Source: ARK İnşaat 2011). .....  | 49 |
| Figure 21. West and North Facades of Kurşunlu Khan showing as-found state (Source: ARK İnşaat 2011). .....   | 50 |
| Figure 22. South and East Facades of Kurşunlu Khan showing as-found state (Source: ARK İnşaat 2011). .....   | 50 |
| Figure 23. Section of Kurşunlu Khan showing as-found state (Source: ARK İnşaat 2011). .....  | 51 |
| Figure 24. Floor plans of Kurşunlu Khan showing as-found state (Source: ARK İnşaat 2011). .....  | 52 |
| Figure 25. Partial photo of the North (left hand side) and South (right hand side) facades in which masonry works can be easily distinguished (Source: Saygı 2015).....  | 54 |
| Figure 26. Photo showing the two-color application of stonework at the main entrance. ....   | 54 |
| Figure 27. Restitution of the Original State (1498) and its reliability. ....  | 59 |
| Figure 28. Restitution of the 2nd State (1643) and its reliability.....  | 61 |
| Figure 29. Restitution of the 3rd State (1848) and its reliability. ....   | 63 |
| Figure 30. Restitution of the 4th State (1908) and its reliability. ....   | 67 |
| Figure 31. Restitution of the 5th State (1954) and its reliability. ....   | 68 |
| Figure 32. Restitution of the 6th State (1966-1970) and its reliability. ....  | 69 |
| Figure 33. Measured drawings of As-found State (2011) and alteration analysis.....   | 71 |
| Figure 34. Workflow in BIM environment.....  | 75 |

|   |     |
|---|-----|
| Figure 35. Workflow in GIS environment.....   | 77  |
| Figure 36. Overall workflow and architecture.....   | 81  |
| Figure 37. Reading a building and identification of features.....                                   | 82  |
| Figure 38. Tree graph representing the classes used for Kurşunlu Khan. ....                         | 85  |
| Figure 39. UML diagram for the case study (Source: Booch et al. 1999).....                          | 87  |
| Figure 40. Exploded view of the (partial) segmented 3D model.....                                   | 91  |
| Figure 41. View of the 3D geometric model and layer system in Autodesk<br>3DS Max environment. .... | 93  |
| Figure 42. The structure of the naming used in 3D modeling process. ....                            | 94  |
| Figure 43. The logical data model used for the study.....   | 96  |
| Figure 44. Example of visualization in ArcScene module of ArcGIS.....                               | 102 |
| Figure 45. Web-based visualization of the database (restitution states).....                        | 104 |
| Figure 46. Example of the tabular data extraction.....  | 105 |

## LIST OF TABLES

| <b><u>Table</u></b>   | <b><u>Page</u></b> |
|---|--------------------|
| Table 1. Current approaches. ....   | 12                 |
| Table 2. Conceptual principle followed for reliability levels. ....   | 16                 |
| Table 3. Restitution states in the thesis and its adaption from restitution phases by<br>ARK İnşaat. ....                                 | 17                 |
| Table 4. Comparison of Kurşunlu Khan with other khan examples of the period .....   | 56                 |
| Table 5. Comparison of the capabilities of BIM and GIS for the semantically<br>enriched 3D model creation (Saygı and Remondino 2013)..... | 78                 |
| Table 6. The classes and their definitions in the proposed data model .....   | 83                 |

# CHAPTER 1

## INTRODUCTION

To what extent may a space be read or decoded? A satisfactory answer to this question is certainly not just around the corner...without as yet adducing supporting arguments or proof, the notions of message, code, information and so on cannot help us to trace the genesis of a space; the fact remains, however, that an already produced space can be decoded, can be read... (Lefebvre, 2000)

Lefebvre (2000) in his book “Production of Space” has brought a new paradigm shift on (social) space underlying the fact that space is not what we just see, it is more complex than geometric space, e.g., surfaces, juxtapositions, etc. Therefore, the space is actually more perceptual and related to our practices. This shift Lefebvre brought in his controversial argument against the reduction of a space into the geometric spaces can be applied as a larger perspective for the heritage buildings. Because, a heritage building is not just a volume of the geometric features (Hansar 2008) or an abstract sum of spaces, all of the features together involve in description of invisible or hidden information, meanings and values behind the imagery. Moreover, heritage buildings undergo continuous change over their lifespan due to adaptations, repair, conservation, etc. (Letellier 2007). Hence, any conservation-architect starts a (scientific) journey, i.e., research and investigation, for each individual heritage building and aims to re-establish the potential unity, i.e., “wholeness” (Brandi 2005). Therefore, one does not just consider conservation of the physical/geometric form of any heritage building, but also its content and history (Matero 2007). To that end, a conservation-architect needs to mediate both retrospective and prospective visions for any heritage object in architectural conservation discipline for de-coding and reading the spaces. Throughout this mediation, many questions, similar to the ones listed below, appear in her/his mind:

- How did the spaces become transformed?
- Which changes did the building undergo?
- What are the (remaining) original components?
- What kind of spaces were made up with the architectural components in other historic periods?

The list can be extended with many other questions, but all intersect with the aim of reaching the “wholeness” for any heritage building: first to discover, understand, and represent, then to manage and conserve. Correspondingly, a conservation-architect has to reach definitions of the former time intervals, so collects information between past and present, and attempts to understand the heritage building in a retrospective way of thinking. As a consequence, the journey has a comprehensive and overlaying form of both mental and practical process.

### **1.1. Statement of the Problem**

Every heritage building is a unique historical archive, and a typical investigation of any covers different but yet complimentary research steps. A typical pipeline starts with on-site data acquisition, hands-on investigations of building’s qualifications which results with the production of measured drawings showing as-found state of the heritage building. It continues with complimentary archival and historical research, and comparative study for supporting analysis which is a comprehensive process covering spatial and/or element alterations (transformations, removals, additions), structural failures or deformations, and material deteriorations. All of them are synthesized in restitutions, i.e., (re)composition of the building in different historic time intervals. Besides, a critical evaluation is done in order to be aware of physical aspects and the aspects beyond them. Within the light of all those process, intervention decisions are developed with regard to the proposed restoration projects. As a consequence, restitution(s) of any heritage building, i.e., deciphering the evolution of the building during its timespan is an indispensable part of any conservation activity (Figure 1).

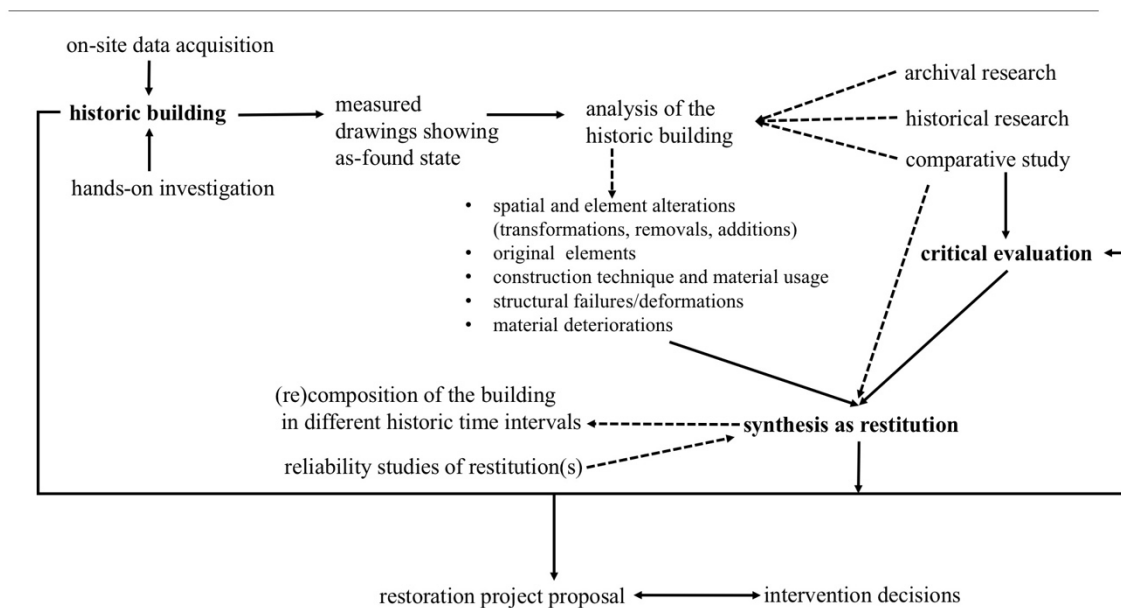

Figure 1. The typical pipeline of conservation activities for a historic building.

The creation of a holistic repository in terms of a restitution database dedicated to understanding the evolution of a historic building has a great importance, and it gives the possibility to use systemized and structured information for an entire perception of the different restitution states of a building. Nevertheless, it should not only be considered as an integral activity supporting the intervention decisions of architectural conservation but also an important knowledge as unique expression of human achievement to transmit future generations (Letellier 2007). In this frame, data/information types with respect to the evolution of a heritage building, i.e. restitution states, the management of those information in terms of database, access to information through three-dimensional (3D) model, and the concept of digital heritage are discussed in the following:

First, research and investigation is a priori step for any conservation activity. In this context, existing sources of heritage information should be found and examined accurately for identifying the historic monument and its setting. Besides, complimentary information gathered through prior research and investigation is represented through the visual reconstructions by artists, architects, or computer modelers which are based upon detailed and systematic analysis of environmental, archeological, architectural and

historical data (ICOMOS 2008). Moreover, the Charter for the Interpretation and Presentation of Cultural Heritage Sites (2008) by ICOMOS<sup>1</sup> highlights that information sources should be clearly documented, and alternative sources should be provided for comparison. Correspondingly, the related information can be classified into two: (i) geometric information (2D drawings, 3D models, geographical location), and (ii) non-geometric information which covers both textual ones (archival information, written documents) and raster ones (photographs, old maps, scanned documents/reports, diagrams, sketches).

Second, it is very important to create a common medium allowing access to the existing information, which does not only allow significant savings in budget but also in time (Letellier 2007). RecorDIM initiative by Getty Conservation Institute (2007) underlines the importance of developing information management strategies for historic buildings and highlights a very basic but crucial point: if information is not properly archived, it is lost information. Moreover, when charters and other doctrinal documents by ICOMOS are reviewed, a number of articles describing the critical aspects and the importance of archiving and assessing produced information are found. Foremost important, in the masterpiece Venice Charter (1964) for the architectural conservation discipline, the importance of placement of all records which are available to researchers is underlined. In addition, the Principles for the Recording of Monuments, Groups of Buildings and Sites (1996) underlies that the information should be preserved in a safe archive, and must ensure permanence in an indexed environment to facilitate the exchange and retrieval of information, the importance of implementation of up-to-date information management technologies, and the accessibility of data for facilitating exchange for the present and future researchers. Within the light of those, and considering the advances in information technologies, databases are found as powerful tools which can be applied for historic building.

Third, digital reconstructions of historic buildings in digital three-dimensional (3D) platform is the most desirable way since it offers users an unrestricted and holistic visualization (El-Hakim et al. 2007). But that, those pure geometric information is not enough to understand complex and rich history beyond the physical aspects of a historic building. Besides the current 3D building information modelling software consist full

---

<sup>1</sup> International Council on Monuments and Sites; it is the only global non-government organization, which is dedicated to promoting the application of theory, methodology, and scientific techniques to the conservation of the architectural and archaeological heritage.



architectural properties (dimensions, material, texture, etc.), but there is lack of integration of new information different than the properties of industrialized/standardized modern buildings. Nevertheless, that data/information is not explicit in graphical representations which are important for understanding specific architectural/historical style and characteristics of the historic phases of any heritage building. The aspects of rich annotation of restitution datasets in 3D, i.e., semantic enrichment for representing the evolution of any historic building is quite differentiating then modern ones, and up-to-date the applications are limited in the topic.

Fourth, UNESCO<sup>2</sup> (2003) in the Charter on the Preservation of the Digital Heritage emphasize the digital heritage's importance consisting unique resources of human knowledge and expression as it covers cultural, educational, scientific and administrative resources, as well as technical, legal, and other kinds of information which are either digital creations or conversions into digital form from existing analogue resources. Moreover, the London Charter for the Computer-based Visualization of Cultural Heritage (2009) ensures a methodological rigor of computer-based visualization for research and communication and sets principles ensuring digital heritage to be intellectually and technically exact and accurate. It underlines the importance of setting relationship between research sources, implicit knowledge, explicit reasoning, and visualization in order to make evaluative, analytical, deductive, interpretative and creative decisions. Other than these, the CIDOC Conceptual Reference Model (CRM) by ICOM<sup>3</sup> intends to promote shared understanding of cultural heritage information by providing a common and extensible semantic framework that any cultural heritage information can be mapped by the provided definitions, structure, implicit and explicit concepts and relationships. Nevertheless, this study does not directly support standards of neither RecorDIM by Getty Conservation Institute nor Cidoc-CRM by ICOM (ISO 21127:2006), but uses their principles and corresponds the standard of the needs taking different types of different layers of information of a historic building. Besides, it is crucial to preserve the produced digital heritage ensuring that it remains accessible. In this context, the rapid obsolescence of

---

<sup>2</sup> United Nations Educational, Scientific and Cultural Organization; it is the agency aiming to create holistic policies that are capable of addressing the social, environmental and economic dimensions of sustainable development.

<sup>3</sup> International Council of Museums; it is an organization is committed to ensuring the conservation, and protection of cultural goods, and sets standards for museums in design, management and collections organization.

the hardware and software, and responsibility and methods for maintenance and preservation, and supportive legislation should be taken into consideration.

As a consequence, a heritage building is a historic record including different types of information. The management of the heterogenous information related to heritage building, in particular its restitution states, includes different steps such as the production of the information, its analysis, evaluation, systematization, visualization, archiving, access and preservation. The optimal way is to integrate all restitution information through the 3D model with semantic enrichment by implementing a database. Besides, the produced semantically enriched 3D model is a (digital) heritage, like the historic building itself. Nevertheless, current approach in the topic is not yet applicable for historic buildings, covering generally the properties of modern buildings. As a result, it is an open research problem to describe a methodology for the creation of a database for the restitution states of a historic building covering also access through semantically enriched 3D model.

## **1.2. Theoretical Background**

Recent research interests proved the importance of databases in terms of semantically enriched 3D models as digital information containers for historic buildings. The researches are categorized into four: as-built BIM approach, h-BIM approach, stand-alone systems and GIS approach. And, those are evaluated within the following topics: considered data types, integration of restitutions (historic states), their information management application, access possibilities for 3D model, and the concept of digital heritage.

First, the concept of as-built BIM, which derives from Building Information Modeling (BIM) (Eastman et al. 2011), is a new paradigm and representation mode derived from the management necessities of architectural and engineering industry of buildings (Saygı and Remondino 2013). This approach could offer an interesting opportunity in heritage applications to manage 3D geometric information. A typical pipeline for as-built BIM generation is composed of the following chain (Hichri et al. 2013): (i) geometric data acquisition and creation of unstructured point clouds, (ii) segmentation into regions using several segmentation algorithms, (iii) production of 3D models, and (iv) enrichment using different recognition techniques. Regarding the segmentation phase, i.e. the identification of different architectural components

(building elements) in point clouds and 3D meshes. Besides, there are mainly four type of as-built BIM approaches, based on heuristics (Vosselman et al. 2004, Pu and Vosselman 2006, Rusu et al. 2009), context (Xiong and Huber 2010), ontologies (Yue et al. 2006) and prior knowledge (Hmida et al. 2012). However, it is not enough to detect the 3D meshes' sub-parts as building elements, e.g., walls, windows, doors, etc. (Figure 2). For example, if a wall is identified, it should be specified where this wall is connected, to which walls it is adjacent, and which architectural space(s) it is hierarchically part of (Saygı and Remondino 2013). Only in this way it is possible to define mutual relationships of the components with each other in a hierarchical order. In addition, building elements of historic buildings often lose their shape similarities over time because of deteriorations and alterations. So, for the production of semantically enriched 3D models of any heritage building, the use of automated segmentation algorithms or shape recognition is in fact not enough. As a matter of fact, most of the as-built BIM approach (Garagnani 2012, Attar et al. 2010, Apollonio et al. 2012, Oreni et al 2012 and 2013) focus only on the integration of the 3D geometric information to the information system ignoring the integration of data types differentiating than architectural characteristics. The approach by Yajing and Cong 2011 is developed for stone heritage and covers specific information types for stone deformation state and stone types. Besides, it offers visualization of restitution state. Nevertheless, the geometries are not hierarchically structured for any spatial analysis, and overall approach is limited to stone heritage. The approach by Fai et al. 2013 (Figure 3) attempts to indicate different restitution states of a building in history but the building is limited to outer envelope, i.e. mass volume. Last, approach is limited in terms of access to information and model, being bounded to a single workstation and specific software.

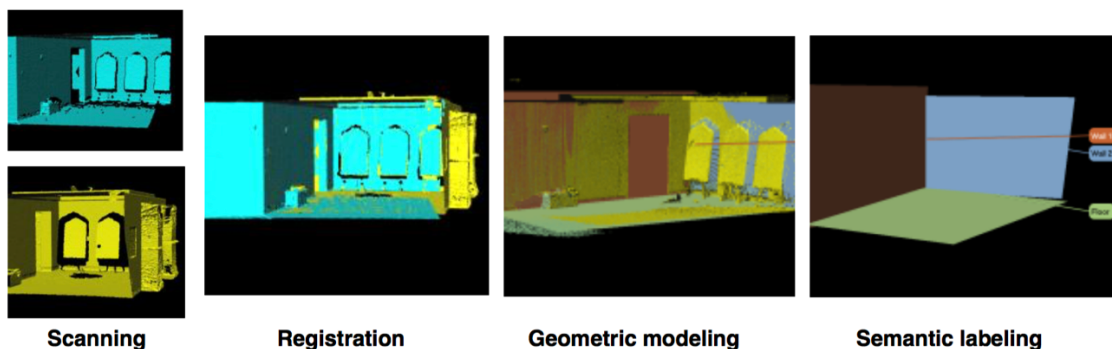

Figure 2. A typical pipeline of as-built BIM approach (Source Huber et al. 2011).

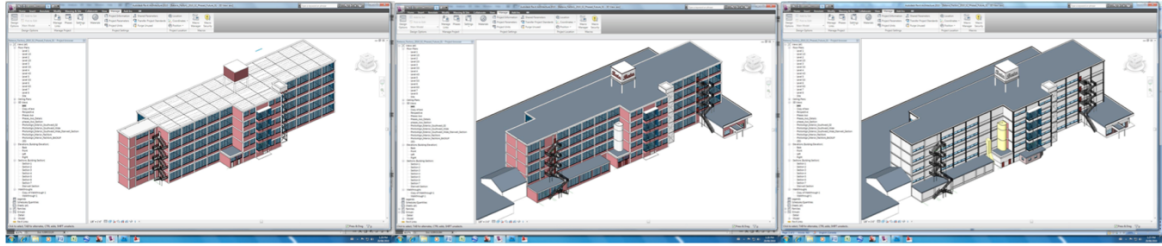
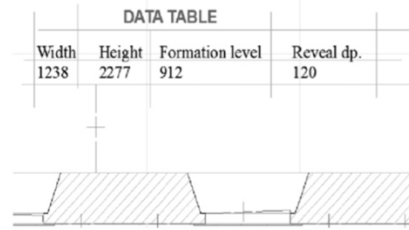
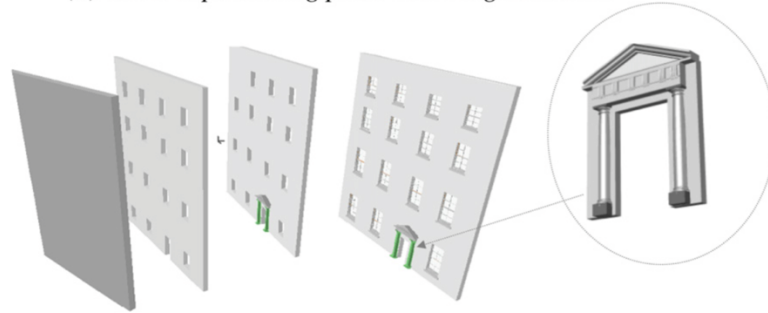

Figure 3. The change of mass volume in time  
(Source: Fai et al. 2013).

Second, h-BIM approach is based on parametric modeling (Figure 4), and the results of the approaches of Boeykens et al. (2012), Murphy et al. (2011 and 2013), Dore and Murphy (2012) can be very relevant in some specific geometric information of architectural styles (Saygi et al. 2013). However, such methods are not covering the semantic requirements of historic buildings at all as they are mostly characterized by varied shape components. Moreover, none of the building elements of any historic building is exactly horizontal or vertical, being often altered or deteriorated. Thus, modeling any building element becomes even harder because of those changes over time. Besides, some elements are even more complex such as carved ornamentations, stone moldings, etc., which have specific characteristics and differentiating architectural styles. Indeed, due to all these facts, building elements of historic buildings having quite common semantic features lose similarities at the level of their geometries (Saygi and Remondino 2013). As a result, it does not correspond to specific characteristics of historic buildings' geometric information. Besides, mutual and hierarchical relationships of building elements are either not focused or could not be applied, and it ignores the non-geometric data integration. More importantly, the approach does not cover different states of a building in history. Last, the approach is limited in terms of access to a single workstation and specific software like as-built BIM approach.



(a) Vector representing point cloud segmentation



(b) Sequence of 3D modelling of facade

Figure 4. The process of geometric modeling in h-BIM approach  
(Source: Murphy et al. 2013).

Third, there are a few examples of stand-alone systems. An innovative approach is the stand-alone information system named NUBES (De Luca et al. 2007 and 2011) developed by MAP-Gamsau Laboratory (CNRS Marseille, France). It covers both geometric and non-geometric information. It also covers visualizations of different states of a building in history (Figure 5), however the respective information, e.g., old photographs, historic texts for different phases are not integrated. Besides, the platform is yet not possible for access by other users. Other than that, the approach by Achille et al. (2012) and Arayici (2008) are promising too (Saygı and Remondino 2013). The presented information systems focus in geometric information. Architectural properties of geometries are considered, but it is limited in the integration of non-geometric information. Neither of them cover different restitution states of a building in history. More importantly, hierarchical structures and related query-able characteristics are not covered which makes the approach limited in terms of access and retrieval.

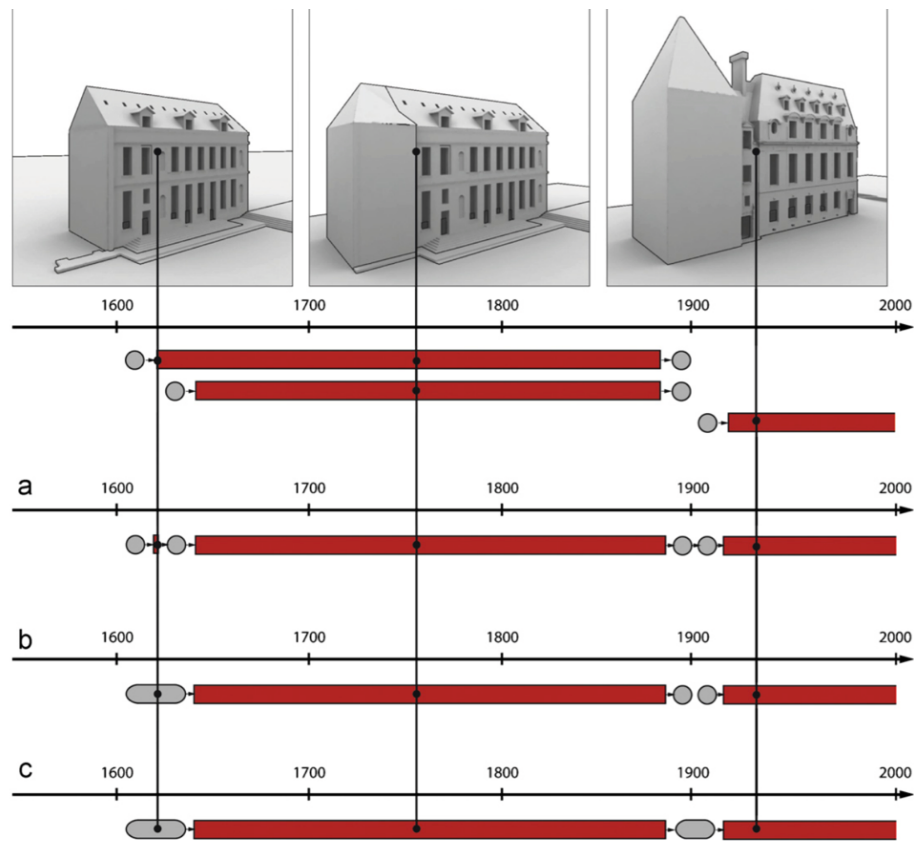

Figure 5. Visualization of restitution states in NUBES platform (Source: De Luca et al. 2011).

Fourth, from a controversial but promising perspective, regarding the concept of spatial data management in a broader sense, e.g., geology, land use, transportation, etc., the most common approach for implementing the geometry/object and relation structure is Geographical Information Systems (GIS). There are (some) prejudices regarding GIS when applied to heritage buildings, as the term "geographical" is understood as if it would refer to only X, Y, Z coordinates. However, GIS is not bounded to a local or global situation, it refers to geometric and spatial relationships (Saygı et al. 2013). In this frame, GIS allows geometric and non-geometric information storage based on a series of tables, where multiple relations between data and (building) elements can be defined (Crosswell 1991). The approach by Centofanti et al. (2011) and San José-Alonso et al. (2009) focused on discovering its potentials. In particular, Centofanti et al. (2011) integrates non-geometric information (raster or textual) to geometric information, whereas San José-Alonso et al. (2009) only focuses on material deteriorations on building's façade. It is possible to visualize and retrieve information

through the 3D model based on building elements (Figure 6). Nevertheless, the geometric and spatial integration, i.e., the relationships/hierarchies between the building elements and spaces are not covered in both. More importantly, non of them covers neither visualization for restitution states of a building in history nor related non-geometric information. Last, they only give access to the information through a single workstation by specific software.

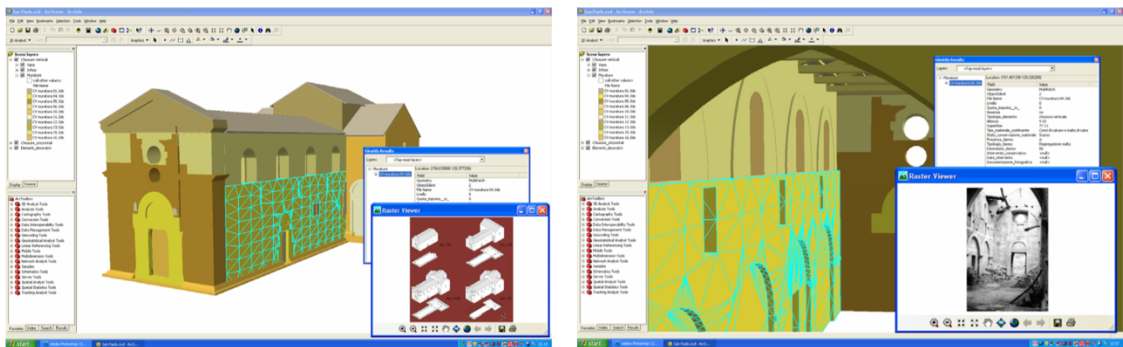

Figure 6. Access to information in GIS platform  
(Source: Centofanti 2011).

In conclusion, applications in this field are still in the early stages due to the multiple challenges of the topic. For instance, the past studies have ignored the integration of non-geometric information differentiating than architectural characteristics in 3D environment or they do not make heritage information accessible to others. In particular, a simple 3D model in a virtual environment for restitution states is not enough as it lacks any information about the historic building's internal structure and the hierarchical relations between the compounding building elements and spaces.

Table 1. Current approaches.

| Approach Type       | Reference Paper(s)           | Applied Case                                     | Used software                                       | Plug-in/ extension          | Semantic enrichment                                      | Restitution states                      | Inclusion of Restitution information |
|---------------------|------------------------------|--|---|-----------------------------|--|---|--------------------------------------|
| <b>as-built BIM</b> | Garagnani (2012)             | An Early Byzantine church                        | Autodesk Revit Architecture                         | Green Spider plug-in        | Limited to 3D geometries from unstructured point clouds. | not considered.                         | not considered.                      |
| <b>as-built BIM</b> | Yajing and Cong (2011)       | Stone heritage of Ta Keo Temple                  | 3D MAX, SketchUP, Geomagic, AutoCAD, Autodesk Revit | none                        | specific information for stone heritage.                 | original state is considered.           | not considered.                      |
| <b>as-built BIM</b> | Attar et al. (2010)          | Historic warehouses converted into offices       | Autodesk Revit, AutoCAD                             | gbXML extension, EnergyPlus | specific to energy efficiency.                           | not considered.                         | not considered.                      |
| <b>as-built BIM</b> | Oreni et al. (2012 and 2013) | Various types of historical vaults               | Leica Cloudwork , Autodesk Revit, AutoCAD, Rhino    | Leica Cloud Worx plug-in    | Limited to 3D geometries from unstructured point clouds. | not considered.                         | not considered.                      |
| <b>as-built BIM</b> | Apollonio et al. (2012)      | Palladian architecture – doric order             | Autodesk Revit                                      | none                        | Limited to 3D geometries based parametric modeling.      | not considered.                         | not considered.                      |
| <b>as-built BIM</b> | Fai et al. (2013)            | Urban cluster of 19th century heritage buildings | AutoCAD, Civil 3D, SketchUP, Revit, Navisworks      | none                        | Limited to 3D geometries based on parametric modeling.   | limited to outer envelope - mass volume | not considered.                      |
| <b>h-BIM</b>        | Boeykens et al. (2012)       | Prague Vinohrady synagogue                       | Graphisoft ArchiCAD Maxon, Cinema4D                 | none                        | Limited to architectural properties.                     | not considered.                         | not considered.                      |

(cont. on next page)



Table 1 (cont.).

| <b>Approach Type</b>       | <b>Reference Paper(s)</b>                  | <b>Applied Case</b>                               | <b>Used software</b>  | <b>Plug-in/extension</b>    | <b>Semantic enrichment</b>  | <b>Restitution states</b>               | <b>Inclusion of Restitution information</b> |
|----------------------------|--|---|---|-----------------------------|---|---|---|
| <b>h-BIM</b>               | Murphy et al. (2011), Murphy et al. (2013) | Various elements of classical architectural style | Graphisoft ArchiCAD   | none                        | Limited to 3D geometries based on parametric components' libraries. | not considered.                         | not considered.                             |
| <b>h-BIM</b>               | Dore and Murphy (2012)                     | A number of heritage buildings                    | Graphisoft ArchiCAD, Google SketchUp, CityGML                                   | Plug-in for SketchUp        | limited to architectural properties.                                | not considered.                         | not considered.                             |
| <b>GIS</b>                 | Centofanti et al. (2011)                   | A complex villa and two churches in Italy         | AutoCAD, 3D Studio Max, Rhinoceros Rapidform XOR, Microsoft Access, ESRI ArcGIS | none                        | is considered.  | not considered.                         | not considered.                             |
| <b>GIS</b>                 | José-Alonso et al. (2009)                  | Various heritage objects                          | PINTA combining CAD and GIS functionalities                                     | none                        | material deteriorations.  | not considered.                         | not considered.                             |
| <b>Stand-alone systems</b> | Achille et al. (2012)                      | Main Spire of Milan Cathedral                     | Rhinoceros, WEBGL, Back Office, Front Office                                    | Pointools for Rhino plug-in | Limited to architectural properties.                                | not considered.                         | not considered.                             |
| <b>Stand-alone systems</b> | Arayici (2008)                             | A heritage building under refurbishment           | IMMerge and IMEdit modules of Polyworks, Microstation                           | IFC plug-in                 | Limited to 3D geometries based on parametric components' libraries. | not considered.                         | not considered.                             |
| <b>Stand-alone systems</b> | De Luca et al. (2007 and 2011)             | A number of heritage buildings                    | MySQL, Virtools DEV, PHP, SVG, NUBES  | none                        | Limited to architectural properties.                                | limited to outer envelope - mass volume | not considered.                             |

### **1.3. Aim and Content**

This research starts from two basic, but important considerations. On one hand, any conservation activity is a continuous process and it requires a great understanding the building as a whole and explicit reasoning for decision-making. Besides, this process covers the critical evaluation of records, i.e., synthesis as restitution states showing the changes of the historic building in time. On the other hand, information technologies help organize, structure and manage information by means of electronic databases which facilitate access as well. In this context, this thesis efforts: first, integrating different information types such as geometric, textual and raster data regarding restitution of a historic monument in a semantically enriched 3D model, and second, creating a database for efficient archiving, access and preservation of this model.

*Kurşunlu* Khan in Manisa, Turkey is selected as the case study. The reason for the selection of the case study is a multi-fold manner: first, the building's complete documentation was available, second it was a widely studied building typology, and third, it had a series of changes due to interventions or repairs carried out in different time periods. Besides, over the centuries, the building stopped accommodating the function for which it was originally built for, and a number of modifications or conversions were necessary to adapt new uses. This led to a layered superstructure, which is very common in historic buildings. By this means, the chosen case study is suitable for illustrating changes in history.

### **1.4. Method**

The first step of this research, i.e., data collection is known as a long and effortful process in any conservation project for re-establishing "wholeness". Nevertheless, this study makes use of readily available information thanks to the collaboration with ARK İnşaat, a construction firm which provided measured drawings. Correspondingly, the data collection on-site has been limited just to on-site observations and investigations. The firm also provided the followings: restitutions, restitution report, restoration project, and other archival information as old photographs, related documents by the Izmir Number 1 Regional Conservation Council of Cultural and

Natural Wealth, and art history report by Süllü (2010). Other than these, the article by Oğuz (1974) entitled “Manisa Kurşunlu Han” provided comprehensive information specific to a previous restoration work dating back to 1966-1970. Moreover, the Ottoman Archive Catalogues by the General Directorate of State Archives of the Prime Ministry has also been an important resource for reaching the administrative or legal issues about the property. Besides, the translations of the Ottoman inscriptions of the pious foundation by Uluçay and Gökçen (1939) and Gökçen (1946) provided important resource. In addition, written accounts on the case are reached and evaluated. Moreover, complimentary readings in Ottoman history and architecture are done as secondary resources for a better understanding not only for old states of the building, but also, its setting, corresponding politics, culture and architectural style. More particular readings were on *şehiriçi hanları* in order to provide an architectural comparison for the case study and understanding of the building typology.

Following that, a special attention is paid in truthfulness of information sources is (ICOMOS 1994) which shapes one’s understanding of a heritage building in the historic and cultural contexts. Correspondingly, the sources in diverse forms, e.g. drawings, photographs, written accounts are compared, and it is only adopted in use if corresponds the criteria of being non-speculative and reliable information. As an exemplification, old photographs are sources with first degree reliability as they are non-speculative records or historic dates of the administrative documents coming from Ottoman archives are primary sources for the changes. Nevertheless, the content of those changes is not specified in detail (location, material, size, form, etc.). Accordingly, they have 2<sup>nd</sup> degree reliability level. In summary, the general conceptual principle for reliability levels shown in the Table 2 is followed, although the sources corresponding to each state is critically evaluated in detail.

Table 2. Conceptual principle followed for reliability levels.

| Reliability level               | Source type  |
|---------------------------------|--|
| 1 <sup>st</sup> degree reliable | Traces coming from the building itself<br>Old photographs  |
| 2 <sup>nd</sup> degree reliable | The charter of the pious foundation quoted from Süllü (2010)<br>Administrative documents from Ottoman Archive Catalogues Translation of old reports by Gökçen (1946)<br>Article by Oğuz (1974) describing the restoration works of 1966-1970 |
| 3 <sup>rd</sup> degree reliable | Written account by Acun (1999)<br>Comparative study  |

The third step of the research is the systematic categorization. Accordingly, the evaluated information on different restitution phases are categorized chronologically. Nevertheless, it should be noted that, the restitution phases by the ARK İnşaat is not directly adopted as some of the phases are found very wide for categorizing the historic periods. In this context, Table 3 illustrates how restitution phases by ARK İnşaat are adapted as restitution states in the thesis. Although a historic building is a dynamic asset, a static system of representation is applied which is a result of determinate changes of building elements or spaces in certain historic moments. Moreover, the changes with uncertainties are not covered as restitution states. For instance, a repair campaign or minor interventions for unspecified building elements or spaces can occur in an indefinite historic time interval. In such a case, it is found indeterminate both in terms of physical aspects (space) and specific moment (time), and is not considered as a specific restitution state.

Table 3. Restitution states in the thesis and its adaption from restitution phases by ARK İnşaat.

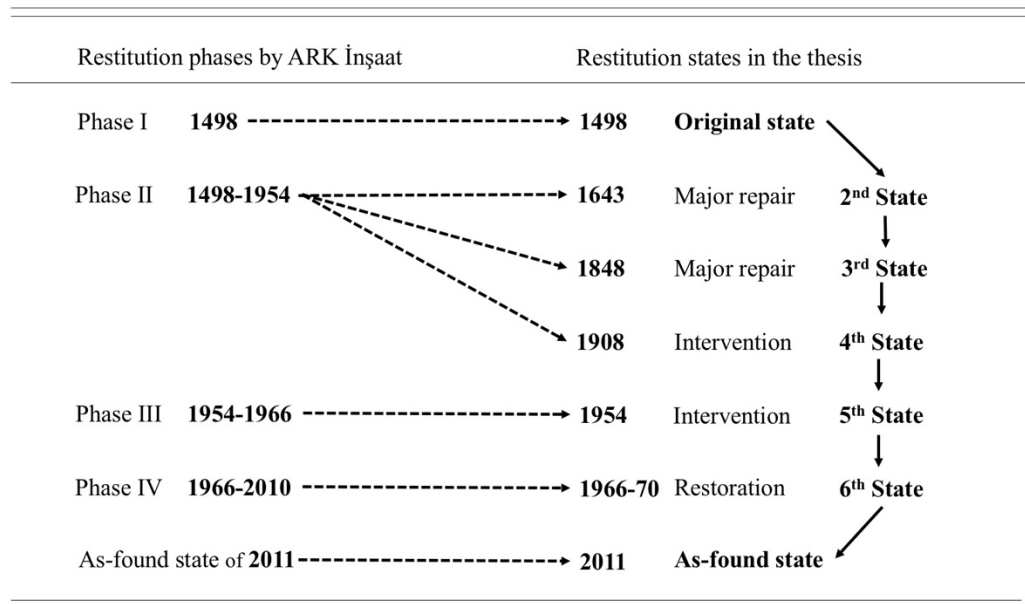

The fourth step is the selection and implementation of the database. Prior to that in-house methodologies within the light of current approach in the topic are tested out. And it is followed by their critical evaluation in order to support the selection decision for the appropriate information technology for structuring restitution database of the case study. More importantly, a hybrid methodological approach is adopted in systematic conceptualization, structuring and representation of information on restitutions. In particular production of complete geometric information, and its integration of with non-geometric information in a complete and holistic platform is considered. That is not a straight forward process, but it carries systematic structuring rules which takes three main concepts into consideration (a) segmentation – partitioning the buildings 3D geometry into meaningful sequences in terms of building elements, (b) structuring the hierarchies - setting relationships between building elements and spaces, and (c) semantic enrichment – integration of non-geometric information.

Last step is the evaluation of the restitution database in terms of data access and visualization possibilities, and its preservation within the discourse of digital heritage. Within this context, possible options are illustrated and exemplified with the use of different tools such as ArcScene module of ArcGIS for visualization of semantically enriched 3D model, Microsoft Excel for tabular data visualization.

The development of the restitution database required a combined use of tools. It can be listed as follows: Autodesk AutoCAD and Autodesk 3DS Max for the geometric information modelling, FME (Feature Manipulation Engine) for in-between data conversion and integration, PostgreSQL with the PostGIS extension, and its graphical user interface PgAdmin for database generation, PHP-based web GUI (graphical user interface) for administration.

## **1.5. Limitations**

This research is limited to the followings: (i) it does not cover neither automatic detection methods nor geometric-data collection throughout non-contact documentation techniques, (ii) only restitution states are covered in the database, neither analysis of the historic building nor intervention decisions of the restoration project are included; (iii) it does not consider a detail level up to architectural details, material deteriorations, but it allows holistic and easy understanding of different historic states of the case; (iv) it carries peculiarity of building elements regarding to the case's specific characteristics, so there exists a potential possibility that it will not fit exactly to any other historic building's needs. Nevertheless, the defined database structure is open to easy extension for other cases' needs; and (v) the developed database offers only two levels of access by information technologist and conservation-architect, hence different level of access to the information by different user groups beyond the scope of this study.

## **1.6. Organization of the Thesis**

The structure of this thesis is divided into four chapters (Figure 7). In this chapter, the scene of this research has already been set by reasoning where it stands for.

In the second chapter, the data regarding to the case study (*Kurşunlu Khan*) is analyzed indicating not only the building's architectural description, but also its historic evolution within the setting. Correspondingly, an integrated inspection regarding the context of the selected case is explored from architectural conservation point of view. Because, producing knowledge in order to advance the understanding of architectural heritage.

The third chapter is the technical core of the thesis. The structuring of the restitution database is covered which offers a new methodological approach dealing with the heterogeneous nature of heritage data. It also indicates the conceptual modeling, database generation, and its capabilities of access and visualization.

The fourth chapter includes remarks not only a critical evaluation of the case study within the cultural heritage discourse, but also findings of the developed restitution database with a critical reasoning about crucial points such as interoperability facts and translation processes. It also covers the evaluation of positive and negative aspects of it. Last, it covers where this thesis stands for, the outcomes, and the criticism of the proposed methodology in the architectural conservation framework.



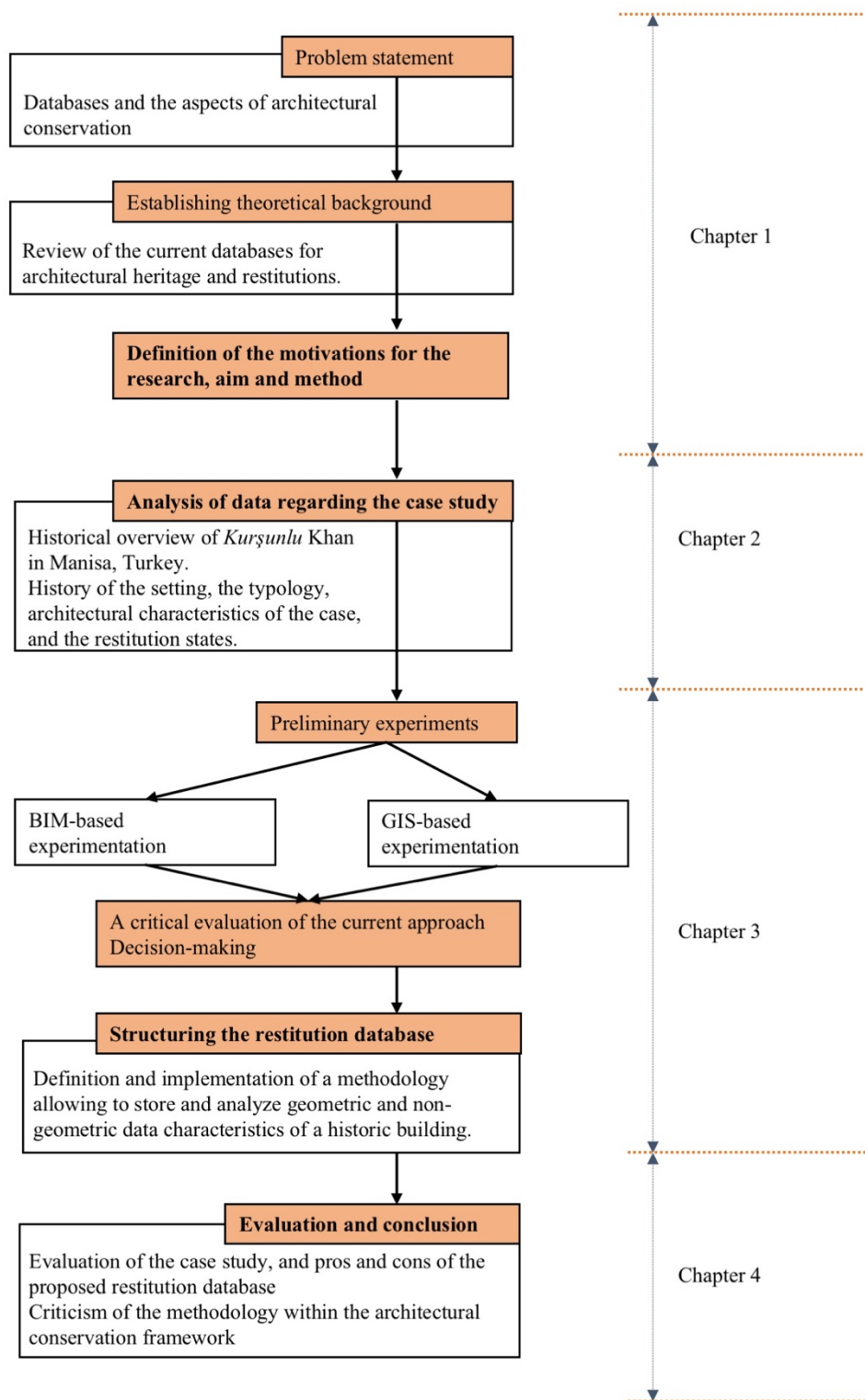

Figure 7. The organization of the thesis.



## CHAPTER 2

### ANALYSIS OF DATA REGARDING THE CASE STUDY

What is a historic building? ...one that gives us a sense of wonder and makes us want to know more about the people and culture that produced it. It has architectural, aesthetic, historic, documentary, archaeological, economic, social and even political and spiritual or symbolic values, but the first impact is always emotional, for it is a symbol of our cultural identity and continuity... (Feilden 2003)

In any historic building conservation project, which may range from minimal repairs to major interventions, the conservation-architect follows a similar path to a new design project. However, there exists a remarkable and greater investigation phase for understanding the building itself (Orbaşlı 2008). The level and depth of the information is dependent on the building and also the type of conservation that is proposed. But in each, the “reading” of a historic building requires a comprehensive research indicating the followings: (i) identifying its historic, cultural and functional significance, (ii) understanding the surroundings and its relation with other buildings, (iii) understanding the material and structural technology of the building, (iv) diagnosing minor and major alterations, material decay and its causes within the building (Orbaşlı 2008).

One of the indispensable part of this investigation are in order to decipher unique changes of historic buildings in different ways throughout time. Mostly, each historic building incorporates different layers from different periods as the physical traces of the history. So, what we “see” today is not old artifacts, but multi-layered representatives of the past of which researchers begin any investigation in the present (Watenpaugh 2004). In order to understand the history of the selected case with the above mentioned motivations in mind, this chapter is structured as the followings: The first section is devoted to giving a brief outline of the setting’s history, and in the second section, the Ottoman State’s city formation with the description of specific strategies, typical buildings, and the period’s architectural style is given. This is followed by the demonstration of the image of the Sanjak of *Saruhan* (Manisa) with a focus to its commercial center and life in the third section. In the fourth section, the case study, i.e., *Kurşunlu Khan* is introduced. Hence, Ottoman *şehirçi hanları* typology is

investigated for a complete understanding. The last three sections are dedicated to giving an extensive comprehension of the case study; therefore, architectural characteristics, material usage and construction techniques, and restitution states are introduced, consecutively.

## 2.1. A Brief Look to the Pre-Ottoman Period

The city of Manisa, ancient name Magnesia, is located at the northern skirts of *Sipil* (Sipylus) Mountain on a large plain, covering attractively rich agricultural areas next to the *Gediz* (Hermus) River in Western Anatolia. It covers the zone where the ancient civilization of Lydia arose. During the history, this area housed other important civilizations, e.g., Hellenistic, Roman and Byzantine, Persian prior to Turkish tribes' arrival (Ramsay 1890). In the Byzantine period, *themes* were the most important administrative divisions, and Manisa was a center episcopacy under the theme of *Thrakesion* after the 600s (Baykara 2015 quoted from Ostrogorsky 1981). Following the arrival of Turkish tribes as a consequence of Mongol incursions (Emecen 2013), Anatolia started to house small communities called Anatolian principalities attached to local leaders, i.e., Turkish beys (Goodwin 1971, Pitcher 1972). In 1081, Turkish tribes started to rule most of the the area. Besides, Byzantine population was decreased, and Byzantine cities became smaller (Baykara 2015) due to the weakening of Byzantine Empire in the late 13<sup>th</sup> century, there was only a few Byzantine settlements in Western Anatolia including Magnesia (Emecen 2013). One of the leading Anatolian principalities was *Saruhan*, which was a permanent power in that area, and it conquered Magnesia in 1313 (Uzunçarşılı 1984, Aydın 1997). Following that, *Saruhan* Principality started to transform the city's characteristics into Turkish-Islamic one (Emecen 2013). The old settlement located at the skirts of *Sipil* Mountain was greatly enlarged in the Northern direction on the plain during the ruling period of *Saruhan* Principality. At the same period, the Ottoman State had come into existence, in Western Asia Minor, not in a far location from Manisa (İnalçık and Quataert 1997). Consequently, the city was conquered by Beyazıd I in 1390, and added to Ottoman state. Nevertheless, it had to be regained by Ottomans in 1405 by the conquest of Mehmed I because of Timur's domination in all around Asia Minor starting from 1402. Moreover, the city's complete Ottoman administration was settled in 1415 (Emecen 2003). In the Ottoman Period, the

enlargement of the city continued, besides it was broadened in the East-West direction, in parallel to the growth of trade routes (Aktüre 1975).

## **2.2. Formation of the Ottoman Cityscape**

The character of a settlement with its spatial layout provides lots of clues for the urban societies in the history (İnalçık and Quataert 1997). There were mainly two parameters affecting settlements in Ottoman State at Asia Minor starting from 1400s:

The first parameter was the dependency on farming and its related economic benefits, i.e., water made farming more convenient. As a consequence, three zones of settlement in Asia Minor can be easily recognized in 1500s: first along *Kızılırmak* (Halys River) and *Yeşilirmak* (Green River), second in the valleys of small and large *Menderes* (Meander) and *Gediz* (Hermus), and last in the valley between *Dicle* (Tigris) and *Firat* (Euphrates).

The second parameter for the development of an Ottoman city is its position on the travel routes or closeness to harbors (Faroqhi 1994). The network of the trade routes in the greater state and the towns or cities as nodes of this network carried crucial importance. In the Ottoman Empire, those routes were also very important transportation networks linking different regions of the empire. Thus, those routes were mainly used by Ottoman merchants. Istanbul was connected to the places outside the Empire with three major trade routes: (i) in East-West direction, connecting Ottoman territories to Persian, with important nodes of Tabriz, Aleppo, Damascus, Diyarbakır, Konya and Bursa, which was used mainly for exporting spices, silk and luxury goods and importing textile works, gold and silver, (ii) in North-South direction, connecting Anatolia to Egypt and Syria, which was mainly for exporting essential nutrients and importing iron and wooden tools, and textile goods, (iii) in South-North direction, connecting Anatolia to the Northern parts of the Black Sea, into the Russian and Polish territories (Pamuk 2015) (Figure 8).

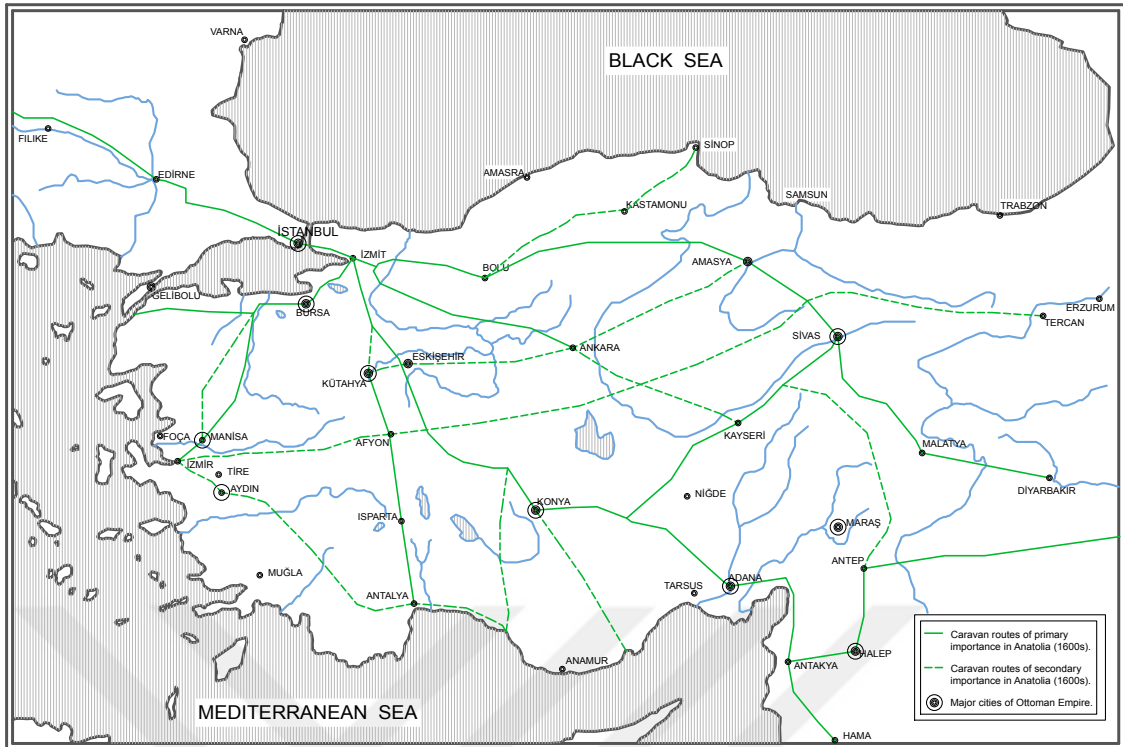

Figure 8. Map of Anatolia showing trade routes (17<sup>th</sup> century) (Image is re-drawn on the basis of the map by Aktüre 1981).

### 2.2.1. Understanding the Period's Architectural Style

Ottoman architecture had developed from 14<sup>th</sup> to 16<sup>th</sup> century, and it had taken the classical style and gave examples in a very large zone from *Tuna Nehri* (Danube River) to *Basra Körfezi* (Persian Gulf). The early period, in which architectural principles are determined, the details of ornamental applications and their style have taken their shape, was the most open period for foreign influences. In 14<sup>th</sup> century, Ottoman architecture was influenced mainly by the Western Anatolian principalities. Other than that, a synthesis of the hybrid medieval style of Anatolian Seljuk can be easily recognized. In that period, there is a large contradiction between the inner image and outer massive and cubic image of the buildings. After the second half of the 14<sup>th</sup> century, the dome is the fundamental element of Ottoman architecture enhancing the buildings' structures.

The first examples of the Ottoman architecture style itself with less influential codes started in the period of Beyazıd I (1389-1402) and continued along 15<sup>th</sup> century. This period followed by the huge interest in Westernization during the period of

Mehmed II, Conqueror (1451-1481), and the cultural spirit created in the period effected the idea of design constructions (Kuran 1997). The first examples of Ottoman classical style which mediates among Byzantine, Islamic and Italian Renaissance (Necipoğlu 2007) were seen in the period of Beyazıd II (1481-1512). An important parameter for this development was the establishment of *Hassa Mimarlar Ocağı* (The Corps of Royal Architects) around the same period. The association was managed by *hassa mimarbaşı* (the chief royal architect), and its due was to cover design, construction, survey and renovation works of all projects by pious foundations, including the cost management of them (Günay 2014). Moreover, the assignment of architects in charge, master builders and co-workers for any construction site was under the association's responsibility. On the other hand, this system allowed the management of nation-wide construction works from the imperial palace (Turan 2005). In other words, the absolute monarchy and the imperial centric art and architecture were directly related with one another (Kuban 2007). Besides, the organization mainly contributed to shaping the classical style and its development. There is, unfortunately, no document related to the establishment date of *Hassa Mimarlar Ocağı*, but it is claimed to have existed during Beyazıd II period (Günay 2014). Correspondingly, the classical period was the one where the cultural inputs were in the uppermost level and the aim was creating a unique style.

The Ottoman classical style was followed by the late period (1718-1922) adopting baroque, empiric and new-classical style by the influences of European architecture, continued by a responsive Islamic and Turkish style (Kuran 1997).

### **2.2.2. The Concept of *Külliy***

From another point of view, the buildings during the Ottoman Empire were crucial in order to represent the image of the city. Moreover, city centers were important nodes narrating urban culture (Watenpaugh 2004). Hence, in addition to being conquerors, Ottoman emperors also paid great interest to the public construction works. Many of them were undertaken by the state (İnalçık and Quataert 1997). In fact, working on one of the empire's great construction sites was considered an alternative instead joining to the army which proves the parallel structure between organizing warfare and large-scale building projects. In this respect, Ottomans reshaped cities,

build several institutions and monuments as markers of their civilization (Shaw 1976, Watenpaugh 2004). The construction process was started not only for the successive capitals of Bursa, Edirne and Istanbul, but also for provincial centers such as Manisa (Faroqhi 2009). The government strategy was to build sufficient urban environment responding the residents' needs accomplished by means of building complexes called *külliye* surrounded by residential quarters (Kuran 2012).

*Külliye* was the complex of buildings with social, economic, and cultural aim in Islamic architecture. Also the word *imaret* is used instead. In the Ottoman era, either the emperors, viziers or princes' mothers established them on the government lands. The administration of a *külliye* is called as *vakıf* (pious foundation), its regulations and charter as *vakfiye* and their trustees as *mütevelli* (Ödekan 1997). In each provincial capital, there was a state architect working with the local masters. All the expenses, covering the salaries of the staff, were met by the pious foundations, i.e., the *imaret* tradition derived from the Islamic *wakf* context. Therefore, establishment of the *külliye* were very dependent on the Ottoman pious foundations (Kuran 2012).

At the center of any *külliye*, there was a mosque. Other than the mosque, the most crucial component of a *külliye* was the madrasah(s) starting from the 14th century, (Kuran 2012) where education was done free of a tuition fee and civil servants were educated. Other than those, it was possible to be housing other institutional elements as: library, *sıbyan mektebi* (a primary school for teaching Quran to children), *tabhane* (a soup-kitchen offering food to poor), *dariüşşifa* or *bimarhane* (a clinic serving for health facilities). Besides, there were profit-earning based ones comprising khans, shops, bazaar, *bedesten*(s) (covered market), bathhouse(s) (Cezar 1983). Basically, the profit-earning based ones were built upon raising funds based on commercial activities for institutional facilities of the pious foundations (Uluengin et al. 2014). Starting from the 1500s, Ottoman Empire was in the period of expansion in which there was a big increase in the number of *külliyes* (Cezar 1983). Besides, the new *külliyes* by the Ottoman pious foundation system were also found as impressive representations of Ottoman economic and politic power.

New constructions by the pious foundations were established generally at some distance from the old town in where there existed enough space for the monumental buildings and their open and semi-open areas (İnalçık and Quataert 1997). The *külliye* concept played an important role in the establishment of Ottoman urban image by its

dominance in the skyline of the due to the buildings' monumentality, and also the physical position in the hearth of the city (Uluengin et al. 2014).

### 2.2.3. Shaping the Commercial Core of the Ottoman City

The Ottoman cities were clustered around main commercial area, mosques and the citadel. There is not any pure or simple model for the physical description of a typical Ottoman city center, in which there is neither a single square nor certain borders (Cerasi 1999). Accordingly, there was not a single landmark for the center of an Ottoman city, it was generally around some symbolic structures, generally those of *külliyes*. The structure of the city shaped around several parameters: (i) *çarşı* was located in a central part of the city, (ii) mosques by pious foundations were built next to the *çarşı*, (iii) all the main roads opened to the *çarşı*, and (iv) *çarşı* consisted of several buildings serving to commercial facilities, which mostly belonged to the pious foundations (Cezar 1983). As a consequence, the core of the cities shaped specifically around the *çarşı* quarter (Özdeş 1953, İnalçık and Quataert 1997), *çarşı* was not just a physically existing quarter, but it is also an integrity of functions and institutions. Besides, it indicated more values other than productivity and economy based ones as it was a critical meeting point for traders, artisans and inhabitants (Cerasi 1999). Consequently, Anatolian cities assumed a Turkish character not only by the inhabitants but also the construction process of buildings serving to commercial facilities. Cezar (1983) classifies the commercial buildings in the Ottoman era into three: (a) shops, (b) khans, and (c) *bedestens*, from 15<sup>th</sup> century onwards to industrial revolution. To begin with, shops are the members of *çarşı*, which smallest in size but greatest in number. They are generally one floored, and timber structures. They allow the space to gather light from single direction. From the 16<sup>th</sup> century onward, they were members of *külliyes* or within the borders of them (Cerasi 1999). There exist two other variations of them: first, as a double row of shops with the name of *arasta*, and the second, the embodied form in khans or *bedestens* (Cezar 1983). The second group, i.e., khans were providing space for manufacturing, storage and business facilities, and they were significant members of the city center. They were either masonry or wooden structures, with an inner courtyard and a colonnaded portico (see section 2.4.1 for more information on khans). The last group of *bedestens* starts to appear within the cities after

the Anatolian principalities which were used to store valued goods. The spaces of a *bedesten* are spanned either with vaults or domes. They were generally in very central locations. It was quite common to have juxtaposing shop rows (Cerasi 1999). The number of *bedestens* in a city were limited to one or two, dependent on the scale of the city (Cezar 1983).

Correspondingly, the Ottoman city center was not the sum of coincidentally formed spaces or buildings. Along its history, an Ottoman city center had an urban character including *bedesten(s)*, khans and other surrounding shops. This picturesque physiognomy of the commercial center remained unchanged until the effects of industrial revolution (Kuban 2007). Besides, they were all new in shape with both their material and design culture. Nevertheless, the Ottoman city of all periods had a spatial system of “repetition” and “articulation”, it was also quite important for the “Ottomanization” process. The growth of *çarşı* was not in whole but in parts, correspondingly, the city centers’ developments were in parallel and limited to the togetherness of building complexes (Cerasi 1999). Particularly, khans affected the appearance of the city center following the construction of mosque(s) and madrasah(s). Correspondingly, architectural characteristics and their roles enhanced city centers and lead to a balanced functional harmony (Cezar 1983). In the *çarşı* quarter, where commercial and social buildings were located together, main road(s) were surrounded by khans and shops providing a reputation of continuous arches, domes, vaults and chimneys in the city centers perception (Cerasi 1999).

### **2.3. The Image of the Sanjak of *Saruhan* (Manisa)**

Ottomans became more powerful in a hundred-year time, and they established a loose politic lordship in Anatolia. The Ottoman success of expansion proves the ability of the royal family in strategic management of power. In the period of expansion, the Ottoman state developed new administrative places in Anatolia. These administrative units were called *eyalet* or *iyale*, and each was representing a province within the Empire. Sanjaks (*sancak* or *liva*) were administrative zones (Şahin 2009) shaping the core of the Ottoman administrative system (İnalçık 1995, Ortaylı 2008). A typical governmental strategy of the Ottoman Empire was to convert political centers of Anatolian principalities into sanjak following conquest of new territories (Quataert



2005). In this system, local leaders of the preceding Anatolian principalities also accepted the status of being dependent to the Ottoman Empire and acknowledged the emperor as the superior. Nevertheless, the transformation from tributary status and total annexation into the Ottoman system varied according to the circumstances of each territory (İnalçık and Quataert 1997). As a result, the Anatolian principalities transitioned from tribute status and were annexed to the Ottoman State by being registered as sanjak. Consequently, *Anadolu Eyaleti* (Anatolia Province) was founded in 1393/793<sup>4</sup> as an outcome of rapid expansion of the Ottoman State. On the other hand, after the establishment of the direct control over Anatolia, the strategy was to use economic advantage of those conquered zones as much as possible. In order to do that, Ottoman officials carried out many surveys for recording the taxable sources (Quataert 2005). This was a crucial requirement of the *Timar* application, any changes of economic revenues were statistically and systematically recorded in books called *Tahrir* (book-keeping) following critical changes in the state, e.g., conquest of new places, change of throne. That book-keeping system was highly complicated and developed in terms of principles, method and precision compared to the ones of the 15<sup>th</sup> century Europe. Correspondingly, those *Tahrir* books are amongst the primary sources for understanding the administrative economy (İnalçık 2015). Thanks to the records in the *Tahrir* book called *166 Numaralı Muhasebe-i Vilayet-i Anadolu Defteri (937/1530) Anadolu Eyaleti* (Figure 9 ) was composed of eight *liva*: *Hudavendigâr, Biga, Karesi, Saruhan* (Figure 5), *Aydın, Menteşe, Teke, Ala-iye*.

---

<sup>4</sup> Throughout the chapter, (calculated) date in Gregorian calendar is represented in the first segment, and the date in Islamic calendar that are coming from the original texts in the second segment.

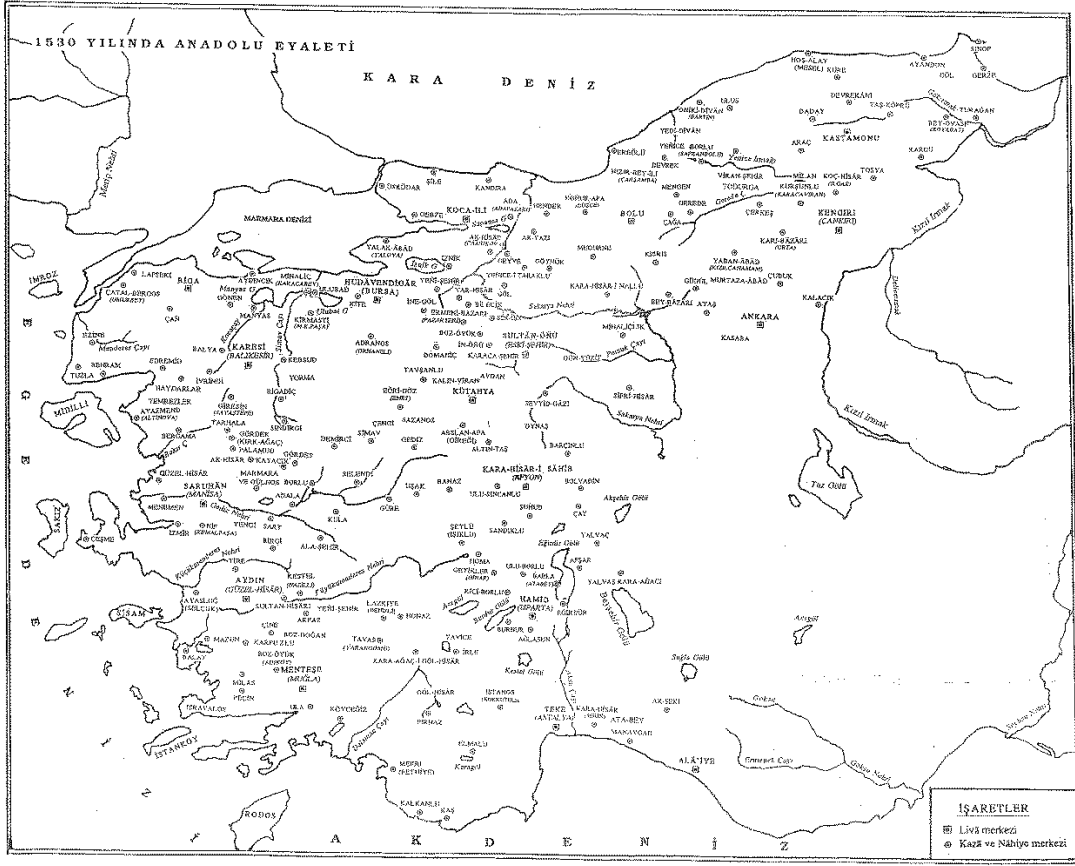

Figure 9. Map of Anatolia Province in 1530  
(Source: 166 Numaralı Muhasebe-i Vilayet-i Anadolu Defteri).

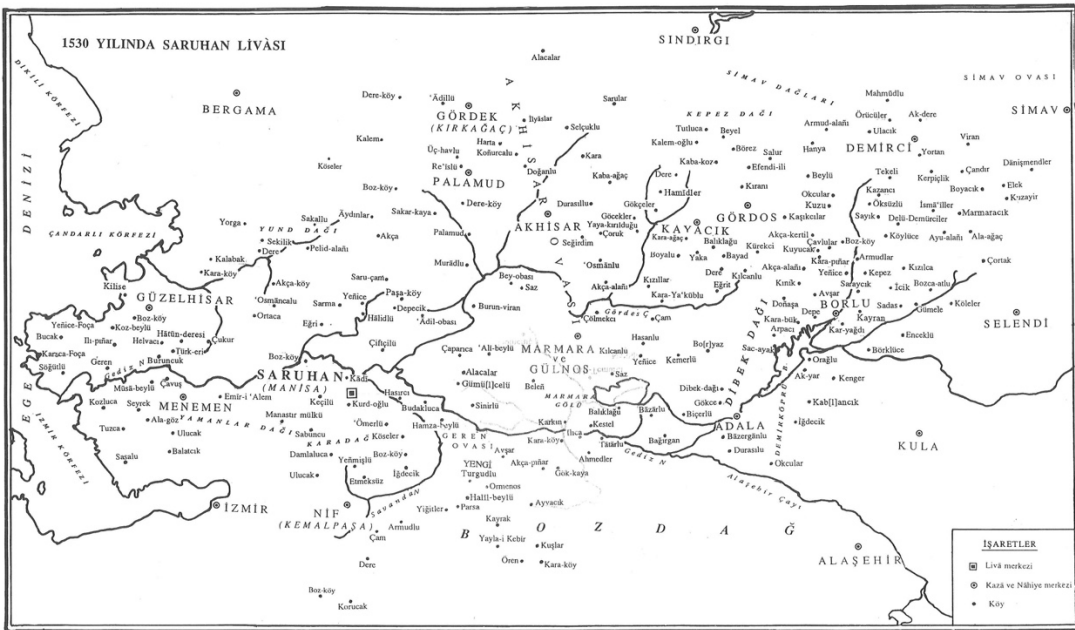

Figure 10. Map of Sanjak of Saruhan (Manisa) in 1530  
(Source: 166 Numaralı Muhasebe-i Vilayet-i Anadolu Defteri).

Other than those, following central Asian tradition, the emperors sent their sons to the provinces for them to gain administrative experience in some circumstances. There, they were accompanied by their *lalas* (retinues and tutors) taking military and political education (Quataert 2005). Consequently, *Saruhan* (Manisa) was converted into a sanjak city, ruled by Ottoman princes (Uluçay and Gökçen 1939). Besides, Manisa was strategically important because of being the closest princely post to Empire's capital, Istanbul as well as being the first place where the Ottoman princes were sent (Pierce 1993). As a result of these circumstances and political importance, it had been a quite important sanjak. This character also supported Sanjak of *Saruhan* (Manisa) to develop advanced physical characteristics not only by its citadel, but also its city center consisting of many public buildings (Quataert 2005). Accordingly, it benefited much from these construction traditions and governmental strategies starting from the end of 1400s until the start of the 1600s as a princely town. The *Küllüye of Hatuniye*, dating to 1490, was the very first example in the Ottoman era, trying to create a new center for the princely town. It was located in the Southern part of the citadel not very far from the old center. The name derived from the female endowment coming from the imperial family, *Hüsnişah Khatun*, the mother of the Ottoman prince, *Şehinşah* (Emecen 2003). On the other hand, it was a traditional practice of sending prince's mother with him to his provincial town. Besides, it was a privilege for prince's mother to adorn the provincial capital with new monuments. She received great amounts of monthly stipend from the imperial budget, the highest rate including princes' (Pierce 1993). Moreover, in Ottoman history, it is quite clear that wives, mothers and daughters, i.e., the female members of the imperial family and other leading families, were playing a role on politics and economics not only by the marriage institution but also through the charities and pious foundations (Quataert 2005).

Furthermore, the *Küllüye of Hatuniye*, by the endowment of *Hüsnişah Khatun*, was the first attempt in order to create a commercial center with its profit-earning buildings, i.e., khan, bathhouses and shops. This process has continued with the construction of the close-by quarters, and has been the primary step to shape not only the commercial hearth of the city but also physical structure of the Ottoman city of Manisa. Accordingly, the reshaping process of the city continued with monumental constructions by large pious foundation during 16<sup>th</sup> century (Figure 11), i.e., *Küllüye of Sultaniye* in 1522 which has again a female endowment, i.e., *Hafsa Khatun*, then,

*Külliye of Hüsrev Aga in 1554, Külliye of Dilşikar Khatun in 1579, and Külliye of Muradiye in 1583 (Emecen 2003).*

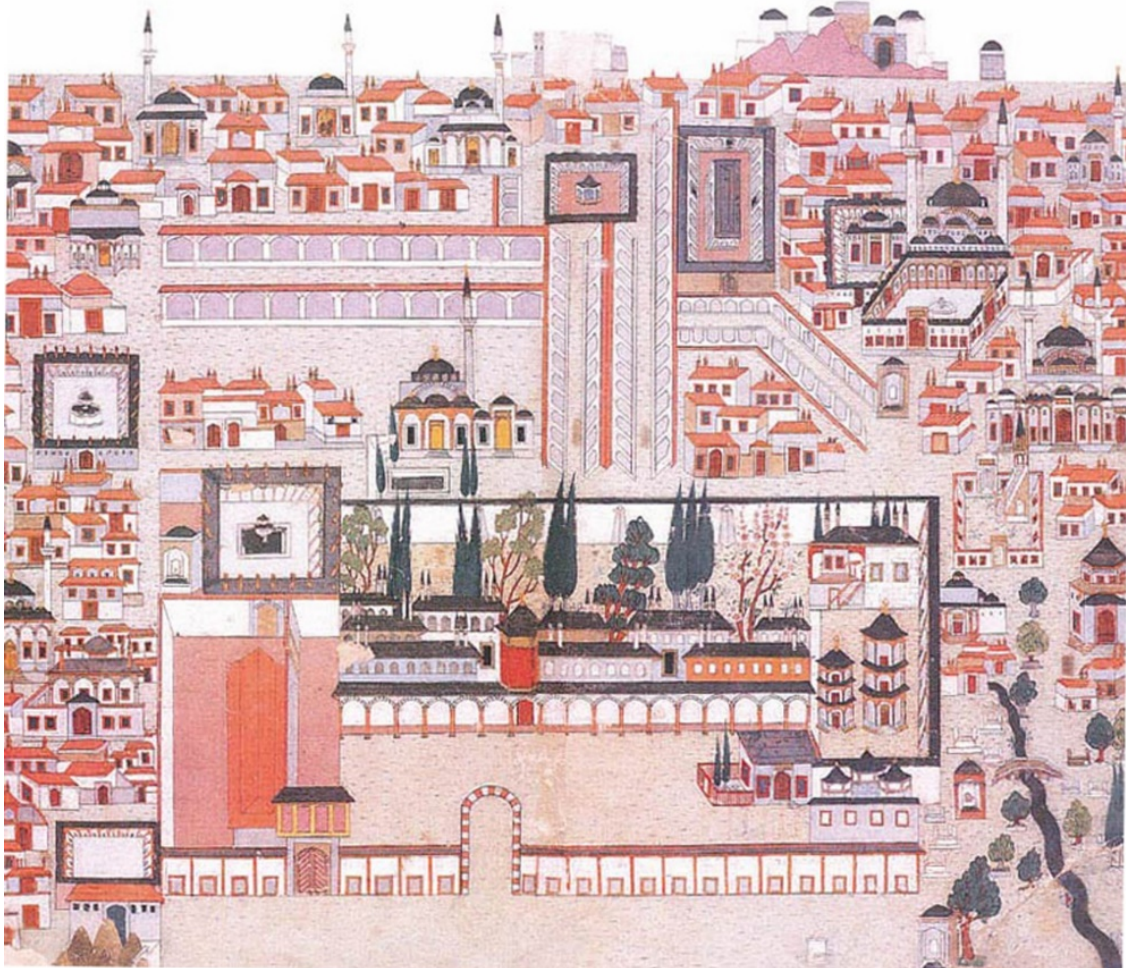

Figure 11. View of Manisa in the late 16<sup>th</sup> century. In the center is the princely palace, the mosque of *Hüsnüşah Khatun* lies just above, while the mosque of *Külliye of Sultaniye*, with two minarets and an outdoor prayer courtyard, lies slightly below the larger mosque of *Külliye of Muradiye* in the upper right. (Source: Pierce 1993, Image Courtesy, Topkapı Palace Museum Library, Istanbul).

### 2.3.1. The Commercial Activities in Manisa

In general, Ottoman production and commercial system was following the regular medieval town mechanism. In that mechanism, production was primarily for the provincial centers and its villages, i.e., for the population inside a province. Accordingly, there was limited production and commerce (İnalçık 2015). Nevertheless, Western Anatolia was the Ottoman territory mostly involved in the commercial activities with Europe (Pamuk 2015). That is to say, Western Anatolia was acting like a bridge for transporting goods from Central Anatolia to Europe. If the map of the Western Anatolia were evaluated, one could easily distinguish radial routes opening to harbors of the Aegean Sea, which were reached from important centers of the period, e.g., Tire (Armağan 2005), Manisa, Aydın (Emecen 1997, Eldem et al. 2012). Hence, the Ottoman State offered commercial privileges for European merchants and ships for them to be included in the economic activities within the Empire, offering the freedom of travelling within the state, changing goods and payment of lower taxes. In the 14<sup>th</sup> and 15<sup>th</sup> century, Venice, Genoa and Florence were amongst the privileged kingdoms. Commercial activities with Europe were based on exporting cereal, leather goods, raw silk and silk loom and other textile products, and importing silk and woolen loom, and other luxury goods (Pamuk 2015).

As a consequence of the above mentioned points, Manisa was involved not only domestic, but also in international commercial activities at the end of the 15<sup>th</sup> century, thanks to its geographical location at the intersection of many important trade routes. Thus, located in the valley of *Gediz* (Hermus), it was serving as a node of the trade routes opening both to Istanbul and the Aegean Sea for the oversea transportation (Uluçay 1942). More specifically, in the beginning of the 16<sup>th</sup> century, both the route connecting Bursa to the harbors of Alexandria, Tripoli and Damascus, and Western Anatolian route reaching to Antalya for exporting the goods were passing from Manisa (Figure 12), following Bursa, which was amongst important commercial and craftsmanship cities of the Middle East (İnalçık 2015), and İstanbul (Emecen 2013). Therefore, the city was involved in international economic interactions between especially Venetian, Greek and Persian traders. In addition, the records of legal administration for different facilities such as taxes, death records, etc. prove that both traders from Central Anatolia and Persian were using the routes passing by Manisa

(Uluçay 1942). Evliya Çelebi's travel records also prove the existence of the Persian traders in the area in the 17<sup>th</sup> century (Dağlı and Kahraman 2007). Moreover, Arab camel drivers, who were offering transportation of the heavy loads for cheap costs, performed commercial transport, not only around İstanbul, but also in Western Anatolian sanjaks, including Manisa (İnalçık and Quataert 1997). Starting with the 17<sup>th</sup> century, İzmir started playing an important role in commercial activities, and it acted as a crucial node for international trade. At the same period, handloom weaving activities weakened in Manisa, and raw materials like cotton and wool were bought by Levantine merchants for high prices.

The non-Muslim merchants of the Empire were playing a critical role in the commercial activities by constructing relations with European merchants and also solving local issues related to collecting of import goods or distribution of export goods (Pamuk 2015). In Manisa, there was only the Jewish community as the non-Muslim population (Emecen 1997) beginning with the 15<sup>th</sup> century, played an important role between Ottoman Empire and Western Europe (İnalçık 2015). It is known that some of them had been living there since the Byzantine times while most of them had been settled following the expulsion of Jews by the Tribunal of the Holy Office of the Inquisition at the end of 15<sup>th</sup> century. Besides, a significant number of Jews manufacturing the woolens, state-*çuha* and *velençe*, migrated from *Salonika* (Thessaloniki) at the end of 16<sup>th</sup> century with the motivations of avoiding increased taxes there, and reaching cheap raw supplies around Manisa. As a consequence, the tax-records prove the activity of Jewish community in commerce after 1531. Nevertheless, until 1660s they were not settled in a specific quarter, their accommodation was mostly in the rooms of khans (Emecen 2013). Besides, due to the commercial advances, a large part of the Jewish community migrated to İzmir in 17<sup>th</sup> century.

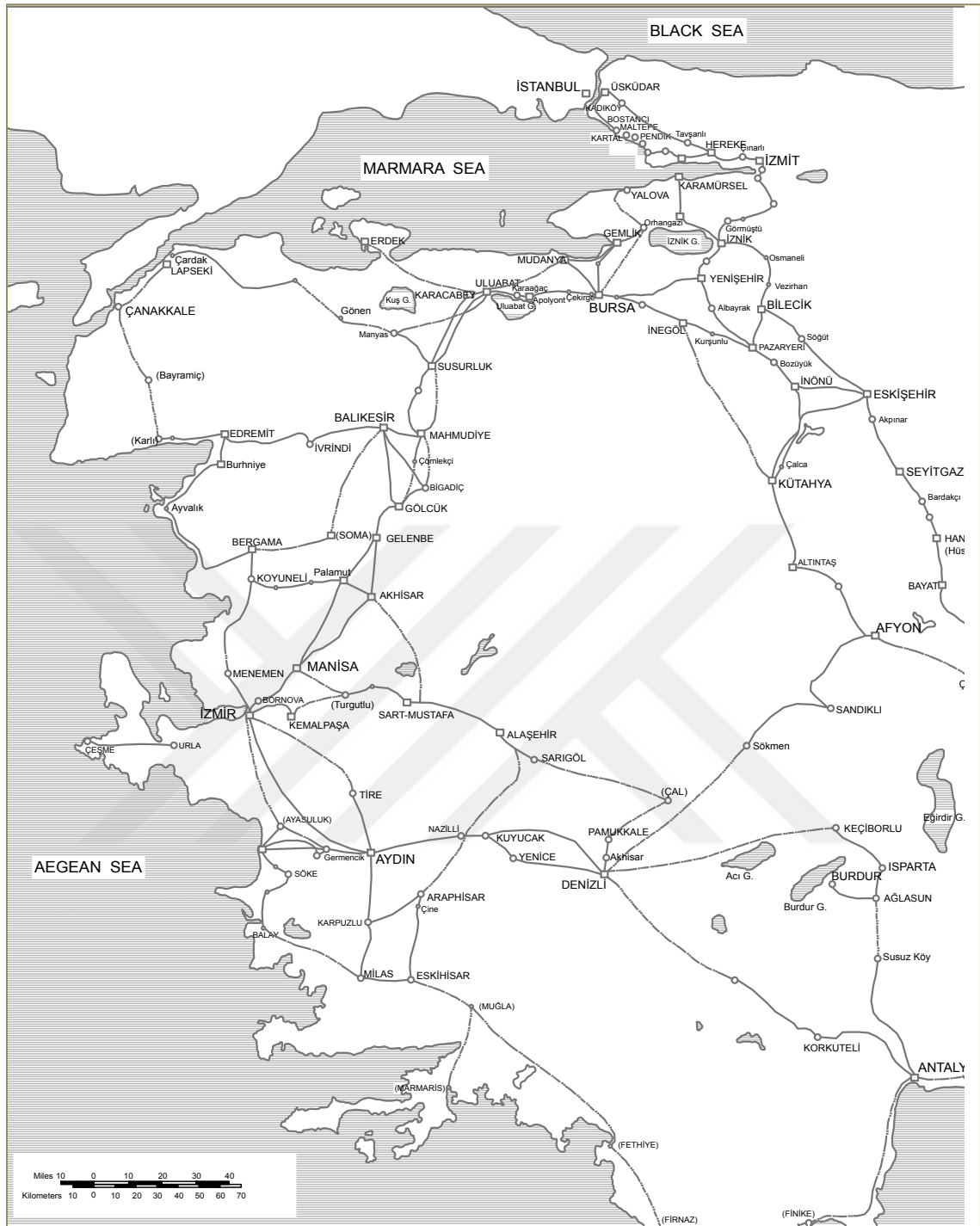

Figure 12. Historical trade network of Western Anatolia from 1550s to 1750s (Image is re-drawn on the basis of the map by Luther 1989).

Each center of the Ottoman provinces was strongly dependent with its rural areas (Kıray 1972, Cerasi 1999). Besides, cotton weaving was an important economy for the Ottoman Empire, and Manisa (Figure 13 and Figure 14) had a leading economy in the production of cotton, and cotton textiles. The raw cotton and cotton textiles produced here were not only spread in the state but also exported (Genç 2014). Records of the 17<sup>th</sup> century show that the provinces of *Aydın* and *Saruhan* in Western Anatolia had been required to deliver huge amount of lining cloth (22,000 bales, equal to 44,000 pieces), of lining for the *yeniçeri* (janissaries) which also proves the characteristic production in the area (Faroqhi 2009). In addition to woolens, cotton textiles, which were also demanded by the Ottoman army and navy as sailcloth were also delivered. Tournefert (Yerasimos 2005) states that in 1702 the most important trade was based on cotton.

At the beginning of the 17<sup>th</sup> century, Manisa was highly affected by the decrease of the Ottoman power on Western Europe. In addition, the development of İzmir, had dramatically changed other Western Anatolian towns' administrative and commercial mechanisms. At the same period, most of the merchants, and commercially active non-Muslim community had started to move into İzmir (Eldem et al. 2012). In 1617, the Ottoman Empire published an order prohibiting the relocation of the Jewish community, who was not only involved in commerce but also worked as tax collectors, from Manisa to İzmir. (Eldem et al. 2012). Nonetheless, as a record of the 1627 shows, the commercial activities of sanjak of *Saruhan* (Manisa) had decreased, and the town started to serve as a barley storage with the effects of the economic crisis of the Ottoman Empire in the 17<sup>th</sup> century (Emecen 2013). In 1811, the administrative sanjak of İzmir was replaced from *Saruhan* to *Aydın* (Kıray 1972) as a result of the new economic structure.

Nevertheless, if different historic information of different centuries is deciphered, one can easily find out that Manisa carried its importance until 20<sup>th</sup> century. As another proof, the rail network in the beginning of the century can also be overlapped with the telegraph network of 1874 (Figure 15). In the telegraph network, the full black dots are stations capable of international transmissions, while half black, half white dots are only available for domestic use. Besides, the thick black lines are international, the thin ones are domestic (Danforth 2013). And one can easily distinguish Manisa still being an international center. Besides, it was a node in the initial rail network (Figure 16) of the empire.





Figure 13. View of Manisa in 17<sup>th</sup> century  
(Source: Peeters 1685).



Figure 14. The engraving of Tournefort describing Manisa in 18<sup>th</sup> century  
(Source: Yerasimos 2005).



Figure 15. The map of Ottoman telegraph network in 1874  
(Source Danforth 2013, image courtesy Atatürk Library, DSCN5503 and DSCN5504).

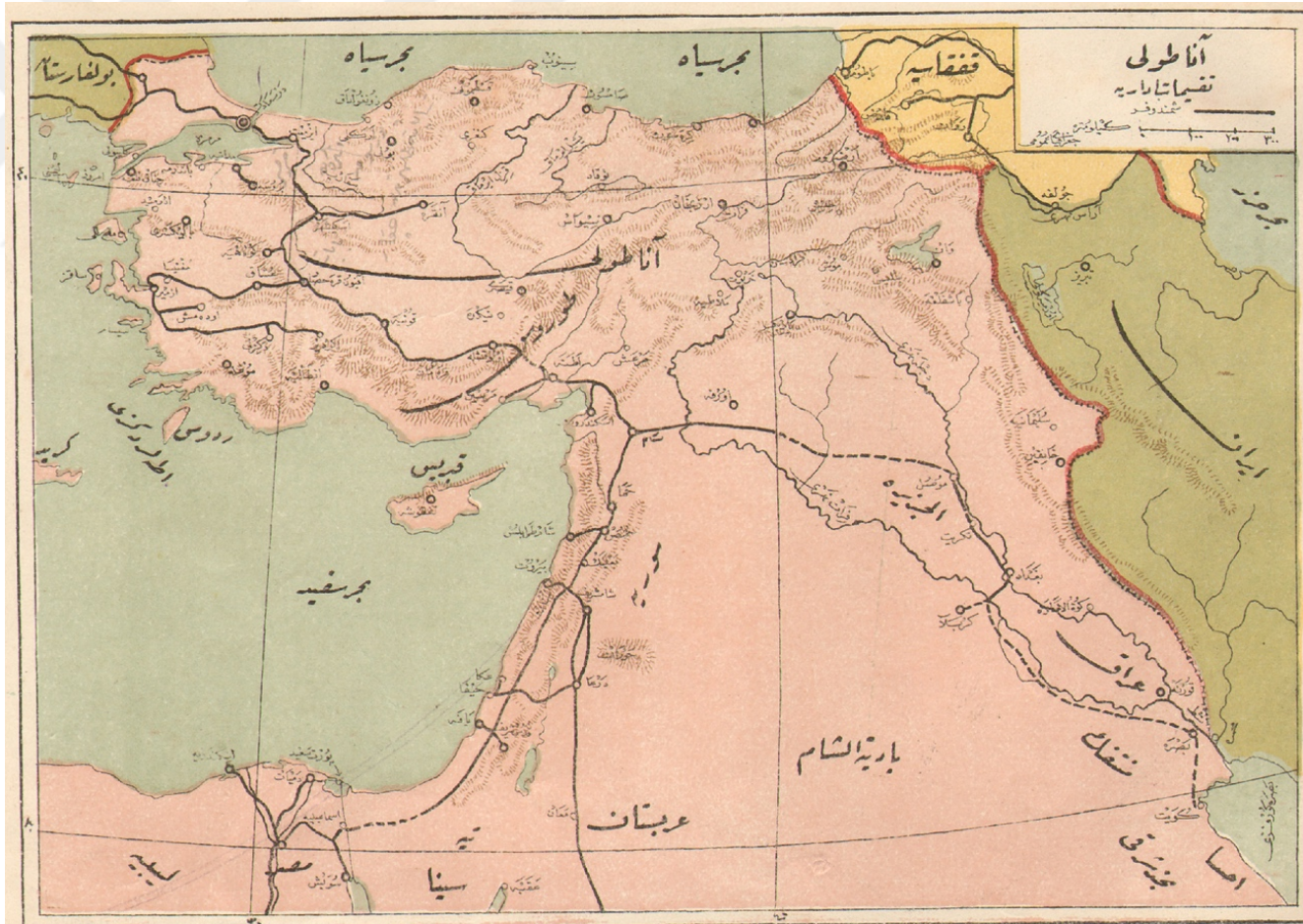

Figure 16. The Map of Ottoman rail network on the eve of World War I (Source Danforth 2013, image courtesy Atatürk Library, Htr\_Gec\_00063).

### 2.3.2. The Commercial Center of Manisa

Most of the *külliyes* and the related profit-earning units of the pious foundations were built in 1500s, when there was a growth in the transport of goods to İstanbul. This process allowed Manisa to shape its commercial core and *çarşı* quarter as well. But, it should be noted that prior to that, during the *Saruhan* Principality, a *çarşı* quarter was in existence which should had been more premature. This is stated in one of the Ottoman court records belonging to the *Hoşkadem Paşa* pious foundation. Besides, at the same period, there was a *bezzazlar çarşısı* (drapers' bazaar) in Manisa. However, today there is no information or trace on its spatial characteristics (Uluçay 1946).

In the Ottoman era, different artisans or merchant guilds were clustered on different streets (Kuban 2007). Accordingly, the commercial center was zoned with respect to the type of good. In Manisa, planimetrically, shops and *arastas* housing different guilds were almost in orthogonal scheme: parallel or vertical to each other. At the very end of the *Çarşı* Quarter, there was an open area with an open-air bazaar (Uluçay 1942). The cities with special status like Manisa had more improved city centers than others (Cerasi 1999). After the construction process of khans and shops in the center, the artisans and craftsmen were obliged to move to shops within there, by this way, the pious foundations could benefit from the economic growth by means of rental income. Besides, these buildings, as valuable commercial real-estate, enhanced the appearance of those specific towns. In time, many of these structures served traders rather than craftsmen, their presence transformed the overall character of the city centers which had attracted craftsmen into the relevant neighborhoods more (Faroqhi 2009). Within the light of some records of legal administration dating to 1531 and 1575, Emecen (2013) classified artisans and traders into four main groups: (i) the ones based on food-making, (ii) the ones based on cotton, especially handloom weaving, (iii) leatherworks and related productions including dyeing, and (iv) tool production and foremanship. Hence, the two big income source for the inhabitants were based on textile, the handloom weaving and leatherworking. Accordingly, dyeing was quite improved. The open-air bazaar was held in *Tahtakele*, *Çarşı* and *Karaköy* quarters once a week, and the goods sold in that bazaar were including grape-based products, soaps, wheat, cereal, fruits, salt and fish (Uluçay 1942).

Evliya Çelebi in his travel records dating 1671 (Dağlı and Kahraman 2007) states that Manisa was a large city settled on the Northern plain of the *Sipil* (Sipylus) Mountain consisting of the palace and 60 quarters housing 6600 houses, big khans, 3360 shops, a bedesten, a saddlery and a shoe market. Moreover, *Evliya Çelebi* had described that the Manisa commercial center's, i.e., *Çarşı* Quarter's, boundaries as the following: from *Hatuniye* Mosque to *Alaca* Bathhouse in the direction from North to South, and from *Kurşunlu* Khan to *Ali Ağa* Mosque in the direction from East to West (Uluçay 1942). In addition to that, there were shops around the neighborhood called *Tahtakale*. The boundaries were limited to *Sultan* Bathhouse, *Hatuniye* Mosque, and *Çeşnigir* Mosque.

More specifically to the case study, the profit-earning components of the pious foundation of *Hüsnişah Khatun* were as the followings: shops and gardens between *Çeşnigir* and *Hatuniye* Mosques, a bath-house, i.e., *Serabat Hamamı*, two mills, some farming lands in the villages of *Selendi*, *Kaşıkçı* and *Seyis*, a big khan, i.e., *Kurşunlu* Khan with its 21 shops, and a land at its Southern part (Gökçen 1946, Süllü 2010 quoted from the translation records in the Archives of National Directorate General of Foundations).

#### **2.4. The Case Study: *Kurşunlu* Khan in Manisa**

*Kurşunlu* Khan, which is the subject of this research, is one of the Ottoman city khans located in the historic commercial center of Manisa. *Kurşunlu* Khan with the land registry of 43-360-19 is a listed-building by the decision number 348 of the Izmir Number 1 Regional Conservation Council of Cultural and Natural Wealth on June 2, 1988. Besides, it was included in the urban area registered in the conservation aimed development plan approved by the decision number 1674 by the Izmir Number 2 Regional Conservation Council of Cultural and Natural Wealth on May 26, 2004 (Süllü 2010).

The khan was built in order to raise fund for the *Külliye of Hatuniye* in 1497-98 as some scholars (Uluçay-Gökçen 1939, Oğuz 1974) point out. Nevertheless, the precise construction date of *Kurşunlu* Khan cannot be reached as the khan does not have an inscription panel itself. *Hatuniye* Mosque, which is thought to belong to the same *Külliye*, was just next to the grand bazaar of Manisa. The inscription panel of *Hatuniye*

Mosque shows the construction date of the mosque as 1490/896. Today, only *Hatuniye* Mosque, *Kurşunlu* Khan and the primary school remain standing from the original *Küllüye* of *Hatuniye*. The trustee for the pious foundation was by Imperial family member *Hüsniüşah* (known also as *Hüsniyeşah* or *Hüsniüşaz*) *Khatun*, who was the wife of the *Sultan Beyazid* II (Acun 1999).

The oldest document belonging to *Kurşunlu* Khan is the charter of the pious foundation (“*Manisa Hasna şaz Hatun binti Abdülcelil Vakfı*”) in Arabic dating 1498/903. Its Turkish translation by Keskinoglu has been one of the primary sources thanks to the art historian Süllü’s report in 2010. In this translation, which describes the original state of the building, it is noted that *Kurşunlu* Khan had 36 rooms on the ground floor and 38 rooms on the first floor, it had a big inner courtyard with a pool in the middle and a big stable at the rear. It is also recorded that it had 21 juxtaposing shops.

Gökçen (1946) who worked extensively on Manisa gave records of the pious foundation of *Kurşunlu* Khan, besides in his work with Uluçay (1939) indicated descriptive information on the building. Besides, Emecen’s study (2013) on 16<sup>th</sup> century Manisa is also an important resource for not only *Kurşunlu* Khan itself but also for the life in the Sanjak of *Saruhan* (Manisa). Nevertheless, it should be pointed out that Emecen (2013) distinctively defines the khan as *Han-ı Cedid* or *Yeni Han* throughout the book. Furthermore, Acun (1999) reports inventory information on the khan within the context of Turkish architecture in Manisa. Moreover, the section of *Kurşunlu* Khan (Yavaş 2002) in the TDV Encyclopedia of Islam examines the building. The article by Oğuz (1974) is also very valuable especially on information about the building’s state before and after the restoration in 1966. There exist also some other records, as secondary sources, in some books (Öney 2002, Yüksel 1983) indicating brief descriptive information on *Kurşunlu* Khan. In addition to the above listed written documents, the vector and raster data in forms of measured drawings, drawings of the restitution phases with their reports, old photographs and scanned documents are collected thanks to the archives of ARK İnşaat.

There are also a few records by travelers who visited the Sanjak of *Saruhan* (Manisa), i.e., Turkish traveler Evliya Çelebi in 17<sup>th</sup> century (Dağlı and Kahraman 2005), and also some international travelers in the Ottoman Era, which enlightens period’s characteristics (Üçel-Aybet 2003). Amongst them, there are Simeon of Poland in 17<sup>th</sup> century (der Andreasyan 1964), Tournefort in 1700s (Yerasimos 2005), Richter

(Pınar 1998) and Chandler both in 19<sup>th</sup> century (Revett 1971), and Riefstahl in the beginning of 20<sup>th</sup> century (Wittek 1931). Nonetheless, only Evliya Çelebi and Riefstahl kept specific records of *Kurşunlu Khan*. Evliya Çelebi had described *Kurşunlu Khan* in 1671 as *Hatuniye Khan* which was used as a cereal bazaar and stated that it was a big khan which had 40 domes, and its roof was covered by lead. In addition, he noted that Persian and foreign merchants were staying in there. Whereas, Riefstahl described *Kurşunlu Khan* as a big, nearly square planned Ottoman city khan. Moreover he showed the khan's location in his sketch plan of the city (Figure 17), and in his photograph (Figure 18), *Hatuniye Mosque* and the surroundings can be seen.

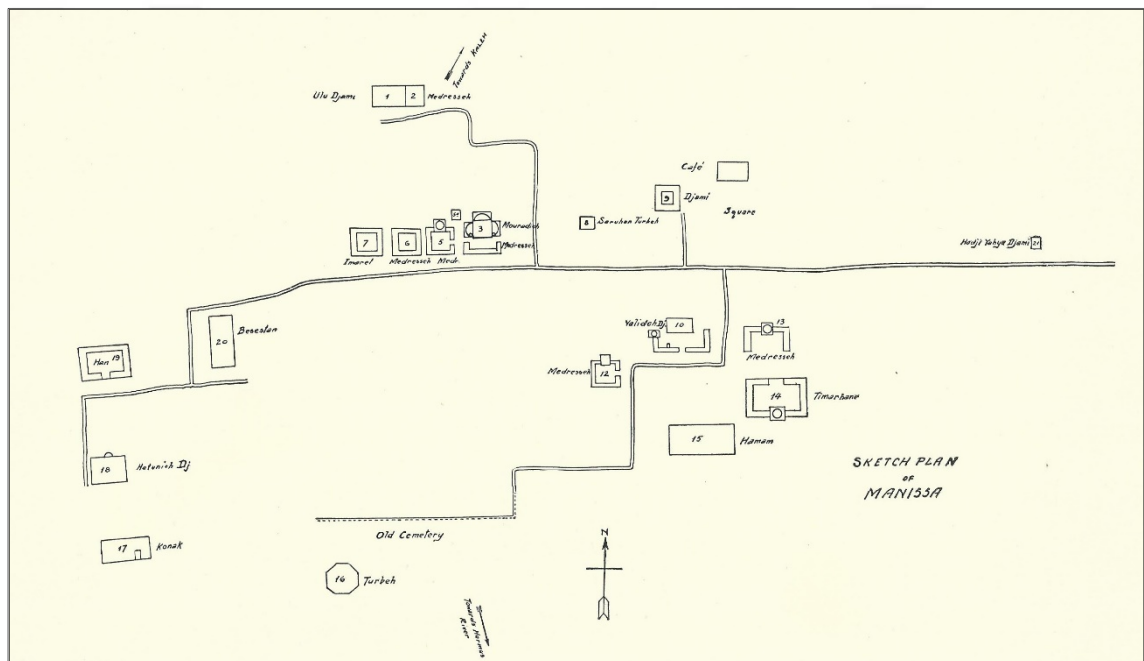

Figure 17. Sketch plan of Manisa. (On the very left hand side there is *Kurşunlu Khan*, the mosque of *Hüsnişah Khatun*, *Hatuniye Mosque*, lies just below, while the main axis follows towards right with other complexes on it.) (Source: Wittek 1931).



Figure 18. View of *Hatuniye* Mosque. *Kurşunlu* Khan's Northern facade can be seen partially on the left hand side. In the background, *Sipil* (Sipylus) Mountain (Source: Wittek 1931).

#### 2.4.1. The Concept of “Khan”

It is possible to describe identical characteristics of the commercial buildings in general regarding the Ottoman era starting from 15<sup>th</sup> century. The khans were among the irrevocable components of the Ottoman city centers which were not only a place for exchanging goods, but also a place for industrial activities with many workshops. In the medieval age, the variation of the building with same function takes different names in different geographies: *caravanserai* in the Middle East, *gasthoff* in Germanic, *inn* in Anglo-Saxon, *hospitium* or *auberge* in Latin and *fondaco* in Geneon and Venetian (Güran 1976).

Güran (1976) puts forward that “khan” typologically derives from the *ribat* in Central Asia which was used primarily to provide safe shelter for traders and travelers, and were composed of a courtyard and colonnaded portico, without any closed space. Throughout the history, those buildings in Turkish Architecture leave their places into



two types of khans: first, *menzil hanları* referring to the khans on trade routes, and second *şehirliçi hanları* referring to the khans located within the cities. Anatolian Seljuk onwards, the latter was also in existence, e.g., Konya *Şekerfurşunlar*, although none could survive up today. In the Ottoman period, due to the advances in urbanization and commerce, the latter was evolved extensively leading to a particular typology. To sum up, *şehirliçi hanları*, like in the example of *Kurşunlu Khan*, are differing from the ones built at the outskirts of the city on trade routes which intend primarily to provide shelter for traders, their animals and goods. Besides, they were built as a part of *külliyes* close or distant to the other components. Hence, they do not reflect any defensive characteristics (İlter 1969, Güran 1976, Ersoy 1991). Moreover, these khans did not only offer accommodation facilities to merchants and travelers for short-term stays, but also allowed commercial facilities within the shops located typically on the ground floor serving as a place of trade.

There also exists a common architectural typology for the *şehirliçi hanları* in the Ottoman Era. They are generally two-storied buildings. The ground floor consisted of storage places, workshops and a stable, whereas the second floor was dedicated for accommodation of the traders. (Yalçınır 1997). They were built in a considerably utilitarian manner. On the contrary to their pure utilitarian geometry and details, which is also found quite monotonous and repetitive, a dynamic and colorful life was going on inside with merchants, artisans, goods, etc. Outer shell of the building is generally in a simple rectangle with some exceptions which are located in dense organic urban patterns. The massive shell contrasts with the more impressive inner courtyard opening to sky which is typically surrounded by a *revak* (colonnaded portico). The use of colonnaded portico is a very common type of representation of the period's architectural style (Kuban 2007). At first sight, one can find it similar to the false impression of colonnaded portico by row of arches used Anatolian Seljuk Caravanserais, however their vaulted galleries are not semi-open circulation areas like in the *şehirliçi hanları* (Tükel Yavuz 1997).

The particular typology with a central courtyard and the use of colonnaded portico remains the same starting from the earliest examples, i.e., *Emir Khan* (1336) in Bursa, to the last examples of the empire (Kuban 2007). The early examples are with a single courtyard. In the later times, there are two or three courtyards for different functions, e.g., one for rooms and one for stable. Very first examples of those can be found around Bursa, as well as in İstanbul. These are the ones dedicated to commerce

(Yalçın, 1997). On the other hand, it should be noted that Ersoy (1991) categorized the Ottoman city khans of İzmir into two: the khans with a courtyard and the khans without a courtyard. Nevertheless, the latter had a few examples, which is similar to *arasta* in rectangular shape with an inner corridor and spaces opening to it. The construction of the extroverted adjacent shop rows was closely related to the possible financial sources of the pious foundations for construction works and the properties of each land (Kuban 2007). If there are shops on the ground floor, they are open to the streets rather than to courtyard (Yalçın 1997). Besides, it is very common in typology to have a central fountain and pool in the courtyard, which is generally multilateral or circular in plan (Ünsal 1959).

They generally have more than one main gate as they are planned more for commercial facilities than the defensive ones, distinguishing from the Seljuk ones (Ünsal 1959). The main gates were organized in two variations: the ones which are on the same level with the belonging facade, and the ones designed as a *taçkapı* (portal) which are slightly shifted outwards. If shops existed, they had large arched openings. The rest of the mass remained windowless in this level of the khan. The inner spaces opening to colonnaded portico had windows and doors. On the contrary to ground floor, each space had a single opening, in a vertical rectangular shape, on the first floor (Ersoy 1991).

Masonry system was applied for the constructions whereas there were rare timber ones that could not survive until today (Kuban 2007). The construction material is either cut-stone or rubble with or without brickworks, whereas inner filling was done by rubble stone. If there was no brickwork used, two types of applications were done: single color or double color stonework. If brickwork was also included, the composite bonding might be either as consecutive stone and brick courses or vertical brick courses along the stonework. This application could easily be recognized on either facades or also on the walls facing colonnaded portico. Moreover, the casings of doors and windows were made of brickwork, stonework or in a composite order (Ersoy 1991). It should be noted that there were slight differences in material culture according to local construction technique and traditions and the material usage, e.g., different stone properties brought from local quarries, bricks gathered from local kilns, etc. For spanning a space, domes were used widely, in addition to vaults and timber roofs. The motivation for the use of domes were based on two parameters: their greater success in load distribution and the lightweight characteristics (Kuban 2007).

## 2.5. Architectural Characteristics of *Kurşunlu Khan*

The most apparent part of a building is its physical structure. Besides, it is not a simple matter of creating a frame, but also they are reflections of material culture of the history (Roth 2007). Each building is a particular example of a physical character which vary according to style and period. The geometric order of *Kurşunlu Khan* derives from the Ottoman style, specifically to the very early examples of the Ottoman classical style.

*Kurşunlu Khan* like the other buildings composing the *Küllüye* of *Hatuniye*, was erected on a nearly flat land in the Quarter of *Serabad*, which is today called Quarter of *Ege*. The *Borsa* Street (also known as *Dr. Sadık Ahmet* Street) lays in between *Hatuniye* Mosque and *Kurşunlu Khan*, which is slightly uphill towards East (Figure 20), It is a two-story building, originally built almost square in plan, circa  $48 \times 51$  meters, with an inner courtyard located in the center, circa  $28 \times 24$  meters in size.

There are 10 large openings facing to *Borsa* Street, and 10 other large openings facing to 1818 Street on the ground floor, which are the display of the shops, i.e., the khan is surrounded by shops on North and West directions (Figure 21). On the contrary, there are neither shops nor their related openings on the other two facades (Figure 22). All the facades unite with arched window openings of the cells on the first floor, which are followed by the lines of small chimneys that add an interesting perception to the exterior. The portal is located on the 1818 Street on the West, which is set slightly to right side of the mass, so it is not exactly on true-axis. Correspondingly, there are 6 openings on the left hand side, whereas there are 5 openings on the other side. The portal is also recognizable on the facade, which is slightly longer in height, and located slightly interior regarding the rest of the facade. The portal opens to a vaulted entrance hall which has two niches on its both sides. There is also another entrance to the khan, on the same axis, at the opposite side from 1300 Street. This entrance is reached by stairs from the street downwards for a level change of circa 5.50 meters.



Figure 19. (a) Aerial image of *Kurşunlu Khan*, viewed from Northwest, (b) and (c) Northern view of *Kurşunlu Khan*, (d) Main entrance on the West facade, (e) Secondary entrance on the East facade. (Source: Saygı 2015).

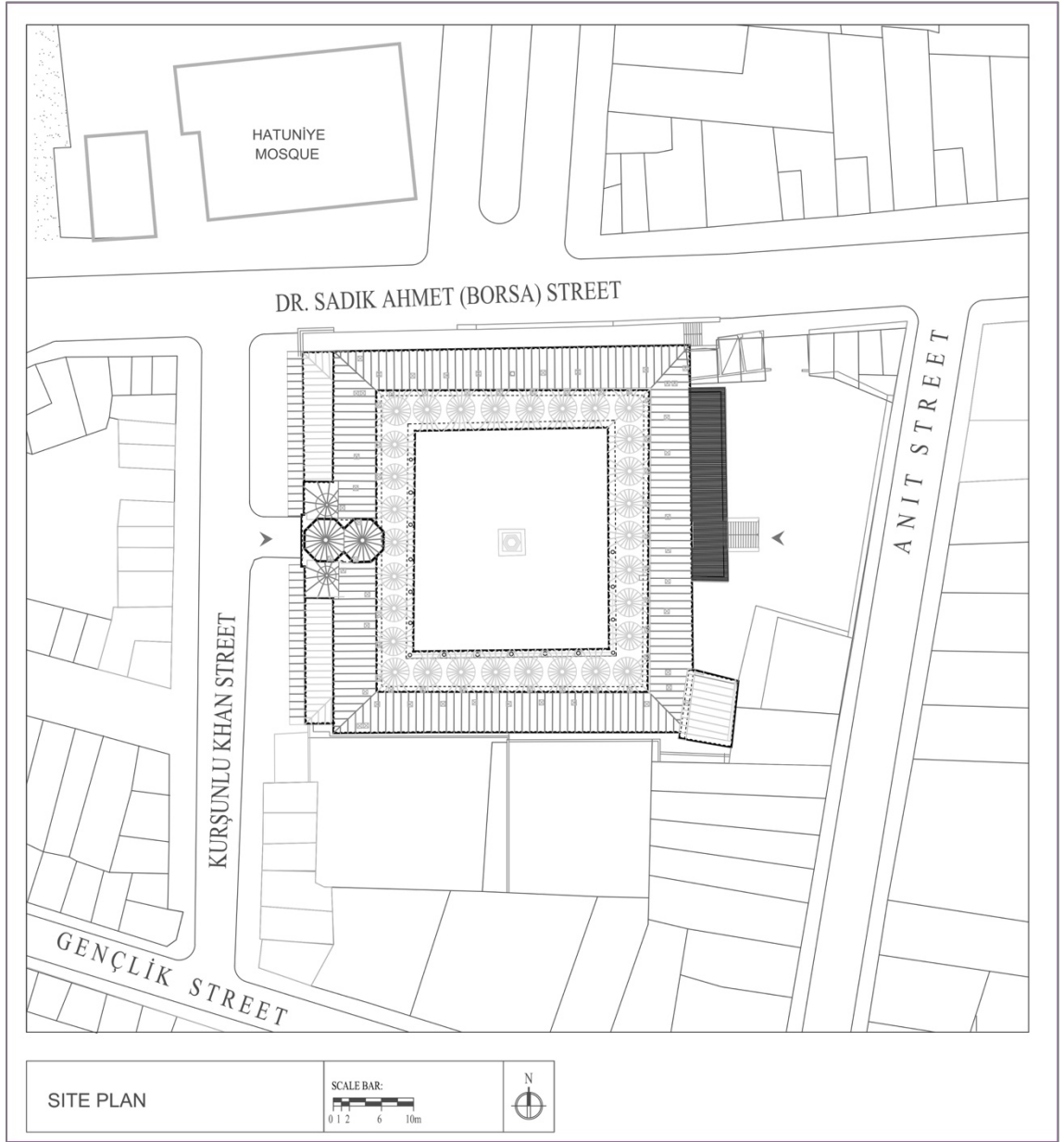

Figure 20. Site Plan of *Kurşunlu Khan* showing as-found state  
(Source: ARK İnşaat 2011).

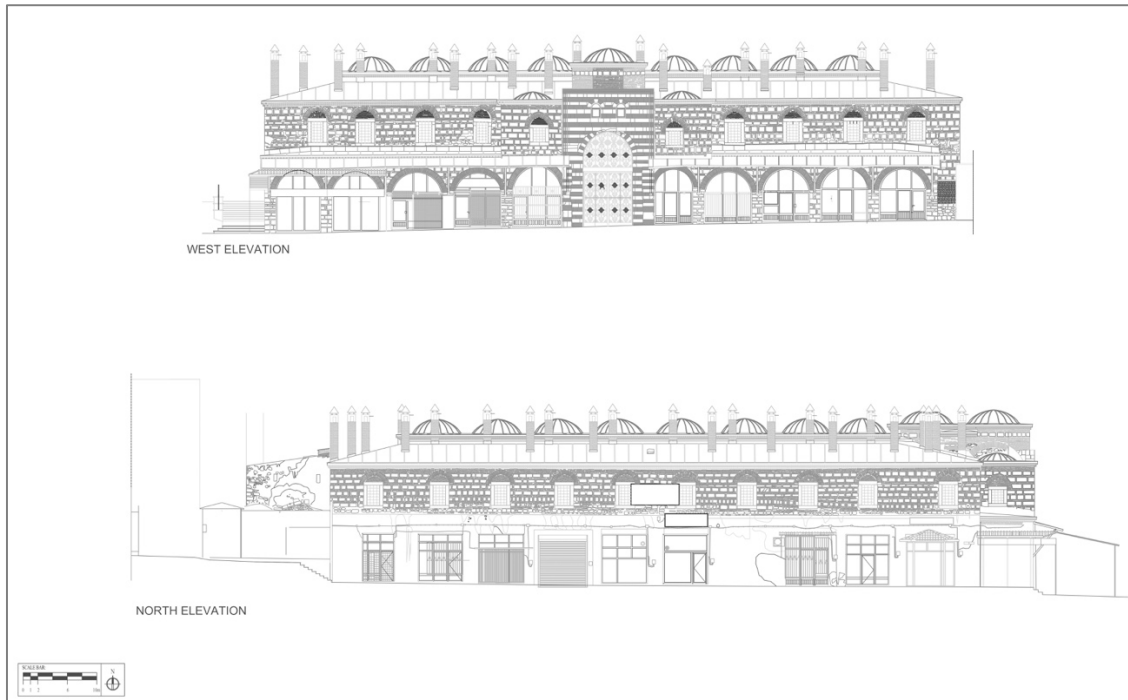

Figure 21. West and North Facades of *Kurşunlu Khan* showing as-found state (Source: ARK İnşaat 2011).

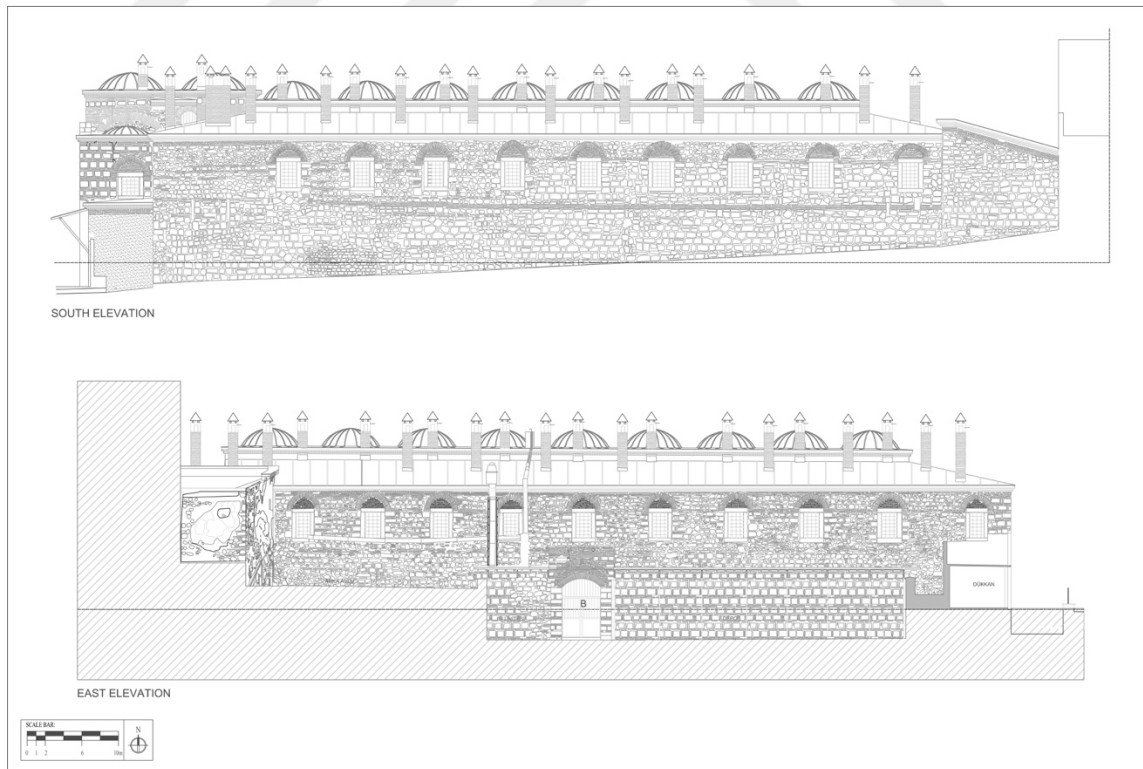

Figure 22. South and East Facades of *Kurşunlu Khan* showing as-found state (Source: ARK İnşaat 2011).

Following the entrance hall, a great courtyard surrounded by a colonnaded portico is found. There are 36 homogenous cells, excluding spaces for entrance hall and the latrine, of the ground floor, opening to the colonnaded portico (Figure 23). All of these cells are repetitive in spatial character. Each of the cells is circa 3.10×3.50 meters in size, and all are rectangular in plan and vaulted. Besides, each of the cells has a window and a door for the spatial connection. The Southeastern corner of the building, as a rectangular mass, is mutilated on the ground floor in order to locate latrines. The portico just in front of them supports the covered gallery in front of the cells of the upper floor. The upper floor can be reached by the stairs located on the left hand side after the great entrance hall. On the first floor, there are 38 homogenous cells, excluding the latrines. Each of the cell is again circa 3.10×3.50 meters in size, and all are rectangular in plan, vaulted spaces. Besides, each of the cells has a door for the spatial connection with the gallery differentiating than the ones located on the ground floor. Moreover, in each, there is a fireplace and one or two niches. The spatial solution for the latrines is exactly repeated as the ones on the ground floor (Figure 24).

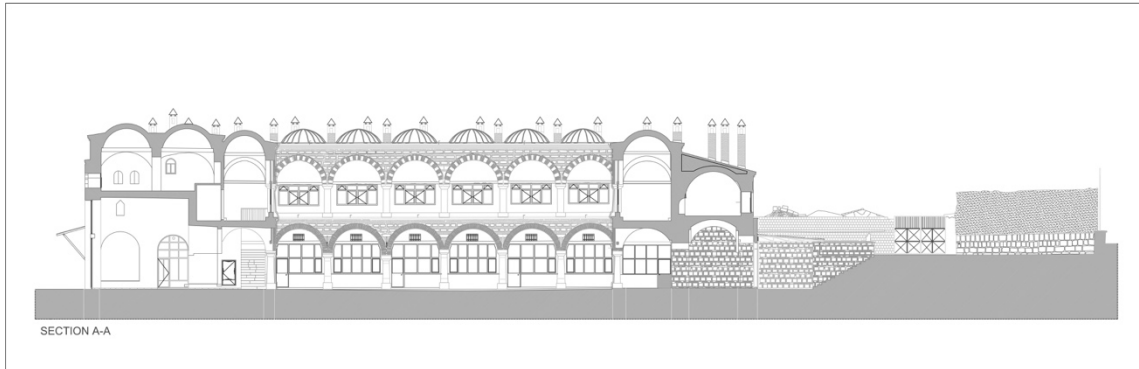

Figure 23. Section of *Kurşunlu Khan* showing as-found state  
(Source: ARK İnşaat 2011).

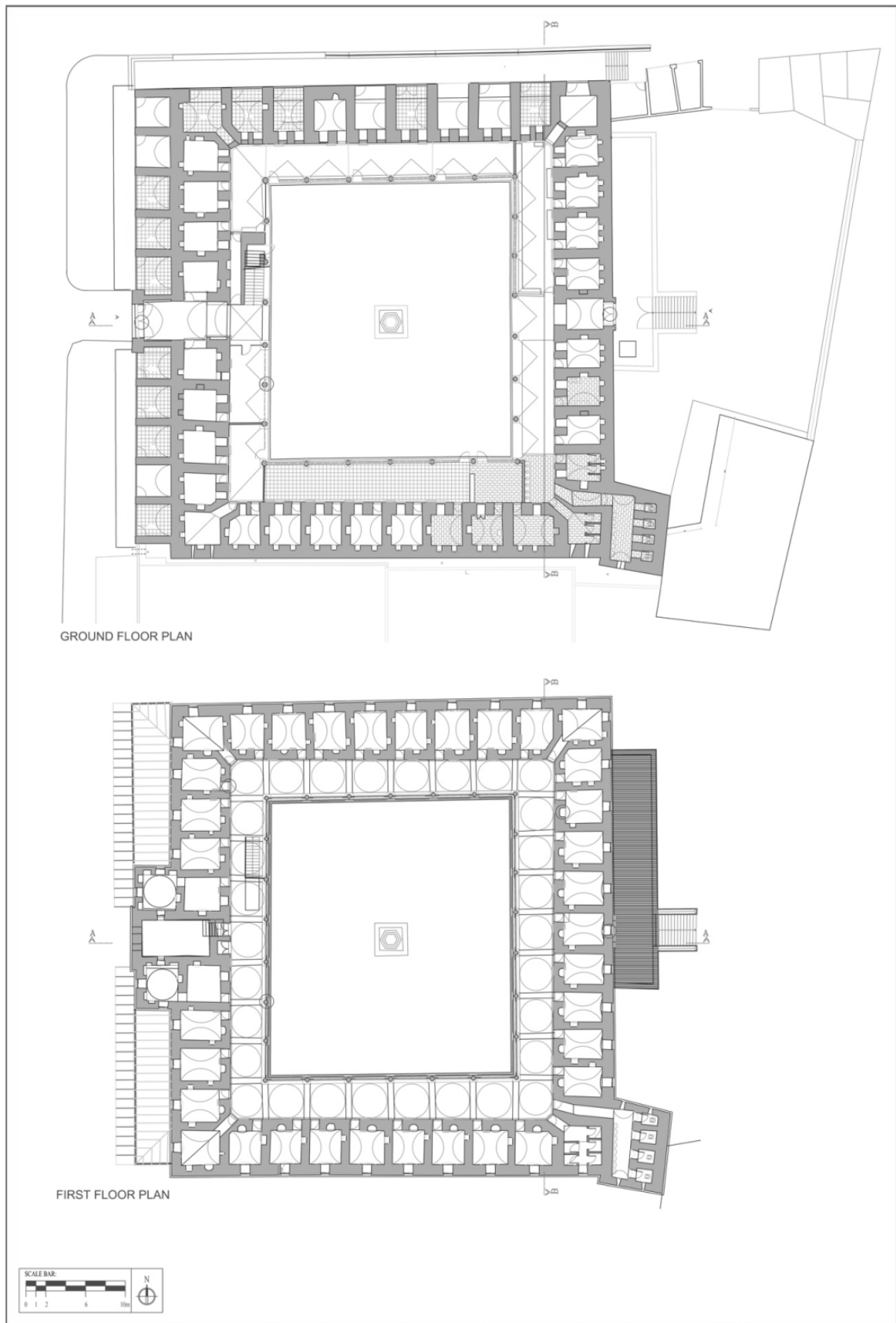

Figure 24. Floor plans of *Kurşunlu Khan* showing as-found state (Source: ARK İnşaat 2011).



The khan is a masonry structure, built of courses of stone with brick layer(s) which is very common for the public building constructions of the era. Though, this character finds two kind of application, excluding the definitely differentiating Western portal. The West and North facades, and the walls of the colonnaded portico facades are built with cut-stone with 2 or 3 layers of brick set in a thick layer of mortar Besides, a vertical brick is placed before each cut-stone. On the contrary, rough-cut stone with layers of brick set in a thick layer of mortar is used for the East and South facades (Figure 25).

The exterior and interior walls which make the vertical structural system together, are the same in character for first and second floors, and 100 to 120 centimeters in thickness. Whereas, other walls that are used for separating the spaces are again in masonry system, but 70 to 80 centimeters in thickness. The elevation of the ground floor is circa 4.50 meters in height, whereas it increases up to 6.65 meters for the ground floor including the height of the domes on the top. The shops located on North and West directions are also built of courses of rough-cut stone with layer(s) of brick set in a thick layer of mortar, circa 70 centimeters in thickness. The openings of those shops are spanned by arches made of brickworks and circa 30 centimeters thick. The upper surface of those shops are made of barrel vaults.

There are 26 columns with a diameter of 50-55 centimeters at the bottom, and 46 centimeters at the top surrounding the portico. A very common way for masonry structures to span the openings by arches is applied for the portico. Several arches are placed end to end in which they are placed on columns that all together forming the colonnade. There are 7 arches on both East and West directions, and 6 arches on both North and South directions. Therefore, there are 26 arches in total. The barrel (also known as tunnel) vaults, which can be visually described as the results of arches pushed through the space, are used for covering the semi-open portico on the top. They are constructed with the courses of brickwork and are 20-25 centimeters at least in thickness. Moreover, the long shaded vaults of the ground floor form attractive perspectives. On the first floor, again the same number of arches placed end to end and series of columns are forming the colonnaded gallery. Differentiating from the ground floor, the diameter of the columns on the first floor are 45-47 centimeters at the bottom, and become 40-50 centimeters at the top. Moreover, domes, which are visually generated based on rotating an arch about its center in vertical axis, are covering the

semi-open space on the top. The domes, which are massive shell of brick courses, are 30 in total number.

There is no interior or exterior ornamentation. The only component representing ornamental characteristic is the portal's facade, where there is a two-color application of white and red cut-stones as horizontal layers (Acun 1999), where the shape of cut stone was nearly perfect in shape (Figure 26).



Figure 25. Partial photo of the North (left hand side) and South (right hand side) facades in which masonry works can be easily distinguished (Source: Saygı 2015).



Figure 26. Photo showing the two-color application of stonework at the main entrance.

## 2.6. Comparative Study

Spatial and physical characteristics of other khan examples of the period are compared with *Kurşunlu Khan* for a better understanding (Table 4).

The volumetric order of *Kurşunlu Khan* consisting two floors almost square in plan with a central courtyard surrounded by a colonnaded portico is similar to *Bey (Emir) Khan* (1336), *Fidan Khan* (1400s), *Geyve Khan* (1400s), *Koza Khan* (1491), all in Bursa; *Pirinç Khan* (1508) in İstanbul, *Yeni Khan* (1543) in Tire and *Taş Khan* (1600s) in Menemen.

It is a later example of the aforementioned building typology than the ones located in Bursa while an earlier example compared to the ones located in the same region. It is also seen that *Kurşunlu Khan* is identical to the other khan examples of the Ottoman period of Beyazıd II, i.e., *Koza Khan* in Bursa, *Pirinç Khan* in İstanbul.

The scale of the mass (48mx51m) is smaller and the number of rooms are less than *Pirinç*, *Koza* and *Fidan Khan* in Bursa, while it is greater than the rest.



The portal is in line with the façade differentiating than *Geyve Khan*, *Koza Khan* in which the portals are recognizable as additional rectangular volumes.

*Kurşunlu Khan* has surrounding shop rows differentiating than Bursa examples, but is similar to Tire examples of *Kutu Khan* (1429), *Çöplüce Khan* (1442), *Ali Efe Khan* (1525), *Bakır Khan* (1543), and *Yeni Khan* (1543).

Cantay (1989) records that there is a certain division of spaces separated to the people and animals in the khans with colonnaded portico, and the space for animals are generally solved as an individual space. *Kurşunlu Khan* has a secondary entrance like *Taş Khan* in Menemen, *Bey (Emir) Khan*, *Fidan Khan*, *Geyve Khan* and *Koza Khan* in Bursa.

The secondary gate of *Kurşunlu Khan* should once be linked to a stable for animals.

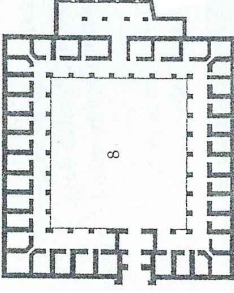
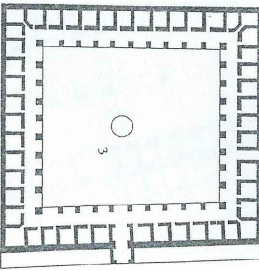
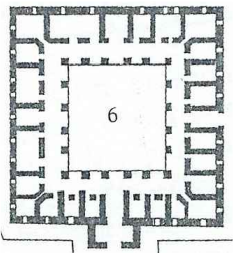
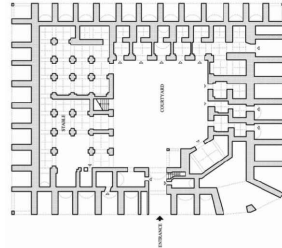
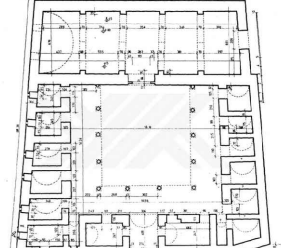
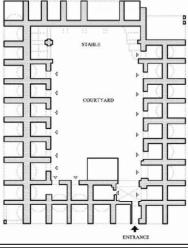
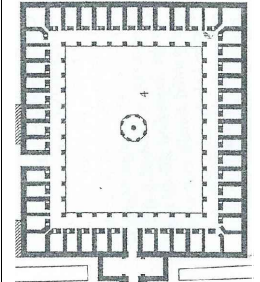
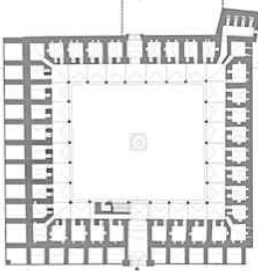
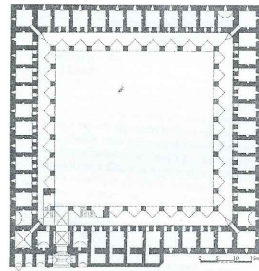
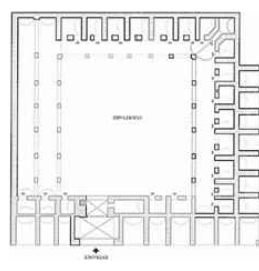
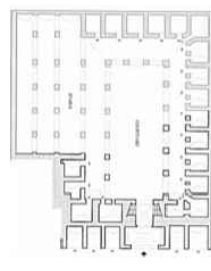
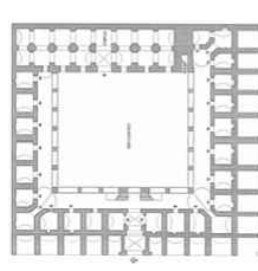
Table 4. Comparison of *Kurşunlu Khan* with other khan examples of the period.

| Name of the building  | <i>Bey</i> (Emir) Khan  | <i>Fidan</i> Khan   | <i>Geyve</i> Khan  | <i>Kutu</i> Khan  | <i>Taş</i> Khan   | <i>Çüplüce</i> Khan   | <i>Koza</i> Khan  | <i>Kurşunlu</i> Khan  | <i>Pirinç</i> Khan  | <i>Ali Efe</i> Khan   | <i>Bakır</i> Khan   | <i>Yeni</i> Khan  | <i>Taş</i> Khan   |
|-----------------------|---|---|--|---|---|---|---|---|---|---|---|---|---|
| Location              | Bursa   | Bursa   | Bursa  | Tire  | Bergama   | Tire  | Bursa   | Manisa  | İstanbul  | Tire  | Tire  | Tire  | Menemen   |
| Date of construction  | 1336  | 1400s   | 1400s  | 1429  | 1432  | 1442  | 1491  | 1498  | 1508  | 1525  | 1543  | 1543  | 1600s   |
| Architect in charge   | Unknown.  | Unknown.  | <i>Hacı İvaz</i> Pasha   | Unknown.  | Unknown.  | Unknown.  | <i>Abdullah Bin Pulad Şah</i>   | Unknown.  | <i>Yakup Şah</i> , the son of <i>Sultan Şah</i> , and <i>Ali</i> , the son of <i>Abdullah</i> | Unknown.  | Unknown.  | Unknown.  | Unknown.  |
| Emporor of the period | Orhan, I. (1326-1361)   | Mehmed, I. (1413-1421)  | Mehmed, I. (1413-1421)   | Murad, II. (1421-1444)  | Murad, II. (1421-1444)  | Murad, II. (1421-1444)  | Beyazıd, II. (1481-1512)  | Beyazıd, II. (1481-1512)  | Beyazıd, II. (1481-1512)  | Süleyman, I. (1520-1566)  | Süleyman, I. (1520-1566)  | Süleyman, I. (1520-1566)  | Ahmet, I.(1603-1617) or Osman, II. (1618-1622)                                      |
| Size                  | 47 x 49 m   | 63 x 69 m   | 35 x 36 m  | 43 x 33 m   | 26 x 29 m   | 26 x 32 m   | 63 x 71 m   | 51 x 48 m   | 74 x 75 m   | 48 x 38 m   | 38 x 43 m   | 43 x 47 m   | 30 x 30 m   |
| Plan scheme           |  |  |  |  |  |  |  |  |            |  |  |  |  |
| Sources               | (Ayverdi 1966, Yüksel 1983, Kuban 2007)   | (Ayverdi 1966, Yüksel 1983, Kuban 2007)   | (Ayverdi 1966, Yüksel 1983, Kuban 2007)  | (Armağan 2003, Çulcu 2005)  | (Ayverdi 1972 quoted from Baş 1989)   | (Armağan 2003, Çulcu 2005)  | (Ayverdi 1966, Yüksel 1983, Kuban 2007)   | (ARK İnşaat 2011)   | (Ayverdi 1966, Yüksel 1983, Kuban 2007)   | (Armağan 2003, Çulcu 2005, Tunçoku and Aktaş 2014)                                  | (Armağan 2003, Çulcu 2005)  | (Armağan 2003, Çulcu 2005)  | (Özkan 1994)  |

\*The drawings are not scaled.

## 2.7. Restitution States of *Kurşunlu Khan*

Over the centuries, the building has undergone a series of modifications, and transformations that were required due to either man-made or natural causes (Süllü 2010). Therefore, it is preferred to represent the khan according to determinate historic changes within the following temporal states: (i) the original state of the khan in 1498, (ii) the repaired state of 1643 following an earthquake in 1611, (iii) the repaired state of 1848 after a fire in 1843, (iv) the intervened state of 1908 due to re-functioning as a prison, (v) the intervened state of 1954 caused by a street widening, (vi) the restored state of 1970 following the restoration campaign of 1966-1970, and (vii) as-found state of 2011 (ARK İnşaat 2011). Nevertheless, it should be noted that, the states are not introduced solely in those certain historic moments, but also explained in the specific time interval for a better understanding.

### 2.7.1. Original State (1498)

The original state of *Kurşunlu Khan* dates back to 1498. In the bigger picture, understanding Ottoman Architecture of 15<sup>th</sup> and 16<sup>th</sup> centuries is quite challenging due to the lack of any existent original plans or models (Necipoğlu 1986). Nevertheless, specific to the case, the charter of the pious foundation allows us to reach one of the primary sources. In the original state, *Kurşunlu Khan* had 36 rooms on the ground floor and 38 rooms on the first floor, it had a big inner courtyard with a pool in the middle and a big stable at the rear. It is also recorded that it had 21 juxtaposing shops (Süllü 2010). Correspondingly, the khan carries typical functional characteristics of the *şehirçi hanları*, and was a profit-earning unit of the *Külliye of Hatuniye*. Today the mentioned stable and the pool do not exist anymore (ARK İnşaat 2011). Unfortunately, no remaining traces were found out remaining from the stable during the survey in 1966. But, it is thought that the stable was located in the Eastern direction, related to the Eastern gate. On the contrary, traces of a hexagonal pool were found in the courtyard (Oğuz 1974) which is supposed to mark the center of the courtyard (Gökçen 1946). The survey campaign prior to restoration works of 1966-1970 showed some clues regarding to the material culture of the building: chimneys made out of brickwork, the square brick tiles used as the original floor covering of the rooms, stone used as the original

floor covering of the semi-open parts, and lead is used with specific nails for the roof covering (Oğuz 1974).

The translations of the Charter by Süllü (2010) and Gökçen (1946) are found coherent with the findings of Oğuz (1974) about the building. Besides, those overlaps with the physical clues and characteristics of the building itself and is represented in the restitution drawings by ARK İnşaat (2011). Correspondingly, the information about the building, except the stable, are found 1<sup>st</sup> degree reliable information (Figure 27). The stable itself has descriptions about the location and its relation with the building, but there exists neither traces nor remaining about the geometric composition and size. This must be due to the durable material used for its construction. As a result, the stable offered in this study has 3<sup>rd</sup> degree reliability due to the uncertainties about exact location, form, size, and material characteristics.

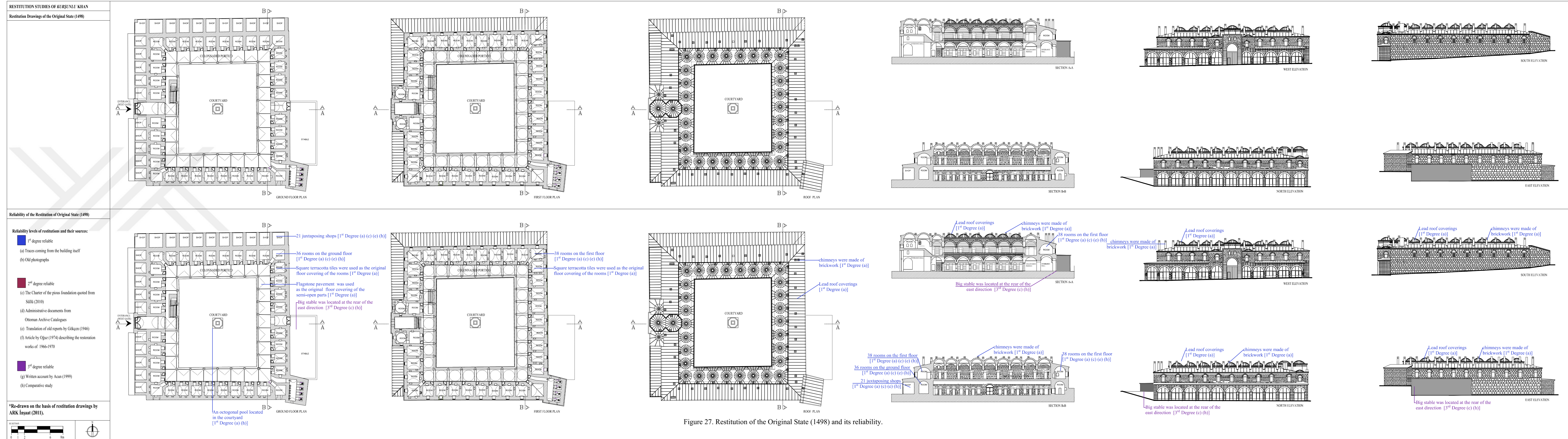

### 2.7.2. 2<sup>nd</sup> State (1643)

Emecen (1997) records that the rooms of *Kurşunlu* Khan were reserved to the accommodation of Jewish community referring to a document by the court of 1560. In that document, it was written that the first Jewish group, who arrived in Manisa following the expulsion by the Tribunal of the Holy Office, were residing in the rooms of the large pious foundation. At that time, the pious foundation by *Hüsnişah Khatun* was the largest one, and the rental income was providing an important and steady financial source.

*Kurşunlu* Khan was altered by the earthquake in 1611/1020. Regarding that an instruction on its repair is set from imperial center, Istanbul. Besides, a major repair campaign is held around thirty years later in 1643/1053. In the report of exploration prior to repairs, it is stated that 12 arches on ground and first floors in Southern direction, the roof cover of the stable, windows and doors of the rooms were damaged (Gökçen 1946).

In addition, in 1671, Evliya Çelebi recorded that the khan was a cereal market, and Persian and foreign merchants were staying there (Dağlı and Kahraman 2007) In another record, it is stated that one more repair campaign is held in 1677/1088 (Gökçen 1950). Other than these, no records of change found for the 17<sup>th</sup> and 18<sup>th</sup> centuries.

The restitution of the 2<sup>nd</sup> State is done representing the repairs of the 1643 as other changes are found indeterminate. Within the light of administrative documents translated by Gökçen (1946) the repaired parts have 2<sup>nd</sup> degree reliability as there is neither definite information nor clue on those repairs such as material, exact form, dimension or location. Besides, the roof cover of the stable has 3<sup>rd</sup> degree reliability due to the uncertainties about exact location, form, size, and material characteristics.(Figure 28).



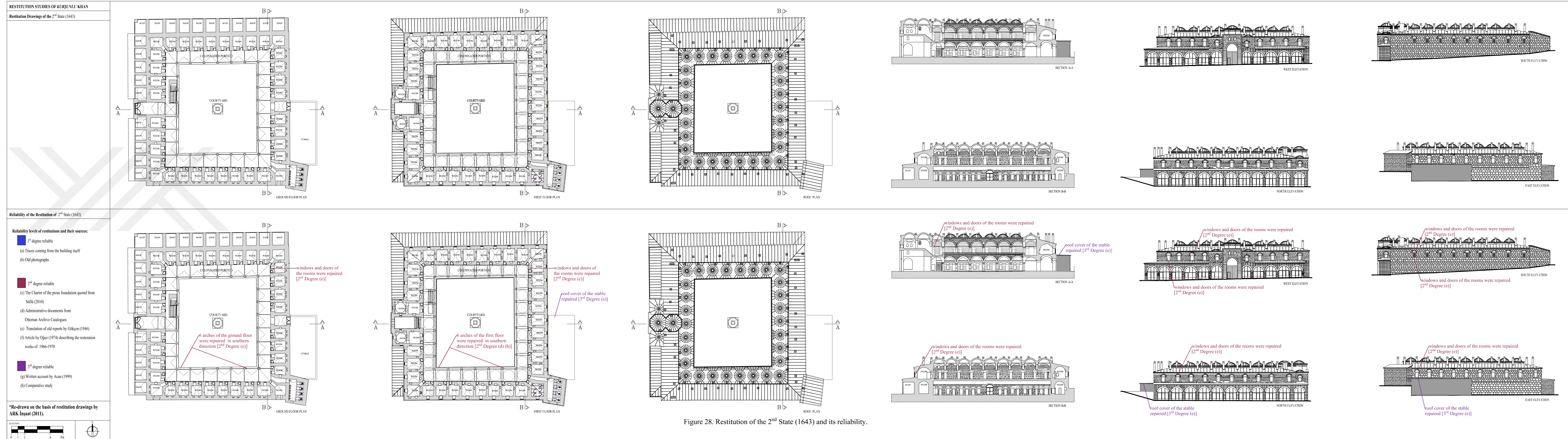

### 2.7.3. 3<sup>rd</sup> State (1848)

A report was submitted to the Governor of Aidin for the repair of the khan in 1843/1259 (The Ottoman Archive Catalogues 2015). Following, another report dating back to 1848/1264, and it was stated that some spaces of *Kurşunlu* Khan and its wooden skeleton of the roof were damaged by a previous fire. Besides until 1848, those were not repaired, which would cause an extensive repair and increasing cost day after day. Accordingly, a budget was provided from the imperial funds in 1848. Subsequently, a repair was held in the same year (The Ottoman Archive Catalogues 2015). As a consequence, the lead covering of the domes and vaults were removed, and it was replaced with terracotta roof tiles. Besides, and drums are added below the domes (Süllü 2010). Moreover, some other modifications were done on the ground floor. The shops located on the West direction were demolished and reconstructed with a longer depth. The portal was modified as well by adding a vaulted space in front, and a triangular pediment was added (ARK İnşaat 2011 quoted from the General Directorate of Pious Foundations) (Figure 29).

In 1862/1279, the building is contracted to the responsibility of *Sivashoğlu Tekfur Bezirgan* (The Ottoman Archive Catalogues 2015). Consequently, *Kurşunlu* Khan had undergone some repairs from time to time (Oğuz 1974) until the end of 19<sup>th</sup> Century. Nevertheless, the building kept its original spatial characteristics, excluding the shops located in West direction and and the portal. Besides, it continued its original function.

The documents from the Ottoman archive catalogues prove the interventions of the specific state; nevertheless, they lack information on architectural details such as form, size and material. Correspondingly, the repaired parts of the building in 1848 are found 2<sup>nd</sup> degree reliable. Other than that, the stable was not indicated in any source starting from this state onwards. Correspondingly it is thought to be demolished by the fire, and this unit is not included in this restitution state and in the followings preventing any speculative information.

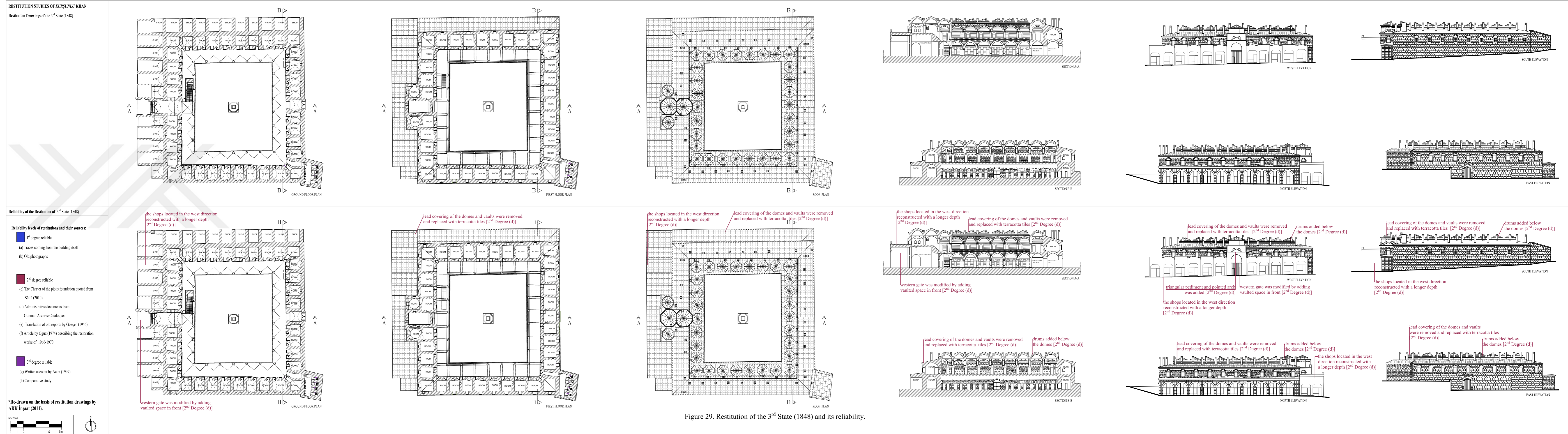

Figure 29. Restitution of the 3<sup>rd</sup> State (1848) and its reliability.

#### 2.7.4. 4<sup>th</sup> State (1908)

The refunctioning of the khan as a prison dates back to 1908/1325. It is stated that *Kurşunlu* Khan, which was the property of the municipality and located very close to the *çarşı*, was rented in order to cover spatial insufficiency of Manisa Prison for the actual number of the condemned people and due to the contagious diseases around them (The Ottoman Archive Catalogues 2015). As a result of the change in the function, some major interventions were done. The colonnaded portico was converted into closed-spaces, i.e. rooms. Those converted spaces were connected to the courtyard by rectangular windows and doors, one for each. A new semi-open space was created juxtaposing those rooms with a simple wooden construction (Figure 30) (ARK İnşaat 2011 quoted from the General Directorate of Pious Foundations). Although the changes are described as in the aforementioned documents, there are no clues coming from the building itself. Correspondingly, this information has 2<sup>nd</sup> degree reliability level.

#### 2.7.5. 5<sup>th</sup> State (1954)

The two thirds of the city center was demolished by the great fire in 1922, following the Turkish war of Independence (Köklü 1998). This situation motivated municipality of Manisa for the preparation of an application of a new urban plan, a French firm prepared a new urban plan in 1927 (Gürel 1984). Accordingly, Manisa had a new urban character following the foundation of Turkish Republic. The urban renovation and reconstruction process was started to be applied in 1925 including the rebuilding of the commercial city center, and this process continued for 13 years. Borsa Street, which is located at the Northern direction of *Kurşunlu* Khan is amongst the first new street application (Çetin 2012 quoted from Köklü 1993). As a result of that, the above mentioned Borsa Street, which is one of the major roads in Manisa, was widened in 1954 (Acun 1999). That caused the demolition of 11 shops of *Kurşunlu* Khan in the Northern direction. This was also proven by the investigations prior to restoration works of 1966-1970: traces of the original shops were found out by the rasp of the plaster of Northern walls (Oğuz 1974). After the demolition of shops, 9 of the rooms on the ground floor were converted into shops by adding openings facing to street (Acun 1999) excluding one, which was transformed into a gate (Oğuz 1974). In the

same period, the Northern façade completely changed, not only on the ground floor, but also on the first floor including the change of stone casings of the windows (Oğuz 1974). and their opening organization, and an application of plaster (ARK İnşaat 2011) (Figure 31). The information on the changes of this state is found 1<sup>st</sup> degree reliable as the aforementioned changes are determinate in both the traces coming from the building itself (Oğuz 1974) described, and also can be explored in old photographs.

#### **2.7.6. 6<sup>th</sup> State (1966-1970)**

In 1966, the General Directorate of Pious Foundations started a restoration campaign for *Kurşunlu* Khan in order to cover structural deficiencies and static weaknesses of the building. Accordingly, a restoration work was done from 1966 to 1970. Major decisions in that restoration work (Figure 32) were mainly in three principles: (i) consolidations and repairs with the original material where it was remaining original, (ii) replacement of the missing components with a more neutral form and material, and (iii) in parts where structural problems appeared, replacing the element in original geometry with the use of a stronger material (Oğuz 1974). To that day's knowledge, concrete was chosen as the material. It was believed that it would be identical in the future explorations and the material was more durable. Nevertheless, it should be underlined that, today it is an intervention decision to be avoided as it is also declared in international platforms (Feilden 1994).

The following interventions were done with the above listed principles:

First and foremost, the additional walls around the colonnaded portico on the ground floor are removed. This was due to both 55 centimeters fail in the structure, and inappropriate interventions in the past. Original columns and capitals were used in place with respect to the difference in their heights. The walls of the rooms were repaired by the use of original bonding system (Oğuz 1974). In addition, the casings of windows and doors located on the ground and first floors were replaced with concrete ones including their relieving arches (ARK İnşaat 2011).

Concrete beams were added in between columns, and between columns and walls for providing protection against any structural failure. Secondly, on the first floor, the columns were not found in a single fragment, but composed of multiple stones except only one column. Accordingly, those columns were replaced with concrete

columns with the same dimensions for a structural consolidation. Only, 38 centimeters concrete bases were added for leveling it with the arches connected to the first floor walls. The arches were reconstructed with stone and brickwork and the domes with brickwork as in the original state. The same application of the concrete beams was repeated here as well for providing protection against any structural failure. Moreover, a concrete guardrail with 90 centimeters height and molding made of concrete was added in between the columns of the colonnaded portico. In addition, the facades of the colonnaded portico facing to the courtyard were finished by saw-teeth eave composed of 5 consecutive layers like in the original state (Oğuz 1974).

More importantly, the shops located in the West direction were reconstructed into original size with respect to the traces coming from building. Additional building elements are removed from the main entrance, by this way the portal converted into its original shape.

Next, the Northern gate which was opened by the interventions of 1954 was closed, and the entrance hall converted into a storage space (Oğuz 1974).

The floor covering material was replaced with the original material, i.e., square terracotta tiles. The roof covering was thought to be replaced by lead as in the original state, however, galvanized sheet with a lead appearance was used due to the budget constraints. Next, the chimneys were reconstructed with a height till the upper level of the domes. A cylindrical terracotta pipe is placed above the chimneys, and finished with a conical element. Lastly, a hexagonal fountain was reconstructed, in smaller size, although an octagonal one was designed for the restoration project (Oğuz 1974).

The information on the changes of this state is found 1<sup>st</sup> degree reliable as they are explicit in the traces coming from the building itself, old photographs, and also clearly recorded in the article by Oğuz (1974).

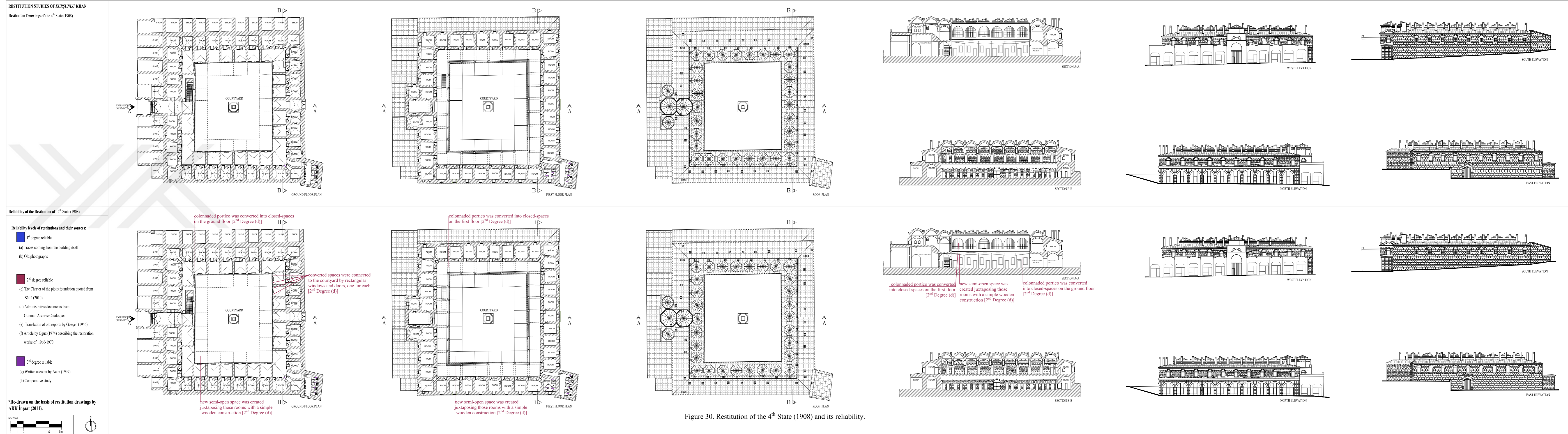
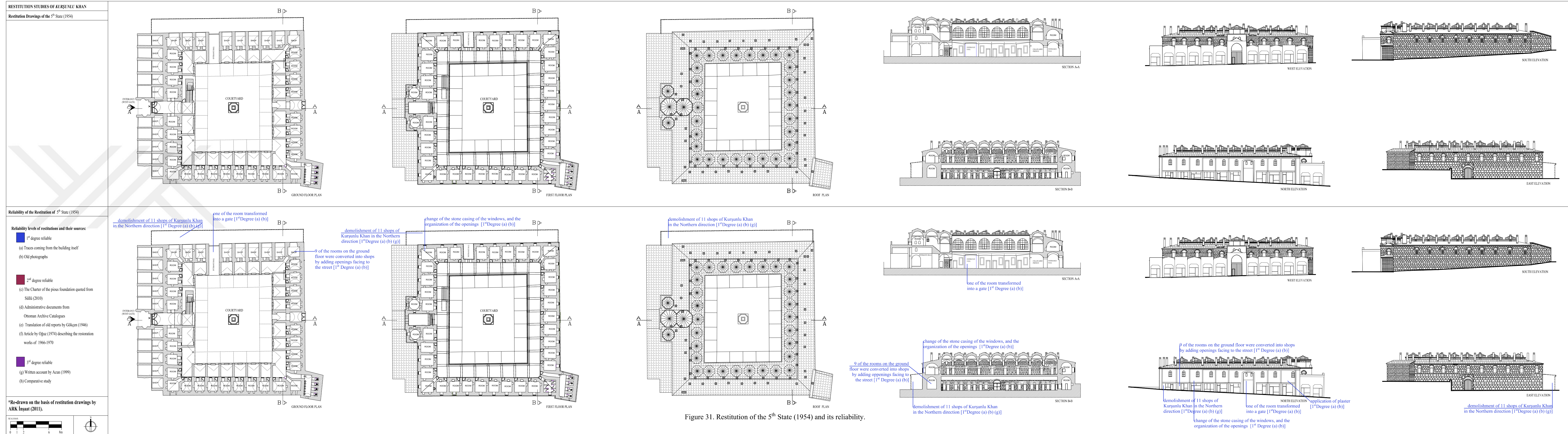

Figure 30. Restitution of the 4<sup>th</sup> State (1908) and its reliability.





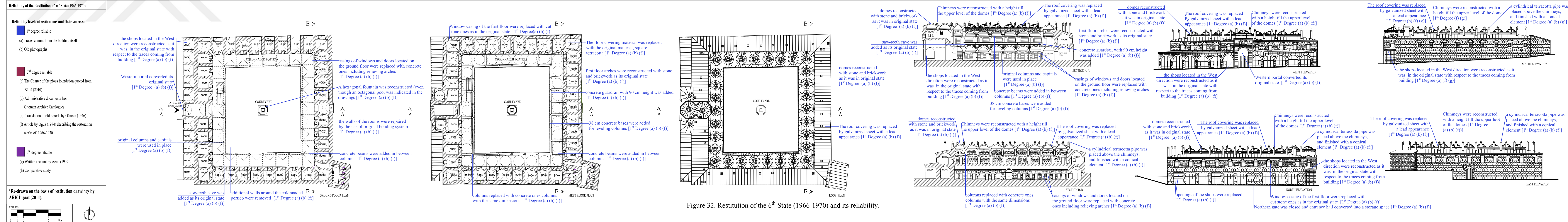
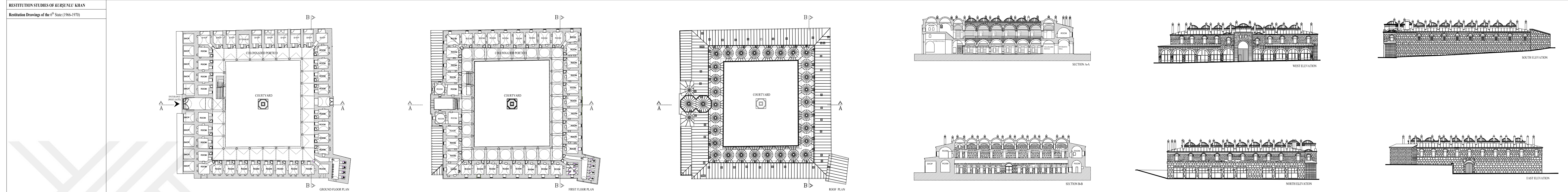
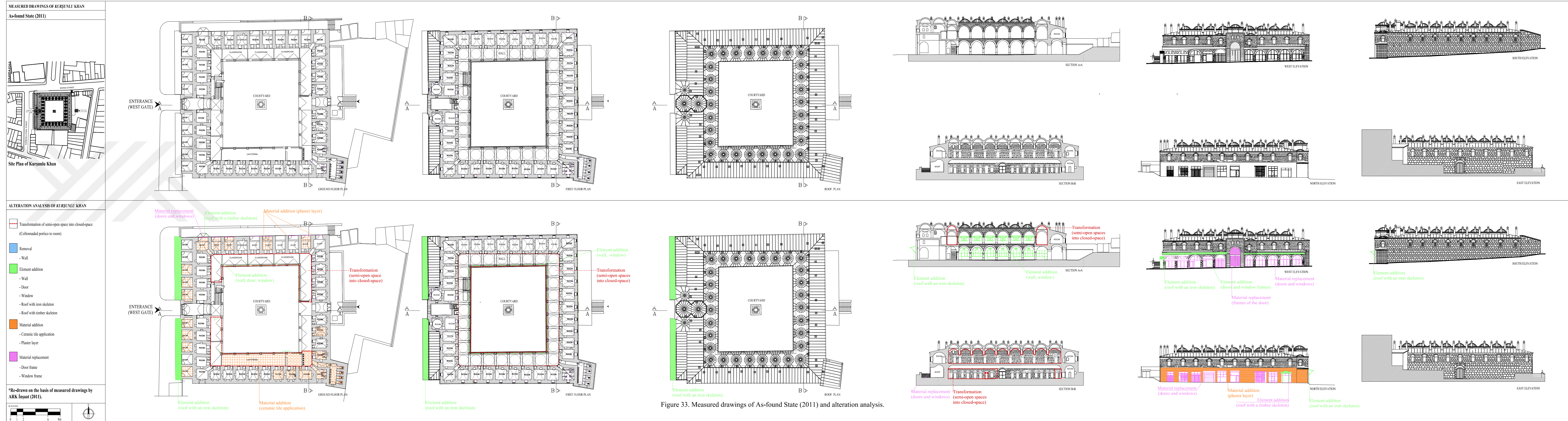

Figure 32. Restitution of the 6<sup>th</sup> State (1966-1970) and its reliability.

### 2.7.7. As-found State (2011)

When the changes following the 1966-1970 restoration works is investigated, it was found out that, the building was in use as a private dormitory by an association, namely, *İmam Hatip Orta ve Yüksek Tahsil Gençliğine Yardım Derneği*. The reports by by the Izmir Number 2 Regional Conservation Council of Cultural and Natural Wealth in 1991 shows that there were unconscious interventions to khan by the tenant. The amateur interventions following 1966-1970 restoration campaign caused the change of original geometric order by the unification of some rooms at the Southern part, removal of some chimneys and its related walls and addition of doors. In the following year of the investigation, those changes were removed, and the monument was partially transformed into its previous state. Other than that, some other minor interventions were done, such as ceramic tile application in WC, addition of movable water fountains to the Eastern gate, addition of a roof with iron skeleton to the Eastern facade, and dying and whitewash applications (Süllü 2010).

Nevertheless, those changes have uncertainties and limited to being solely descriptions as they are now not explicit on the site. Correspondingly, the measured drawings of the as-found state of *Kurşunlu Khan* of 2011 is used which are provided by ARK İnşaat. Accordingly, alteration analysis is based done on those drawings. It is found out that: colonnaded portico is transformed into classrooms and a cafeteria by adding walls, doors and windows on the ground floor. The colonnaded portico on the first floor transformed into a closed-space. A plaster layer is applied on the Northern façade for the ground floor. The frames of the openings of shops both on North and West directions are replaced with aluminum ones. Besides, a simple roof with iron skeleton is applied in front of the shops on the West. Ceramic tiles are applied for the flooring of some rooms. (Figure 33).



## CHAPTER 3

### STRUCTURING OF THE RESTITUTION DATABASE

All those involved with the understanding, care, and management of a heritage place must have access to existing information and will generate records, which must be preserved and made available to others. It is the task of heritage managers and decision makers to establish policies and programs for the correct recording and effective management of conservation-related information... (Letellier 2007)

As stated in the above lines of Letellier 2007, the correct recording and effective management of architectural heritage information has a priori importance. Correspondingly, this chapter focuses on “how to” establish and apply a coherent framework in order to fulfill that requirement, and in particular, it covers a methodological proposal for developing a restitution database, covering also a priori experiments shaping the decision process. Besides, it includes the definitions, characteristics and structure of the overall process of implementation.

#### 3.1. Terminology

There are a number of different terms that are used in this chapter with regard to the information management. The basic special words and phrases used in the particular field are briefly introduced in this section for a better understanding.

The first thing that should be cleared is the definition of the term *database*. A *database* is any collection of data (or information) that is specially organized for rapid search and easy retrieval in digital environment (Britannica Online 2016). Ogleby (2007) illustrates an adaptive definition of it for the architectural conservation as a collection of various types of data, including photographic images, sketches and measurements, condition assessments, and other pieces of information.

A *database management system* (DBMS) facilitates several processes like definition of data types, structures and constraints, structuring, and storing. It also

allows for manipulation of the database, querying specific data and any updates in database by changing values (Ramakrishnan et al., 2002). By these means, the databases store all data items in an integrated way rather than having redundant data in disconnected files. Hence, there exists the very common definition of databases as “self-describing collection of integrated data”. In a relative manner, there are five major components of a DBMS as: (i) a particular hardware corresponding to requirements, (ii) software for DBMS and any other complimentary applications, (iii) data as the most important component indicating both metadata and operational data, (iv) procedures defining rules and instructions, (v) distinct types of people participating in any level (Connolly and Begg, 2005).

A *data model* is a standardized way of organizing and structuring data. There are three level of abstract forms for any data model comprising *conceptual*, *logical* and *physical* levels. It is crucial to start the data modeling process with the definition of a conceptual data model in which the case’s specific properties and the users’ requirements are deciphered (Elmasri and Navathe 2011). A *conceptual data model* includes a map of concepts, their relationships and included semantics. In a common analogy, this process is quite similar to the paradigm of conceptual modelling in architectural design, in which architects seek for design concepts specific to project, and validate them according to the users’ criteria and needs (Yeung and Hall 2007). Similar to that metaphor, a conceptual data model is used in the initial planning phase of any database with graphic expressions and verbal descriptions for development, and it does not include any reference to the physical structure of the database. In particular, it is independent from any hardware or software. Consequently, the conceptual data model is the representation of the “real-world” features with the highest level of abstraction. This model represents those features to be included in the database and their characteristics (Connolly and Begg 2005). Secondly, the *logical data model* is the correspondence of all existent data in a standardized way and it is based on the concepts derived in conceptual data model. The logical data model (or schema) uses conventional relational database model notation, which is based on the mathematical concept of a relation and physically represented as tables (Yeung and Hall 2007). Lastly, the *physical data model* is the actual database design which is the physical representation of the database showing how all entities, relations and attributes are stored. Besides, it includes the representation of how different end users perceive the interested data.

The brief introduction above about the three keys, i.e., database, database management system and data model, is given to provide a link to the basics of the field. Nevertheless, the peculiarity of each application requires use of other terms which will be described in the related applications during the methodological flow.

Eventually, this chapter is devoted to the implementation of the proposed restitution database, and also related a priori works. Therefore, preliminary experiments with both BIM and GIS as commonly used models are described in Section 3.2 exposing pros and cons of commonly used models, and beyond that to propose a methodological flow for architectural heritage information management. It is followed by a critical look at the approaches including their comparison in terms of the capabilities in Section 3.3. Afterwards, a detailed description of the implemented database as a hybrid approach is illustrated in Section 3.4. Besides, it includes, the inspection of the data model in the context of conceptual, logical and physical levels. The aspects of the proposed database in that framework, including geometric and spatial data model, data integration, storage, management, and access and visualization are evaluated in the framework of the database management systems.

### **3.2. Preliminary Experiments**

Considering the peculiarities of historic buildings, databases help separating segments of information and putting these segments together in a structured way for allowing new information to be derived or linked to 3D data (Agugiaro et al. 2011 and Von Shwerin et al. 2013). This means the use of semantic enrichment of 3D models, which is also the solution for restitution phases of a historic building. The criteria for its production process needs:

- (i) Definition of specified mutual and hierarchical relationships,
- (ii) attribute management,
- (iii) 3D editing functionalities,
- (iv) spatial and multi-criteria query-able characteristics,
- (v) representation of datasets in 3D,
- (vi) representation of restitutions.

Consequently, it is a complex spatial assessment process (Saygı and Remondino 2013). Regarding the defined criteria above, it is necessary to go beyond the geometric

data composed of either 3D geometries or 2D primitives as lines and points, and engagement of the detailed geometric and related spatial data with non-geometric data types. In this context, preliminary experiments respectively with Building Information Modeling (BIM) and Geographical Information Systems (GIS) are held.

### 3.2.1. Experimentation with BIM

As of today, there exists a number of BIM software. At the core of any BIM approach there are model-centric workflows. These workflows determine the methods and techniques for creating asset models as various outputs such as 3D model, section, plans, etc. (Autodesk n.d.). As of today, researchers find that Autodesk Revit as the most comprehensive one among others, that software is selected in order to carry out experimentations. The concise workflow in the BIM experiment for the case study is illustrated in Figure 34.

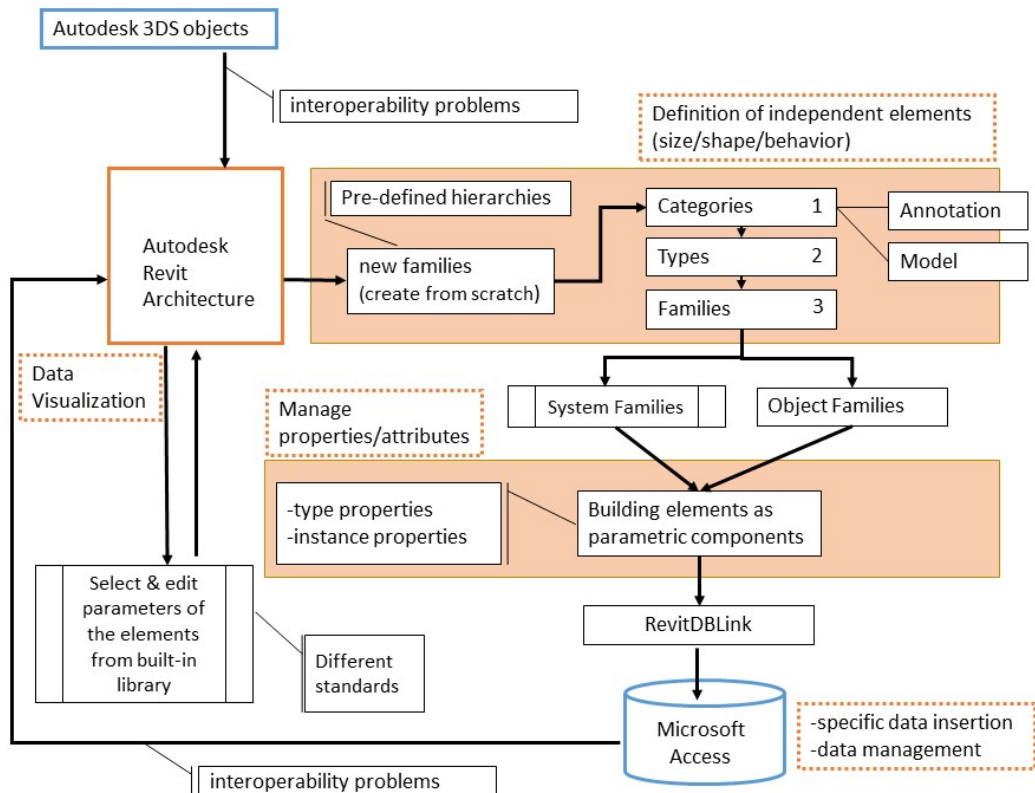

Figure 34. Workflow in BIM environment.

In Revit environment, typically, a building can be created by 3D building components, e.g., walls, floors, roofs, doors, etc., which are offered as built-in parametric 3D building components. This allows users to modify a given component by changing predefined parameters such as height or width. Each component is belonging to a “family”, i.e., components from the same genesis, with a file extension of *.rfa*, which can be modified and imported into a Revit database. Nevertheless, the customization is very limited for those built-in objects (Saygi et al. 2013). Regarding the complexity of 3D geometric and spatial properties of a heritage building, an alternative way is selected to build new components, and their respective families starting from the very beginning. This initial phase has been possible with the use of pre-made solid objects one by one. Following that process and corresponding historic buildings’ components (due to building deformations or alterations), there is a need for modifying an object’s individual polygons, but as it lacks the ability in some geometries this has barely been possible.

After creating a new family and its belonging building components, component and family parameters can be created, and the combination of parameters can be saved as a type. Thereby, the process of component creation as new 3D parametric objects - the objects which have values that can be change by altering the size or shape of the object for the case study has not been a simple task. In order to overcome the difficulties, importing objects from Autodesk 3DS Max is also considered. But, it has not been a practical solution as the produced 3D geometries could not be directly linked directly due to the interoperability facts. On the other hand, the structure scheme of Revit offers only fixed hierarchies which do not fit into specific needs of a historic building (Saygi and Remondino 2013).

The following phase has been the management of properties by assigning attributes. Inside Revit, editing type and instance properties has been very limited. So, migration into the Microsoft Access is considered as there is a built-in support by RevitDBLink. The exported data include assigned parameters such as length, volume, material, etc. to components in worksheets. In Microsoft Access, it has been possible to insert specific data by adding new columns to a table for integration. However, any manipulation in the already exported data has not been possible. Other than the aforementioned points, a critical concern has been due to the fact that chain between Revit and Microsoft Access is incompatible for 64-bit Windows environments.



### 3.2.2. Experimentation with GIS

There is a variety of GIS software for managing multi-layered spatial data; nevertheless, those are generally bounded in 2D with some exceptions in 2.5D – extruded building footprints – as external surface models. Esri ArcGIS is the one that supports 3D functions with its modules of ArcScene and ArcGlobe. As a heritage building necessitates analysis in 3D, Esri ArcGIS was selected to conduct the experiment. In a typical workflow of ArcScene, it is possible to create new 3D features with the use of polygons or multipatches produced in ArcMap. However, the production of the new geometries representing building features has been very limited and time-consuming. Consequently, they are modeled in an external but more conventional environment, i.e., Autodesk 3DS Max; afterwards, imported into the ArcScene. Throughout the modeling process, each building component is modeled individually in order to create segmented 3D model. Nevertheless, it should be noted that conversion process causes some loss of information. After all, the 3D model could be used for enhanced attribute management by means of GIS' data management capabilities. The brief workflow in the GIS experiment for the case study is illustrated in Figure 35.

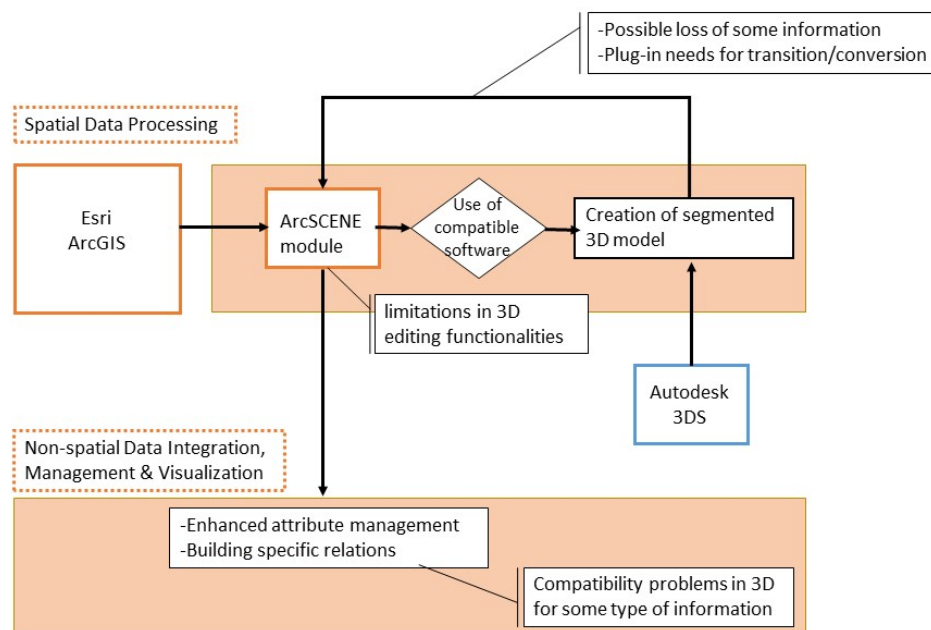

Figure 35. Workflow in GIS environment.

### 3.3. A Critical Look at the Approaches

Within the light of the experiments shown in Section 3.1, and the critical evaluation of the current works in literature in Section 1.2, it is found out that both approaches have some restrictions due to their specifications considering the needs historic buildings and representation of their restitution states (Table 5).

Table 5. Comparison of the capabilities of BIM and GIS for the semantically enriched 3D model creation (Source: Saygi and Remondino 2013).

| <b>Criteria for Information Management Process</b>            | <b>BIM</b> | <b>GIS</b> |
|---|------------|------------|
| Definition of specified mutual and hierarchical relationships | ✗          | ✓          |
| Enhanced attribute management                                 | ✗          | ✓          |
| 3D editing functionalities                                    | ✓          | ✗          |
| Spatial and multi-criteria query-able characteristics         | ✗          | ✓          |
| Representation in 3D  | ✓          | ✗          |
| Representation of restitutions                                | ✓          | ✗          |

On one hand, in a BIM environment "intelligent" building elements and 3D digital models can be created. They consist of full architectural properties (dimensions, material, texture, etc.), but there is lack of integration of new attributes covering restitution states of a historic building which are different than the "standard" architectural properties. More importantly, the building elements are bounded to the specific library of BIM software which are based on new building technologies according to their specifications. Creation of new elements and families is a long manual process, especially if we think that "historic" buildings are often composed of "non-standard" elements, or some architectural features are not used anymore, as BIMs are conceived for modern buildings. Today, there is a great attempt to increase BIM capabilities for more comprehensive, sophisticated and query-able characteristics (Garagnani & Manferdini, 2013), but there are no applications covering the characteristics of historic states yet. Besides, post-data processing for attribute enhancement and integration of different datasets is unresolved. The Industry

Foundation Classes (IFC), a standard data format developed by international Alliance for Interoperability, aims to cover both geometries and semantics (Kolbe and Plümer, 2004). Recently new attempts for post-data processing and data management have been presented, both as open and commercial software solutions. Examples are Building Information Modelserver (<http://bimserver.org/>) based on IFC format, the Open BIM movement initiated by Graphisoft, Tekla and buildingSMART (<http://www.graphisoft.com/openbim/>) for enrichment of attribute data related to building elements, zones or complete buildings (Saygı and Remondino 2013). Nevertheless, enhanced attribute management for restitution states is not yet an integral part of them. In other words, the integration of external attribute data is at the moment not fully covered. In addition, an historic building necessitates an integrated representation of different restitution states. This requires a layered modeling approach in which we can select a temporal state, and represent it in a multi-layered 3D environment.

On the other hand, it is possible to create and access semantically-rich objects in GIS environment (Kolbe and Plümer, 2004). In this context, attributes can be easily joined to geometries and a relational database can be built in GIS. Nevertheless, “standard” GIS products are still limited with regards to 3D editing functionalities as they generally only allow construction of simple 3D elements as geometric primitives. So, creating and visualizing complex 3D restitution models using a GIS software can be still problematic. In order to solve this, any compatible 3D modeling software can be used for modeling, coupled with some plug-ins for importing/exporting, but this inevitably makes the process longer. As an exemplification, we can create detailed 3D models in Autodesk 3DS Max and import them into GIS environment with the use of plug-ins. However, in the conversion process, as the geometrical schemes and related descriptions are different and (sometimes) not compatible at all, some information might be lost during the process, so that particular attention must be paid during this phase. Although, GIS products are still limited with regards to 3D editing functionalities if once 3D geometrical modeling is done with compatible software, GIS show the possibility to identify key aspects for representation of different information, enhancement with any type of attributes, and query or visualize any thematic concepts in 2D/3D/4D forms.

In summary, the outcomes of the preliminary experiments have shown that neither using BIM or GIS solely corresponds the particular needs of structuring a

restitution database. In the former it has been possible to manage architectural data in 3D environment, but attribute enhancement and integration of non-geometric data were barely possible. In the latter, 3D modeling was quite compelling and inefficient, whereas it allowed advanced attribute enhancement. Correspondingly, both of them do not directly support an efficient restitution database for a historic building. Within the light of these outcomes, a new methodology is offered for structuring a restitution database which can be applicable to any other historic building with some calibration. The system offers linking of heritage data gathered throughout the synthesis of restitution is integrated to the 3D geometric model, and representation is provided through graphic and tabular interfaces.

### **3.4. Definition and Characteristics of the Proposed Approach**

In this section, the proposed methodology (Figure 36) is implemented for the case of *Kurşunlu* Khan, with respect to the requirements of understanding the “wholeness” of the historic changes of the building. Accordingly, the analyzed information behind the 3D geometries is formulized and systemized for structuring non-geometric data types, i.e., (i) textual data (archival information, written documents), and (ii) raster data (photographs, old maps, scanned documents).

The proposed restitution database should allow archiving of semantically enhanced 3D model for each restitution state of the building in a flexible way, and be capable of assignment of different data for its diverse parts and components. Therefore, an efficient restitution database necessitates structuring according to these requirements. The process, and related tools and software is illustrated in Figure 36.

Each step is introduced and extensively demonstrated consecutively in the following sections.

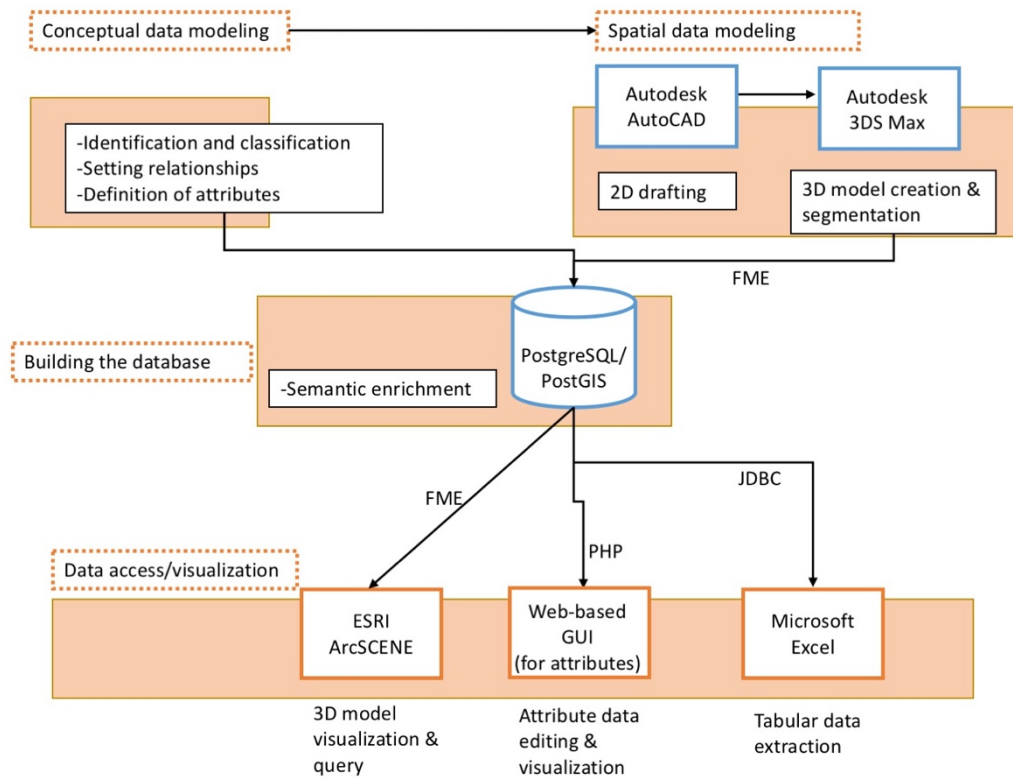

Figure 36. Overall workflow and architecture.

### 3.4.1. Conceptual Data Model

Conceptual data model is set on the abstraction mechanism, and it is evaluated in three piers of (i) identification and classification, (ii) setting relationships, and (iii) definition of attributes.

#### 3.4.1.1. Identification and Classification

The central task in the conceptual model are objects (also called as entities or instances). As a consequence, “identification” of these objects is crucial. In the real-world manner, an object is described as “a thing with conceptual or physical existence” (Elmasri and Navathe 2011). An object is a uniquely identifiable entity that has special characteristics for describing the state of a ‘real-world’ object and the actions (Connolly and Begg 2005). Accordingly, a unique identity is defined by each object. Besides, the

object can be both an atomic one or a collection object (Elmasri and Navathe 2011), i.e., objects can contain other objects.

All starts with the abstraction, so, the identification of the “seen” and related classification of the objects is closely related to the “reading” metaphor for the architecture of any building. Any description of an architectural property has double sided aspects: solid and hollow components (von Meiss 2013) coming together to produce the “wholeness” of human perception. Therefore, there exists: first, the building elements as the solid features, and second, the architectural spaces as the hollow ones. The former is a mathematical construction of physical components which have roles (functional, constructive, etc.) and morphologic types. The latter is born from the specific relationships among the former, and has explicit limits created by them. In other words, the spaces are identifiable as different hollow volumes that one can interpret following a cognitive process as they are not physical solid geometries (Figure 37).

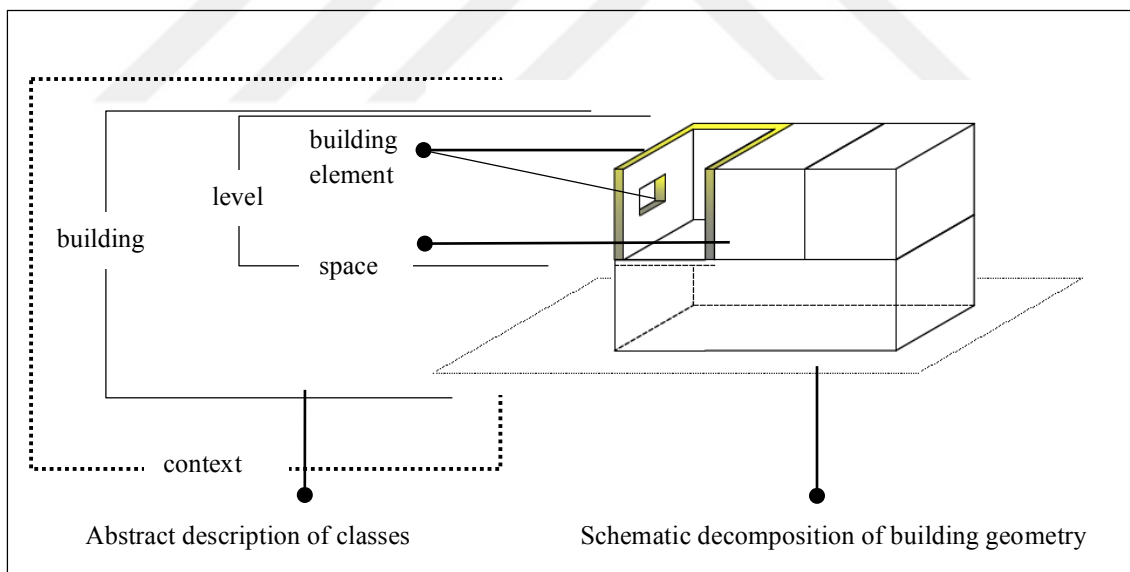

Figure 37. Reading a building and identification of features.

As a result, objects that have the same characteristics and respond to the same messages are grouped together to form “classes”. In other words, a class encapsulates all objects which share common properties. The process of classification involves systematically assigning similar objects to the classes. So, the classes are reasoned rather than individual objects (Elmasri and Navathe 2011). By this way, the characteristics and associated properties can be defined once for the class rather than separately for each object (Connolly and Begg 2005). As a consequence, the features of the building are characterized by the common properties in the abstraction. As classes are identified, meaningful names to them are assigned by the user(s). In this respect, the collection of objects with shared structure and behavior (Yeung and Hall 2007), i.e., classes in this research, are shown in Table 6. Besides the names, the descriptions of classes are defined in there.

Table 6. The classes and their definitions in the proposed data model.

| Class Name       | Description   |
|------------------|---|
| Site             | is the indispensable piece of the ground and the surroundings which shapes the building context.          |
| Building         | is the product of an architectural design and construction work.  |
| Level            | is the horizontal partition of a building.  |
| Space            | is a volume defined by physical boundaries and devoted to a particular purpose.                           |
| BuildingElement  | is any solid component of an architectural property.  |
| Wall             | is any upright and planar building element shaping the enclosure, and bearing load in vertical direction. |
| Column           | is an upright slender building element bearing load in vertical direction.                                |
| Arch             | is a curvilinear building element spanning an opening.  |
| SemiCircularArch | is an arch with a single central point.   |
| PointedArch      | is an arch with two centers.  |
| OtherArch        | is any other variation/type of arch.  |

**(cont. on next page)**

Table 6 (cont.).

| Class Name              | Description   |
|-------------------------|---|
| Vault                   | is an arched building element surmounting a space.                            |
| BarrelVault             | is a vault with semi-circular cross section.                                  |
| CrossVault              | is a compound vault by the perpendicular intersection of two vaults.          |
| OtherVault              | is any other variation/type of vault.   |
| Dome                    | is an hemispherical building element shaping a roof or ceiling.               |
| Spandrel                | is an upright building element between the adjoining two arches.              |
| Roof                    | is a building element forming external upper cover of a building.             |
| Window                  | is a light framework for air and light covering an opening of a space.        |
| Door                    | is a light framework for human access covering an opening of a space.         |
| Beam                    | is a linear horizontal building element loaded transversely.                  |
| Niche                   | is a defined open-space in a wall.  |
| Fireplace               | is a defined open-space in a wall for fire.                                   |
| Chimney                 | is an upright building element for the smoke of fire.                         |
| Slab                    | is any horizontal and planar building element shaping the enclosure.          |
| SlabInstallation        | is any type of installation on the slab.                                      |
| Fountain                | is a building element in various geometric shapes pouring water into a basin. |
| Pool                    | is a defined hollow space on the ground, containing water.                    |
| Staircase               | Is any other variation of installation on the slab.                           |
| OtherSlabInstallation   | Is any other variation of installation on the slab.                           |
| AbstractBuildingElement | is any other variation/type of building elements.                             |



### 3.4.1.2. Setting Relationships

Another step is to identify major classes and the classes representing the qualities of them. This process begins by defining superclasses and subclasses or inheritance, by this way the objects and classes are connected to one another through links. As an exemplification, the concept of “building element” is a class whose members are all building elements, e.g., wall, spandrel, vault, dome, and so forth. all. In this task, building element is the superclass of wall, or wall is a subclass of building elements. Behind that simple structure lays of the hierarchical model which can be represented as a tree graph, with records appearing as nodes (Connolly and Begg 2005). Basically, it works like a tree-like structure (Halpin and Morgan 2008). As seen in Figure 38, there is the class of “building elements”, and the “spaces” which are identified by them. They make the “levels” up and then the whole, “building”.

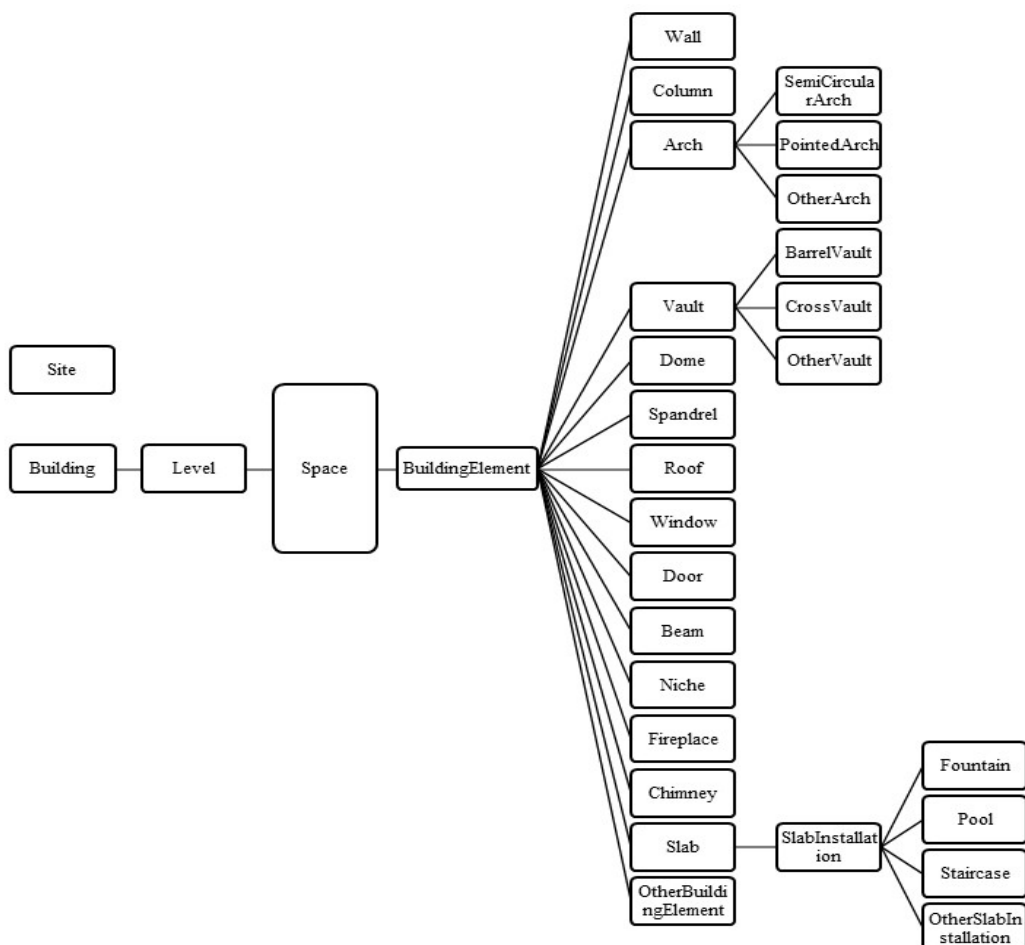

Figure 38. Tree graph representing the classes used for *Kurşunlu Khan*.

Next, for setting particular hierarchies and assigning different associations, the conceptual synthesis of generalization and aggregation are needed. In generalization, the differences among entity types are not considered, but their common features are identified and generalized into a single superclass (Elmasri and Navathe 2011). It is the basic type of inheritance, this association described as is-a-subclass-of relationship or is-a relationship. For example, the class “Vault” is a generalization that includes the classes of “BarrelVault”, “CrossVault” and “OtherVault”, i.e., a cross vault is a vault.

Aggregation is an abstraction concept for representing a relationship between a whole object and its component parts. It is an association that represents a part-of relationship. In this respect, which a new class from one or more sets of other classes are defined in order to represent component parts (Yeung and Hall 2007). For example, the class of “space” can be abstracted by aggregating the classes of “wall”, “window”, “door”, “slab”, “dome”, and so on. In the aggregation, if a class is removed, the objects can continue in existence whereas in its variation of association, objects are removed as well. In other words, there is a lifecycle dependency between objects and their superclass.

### **3.4.1.3. Graphical Notation of the Conceptual Model**

Figure 39 is the conceptual data model prepared for the case study. A standard of graphical notation and vocabulary is used thanks to the Unified Modeling Language (UML) (Booch et al. 1999) for the structural scheme and dynamic behavior. This is to say that UML is not a method, but a language for expressing specific operations (Fowler 2004).

The diagrammatic representation of each class is displayed in a rectangular form and labeled with its unique name. In a standard use, the label must be a single noun, e.g., Wall, but in case of the need for a phrase, i.e., a camel case compound word is used, each initial letter of the words making up the phrase in order to represent the class name should be in uppercase, e.g., BarrelVault. The rectangular box is to represent classes, and it includes three sections: the top section gives the class name, the middle section includes the characteristics (or attributes) for individual objects of the class, and the last section includes selected operations applied to these objects, i.e. the methods (Elmasri and Navathe 2011).

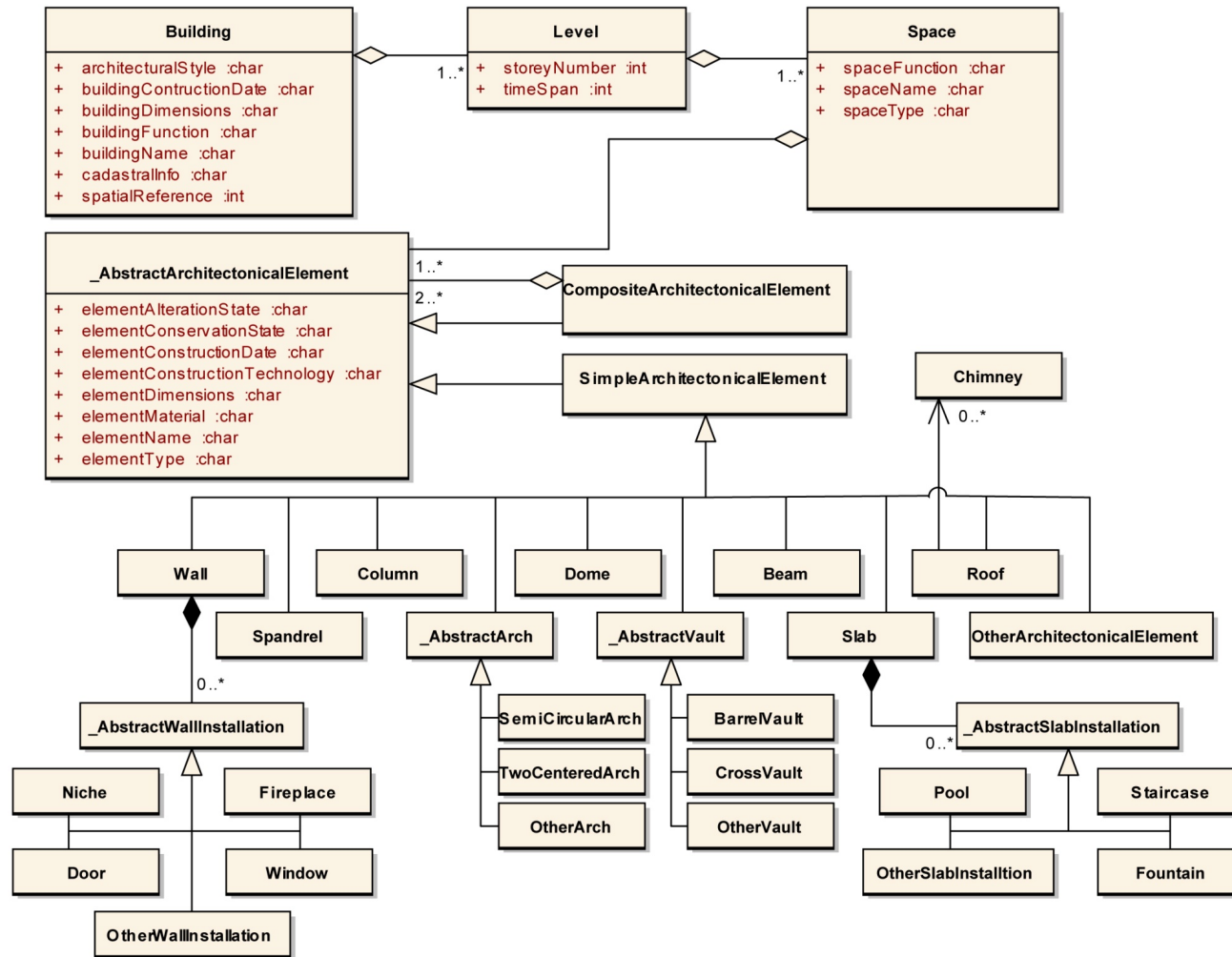

Figure 39. UML diagram for the case study (Source: Booch et al. 1999).

In the diagram, relationships between classes are simply represented by lines with symbols at the end of the line indicating the type of relationship for each participating entity. It should be noted that the relationship is only labeled in one direction as the relationship works only in that direction. Once the relationship type is chosen, the respective symbol is placed beside the name of the class indicating the correct direction for any reader to interpret the relationship. In particular, the basic diagrammatic notation is as follows: (a) hollow triangle symbol is directed to the superclass and connected by a line to the subclasses, (b) a hollow diamond shape which is used in order to represent aggregation, (c) a solid diamond shape is used in order to represent composition, with a small but crucial difference: there is a lifecycle dependency between instances and their superclass, i.e., when a class is removed, the instances are removed as well.

#### **3.4.1.4. Definition of Attributes**

To sum up previous process, classes create a common ground for shaping the whole. Therefore, a better management of information necessitates structuring and relating those classes. Consequently, (i) “classes” which help us to identify the building geometry, (ii) “building elements” gathered deciphering structure, (iii) “geometries of building elements” for specifying each, (iv) “spaces” visually created by those building elements, and (v) “building element – space relations” should be clarified, defined and structured. Nevertheless, these are not enough to cover the holistic aspects of a historic building without inclusion of (vi) “restitution states” for deciphering crucial time intervals in the building’s history. Besides, (vii) “external data” covers digitized information sources in different formats.

Once, the above mentioned classes are decided, the next requirement is to answer the following: “What information is to be hold on these classes?” The answer to this question is hidden in specifications of the analysis of data regarding *Kurşunlu Khan* (Please see Chapter 2). In an abstract manner, by far the easiest thing to do is using identifications in order to examine specifications. From this specification, nouns or phrases which are of interest for the concepts are defined for the 3D models in variations of different restitution states.

First of all, each restitution state is evaluated as an independent information container. In each 3D restitution state model, there will be specific state name, the function used during that phase, the cadastral information gathered from legal administration, the volumetric composition of each, the specific time intervals, the numeric information on the model geometry, and old photographs and documents.

Next, the concepts to be represented in the 3D models are defined. Firstly, there are the “classes” in which names, inheritances and descriptions are included. Secondly, in “building elements”, the name of the element, the restitution state it belongs to, the reliability of the each are included. Thirdly, in “geometries of building elements” there are the independent layers and 3D models of segments composing the building. Fourthly, there are “spaces” in which their name, belonging level, relative function, spatial type, geographic orientation, and existence of change are included. A traditional space labeling, clock-wise in direction, outside to inside, has been useful for its fast systemization. Fifthly, “building element – space relations” represent the inheritances, i.e., the specific building elements in relation to specific spaces are indicated. The same procedure is repeated for the “building element-space” relations”. In summary, the nature and properties are determined for each, and attributes identified according the specifications.

### **3.4.2. Spatial Data Model**

At present, architects use 3D modeling as a standard practice for efficient visual representation of the buildings. Correspondingly, conservation-architects represent digitally historical buildings in 3D in diverse form of applications such as digital data acquisition, digital reconstructions, virtual-museum applications, etc. Besides, the 3D model is the most desirable way of virtual representation since it offers users an unrestricted and holistic visualization (El-Hakim et al. 2007).

Unlike the approaches based on-site data collection with the results of digitally born 3D material, this study makes use of readily available information. The available graphical documentation is in forms of architectural plans, sections and elevations which is a standard way for representing architectural heritage information, however mostly in 2D. And, the representations cover two types of data-sets as measured drawings and restitution drawings. All are available in forms of 2D CAD drawings

(ARK İnşaat 2011) which are composed of geometric primitives and textual annotation. Nevertheless, moving towards 3D models from 2D drawings is not only the creation of volumetric objects but it is actually a more complex process. As of today, generation of 3D models from 2D drawings can be automated (Or et al. 2005, Moloo et al. 2011, Turner and Zukhor 2014), semi-automated (Lewis and Sequin 1998) or manual (El-Hakim et al. 2007). Whatever method is applied they require all a significant manual pre- and post-process effort (Yin et al. 2009, Gimenez et al. 2015). In particular, for historic buildings which are composed of complex geometries which lose similarities of their shapes in object level, a manual method is mostly required.

As the 2D CAD drawings cover the building's layout, it lacks details and spatial descriptions for holistic representations. One promising approach is to derive the 3D building models generated from 2D CAD drawings, and then, to complete and update the model with other available data-sets, e.g., old photographs, historical texts (Gimenez et al. 2015). The process of 3D model generation from 2D drawings is effectively possible for qualified representation of any spatio-temporal state. Eventually, a manual methodology for geometric modeling derived by the use of computer aided architectural design (CAAD) methods is adopted for *Kurşunlu Khan*. It is aimed to reach 5 centimeters of accuracy for representing level of detail (LoD) in which there will not be finite model details, but will offer quite efficient understanding of the building.

A deductive approach is considered for the logical segmentation of the *Kurşunlu Khan* with correspondence to the classes and relations defined in conceptual data model. On the contrary, an inductive approach is applied for the building as assigning different data-sets including textual, numeric, vector, raster data types to objects and classes, and correspondent "wholeness" requires the creation of a segmented 3D model (Manferdini and Remondino, 2010). Consequently, the creation of the segmented 3D model has been a reverse engineering process, the model is drawn from smallest segments, i.e., sub-classes of building elements upwards which would allow assigning the above mentioned thematic datasets to the objects and classes of the 3D model.

Autodesk 3DS Max, which is a software allowing flexible creation of any geometry, is used as the 3D modeling tool. In the overall process, the aim is to produce 3D triangular meshes describing objects. Accordingly, closed polygons and definitive solid features are used. Basically, 3D modeling is started with the extrusion process of vertical components, i.e., walls, using 2D floor plan created in AutoCAD. Nevertheless, it is not a straight-forward process and a considerable effort must be paid in the

following issues: (i) the segmentation decision for overlapping or joining edges, (ii) the differences in height information on a single object, (iii) openings that are in non-rectilinear forms to be subtracted. Another step is the modeling of geometries which cannot directly be created by the extrusion of planimetric information. Building elements such as arches, vaults, domes, spandrels, columns are modeled individually with correspondence to their belonged sub-classes. Nevertheless, modifications are done for each individual object in order to cover all the diversities, i.e., changes in dimensions (height, width, diameter, etc.) and inclusion of specific alterations. Thirdly, horizontal components in forms of slabs are considered. The decision of the detection of the boundaries of each is done with correspondence to the building element-space relations. Lastly, other specific building elements and installations such as doors, windows, chimneys, moldings, staircase are modeled (Figure 40).

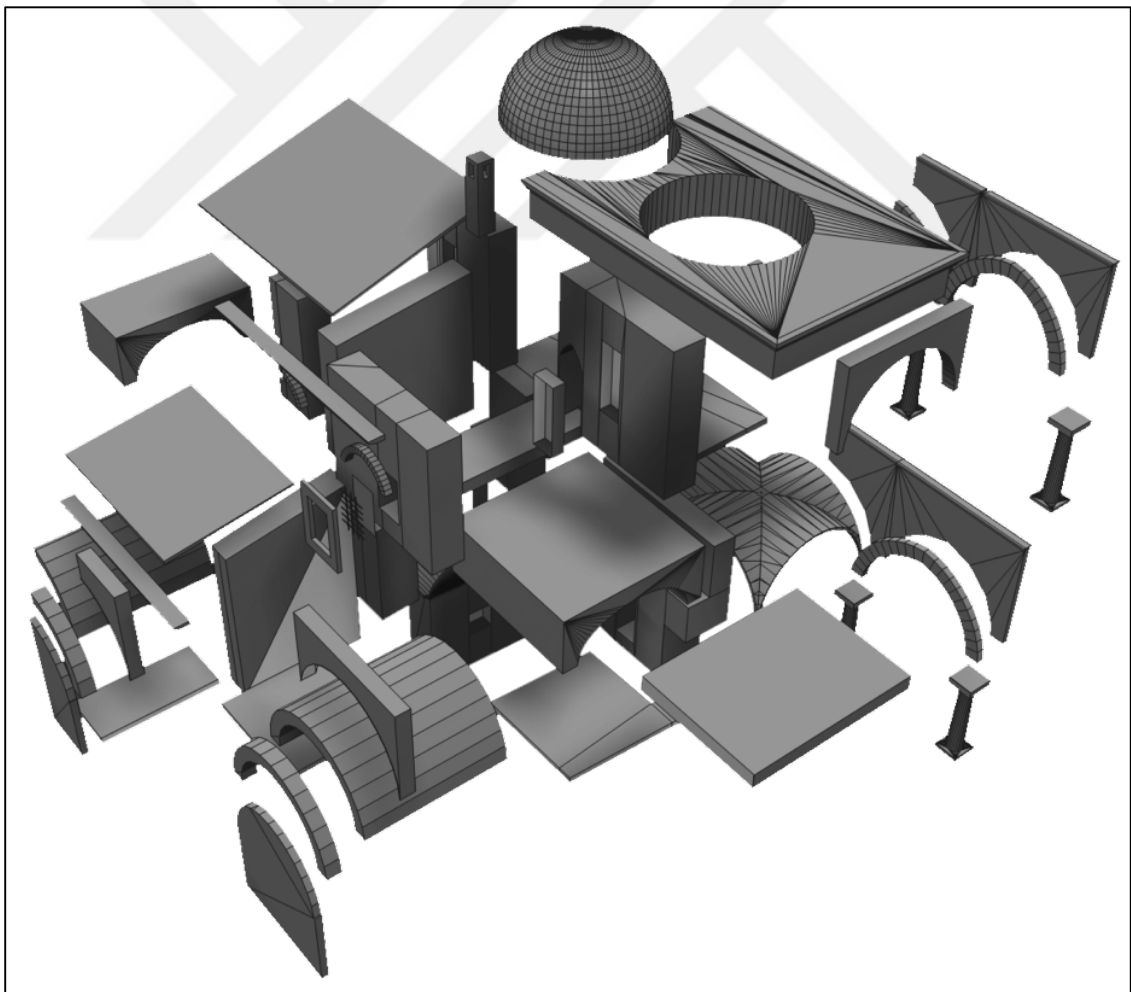

Figure 40. Exploded view of the (partial) segmented 3D model.

In 3D modeling, it is aimed to characterize each building element with a specific name and function, in order to place it conceptually into the tree diagram. In this case study, a naming convention is applied as a practical solution for the assignment of each corresponding class. This is to say it is done by means of a standardized name coding, due to the scarce capabilities in 3DS Max to write attributes to the geometries. Hence, it should be noted that in use-case of another software, one may have to adopt other strategies in order to have each geometry classified within tree diagram.

Correspondingly, in 3DS Max, each building element of the whole 3D model is modeled and saved in individual layers (Figure 41) in order to cover the requirements in the following physical data model. In particular, this is required for the successive assignment of each 3D object to the related class independently after the conversion/translation process. Accordingly, a simple convention is created for naming the layers, and it is thoroughly used in 3D modeling.



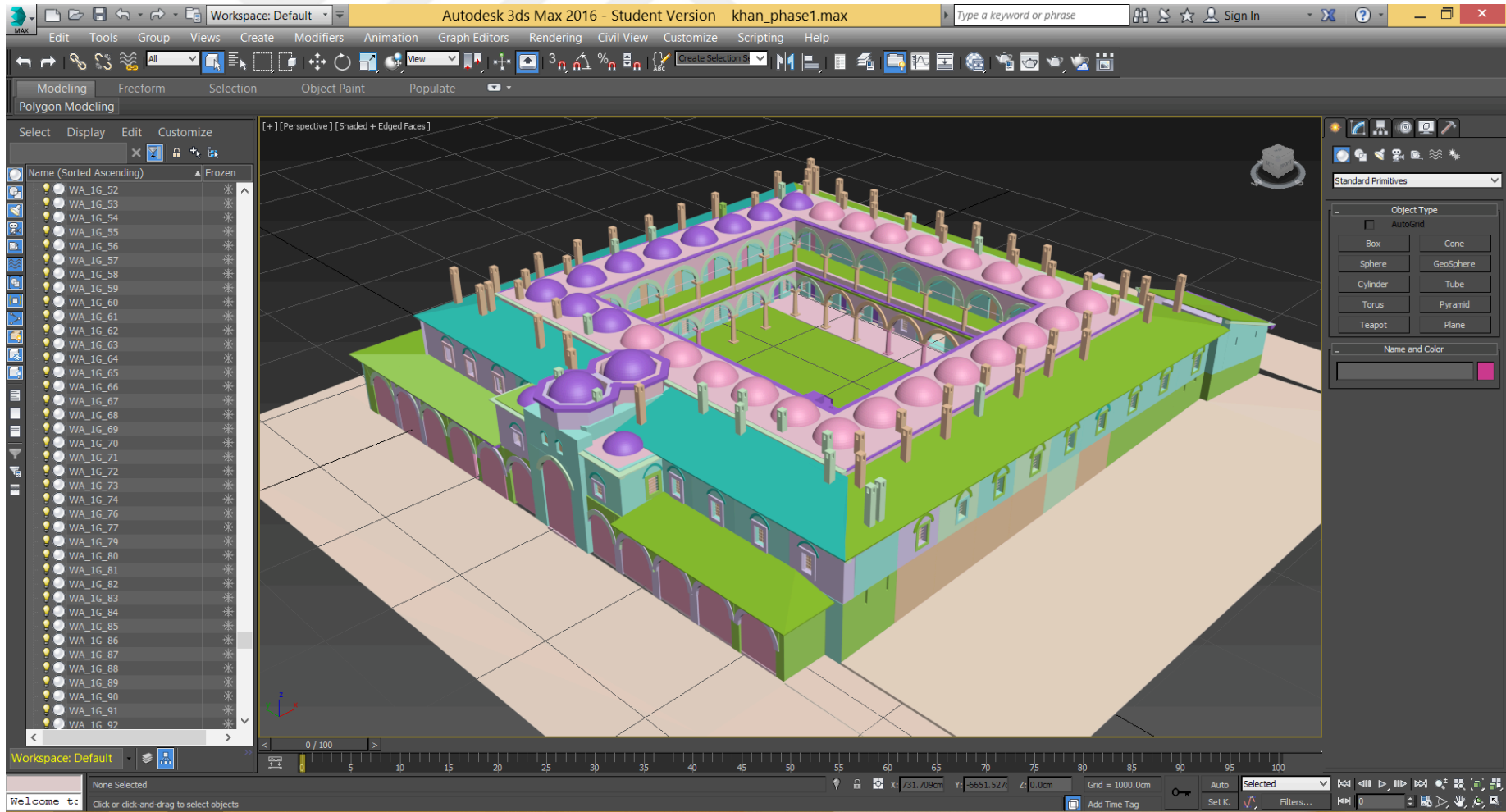

Figure 41. View of the 3D geometric model and layer system in Autodesk 3DS Max environment.

The naming of a layer is composed of numbers and letters, and designed in three parts divided by under scrolls as shown in Figure 42. 1<sup>st</sup> part of the name represents the class in which first two or three letters of each building element is used. 2<sup>nd</sup> part of the name consists both level and the temporal state information in two digits. First digit represents the temporal state by number in a chronological order, i.e., original state is shown by “1”, and the second digit of this part is for demonstrating the class-level relationship. Simple to the case, there are two alternatives, shown by the initial letter of belonging floor, i.e., “G” used as the first letter for the ground floor, whereas first floor is shown by “F”. The 3<sup>rd</sup> part of the name is any number, limited to three digits, in order to distinguish different objects within the same class. As an exemplification, “DOM\_1F\_012” is representing a dome on the first floor called by number 12 in the original state of *Kurşunlu* Khan. Lastly, it should be kept in mind that the name of any layer is limited to 10 digits. If there is an exceeding number of digits, some information might be lost during the successive data modeling phase.

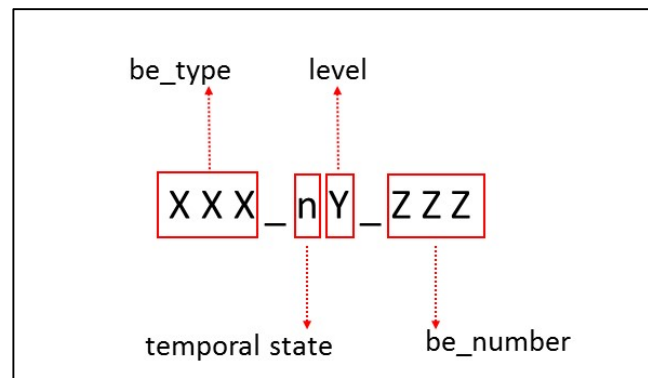

Figure 42. The structure of the naming used in 3D modeling process.

### **3.4.2.1. Generation of Building Elements for Successive Restitution States**

After modelling the geometries of each building in 3D, they need to be assembled in order to create a whole together for assigning the semantic information. By this process, it is possible to regenerate segmented 3D model for any restitution state. The building elements which remain original (unchanged), from one state to another, are preserved in 3D model. So, the original building elements which remain unchanged, whereas the changed ones are removed. Correspondingly, the original ones will continue to hold the same naming convention, and newly added geometries have new unique values according to their properties. Nevertheless, it should be kept in mind that this rule is only applied to the geometric modeling, when it comes to attributes, it is possible to assign different attributes to the same building element in different restitution states, although its geometry has not changed.

### **3.4.3. Logical Data Model**

Geometric modeling process is followed with the translation process thanks to the Feature Manipulation Engine (FME) by Safe Software Inc., which eliminates the major barrier due to the incompatible data formats. FME Workbench tool provides an efficient and automatic translation with a user-friendly graphic interface in order to visualize data-flow (Safe Software Inc. 2014). As a consequence, geometric data in .3ds format is read (extracted) and written (loaded) without any loss, for example from 3DS Max to the PostgreSQL/PostGIS database, or from the database to shapefile, or to any other common format.

The translation of the UML classes into relations, i.e., tables can be done in very different ways. First of all, it is important to define relations between tables. In order to do that, one should decide on data types, indexes (in order to speed up queries), and the concept of linking the tables together. This conceptual strategy developed for this research provides storage of different types of attributes with regard to class hierarchies (Figure 43).

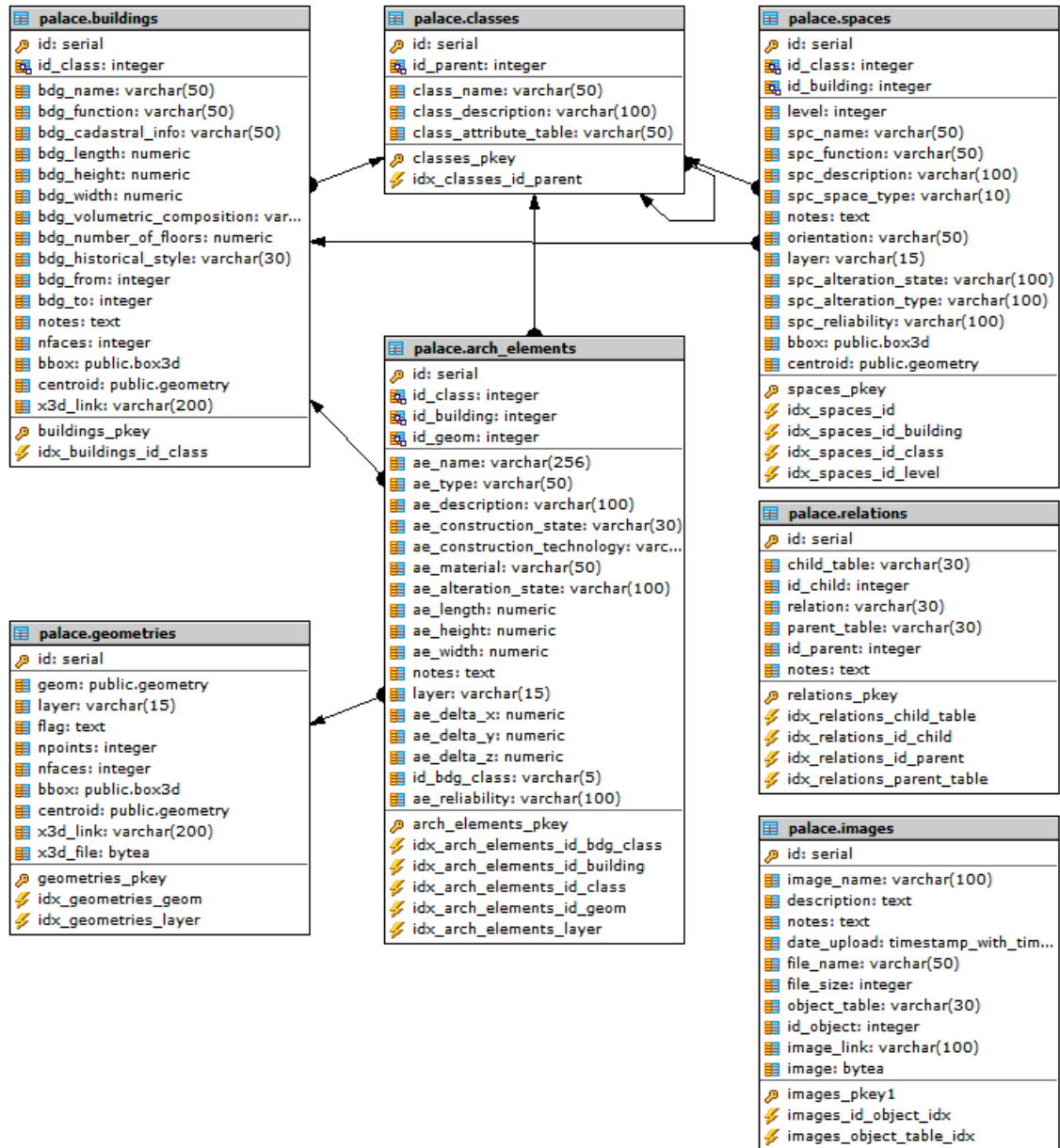

Figure 43. The logical data model used for the study.

Once the tables are decided, an important rule is to put only one piece of information (attribute) in each column. Besides, identification of constraints as uniqueness is important. Each attribute in a record must be atomic, it must be a single piece of data, not a collection of different data. In this case, each building element has a separate row and each piece of information is in a separate column.

In summary, a tablespace, as a logical data structure, is a conceptual view of the physical storage of the existing database is created. For the case study, the tables of “classes”, “building elements”, “geometries of building elements”, “spaces”, “building element – space relations”, and “restitution states”, which were produced in the logical data model are used in order to first create, and then to populate each with variety of attributes. As the data files are the hearth of the database system, storing all the information it should be noted that there are some critical points and rules to be considered in overall process: (i) Tables and columns must have meaningful but short names, which is a simple goal but challenging decision, (ii) there is no implied row order in a database table, (iii) another important point is the definition of the data types, e.g., integer (integer number), varchar (variable-text length), date, that goes to each column, (iv) the attributes called primary key is used in order to provide uniqueness to each record. “serial” is an integer that automatically set unique number for each row, which is used for id column, and (v) “null” is a special value, which means unknown at the moment or not relevant for the specific row (Matthew and Stones 2005).

#### **3.4.4. Physical Data Model**

The design of conceptual and logical data model is concerned on “what” question whereas, in the next step, i.e., physical data model is concerned on “how”. Accordingly, the design of the physical data model must be tailored to specific DBMS. Basically, a representation of the physical model contains the tables and their relationships.

The very first procedure is the creation of a new database, and all required database objects (schemas, tables, constraints, data types, etc.) with PostgreSQL and using the PostGIS spatial extension. On one hand, PostgreSQL is an advanced open-source database working with the relational database management concept (The

PostgreSQL Global Development Group 2014). On the other hand, PostGIS allows the use of special data types of geometric objects, and enables not only their storage but also manipulation and querying. The capability is not limited to only 2D primitives, e.g., points, lines, allows 3D geometries in the form of polyhedral surfaces and triangulated irregular network (TIN). Besides, it supports raster and vector data types. Another point is that PostGIS conforms to geographical and spatial data standards of Open Geospatial Consortium (OGC) (Obe and Hsu 2011). In short, adding GIS to PostgreSQL offers powerful features.

#### **3.4.4.1. Population of the Database**

The below listed principles are applied for the population of the database:

(a) The “classes” in which names, inheritances and descriptions are included comes automatically from the database schema.

(b) In the “building elements” table, first the “element name” (arch, vault, wall, etc.) and element type (structural, architectural or finishing) is included. Those are followed by construction technique and material usage. Those are all in varchar (variable-text length) format. Besides information about the element size (width, length, height) in metric units are also indicated. Nevertheless, it should be noted that they are not the exact measurements of the elements, but of bounding boxes defining each. Next, the restitution state is indicated. It is followed by the reliability level for restitution states, and alteration analysis only for as-found state. There are 3 options for the former as 1<sup>st</sup> degree reliable, 2<sup>nd</sup> degree reliable, 3<sup>rd</sup> degree reliable whereas the latter consist element addition, material addition, material replacement and removal.

(c) PostGIS allows to store geometric data, i.e., the “geometries of building elements” could be populated with geometries from the 3DS Max files. Moreover, the counting of number of points and faces for each 3D mesh is carried out.

(d) Populating the “spaces” table is a total manual process. It is belonging level can be an integer: 0 or 1, representing ground floor and first floor consequently. Relative space type is a varchar with value such as room, portico, courtyard, WC, etc. Enclosure quality is again a varchar with three values as open, semi-open or closed. Geographical location is again a varchar with values of North, South, East, and West.

(e) While building up the “building element-space” relations in PostgreSQL, the very first temporal state has to be manually inserted one by one for each segment. Besides, special attention must be paid as some segments might be shared ones, e.g., a wall facing to two adjacent spaces belong to both of them. As a consequence, two rows with same building element name can appear. This is to say that element is a shared one, and used for shaping more than one space due to the hybrid approach used.

After completing them all for a single restitution state, it is possible to continue with the others. We can keep the conceptual idea of regeneration in the 3D modeling process; however, there exist a new parameter different for relations in different restitution states. A building element and its naming convention might remain the same, i.e., it might remain unchanged so it can be cloned and re-used; nevertheless, it might belong to different spaces in different temporal states up due to the spatial transformation processes. So, for the relations of building element-space, it is only possible to clone and re-use relations for the spaces in which neither building elements are removed nor new elements are added. Besides, if a space has undergone through in any type of change (transformation, removal, conversion, etc.), then the new relations must manually be set.

(f) In the table of “restitution states”, function is varchar, as the building changed its function throughout the history, there will be various values of, mercantile, accommodation, jail, religious education, dormitory. Volumetric composition is Ottoman city khan with an inner square courtyard surrounded by colonnaded porticoes and rooms on two floors, from and to stands for the representation of time interval in integer.

(g) External data is a unique container for restitution states, it can be any data format such as pdf, tif, doc, ppt, etc. with inclusion of the descriptions.

### **3.4.5. Data Access and Visualization**

Data visualization is the presentation of data in a pictorial or graphical format. It enables decision makers to see analytics presented visually, so they can grasp difficult concepts or identify new patterns. With interactive visualization, one can take the concept a step further by using technology to drill down into charts and graphs for more detail, interactively changing what data you see and how it's processed. For the case

study, two main data visualization: first one is through ESRI ArcScene module of ArcGIS for visualization of semantically enriched 3D model, and second one is through a PHP-based web GUI for administration. Besides it is possible to visualize tabular data in Microsoft Excel.

To start with, it is possible to export data to ArcGIS and visualize them in 3D using ArcScene (Figure 44). By this way, it is possible to do a comparison of different restitution states and their reliability levels, and gather a critical interpretation.

From Appendix A to Appendix G consecutive restitution states are visualized in ArcGIS. In the upper section of the figure, restitution model is shown from two different angles, and below section is the visualization of the reliability as explored through the same model. Besides, 3 levels of reliability are assigned to those states as clarified in Section 2.7. Colors and transparency are used for easy detection. In particular, Appendix A is an exemplification of 3D visualization showing the restitution and its reliability of the original state (1498) of *Kurşunlu Khan*. Same principle is applied for the consecutive five states. Appendix B is the 3D visualization of the restitution of 2<sup>nd</sup> State (1643), below, red color represents 2<sup>nd</sup> degree reliability covering the repaired building elements following the earthquake, in particular, 12 arches on ground and first floors in Southern direction, and the windows and doors of the rooms. Other than that, the roof cover of the stable is shown in purple color representing the 3<sup>rd</sup> degree reliability. Appendix C is the 3D visualization of the restitution of 3<sup>rd</sup> State (1848), below, blue color represents 1<sup>st</sup> degree reliability covering the changes due to a repair campaign following a previous fire, in particular, replacement of roof covering, addition of drums below domes, reconstruction of the shops on the West with a longer depth, modification of the Western portal. Appendix D is the visualization of the restitution of 4<sup>th</sup> State (1908), below, red color again represents 2<sup>nd</sup> degree reliability covering the interventions due to the refunctioning of khan as a prison; in particular, transformation of the colonnaded portico into rooms by adding walls, doors, windows, and addition of a wooden shelter in the courtyard. Appendix E is the visualization of the restitution of 5<sup>th</sup> State (1954), below, blue color again represents 1<sup>st</sup> degree reliability covering the intervened parts, in particular, demolition of the shops, removal of a room and addition of a new gate, changes in the openings and application of plaster, all at the North direction. Appendix F is the visualization of the restitution of 6<sup>th</sup> State (1966-1970), and blue color represents 1<sup>st</sup> degree reliability covering the interventions of the restoration works, in particular, reconstruction of colonnaded portico including its



components: columns, vaults, domes, etc., reconstruction of the shops located on the West, replacement of casings of windows and doors, replacement of the roof covering, reconstruction of chimneys. Other than those above listed restitution states, it is possible to explore and visualize as-found state (2011) as shown in the upper part of Appendix G. In the below, alteration analysis is visualized with regard to its attributes: green color is assigned for element addition, orange color is assigned for material addition and pink color is assigned for material replacement.

Besides, it is possible to do queries through the semantically enriched 3D model. In this context, ArcGIS allows in two ways of query-based visualization: first, selecting by attributes for visualizing within the holistic model, and second the query builder for visualizing solely the corresponding building elements. Those are all based on information coming from the attribute tables. Correspondingly, it is possible to do queries according to building element name and type, material usage, element size, restitution state and its reliability. In order to exploit different query possibilities, some conservation-aimed examples are illustrated in the following. As an exemplification in Appendix H only the restitutive building elements which are structural as element type and have 2<sup>nd</sup> degree reliability are queried and visualized for the 3<sup>rd</sup> State (1848). In the next exemplification in Appendix J, only the restitutive building elements which are structural as element type, made of concrete, and have 1<sup>st</sup> degree reliability are queried and visualized for the 6<sup>th</sup> State (1966-1970). In the last exemplification of query is applied to the as-found state, only the element additions as alteration type are queried and visualized in Appendix K.

Other than above listed possibilities, it is also possible to click on an element and gather specific information on that element based on the attribute tables. Besides, it is possible to visualize images which are assigned to the nearest building element as sources of restitution for a better understanding. In Appendix L, identify option is applied to a wall part located on the northern direction, and both information on that building element and an archival photograph belonging to that façade could be visualized. In Appendix M, again identify option is applied to a restitutive building element within the colonnaded portico in order to understand how that space was converted, and both information on that building element, and archival photograph belonging to the colonnaded portico could be discovered. In the last example of Appendix N, a photograph showing the as-found state of colonnaded portico, and the corresponding building element could be visualized by the identify option.

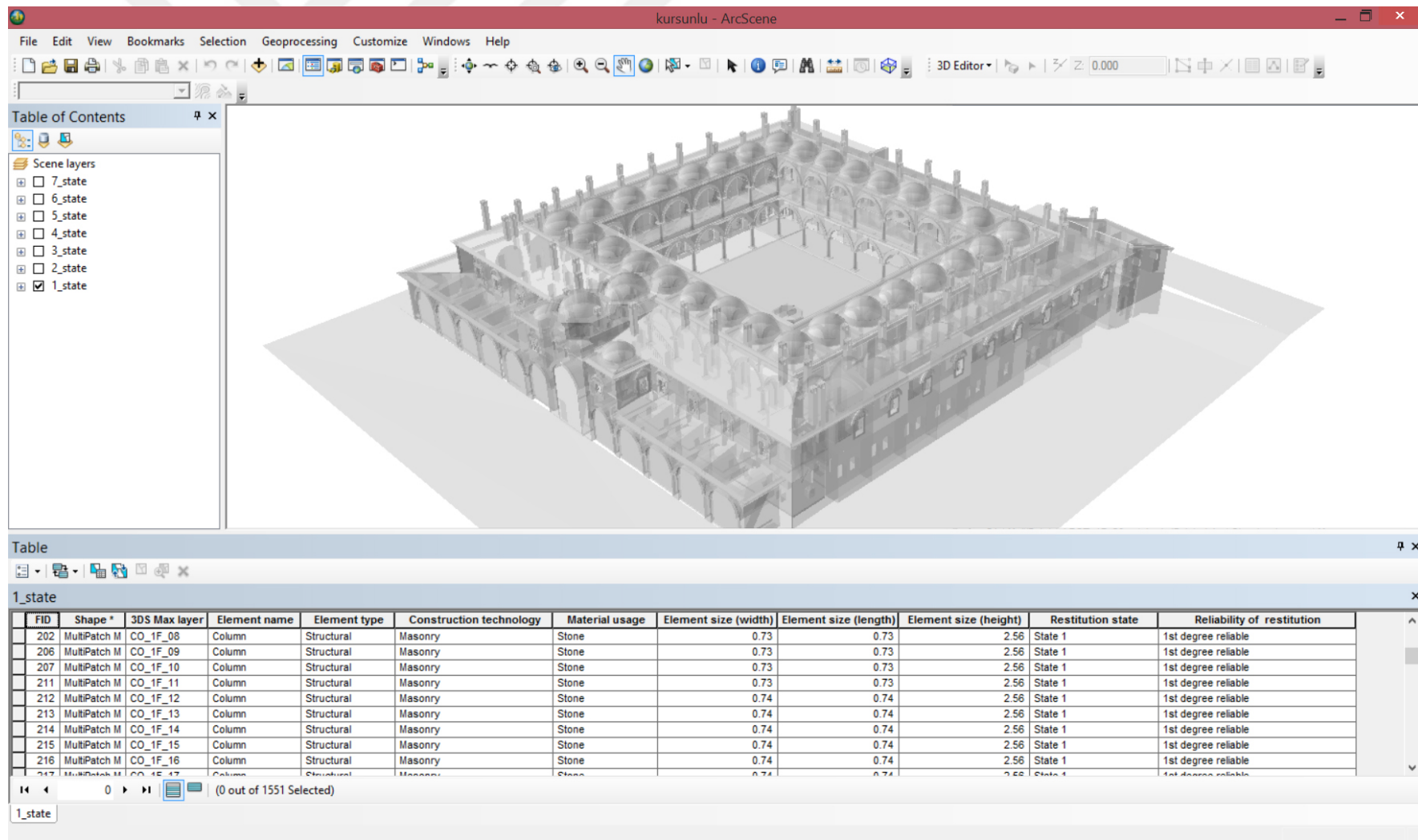

Figure 44. Example of visualization in ArcScene module of ArcGIS.

The second visualization possibility is through web-based platform thanks to a PHP-based web GUI allowing common and user-friendly interaction with PostgreSQL. Accordingly, it provides a browser-based interface for administration in a convenient way which can be reached through internet browser, and once accessed, it gives the ability to visualize, edit and export data from the database (in csv, pdf and xls). 3D model of each restitution state can be exported as X3D format to be visualized, e.g., in Meshlab. The X3D files contain only geometries, i.e., no attributes.

From within GUI, one can visualize different tables. Once accessed, one can visualize restitution states in the table of “temporal phases” (Figure 45), or individually view its information (Appendix P) by simply clicking view option next to each. Besides, a pull-down menu allows one to reach tables of spaces or images which are hierarchically related to the corresponding corresponding restitution state. In the table of “spaces per phase” (Appendix R) gives the opportunity to see list of spaces making up that restitution state. Besides, in that table one can simply visualize the list of building elements’ composing a specific space by opening pull-down menu attached to each as “building elements per space” (Appendix S).

Other than those, in the second tab within a specific restitution state there are “images per phase” in which photographs as sources specific to the corresponding restitution state can be explored (Appendix T).

Last, in the main page there is a tab named “external data” (Appendix U) in which sources of information, published and unpublished accounts, descriptions, and other archival documents are included. It gives the possibility to individually view each one as well (Appendix V).

In addition to above mentioned possibilities, it is possible to export data from PostgreSQL to Microsoft Excel, by means of a pgJDBC (Java Database Connectivity) interface, in order to exploit its well-known data analysis and functionalities for creating reports, generating graphs or charts. Yet, it should be noted that it is just a way of quantitative comparison of either building elements or spaces according to different parameters. Nevertheless, a historic building requires qualitative analysis then quantitative ones for understanding. Correspondingly, some data extraction possibilities are provided, but not aimed to cover overall aspects (Appendix Y). As an exemplification, (Figure 46) the spaces making up the 3<sup>rd</sup> State (1848) is evaluated according to the changes. Here, one can explore that spatial changes only occurred for entrance hall and the shops, which gives clues about the specific restitution state.

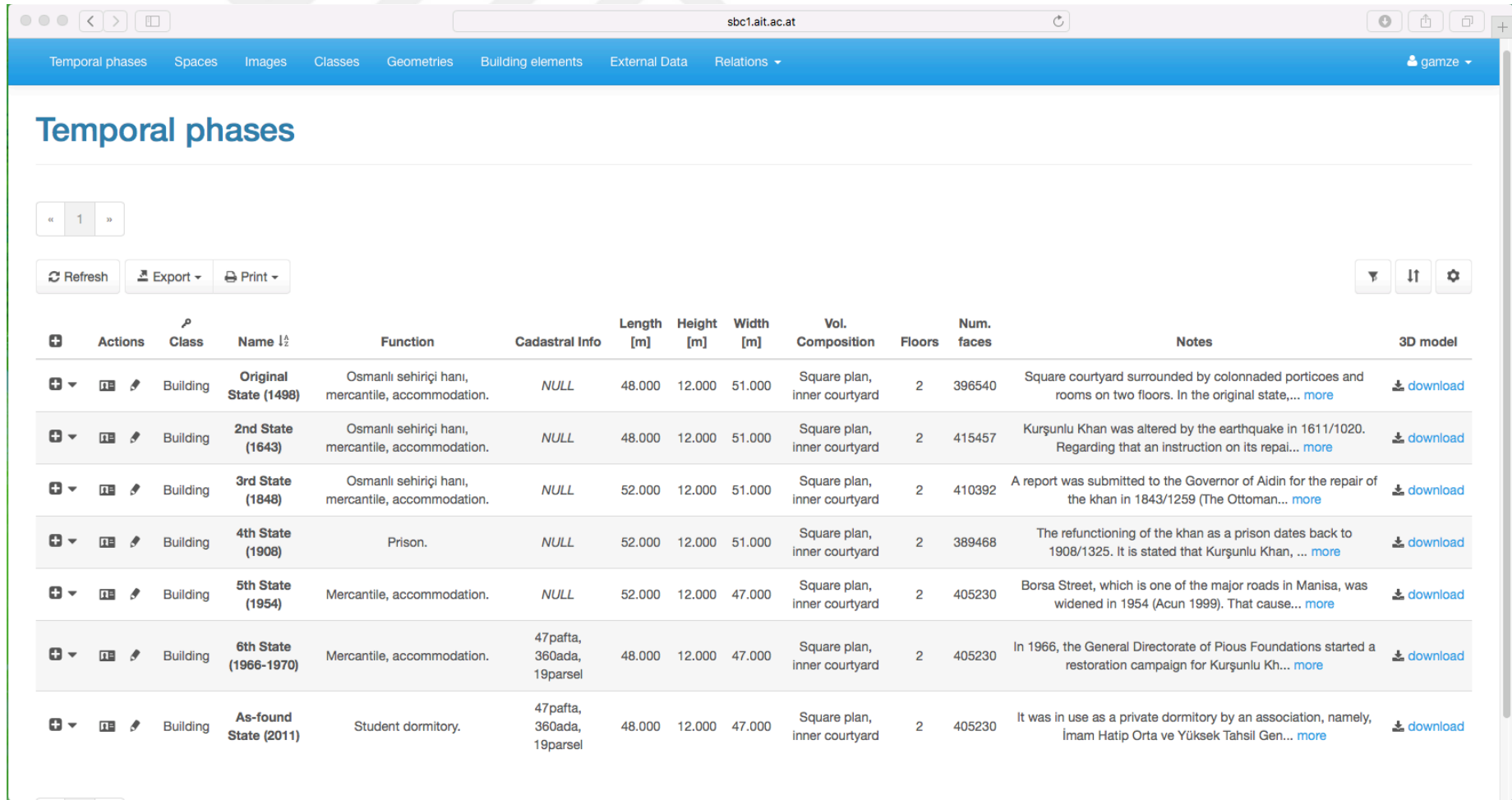

Temporal phases

| Actions | Class    | Name                  | Function   | Cadastral Info            | Length [m] | Height [m] | Width [m] | Vol. Composition             | Floors | Num. faces | Notes  | 3D model                 |
|---------|----------|-----------------------|--|---------------------------|------------|------------|-----------|------------------------------|--------|------------|--|--------------------------|
| +       | Building | Original State (1498) | Osmanlı sehirçi hani, mercantile, accommodation. | NULL                      | 48.000     | 12.000     | 51.000    | Square plan, inner courtyard | 2      | 396540     | Square courtyard surrounded by colonnaded porticoes and rooms on two floors. In the original state, ... <a href="#">more</a> | <a href="#">download</a> |
| +       | Building | 2nd State (1643)      | Osmanlı sehirçi hani, mercantile, accommodation. | NULL                      | 48.000     | 12.000     | 51.000    | Square plan, inner courtyard | 2      | 415457     | Kurşunlu Khan was altered by the earthquake in 1611/1020. Regarding that an instruction on its repai... <a href="#">more</a> | <a href="#">download</a> |
| +       | Building | 3rd State (1848)      | Osmanlı sehirçi hani, mercantile, accommodation. | NULL                      | 52.000     | 12.000     | 51.000    | Square plan, inner courtyard | 2      | 410392     | A report was submitted to the Governor of Aidin for the repair of the khan in 1843/1259 (The Ottoman... <a href="#">more</a> | <a href="#">download</a> |
| +       | Building | 4th State (1908)      | Prison.  | NULL                      | 52.000     | 12.000     | 51.000    | Square plan, inner courtyard | 2      | 389468     | The refunctoring of the khan as a prison dates back to 1908/1325. It is stated that Kurşunlu Khan, ... <a href="#">more</a>  | <a href="#">download</a> |
| +       | Building | 5th State (1954)      | Mercantile, accommodation.                       | NULL                      | 52.000     | 12.000     | 47.000    | Square plan, inner courtyard | 2      | 405230     | Borsa Street, which is one of the major roads in Manisa, was widened in 1954 (Acun 1999). That cause... <a href="#">more</a> | <a href="#">download</a> |
| +       | Building | 6th State (1966-1970) | Mercantile, accommodation.                       | 47pafta, 360ada, 19parsel | 48.000     | 12.000     | 47.000    | Square plan, inner courtyard | 2      | 405230     | In 1966, the General Directorate of Pious Foundations started a restoration campaign for Kurşunlu Kh... <a href="#">more</a> | <a href="#">download</a> |
| +       | Building | As-found State (2011) | Student dormitory.                               | 47pafta, 360ada, 19parsel | 48.000     | 12.000     | 47.000    | Square plan, inner courtyard | 2      | 405230     | It was in use as a private dormitory by an association, namely, İmam Hatip Orta ve Yüksek Tahsil Gen... <a href="#">more</a> | <a href="#">download</a> |

Figure 45. Web-based visualization of the database (restitution states)

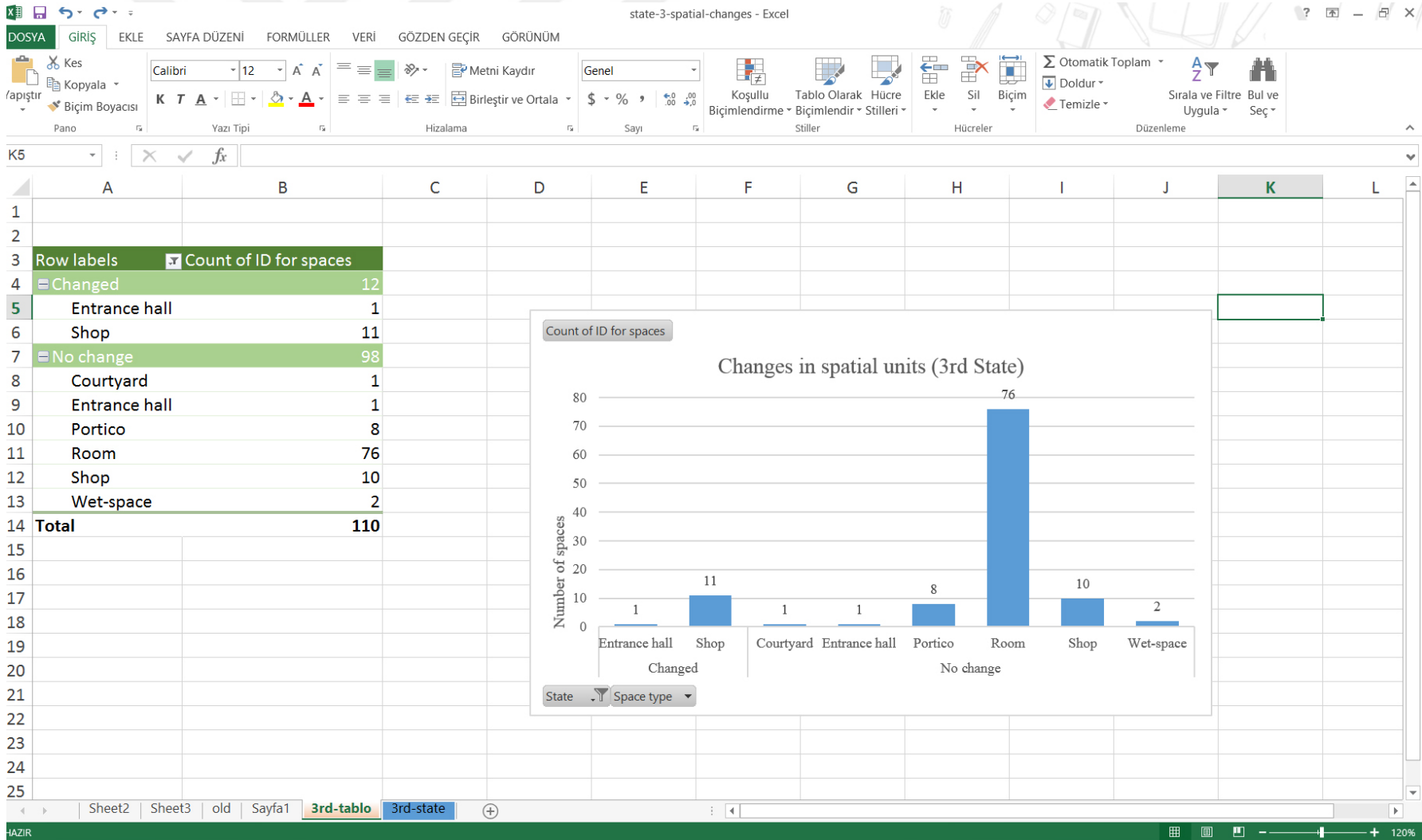

Figure 46. Example of the tabular data extraction.

## CHAPTER 4

### EVALUATION AND CONCLUSION

This thesis sought to integrate different information types regarding the restitution of a historic monument in a semantically enriched 3D model and create a database for efficient archiving, access and preservation of this model.

This chapter, which is bridging the inferences of the case study and the developed restitution database, is shaped in a multifold structure the first covers the (re)interpretation of *Kurşunlu Khan* deciphering its characteristics and values, the second points out the findings of the proposed methodology and includes not only the lessons learnt so far, but also pros and cons of the developed restitution database in order to understand and manage the case-specific issues and historic buildings, and third commands on future work.

#### 4.1. Evaluation of *Kurşunlu Khan*

The proposed restitution database is applied to a case study, *Kurşunlu Khan* in Manisa, Turkey as a specific building typology (*şehir içi hanları*) of the Ottoman Era dating back to 15<sup>th</sup> century, carrying specifications of the tradition, culture and architecture.

In the settlement scale, the character and the scale of Manisa did not change much from the beginning of 1500s until the second half of the 1800s. Nevertheless, at the end of the 1800s the city was denser, especially after the effects of railway construction reaching Manisa in 1866. In the same period cotton was a very important export good. Accordingly, new cotton processing factories were built. Besides, for its safe storage, new storehouses were constructed, which were specifically secured against any possible fire. This transformation in commerce and conversion in storage facilities caused a change in the commercial center, besides a new core had roused. The new

commercial center was at the Northern part of *Kurşunlu* Khan along the street connected to the railway station (Çetin 2012). The change also affected the life in the historical commercial center where traditional craftsmen were located. Besides, beginning with the 1830s, a different setup is encountered in which Ottoman craftspeople were confronted with the competition of European factory-made goods with the impact of industrial revolution (Faroqhi 2009).

In the building scale, *Kurşunlu* Khan used to keep its original function for which it was built for, before the industrial revolution and its impacts: the changes in the urban pattern and commercial center, and confrontation of the Ottoman craftspeople and merchants with it. It is found out that Jewish community were residing there in 16<sup>th</sup> and 17<sup>th</sup> centuries, and it was housing as a cereal market in the 16<sup>th</sup> century. Although there had been minor and major repairs in 1611, 1643, 1677 and 1848, and some interventions due to the man-made and natural causes (covering 1<sup>st</sup>, 2<sup>nd</sup> and 3<sup>rd</sup> states), it continued to accommodate the original material culture. The refunctioning of the khan as a prison dating back to 1908 (4<sup>th</sup> state), created a dramatic change both in its function, and in its spatial composition including the conversions of semi-open spaces to closed ones, and removal of various openings. Following that, in 1954 (5<sup>th</sup> state), the widening of Borsa Street, caused a slight change in the mass volume by the demolition of 11 shops of in the Northern direction. In 1966 (6<sup>th</sup> state), the restoration campaign was intended to be a positive contribution for covering the building's structural deficiencies and static weaknesses; nevertheless, the choice of concrete as the material was inappropriate. This was followed by unconscious interventions while the building was converted into a dormitory (7<sup>th</sup> state); however, the current restoration campaign aims to fulfill the requirements of an adequate conservation. Consequently, the physical structure of *Kurşunlu* Khan has undergone a series of alterations, transformations and conversions; nevertheless, the building structure could be preserved until today thanks to the durable materials in its construction.

Comparative study with other khans provided clues for the evaluation of the case within the period's architecture and style. The examples located in Tire, which is amongst important centers of Western Anatolia in that period, in particular, *Kutu* Khan (1429), *Çöplüce* Khan (1442), *Ali Efe* Khan (1525) and *Bakır* Khan (1543) is found different in the plan scheme. But, *Yeni* Khan (1543), which is a later example than the case, carries quite similarities in spatial solution and organization with the case

excluding the space for stable. In addition, the khans located on the same trade route are also compared with the case. *Taş Khan* (1432) in Bergama and *Taş Khan*(1600s) in Menemen, are similar in plan scheme, but they are both simpler and smaller in scale than *Kurşunlu Khan*, besides they have less number of rooms and no juxtaposing shop row(s). As a consequence, the khans located in the same region proved that *Kurşunlu Khan* had an advanced plan scheme corresponding to its construction period, and it is greater in scale including more spatial units (rooms and shops) than most. Besides, comparative study with the khans of the period's capital Bursa showed quite similarities in form like in the example of *Bey (Emir) Khan* (1339), *Gevye Khan* (1419) and *Koza Khan* (1491), that are all in Bursa, or *Pirinç Khan* (1508) in İstanbul. As a result, *Kurşunlu Khan* is amongst primary examples of *şehiriçi hanları* of the Ottoman Classical Style in Western Anatolia with identical architectural characteristics, in particular, the two floored ones, with an inner courtyard surrounded by a colonnaded portico.

The evaluation of political and socio-economic structure of Ottoman Empire showed that the construction process of *külliyes* and, its profit-earning components such as khans was part of the government strategy. Accordingly, the building itself is a particular representative of the Ottoman urban life in Manisa, i.e., implicates many values represent not only period's architecture and technology, but also its culture and economy. Besides, the building is an essential component which has contributed to the image of the cityscape while the life of the historic setting of Manisa is considered. As a consequence, *Kurşunlu Khan* has also documentary value as a type of construction of a traditional culture, architecture and land-use. As a matter fact, the building is a form of Ottoman culture and life-style representing a foster creativity and genuine dialogue (UNESCO 2001) of Ottoman era. It is a physical reality as a result of a creative process of humankind (Brandi 2005).

## **4.2. Findings of the Proposed Restitution Database**

The theoretical background on the topic is found promising and active, but still has limited perspective. It is found out that there exist only a few projects concerning the restitutions of single-scale historic buildings, and although using 3D model is a



standard practice, those models are generally limited into being raw ones or just digital images. Nonetheless, conservation-architects need intelligent 3D models which offers a user-friendly environment, and fast and efficient retrieval of information for understanding different restitution states throughout the history. This requires the storage of a huge-volume of geometric or non-geometric datasets, and the capability to manipulate and manage these datasets. Therefore, the professionals do not have to either choose a trend software which are limited concerning to the characteristics of restitution information.

In fact, a successful database must carry various abilities as holding the required data, supporting required data and specific relationships, solving problem, imposing data integrity and efficiency, accommodating of future changes. In the following, implemented methodology for the development of the restitution database is evaluated according to the aforementioned criteria:

- Identification process both covering the issues of architectural conservation and at the same time fulfilling the requirements of the universal frame of information technologies was compelling; nevertheless, it has been possible through the adaption of “reading” metaphor for the architecture of the building. In this process, each building element should be identified and their architectural properties (size, location, material, etc.) should be specified,
- Setting relationships and deciding which data structure suits the best for representing the building was quite compelling. A simple hierarchical structure working as a tree graph, building elements appearing as nodes is best suitable for the database of a historic monument.
- Restitution states should be defined and data corresponding to each should be classified,
- Finding shared ground with informatics has been quite hard. The definition of attributes and subtraction of what has been gathered and analyzed through the architectural and historical investigation in an abstract manner has been the solution.
- The 3D model which is enriched semantically should be composed of partitions representing building elements. But that, this model allowed to structure and semantically enrich data for the domain of cultural heritage in an innovative way, which represents an important contribution in the research area as the

researches are generally limited to outer envelope (mass volume) of the buildings for structuring restitution databases.

The implemented restitution database provides centralization of the geometric and non-geometric data in a single platform, so it allows complete digital archiving of restitution states. It is possible to reach restitution datasets through two interfaces: semantically enriched 3D model and web-based GUI.

First, the semantically enriched 3D model can be reached through ArcScene so it is software dependent. In this environment it is possible to do the inspection of the building stratigraphy through and application of diverse queries such as:

- 3D visualization of not only the building's original state, but also different restitution states in history (Appendix A to F),
- 3D visualization of reliability of restitution states, and their sources (Appendix L to M),
- Visualization of construction technique and material usage of the different states,
- Identifying the characteristics of components (either spaces or building elements),
- 3D visualization of alterations (element addition, material addition, material replacement) of the as-found state (Appendix G)
- Setting queries for a clear understanding (Appendix H to K).

Second, the tabular data can be reached through web-based GUI. It can be accessed through any internet browser, and it is kept in a server. Correspondingly, it is neither dependent on any hardware or software. Following can be explored in that environment:

- The list of restitution states, their content, and 3D geometric model of each (Appendix P),
- The list of spaces making up the restitution states (Appendix R),
- The list of building elements making up any space within a restitution state (Appendix S),
- Historic and legal documents and photographs related to the building's different restitution states as sources (Appendix T to V).

In addition, those data can be exported to Microsoft Excel and reports, graphs or charts can be generated (Appendix Y).

The database provides systematic archiving and access possibility for researchers interested in the historical periods of the case study monument. By this way, it supports decision-making process for future interventions appropriate to the qualities and characteristics of the heritage place. Correspondingly, data exploration and retrieval, which is a crucial step for understanding analysis, in the systemized and holistic environment gets easier and faster through the restitution database. As a consequence, the system not only allows the data management purpose, but also reuse of content and knowledge.

The proposed database provides a permanent and secure record of cultural heritage prior to any planned or unplanned changes. Data update, revision and correction is possible, which is important as the historic buildings are dynamic assets. As an exemplification, a new intervention, repair or restoration can occur on-site, or conservation-architects can reach to further documents or findings in the future, but all these changes can be added to the database.

Last but not least, the development of the proposed restitution database could be possible thanks to the interdisciplinary collaboration between architectural conservation, history, engineering and informatics. Dealing with technology and developing skills has been quite challenging; nevertheless, this is a part of the life-long learning process.

As a consequence, the restitution database proposed in this thesis is a sum of the (re)interpretation of the values and changes (Jokilehto 2006) specific to *Kurşunlu Khan*, reflecting the notion of Ottoman culture, way of life, workmanship, construction tradition and their continuity. The visualizations in terms of semantically enriched 3D model created in this research is neither just a volume of spaces nor geometric features, it is a holistic information container non-geometric data behind the imagery.

### **4.3. Direction for Future Studies**

First, the developed methodology is a prototype describing and implementing a methodological approach. Hence, the outcomes cover some of the crucial capabilities, but it should be noted that it is capable for enhancement with architectural conservation related information. Foremost importance, the spatial information is not covered about

the building elements in the study for the semantically enriched 3D model, nevertheless it carries importance for understanding the building. Correspondingly, it can be enhanced with such information. As another exemplification, the level of detail might be increased for the analysis of a historic building covering the structural deformations and their causes, and degree and type of material deteriorations. Other than that, the methodology can be expanded to any case-specific investigations or any other case studies' applications while the basics of the methodology will remain the same.

Second, the database is developed especially for conservation-architects as the primary actors in architectural heritage conservation allowing comprehensive understanding thanks to the holistic repository. Indeed, interpretation by general public is also quite important for public awareness as also underlined in the charters of ICOMOS. Correspondingly, a future research direction raises here in order to allow new levels of access, especially for public in order to develop conservation conscious and employ e-learning facilities.

Last, in future applications, the spatial modeling, in particular, manual 3D modeling effort by the adoption of the computer aided architectural design (CAAD) method, can be redesigned and replaced for the employment of digitally born 3D material based on digital data acquisition. This would require an extensive reevaluation of the segmentation process from whole to the parts, which is quite challenging but of great interest in today's research in the specific topic.

## BIBLIOGRAPHY

- Achille, C., Fassi, F., Fregonese, L. 2012. "4 Years history: From 2D to BIM for CH: The main spire on Milan Cathedral." *Proceedings of Virtual Systems in the Information Society 'VSMM'*. 377-382.
- Acun, Hakkı. 1999. *Manisa'da Türk Devri Yapıları*. Ankara: Türk Tarih Kurumu Basımevi.
- Agugiaro, G., F. Remondino, G. Girardi, J. von Schwerin, H. Richards-Rissetto, and R. De Amicis. 2011. "Queryarch3D: Querying and Visualising 3D Models of a Maya Archaeological Site in a Web-based Interface." *Geoinformatics FCE CTU Journal*, 6 10-17.
- Aktüre, Sevgi. 1975. "17. Yüzyıl Başından 19. Yüzyıl Ortasına Kadarki Dönemde Anadolu Osmanlı Şehrinde Şehirselleşme Süreci." *METU Journal of the Faculty of Architecture* 1: 101-124.
- . 1981. *19. Yüzyıl sonunda Anadolu kenti mekansal yapı çözümlemesi*. Ankara: ODTÜ Mimarlık Fakültesi Basım İşliğı.
- Apollonio, F.I., Gaiani, M., Zheng, S. 2012. "Bim-based Modeling and Data Enrichment of Classical Architectural Buildings." *SCientific RESearch and Information Technology*, 2(2) 41-62.
- Arayıcı, Y. 2008. "Towards Building Information Modelling for Existing Structures." *Structural Survey*, 26 (3) 210-222.
- ARK Insaat. 2011. *Kurşunlu Han Rölöve, Restitüsyon, Restorasyon Projesi*. Ankara.
- Armağan, Munis. 2005. *Anadolu Tarihinde Tire Yahudileri*. İzmir: Bilkar Bilge Karınca Matbaacılık.
- . 2003. *Devlet Arşivlerinde Tire*. İzmir: Bilge Karınca Matbaası.
- Attar, R., Prabhu, V., Glueck, M., Khan, A. 2010. "210 King Street: a dataset for integrated performance assessment." *Proceedings of the 2010 Spring Simulation Multiconference (SpringSim '10)*. San Diego, CA: International Society for Computer Simulation .
- Autodesk. n.d. *Framework for BIM implementation*. Accessed December 20, 2014. <http://www.autodesk.com/solutions/building-information-modeling/get-started>.
- Aydın, M. 1997. "Manisa." In *Eczacıbaşı Sanat Ansiklopedisi*, 1166-1167. İstanbul: Yapı Endüstri Merkezi.

- Ayverdi, E. Hakkı. 1966. *İstanbul mimari çağının menşe'i Osmanlı mimarisinin ilk devri: Ertuğrul, Osman, Orhan Gaziler, Hüdavendigâr ve Yıldırım Bayezid 630-805 (1230-1402)*. İstanbul: İstanbul Fetih Cemiyeti İstanbul Enstitüsü.
- . 1972. *Osmanlı mimarisinde Çelebi ve II.Sultan Murad devri 806-855 (1403-1451)*. İstanbul: İstanbul Fetih Cemiyeti İstanbul Enstitüsü.
- Baş, Ali. 1989. *Beylikler Dönemi Hanları*. Konya: Unpublished PhD Thesis (Selçuk Univ.).
- Baykara, Tuncer. 2015. *Anadolu'nun Tarihi Coğrafyasına Giriş I, Anadolu'nun idari taksimatı*. İstanbul: Bile Kültür Sanat.
- Boeykens, S., Himpe, C., Martens, B. 2012. "A Case Study of Using BIM in Historical Reconstruction: The Vinohrady synagogue in Prague." *Digital Physicality - Proceedings of the 30th eCAADe Conference*. Prague, Czech Republic. 729-737.
- Booch, Grady, James Rumbaugh, and Ivar Jacobson. 1999. *The Unified Modeling Language User Guide*. Redwood City, CA, USA: Addison Wesley Longman Publishing Co.
- Brandi, Cesare. 2005. *Theory of Restoration*. Translated by C. Rockwell.
- Cantay, Gönül. 1989. "Türkiye'de Osmanlı Devri Kervansaray Yapılarının Tipolojisi." *IX. Türk.Tarih Kongresi*. Ankara. 1381-1390.
- Centofanti, M., Continenza, R., Brusaporci, S., Trizio, I. 2011. "the Architectural Information System SIARCH3D-UNIVAQ for Analysis and Preservation of Architectural Heritage." *ISPRS Archives of Photogramm. Remote Sens. Spatial Inf. Sci.*, 38-5-W16.
- Cerasi, Maurice M. 1999. *Osmanlı Kenti, Osmanlı İmparatorluğu'nda 18. ve 19. Yüzyıllarda Kent Uygarlığı ve Mimari*. Translated by Aslı Ataöv. İstanbul: Yapı Kredi Kültür Sanat Yayınları.
- Cezar, Mustafa. 1983. *Typical commercial buildings of the Ottoman classical period and the Ottoman construction system*. İstanbul: Türkiye İşBankası Cultural Publications.
- Connolly, Thomas M., and Carolyn E. Begg. 2005. *Database Systems*. United States of America: Pearson Education Limited.
- Crosswell, P. 1991. "Obstacles to GIS Implementation and Guidelines to Increase Opportunities for Success." *Journal of the Urban and Regional Information Systems Association*, 3(1) 43-56.
- Çetin, Sıdıka. 2012/2. "Geç Osmanlıdan Erken Cumhuriyete İç Batı Anadolu'da Kentsel Yapının Değişimi: Manisa, Afyon, Burdur ve Isparta kentleri üzerine

- karşılaştırmalı bir inceleme (1)." *METU Journal of the Faculty of Architecture* 89-126.
- Çulcu, Sevinç. 2005. *Evaluation of alterations in Ottoman hans in Tire for their restitution*. İzmir: Unpublished Masters in Science Thesis (IYTE).
- Danforth, Nick. 2013. *Trains and telegrams*. February 07. Accessed February 10, 2016. <http://www.midafternoonmap.com/2013/02/trains-and-telegrams.html>.
- Dağlı, Yücel, and Seyit Ali Kahraman. 2007. *Evliya Çelebi Seyahatnamesi, Anadolu-Suriye-Hicaz, 1671-1672*. Vol. 9. İstanbul: Yapı Kredi Yayınları.
- De Luca, L., Busayarat, C., Stefani, C., Véron, P., Florenzano, M. 2011. "De Luca, L., Busayarat, C., Stefani, C., VA semantic-based platform for the digital analysis of architectural heritage." *Computers & Graphics*, 2(34) 227-241.
- De Luca, L., Bussarayay, C., Stefani, C., Véron, P., Florenzano, M. 2007. "An Integrated Framework to Describe, Analyze, Document and Share Digital Representations of Architectural Buildings." *Proceedings of The 8th International Symposium on Virtual Reality, Archaeology and Cultural Heritage VAST*. UK. 24-27.
- der Andreasyan, Hrant. 1964. *Polonyalı Simeon'un Seyahatnâmesi, 1608-1619*. İstanbul: İstanbul Üniversitesi.
- Dore, C., Murphy, M. 2012. "Integration of HBIM and 3D GIS for Digital Heritage Modelling." *Proceedings of Digital Documentation*. Edinburgh, Scotland.
- Eastman, C., Teicholz, P., Sacks, R., Liston, K. 2008. *Eastman, C., TeicBIM Handbook: A Guide to Building Information Modeling for Owners, Managers, Designers, Engineers and Contractors*. New Jersey, USA: John Wiley.
- Ekrem Hakkı Ayverdi, İ.Aydın Yüksel. 1976. *İlk 250 senenin Osmanlı Mimarisi*. İstanbul: Baha Matbaası.
- Eldem, Edhem, Daniel Goffmann, and Bruce Masters. 2012. *Doğu ile Batı Arasında Osmanlı Kenti - Halep, İzmir ve İstanbul*. İstanbul: Türkiye İş Bankası Kültür Yayınları.
- El-Hakim, Sabry, Lorenzo Gonzo, Francesca Voltolini, Stefano Girardi, Alessandro Rizzi, Fabio Remondino, and Emily Whiting. 2007. "Detailed 3D Modelling of Castles." *International Journal of Architectural Computing* 05 (02): 199-220.
- Elmasri, Ramez, and Shamkant B. Navathe. 2011. *Fundamentals of Database Systems*. 6th. Westford: Addison-Wesley.
- Emecen, Feridun. 2003. *Manisa*. Vol. 27, in *TDV İslâm Ansiklopedisi (DİA)*, 577-583. TDV İslâm Araştırmaları Merkezi.

- . 1997. *Unutulmuş bir Cemaat, Manisa Yahudileri*. İstanbul: Eren Yayıncılık.
- . 2013. *XVI. Asırda Manisa Kazası*. 2nd. Ankara: Türk Tarih Kurumu.
- Encyclopædia Britannica Online. 2016. *database*. Accessed January 2, 2016. <http://www.britannica.com/technology/database>.
- Ersoy, Bozkurt. 1991. *İzmir Hanları*. Ankara: Atatürk Kültür, Dil ve Tarih Yüksek Kurumu.
- Fai, S., Filippi, M., Paliaga, S. 2013. "Parametric modelling (BIM) for the documentation of vernacular construction methods: a BIM model for the commissariat building, Ottawa, Canada." *ISPRS Ann. Photogramm. Remote Sens. Spatial Inf. Sci.*, II-5/W1 115-120.
- Faroqhi, Suraiya. 2009. *Artisans of Empire, Crafts and Craftspeople Under the Ottomans*. London: I.B.Tauris & Co. Ltd.
- . 2008. *Osmanlı Kültürü ve Gündelik Yaşam, Ortaçağdan Yirminci Yüzyıla*. 6th Edition. İstanbul: Tarih Vakfı Yurt Yayınları.
- . 1994. *Osmanlı'da Kentler ve Kentliler*. 2nd. İstanbul: Tarih Türk Vakfı Yayınları.
- Feilden, Bernard M. 1994. *Conservation of Historic Buildings*. Boston: Architectural Press.
- Fowler, Martin. 2004. *UML Distilled: A Brief Guide to the Standard Object Modeling Language*. Boston, MA: Pearson Education.
- Gökçen, İbrahim. 1950. *Manisa Tarihinde Vakıflar ve Hayırlar (Hicri 1060, Miladi 1650den Sonra), Kitap II*. Manisa: Manisa Halkevi Yayınları.
- . 1946. *Manisa Tarihinde Vakıflar ve Hayırlar (Hicri 954-1060), Kitap I*. Manisa: Manisa Halkevi Yayınları.
- Günay, Reha. 2014. *Sinan the Architect and his Works*. İstanbul: Yapı Endüstri Merkezi.
- Güran, Ceyhan. 1976. *Türk hanlarının gelişimi ve İstanbul hanları mimarisi*. İstanbul: Vakıflar Genel Müdürlüğü.
- Gürel, Sümer. 1984. *Cumhuriyet Döneminde Manisa, Kent Monografisi Denemesi*. İzmir: Yaşar Eğitim ve Kültür Vakfı .
- Garagnani, S., and A.M. Manferdini. 2013. "Parametric accuracy: Building information modeling process applied to the cultural heritage preservation." *Proceedings of the 3D-ARCH 2013 – 3D Virtual Reconstruction and Visualization of Complex Architectures*. Trento, Italy.



- Genç, Mehmet. 2014. *Osmanlı İmparatorluğu'nda Devlet ve Ekonomi*. İstanbul: Ötüken Neşriyat.
- General Directorate of State Archives of the Prime Ministry. 1995. *166 Numaralı Muhasebe-i Vilayet-i Anadolu Defteri (937/1530), Hudavendigâr, Biga, Karesi, Saruhan, Aydın, Menteşe, Teke, Alaiye Livaları*. Ankara.
- General Directorate of State Archives of the Prime Ministry. n.d. *Ottoman Archive Catalogues*. İstanbul. Accessed 2015. <http://katalog.devletarsivleri.gov.tr/giris.aspx>.
- Gimenez, Lucile, Jean-Laurent Hippolyteb, Sylvain Roberta, Frédéric Suarda, and Khaldoun Zreikc. 2015. "Review: Reconstruction of 3D building information models from 2D scanned plans." *Journal of Building Engineering* (Elsevier) 2: 24-35.
- Goodwin, Godfrey. 1971. *A History of Ottoman Architecture*. Baltimore, USA: Johns Hopkins Press.
- Halpin, T., and T. Morgan. 2008. *Information Modeling and Relational Databases*. 2nd. MA, USA: Morgan Kaufmann Publishers, Elsevier.
- Hansar, Lilian. 2008. "The lacuna, an empty space in urban construction. Cesare Brandi's Restoration Theory in the integral preservation of old town area." *PLACE and LOCATION- Studies in Environmental Aesthetics and Semiotics*. Tallinn. 139-151.
- Hichri, N., Stefani, C., De Luca, L., Veron, P. 2013. "Review of the «as-built BIM» Approches." *ISPRS Archives of Photogramm. Remote Sens. Spatial Inf. XL-5/W1* 107-112.
- Hmida, H.B., Cruz, C., Boochs, F., Nicolle, C. 2012. "From Unstructured 3D Point Clouds to Structured Knowledge." In *Semantics - Advances in Theories and Mathematical Models*, edited by Afzal, 213-246. InTech Publisher.
- Üçel-Aybet, Gülgün. 2003. *Avrupalı Seyyahların Gözünden Osmanlı Dünyası ve İnsanları (1539-1699)*. İstanbul: İletişim Yayınları.
- ICOM/CIDOC Documentation Standards Group. 2013. *Definition of the CIDOC Conceptual Reference Model*. Vol. 5.1.2. Document. Edited by Martin Doerr, Christian Emil Ore, Stephen Stead Patrick Le Boeuf. <http://www.cidoc-crm.org>.
- ICOMOS. 2003. *Icomos Charter - Principles for the Analysis, Conservation and Structural Restoration of Architectural Heritage*. Victoria Falls: [http://www.icomos.org/charters/structures\\_e.pdf](http://www.icomos.org/charters/structures_e.pdf).

- ICOMOS. 2008. *ICOMOS Charter on the Interpretation and Presentation of Cultural Heritage Sites*. Québec, Canada, October 4. [http://www.icomos.org/charters/interpretation\\_e.pdf](http://www.icomos.org/charters/interpretation_e.pdf).
- ICOMOS. 1964. *International Charter for the Conservation and Restoration of Monuments and Sites (The Venice Charter)*. Venice, May 25-31. [http://www.icomos.org/charters/venice\\_e.pdf](http://www.icomos.org/charters/venice_e.pdf).
- ICOMOS. 1996. *Principles for the recording of monuments, groups of buildings and sites*. Sofia, October. <http://www.icomos.org/charters/archives-e.pdf>.
- ICOMOS. 1994. *The Nara Document on Authenticity*. Nara: <http://www.icomos.org/charters/nara-e.pdf>, November.
- İlter, İsmet. 1969. *Tarihi Türk Hanları*. Ankara: KGM Matbaası.
- İnalçık, Halil. 2015. *Devlet-i Aliye, Osmanlı İmparatorluğu Üzerine Araştırmalar-I*. İstanbul: Türkiye İş Bankası Kültür Yayınları.
- İnalçık, Halil. 1995. *Eyalet*. Vol. 11, in *TDV İslâm Ansiklopedisi (DİA)*, 548-550. TDV İslâm Araştırmaları Merkezi.
- İnalçık, Halil, and Donald Quataert. 1997. *An Economic and Social History of the Ottoman Empire*. Vols. 1: 1300-1600. Cambridge: Cambridge University Press.
- Ünsal, Behçet. 1959. *Turkish Islamic architecture: In Seljuk and Ottoman times 1071-1923*. London: Alec Tiranti.
- Jokilehto, Jukka. 2006. "Considerations on authenticity and integrity in world heritage context." *City & Time* 2 (1): 1-16.
- Köklü, Nusret. 1998. *Manisa İşgalden Kurtuluşa*. İzmir: Akademi Kitabevi.
- Köklü, Nusret. 1993/4. "Manisa Şehri İmar Planı Çalışmaları: 2." *Manisa Dergisi* 20-34.
- Kıray, Mübeccel. 1972. *Örgütlemeyen Kent İzmir*. Ankara: Bağlam Yayınları.
- Kolbe, T.H., and Plümer L. 2004. "Bringing GIS and CA(A)D Together - Integrating 3D city models emerging from two different disciplines." *GIM International*, 18 12-15.
- Kuban, Doğan. 2007. *Osmanlı Mimarisi*. İstanbul: Yem Yayın.
- Kuran, Apdullah. 1997. "Osmanlı Mimarlığı ve Sanatı." In *Eczacıbaşı Sanat Ansiklopedisi*, 1393-1399. İstanbul: Yapı Endüstri Merkezi.
- . 2012. *Selçuklular'dan Cumhuriyete Türkiye'de Mimarlık*. 1st. Edited by Çiğdem Kafesçioğlu, Lucienne Thys-Şenocak and Timur Kuran. İstanbul: İş Bankası Kültür Yayınları.

- Lefebvre, Henri. 2000. *The Production of Space*. London: Blackwell Publishers.
- Letellier, R. 2007. *Recording, Documentation and Information Management for the Conservation of Heritage Places*. Los Angeles, USA: The Getty Conservation Institute.
- Lewis, Rick, and Carlo Sequin. 1998. "Generation of 3D building models from 2D architectural plans." *Computer-Aided Design (Elsevier)* 30 (10): 765-779.
- London Charter. 2009. *The London Charter for the Computer-based Visualisation of Cultural Heritage*. <http://www.londoncharter.org/introduction.html>.
- Luther, Usha M. 1989. *Historical Route Network of Anatolia (İstanbul - İzmir - Konya) 1550's to 1850's: A Methodological Study*. Ankara: Türk Tarih Kurumu.
- Manferdini, A.M., and F. Remondino. 2012. "A review of reality-based 3D model generation, segmentation and web-based visualization methods." *Int. Journal of Heritage in the Digital Era, 1 (1)* 103-124.
- Matero, Frank M. 2005. "Loss, Compensation, and Authenticity: The Contribution of Cesare Brandi to Architectural Conservation in America." *Future Anterior IV (1)*: 45-58.
- Matthew, Neil, and Richard Stones. 2005. *Begining Databases with PostgreSQL, from Novice to Professional*. New York: Springer-Verlag.
- Moloo, Raj Kishen, Muhammad Ajmal Sheik Dawood, and Abu Salmaan Auleear. 2011. "3-Phase Recognition Approach to Pseudo 3D Building Generation from 2D Floor Plan." *International Journal of Computer Graphics & Animation* 1 (2): 13-27.
- Murphy, M., McGovern, E., Pavia, S. 2011. "Historic Building Information Modelling – Adding Intelligence to Laser and Image Based Survey." *Proceedings of the 4th ISPRS International Workshop, 38(5)*.
- Murphy, M., McGovern, E., Pavia, S. 2013. "Historic Building Information Modelling – Adding intelligence to laser and image based surveys of European classical architecture." *ISPRS Journal of Photogrammetry and Remote Sensing, 76* 89-102.
- Necipoğlu, Gülru. 2007. "Creation of a National Genius: Sinan and the Historiography of "Classical" Ottoman Architecture." *Muqarnas Vol. 24, History and Ideology: Architectural Heritage of the "Lands of Rum"* 141-183.
- Necipoğlu, Gülru. 1986. "Plans and Models in 15th and 16th Century Ottoman Architectural Practice." Edited by University of California Press. *Journal of the Society of Architectural Historians* 45: 224-243.

- Obe, Regina O., and Leo S. Hsu. 2011. *PostGIS in Action*. Stamford, CT: Manning Publications.
- Ogleby, Clifford. 2007. "Ancestral Art." In *Recording, Documentation and Information Management for the Conservation of Heritage Places*, edited by Eppich R. and Chabbi A. LA: Getty Conservation Institute.
- Or, Siu-hang, Kin-Hong Wong, Ying-kin Yu, and Michael Ming-yuan Chang. 2005. "Highly Automatic Approach to Architectural Floorplan Image Understanding & Model Generation." *Proceedings of Vision, Modeling, and Visualization, Pattern Recognition*. Erlangen, Germany: IOS Press. 25-32.
- Orbaşlı, Aylın. 2008. *Architectural Conservation*. United Kingdom: Blackwell Publishing.
- Oreni, D., Brumana, R., Cuca, B. 2012. "Towards a methodology for 3D content models: The reconstruction of ancient vaults for maintenance and structural behaviour in the logic of BIM management." *Proceeding of Virtual Systems in the Information Society 'VSMM'*.
- Oreni, D., Brumana, R., Georgopoulos, A., Cuca, B. 2013. "HBIM for conservation and management of built heritage: Towards a library of vaults and wooden beam floors." *ISPRS Ann. Photogramm. Remote Sens. Spatial Inf. Sci., II-5/W1* 49-54.
- Ortaylı, İlber. 2008. *Türkiye Teşkilat ve İdare Tarihi*. Ankara: Boyut Matbaası.
- Ostrogorsky, Georg. 1981. *Bizans Devleti Tarihi*. Translated by Fikret Işıltan. Ankara: Türk Tarih Kurumu Yayınları.
- Oğuz, Filiz. 1974. "Manisa Kurşunlu Han." *Rölöve ve Restorasyon Dergisi*, January 1: 109-128.
- Ödekan, A. 1997. "Küllüye." In *Eczacıbaşı Sanat Ansiklopedisi, 1075-1077*. İstanbul: Yapı Endüstri Merkezi.
- Öney, Gönül. 2002. *Akdeniz'de İslam Sanatı: Erken Osmanlı Sanatı Beyliklerin Mirası*. İstanbul: Arkeoloji ve Sanat Yayınları.
- Özdeş, Gündüz. 1953. *Türk Çarşıları*. İstanbul: Pulhan Matbaası.
- Özkan, Fatma. 1994. *Menemen research of the historical environment proposals concerning the preservation and restoration*. İzmir: Unpublished Masters in Science Thesis (DEU).
- Pınar, İlhan. 1998. *Richter, Otto Friedrichs von Richter: Manisa (1815)*. İzmir: Akademi Kitabevi.
- Pamuk, Şevket. 2015. *Osmanlı-Türkiye İktisadi Tarihi 1500-1914*. İstanbul: İletişim Yayınları.

- Peeters, Jacob. 1685. *Description des principales Villes, Havres et Isles du Golfe de Venise du cote' Oriental, comme aussi des Villes et Forteresses de la Moree et quelques Places de la Grece et des Isles principales de l'Archipel et Forteresses d'jcelles et en Suite quelques Places renommées de la Terre Saincte, et autres dessous la Domination Ottomanne vers le Midy et l'Orient, et quelques principales Villes en Perse et le Regne du Grand Mogol.* [http://digital.bib-bvb.de/webclient/DeliveryManager?custom\\_att\\_2=simple\\_viewer&pid=634585](http://digital.bib-bvb.de/webclient/DeliveryManager?custom_att_2=simple_viewer&pid=634585)  
2. Anvers.
- Peirce, Leslie P. 1993. *The Imperial Harem, Women and Sovereignty in Ottoman Empire.* USA: Oxford University Press.
- Pitcher, Donald Edgar. 1972. *An Historical Geography of the Ottoman Empire.* Leiden: E.J.Brill.
- Pu, S., Vosselman, G. 2006. "Automatic extraction of building features from terrestrial laser scanning." *ISPRS Archives of Photogramm. Remote Sens. Spatial Inf. Sci.*, 36 (5) 25-27.
- Quataert, Donald. 2005. *The Ottoman Empire, 1700–1922.* 2nd. Cambridge: Cambridge University Press.
- Ramakrishnan, Raghu, Johannes Gehrke, Jeff Derstadt, Scott Selikoff, and Lin Zhu. 2002. *Database Management Systems Solutions Manual.* Madison: The University of Wisconsin.
- Ramsay, William Mitchell. 1890. *The Historical Geography of Asia Minor.* London: John Murray.
- Revett, Nicholas. 1971. *Richard Chandler: Travels in Asia Minor, 1764-1765.* London: The Trustees of the British Museum.
- Roth, Leland M. 2007. *Understanding Architecture.* Colorado: Westview Press.
- Rusu, R., Marton, Z., Blodow, N., Holzbach, A., Beetz, M. 2009. "Model-based and learned semantic object labeling in 3D point cloud maps of kitchen environments ." *Proceedings of IEEE/RS International Conference on Intelligent Robots and Systems (IROS).* 3601-3608.
- Süllü, Tekin. 2010. "Manisa Kurşunlu Han Sanat Tarihi Raporu."
- Safe Software Inc. 2014. *Getting Started with FME® Desktop.* Canada. <http://docs.safe.com/fme/pdf/FMEGettingStarted.pdf>.
- San José-Alonso, J.I., Finat, J., Pérez-Moneo, J.D., García, M., Fernández-Martín, J.J., Martínez-Rubio J. 2009. "Information and knowledge systems for integrated

models in Cultural Heritage." *ISPRS Archives of Photogramm. Remote Sens. Spatial Inf. Sci.*, 38 (5).

Saygı, Gamze. 2015. "Photographic archive."

Saygı, Gamze, and Fabio Remondino. 2013. "Management of Architectural Heritage Information in BIM and GIS: State-of-the-art and Future Perspectives." *International Journal of Heritage in the Digital Era* 2 (4): 695-713.

Saygı, Gamze, Giorgio Agugiaro, Mine Hamamcıoğlu-Turan, and Fabio Remondino. 2013. "Evaluation of GIS and BIM roles for the information management of historical buildings." *ISPRS Annals of the Photogrammetry, Remote Sensing and Spatial Information Sciences* 283-288.

Shaw, Stanford. 1976. *History of the Ottoman Empire and Modern Turkey*. Vol. 1. Cambridge: Cambridge University Press.

Şahin, İlhan. 2009. *Sancak*. Vol. 36, in *TDV İslâm Ansiklopedisi (DİA)*, 97-99. TDV İslam Araştırmaları Merkezi.

Tükel-Yavuz, Aysil. 1997. "The Concepts that Shape Anatolian Seljuq Caravanserais." *Muqarnas XIV: An Annual on the Visual Culture of the Islamic World* 80-95.

The Archives of National Directorate of Pious Foundations. n.d. "Endowment Charter of Hatuniye Mosque dating 1497." In *book number 608/1*, 211-224.

The PostgreSQL Global Development Group. 2014. *PostgreSQL 9.3.5 Documentation*. California, USA. <http://www.postgresql.org/files/documentation/pdf/9.3/postgresql-9.3-A4.pdf>.

Tunçoku S., Aktaş. 2014. "RES 502 Design in Architectural Restoration II." Izmir Institute of Technology.

Turan, Şerafettin. 2005. "Mimarbaşı." In *TDV İslam Ansiklopedisi, Vol.30*, 90-91. TDV İslâm Araştırmaları Merkezi.

Turner, Eric, and Avidah Zakhor. 2014. "Floor Plan Generation and Room Labeling of Indoor Environments from Laser Range Data." In *Communications in Computer and Information Science*, edited by Simone Barbosa. Springer.

Uluçay, Çağatay, and İbrahim Gökçen. 1939. *Manisa Tarihi*. İstanbul.

Uluçay, M. Çağatay. 1946. *Saruhan oğulları ve eserlerine dair vesikalar*. İstanbul: Resimli Ay Matbaası.

—. 1942. *XVII. Asırda Manisa'da Ziraat, Ticaret ve Esnaf Teşkilatı*. İstanbul: Resimli Ay Matbaası.

- Uluengin, Fatih, Bülent Uluengin, and M. Bengü Uluengin. 2014. *Osmanlı Anıt Mimarisinde Klasik Yapı Detayları*. İstanbul: Yem Yayın.
- UNESCO. 2003. *Charter on the Preservation of Digital Heritage*. Paris: [http://portal.unesco.org/en/ev.php-URL\\_ID=17721&URL\\_DO=DO\\_TOPIC&URL\\_SECTION=201.html](http://portal.unesco.org/en/ev.php-URL_ID=17721&URL_DO=DO_TOPIC&URL_SECTION=201.html).
- UNESCO. 2001. *Universal Declaration on Cultural Diversity*. Paris: <http://unesdoc.unesco.org/images/0012/001246/124687e.pdf#page=67>, November 2.
- Uzunçarşılı, İsmail Hakkı. 1984. *Anadolu Beylikleri ve Akkoyunlu, Karakoyunlu Devletleri*. Ankara: Türk Tarih Kurumu Basımevi.
- von Meiss, Pierre. 2011. *Elements of Architecture, from Form to Space*. USA: Routledge.
- von Shwerin, Jennifer, Heather Richards-Rissetto, Fabio Remondino, and Giorgio Aguiaro. 2013. "The MayaArch3D project: A 3D WebGIS for analyzing ancient architecture and landscapes." *Literary and Linguistic Computing*.
- Vosselman, G., Gorte, B.G.H., Sithole, G., Rabbani, T. 2004. "Recognising structure in laser scanner point clouds." *ISPRS Archives of Photogramm. Remote Sens. Spatial Inf. Sci.*, 46 (8) 33-38.
- Watenpaugh, Heghnar Zeitlian. 2004. *The Image of an Ottoman City*. Netherlands: Brill.
- Whiteman, Michael. 1967. *Philosophy of space and time and the inner constitution of nature : a phenomenological study*. New York: Humanities Press.
- Wittek, P. 1931. *Rudolf Meyer Riefstahl: Turkish architecture in south-western anatolia*. Cambridge: Harvard University Press.
- Xiong, X., Huber, D. 2010. "Using Context to Create Semantic 3D Models of Indoor Environments." *Proceedings of the British Machine Vision Conference*. BMVA Press. 45.1-45.11.
- Yüksel, İ. Aydın. 1983. *Osmanlı Mimarisinde II.Beyazıd, Yavuz Selim Devri* . Vol. 5. İstanbul.
- Yajing, D., Cong W. 2011. "Research on the Building Information Model of the stone building for heritages conservation with the outer south gate of the Ta Keo Temple as an example." *Proceedings of International Conference on Electric Technology and Civil Engineering (ICETCE)*. 1488-1491.
- Yalçınar, G. 1997. "Han." In *Eczacıbaşı Sanat Ansiklopedisi*, 753-754. İstanbul: Yapı Endüstri Merkezi.

- Yavaş, Doğan. 2002. *Kurşunlu Han*. Vol. 26, in *TDV İslâm Ansiklopedisi (DİA)*, 448. TDV İslâm Araştırmaları Merkezi.
- Yerasimos, Stefanos. 2005. *Joseph Pitton de Tournefort Seyahatnamesi*. İstanbul: Kitap Yayınevi.
- Yeung, Albert K.W., and G. Brent Hall. 2007. *Spatial Database Systems: Design, Implementation and Project Management*. Dordrecht, The Netherlands: Springer.
- Yin, Xuetao, Peter Wonka, and Anshuman Rozdam. 20-30. "Generating 3D Building Models from Architectural Drawings: a Survey." *IEEE Computer Graphics and Applications* 2009.
- Yue, K., Huber, D., Akinci, B., Krishnamurti, R. 2006. "The ASDMCon project: The challenge of detecting defects on construction sites." *Proceedings of the Third International Symposium on 3D Data Processing, Visualization and Transmission (3DPVT)*. 1048-1055.



# APPENDIX A

## VISUALIZATION OF THE ORIGINAL STATE (1498) IN ARCSCENE MODULE OF ARCGIS

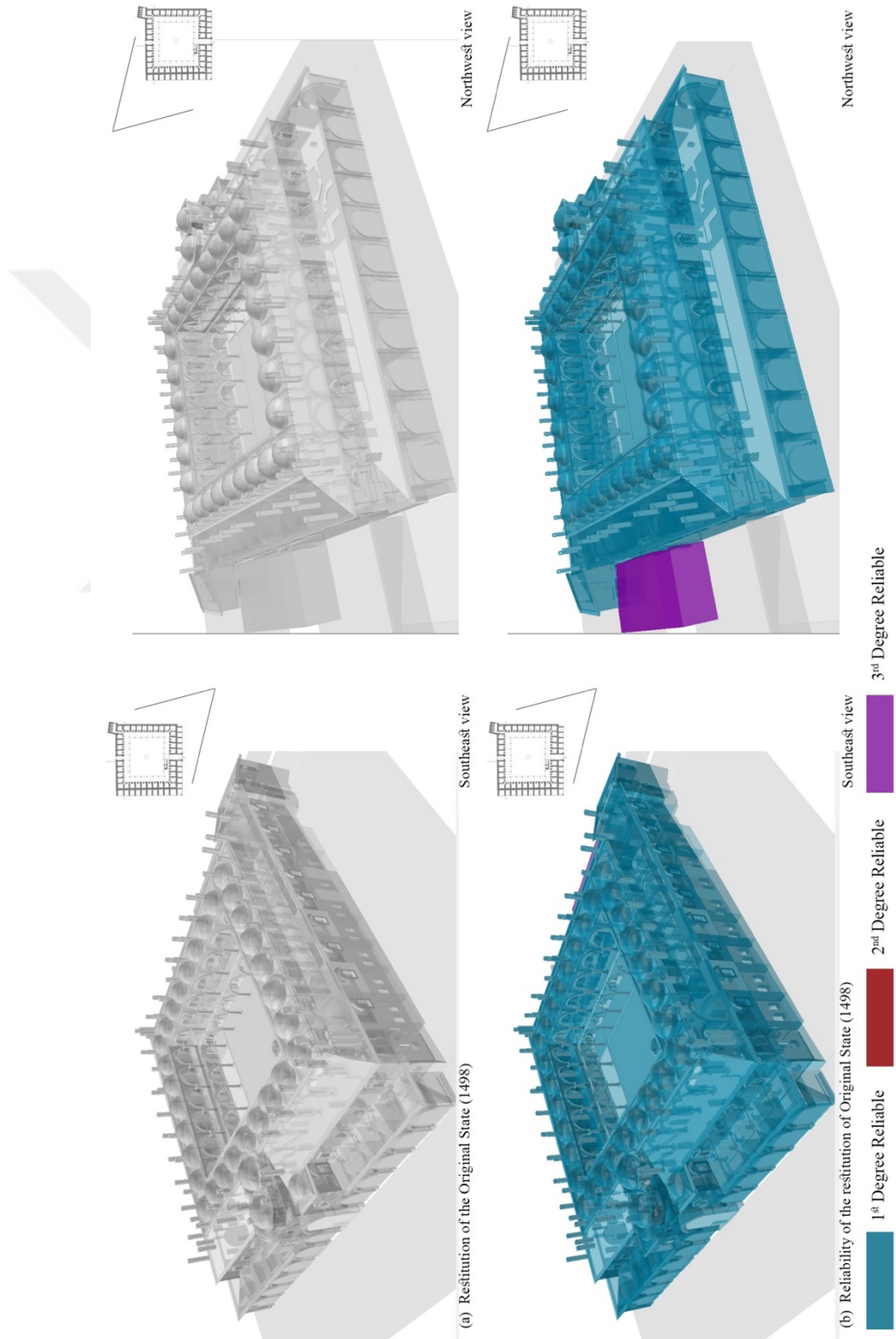

# APPENDIX B

## VISUALIZATION OF THE 2<sup>nd</sup> STATE (1643) IN ARCSCENE MODULE OF ARCGIS

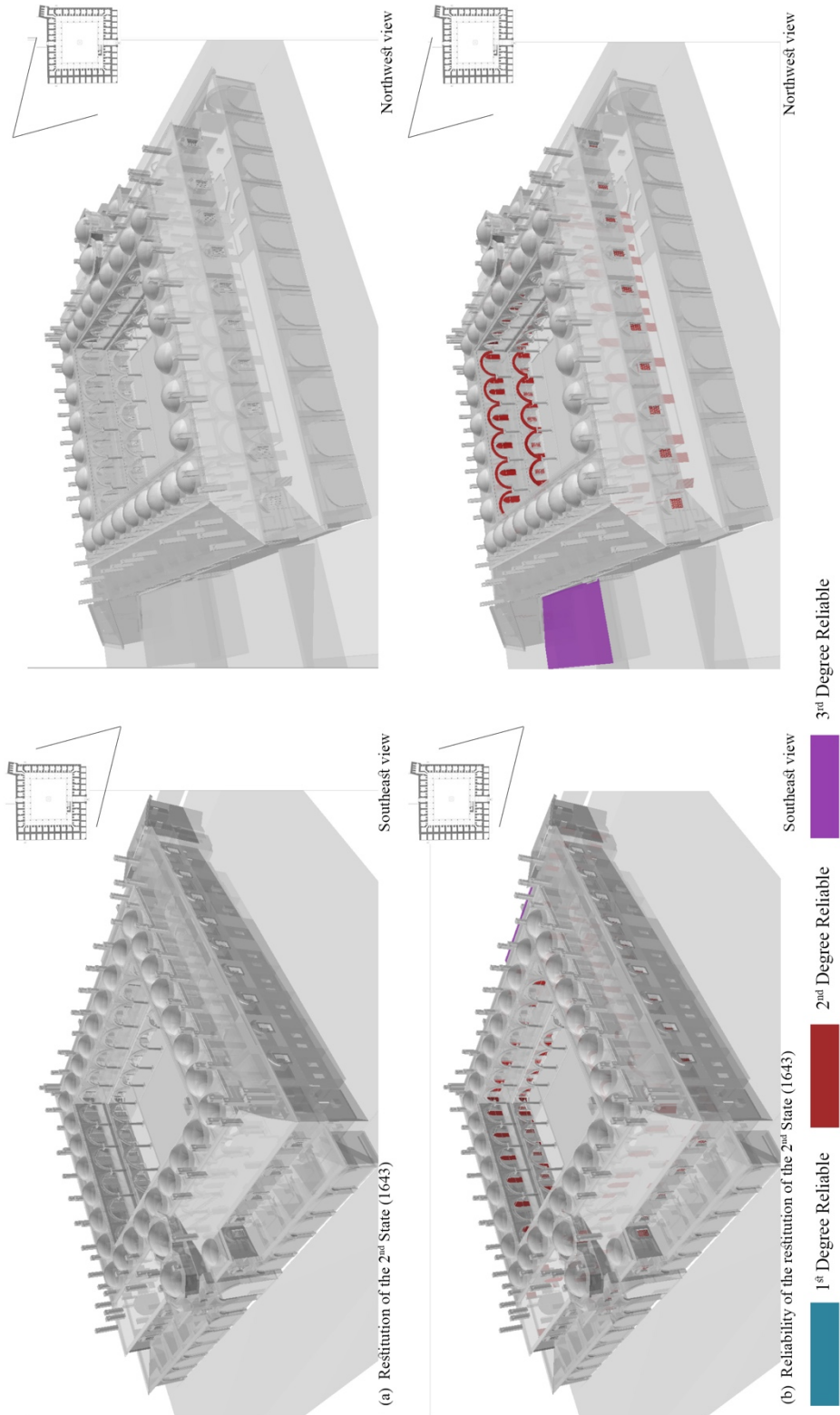

# APPENDIX C

## VISUALIZATION OF THE 3<sup>rd</sup> STATE (1848) IN ARCSCENE MODULE OF ARCGIS

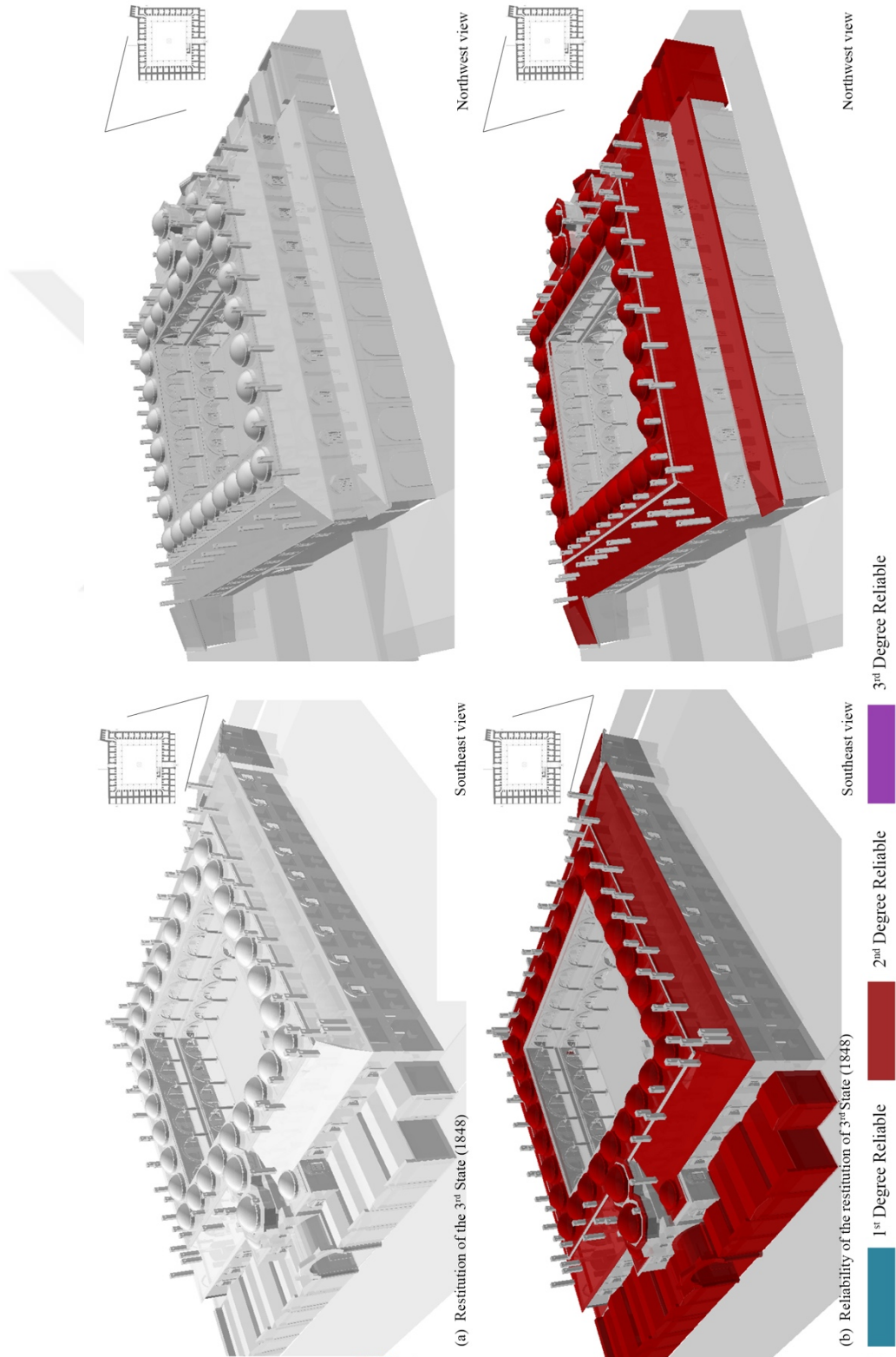

# APPENDIX D

## VISUALIZATION OF THE 4<sup>th</sup> STATE (1908) IN ARCSCEEN MODULE OF ARCGIS

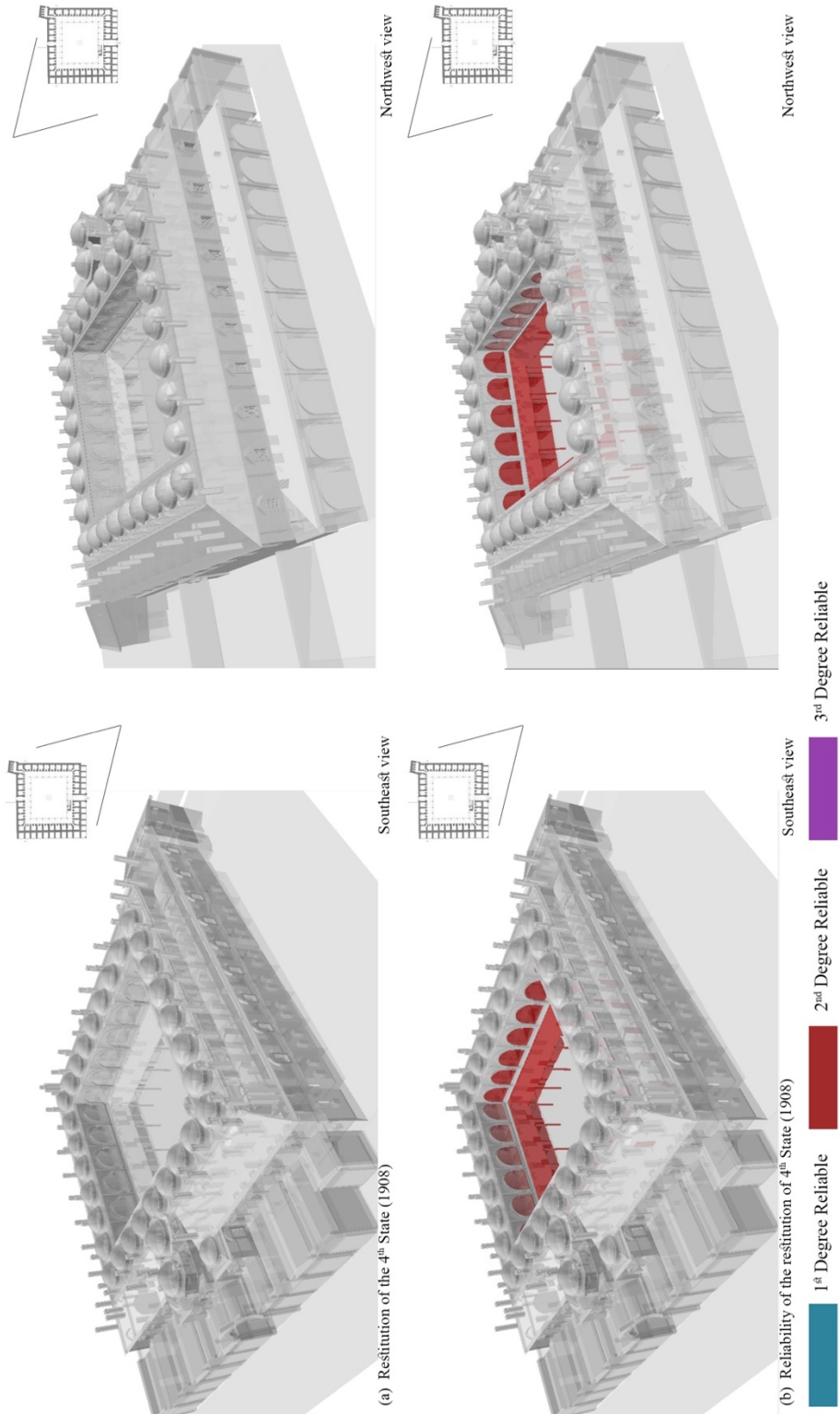

# APPENDIX E

## VISUALIZATION OF THE 5<sup>th</sup> STATE (1954) IN ARCSCENE MODULE OF ARCGIS

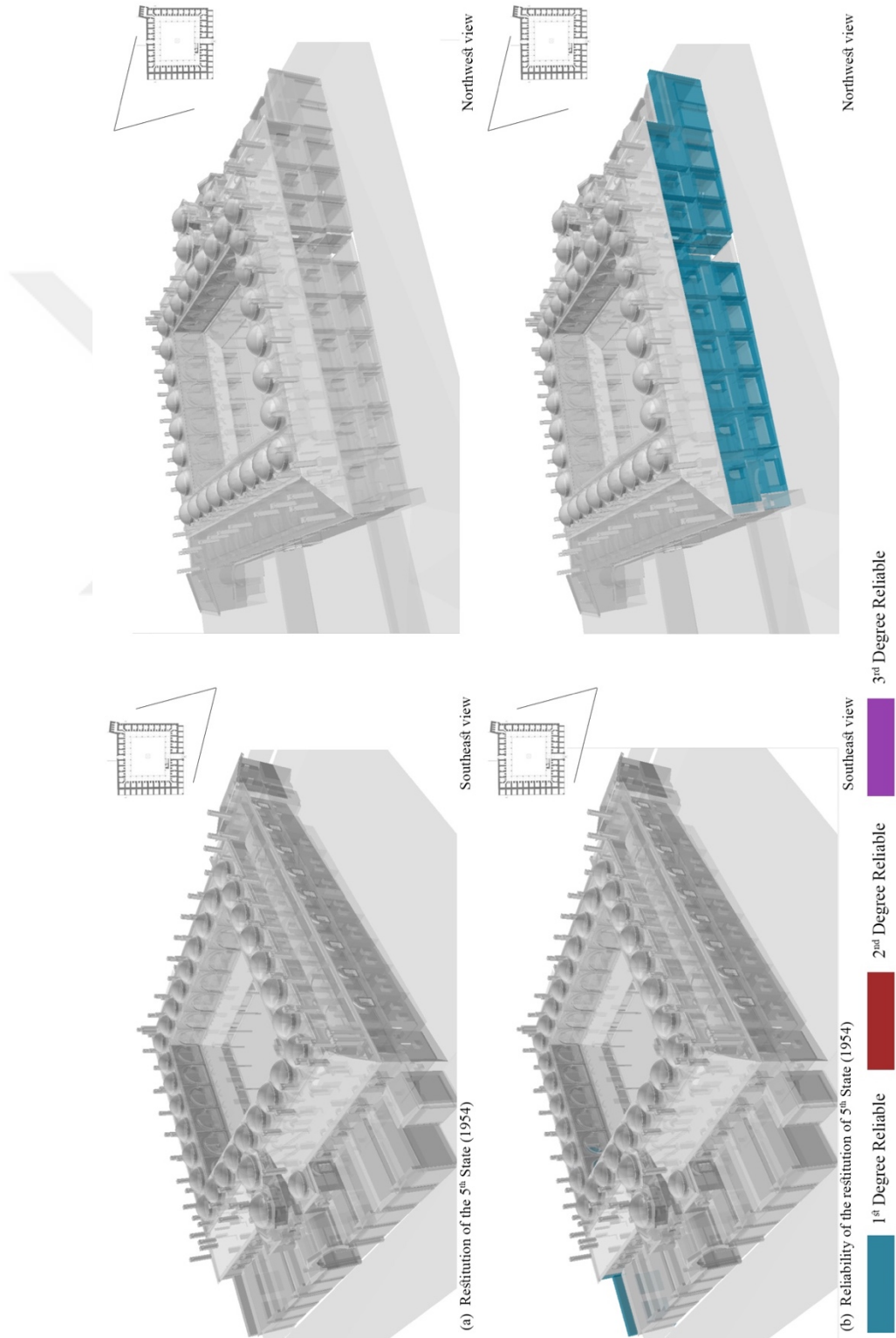

# APPENDIX F

## VISUALIZATION OF THE 6<sup>th</sup> STATE (1966-1970) IN ARCSCENE MODULE OF ARCGIS

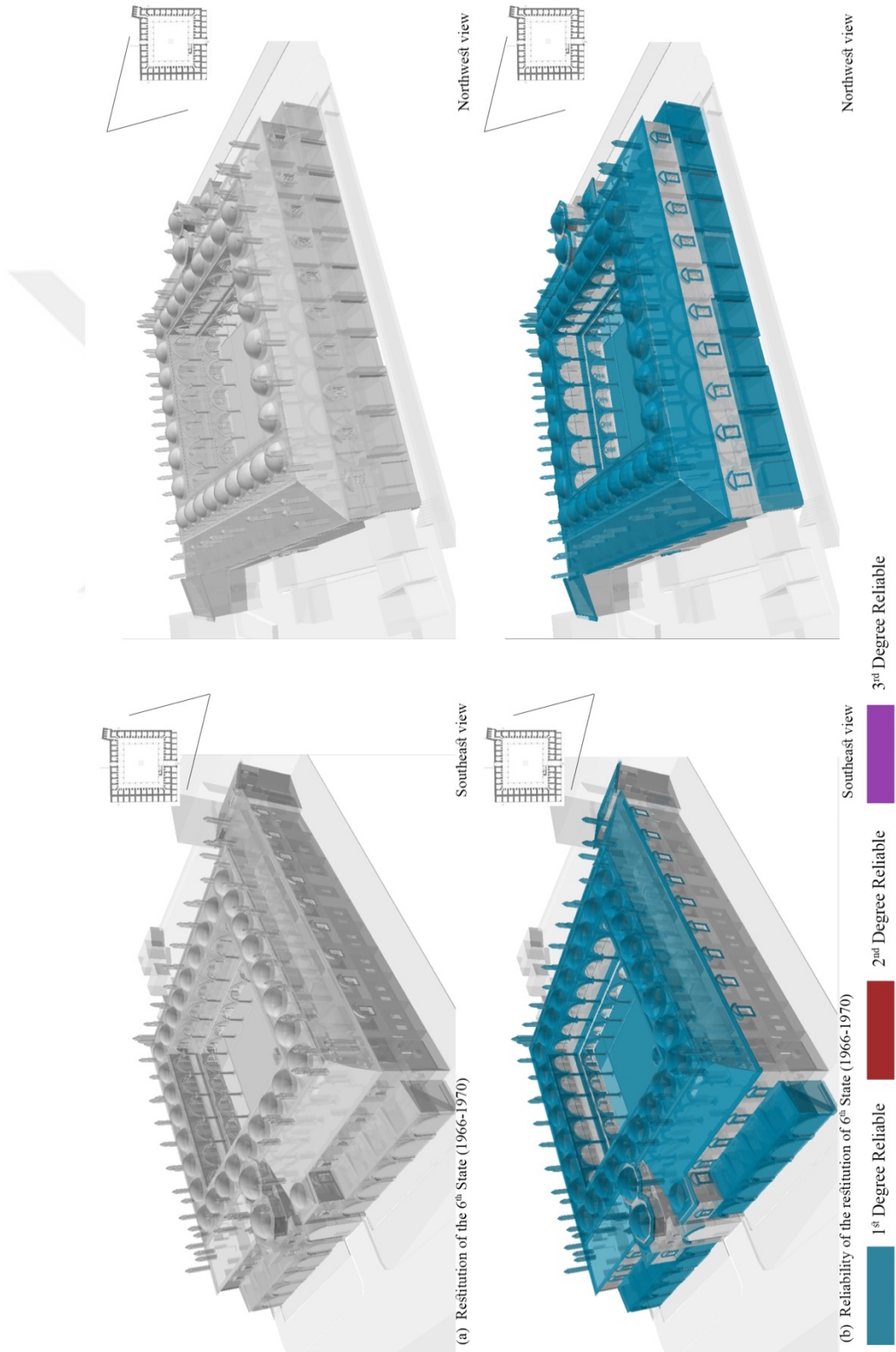

# APPENDIX G

## VISUALIZATION OF THE AS-FOUND STATE (2011) IN ARCSCENE MODULE OF ARCGIS

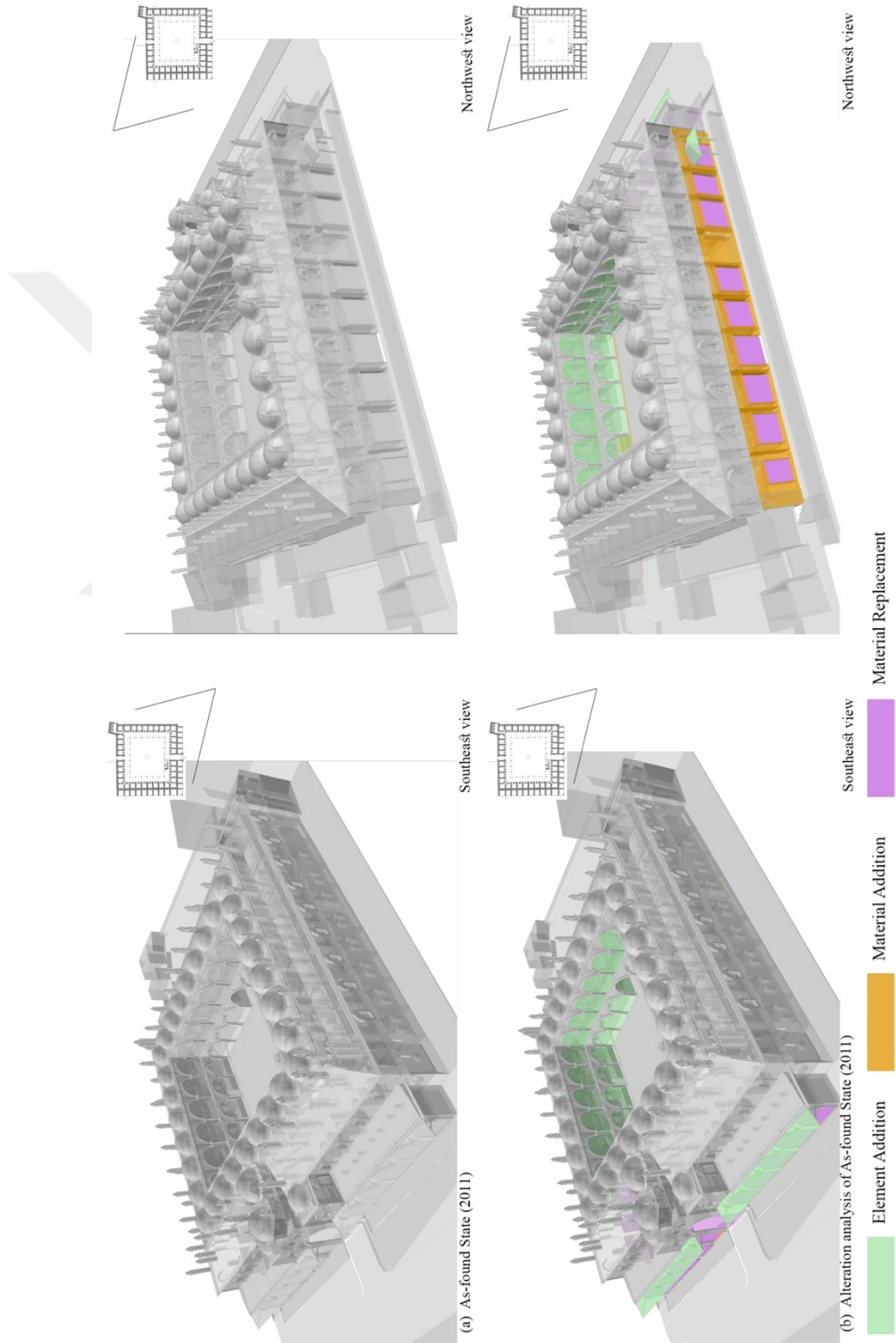

# APPENDIX H

## BUILDING QUERY IN ARCSCE (3<sup>rd</sup> STATE) E.G. 2<sup>ND</sup> DEGREE RELIABLE STRUCTURAL ELEMENTS

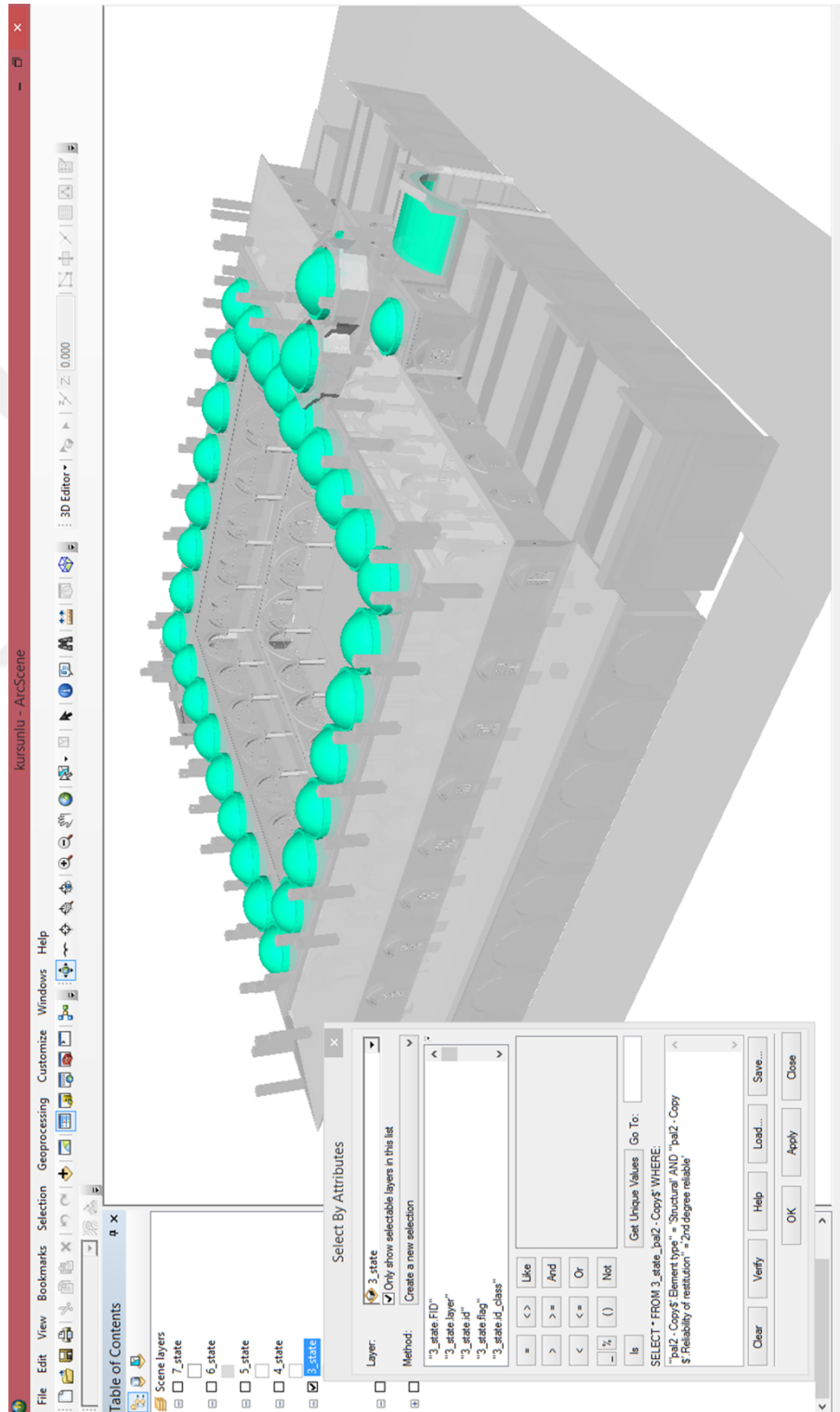



# APPENDIX J

## BUILDING QUERY IN ARCSCE (6<sup>th</sup> STATE) E.G. 1<sup>ST</sup> DEGREE RELIABLE STRUCTURAL ELEMENTS MADE OF CONCRETE

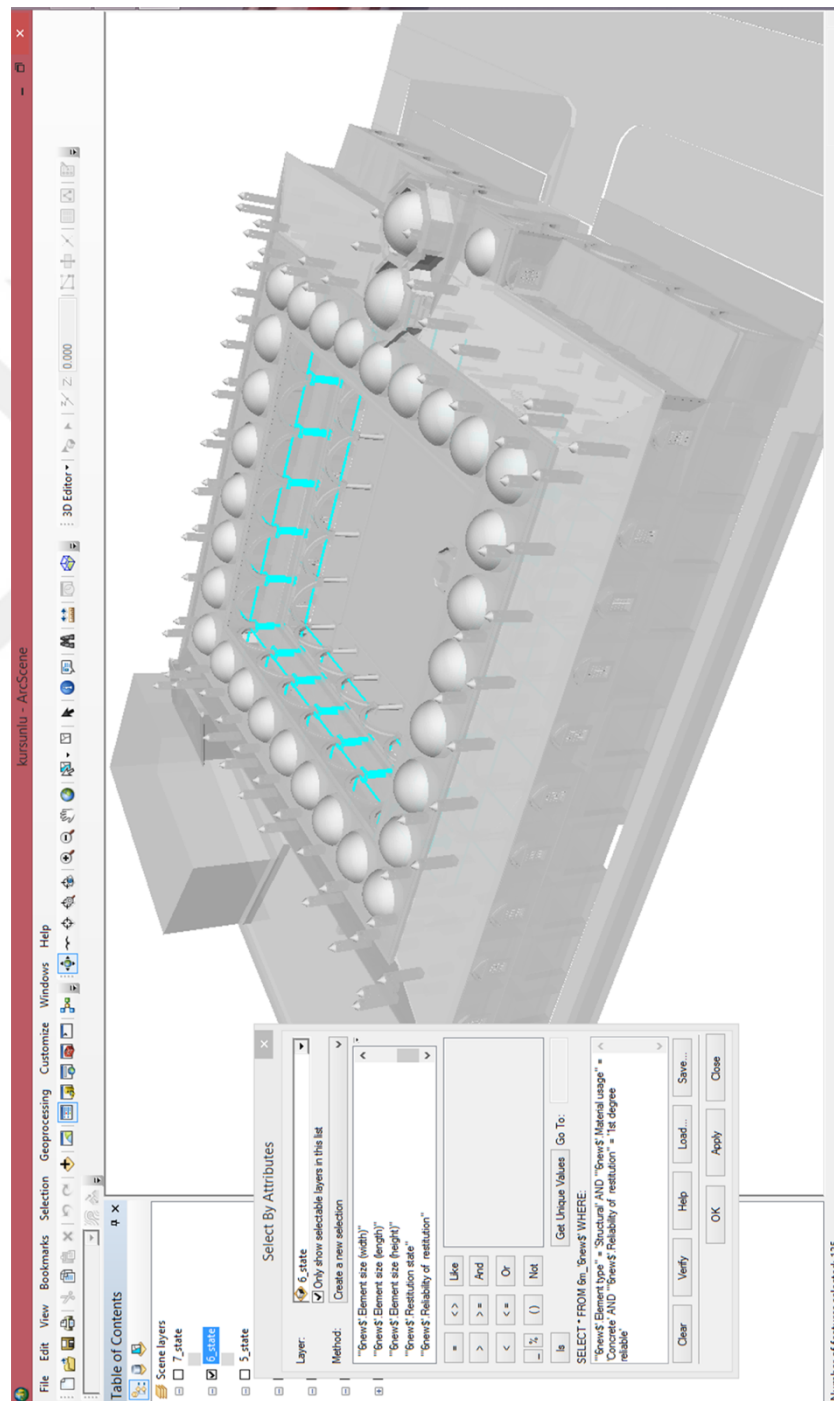

# APPENDIX K

## BUILDING QUERY IN ARCSCE (AS-FOUND STATE) E.G. ELEMENT ADDITIONS

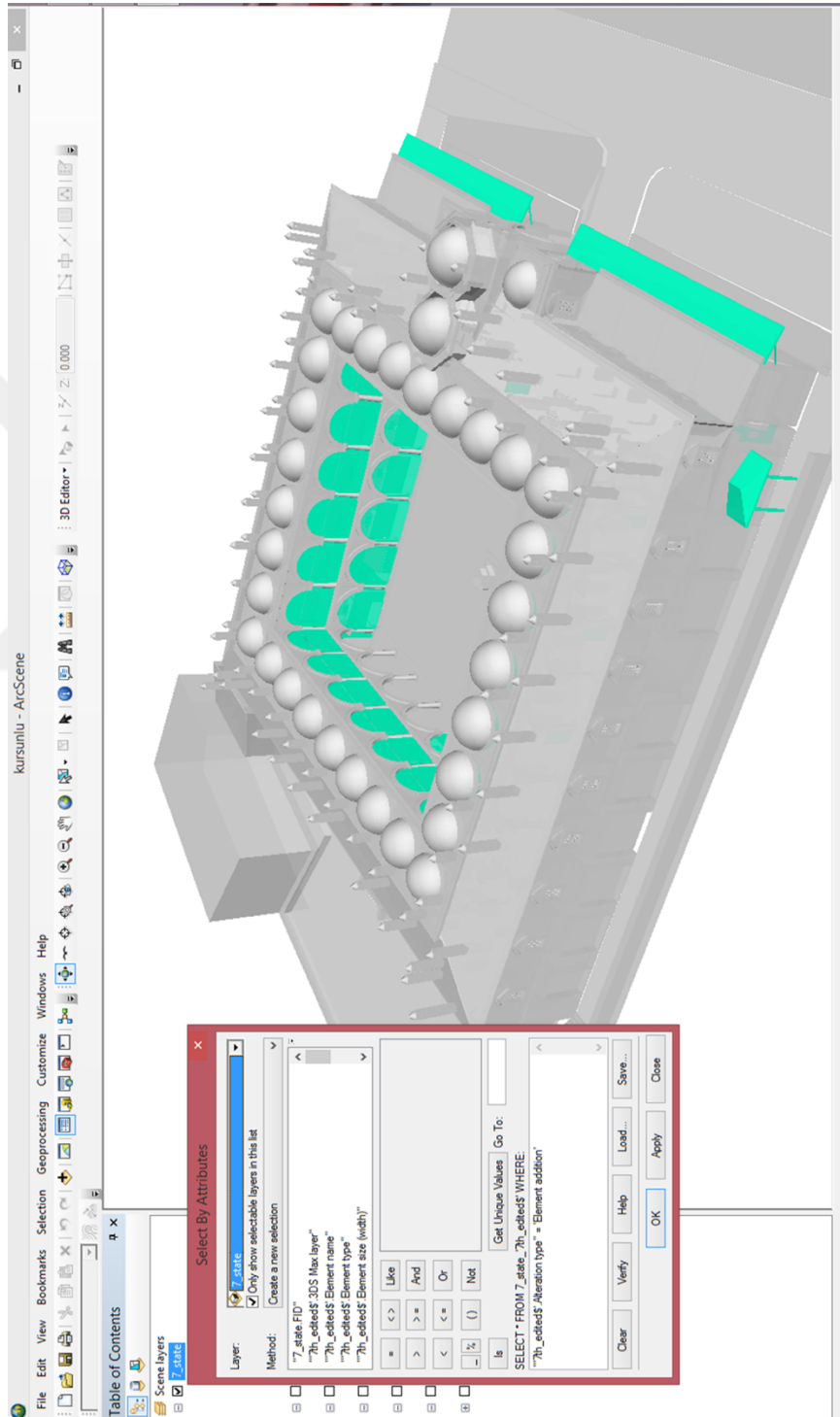

# APPENDIX L

## DATA VISUALAZITION IN ARCSCE (5<sup>th</sup> STATE) E.G. PHOTOGRAPH OF NORTHERN FAÇADE AS SOURCES OF RESTITUTION

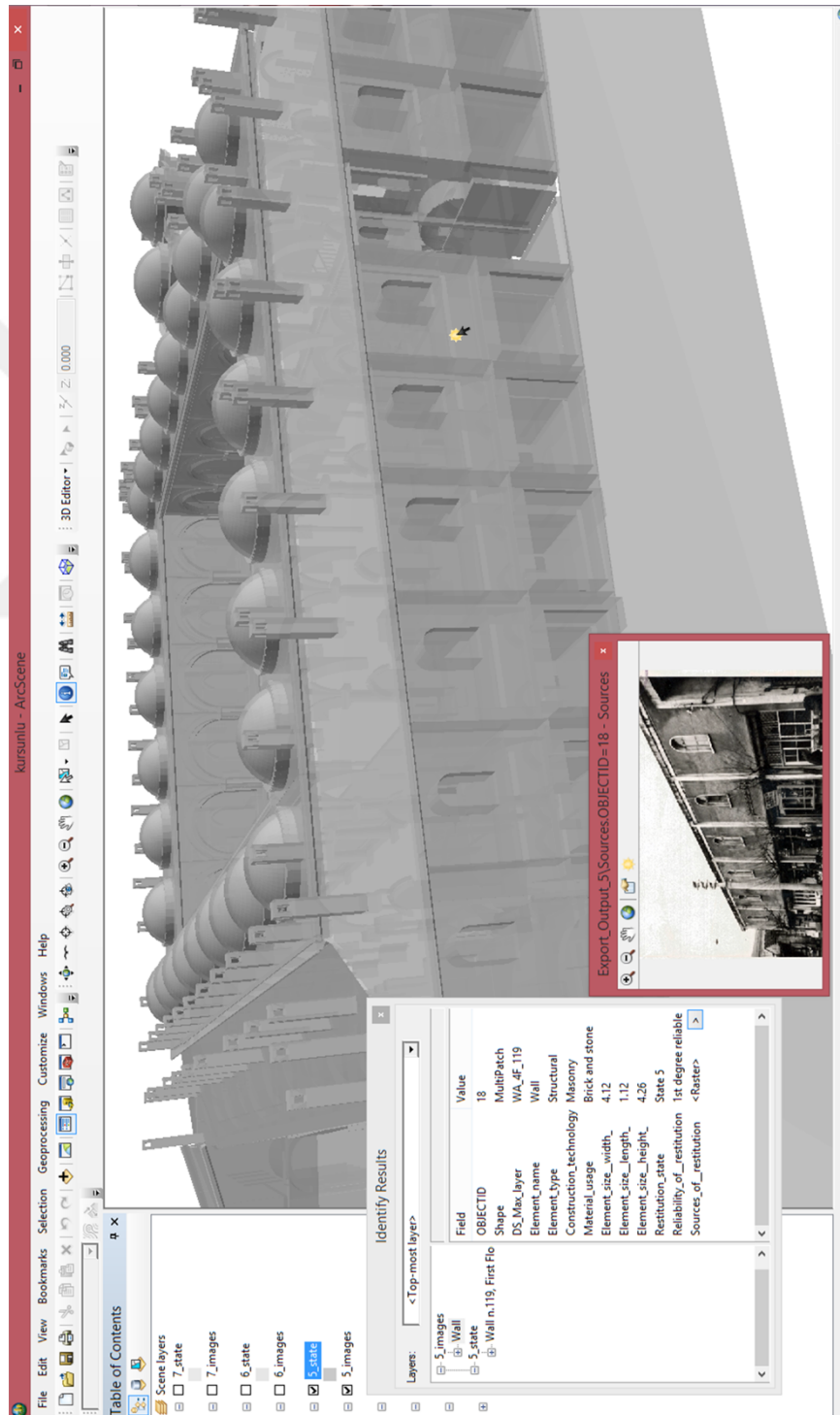

# APPENDIX M

## DATA VISUALAZITION IN ARCSCENE 6<sup>th</sup> STATE E.G. PHOTOGRAPH OF COLLONADED PORTICO AS SOURCES OF RESTITUTION

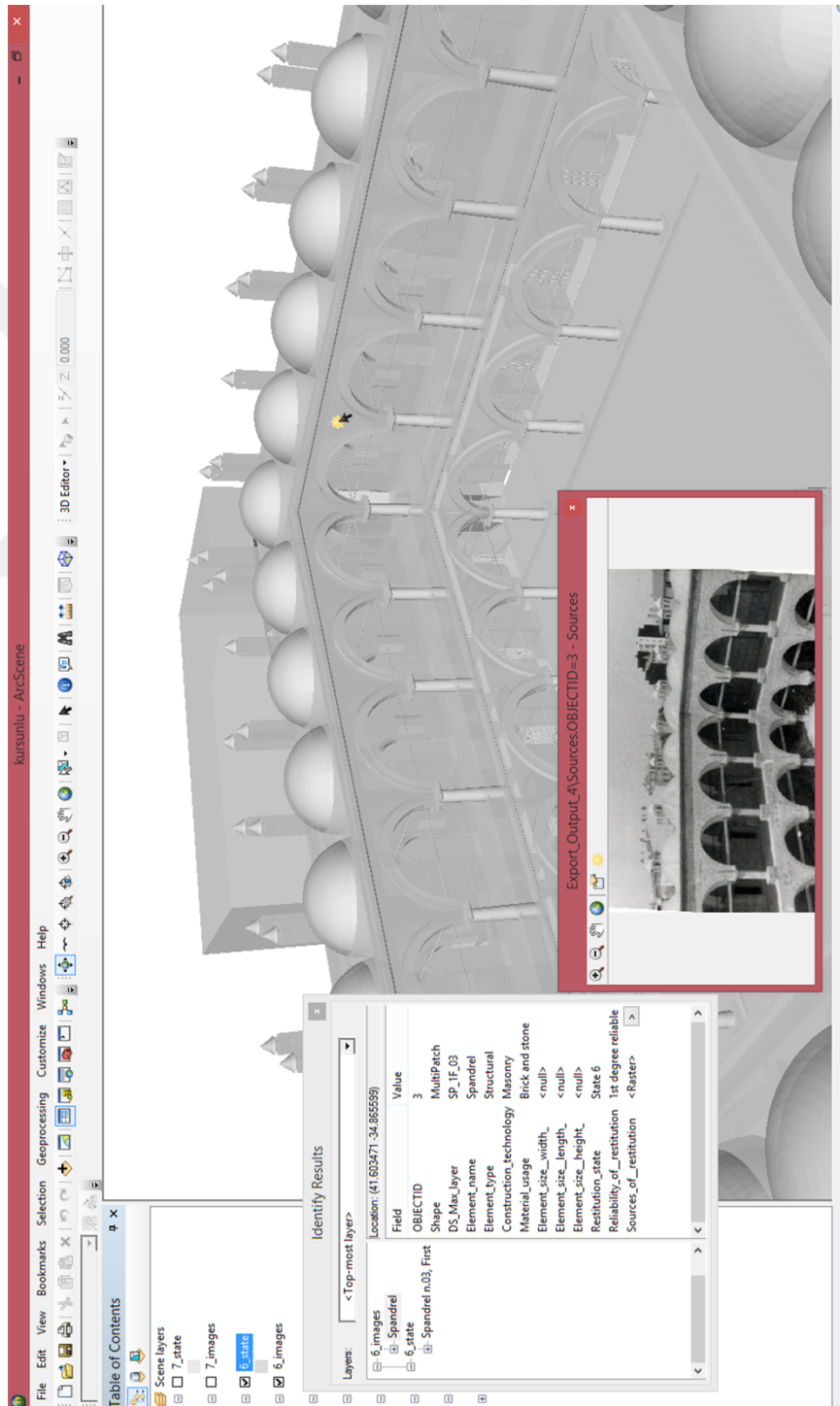

# APPENDIX N

## DATA VISUALAZITION IN ARCSCE (AS-FOUND STATE) E.G. PHOTOGRAPH OF COLLONADED PORTICO AS SOURCES OF RESTITUTION

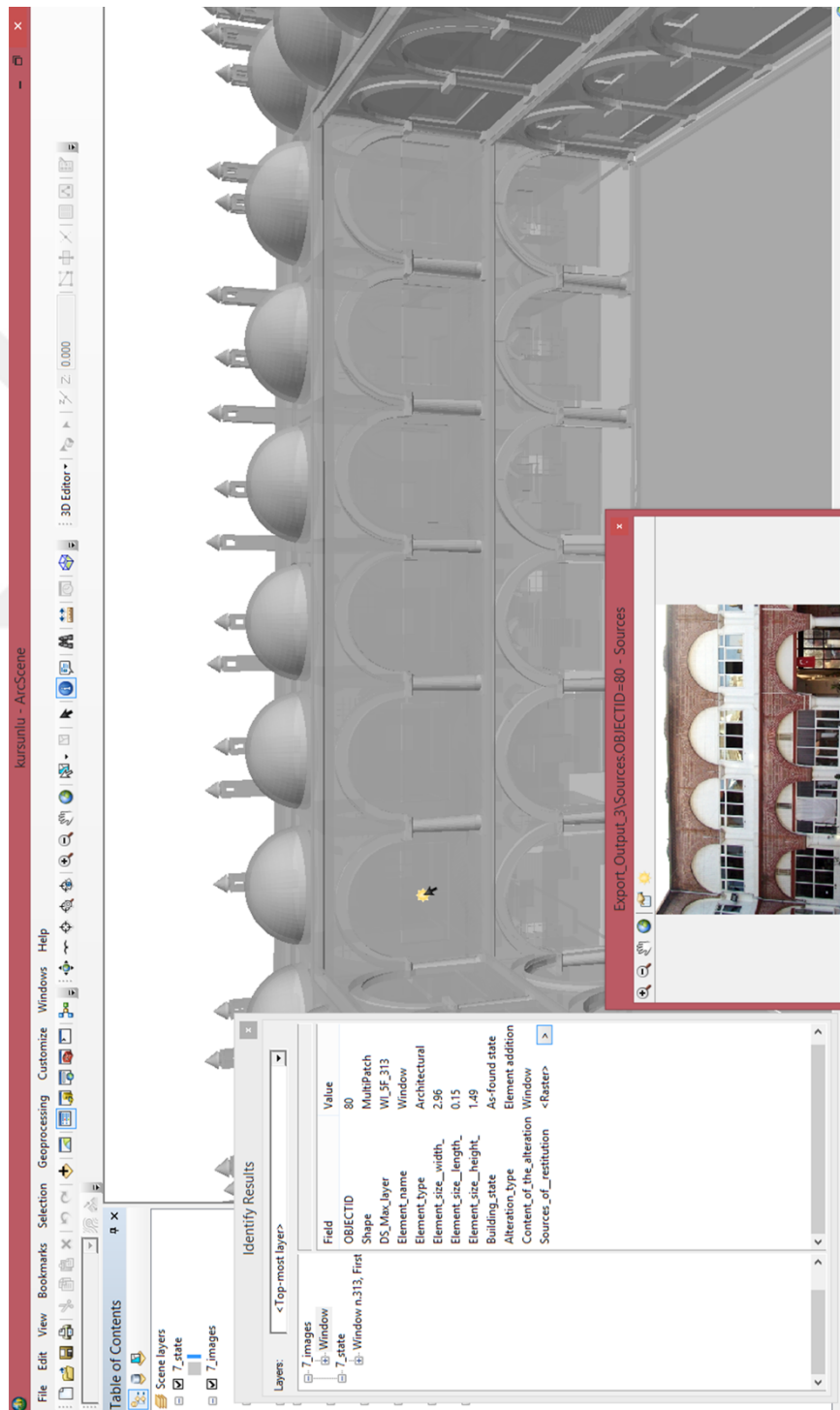

# APPENDIX P

## DATA VISUALIZATION IN GUI (RESTITUTION STATES)

The screenshot displays a web application interface. The top section, titled 'Temporal phases', contains a table with columns for 'Actions', 'Class', 'Name', and 'Function'. The table lists seven states from the 2nd to the 7th. The '4th State (1908)' is selected, and its details are shown in a 'View' panel below. This panel includes a '3D model' download button and a 'Notes' section with detailed text about the state's history and restoration.

| Actions | Class    | Name                  | Function                                   |
|---------|----------|-----------------------|--|
|         | Building | 2nd State (1843)      | Osmanlı şehirci han mercantile, accommodat |
|         | Building | 3rd State (1848)      | Osmanlı şehirci han mercantile, accommodat |
|         | Building | 4th State (1908)      | Prison.                                    |
|         | Building | 5th State (1954)      | Mercantile, accommodat                     |
|         | Building | 6th State (1966-1970) | Mercantile, accommodat                     |
|         | Building | As-found State (2011) | Student dormitory.                         |
|         | Building | Original State (1488) | Osmanlı şehirci han mercantile, accommodat |

| Class            | Building  |
|------------------|---|
| Name             | 4th State (1908)  |
| Function         | Prison.   |
| Cadastral Info   | NULL  |
| Length [m]       | 52.000  |
| Height [m]       | 12.000  |
| Width [m]        | 51.000  |
| Vol. Composition | Square plan, inner courtyard  |
| Floors           | 2   |
| Num. faces       | 389468  |
| Notes            | The refuinction of the khan as a prison dates back to 1908/1325. It is stated that Kurşunlu Khan, which was the property of the municipality and located very close to the carsı, was rented in order to cover spatial insufficiency of Manisa Prison for the actual number of the condemned people and due to the contagious diseases around them (The Ottoman Archive Catalogues 2015). As a result of the change in the function, some major interventions were done. The colonnaded portico was converted into closed-spaces, i.e. rooms. Those converted spaces were connected to the courtyard by rectangular windows and doors, one for each. A new semi-open space was created juxtaposing those rooms with a simple wooden construction. |

# APPENDIX R

## DATA VISUALIZATION IN GUI (SPACES PER PHASE)

Temporal phases External Data gamze

### Spaces per Phase

Master record (return to list)

| Class    | Name                  | Function   | Cadastral Info | Length [m] | Height [m] | Width [m] | Vol. Composition             | Floors | Num. faces | Notes   | 3D model |
|----------|-----------------------|--|----------------|------------|------------|-----------|------------------------------|--------|------------|---|----------|
| Building | Original State (1498) | Osmanlı şehirciği hanı, mercantile, accommodation. | NULL           | 48.000     | 12.000     | 51.000    | Square plan, inner courtyard | 2      | 396540     | Square courtyard surrounded by colonnaded porticoes and rooms on two floors. In the original state,... more | download |

Spaces per Phase Images per Phase

« 1 2 ... 6 »

+ ↻ ↺ ↻ ↺ ↻ ↺

↑ ↓ ⚙

| Actions         | ID  | Type          | Name                            | Level | Description  | Enclosure quality |
|-----------------|-----|---------------|---------------------------------|-------|--------------|-------------------|
| ☐ + ↻ ↺ ↻ ↺ ↻ ↺ | 97  | Courtyard     | Space n.062, Ground Floor, Ph.1 | 0     | central type | Open              |
| ☐ + ↻ ↺ ↻ ↺ ↻ ↺ | 49  | Entrance Hall | Space n.014, Ground Floor, Ph.1 | 0     | NULL         | Closed            |
| ☐ + ↻ ↺ ↻ ↺ ↻ ↺ | 69  | Entrance Hall | Space n.034, Ground Floor, Ph.1 | 0     | NULL         | Closed            |
| ☐ + ↻ ↺ ↻ ↺ ↻ ↺ | 98  | Portico       | Space n.063, Ground Floor, Ph.1 | 0     | NULL         | Semi-open         |
| ☐ + ↻ ↺ ↻ ↺ ↻ ↺ | 99  | Portico       | Space n.064, Ground Floor, Ph.1 | 0     | NULL         | Semi-open         |
| ☐ + ↻ ↺ ↻ ↺ ↻ ↺ | 101 | Portico       | Space n.066, Ground Floor, Ph.1 | 0     | NULL         | Semi-open         |
| ☐ + ↻ ↺ ↻ ↺ ↻ ↺ | 144 | Portico       | Space n.143, First Floor, Ph.1  | 1     | NULL         | Semi-open         |
| ☐ + ↻ ↺ ↻ ↺ ↻ ↺ | 146 | Portico       | Space n.145, First Floor, Ph.1  | 1     | NULL         | Semi-open         |
| ☐ + ↻ ↺ ↻ ↺ ↻ ↺ | 143 | Portico       | Space n.142, First Floor, Ph.1  | 1     | NULL         | Semi-open         |
| ☐ + ↻ ↺ ↻ ↺ ↻ ↺ | 100 | Portico       | Space n.065, Ground Floor, Ph.1 | 0     | NULL         | Semi-open         |
| ☐ + ↻ ↺ ↻ ↺ ↻ ↺ | 145 | Portico       | Space n.144, First Floor, Ph.1  | 1     | NULL         | Semi-open         |
| ☐ + ↻ ↺ ↻ ↺ ↻ ↺ | 1   | Room          | Space n.001, Ground Floor, Ph.1 | 0     | NULL         | Closed            |
| ☐ + ↻ ↺ ↻ ↺ ↻ ↺ | 46  | Room          | Space n.011, Ground Floor, Ph.1 | 0     | NULL         | Closed            |
| ☐ + ↻ ↺ ↻ ↺ ↻ ↺ | 47  | Room          | Space n.012, Ground Floor, Ph.1 | 0     | NULL         | Closed            |
| ☐ + ↻ ↺ ↻ ↺ ↻ ↺ | 43  | Room          | Space n.008, Ground Floor, Ph.1 | 0     | NULL         | Closed            |
| ☐ + ↻ ↺ ↻ ↺ ↻ ↺ | 52  | Room          | Space n.017, Ground Floor, Ph.1 | 0     | NULL         | Closed            |
| ☐ + ↻ ↺ ↻ ↺ ↻ ↺ | 44  | Room          | Space n.009, Ground Floor, Ph.1 | 0     | NULL         | Closed            |
| ☐ + ↻ ↺ ↻ ↺ ↻ ↺ | 5   | Room          | Space n.005, Ground Floor, Ph.1 | 0     | NULL         | Closed            |
| ☐ + ↻ ↺ ↻ ↺ ↻ ↺ | 4   | Room          | Space n.004, Ground Floor, Ph.1 | 0     | NULL         | Closed            |

« 1 2 ... 6 »

# APPENDIX S

## DATA VISUALIZATION IN GUI (BUILDING ELEMENTS PER SPACE)

The screenshot shows a web browser window with the URL `sbc1.ait.ac.at`. The page title is "Building elements per Space". At the top, there are navigation links for "Temporal phases" and "External Data", and a user profile for "gamze". Below the title, there is a "Master record (return to list)" section with a table containing one row:

| ID | Type | Name                            | Level | Description | Enclosure quality |
|----|------|---------------------------------|-------|-------------|-------------------|
| 1  | Room | Space n.001, Ground Floor, Ph.1 | 0     | NULL        | Closed            |

Below this table are navigation controls: a page indicator showing "1" and a set of action icons (add, edit, delete, refresh, print, export, import, settings).

The main part of the page is a table listing building elements:

| <input type="checkbox"/> | Actions | ID   | Class                | Name ↓                                 | Relation ID |
|--------------------------|---------|------|----------------------|--|-------------|
| <input type="checkbox"/> |         | 1067 | BarrelVault          | Barrel vault n.04, Ground Floor        | 997         |
| <input type="checkbox"/> |         | 265  | Door                 | Door n.04, Ground Floor                | 509         |
| <input type="checkbox"/> |         | 476  | Niche                | Niche n.01, Ground Floor               | 364         |
| <input type="checkbox"/> |         | 676  | OtherBuildingElement | Other arch. element n.49, Ground Floor | 761         |
| <input type="checkbox"/> |         | 695  | OtherBuildingElement | Other arch. element n.68, Ground Floor | 760         |
| <input type="checkbox"/> |         | 745  | OtherBuildingElement | Railing n.09, Ground Floor             | 632         |
| <input type="checkbox"/> |         | 840  | Slab                 | Slab n.09, Ground Floor                | 434         |
| <input type="checkbox"/> |         | 1311 | Wall                 | Wall n.13, Ground Floor                | 54          |
| <input type="checkbox"/> |         | 1348 | Wall                 | Wall n.163, Ground Floor               | 56          |
| <input type="checkbox"/> |         | 1358 | Wall                 | Wall n.22, Ground Floor                | 55          |
| <input type="checkbox"/> |         | 1360 | Wall                 | Wall n.24, Ground Floor                | 53          |
| <input type="checkbox"/> |         | 1480 | Window               | Window n.01, Ground Floor              | 614         |

At the bottom, there is another page indicator showing "1".



## APPENDIX T

### DATA VISUALIZATION (IMAGES PER PHASE)

Temporal phases Spaces Images Classes Geometries Building elements External Data Relations gamze

sbc1.ait.ac.at

sbci ait ac at

## Images per Phase

Master record [\(return to list\)](#)

| Class    | Name                  | Function                   | Cadastral Info            | Length [m] | Height [m] | Width [m] | Vol. Composition             | Floors | Num. faces | Notes   | 3D model |
|----------|-----------------------|----------------------------|---------------------------|------------|------------|-----------|------------------------------|--------|------------|---|----------|
| Building | 6th State (1966-1970) | Mercantile, accommodation. | 47pafta, 360ada, 19parsel | 48.000     | 12.000     | 47.000    | Square plan, inner courtyard | 2      | 405230     | In 1966, the General Directorate of Pious Foundations started a restoration campaign for Kurşunlu Kh... <a href="#">more</a> <a href="#">download</a> |          |

Spaces per Phase Images per Phase

Quick search

| Actions | ID | Name  | Description | Notes                           | Image |
|---------|----|---|-------------|---------------------------------|-------|
|         | 48 | Northern colonnaded portico after restoration works.  | NULL        | Source: Archives of ARK İnşaat. |       |
|         | 49 | Northwest view of the colonnaded portico during restoration works.                                    | NULL        | Source: Archives of ARK İnşaat  |       |
|         | 50 | Southeast view of the colonnaded portico during restoration works.                                    | NULL        | Source: Archives of ARK İnşaat  |       |
|         | 51 | Northeast view of the colonnaded portico after restoration works of 1966-1970... <a href="#">more</a> | NULL        | Source: Archives of ARK İnşaat  |       |
|         | 52 | Staircase   | NULL        | Source: Archives of ARK İnşaat  |       |
|         | 55 | Colonnaded portico (interior section) during restoration works of 1966-1970... <a href="#">more</a>   | NULL        | Source: Archives of ARK İnşaat  |       |
|         | 59 | Colonnaded portico (interior section) after restoration works   | NULL        | Source: Archives of ARK İnşaat  |       |
|         | 60 | Partial west view of the building   | NULL        | Source: Archives of ARK İnşaat  |       |

# APPENDIX U

## DATA VISUALIZATION IN GUI (EXTERNAL DATA)

The screenshot displays a web application interface for 'External Data'. The page title is 'External Data' and the URL is 'sbc1.ait.ac.at'. The interface includes a navigation bar with 'Temporal phases' and 'External Data' options, and a user profile 'gamze'. The main content area features a table with columns for 'Actions', 'ID', 'Description', 'Notes', 'File Name', 'File Extension', 'File Size', and 'File'. The table contains 12 rows of data, each representing a historical document or report with its corresponding file information and a download link.

| Actions                  | ID | Description  | Notes   | File Name                             | File Extension | File Size | File                     |
|--------------------------|----|--|---|---------------------------------------|----------------|-----------|--------------------------|
| <input type="checkbox"/> | 33 | The oldest document belonging to Kurşunlu Khan is the charter of the pious foundation ("Manisa Hasna şaz Hatun binti Abdülceill Vakfı") in Arabic dat... | (1998) Source: Art historian Tekin Süllü's report, Archives of ARK İnşaat.                              | sanat_tarih_raporu_903tarihli.pdf     | pdf            | 215140    | <a href="#">download</a> |
| <input type="checkbox"/> | 32 | Historic document (and its translation) regarding to the 3rd State (1848) Specific to the repairs of 1843/1259.  | (1843) Source: Art historian Tekin Süllü's report, Archives of ARK İnşaat.                              | sanat_tarih_raporu_1259tarihli.pdf    | pdf            | 144535    | <a href="#">download</a> |
| <input type="checkbox"/> | 31 | Historic document (and its translation) regarding to the 3rd State (1848)  | (1848) Source: Art historian Tekin Süllü's report, Archives of ARK İnşaat.                              | sanat_tarih_raporu_1264tarihli.pdf    | pdf            | 123786    | <a href="#">download</a> |
| <input type="checkbox"/> | 30 | Historic document (and its translation) regarding to the 4th State (1908)  | (1908) Source: Art historian Tekin Süllü's report, Archives of ARK İnşaat.                              | sanat_tarih_raporu_1325tarihli.pdf    | pdf            | 136243    | <a href="#">download</a> |
| <input type="checkbox"/> | 13 | Filliz Oğuz's article (1974) entitled "Manisa Kurşunlu Han," regarding to the 6th State.   | (1974) Rölöve ve Restorasyon Dergisi, p.109.  | SKMBT_C25007011606561.jpg             | jpg            | 331126    | <a href="#">download</a> |
| <input type="checkbox"/> | 34 | Filliz Oğuz's article (1974) entitled "Manisa Kurşunlu Han," regarding to the 6th State.   | (1974) Rölöve ve Restorasyon Dergisi, p.110.  | SKMBT_C25007011606562.jpg             | jpg            | 755598    | <a href="#">download</a> |
| <input type="checkbox"/> | 35 | Filliz Oğuz's article (1974) entitled "Manisa Kurşunlu Han," regarding to the 6th State.   | (1974) Rölöve ve Restorasyon Dergisi, p.111.  | SKMBT_C25007011606563.jpg             | jpg            | 757648    | <a href="#">download</a> |
| <input type="checkbox"/> | 5  | Decision number 7009 of the Izmir Number 2 Regional Conservation Council of Cultural and Natural Wealth on May 27, 2011.                                 | (2011) Source: Archives of ARK İnşaat.  | 1 kurş.kur.KARAR 04.07.2011 13-05.pdf | pdf            | 288306    | <a href="#">download</a> |
| <input type="checkbox"/> | 21 | Statistical investigation and evaluation by Civil Eng. All Tosun.  | (2011) Source: Archives of ARK İnşaat.  | statik_rapor.doc                      | doc            | 95232     | <a href="#">download</a> |
| <input type="checkbox"/> | 36 | Key plan for space labelling.  | (2013) It is used for an understanding of "building elements per space", and "spaces per phase" tables. | key_plan_for_space_labelling.jpg      | jpg            | 589449    | <a href="#">download</a> |

# APPENDIX V

## DATA VISUALIZATION IN GUI (EXTERNAL DATA) E.G. ART HISTORY REPORT

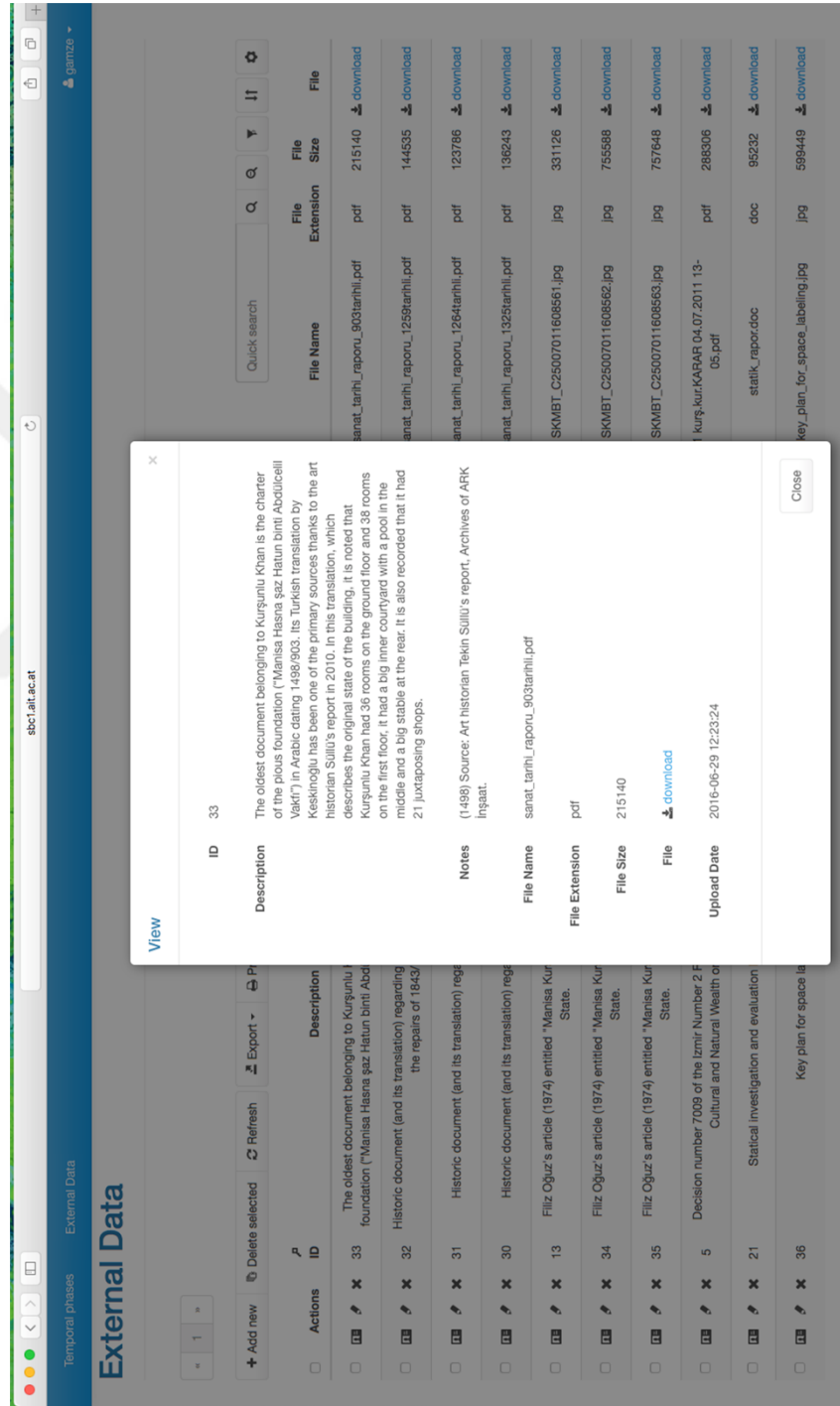

# APPENDIX Y

## TABULAR DATA EXTRACTION

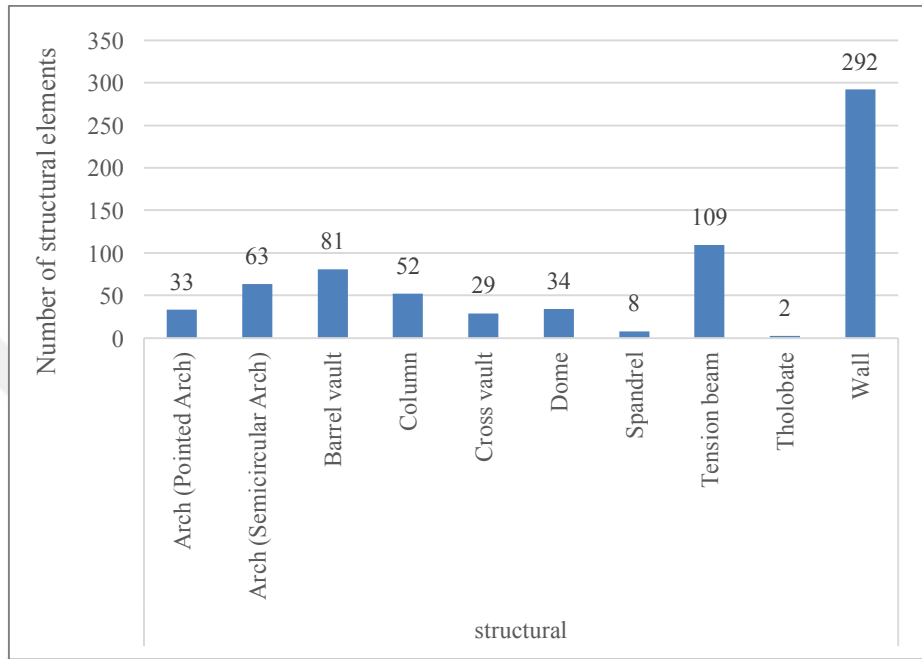

Number of structural elements used in the Original State (1498).

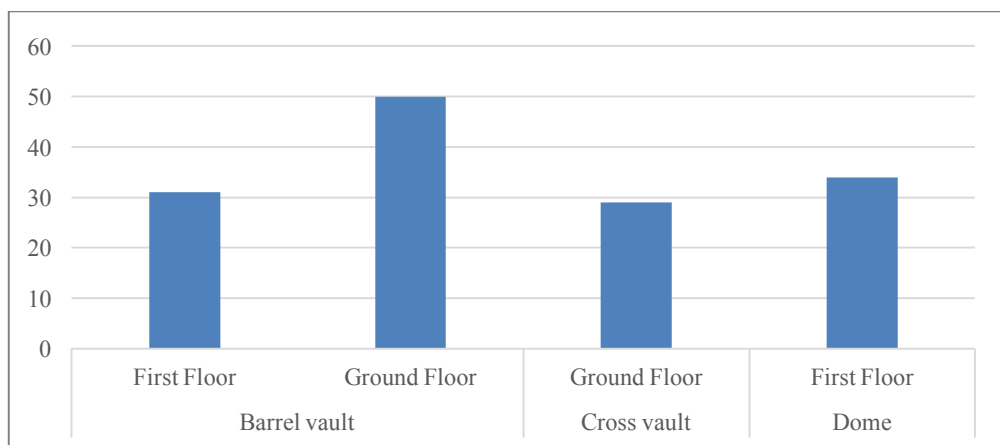

Number of elements spanning spaces and their distribution on floors of the Original State (1498).

# VITA

## GAMZE SAYGI

Gamze Saygı was born (in 1983) and raised in İzmir, Turkey. Following her high school education, she attended Dokuz Eylül University (DEÜ) where she earned a Bachelor of Architecture in 2006. Following that, from 2006 to 2009, she attended Izmir Institute of Technology (IYTE), and received a Master of Science degree in Architectural Restoration. She started her PhD in Architecture in 2010 at the same university. During her PhD studies, she awarded a research scholarship from the Council of Higher Education of Turkey (YÖK) for one-year, and was a visiting-scholar in 3D Optical Metrology (3DOM) Research Unit of Bruno Kessler Foundation (FBK) in Trento, Italy. Her research interests include preservation of historic buildings, recording and management strategies for cultural heritage. In particular, she is interested in the utilization of digital data acquisition technologies (3D laser scanning, digital photogrammetry) for documentation, and information management technologies for cultural heritage.

Her professional experience in academics, as a research assistant, started at Yaşar University, Izmir in January 2008 where she also involved as a teaching assistant in undergraduate courses: Basic Design, Architectural Design and Architectural Conservation studios. From September 2011 onwards, she continues holding a Research Assistant position in the Department of Architecture (Restoration Discipline) at Dokuz Eylül University in İzmir, Turkey, where she may be reached.