

USER FRIENDLY TAXIS
MODIFYING AND DEVELOPING THE DESIGN OF
CURRENTLY USED TAXIS

By

Korkut Mutaf

January 2009

USER FRIENDLY TAXIS
MODIFYING AND DEVELOPING THE DESIGN OF
CURRENTLY USED TAXIS

A THESIS SUBMITTED TO
THE GRADUATE SCHOOL OF SOCIAL SCIENCES
OF
IZMIR UNIVERSITY OF ECONOMICS

By

Korkut Mutaf

IN PARTIAL FULFILLMENT OF THE REQUIREMENTS FOR THE DEGREE OF
MASTER OF ART
IN
THE GRADUATE SCHOOL OF SOCIAL SCIENCES

January 2009

Approval of the Graduate School of Social Sciences

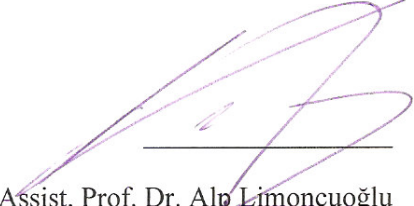
Assist. Prof. Dr. Alp Limoncuoğlu

Director

I certify that this thesis satisfies all the requirements as a thesis for the degree of Master of Art.

Prof. Dr. Tevfik Balcioglu

Head of Department

This is to certify that we have read this thesis and that in our opinion it is fully adequate, in scope and quality, as a thesis for the degree of Master of Art.

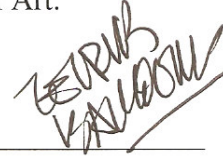
Prof. Dr. Tevfik Balcioglu

Supervisor



Examining Committee Members

(Title and Name in alphabetical order of last name)

Prof. Dr. Tevfik Balcioglu

Assoc. Prof. Dr. Murat Günaydin

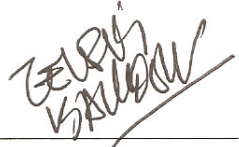
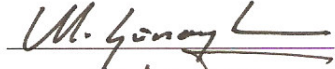
Assist. Prof. Dr. A.Can Özcan

ABSTRACT

USER FRIENDLY TAXIS

MODIFYING AND DEVELOPING THE DESIGN OF CURRENTLY USED TAXIS

Mutaf, Korkut

MA, Department of Design Studies

Supervisor: Prof. Dr. Tefvik Balciođlu

January 2009, 104 pages

This project will try to figure out economical solutions for the owners of the current taxi vehicles and the users of the taxi system in order to bring higher standards to provide more comfortable and safer journey. Current vehicles are not satisfactory in terms of providing adequate comfort and safety because their design is not suitable for usage as a taxi. This thesis highlights these differences in order to create a more sufficient approach to the taxi design. Besides trying to increase the comfort, safety and functionality of the taxis, this study also concentrates on the ease of the reuse of the mechanical parts of the existing taxis which will provide additional economic gains for owners or drivers of the vehicles. Furthermore, less repair time and less repair cost will be beneficial for the owners and the drivers; and also, standardization of all the vehicles will bring a more civilized and modern appearance to the cities.

Key Words: Taxi, Cab, Vehicle Design, Transportation

ÖZET

KULLANICI DOSTU TAKSİLER

KULLANILMAKTA OLAN TAKSİLERİN TASARIMININ MODİFİYE EDİLMESİ VE GELİŞTİRİLMESİ

Mutaf, Korkut

Yüksek Lisans, Tasarım Çalışmaları Bölümü

Tez Yöneticisi: Prof. Dr. Tevfik Balcıoğlu

Ocak 2009, 104 sayfa

Bu proje, mevcut taksi sürücülerine, araçlarını daha rahat ve daha güvenli yolculuk yapılabilecek yüksek standartlara ulaştırabilmeleri için ekonomik çözüm önerileri sunmayı amaçlamaktadır. Mevcut araçlar, taksi olarak kullanılmak amacıyla tasarlanmadıkları için, konfor ve güvenlik sağlama açısından yetersiz kalmaktadır. Bu araştırma, taksilerin diğer araçlarla olan farklılıklarının altını çizerek, taksilerin tasarımlarının daha nitelikli hale getirilmesi gerektiğini vurgulamaktadır. Bu araştırmada sunulan öneriler taksilerin konforunu, güvenliğini ve işlevini arttırmanın yanı sıra, mevcut araçların mekanik parçalarının kullanımına devam edilerek sürücülere ve araç sahiplerine ekonomik anlamda da artılar kazandırmayı hedeflemektedir. Daha kısa ve daha az masraflı tamir süreci, taksi sahipleri ve sürücüleri için daha karlı olurken, diğer yandan da bütün taksilerin standart hale gelmesi şehre daha modern ve uygar bir görünüm kazandıracaktır.

Anahtar Kelimeler: Taksi, Araç tasarımı, Ulaşım

ACKNOWLEDGMENTS

I would like to express my gratitude to my supervisor, Prof. Dr. Tevfik Balciođlu, whose expertise, understanding, and patience, added considerably to my graduate experience. I am grateful to Assist. Prof. Dr. Can Özcan for the recommendations he provided at all levels of the research project. I would like to gratefully thank Assoc. Prof. Dr. Murat Günaydın for his valuable interpretations in the critics of the final jury.

I would also like to thank my family for the support they provided me through my entire life and in particular, without whose love, encouragement and editing assistance, I would not have finished this thesis.

TABLE OF CONTENTS

ABSTRACT	iii
ÖZET	iv
ACKNOWLEDGMENTS	v
TABLE OF CONTENTS	vi
LIST OF FIGURES.....	ix
CHAPTER	
1.INTRODUCTION	1
2.HISTORY OF THE TAXI	3
2.1- The History of the Yellow Cab (America)	4
2.2- The History of the London Cab (Europe).....	8
3.PROBLEMS OF CURRENTLY USED TAXIS	13
3.1- Ordinary Family Sedan Cars Being Used as Taxis	13
3.2- Design Insufficiency of the Current Taxis	14
3.3- Required Design Criteria	15
3.3.1- Driver View Point.....	16
3.3.2- Ergonomics as a Fundamental Aspect of Automobile Design.	18
3.3.3- Passenger View Point	19
3.3.4- Car Safety of Children	20
4.CONCEPTUAL DESIGN IDEAS.....	22
4.1- Taxi Projects for the Future	22
4.2- Automobile Design Trends.....	24

5. MODIFYING AND DEVELOPING THE CURRENTLY USED TAXIS	31
5.1- Stages of Design, from Initial Sketches to the Prototype	33
5.1.1- Sketching	33
5.1.2- Physical Modeling	35
5.1.2.1- Conceptual Models.....	36
5.1.2.2- Experimental Models.....	40
5.1.2.3- The Prototype.....	41
5.1.3- Virtual Modeling (CAD).....	43
5.2- Analysis of the Current Taxis	45
5.2.1- Manufacturing Methods and Assembly of Mechanical Parts	45
5.2.2- Analysis of the Current Brands	46
5.2.3- Types and the Availability of Mechanical Parts.....	47
6. DESIGNING THE NEW VEHICLE.....	48
6.1- Body Parts of the Vehicle	48
6.2- Chassis of the Vehicle	50
6.2.1- Examination of the Chassis Types.....	50
6.2.2- Deciding on the Appropriate Type for the Chassis	53
6.3- Conceptual Sketches and Developments Proposed for the Project.....	55
6.3.1- Design Stages Followed in the Project	55
6.3.2- Conversion of the Existing Vehicle	58
6.3.3- Proposed Features of the Project	63
6.4- Evaluation of the Budget for the Realization of the Project.....	68
7. CONCLUSION.....	74
REFERENCES	78

APPENDICES

A: Presentation Boards - Technical Drawings.....	81
B: Presentation Boards - Conversion Stages	83
C: Presentation Boards - Service and Maintenance	91
D: Presentation Boards - Use Interface	95
E: Presentation Boards - Access Ramp Details	101

LIST OF FIGURES

FIGURE 1: DION ARCHIBALD, TRAFFIC, OIL ON BOARD, 2005	1
FIGURE 2: HORSE-DRAWN CARRIAGES	5
FIGURE 3: HORSE-DRAWN CARRIAGES WAITING FOR CUSTOMERS.....	5
FIGURE 4: LOGO OF THE CHECKER CABS ON THE SIDE DOORS	6
FIGURE 5: TIMES SQUARE (1934)	6
FIGURE 6: CABS WITH MEDALLIONS	7
FIGURE 7: NEW YORK CITY	7
FIGURE 8: TAXI WITH A BULLET PROOF PARTITION	8
FIGURE 9: A HANSOM CAB	9
FIGURE 10: AN EARLY UNIC CAB, MADE IN PARIS	10
FIGURE 11: AN AUSTIN 12/4 LOW LOADER TAXI	10
FIGURE 12: THE AUSTIN FXIII OF THE 1950S	11
FIGURE 13: THE AUSTIN FX4.....	11
FIGURE 14: THE AUSTIN TX4	11
FIGURE 15: TAXIS WITHOUT ENOUGH ROOM	13
FIGURE 16: CARTOON ILLUSTRATING THE PROBLEMS	14
FIGURE 17: A PARIS HORSE CAB DRIVER IN THE COFFEE BREAK	17
FIGURE 18: YELLOW CAB COMPANY DRIVERS, 1958.....	18
FIGURE 19: 1920S DIAMOND CAB STAFF	18
FIGURE 20: PRIORITY OF DRIVING FUNCTIONS.....	19
FIGURE 21: PENTAGRAM.....	22
FIGURE 22: HYBRID PRODUCT DESIGN + DEVELOPMENT (PERMAN, 2005).....	23
FIGURE 23: CITY CAB (CITY CAB, 2006)	23
FIGURE 24: FRONT VIEW OF THE “STANDARD TAXI”	24
FIGURE 25: ACCESS RAMP “STANDARD TAXI”	24
FIGURE 26: LANCIA SIBILO	25
FIGURE 27: THE SMART FOURFOUR STYLE.....	26
FIGURE 28: CADILLAC SRX.....	26
FIGURE 29: CHRYSLER 300 (2007)	27
FIGURE 30: MERCEDES-BENZ	27
FIGURE 31: AUDI.....	28
FIGURE 32: TOYOTA CAMRY.....	28
FIGURE 33: LEXUS LS 460	29
FIGURE 34: NISSAN ALTIMA HYBRID	29
FIGURE 35: CHEVROLET CORVETTE COUPE	29
FIGURE 36: REAR VIEW OF THE “STANDARD TAXI”	30
FIGURE 37: STRAPENTELI DOLMUŞ	32
FIGURE 38: STRAPENTELI DOLMUŞ	32
FIGURE 39: SKETCHES	33
FIGURE 40: TAPE DRAWING PROCESS.....	34
FIGURE 41: CLAY MODELING.....	36
FIGURE 42: WHITE MODEL	37

FIGURE 43: SEE-THROUGH MODEL	38
FIGURE 44: CLAY MODEL	38
FIGURE 45: HUMAN FACTORS PROTOTYPE	41
FIGURE 46: WORKING MODEL	42
FIGURE 47: FINAL MODEL	43
FIGURE 48: OPERATIONS IN CONSTRUCTIVE SOLID GEOMETRY	44
FIGURE 49: NURBS MODELING.....	44
FIGURE 50: DIGITIZING.....	45
FIGURE 51: COMMON USE OF DOĞAN AS TAXI IN TURKEY	47
FIGURE 52: TECHNICAL DRAWINGS OF THE TOFAŞ ŞAHİN (CAN, 1982).....	47
FIGURE 53: DAMAGED CAR (ONLY FROM ONE SIDE)	49
FIGURE 54: LADDER CHASSIS OF ISUZU PICK-UP.....	51
FIGURE 55: MASERATI TIPO 61 BIRDCAGE (1961) CUTAWAY DRAWING	51
FIGURE 56: UNIBODY CHASSIS OF FORD MUSTANG	52
FIGURE 57: CITROËN TRACTION AVANT (1934).....	53
FIGURE 58: FIAT VSS SUBSYSTEMS	55
FIGURE 59: ANALYSIS OF THE MECHANICAL PARTS	56
FIGURE 60: DESIGNING THE CHASSIS.....	56
FIGURE 61: DESIGNING THE FORM	57
FIGURE 62: USER AND DESIGN INTERACTION.....	58
FIGURE 63: DISASSEMBLING THE PARTS	58
FIGURE 64: MECHANICAL PARTS	59
FIGURE 65: BASE OF THE CHASSIS.....	59
FIGURE 66: CHASSIS OF THE VEHICLE	60
FIGURE 67: INSTALLATION OF THE INTERIOR PARTS.....	60
FIGURE 68: INSTALLATION OF THE BULLETPROOF PANEL.....	61
FIGURE 69: INSTALLATION OF THE DASHBOARD	61
FIGURE 70: INSTALLATION OF THE EXTERIOR PARTS.....	62
FIGURE 71: INSTALLATION OF THE ROOF PARTS	62
FIGURE 72: INSTALLATION OF THE EXTERIOR ACCESSORIES.....	63
FIGURE 73: DRIVER’S OFFICE	64
FIGURE 74: BULLETPROOF SECURITY PANEL	64
FIGURE 75: EXPLODED VIEW OF THE BODY PARTS (1)	65
FIGURE 76: EXPLODED VIEW OF THE BODY PARTS (2)	65
FIGURE 77: DEMOUNTABLE CHASSIS.....	65
FIGURE 78: PASSENGER COMPARTMENT.....	66
FIGURE 79: DOOR FRAME	66
FIGURE 80: PASSENGER COMPARTMENT WITH FOUR PASSENGERS.....	66
FIGURE 81: PASSENGER COMPARTMENT WITH TWO PASSENGERS.....	67
FIGURE 82: SEATING POSITIONS OF FOUR PASSENGERS	68
FIGURE 83: ACCESS RAMP AND CHASSIS	68
FIGURE 84: FIAT PALIO SOLE.....	72
FIGURE 85: HYUNDAI ACCENT	73
FIGURE 86: DACIA LOGAN	73
FIGURE 87: FIAT DOBLO	73

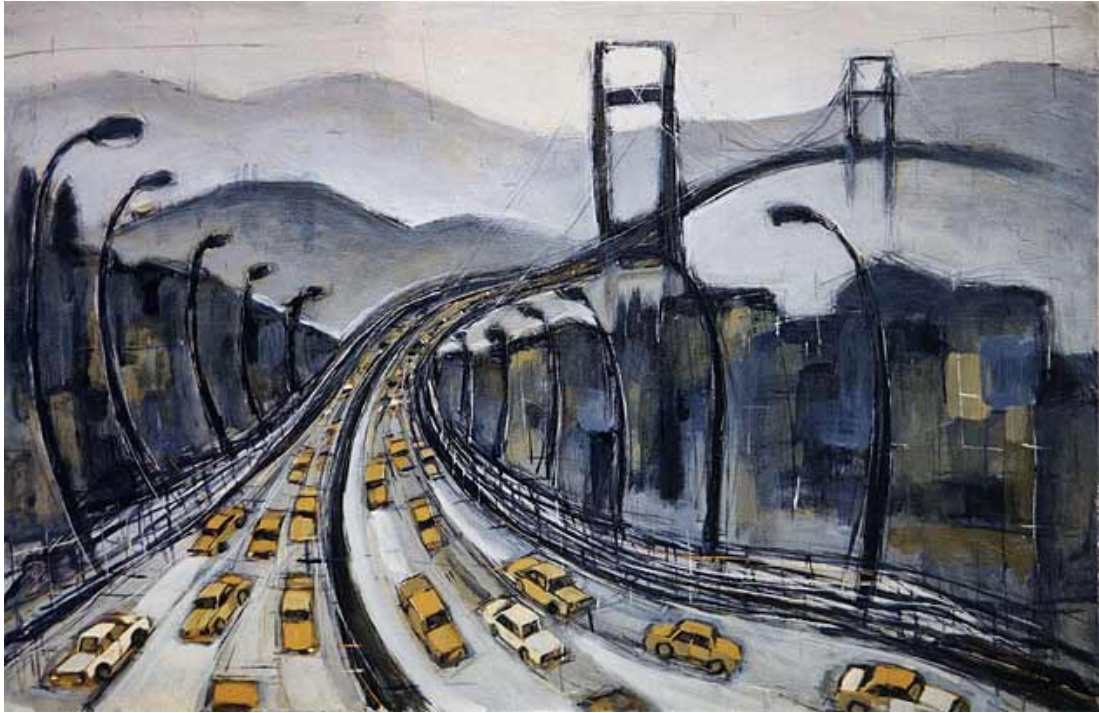

Figure 1: Dion Archibald, Traffic, Oil on board, 2005

CHAPTER I

INTRODUCTION

One of the major problems in growing cities is difficulties in transportation. Increasing number of the vehicles without control in the traffic causes problems in rush hours, and city transportation becomes highly time consuming and stressful. It is known that taxis occupy a significant place in traffic. Not using these transportation vehicles everyday does not mean that, they are not a part of the everyday life. Assuming that taxis occupy a large percentage in traffic, we can start arguing and questioning the functionality of the vehicles for the safety and comfort of the customers and drivers.

The taxi project aims to bring the current taxi to a higher quality to provide a better service to its users. In order to accomplish this, first of all the emergence of the taxi concept will be researched. The examination of the obstacles faced and the solutions provided throughout the development of the taxi will offer advantages for the design of the new taxi.

The previous concerns in the history of the taxi will be helpful in the analysis of the problems that the current users are facing. The examination of the previous and current concerns of the taxi system enable the statement of the problems to be addressed in this thesis.

The main goal of this research is to solve the problems and handicaps that passengers and drivers come across in the taxis and place new solutions to bring the taxis to higher standards for a more comfortable and safer journey. Current vehicles are not satisfactory in terms of providing adequate comfort and safety because their design is not suitable to be used as taxis. This project will try to figure out economical solutions for the owners of the current taxi vehicles and the users of the taxi system.

Developing and modifying the design of the current vehicles' chassis, body and interior elements while reorganizing and making use of the all mechanical parts can be an economical solution. As well as the preventing vehicles from being salvage, the utilization of the parts of the current vehicles in the project by maintaining the same spare part sellers and services that the owners are used to previously, brings further advantages.

Another area to be investigated is the recent trends in vehicle design and technological developments, in order to understand aesthetic expectations of the users. The recent production and design methods, also has to be examined to decide on the most applicable methods to be followed in this thesis.

The evaluation of the user expectations from the taxi service combined with the technological developments, recent trends and materials can provide solutions to elevate the quality of the taxi system. However, most fundamentally, it has to be understood that the taxi system is not simply a fleet of vehicles but "it also forms a spatial, economic, environmental and a social system" (Canning et al. 2005, p.9). In other words, Goldberger regards the concept of taxi as a "public space that moves" (Canning et al. 2005, p.6). Therefore, the taxi should not be simply seen as a vehicle, but a public space. Also, in some cases taxi becomes the icon of the city as explained by Patten " The taxicab is a symbol of New York to millions of tourists. It marks arrival and departure—the modern equivalent of a city gate. It is the space of entrance to the city. It frames the visitor's first glances. (Canning et al. 2005, p.17). The concept of the taxi, if approached with a better understanding has a significant role in showing the development level of a city.

CHAPTER II

HISTORY OF THE TAXI

In order to satisfy the expectations of the taxi users, the concept of taxi and its development throughout history should be examined in the design stage. The consideration of the previously studies on the expectations, obstacles and the answers developed to overcome the problems will provide a better design approach, in terms of offering new and advanced solutions with the integration of today's technology.

2.1- The History of the Yellow Cab (America)

At the end of the 19th century, automobiles began to appear throughout the USA. Some of these cars were hiring themselves as an alternative to horse-drawn carriages. However, the electric-powered engines were slightly impractical due to batteries weighting nearly four hundred kilograms. In 1899, there were around hundred carriages for hiring on New York streets. It was believed that these cabs¹ provided a cleaner, quieter and faster way to travel (Taxi-L World of Taxis, 2006).

¹ "Cab is a shortening of cabriolet, reflecting the design of the carriage. It replaced the hackney carriage as a vehicle for hire; with the introduction of clockwork mechanical taximeters to measure fares, the name became taxicab" (Wikipedia contributors, 2009).



Figure 2: Horse-drawn Carriages

In 1907, New York Taxicab Company imported six hundred cars from France which were powered by gasoline. With the accessibility of gas-powered cars and the introduction of the taximeter,² their popularity started to grow. There were six large fleets and thousands of independent drivers. However, with the rates at fifty cents a mile, cabs were still serving toward the relatively wealthy. By the 1920's economic potential of taxi industry was realized. At this time largest fleets were owned by major manufacturers like General Motors, Ford Motor Company and Checker Cab Manufacturing Company. Checker Cabs produced the large yellow and black taxis, that became a recognizable symbol of New York (Taxi-L World of Taxis, 2006).



Figure 3: Horse-drawn Carriages waiting for customers

² “Fitting of a taximeter was made compulsory in New York and London in July 1907. Early taximeters were totally mechanical in operation and the clock that recorded waiting time had to be wound by hand. Meters of the 1960s and 1970s had a built-in electric clock but today, taximeters are fully electronic and operate on a time basis at speeds between zero and ten mph” (Dimmock, 2005).



Figure 4: Logo of the Checker cabs on the side doors

In 1930, as taxi companies grew, there was a need for enforceable regulations. Cab drivers suffered from unfair labor practices, and passengers suffered from price gouging. Police and Taxicab Commission were not able to control the corruption. The problem got even worse during the depression with the increase of drivers, which then led to one of the biggest strikes in New York City in 1934. As a response to the strike, taxi licenses and the medallion system were introduced. Medallions were plates that are placed on the car's hoods, and by limiting the number of the medallions issued, the government gained more control over the taxi industry (Taxi-L World of Taxis, 2006).



Figure 5: Times Square (1934)



Figure 6: Cabs with medallions

By mid-century, taxis became an important part of urban transportation, servicing with approximately 12,000 vehicles. In 1960, New York City taxis were painted yellow which provided the prevention of unofficial taxis and helped them to be distinguished. In 1970's and 1980's taxi related organizations started to appear in order to make services safer for the drivers, the passengers, and the environment. Also at the time, violent crimes against taxi drivers had grown and the bulletproof partition between the front and back seats started to become more common (Taxi-L World of Taxis, 2006).



Figure 7: New York City



Figure 8: Taxi with a bullet proof partition

“Today there is 12,187 taxis and some 40,000 drivers in New York City. With the Checker cabs retired and mini-vans and SUVs in their place... They take more than two hundred million passengers almost eight hundred million miles a year. They make more than one billion dollars in revenue and drive passenger less for almost a million miles a night” (*Taxi-L World of Taxis, 2006*).

This points out the importance of taxi system, in terms of the space that they occupy in traffic, providing a significant service, employment and business. Therefore, it has to be emphasized again that, such a significant service business requires a higher attention in developing countries.

2.2- The History of the London Cab (Europe)

The concept of taxi emerged in London with the introduction of Hackney carriages³. They first appeared in 1588 by 1760's and there were over a thousand carriages in London. In 1823, carriages called cabriolet (cab) were introduced which became very popular for its speed and comfort. In 19th century two types of cabs were commonly used. One was the two-wheeled Hansom⁴, and the other was the

³ Hackney carriages receive their name from the French word 'Hacquenée' which means a horse for hire (Dimmock, 2005).

⁴ A hansom cab is a kind of horse-drawn carriage designed and patented in 1834 by Joseph Hansom, an architect from York. The vehicle was developed and tested by Hansom in Hinckley, Leicestershire, England. Originally known as the Hansom safety cab, its purpose was to combine speed with safety, with a low centre of gravity that was essential for safe cornering. (Wikipedia contributors, 2009).

four-wheeled carriage with the ability to carry luggage serving mostly at railway stations (Dimmock, 2005).

However, with the First World War, the industry disappeared and the last horse cab license was cancelled in 1947. First motor cabs used in London were electrically powered. In 1897, 25 of them were introduced and by 1898, 50 electric-powered cabs were being used. However they were involved in a number of accidents including one fatal accident which made the citizens lose their confidence in motor cabs, and in 1900 they were removed. In 1903, gasoline powered cabs were introduced. By 1906 there were around a hundred gasoline powered cabs in London. In the same year, rules for motor cab design were issued. One of the regulations requiring a 7.5m turning circle ability for the cabs, caused many manufacturers to withdraw their products (Dimmock, 2005).



Figure 9: A Hansom Cab

With the First World War the production of taxis came to end when the only manufacturing company Unic was used to produce amunitions. Also most of the cab drivers were called up to fight. In 1919, first post-war cab was introduced by William Beardmore & Co. Ltd. and was followed by other companies. In 1929, a new cab for

London was launched in the market by manufacturer company Austin. Because of its height it became very successful, and sold much more than the other brands. In 1934, a new Austin model, the 'Low Loader' became the most common model of the decade, since it was inexpensive, reliable and easily obtainable. Again with the start of the Second World War most of the young cab drivers were called up to war and production of cabs was stopped and once more the industry went into decline. After the Second World War, there was an urgent requirement for new taxis. Manufacturers introduced new models, and once more Austin dominated the market with Austin FXIII in 1948 (Dimmock, 2005).



Figure 10: An Early Unic Cab, made in Paris



Figure 11: An Austin 12/4 Low Loader taxi

Austin's next taxi was introduced in 1958 was named as FX4. This vehicle became highly popular and remained in continuous production with various modifications, including seven different engines, for 39 years. Between 1947 and 1997 Austin remained in the market producing different models and engines.



Figure 12: The Austin FXIII of the 1950s



Figure 13: The Austin FX4

In 1997, famous FX4 was replaced with TXI by London Taxis International. An updated version of TXI, named TXII with a Ford engine followed but was unreliable and unpopular. In November 2006 the TXII was replaced with the TX4, which had the same body and chassis with TXII, but used a VM turbocharged diesel engine. It was named the TX4, instead of TXIII because it fulfilled the Euro4⁵ exhaust emission regulations (Munroe, 2005).



Figure 14: The Austin TX4

⁵ European emission standards define the acceptable limits for exhaust emissions of new vehicles sold in EU member states. The stages are typically referred to as Euro 1, Euro 2, Euro 3, Euro 4 and Euro 5 fuels for Light Duty Vehicle standards (Wikipedia contributors, 2009) .

Examination of the developments and problems that the taxi faces throughout history reveals that the major problem is the uncontrolled increase in the number of taxis. In this rapidly developing market, in order to take part in this business, the demand lies highly on the cheapest vehicle with most common and affordable body parts. However this situation shows that the significant issues of functionality, safety and comfort are disregarded. Throughout history, European interest in taxi design has shown developments in these design issues where American design has a more recent background.

CHAPTER III

PROBLEMS OF CURRENTLY USED TAXIS

3.1- Ordinary Family Sedan Cars Being Used as Taxis

The main problem of the taxis, which are currently used in traffic is that, they are not especially designed for being used as a taxi. The ordinary family sedan cars are preferred to be converted into taxis because of their low selling prices and available cheap parts. However these cars cannot provide enough comfort and safety since they are not designed to be used as a taxi. The expected functions of the taxis are rather different than the functions of the ordinary cars. Therefore adaptation of the ordinary sedan cars simply by changing its color to defined taxi color and adding a radio communication system does not provide an adequate taxi (Canning et al. 2005).



Figure 15: Taxis without Enough Room

3.2- Design Insufficiency of the Current Taxis

Taxis which are currently operating in the traffic do not have a suitable design to provide adequate comfort, functionality and safety. Under the awareness of this inadequateness of the mentioned design aspects, the main goal of this research is to solve the problems and handicaps that people come across in the taxis, and place new solutions to bring the taxis to higher standards for a more comfortable and safer journey. A taxi's and the driver's aim should not only be transporting the customer from one location to the other, but also, it should provide optimum safety, functionality and comfort under different circumstances. There may be customers with luggage to be carried with them, or they may be accompanied with a disabled customer or disabled customers may be travelling alone, and also there may be family members with babies and push chairs.



Figure 16: Cartoon Illustrating the Problems

3.3- Required Design Criteria

Taxis, which are an important part of the city transportation can not reflect the 21st century design knowledge. The main reason for that is using ordinary family cars as taxis. Design criteria of the ordinary family cars does not match with the taxi requirements, because they involve different functions, specifications and passenger spaces. The main design criteria for the proposed vehicle must be satisfactorily fulfilling these subjects. For example, the body shape of the taxi must be designed with the intention of creating easy accessibility with high roofed and larger compartments, rather than aerodynamic, low roofed body forms. Using high roofed cabin forms provide better accessibility for the disabled passengers access, and also to the passengers with push chairs who are carrying babies (Schaller, 2005).

Together with the comfort and functionality of a taxi, the security of a driver is also highly important issue which comes along with the design of the taxi. Driver communicates with many different people while working, and sometimes they can be threatened with their lives by the passengers especially in night shifts (Farley, 1999).

Semih Kaçanoğlu, chairman of the İstanbul Chamber of Taxi Drivers, has announced that, for the past eleven years there have been 86 taxi driver murders in İstanbul, 33 have been killed in İzmir for the past 5 to 6 years (Hürriyet, 2005). These large numbers of crimes pointed out that separators between the driver and customers must be provided in Turkey. In developed countries, using a lead proof separator between the driver and customer lowered the amount of murder cases among taxi drivers, which shows that appropriate design can bring a solution to security problems. Also, the feeling of insecurity while driving leads to additional problems in another crucial subject, which is the life safety of both passenger and the

driver. The driver being under pressure and stress might result in possibility of losing his/her concentration in the traffic and increase the risk of an accident.

Even though there are effective solutions for reducing security problems, it was reported that due the high rate of governmental taxes for installing a lead proof separator, drivers tend to prefer taking the risk. This means that the government, instead of providing a better security, discourages the use of such precautions (Kaban, 2006).

3.3.1- Driver View Point

Taxi can be considered as the office of the driver, therefore the design of the vehicle should be derived from ergonomic considerations; which will be explained further in the next chapter, to offer comfort in long term use. Also, the interior materials should be selected in order to make available hygiene. Silent and non vibration smooth chassis with good ventilation features in all weather conditions must be provided with the aim of enabling the driver to tire less and offering an improvement in their working environment. Allowing a wide vision range to the outside by reevaluating the windshield designs is another area which has to be improved (Canning et al. 2005).

Easily operated vehicles supplied with technological equipment such as road mapping system working with GPS technology are helpful both for the driver and the passenger. For the safety purposes the radio systems should be provided with a hands free option. A panic button should be supplied for the driver in case of an emergency. This signal can be activated by the driver without being realized by the passenger if there is a threatening situation.

Design of the cockpit should also provide some functional spaces for the needs of the driver. The dashboard of the vehicle should be designed to be clearly visible. Also it could be equipped with additional warning signals, which are related to the passenger safety; for instance the driver should be able to know if the passenger door is properly closed or if the passenger is wearing a seatbelt.

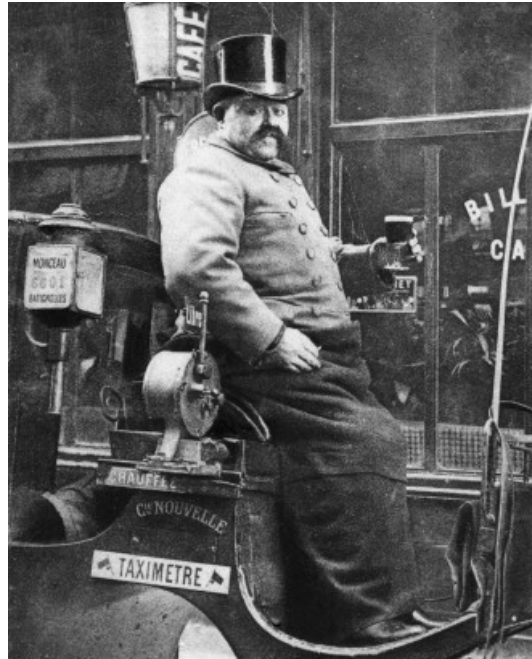

Figure 17: A Paris horse cab driver in the coffee break

Another important issue concerning the drivers is the attitude of the passenger towards them. This is an area that drivers can improve by paying attention to certain things, such as their appearance and the taxi's cleanliness. In the design stage, easily cleanable surfaces and materials can be used, but the maintenance is still drivers' responsibility.



Figure 18: Yellow Cab Company drivers, 1958



Figure 19: 1920s Diamond Cab Staff

3.3.2- Ergonomics as a Fundamental Aspect of Automobile Design

Ergonomics in car design became a more significant issue as the demand for comfort and safety increased. Without the ergonomic considerations, long periods of driving could become significantly tiring and further, it could cause postural problems. Also the use of various controls could become harder to operate and reactions in moments of danger could be blocked. The ergonomics of the vehicle driving position has many fundamental aspects. Ergonomic design is involved with determining the technical specifications of a product to meet the cost and the technological requirements.

First of all, the automobile ergonomist provides a definition of functions and analysis of tasks. In this stage functional analysis of the driving position is established in order to determine the accessibility of the controls to be placed in the vehicle. This involves an understanding of the driving functions and identification of the priorities among vehicle controls. The hierarchy among controls is established by the examination of safety and comfort as shown in figure 20.

DRIVING FUNCTIONS		
BASIC	NECESSARY	ADDITIONAL
<ul style="list-style-type: none"> - Ability to change vehicle speed - Ability to change vehicle direction - Ability to stop vehicle - Signaling - Acoustic or luminescent warning in emergency 	<ul style="list-style-type: none"> - Switching on/off windshield wipers - Open and closing driver's window - Switching on/off lights - Starting engine - Mirror adjustment - Seat adjustment - Securing seat belt 	<ul style="list-style-type: none"> - Control radio system - Opening ashtray - Opening glove compartment - Opening gasoline lid - Opening engine hood - Opening trunk - Opening doors

Figure 20: Priority of driving functions (National Highway Traffic Safety Administration, 1996)

This stage will point out the problems that will point out the issues to be considered in the next stage. However it is important to note that the solutions cannot always meet all the requirements at the same time, therefore it is necessary to make optimal decisions to suit the largest number of users. This approach also reveals the necessity to know for whom the product is intended. Then the third stage is the application of the decisions made in previous stage to provide the required efficiency and safety.

3.3.3- Passenger View Point

From the passenger view point, taxi should serve appropriately to its passengers who have different expectations. Passenger can be a disabled person with a wheelchair, carrying luggage, a push chair or there may be a crowded friend group or a family. Discovering out the kinds of the taxi passengers and classifying them according to their needs, abilities and disabilities becomes important for the design phase, in order to solve the problems and handicaps they come across. The most important problems that design of the taxi should try to answer are providing easy

access for the passengers and satisfying all the needs of them while offering a comfortable and safe journey.

Passenger space of the car can also be equipped with some additional features adopting recent technologies. For example, LCD displays can be informing the passengers about the route which they will follow by using GPS system. This screen can also supply the passenger with the information about the city. For instance, it could display the historical background of certain landmarks and significant spots in any desired language. Also for the payment, credit card machines can be placed in the vehicles. This idea can be further developed by creating specific cards for the taxis or they could be combined cards for the other public transportation vehicles as well. This idea will be making the payment easier and more importantly increases the security of the driver since the driver will not have to carry large amounts of cash.

3.3.4- Car Safety of Children

One of the major problems that the passengers face while using taxis is the child safety. None of the current vehicles has an equipment to provide a safe journey for children.

The research report of U.S. National Highway Traffic Safety Administration indicated that there were over 600 children who died in car accidents in one year, and approximately 250 children that are not using or misusing safety protection devices in U.S.A. In addition, according to the investigation concerning children's injuries caused by car accidental impact revealed that, "the most injured portion were head, face and belly and even if using or not using safety protection devices" (Lai, 2000).

Fastening the child stably in the safety seat is an effective method. This could prevent the child from flying away from the seat during collision. However, the impact energy will affect the unfastened body parts such as hands, feet, head and neck. The neck is located in such a position that undertakes largest torque moments during impact. This is the reason for head and neck injuries to be more common.

The safety belt is not also very efficient in fixing the safety seat. This is because the safety belt cannot pull back the safety seat immediately, and the safety belt will be pulled out. It could cause the safety seat to fall off the car seat or to be displaced, to avoid this problem the seat belt attached to the safety seat has to be locked.

According to the age and the weight of the child, different arrangements have to be made which requires a modular design for the placement of the child seat. Below are the regulations for the child safety in vehicles.

The 2006 booster seat law includes a four-step progression for effective child safety protection in vehicles. First of all the rear-facing child safety seat in the back seat is required when the child is less than 1-year-old or weighs less than 10 kilograms. On the other hand, the forward-facing child safety seat in the back seat is required when the child is at least 1-year-old but less than 4-years-old and weighs at least 10 kilograms but less than 20 kilograms. Another necessity brought by the law is that the booster seat is required when the child is at least 4-years-old but less than 8-years-old and weighs at least 20 kilograms but less than 40 kilograms and not taller than 150 centimeter. The final important point is the requirement of safety belt when the child is 8-years-old or older or weighs higher than 40 kilograms or taller than 150 centimeter (Implementation of the new booster seat law, 2006).

CHAPTER IV

CONCEPTUAL DESIGN IDEAS

4.1- Taxi Projects for the Future

The developments in automobile manufacturing and design is reflected to the taxis only if a family sedan car is purchased to be used as a taxi. Although, there are significant developments in the vehicle industry, the taxi design cannot fully benefit from these advancements since it requires specific attention with a different understanding in terms of design. Therefore, it can be said that, taxis serve its customers with same design without any improvement for long years. This subject became important for many different design groups and they started to develop some conceptual vehicles. The illustrations below are the some conceptual design ideas prepared by design groups, Pentagram and Hybrid Production Design + Development.

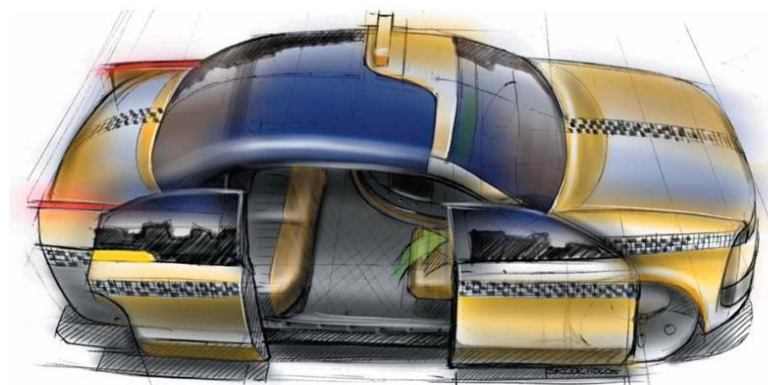

Figure 21: Pentagram



Figure 22: Hybrid Product Design + Development (Perman, 2005)

At a first glance, similarities between the different designs can be detected. Some of these are enlargement of wind shields as much as possible which nearly occupies the most surface area on the body. Also the design of large doors for providing easy entrance can be seen as a common feature. Some of the design groups also tried to minimize the dimensions of the vehicle as long as the interior space could still provide enough space for the needs of the passengers.



Figure 23: City Cab (City Cab, 2006)

Figures 24 and 25 show the "Standard Taxi" which was designed by The Vehicle Production Group LLC. Main features of the vehicle are explained by the group as follows:

“The Standard Taxi has been engineered to be durable, cost-efficient to operate, and easy to maintain. Groundbreaking features such as interchangeable door panels, fenders and bumpers make this vehicle a unique purpose-built taxicab which even has a powertrain that is calibrated for taxi-duty driving cycles to improve fuel economy and emissions. With a focus on safety, the Standard Taxi is designed with anti-lock brakes, a strong frame and body structure, and energy-absorbing bumpers. The easy-to-maintain interior helps to guarantee that passengers will always have clean seating surfaces and floors. With a focus on accessibility for all, the Standard Taxi provides seating positions for four passengers in the rear compartment, and additional space for a common wheelchair or scooter...” (The Vehicle Production Group LLC, 2006).



Figure 24: Front view of the “Standard Taxi”



Figure 25: Access ramp “Standard Taxi”

4.2- Automobile Design Trends

In the automobile industry, design has an outstanding significance for commercial success. Design has to be innovative while providing solutions for technical demands such as safety and environmental protection standards (Car Design News, 2005).

Transparency

Recently, transparency of the vehicles is a growing trend. The windows and sunroofs are getting larger and further in some cases other body parts are constructed from transparent or translucent materials.

This was illustrated in the Bertone-designed Lancia Sibilo concept in 1978, which had a dark brown body feathered into a heavily tinted glasshouse.



Figure 26: Lancia Sibilo

Mostly, the trend for translucency will be made possible by the use of polycarbonate plastics. The incorporation of these materials as well as creating a visual appeal also provides weight reduction.

Even further, the translucent parts will be put in to use to “offer new user benefits, such as enabling the driver to see the curb when parking, see through pillars when making lane changes and also enable children and shorter occupants to better see out of cars” (Patton, 2007).



Figure 277: The Smart FourFour Style

Recently an enlargement of the sunroofs is a recognizable change to provide light and sense of openness especially for backseat passengers. Double sunroofs and panoramic moon roofs have already appeared in recent cars.



Figure 288: Cadillac SRX

Higher Beltlines

The beltline has an important status in the appearance of the car. The beltline splits the windows from the lower body, therefore significantly structures the final appearance. The recent trend is towards getting higher beltlines, as shown in Chrysler 300.



Figure 299: Chrysler 300 (2007)

The reason behind this trend is the popularity of the SUV's higher driving positions and higher beltlines giving lower vehicles this impression of height. Also, another reason is the increase in people's height. Thirdly the safety standards are causing a raise in the beltlines. Side impact standards state that slab-like sides and higher beltlines provide more solidity and protection.



Figure 300: Mercedes-Benz

Larger Grilles

Grills have shown a growing trend since 1990's. Grills are considered as giving an identity to the vehicle in other words the 'face' of the vehicle. For instance, Audi is recognized by large front grill extending from the hood to the lower edge of the bumper which was not the case several years ago. However, there is also a

practical reason for grilles getting larger. As the horsepower of the engines' increases, the air requirements to cool down the engine also increases, and larger grilles provide better air circulation.



1996



2008

Figure 311: Audi

Aggressive Faces

In recent vehicles, softer lines of the last decade have been replaced with more 'aggressive faces' consisting of more angular lines. The faces of both cars and trucks used to be dominated by elliptical shapes, which are converted in to sharper corners and straighter lines as seen in Toyota Camry.



1994



2007

Figure 322: Toyota Camry

Headlights and Taillights as Jewelry

The use of chrome edges, mirrors, lenses and LED lightings made the headlight and taillight assemblies more complex. Designers call them the “jewelry” of the vehicle as Patrick Schaivone agrees. “Bending sheet metal is part of design, but you also have your jewelry items — like lighting, which is going to be bigger and bigger” (Patton, 2007).



Figure 333: Lexus LS 460



Figure 344: Nissan Altima Hybrid

Larger Wheels

The wheels have shown an enlargement in size throughout the years. This trend is seen not only in SUV's and sports cars but also the family cars have adapted the enlargement of wheels. It is assumed that larger wheels provide a more 'powerful' look. But the problem with large wheels is that they are not practical and comfortable, however with improved suspensions this problem has been overcome.



Figure 355: Chevrolet Corvette Coupe

One of the conceptual taxi designs, which was explained in the previous section, appears to be falling behind when compared to the modern design trends in automobile design. “Standard taxi”, which was designed by the “The Vehicle Production Group LLC”, appears to be adequate in many terms of functionality and high maintenance of the vehicle. However its form and visual aspects are not following the current trends and therefore cannot reflect the "modern look" (Harrell, 2006).



Figure 36: Rear view of the “Standard Taxi”

A new concept of taxi as well as considering the security, functionality and safety issues should also reflect contemporary understanding of design and trends, in order to provide both functionally and aesthetically approached design brief.

CHAPTER V

MODIFYING AND DEVELOPING

THE CURRENTLY USED TAXIS

The changes that are proposed in this project are based on modifications and developments on an existing vehicle. The modification will provide limited changes on the vehicle which can then be developed by additional parts and systems.

Modifications can either be addressing the aesthetic concerns of the vehicle owner or it could be done to provide functional changes. 'Istanbul Dolmuş' which has been used in 1950's can provide an example for modification. The concept of 'dolmuş' started with four passengers using one vehicle to reach to their destinations. After its appearance in 1930's in Istanbul, it was established in other cities in Turkey. This Turkish invention is still being widely used, but in 1930's, automobile brands such as Desoto, Plymouth, Dodge, Chevrolet and Buick served for this purpose. The most interesting fact about these vehicles used as 'dolmuş' is that almost none of them was in its original size. They were usually cut into half and elongated by additional parts. This enabled three more passengers to be carried in the folding seats added to the new section, which raised the passenger capacity to a total of ten. These folding seats and the elongated vehicles were called 'strapente'. Usually these

seats were uncomfortable and required the passenger to travel in a back-hurting posture. The back seat carried four passengers, additional 'strapente' section carried three and in the front two more passengers except the driver were able to travel.

This modification shows an example of an economic way of providing changes in order to satisfy transportation demands even it is an uncomfortable journey. However for the economical concerns in 1930's it provided a solution. Therefore, it can be said that, providing the required comfort combined with the technological advancements, modification can still provide economic solutions.



Figure 37: Strapenteli Dolmuş



Figure 38: Strapenteli Dolmuş

In this project, in order to provide the passenger comfort various design methods are employed for the new vehicle design concept to fully address the user's needs. The examination of drawings and models in terms of the advantages that they provide carry a high level of importance for decision making stage of a newly developed design project.

5.1- Stages of Design, from Initial Sketches to the Prototype

As in many different areas of design, automotive design also starts with transferring the design ideas and initial decisions in to 2D sketches and technical drawings, then continues by building 3D models and prototypes. These three phases can be summarized as; *sketching, modeling and production* (Tumminelli, 2006).

5.1.1- Sketching

Sketching is the earliest stage of the design process and a relatively quick way to visualize ideas, themes and styles. Usually in this stage, the designer creates dozens of sketches to evaluate and to be able to choose the most suitable one among them. Then, these sketches will be further developed to prepare the ideas to the next phase.

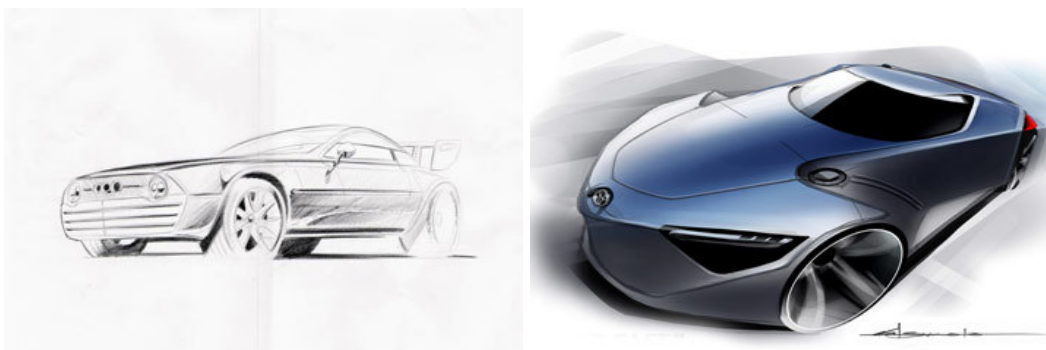

Figure 39: Sketches

After producing these small size sketches, automobile designers usually create concept sketches of cars in larger or even full size drawings on vertical surfaces, sometimes on walls, which enable the creation of a full size view of the car's form. The main reason for this is that the designers and the managers prefer to evaluate the principal shapes of a design in its early stages. This is critical to avoid any unpleasant surprises which might occur if only small scale sketches were used to make design decisions. Meanwhile, it is important to note that the end product becomes very costly to be revised, since the mass production systems (machines, molds, etc.) are prepared accordingly.

Tape Drawing

Another type of full size sketching is "Tape Drawing" which is specifically used in automotive design, and enables sketches to be created not by using pencil and paint, but with a technique where black photographic tapes are laid onto the drawing surface. While working with large scale size sketches, tape drawing is more functional over freeform sketching due to its ability to create smooth and continuous curves without using any physical aids (Car Body Design, 2006).



Figure 40: Tape Drawing Process

Computer Aided Sketching Using Vector Programs

Later with the development of the computer technology, tape drawing techniques were carried on to the digital media and by using vector programs such as “Adobe illustrator” or “Corel Draw”, the concerns of the continuity of the curves simply overcome.

5.1.2- Physical Modeling

3D models can be much easily apprehended and discussed compared to 2D drawings, both by the professional designers and people from other professions, such as company directors and customers.

With the purpose of experimenting alternative forms, designers may choose any suitable technique for producing their 3D models since modeling can be realized by using several ways and means. But at the very first hand, one should divide models in to two basic groups namely; *realistic physical models* and *computer based virtual models*.

In the design process, 3D physical models are used for various purposes. First, they are constructed for aesthetic considerations such as developing the shape of a product, defining the final form of a product, and evaluating colors and surface finishes. They are also used for experimental purposes such as demonstrating working mechanisms or testing its aerodynamic or ergonomic performances.



Figure 41: Clay Modeling

In the following sections physical modeling techniques and types will be explained and their aid to the designer will be discussed. Models are constructed to serve different purposes and to help the designer in the design process. Models built for creating the form are called "conceptual models", and the models built for testing the functionality are "experimental models". Then the prototypes are build, where all the final decisions are applied upon, to be certain about the design, before going in to production.

5.1.2.1- Conceptual Models

Conceptual models are usually constructed to aid the designer on the decision making stage about the form of the vehicle. But it can also be helpful for the non-designers to easily interpret and evaluate the design ideas.

The types of conceptual models which will be explained are subdivided in terms of the material used for their production, the function they serve and their detailing options for reducing time required for their production.

These models can be explained as follows:

Sketch Models

These models are 3D physical models made in soft and ephemeral materials in the early stages of concept/form development. These are quick, scale models built from clay, foam, cardboard, paper, etc. They may demonstrate limited aspects of product's function.

Scale Models

These types of models are often used in transportation design, for making decisions on the issues related to size. Scale models can be used for anthropometric evaluations, but cannot be tested with human subjects.

White Model

White models represent the form without any color or graphics. They are painted white in order to evaluate the form of a product and the surface smoothness. It is a well-detailed model, not like a sketch model.



Figure 42: White Model

See-through Models

In see-through models, glass areas are actually transparent, whereas in all clay models they are not. These models provide a better understanding of the form by

displaying the solid/void relationships. They can also be used for some experimental tests such as exterior visibility of the driver and the passengers.



Figure 43: See-Through Model

Material Types Preferred in Conceptual Modeling

Clay Model

Clay modeling is one of the oldest and most traditional methods used in car design. Studios are divided in their preferences of computer models over clay modeling but many believe that, it remains as one of the best ways to visualize the developing design in three-dimension.



Figure 44: Clay Model

A model made from a type of clay in a wax medium, used mainly by transportation designers to shape the exterior and interior details of a vehicle. Clay

modeling uses additive and subtractive methods and it is also quite stable. Skilled craftsmen can achieve very subtle, accurate results.

There are several stages of producing a clay model. First, the scale of the model is determined. Using a package drawing or a profile sketch, the vehicles dimensions are worked out and the scaled dimensions are calculated. Using the core dimensions, a rig is built. A rig is designed to be a solid working base for the model, as it is built and developed.

In the case of small scale models - such as 1/4 scale - the rig will be designed to be mounted on a bench where modelers can stand around to work on the model. It is often preferable to position a model to create the most realistic perspective. In addition to providing a base for the model, building the rig also reduces the amount of clay used on a model. Clay has been used since the earliest stages of car design and emphasizes the strong links between three-dimensional automotive styling and sculpture.

Foam Model

Today, several manufacturers produce rigid synthetic boards for prototyping, styling, and tooling applications. They are more costly materials than wood, however the advantages of using tooling board materials lower their total cost and time of a project to reasonable levels.

Tooling-boards are generally classified by density, encompassing a wide range of options, from medium-density foams to very dense, solid-plastic planks. This allows users to have a range of materials to choose from according to requirements, while controlling costs. Each tooling-board type has its special use,

there are several common advantages that distinguish them from alternative materials such as ease of machining, dimensional stability, easily bonded and repaired and easy surface finishing (Noblet, 1993).

5.1.2.2- Experimental Models

Experimental models, in contrary to the models constructed for developing the form, are created for performing tests related to the functionality and ergonomy aspects. In other words they are used for studying the physical aspects of the design. Since these models serve for testing purposes, the materials that are used, methods applied and the quality of the product is not highly important. The important issue here is the realization of the design ideas physically and making them adequate to perform the required tests. For instance, if the experiment aims to test the ergonomic aspects of the vehicle, for the driver, then only the parts which are related to the driver are assembled to create that section of the vehicle.

Human Factors Prototype

Human factors prototype is created to test the ergonomics but does not indicate the final appearance. The sitting position of the driver and the passengers is observed.

In these models, actual vehicle parts such as the seats and the steering wheel can be used and these parts do not necessarily have to be the ones designed for the vehicle that is being tested. The important point is setting the exact space, as proposed in the design.



Figure 45: Human Factors Prototype

Buck Model

In this model, a full size skeleton-type construction of a vehicle interior is constructed to test the driver visibility, driver and passenger comfort and similar concerns.

Color Study Model

This is a model that is used only to test the color schemes and finishing. Moldings of a product may be sprayed with variety of pre-determined colors for evaluation.

5.1.2.3- The Prototype

The third group of the physical models are mainly used in the final presentation of the design, where the product is exhibited in an automobile show. These are also the models where final discussions and decisions are made upon. After the revisions are made, these models are used as a reference in the production stage. The final molds and geometries are usually developed in conjunction to these models (Roozenburg, Eekels, 1995).

Rapid Prototyping

Models produced via rapid prototype machines are manufactured from components outputted by computer-generated models. This modeling technique is a fast way of construction without requiring any labor. It is practical and precise enough to produce models for the final evaluation stages but only within certain size limitations. However, due to the involvement of highly expensive technologies, the technique is accepted as a costly way of production. Items with reasonable sizes and delicate details, such as the dashboard parts or door knobs can be produced with this technique.

Working Model

This is a model where the appearance and some critical functional qualities are accurately depicted.



Figure 46: Working Model

Final Model

It is the 3D physical model imitating the materials and details of the final production piece as much as possible. In some cases the "Final Model" is the definitive design specification, and is used instead of engineering drawings or CAD models.



Figure 47: Final Model

High-Fidelity Prototype

High-Fidelity Prototype is a fully functioning, 3D physical model which is also very similar to the real one. They are used for consumer tests, product launches, for ramping up to full-scale production and have all the form, function color and feel of the final production product. However these models are very costly to produce and they are usually constructed only when a large mass production is planned (Fenton, 1996).

5.1.3- Virtual Modeling (CAD)

There are different methods for creating computer based 3D models. Some of the most commonly used ones are Constructive Solid Geometry modeling and NURBS modeling.

Constructive Solid Geometry Modeling (CSG)

Constructive Solid Geometry Modeling is a technique used in solid modeling which allows a modeler to create a complex surfaces or objects by using Boolean operators (addition and subtraction of 3D elements) to create objects. Often CSG presents a model or surface that appears visually complex, but it is actually combination or de-combination of 3D virtual objects (Wikipedia Contributors, 2006).

Operations in constructive solid geometry

Boolean union

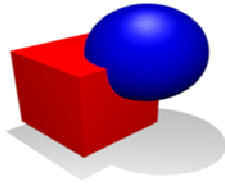

Boolean difference

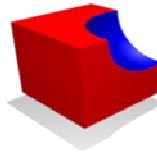

Boolean intersection



Figure 48: Operations in Constructive Solid Geometry

NURBS Modeling

Non Uniform Rational B Spline is a mathematical model for generating and representing curves and surfaces. In this technique the CAD program⁶ allows the user to make alterations on the model surface by enabling the movement of the control points of the curves which creates the surface.

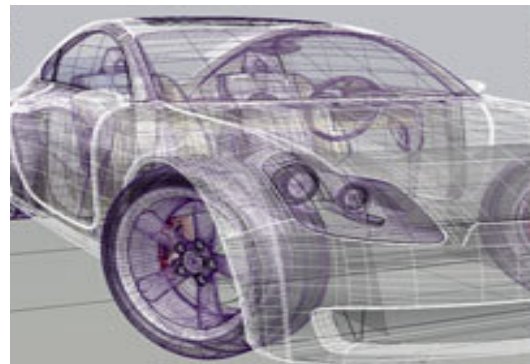
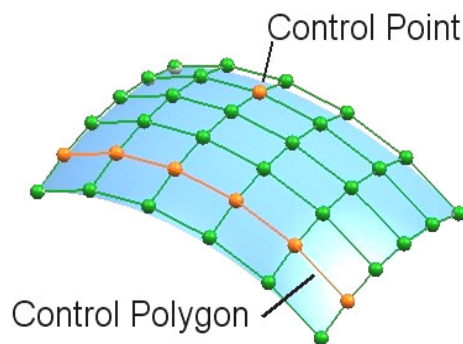

Figure 49: NURBS Modeling

Digitizing

Digitizing is the process of converting 3D physical forms into the virtual computer models. It is made possible with the optical sensors which are measuring and scanning the forms to obtain some coordinates from the surfaces and edges. This

⁶ Rhinoceros is the most commonly used CAD program that bases its 3D modeling method to NURBS modeling technique.

process is generally used in the automotive industry for reverse engineering, during analysis and quality control applications. Digitizing started to be a necessary part of the automotive design process, because it enables the designer to measure and convert the physical models in to highly detailed CAD models. This way, further developments and feedback for mass production can be obtained with the help of computer based programs (Archer, 1994).

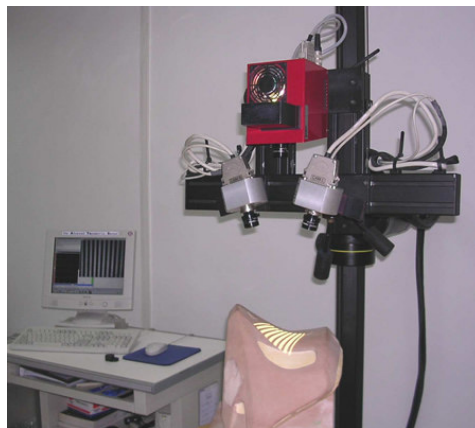

Figure 50: Digitizing

5.2- Analysis of the Current Taxis

5.2.1-Manufacturing Methods and Assembly of Mechanical Parts

Almost all of the cars which are being used as a taxi were constructed with unibody method where body and chassis are not detachable and made up of welded parts (see section 5.2.1.1). In this manufacturing method the body creates the enclosed space and it also carries all the mechanical systems by itself. Nearly all the cars, except some sport cars and heavy load carrying vehicles, started to be produced with this method after the 1980's because it is more suitable and economical for mass production. But, because of the inflexibility of the body and chassis, making an adaptation to original chassis is impossible.

The main differentiation between the cars is determined by the arrangement of the powertrain system and the mechanical parts. For example, the power-train systems can be categorized into three different groups which are front wheel drive, rear wheel drive and four wheel drive systems. The parts which form the different power-train systems are very similar, however the arrangements of these parts is factor that differentiates these systems.

The design of the new chassis should be flexible in terms of being simply adaptable to different type of powertrain systems or different size engines. This will allow any type or brand of vehicle used as a taxis to be enable conversion.

5.2.2- Analysis of the Current Brands

The car manufacturing brands which are the most economic with the cheapest service parts are mostly preferred among the taxi owners under economic conditions. As mentioned before, these economic vehicles are not designed to be used as a taxi. Not only the chassis, but also the form of the body and the interior is not suitable for the terms and conditions of the taxis. Also the parts are very likely to fray, decay and in the end, able to rot very easily because of their non-suitable designs, so it is not satisfactory enough to provide the comfort and the easy maintenance that the customer or driver expects under these circumstances.

In Turkey, taxi associations prefer using mostly the Italian designed and Turkish production car named Şahin which is produced by the company Tofaş. The preference of the Tofaş Şahin over other brands is due to its low selling price, easy maintenance and cheap repair parts. Although having these advantages, the vehicle is definitely not suitable for usage as a taxi like the other family sedan cars because of their small passenger spaces and many other unsuitable conditions.



Figure 51: Common Use of Doğan as Taxi in Turkey

5.2.3-Types and the Availability of Mechanical Parts

In designing a new frame and body, reusing of the parts like engine, power-train group, transmission, suspension system and other mechanic systems can be an economical solution for the owner of the car.

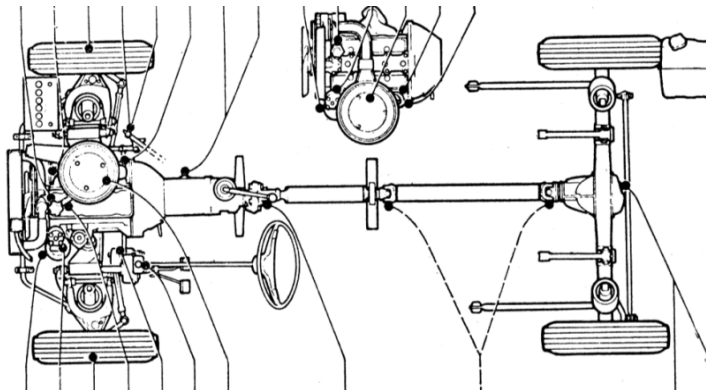

Figure 52: Technical Drawings of the Tofaş Şahin (Can, 1982).

This approach will also prevent many vehicles from being salvage since they are renewed and re-used. However the parts must be analyzed in detail. The most important point is the availability of these parts in the market. Parts should still be kept under production in order to provide service maintenance for the owners.

CHAPTER VI

DESIGNING THE NEW VEHICLE

6.1- Body Parts of the Vehicle

The time spend for while waiting for the car to be repaired is an important issue. This can be achieved by using easily changeable self supporting external body parts. The body parts should be designed so that they can be mounted and demounted to the chassis of the car without any need to remove additional parts. This design approach takes the vehicle one step forward from the mass produced, currently used vehicles since, even in the smallest accidents that the mass produced vehicles come across could lead to long and costly repairing operations. For instance, if an insignificant low speed crash damages the front corner of the vehicle, approximately five or six different parts will require to be repaired or changed. This is due to the placement of the parts, which are positioned at the front of the car such as side mudguards, hood and headlights etc. All these parts are in relation with the corner which is the most likely area to be damaged in most accidents. The exterior design of the vehicle should be constructed in order to limit the damage so that only the bumper will require repair. This is achievable even without having to change the form of the initial design of the cars. However this could be a kind of market strategy to sell additional parts.

Observing the accidents taking place at daily bases one can propose some ideas for improvement to the designers. In figure 53, only one half of the car's front bumper is damaged. If this bumper was made up of a right side and a left side bumper, in other words in two separate parts, then it will enable the replacement of only the damaged side and this will theoretically reduce the price by %50.



Figure 53: Damaged Car (Only from One Side)

Additionally, if the parts are produced from flexible and elastic materials, where a variety of alternatives exist today, they endure without any damage from the small accidents that occur in the traffic. Also plastics can be preferred since they are lighter than the metal parts, and they last longer since they do not rust.

The important issue on using plastic body parts is related to the materials' chemical properties. The impact strength, ductility and dimensional stability of the plastic resin can provide important advantages in production and usage. Also using the proper molding method according to the size and the shape of the parts is another important issue for the durability and rigidity of the final product.

There are many different types of plastic materials available, which will serve for these purposes, all requiring different production techniques. While composites, namely polyester or epoxy resin that are used to bond the glass fibers together can

easily be laid on one sided mould. Shaping polyethylene material used for car bumpers or liquid containers requires more complicated molds. These molds must be heated. Number of production, complexity of form and size of the object are the criteria that direct choice of the means of production.

6.2- Chassis of the Vehicle

In order to find the appropriate chassis type or to be able to develop the existing types for the project, the chassis types which have been used and are still being used throughout the history of automobile industry should be examined.

6.2.1- Examination of the Chassis Types

Throughout the development of motor vehicles, many different types of chassis have been developed and many improvements have been made in chassis technology. Some of the basic types of chassis which have been used or that are still being used are ladder chassis, tubular space frame chassis, unibody chassis and composite monocoque chassis. The basic features of these chassis can be described as follows;

Ladder Chassis

Major structure of ladder chassis is supported by central rails connected by cross braces. Ladder chassis was mostly used in vehicles of the 60s, and they are still being used in trucks and pick-ups due to good isolation between passenger cabin and road vibration (Car body design, 2005).



Figure 54: Ladder Chassis of Isuzu Pick-up

Tubular Space Frame

Tubular Space Frame is a very strong chassis construction technique often used in race cars and ultra high performance sports cars. The structure is formed from individual tubes, usually welded into a web of supports. This technique is actually cheaper to build for small production runs, since hand production is involved but it is not practical for mass production vehicles due to the fact that automated production is nearly impossible.

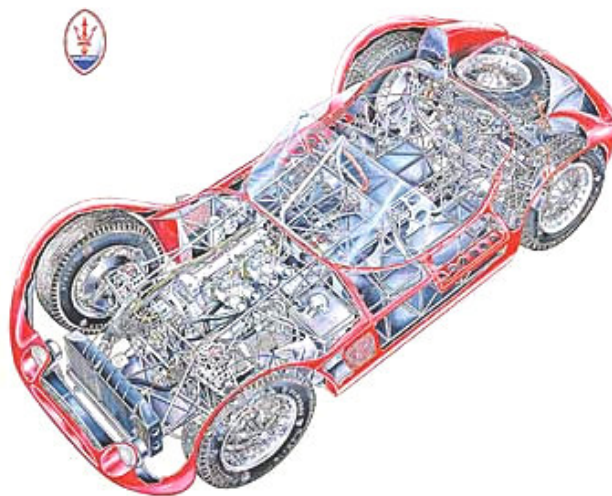

Figure 55: Maserati Tipo 61 Birdcage (1961) Cutaway Drawing

Unibody Chassis

This type of chassis is constructed of sheet metal pieces which are all spot welded together to form a metal box which makes up the structural and functional body of the car. Usually the metal used is steel, but some newer vehicles use aluminum to reduce the weight. They are generally heavier than a tubular space frame structure, but much safer. These types of chassis are usually more practical for large production vehicles, as automated production using robots is possible.

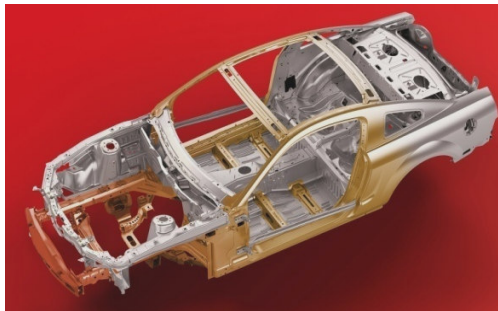

Figure 56: Unibody Chassis of Ford Mustang

Composite Monocoque Chassis

The lightest, most advanced performance vehicles employ this strategy for their chassis. It is similar to unibody in form, but integrates many different advanced materials, such as fiberglass, carbon fiber, Kevlar, or glass fiber reinforced polymer. These chassis are light, stiff, and expensive to produce.



Figure 57: Citroën Traction Avant (1934)

6.2.2- Deciding on the Appropriate Type for the Chassis

The usage of unibody and monocoque chassis to create the body causes the vehicle become more costly and harder to be repaired on any damage; therefore they cannot be considered for the project.

In the ladder chassis, first the body parts are put together to create the enclosed spaces and then they are attached to a chassis which holds everything together. But this chassis type is also not suitable for this project because the additional parts which are used to assemble the body parts together create extra weight and space loss for the vehicle.

Using tubular space frame technique for the chassis of the vehicle and developing it further to fit the desired purposes seems to be the most suitable approach for the project. These developments will mostly be concentrated on the form and details of various points and parts of the chassis.

The data gathered from the existing taxi documenting the Şahin's 3D body geometry, must be directly applied to the new chassis. This will make it possible to attach all the necessary technical parts transferred from Şahin to the new body. Next, the dimensional findings gathered during the design stage, must be carried to the chassis for making the final form to fulfill the requirements of a successful taxi. Then one more goal to be reached remains, which is composing the whole body of the

vehicle by easily replaceable but aesthetically non identifiable components. There should be no necessity for long hours to repair or change the parts in a repair shop.

Parts must be available with standard color schemes, and if the chassis is also affected by the damage, there should be several available solutions to repair or change that part of the frame.

On the other hand, these body parts are proposed to have a finished surface at the external surface and contain the details for fixing the inner surface linings at the interior. Sliding door as the passenger door is also produced in a similar manner and material, together with the driver's door and all windows.

One suggestion for this issue was offered in 1978. The Fiat Company tried to develop a new production method for one of their compact car which is Fiat VSS. In this approach, steel chassis carries all the necessary equipment of the car by itself and plastic, self-supporting body parts are attached to that frame.

This provides a freedom in the design criteria in terms of high flexibility on external shape, production and assembly. By that way, it also decreases the repair time of the vehicles significantly.

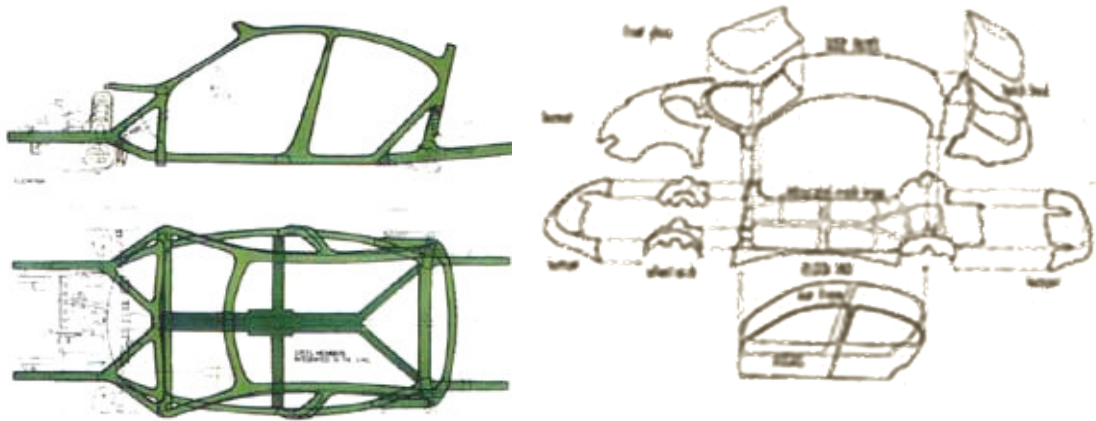

Figure 58: Fiat VSS Subsystems

6.3- Conceptual Sketches and Developments Proposed for the Project

6.3.1- Design Stages Followed in the Project

To be able to present as much different visual material and a detailed data as possible, building up a virtual model with computer based programs appears to be the fastest and accurate way. Working on a 3D virtual model makes it easier to understand the relations between the parts and also, it allows experimentation of the product with its users. Further the visual materials obtained in the computerized imaging programs provide a more realistic representation of the final model.

The first stage of the design should initiate by analyzing all the mechanical and body parts, which can be integrated to the new project. Then these parts will be modeled in computer based programs. With the help of the obtained data produced by the analysis of these parts, the limitations and development possibilities of the candidate vehicle will be figured. With the help of the virtual models the development of the design concept can be started.

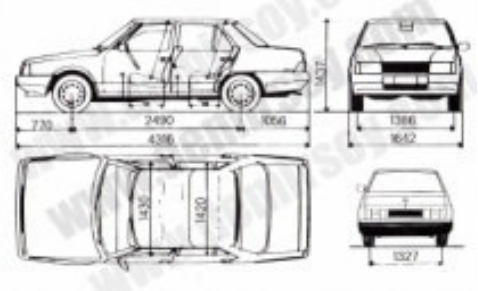

Figure 59: Analysis of the Mechanical Parts

While the initial sketches are being created for the design of the chassis and the body parts, the decision on the required spaces for both the users and the mechanical parts can be made. Afterwards the visual aspects and the aesthetic considerations of the form can be evaluated.

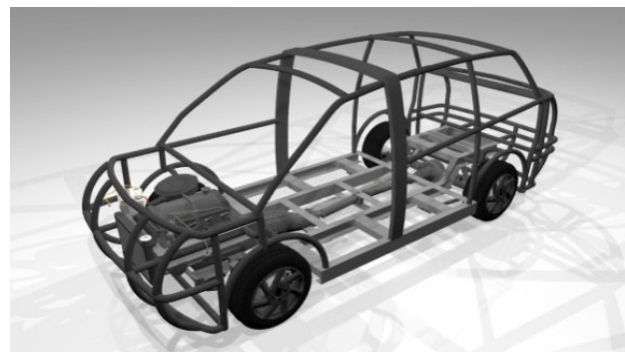
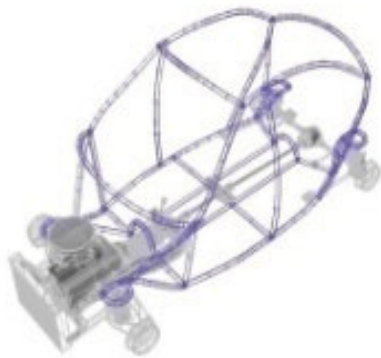

Figure 60: Designing the Chassis

As the form of the vehicle starts to emerge, details of the structural system and the issues of ergonomics, safety and security that are related to the users of the vehicle can be considered.

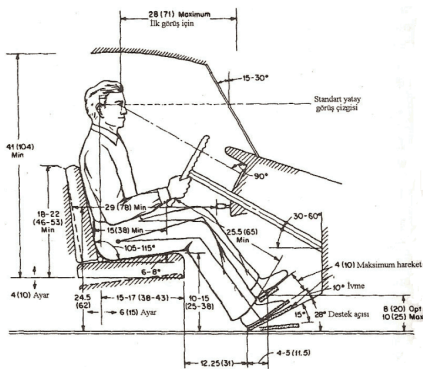
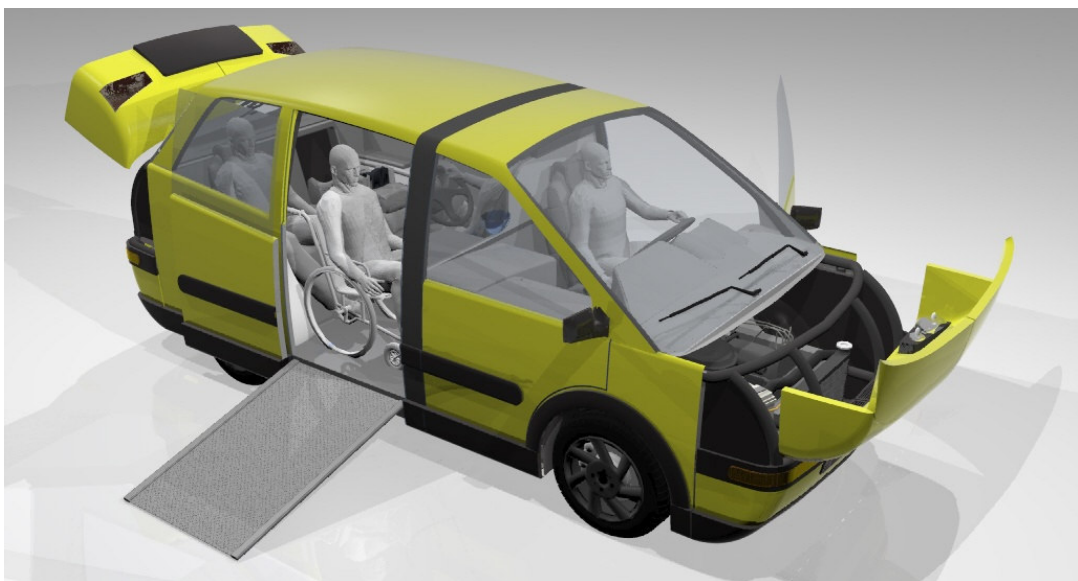

Figure 61: Designing the Form

Another design criterion to be considered at this stage should be the accessibility of the vehicle which involves the integration of the wheelchair ramp and the elaboration of how it will be used. Another question to be evaluated in order to be reflected on the design is deciding on the passenger capacity of the vehicle. It should also be noted that these passengers may be with luggage and the luggage capacity should be determined as well.



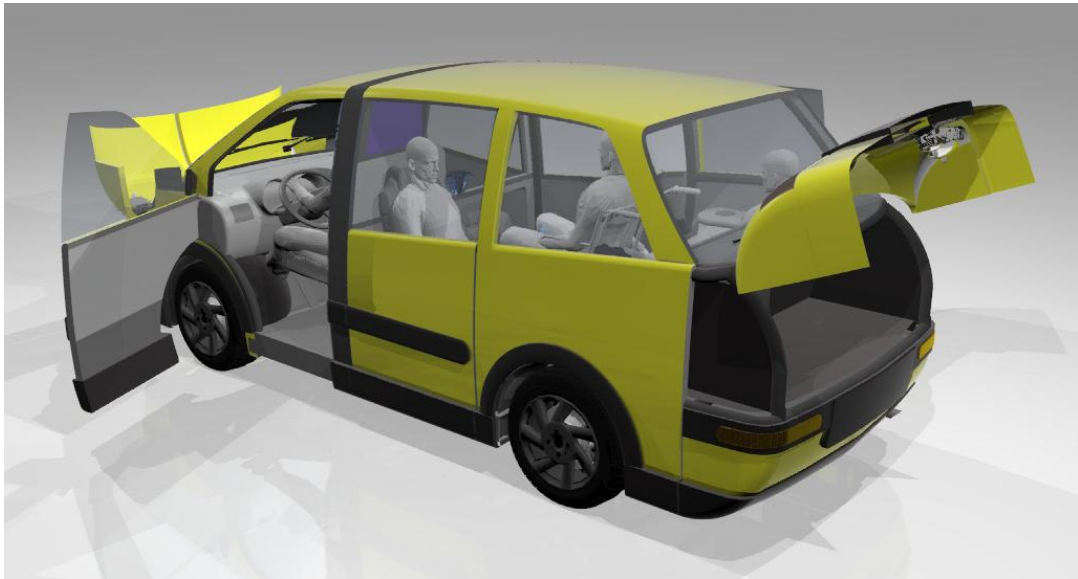

Figure 62: User and Design Interaction

6.3.2- Conversion of the Existing Vehicle



Figure 63: Disassembling the Parts

Mechanical parts such as engine, transmission, powertrain and suspension systems of the current vehicle are disassembled from the chassis. The remaining metal and plastic parts of the vehicle can be recycled in order to benefit from them as raw material.

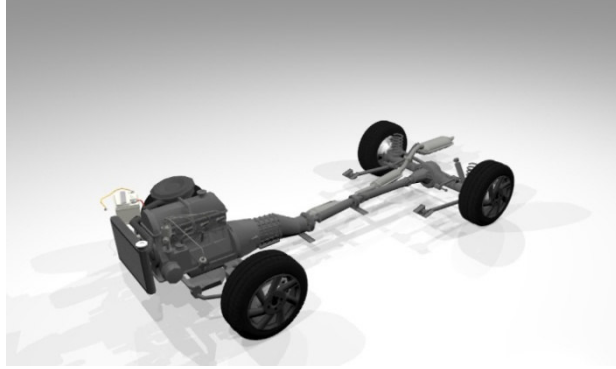

Figure 64: Mechanical Parts

The parts which have been disassembled from the vehicle are checked for any failure or damage. Necessary changes and repairs of the mechanical parts are made in this stage.

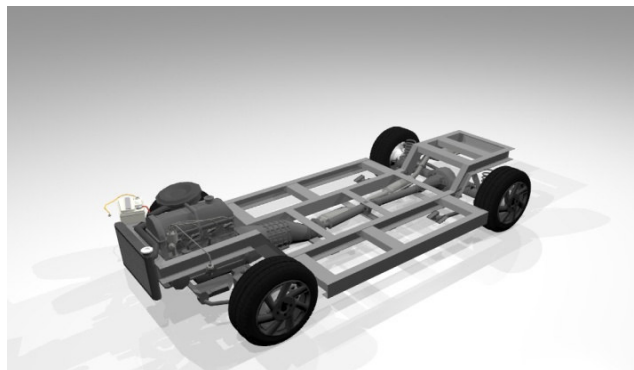

Figure 65: Base of the Chassis

After the restoration of the mechanical parts, they are reassembled on the new chassis. The base of the chassis where the mechanical parts are attached can be designed with a modular approach. This will provide the mechanical parts of different brands to be suitable for this chassis as well, which allows users to have a variety of choices in different brand's mechanical parts.

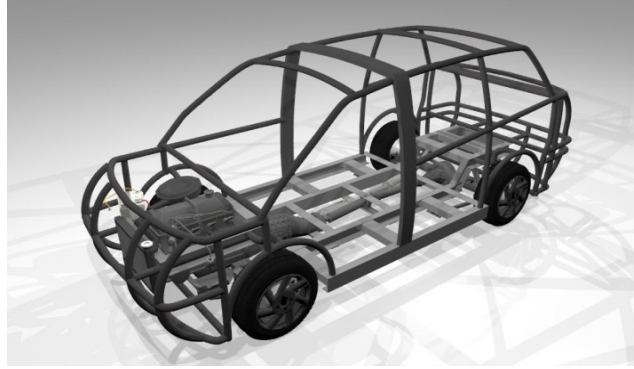

Figure 66: Chassis of the Vehicle

As the mechanical parts are being attached to the base of the chassis, the remaining parts of the chassis which will serve to support and carry the external body parts can be arranged. The attachment detail of these parts should allow easy demounting which will provide, in case of damage to the chassis, the ability to change and repair only the partial section of the structure. This will allow ease in maintenance and require less time.

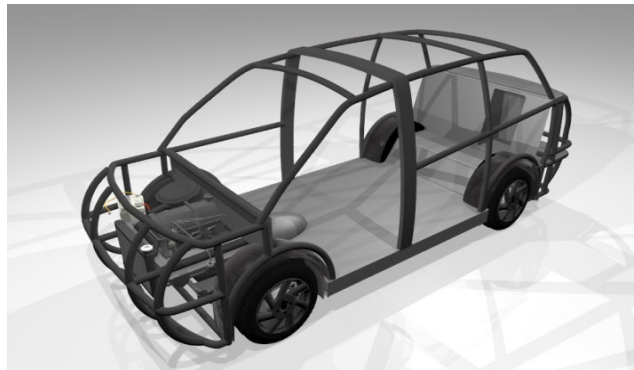

Figure 67: Installation of the Interior Parts

When the chassis is built up and the structure of the vehicle is constructed, the interior elements of the vehicle can be attached to the chassis. In this stage, first the plastic parts which separate the user space from the spaces which are left for the engine, mechanical parts and the luggage compartment are installed. The base parts

of these interior elements are fixed to the vehicle after the user ramp is attached to the chassis.



Figure 68: Installation of the Bulletproof Panel

The bulletproof panel which separates the driver spaces from the passenger space is attached to the vehicle after the floor of the vehicle is built. This panel also serves as a structural element of the vehicle.

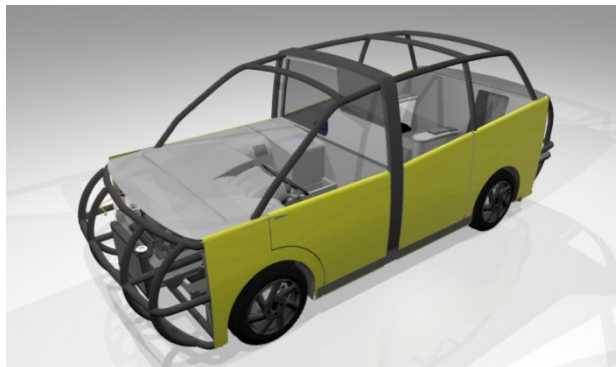

Figure 69: Installation of the Dashboard

After fixing the bullet proof panel to the vehicle, the next stage is attaching the parts related to driver's and passenger's compartment of the vehicle. Especially L-shape design dashboard, which creates the office of the driver is fixed to the vehicle and the tuning of the control units like the steering wheel, gear shift and the pedals of the vehicle is made. Also, the electrical wirings of the passenger

compartment for the information screen and lights are assembled. As the interior parts are mounted, the external body parts can be attached to the vehicle.



Figure 70: Installation of the Exterior Parts

The external and interior plastic parts work together in order to enclose the chassis of the vehicle and protect it from the external effects for preventing it from rusting. Then, the engine hood, tailboard, sliding passenger door and driver's door can be fixed to the vehicle.



Figure 71: Installation of the Roof Parts

After the installation of the parts which create the roof of the vehicle, the fine tuning of the external parts can be made and the protective plastic parts can be attached to the body of the vehicle.

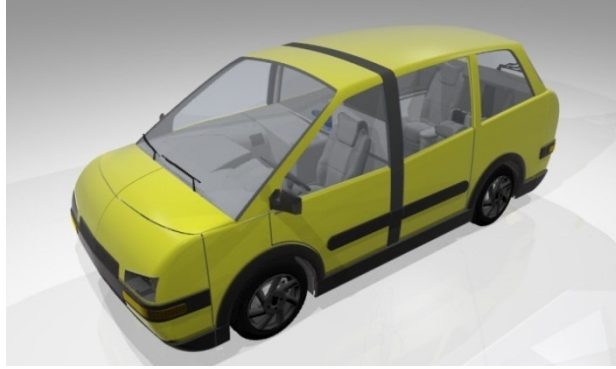

Figure 72: Installation of the Exterior Accessories

When the body of the vehicle is built, the interior parts like the seats, surface coverings and the exterior accessory parts such as headlights, backlights, side rearview mirrors, door knobs and windshields of the vehicle can be attached to the body.

6.3.3- Proposed Features of the Project

This section examines the new features which could be adapted to the project in order to enhance the travel quality for passengers and the driver.

Advantages for Owners

- Customization of vehicles
 - Ability to adapt different brands mechanical parts to the chassis
 - Optional devices, equipments and accessories
 - Bulletproof security panel



Figure 73: Driver's Office

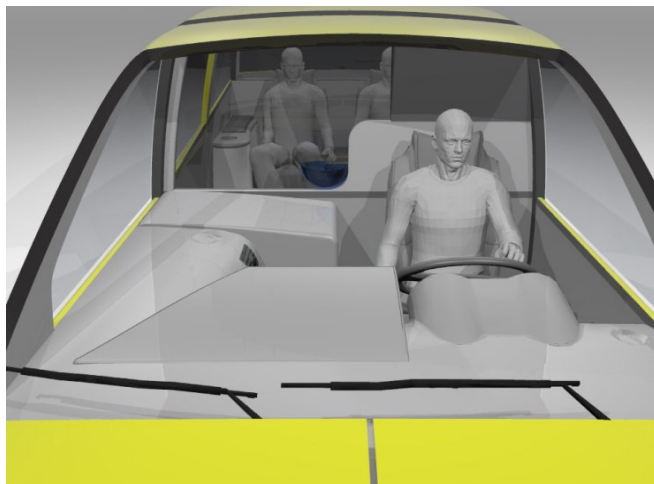

Figure 74: Bulletproof Security Panel

- Low-cost maintenance
- Naturally yellow colored plastic body parts
- Demountable galvanized metal chassis parts
- Easy to clean and high endurance materials in the passenger compartment

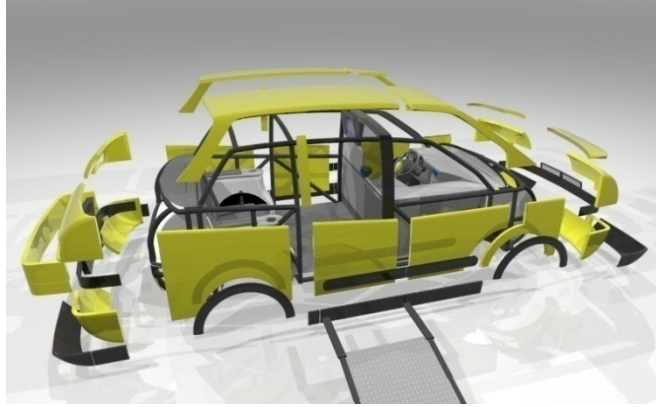

Figure 75: Exploded View of the Body Parts (1)

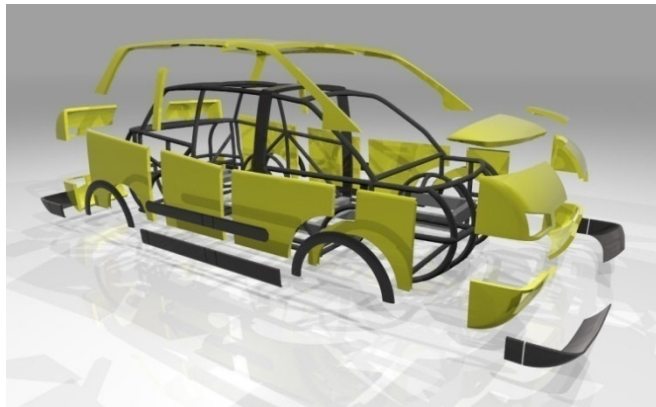

Figure 76: Exploded View of the Body Parts (2)

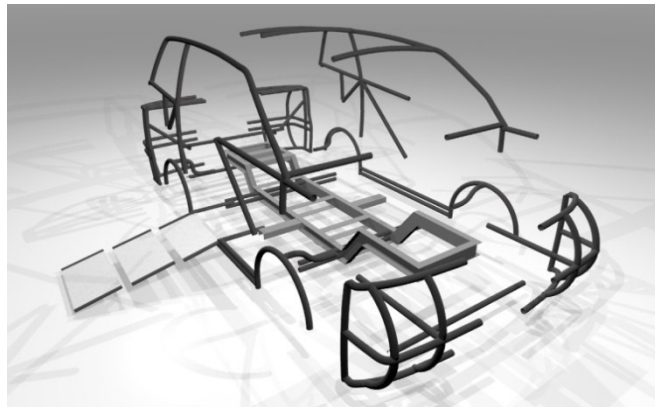

Figure 77: Demountable Chassis

Advantages for Passengers

-Comfortable compartment

-Non-slippery flat floor and 165 cm height roof

-95 cm width passenger sliding door frame opening

-Payment devices for credit cards



Figure 78: Passenger Compartment

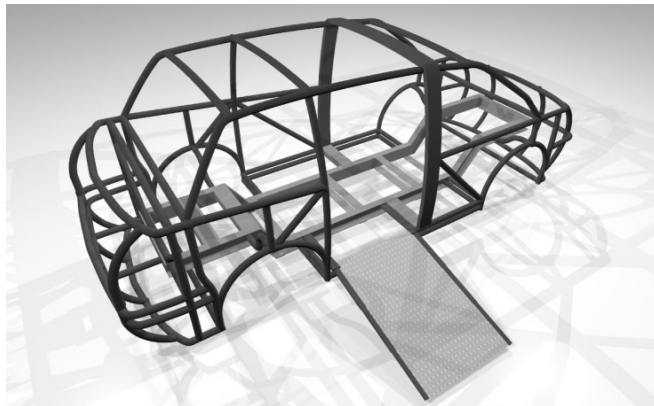

Figure 79: Door Frame



Figure 80: Passenger Compartment with Four Passengers

-Informative Devices

-Easy interface remote controlled information screen (optional)

-Displays the route and informs the total cost communicating with GPS system

-Displays the route and the information on the total cost communicating with GPS system

-Displays the daily news

-Information menu, displays the historical backgrounds of the major places that is on the route

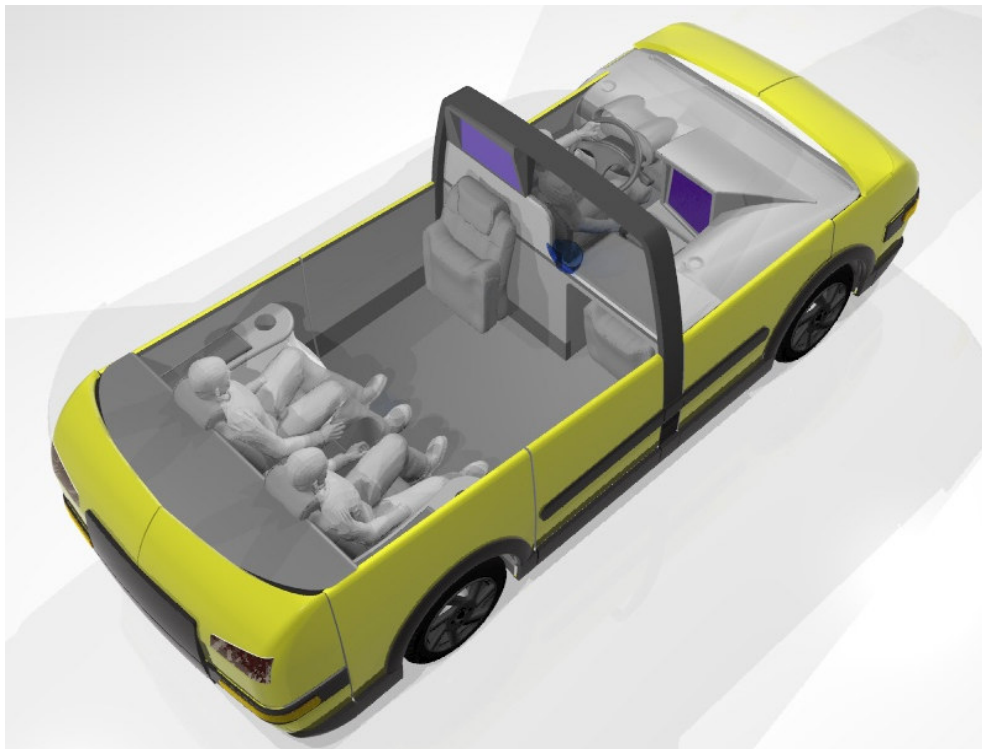

Figure 81: Passenger Compartment with Two Passengers

-Passenger Safety

-Seat belts for all users and lighting equipments

-Pre-fixed booster seat for child age up to 4 years old



**Figure 82: Seating Positions of Four Passengers
One of them is Child and One of Them is Disabled**

Advantages for the Disabled

- Easy entry and exit
- Non slippery 85 cm width access ramp
- Easily use pre-fixed wheelchair stabilizer clamps

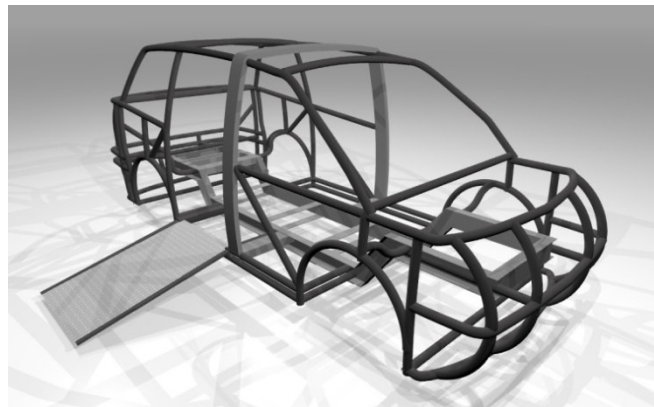

Figure 83: Access Ramp and Chassis

6.4- Evaluation of the Budget for the Realization of the Project

In the production of the vehicle, where different materials and labor is required, the determining factor in the budget analysis is the number of vehicles to be produced. A raise in the number of vehicles to be produced enables the utilization of

mass production techniques which will lead to a reduction in the material and labor costs. Therefore, an exact budget at this point cannot be estimated; however an analogy of the same type of parts and processes to be used may give a rough idea concerning the total budget.

6.4.1- Main body parts and material and detail proposals

Chassis of the Vehicle

The base of the vehicle is constructed by pre-formed and dye pressed 3 mm thick “U” and “L” profile metal sheet parts.

- The estimated amount of “U” profiles is approximately 12.0 linear meters.

- The estimated amount of “L” profiles is approximately 6.0 linear meters.

- The estimated amount of sheet metal required is approximately 4.0 square meters, which means that it is required to use 2.0 units of steel plates with thickness of 3 mm and 1000 mm x 2000 mm in size, with the total weight of 96.0 Kg.

Labor cost for producing an average sized “U” and “L” profiles is approximately 15.00 TL/Kg including the material cost.

- This will lead to a budget of approximately 150.00 TL for the production of the main frame of the vehicle.

The rest of the chassis is made up of tubular and steel profiles, with a diameter of Ø 34 mm with thickness of 2.5 mm, that are stamped, punched and re-formed as required for other parts to be bolted or welded.

- The estimated amount of tubular frame profiles is approximately 90.0 linear meters.
- Labor cost for producing average sized tubular profiles with some complicated forms and dents is estimated at approximately 18.00 TL/linear meter including the material cost.
- Stamping and opening connection ports and welding some flanges require some extra cost per unit linear meter. Since the shapes and sizes of these ports are not yet established, it has to be approximated that it will add 10.00 TL more per linear meter for the tubular materials.
- This will require a budget of approximately 2,500.00 TL for producing the tubular frame parts of the vehicle.

To prevent these metal parts from rusting, electro-galvanize coating with about 150 microns of thickness will be implemented on the outer surfaces. To protect the inner surfaces of the same material, series of functional holes and openings will be drilled and profiles are to be dipped in to some preventive solutions. This will require a budget of approximately 250.00 TL for the entire body frame with all the necessary provisions for attachments of bolted and welded parts. The budget for the scraps and the other crucial parts needed for the assembly of the chassis is estimated to be 300.00 TL.

The estimated total budget for the construction of the parts of the chassis and assembly of them costs nearly 3,200.00 TL with the raw material prices and labor charge taken from the dealers in the date of 10th of January 2009.

Body Parts

Polypropylene is assigned as the material for the shell of the body, which is currently very popular for the bumper parts, fuel and water containers, air filter covers and many other items used in modern vehicles. This material provides structural and economic advantages compared with many other plastics. The proposed manufacturing process is blow-molding. Since the mentioned method requires less energy during the form-giving process and simple and low technology molds can be utilized, it is considered to be appropriate for the main purpose of the project, which is to obtain the body parts as cheaply as possible.

The production of these pieces requires technological machinery. Therefore at this stage it is difficult to estimate a price for each of these body parts. So comparing the prices of the existing mass produced samples from the market, produced with similar material, size, shape and manufacturing methods can be useful for determining estimate values. With this concern, according to market research the budget required for the external and the internal polypropylene plastic parts is approximately 2,400.00 TL. A similar approach can also be used for estimating the budget for the windshields and other transparent parts where laminated glass is used. The total cost of these parts can be expected to be around 600.00 TL.

After overhauling the mechanical parts of the previous vehicle is accomplished, they will be transferred to the new vehicle. At this point the cost is estimated to be approximately 6,200.00 TL. Parts such as the seats, dashboard, dashboard equipment, display and gougues and other equipment used in the interior, costs about 1,200.00 TL. Some of these items may even be provided from the

previous vehicle. The external body parts such as the head and tail lights, the side mirrors, windshield wipers can be supplied for about 300.00 TL.

This concludes the estimation for the total price of the standard vehicle with no optional parts and this is 7,700.00 TL. The utilization of driver's and passenger's information systems with GPS module, manual operated wheel-chair ramp, second air conditioning system for the passenger compartment, such optional parts will increase the total cost for additional %15 and this will bring the total cost to about 9,000.00 TL.

Without knowing the total number of the vehicles to be converted, it is difficult to decide upon the production methods and select appropriate technologies to be used. The production number also directly affects the cost estimations and if the production number is acceptable, the total cost of the vehicle will decrease significantly.

Below are the first hand prices given for the recently popular vehicles used as taxis.

Fiat Palio Sole: 23,950.00 TL



Figure 84: Fiat Palio Sole

Hyundai Accent: 27,200.00 TL



Figure 85: Hyundai Accent

Dacia Logan: 17,600.00 TL



Figure 86: Dacia Logan

Fiat Doblo: 28,750.00 TL



Figure 87: Fiat Doblo

A comparison of the prices of these vehicles' with the cost of the vehicle to be obtained with the directives of this project, and especially assuming that the driver modifies his own Tofaş Şahin, there is a significant budget reduction in obtaining a new taxi. Furthermore, another important economical point is the easy and cheap maintenance. The economical advantages of the vehicle will also be revealed, even to a higher degree, during the long term use.

CHAPTER VII

CONCLUSION

“It may have four wheels and carry passengers, but the circumstances are totally different. A family car sits around much of the time, and when it goes somewhere, driver and passenger enter and leave together. A taxi moves all day, and exchanges passengers constantly. It stops, it starts, people enter, people exit, luggage comes in, and luggage goes out. During it all, the driver leftovers at the wheel, like a worker fix to his desk” (Goldberger, 2005)

This project tried to figure out economical solutions to the owners of the current taxi vehicles and the users of the taxi system in order to bring higher standards for a more comfortable and safer journey. Current vehicles are not satisfactory in terms of providing adequate comfort and safety because their design is not suitable for usage as a taxi. In this paper these differences are highlighted in order to create a more sufficient approach to the taxi design. Besides trying to increase the comfort, safety and functionality of the taxis, they are tried to be accomplished economically. Ease of the reuse of the mechanical parts of the existing taxis offers additional economic gains for owners or drivers of the vehicles. On the one hand, less repair time and less repair cost will be beneficial for the owners and the drivers; on the other hand, standardization of all the vehicles will bring more civilized and modern appearance to the cities. Developing a new taxi involves

significant value in terms of social developments. Taxi plays a significant role in changing the face of a city and has important implications to show development level of the city. The utilities provided for the passengers and the users offer ease in daily lives and more significantly further safety.

The examination of the taxi concept throughout history and its developments provided the consideration of previous challenges, that the taxi design has faced, and enabled the new design to account for these obstacles. On the other hand, the examination of the drivers and passengers expectations of taxi is analyzed in order to create satisfactory solutions.

Another area that is evaluated in this study is the reflection of the contemporary design understanding in the project. Therefore the current design approaches and criteria were examined as well as the conceptual studies for future developments were evaluated.

In the production section, manufacturing methods were examined in order to generate a plan for the design process. For the development of the taxi the technical methods were analyzed to chose the appropriate methods of production, materials and provide design decisions. In the evaluation of these areas the advantages that will be offered to the users became the determining factor.

In this study, the budget required for the production of the taxi was a significant concern. Therefore a research on the market prices was held to arrive to an approximate budget, which is then compared to the first hand selling prices of the vehicles currently used as taxis.

This thesis, also, approaches the concept of a new taxi to be easily adaptable to the system in terms of maintenance and service. This idea provides another economical solution, since the service and maintenance sector will remain the same with the qualified technicians that are experienced in these vehicles. This will offer the owners advantages as a reduction in repair time and easy access to required vehicle parts.

The current taxis do not reflect the specific design requirements of the identity of the taxi. This is why they cannot meet the expectations of the passenger and the driver. The important point is that in most cases of design products, there is always a function specific design approach which does not exist in the case of the taxi. This project tries to highlight the importance of the taxi concept and shows that the required significance is not shown.

Another important point involves the regulations of the taxi system. It has been argued that the taxi possess a public character and plays crucial role in regional transport. However the taxi has both a public and private character. Private owners either individuals or fleets exert at least as much control over operations as the city does. This should mean that within certain guidelines, taxi owners decide what vehicles to buy, how they should be maintained, and to a large extent, how the system should operate. This is another area that the taxi system remains inadequate in terms of satisfying the individual and public needs. Appropriate regulations has to be imposed on bringing the taxi system in to a standard quality level is highly important. However, this should be accomplished through an understanding of the driver and passenger needs which are highlighted in this study.

In this thesis a plan is proposed on how the modification of current taxis can be accomplished. However, for the realization of this project further analysis and test have to be involved. For instance, in order to provide the safety measures, a professional analysis of the structural endurance has to be made. Also physical and computer simulated crash tests has to be carried out to ensure that the required safety measures are accomplished.

The realization stages of this project also involves certain approvals from the governmental organizations. This vehicle will be classified as a custom production and it will require different registration procedures. In order to obtain these permits the vehicle has to pass the safety requirement tests. After obtaining the required permits the transformation of the vehicles can be carried out in stations developed in different areas of Turkey to provide the modifications. These stations have to be supervised in order to control that the changes are made according to the permitted project. Also these stations have to be supplied with additional service parts and technical knowledge.

The concerns that are discussed in this thesis are mostly related to highlighting the importance of the taxi and the requirements for specific design understanding which handles the user expectations in an economical way. However, as stated above there are further areas of concern for the realization of this project.

REFERENCES

Illustrations:

Archibald, D. (2002) *Traffic* [painting]. Private Collection

Bibliography:

Archer, O. (1994) **The World as Design**. Berlin, Ernst & Sohn.

Can, H. (1982) **Murat 124 / 131**. 2nd ed. İstanbul, İnkılap ve Aka Kitabevleri.

Cullen, C and haller, H. (2004) **Design Secrets: Products 2**. China, Rockport Publishers.

Farley, R. (1999) **Defensive Driving, Being a Cabbie is one of the Most Dangerous Jobs in America**, Dallas Observer.

Fenton, J. (1996) **Handbook of Vehicle Design Analysis**. London, MEP.

Canning et al. (2005) A Taxi is not a Car. In: Canning, Gorton & Marton **Designing the Taxi: Rethinking New York City's Moveable Public Space**. New York, Pentagram.

Heskett, J. (2004) **Industrial Design**. Singapore, Thames&Hudson.

Implementation of the New Booster Seat Law. [2006] (Wisconsin Act 106)

Noblet, J. (1993) **Industrial Design, Reflection of a Century**. Paris, Miroir du Siecle.

Lai, H. (2000) **The Ergonomic Research And Design Evaluation Of Child Car Safety Seating Device**. Ph. D. thesis, National Cheng kung University.

Munroe, B. (2005) **Century of London Motor Cabs**. London, Crowood Press.

National Highway Traffic Safety Administration (1996) **Traffic Safety Facts**. Washington, DC., US Department of Transportation.

Roozenburg, N. and Eekels, J. (1995) **Product Design: Fundamentals and Methods**, England, Chichester.

Schaller, Bruce (2005) **The Taxi Vehicle in the Ideal Taxi System**. Design Trust for Public Space, Designing the Taxi, November 2005.

Tisato, P (1995) **Review of Taxi Services in Adelaide for People with Disabilities**, a report to the Hon. Minister for Transport University of Adelaide: South Australian Centre for Economic Studies, January

Tumminelli, P. (2006) **Car design**. Italy, teNeues.

Internet Sources:

Car Body Design. (2006) **Car Body Design** [Internet]. Available from: <<http://www.carbodydesign.com>> [Accessed 15 January 2007].

Car Body Design (2005) **History of Automobile Body and Chassis** [Internet]. Available from: <<http://www.carbodydesign.com/articles/2005-04-13-chassis-history/2005-04-13-chassis-history.php>> [Accessed 15 November 2007].

Car Design News. (2005) **Car Design News, the Leading Online Resource for Automobile Design** [Internet]. Available from: <http://www.cardesignnews.com/site/home_/> [Accessed 02 January 2007].

Chan, S. (2005) **Designing a New Taxicab (But Keeping It Yellow)** [Internet]. Available from: <<http://www.nytimes.com/2005/06/11/nyregion/11taxi.html?ex=1276142400&%20en=48d095c954cde3d7&%20ei=5090&%20partner=rssuserland&%20emc=rss>> [Accessed 20 January 2007].

City Cab (2006) **City Cab** [Internet]. Available from: <<http://www.citycab.stadia.fi/www/en/index.php>> [Accessed 20 January 2007].

Dimmock, S. (2005) **London Taxi History 2005** [Internet]. Available from: <<http://www.lvta.co.uk/history.htm>> [Accessed 15 November 2007].

Harrell, D. (2006) **Prototype Taxi Gets Rave Reviews** [Internet]. Available from: <http://seattlepi.nwsourc.com/business/285743_taxi20.html> [Accessed 15 January 2007].

Jalopnik (2006) **Form Follows Function: A New Standard Taxi?** [Internet]. Available from: <<http://jalopnik.com/cars/news/form-follows-function-a-new-standard-taxi-202304.php>> [Accessed 20 January 2007].

Patton, P. (2007) **Ten Car Design Trends to Shape the Future, Automakers Turning to Designers to Make Their Models Stand Out** [Internet]. Available from: <<http://www.msnbc.msn.com/id/19314962/> > [Accessed 15 November 2007].

Perman, S. (2005) **A Taxi for the Next Hundred Years** [Internet]. Available from: <http://www.businessweek.com/innovate/content/oct2005/id20051028_344304.htm> [Accessed 20 January 2007].

Saltz, I. (2005) **Building a Better Taxi** [Internet]. Available from: <<http://www.stepinsidedesign.com/STEPMagazine/Article/28517/0/page/1>> [Accessed 18 January 2007].

Taxi-L World of Taxis (2006) **World of Taxis - Culture and History** [Internet]. Available from: <<http://taxi-world.home.att.net/culture.htm>> [Accessed 12 January 2007].

The Vehicle Production Group LLC (2006) **Standard Taxi** [Internet]. Available from: <<http://www.standardtaxi.com/>> [Accessed 15 January 2007].

Wikipedia Contributors (2006) **3D Computer Graphics** [Internet]. Wikipedia, the free Encyclopedia. Available from: <http://en.wikipedia.org/w/index.php?title=3D_computer_graphics&oldid=101153169> [Accessed 17 January 2007].

Wikipedia contributors (2009) **Hansom Cab** [Internet]. Wikipedia, The Free Encyclopedia. Available from: <http://en.wikipedia.org/w/index.php?title=Hansom_cab&oldid=266340397> [accessed 2 January 2009]

Wikipedia contributors (2009) **European Emission Standards** [Internet]. Wikipedia, Available from: <http://en.wikipedia.org/w/index.php?title=European_emission_standards&oldid=274388598> [accessed 17 February 2009]

Journal Articles:

Hürriyet. (2005) Şiddet Kurbanı Taksi Şoförleri. **Hürriyet** [Internet], September, 11. Available from: <<http://webarsiv.hurriyet.com.tr/2005/09/11/700089.asp>> [Accessed 28 October 2006].

Kaban, Ş. (2006) Özel Kabinli Taksiler için ÖTV Muafiyeti. **Türkiye** [Internet], September, 31. Available from: <<http://www.tumgazeteler.com/?a=1671724>> [Accessed 9 November 2007].

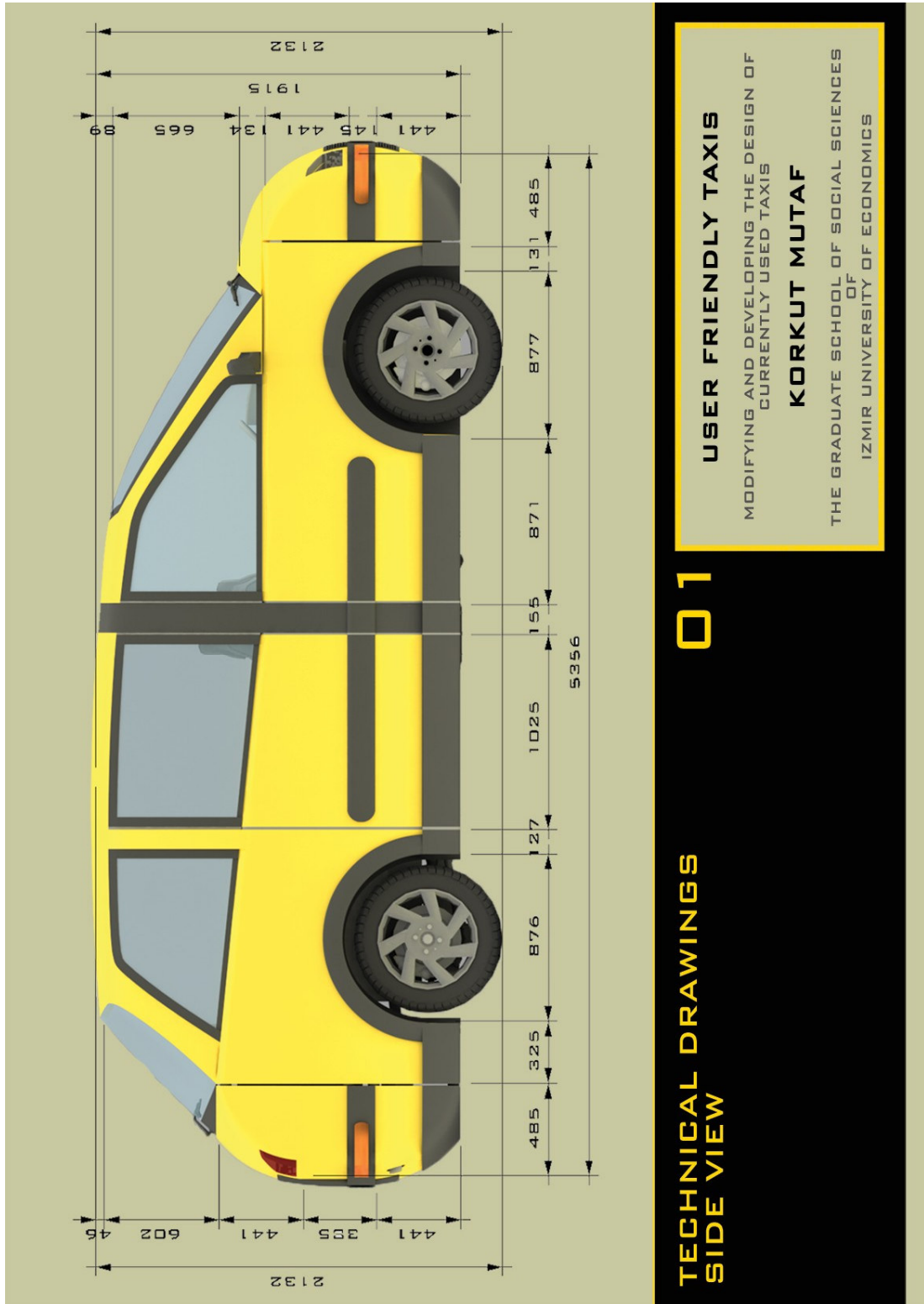

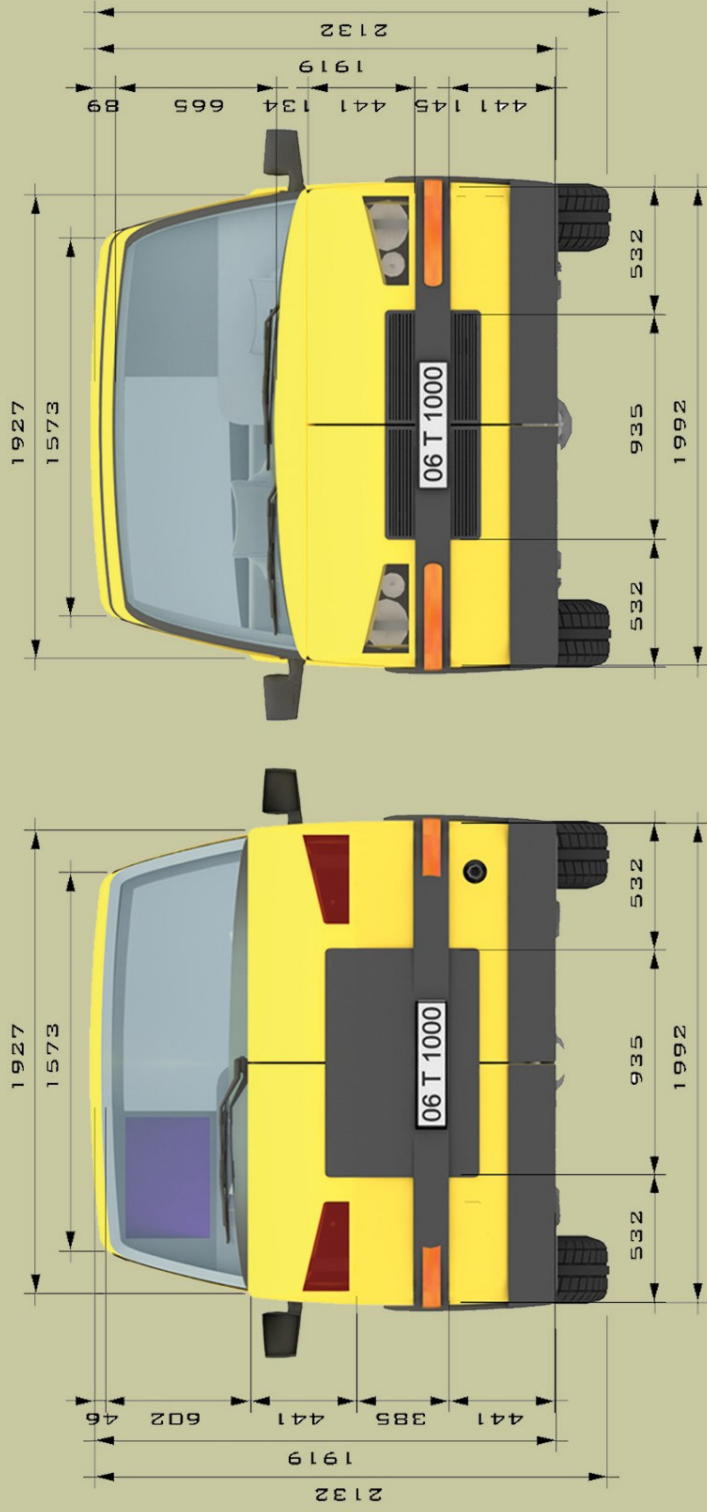

**TECHNICAL DRAWINGS
FRONT AND REAR VIEW**

02

USER FRIENDLY TAXIS

MODIFYING AND DEVELOPING THE DESIGN OF
CURRENTLY USED TAXIS

KORKUT MUTAF

THE GRADUATE SCHOOL OF SOCIAL SCIENCES
OF
IZMIR UNIVERSITY OF ECONOMICS

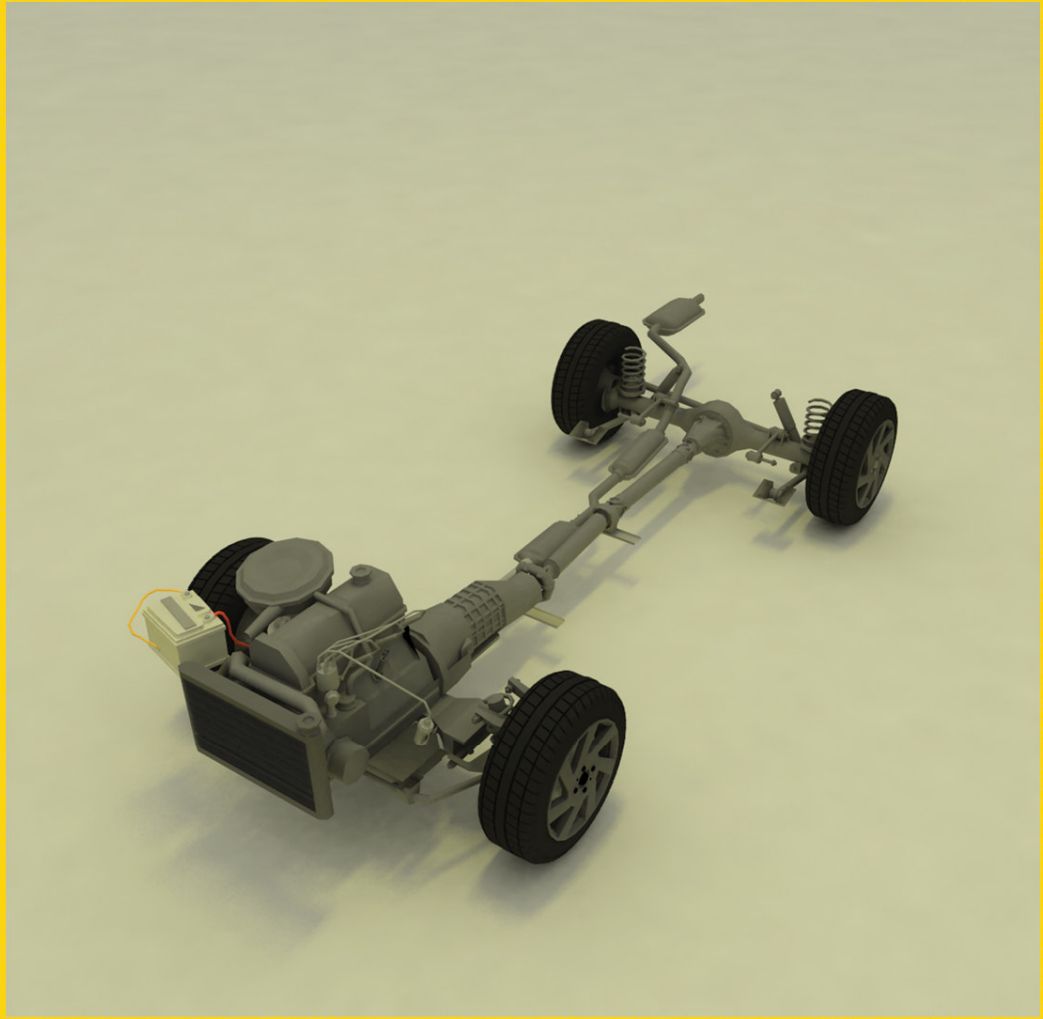

CONVERSION STAGES 01

MECHANICAL PARTS SUCH AS ENGINE, TRANSMISSION, POWER-TRAIN AND SUSPENSION SYSTEMS OF THE CURRENT VEHICLE ARE DISASSEMBLED FROM THE CHASSIS. THE REMAINING METAL AND PLASTIC PARTS OF THE VEHICLE CAN BE RECYCLED IN ORDER BENEFIT FROM THEM AS RAW MATERIAL.

USER FRIENDLY TAXIS

MODIFYING AND DEVELOPING THE DESIGN OF CURRENTLY USED TAXIS

KORKUT MUTAF

THE GRADUATE SCHOOL OF SOCIAL SCIENCES OF IZMIR UNIVERSITY OF ECONOMICS



CONVERSION STAGES 02

THE PARTS WHICH HAVE BEEN DISASSEMBLED FROM THE VEHICLE ARE CHECKED FOR ANY FAILURE OR DAMAGE. NECESSARY CHANGES AND REPAIRS OF THE MECHANICAL PARTS ARE MADE IN THIS STAGE. AFTER THE RESTORATION OF THE MECHANICAL PARTS, THEY ARE REASSEMBLED ON THE NEW CHASSIS.

USER FRIENDLY TAXIS

MODIFYING AND DEVELOPING THE DESIGN OF CURRENTLY USED TAXIS

KORKUT MUTAF

THE GRADUATE SCHOOL OF SOCIAL SCIENCES OF IZMIR UNIVERSITY OF ECONOMICS

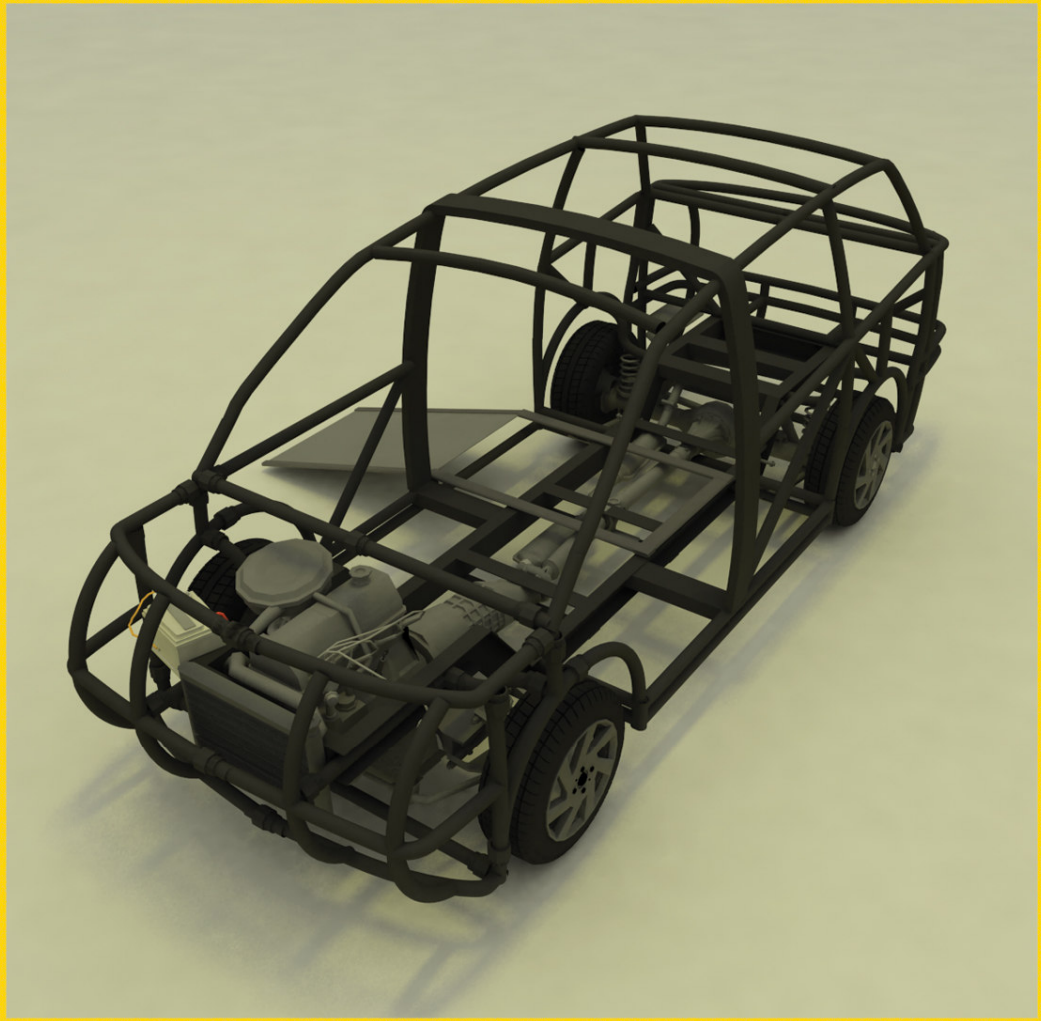

CONVERSION STAGES 03

AS THE MECHANICAL PARTS ARE BEING ATTACHED TO THE BASE OF THE CHASSIS, THE REMAINING PARTS OF THE CHASSIS WHICH WILL SERVE TO SUPPORT AND CARRY THE EXTERNAL BODY PARTS CAN BE ARRANGED.

USER FRIENDLY TAXIS

MODIFYING AND DEVELOPING THE DESIGN OF CURRENTLY USED TAXIS

KORKUT MUTAF

THE GRADUATE SCHOOL OF SOCIAL SCIENCES OF IZMIR UNIVERSITY OF ECONOMICS



CONVERSION STAGES 04

WHEN THE CHASSIS IS BUILT UP AND THE STRUCTURE OF THE VEHICLE IS CONSTRUCTED, THE INTERIOR AND EXTERIOR BODY ELEMENTS OF THE VEHICLE CAN BE ATTACHED TO THE CHASSIS.

USER FRIENDLY TAXIS

MODIFYING AND DEVELOPING THE DESIGN OF CURRENTLY USED TAXIS

KORKUT MUTAF

THE GRADUATE SCHOOL OF SOCIAL SCIENCES OF IZMIR UNIVERSITY OF ECONOMICS

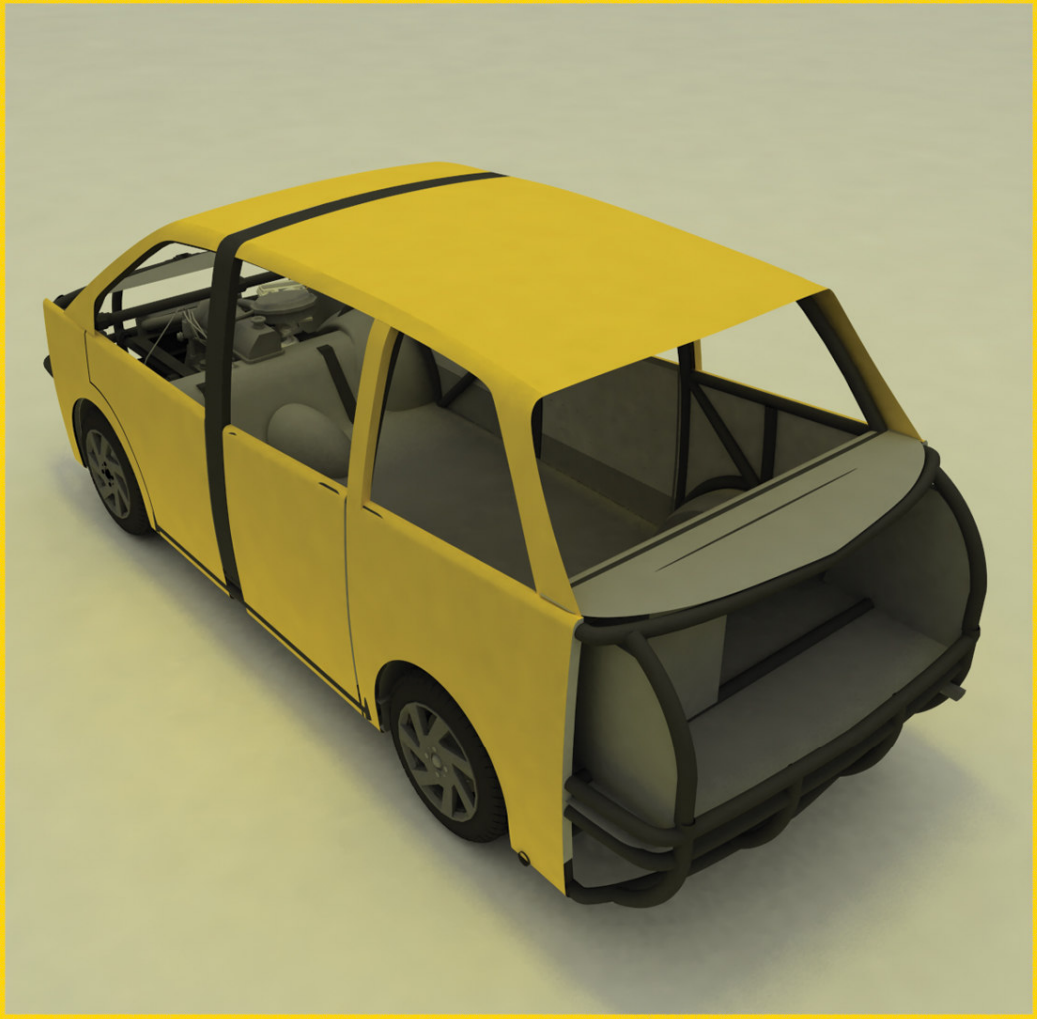

CONVERSION STAGES 05

THE EXTERNAL AND INTERIOR PLASTIC BODY PARTS WORK TOGETHER IN ORDER TO ENCLOSE THE CHASSIS OF THE VEHICLE AND PROTECT IT FROM THE EXTERNAL EFFECTS SUCH AS RUSTING.

USER FRIENDLY TAXIS

MODIFYING AND DEVELOPING THE DESIGN OF CURRENTLY USED TAXIS

KORKUT MUTAF

THE GRADUATE SCHOOL OF SOCIAL SCIENCES OF IZMIR UNIVERSITY OF ECONOMICS

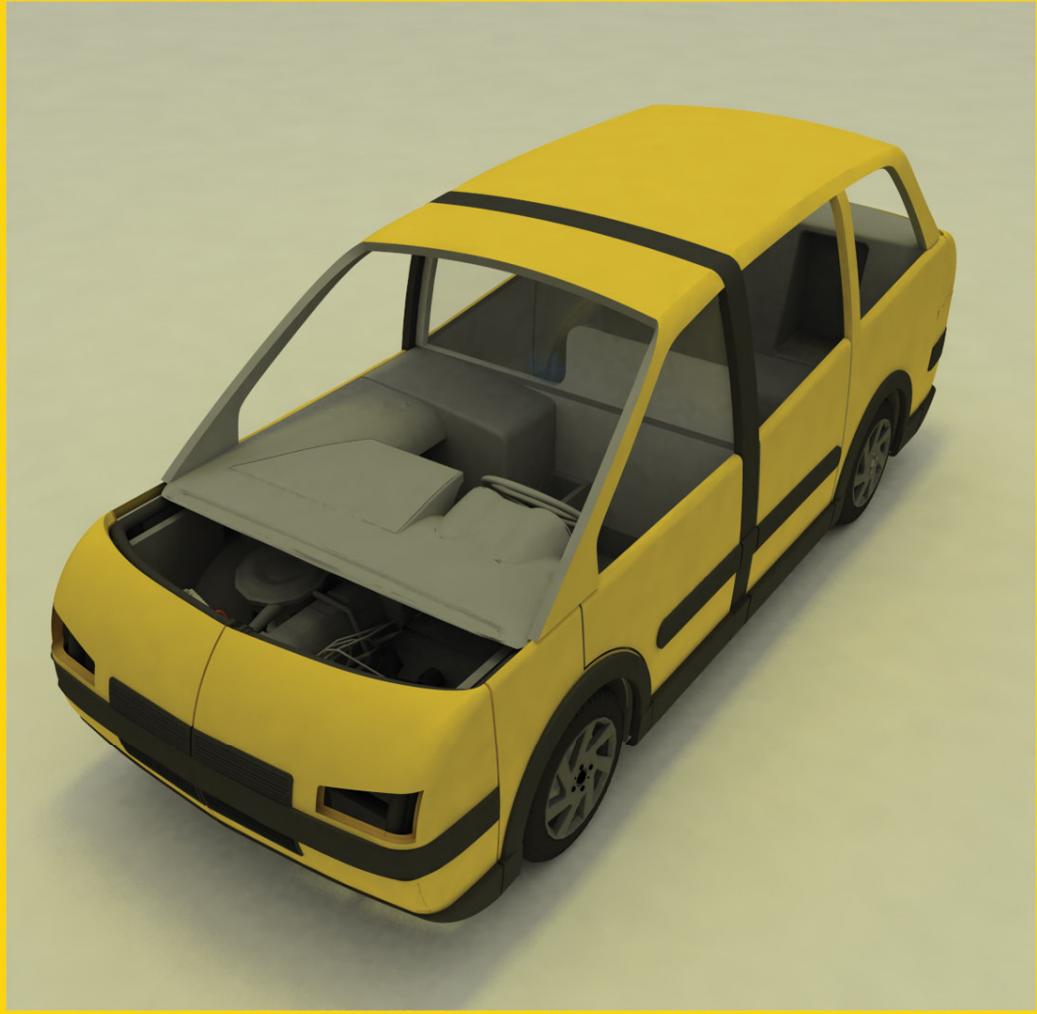

CONVERSION STAGES 06

THE BULLETPROOF PANEL WHICH SEPARATES THE DRIVER SPACES FROM THE PASSENGER SPACE IS ATTACHED TO THE VEHICLE AFTER THE FLOOR OF THE VEHICLE IS BUILT. THIS PANEL ALSO SERVES AS A STRUCTURAL ELEMENT OF THE VEHICLE.

USER FRIENDLY TAXIS

MODIFYING AND DEVELOPING THE DESIGN OF CURRENTLY USED TAXIS

KORKUT MUTAF

THE GRADUATE SCHOOL OF SOCIAL SCIENCES OF IZMIR UNIVERSITY OF ECONOMICS



CONVERSION STAGES 07

THE NEXT STAGE IS ATTACHING THE PARTS RELATED TO DRIVER AND PASSENGER COMPARTMENTS.

L-SHAPE DASHBOARD IS FIXED.

CONTROL UNITS SUCH AS STEERING WHEEL, GEAR SHIFT AND PEDALS ARE FIXED AND TUNED.

USER FRIENDLY TAXIS

MODIFYING AND DEVELOPING THE DESIGN OF CURRENTLY USED TAXIS

KORKUT MUTAF

THE GRADUATE SCHOOL OF SOCIAL SCIENCES OF IZMIR UNIVERSITY OF ECONOMICS



CONVERSION STAGES 08

THE INTERIOR ELEMENTS LIKE THE SEATS, SURFACE COVERINGS AND THE EXTERIOR ACCESSORY PARTS SUCH AS HEADLIGHTS, BACKLIGHTS, SIDE REARVIEW MIRRORS, DOOR KNOBS AND WINDSHIELDS OF THE VEHICLE CAN BE ATTACHED TO THE BODY.

USER FRIENDLY TAXIS

MODIFYING AND DEVELOPING THE DESIGN OF CURRENTLY USED TAXIS

KORKUT MUTAF

THE GRADUATE SCHOOL OF SOCIAL SCIENCES OF IZMIR UNIVERSITY OF ECONOMICS



SERVICE/MAINTENANCE 01

**RUST FREE AND YELLOW
COLORED EXTERNAL PLASTIC
BODY PARTS**

**HIGH ENDURANCE HEAVY-
DUTY MATERIAL USE**

**USER
FRIENDLY
TAXIS**

MODIFYING AND
DEVELOPING THE
DESIGN OF
CURRENTLY USED
TAXIS

**KORKUT
MUTAF**

THE GRADUATE
SCHOOL OF
SOCIAL SCIENCES
OF
IZMIR UNIVERSITY
OF ECONOMICS



SERVICE/MAINTENANCE 02

EASILY MAINTAINED HIGH
ENDURANCE ECONOMIC
STRUCTURAL PARTS

DEMOUNTABLE CHASSIS AND
BODY PARTS

USAGE OF SAME SHAPED
PARTS BOTH AT THE FRONT
AND REAR

USER FRIENDLY TAXIS

MODIFYING AND
DEVELOPING THE
DESIGN OF
CURRENTLY USED
TAXIS

**KORKUT
MUTAF**

THE GRADUATE
SCHOOL OF
SOCIAL SCIENCES
OF
IZMIR UNIVERSITY
OF ECONOMICS



SERVICE/MAINTENANCE 03

DEMOUNTABLE BODY PARTS

DEMOUNTABLE TUBULAR
SPACE FRAME CHASSIS
SUPPORTING BODY PARTS

LADDER TYPE BASE CHASSIS
CARRYING THE MECHANICAL
PARTS

USER FRIENDLY TAXIS

MODIFYING AND
DEVELOPING THE
DESIGN OF
CURRENTLY USED
TAXIS

**KORKUT
MUTAF**

THE GRADUATE
SCHOOL OF
SOCIAL SCIENCES
OF
IZMIR UNIVERSITY
OF ECONOMICS



SERVICE/MAINTENANCE 04

HEADLIGHTS AND TAILLIGHTS
MAINTAINED WITH
ECONOMICAL UNIVERSAL
LIGHTING ELEMENTS

SMALL ENGINE HOOD FOR
MINOR PERIODIC SERVICING

USER FRIENDLY TAXIS

MODIFYING AND
DEVELOPING THE
DESIGN OF
CURRENTLY USED
TAXIS

KORKUT MUTAF

THE GRADUATE
SCHOOL OF
SOCIAL SCIENCES
OF
IZMIR UNIVERSITY
OF ECONOMICS



USER INTERFACE

01

ADVANTAGES FOR PASSENGERS

- COMFORTABLE COMPARTMENT
- NON-SLIPPERY FLAT FLOOR /165 CM ROOF HEIGHT / 100 CM SLIDING PASSENGER DOOR FRAME OPENING / CREDIT CARD PAYMENT DEVICES / INFORMATIVE DEVICES / SEAT BELTS FOR ALL USERS AND LIGHTING EQUIPMENTS / PRE-FIXED BOOSTER SEAT FOR CHILDREN

USER FRIENDLY TAXIS

MODIFYING AND DEVELOPING THE DESIGN OF CURRENTLY USED TAXIS

KORKUT MUTAF

THE GRADUATE SCHOOL OF SOCIAL SCIENCES OF IZMIR UNIVERSITY



USER INTERFACE

02

ADVANTAGES FOR THE DISABLED

- EASY ENTRY AND EXIT
- 95 CM NON SLIPPERY ACCESS
RAMP WIDTH
- PRE-FIXED WHEELCHAIR
STABILIZER CLAMPS

USER FRIENDLY TAXIS

MODIFYING AND
DEVELOPING THE
DESIGN OF
CURRENTLY USED
TAXIS

**KORKUT
MUTAF**

THE GRADUATE
SCHOOL OF
SOCIAL SCIENCES
OF
IZMIR UNIVERSITY



USER INTERFACE

03

-FOUR PASSENGER CAPACITY

-400 LT. TRUNK CAPACITY

-ADDITIONAL HIDDEN STORAGE
AREA FOR THE DRIVER UNDER THE
LUGGAGE SPACE FOR THE SPARE
TIRE AND MAINTAINING EQUIPMENT

USER FRIENDLY TAXIS

MODIFYING AND
DEVELOPING THE
DESIGN OF
CURRENTLY USED
TAXIS

**KORKUT
MUTAF**

THE GRADUATE
SCHOOL OF
SOCIAL SCIENCES
OF
IZMIR UNIVERSITY



USER INTERFACE

04

DRIVER'S OFFICE

- L-SHAPED DASHBOARD
- EASILY ACCESSIBLE STORAGE SPACES
- CLEARLY READABLE INFORMATIVE SCREEN AND GAUGES
- SECURITY ELEMENTS

USER FRIENDLY TAXIS

MODIFYING AND DEVELOPING THE DESIGN OF CURRENTLY USED TAXIS

KORKUT MUTAF

THE GRADUATE SCHOOL OF SOCIAL SCIENCES OF IZMIR UNIVERSITY



USER INTERFACE

05

- OPTIONAL CUSTOMIZATION OF THE VEHICLE
- ADAPTABLE TO DIFFERENT BRANDS MECHANICAL PARTS
- OPTIONAL DEVICES, EQUIPMENTS AND ACCESSORIES
- BULLETPROOF SECURITY PANEL

USER FRIENDLY TAXIS

MODIFYING AND DEVELOPING THE DESIGN OF CURRENTLY USED TAXIS

KORKUT MUTAF

THE GRADUATE SCHOOL OF SOCIAL SCIENCES OF IZMIR UNIVERSITY



USER INTERFACE

06

- LOW-COST MAINTENANCE
- DEMOUNTABLE GALVANIZED METAL CHASSIS PARTS
- EASY CLEANED AND HIGH ENDURANCE MATERIALS IN THE PASSENGER COMPARTMENT

USER FRIENDLY TAXIS

MODIFYING AND DEVELOPING THE DESIGN OF CURRENTLY USED TAXIS

KORKUT MUTAF

THE GRADUATE SCHOOL OF SOCIAL SCIENCES OF IZMIR UNIVERSITY



ACCESS RAMP DETAILS 01

OCCUPIES MINIMUM SPACE
WHEN NOT IN USE

EASILY OPERATING
MECHANICAL STRUCTURE

HIDDEN UNDER FLOOR
SURFACE

NON-SLIPERY 150 CM X 95 CM
RAMP SURFACE

USER FRIENDLY TAXIS

MODIFYING AND
DEVELOPING THE
DESIGN OF
CURRENTLY USED
TAXIS

KORKUT MUTAF

THE GRADUATE
SCHOOL OF
SOCIAL SCIENCES
OF
IZMIR UNIVERSITY



ACCESS RAMP DETAILS 02

EASLY SLIDING PLATFORM OP-
ERATING ON TWO MAIN RAILS

RAMP SYSTEM IS ISOLATED
FROM EXTERIOR EFFECTS
WHEN PASSENGER DOOR IS
FULLY CLOSED

USER FRIENDLY TAXIS

MODIFYING AND
DEVELOPING THE
DESIGN OF
CURRENTLY USED
TAXIS

**KORKUT
MUTAF**

THE GRADUATE
SCHOOL OF
SOCIAL SCIENCES
OF
IZMIR UNIVERSITY

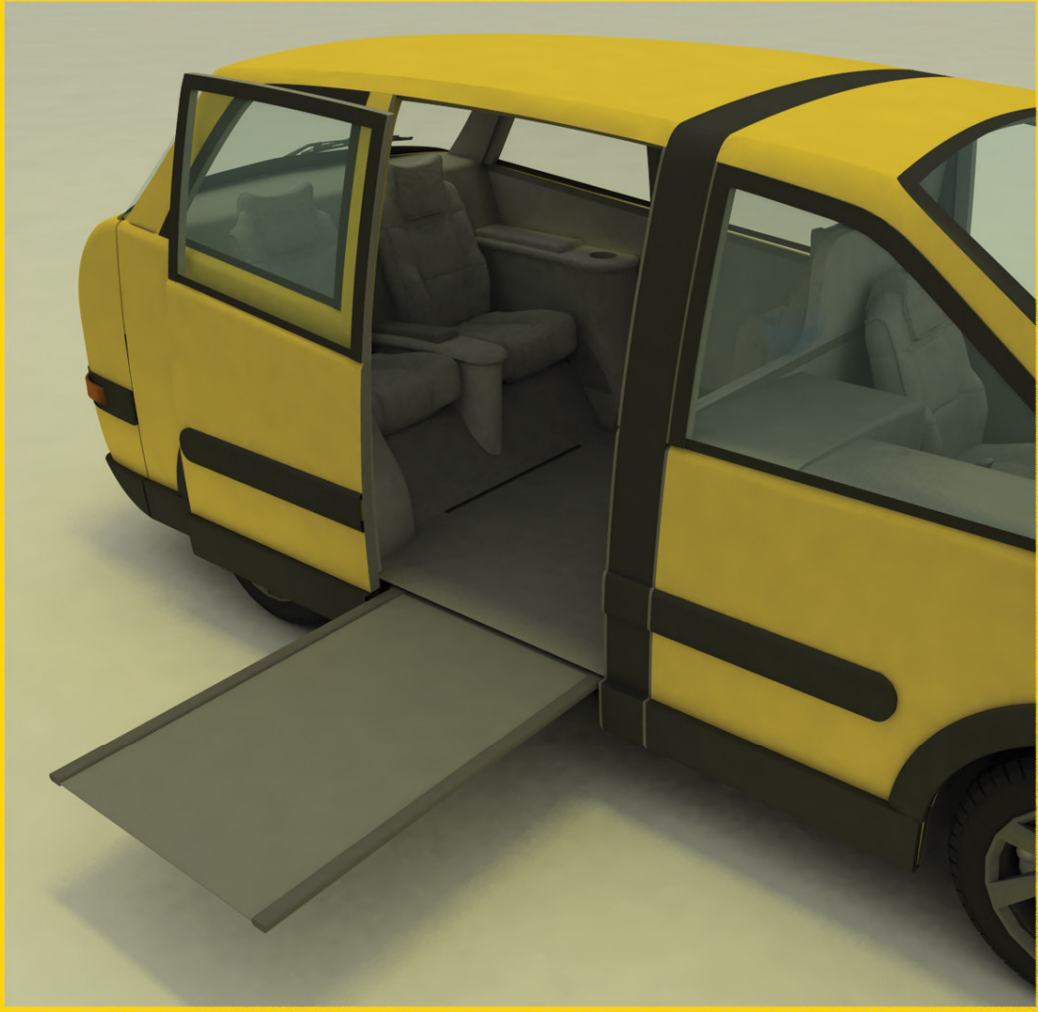

ACCESS RAMP DETAILS 03

**RAMP DOES NOT PENETRATE
IN TO THE PASSENGER SPACE
WHEN CLOSED**

**HEAVY-DUTY CHASSIS
MOUNTED RAMP STRUCTURE**

**UP TO 150 KG CARRYING
CAPACITY**

USER FRIENDLY TAXIS

MODIFYING AND
DEVELOPING THE
DESIGN OF
CURRENTLY USED
TAXIS

**KORKUT
MUTAF**

THE GRADUATE
SCHOOL OF
SOCIAL SCIENCES
OF
IZMIR UNIVERSITY

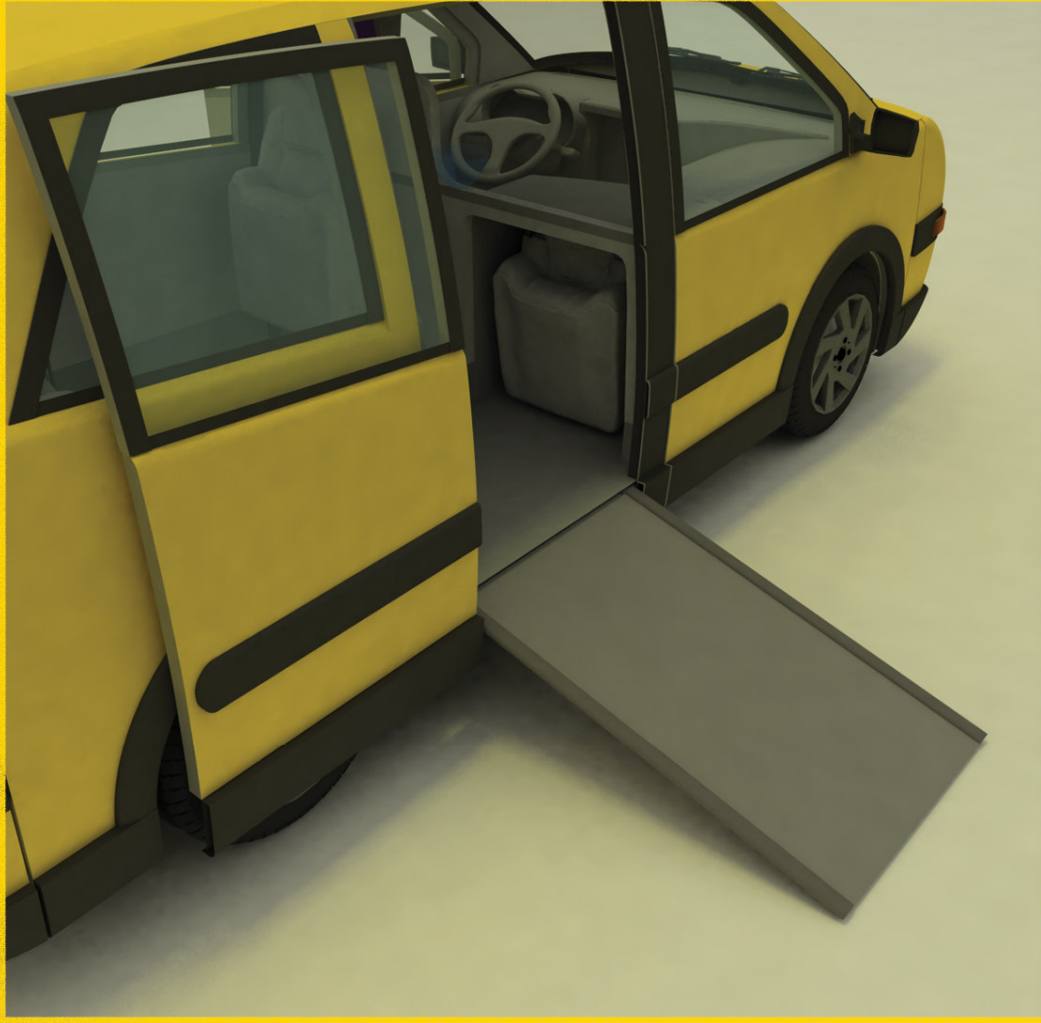

ACCESS RAMP DETAILS 04

ADJUSTABLE PLATFORM-
HEIGHT WHEN FULLY OPEN

NON-SLIPERY SURFACE AND
SIDE BARRIERS FOR
WHEELCHAIR

USER FRIENDLY TAXIS

MODIFYING AND
DEVELOPING THE
DESIGN OF
CURRENTLY USED
TAXIS

**KORKUT
MUTAF**

THE GRADUATE
SCHOOL OF
SOCIAL SCIENCES
OF
IZMIR UNIVERSITY