

DOKUZ EYLÜL UNIVERSITY
GRADUATE SCHOOL OF NATURAL AND APPLIED
SCIENCES

DESIGN AND CONTROL OF JI SILICONE
DISPENSER MACHINE

by
Serkan ÇAŞKA

June, 2011
İZMİR

DESIGN AND CONTROL OF JI SILICONE DISPENSER MACHINE

**A Thesis Submitted to the
Graduate School of Natural and Applied Sciences of Dokuz Eylül University
In Partial Fulfillment of the Requirements for the Degree of Master of Science
in Mechatronic Engineering, Mechatronic Engineering Program**

**by
Serkan ÇAŞKA**

**June, 2011
İZMİR**

M.Sc THESIS EXAMINATION RESULT FORM

We have read the thesis entitled “**DESIGN AND CONTROL OF JI SILICONE DISPENSER MACHINE** ” completed by **Serkan ÇAŞKA** under supervision of **Asst.Prof.Dr Güleser Kalaycı DEMİR** and we certify that in our opinion it is fully adequate, in scope and in quality, as a thesis for the degree of Master of Science.

Asst. Prof. Dr. Güleser Kalaycı DEMİR

Supervisor

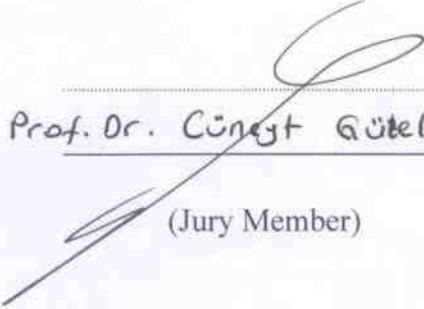
Prof. Dr. Cüneyt Gütelir
(Jury Member)

Asst. Prof. Dr. Ahmet Özkurt
(Jury Member)

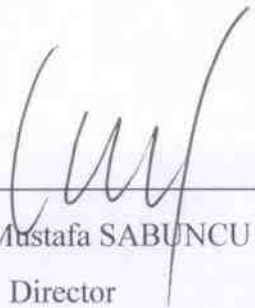
Prof. Dr. Mustafa SABUNCU
Director

Graduate School of Natural and Applied Sciences

ACKNOWLEDGEMENTS

I thank to my supervisor Asst. Prof. Dr. Gleser Kalaycı DEMİR for her different point view that she brought in my study and also thank to Prof. Dr. Erol UYAR for his support during my whole master education.

I thank to Vestel Dijital A.Ş. family especially to General Manager Hayrettin Çelikhisar and JI Bonding Unit Members for all financial, moral and technical supports.

Finally, I thank to my mother Fatma ÇAŞKA and my father Nevzat ÇAŞKA and my brother Murat ÇAŞKA who keep me coming to these days.

Serkan ÇAŞKA

ABSTRACT
DESIGN AND CONTROL OF JI SILICONE DISPENSER MACHINE

In this thesis, design and control processes of JI silicone dispenser machine that automatically executes the siliconizing operation on LCD modules that are the main vision equipment of LCD TV's, are studied.

The content of this study can be grouped into two main topics; namely, mechanical design and automation system design. In mechanical design processes, firstly 3D modeling of the developed machine was drawn and according to 3D modeling of the machine and specified criterions and methods, mechanical equipments such as linear mechanisms, rotational mechanism, support and connection equipments were selected. In parallel to this selection procedure, manufacturing of the auxiliary equipments were executed. Finally, by using the selected and manufactured equipments, mechanical construction of the developed machine was completed through the mechanical assembly process.

In automation system design, firstly the automation equipments such as HMI (operator panel), PLC, servo motor sets and sensors were selected. According to the device terminals, wiring project was drawn and connections of these equipments were done. Finally, the control devices were programmed with ASD soft (for servo drivers), WPL Soft (for PLC) and Screen Editor (for HMI) programs.

Keywords: Autonomous systems, Mechanical systems, PLC, Servo motors, JI process in LCD technique

ÖZ

JI SİLİKON SIKMA MAKİNESİNİN TASARIMI VE KONTROLÜ

Bu tez çalışmasında LCD TV üretiminin temel parçası olan LCD modüllerin JI sürecindeki silikonlama işlemini otomatik hale getiren JI silikon sıkma makinesinin tasarım ve kontrolü anlatılmaktadır.

Bu çalışmanın içeriği mekanik tasarım ve otomasyon sistemi tasarımı olarak iki ana başlık altında toplanabilir. Mekanik tasarım sürecinde, ilk olarak makinanın üç boyutlu modeli çizilmiştir ve makinanın üç boyutlu modeline ve belirli kıstaslar ve yöntemlere göre JI silikon sıkma makinesinde kullanılması uygun olan doğrusal mekanizmalar, döner mekanizma, destek ve bağlantı ekipmanları gibi mekanik ekipmanlar seçilmiştir. Seçim sürecine paralel olarak diğer yan ekipmanların üretimi gerçekleştirilmiştir. Sonuç olarak seçilen ve üretilen ekipmanlar kullanılarak mekanik montaj süreci ile makinanın mekanik yapısı tamamlanmıştır.

Otomasyon sistemi tasarımında, ilk olarak HMI, PLC, servo motor setleri ve sensörler gibi otomasyon ekipmanları seçilmiştir. Sonrasında cihaz terminalleri dikkate alınarak kablolama projesi çizilmiştir. Son olarak control cihazları ASD soft (servo motorlar için), WPL Soft (PLC için) and Screen Editor (HMI için) programları ile programlanmıştır.

Anahtar Sözcükler: Otomasyon Sistemleri, Mekanik sistemler, PLC, Servo motorlar, LCD tekniğinde JI süreci

CONTENTS

	Page
M.Sc THESIS EXAMINATION RESULT FORM.....	ii
ACKNOWLEDGEMENTS	iii
ABSTRACT.....	iv
ÖZ	v
CHAPTER ONE – INTRODUCTION	1
CHAPTER TWO – MECHANICAL DESIGN.....	10
2.1 3D Modeling Of The Developed Machine.....	11
2.2 Mechanical Hardware Selection.....	12
2.2.1 Linear Motion Mechanisms Selection.....	13
2.2.1.1 Main Carrier Mechanism Selection	16
2.2.1.2 XU Side Silicone Mechanism Selection	23
2.2.1.3 LCD Module Carrier Mechanism Selection	24
2.2.1.4 Vertical Motion Mechanism Selection	25
2.2.2 Rotational Motion Mechanism Selection.....	26
2.2.3 Mechanical Support Equipments Selection	27
2.2.3.1 Reducer Selection	27
2.2.3.2 Support Blocks Selection.....	31
2.2.4 Pneumatic Panel And Pneumatic Equipments Selection	31
2.3 Equipments Manufacturing	35
2.4 Mechanical Assembly	35
CHAPTER THREE – AUTOMATION SYSTEM DESIGN.....	40
3.1 Automation System Equipment Selection.....	41
3.1.1 Control Equipments Selection	41
3.1.1.1 Motor Selection.....	41

3.1.1.2 PLC Selection	50
3.1.1.3 Operator Panel Selection And Control Panel.....	53
3.1.2 Sensing Equipments Selection	55
3.2 Wiring Project and Connections.....	58
3.2.1 PLC Connections	61
3.2.2 Servo Driver Connections	63
3.3 Software.....	66
3.3.1 PLC Programming.....	66
3.3.1.1 Automatic program blocks on plc program	68
3.3.1.2 Serial communication blocks on plc program.....	85
3.3.2 Operator Panel Programming.....	89
3.3.3 Servo Driver Programming	95
3.3.3.1 Auto Tuning Function Settings.....	96
3.3.3.2 Motor Control Mode And Rotation Direction Settings	97
3.3.3.3 Acceleration And Deceleration Ramps Settings.....	99
3.3.3.4 Input And Output Terminal Settings Of CN1 Connector	100
3.3.3.5 Homing (Reference Operation) Mode Settings	102
3.3.3.6 Speed And Position Settings Of Internal Positions.....	103
3.3.3.7 Communication Settings.....	104
CHAPTER FOUR – OBSERVATIONS ABOUT THE PRODUCTS OF JI SILICONE DISPENSER MACHINE.....	108
CHAPTER FIVE – RESULTS AND SUGGESTIONS.....	112
REFERENCES.....	115
APPENDICES	121

CHAPTER ONE

INTRODUCTION

The humankind has started to use several tools in order to survive in the nature since its existence in the world. Then these tools have turned into simple mechanisms in the length of time. During this transformation process, by the change of the priorities in human life, human has started to use the mechanisms for several different purposes such as; to survive in the nature, to make the life conditions better, to make a job by using minimum manpower and minimum energy. At the 21th century this development process goes on with the advanced machines. (Söylemez, E, 2000).

Industrial automation that came to order in mechanization process of the world in recent years, minimizes the human factor in any action by the help of mechanisms or machines. Industrial automation consists of industrial control and industrial sensing equipments. At the present day, with new developments in industrial automation techniques, machine design and manufacturing has become easier and efficient. The two main concepts in manufacturing sector such as the quality and speed forced the companies to prefer the machines that were designed with industrial automation techniques. (Nitzan, D. & Rosen C.A., 1976).

By the new developments in industrial automation technologies, there have been important exchanges in both of industrial control and industrial sensing equipments. For example, the systems that are controlled by relays and by specific control circuits have generally many disadvantages, in terms of cost, complex structure and difficult fault determination so people tried to overcome these disadvantages with new techniques. Besides developments in automation techniques, with the accordance between hydraulic, pneumatic equipments and industrial automation techniques, industrial automation concept has become more acceptable in every production sector fields. (Hametner, R. & Zoitl, A. & Semo, M., 2010)

Industrial automation concept has gradually become effective in engineering fields. In the past, engineering was built on general branches which are indirectly related with industrial automation such as electric, electronic and mechanic but today there are some specific branches directly concern with industrial automation such as automation engineering, industrial design engineering, control engineering, mechatronic engineering. In these branches, system modeling and automatic control, robotic systems, kinematics, power electronic, embedded software, industrial control system design, industrial sensing, image processing, hydraulic, pneumatic, artificial neural networks, artificial brain etc. techniques are mainly investigated. Industrial automation systems that are based on these techniques, were developed in order to use in several basic industry branches such as defense, automotive, electronic household equipments. For example, in 2007, Syed Faiz Ahmed realized a successful study that contains to transform an injection molding machine with relay control panel into micro controller based control system (Ahmed, S. F., 2007). In 2003, Kay-Soon Low and Meng-Teck Keck developed a prototype precision linear stage that has a positioning accuracy of 1 micrometer and a maximum speed above 1 m/s. A permanent magnet dc linear motor was used in the system as the actuator to eliminate the need for mechanical transmission from the rotary to linear motion. In order to get a fast and accurate closed loop response, they developed a state space predictive controller and a dynamic friction compensation system for the precision stage. (Low, K. & Keck, M., 2003). Pla, F. et.al have developed a system about intensive fruit and vegetable sorting that is a common task in productive regions. The produce is classified according to quality levels that are related with maturity degree, weight, size, density, skin defects, etc., in order to meet the market standards. They mentioned that the most important of these tasks require the automatic visual inspection. A distributed and scalable system for sorting automation was consisted of a central control unit, a user interface and storage unit, a set of weight modules, a set of vision modules, a set of output control units. (Pla, F.& Sanchiz, J.M.& Sanchez, J.S. , 2001). Anwar et.al discussed Human Machine Interface (HMI) system and OLE for Process Control (OPC) and their roles, coordination and functionality in industrial automation technology.

They mentioned that HMI basically consists of the components that represent industrial devices e.g. motors, pumps, valves, and dampers etc. This study shows the place and the importance of HMI devices in an industrial automation system. (Anwar, M.R. & Anwar, O. & Shamim, S. F. & Zahid, A. A., 2004). Hanlon discussed several typical applications of AC drives in industrial automation. The specific applications are related to requirements for drive performance and features and also the capabilities of AC drivers such as changing the speed and torque according to process conditions. This study shows the advantages of the motor drivers in automation technology. (Hanlon, D. , 2002)

LCD TV manufacturing is one of the biggest sector in electronics and industrial automation is used in several applications in this field. The most important component is LCD in LCD TV manufacturing sector. In addition to LCD, there are some special components such as COF (chip on film) and PCB. A special system is used in order to bond electronic components such as LCD, COF, PCB to each other. This technique is generally called as “JI process” by LCD TV manufacturers. The purpose of this process can be summarized as bonding the hundreds of conductors placed on LCD, COF and PCB components within 20 micrometer sensibility. There is no doubt the manufacturing system that executes this process should consist of top level equipments and techniques. This system is called as “JI bonding line”. JI bonding line that is shown in Figure 1.1, generally has 13 units placed sequentially in a typical LCD module manufacturing factory.



Figure 1.1 JI bonding line

In JI bonding line, LCD's that are called as pure cell are given into the machine. Some operations about micro level bonding are executed on pure cells. After the bonding operations of PCB, LCD and COF, pure LCD becomes LCD module that has all the parts that it needs to show an image. LCD module is as shown in Figure 1.2.



Figure 1.2 An example view of LCD module

LCD modules are taken by process control members with esd (electrostatic discharge) protected clothes from unloader unit of JI bonding line. Although bonding quality of PCB, COF and LCD is checked by image processing techniques in JI bonding line, some mechanical tests should also be applied to modules. Image quality of modules is checked with test patterns and adhesion force of the components is checked with mechanical tests by process control members.

There are 6 operation steps that were executed by 4 process control members in manual test and siliconizing process. When an LCD module came to unloader unit of JI bonding line, as the first step, one of the test members goes to take LCD module from unloader unit and then brings LCD module to test tables as the second step. As the third step, test members apply visual and mechanical tests to LCD modules then as the fourth step, they place them to test-ok tables. As the fifth step, member that is responsible for manual siliconizing, brings them to the manual silicone machine and as the sixth step member executes manual siliconizing operation and place LCD module on siliconized LCD module table. These six process control operations are as shown in Figure 1.3.

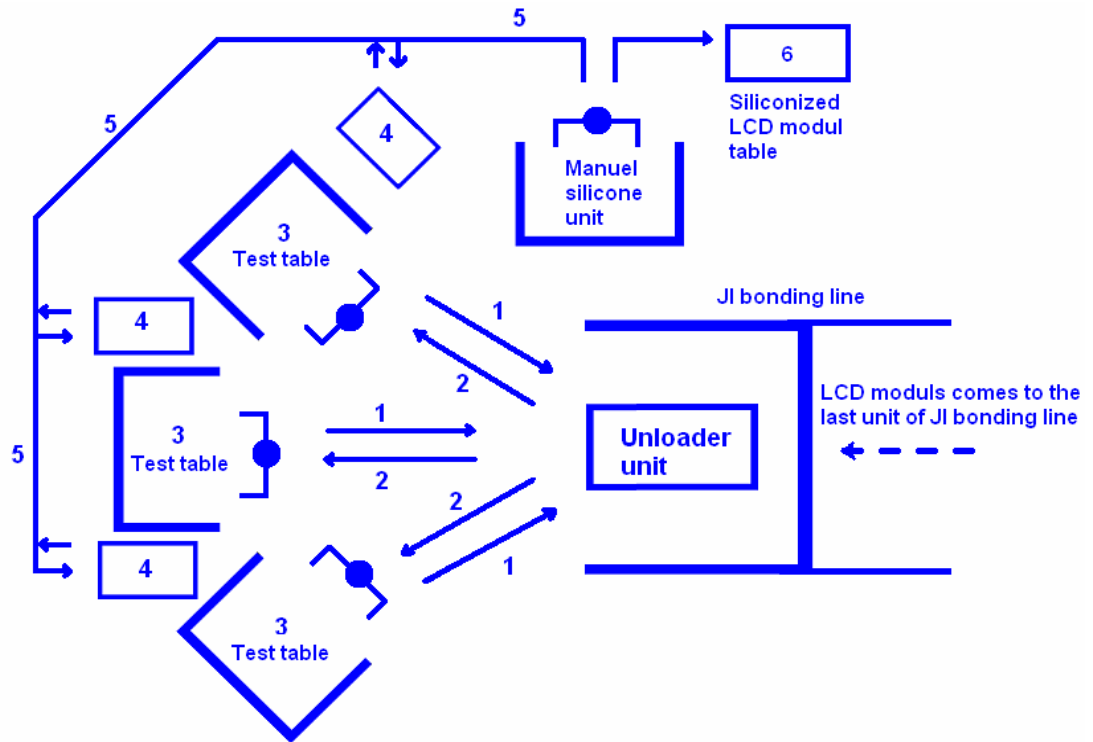

Figure 1.3 LCD module test and siliconizing processes

Manual silicone machine is used to siliconize the modules by using image processing technique with millimetric sensibility. Manual silicone dispenser machine is as shown in Figure 1.4.

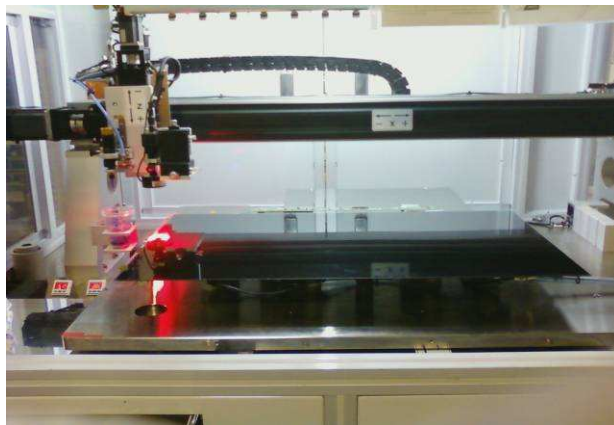

Figure 1.4 Manual silicone dispenser

There are two main reasons to siliconize LCD modules. One of them is to fill the gap between COF and LCD conductors. In this gap, LCD conductors are open to air influence, this situation can cause oxidations of LCD module conductors.

Silicone also called as “tuffy” prevents this oxidation and also possible problems that can appear on signal transmission. Second reason to siliconize LCD modules is to increase adhesion force between COF and LCD’s. LCD module with silicone and LCD module with no silicone are given in Figure 1.5.

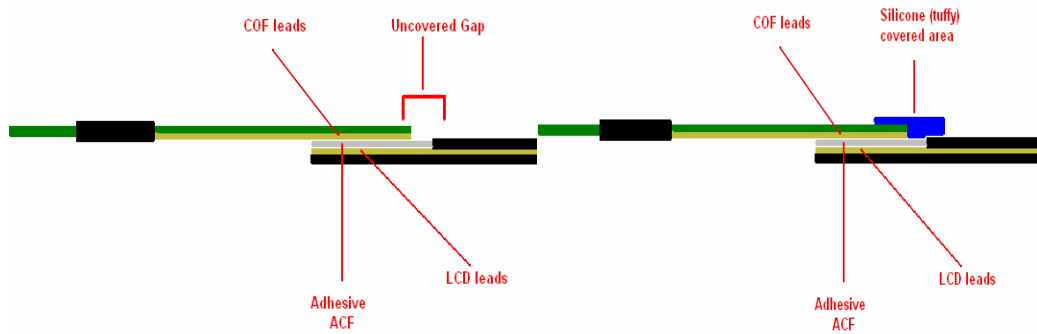

Figure 1.5 LCD modules before and after siliconizing operation

Silicone should be injected to cover whole COF’s on gate and source edges. Since some parts of LCD module are not effective on signal transmission, silicone is not injected on these parts. This application prevents inessential siliconizing. Target areas for siliconizing operation for 32 inches LCD module is as shown in Figure 1.6.

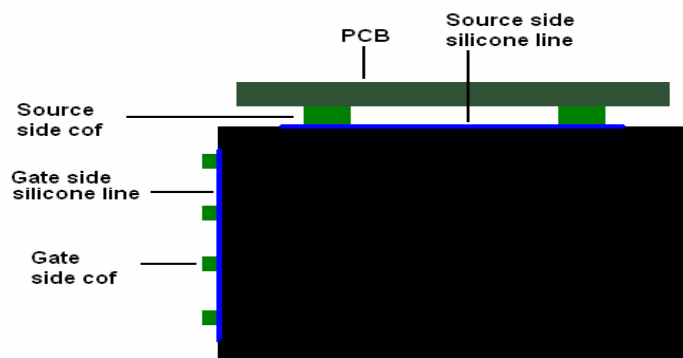

Figure 1.6 Target areas for siliconizing operation for 32” module

If we consider a JI bonding line with 23.5 seconds cycle time, these manual operations will repeat almost 2400 times and can cause a big loss of manpower and time. It is obvious that it is necessary to make this process more efficient and fast.

For an efficient and fast carrying and siliconizing processes, a machine that makes manual operations automatically must be developed. JI silicone dispenser machine was designed with purpose of full automating for manual operations. Making manual operations automatically with a machine provide us to reduce process control and silicone operator quantity from 4 to 2. There will be only 2 pieces test members with no silicone operator.

In this thesis, a JI silicone dispenser machine has been designed, constructed and controlled through the use of the main elements of an industrial automation system. The developed JI silicone dispenser machine can be discussed in two different topics; namely, mechanical design and automation system design. We explain the details of these topics and give the summary of subparts of this thesis in the following:

i) In mechanical design, the mechanical operations of JI silicone dispenser machine are described and the mechanisms that execute the machine operations are selected according to basic working principles of them. 3 dimensional drawing, mechanical hardware selection, equipment manufacturing and mechanical assembly are the main parts of our mechanical design.

- *In 3D dimensional modeling part*, draft drawing is drawn with Solidworks drawing program by considering specified basic working principles and estimated dimensions of the equipments. Mechanical parts firstly are drawn separately, then these parts are assembled in the same program. According to 3D draft drawing, there are 5 basic mechanical parts as 1 piece rotary axis and 4 pieces linear axes.
- *In mechanical hardware selection part*, primarily technical expectations for mechanical moving equipments are defined. These expectations are controllability, positioning accuracy, speed, security and cost. We specify our purpose to catch the best conditions for these expectations. Mechanisms in JI silicone dispenser machine are chosen for 5 different joints as 1 piece rotary axis and 4 pieces linear axes. With these joints machine will able to move in cylindrical coordinate plane.

- *In equipment manufacturing part*, equipment manufacturing and preparing operations that executed in workshop for LCD module delivery tables and screw holes of motor flanges are discussed.
- *In mechanical assembly part*, connection methods of mechanisms to floor and each other were mentioned. In addition, the equipments that were used in order to reach optimal conditions in vibration and balance of machine were mentioned.

ii) In automation system design, working principle and structure of automation equipments used in machine manufacturing and programming details of these equipments are mainly studied. The details about the selection of control devices such as PLC, HMI and motor drivers and sensing equipments, electrical connections and software are given.

- *In control devices and sensing equipments selection part*, selection principles of industrial control devices as PLC, motor driver, operator panel and industrial sensing equipments as sensors are discussed. By the help of criterion in automation equipment selection, specific standards are developed for JI silicone dispenser machine.
- *In wiring project and connections part*, drawing steps of wiring project that was made by using Cofaso as one of the most preferred wiring program and wiring project drawing standards that helps people who see the wiring project to understand it easily, are realized. In addition to wiring project, basic wiring principles and operations as numbering of the cables in wiring project, determination of cable types used in both panel and remote equipments are determined.
- *In software part*, programming details of industrial control devices in JI silicone dispenser such as operator panel, PLC and servo drivers are implemented.

The rest of this thesis is organized as follows:

In chapter 2, we discuss the mechanical design steps of developed JI silicone dispenser machine. 3D modeling, mechanical hardware selection section, auxiliary equipment manufacturing and mechanical assembly are the main topics that are explained in detail.

In chapter 3, we discuss the automation system design steps. Control equipments and sensing equipments selection, wiring project drawing, connections and software of the control devices are the main topics that are explained in detail.

In Chapter 4, we discuss the improvements that we observed after we developed JI silicone dispenser machine. We consider the items such as sensitiveness, manpower, production speed, employee cost, defect ratio, electronic/mechanical based malfunction.

In Chapter 5, we discuss the results and possible improvements that will affect the cost, safety and accuracy of the developed JI silicone dispenser.

CHAPTER TWO

MECHANICAL DESIGN

In this chapter, we focus on the mechanical construction of the developed JI silicone dispenser machine. Essential subtasks of JI silicone dispenser machine in terms of mechanical design, can be given as follows:

- i) Takes LCD module from the unloader unit of JI bonding line,
- ii) Moves the LCD module in order to contact to silicone injector,
- iii) Moves LCD module in order to siliconize the gate edge of it,
- iv) Moves LCD module in order to siliconize the source edge of it,
- v) Rotates the LCD module in order to place it on module delivery table.

In order to accomplish these sub-tasks, we provide following mechanisms:

- i) A linear mechanism in order to bring LCD modules horizontally from unloader unit of JI bonding line
- ii) A linear mechanism in order to move LCD vertically.
- iii) A linear mechanism in order to carry the mechanisms that was mentioned in i,ii,v and siliconize the gate edge of LCD module.
- iv) A linear mechanism in order to siliconize the source edge of LCD module horizontally
- v) A rotational mechanism that places LCD modules on module delivery tables.

The flow chart that illustrates the mechanical design steps of our proposed industrial machine is shown in Figure 2.1. In the following subsections, we discuss each step in detail.

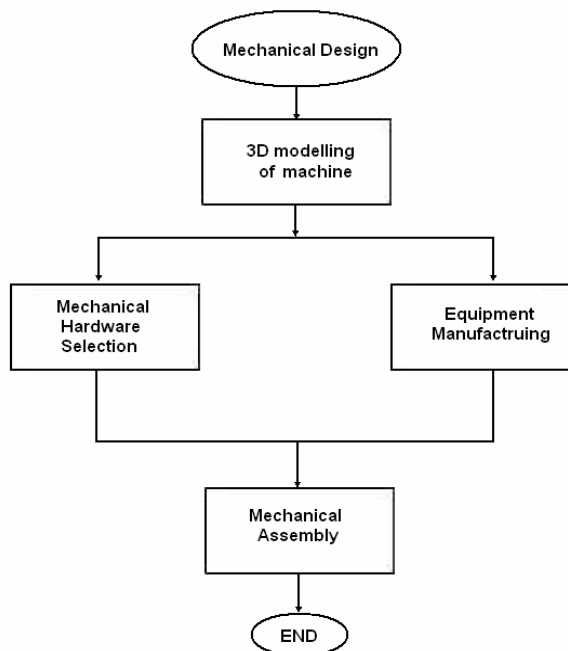

Figure 2.1 Mechanical design flow chart

2.1 3D modeling of the developed machine

3 dimensional design has been came into use in engineering studies with CAE (computer aided engineering) principles in recent years. According to CAE principles, engineering studies are executed with 3 basic steps as design, analysis and manufacturing. Design step of CAE is executed with CAD (computer aided design) programs such as Autocad, Catia, Proengineer, Solidworks. In this study, 3 dimensional draft drawing is performed by Solidworks drawing program. According to 3 dimensional drawing principles, first mechanical parts are drawn with “parts modeling” methods and then these parts are assembled.

In 3 dimensional design of JI silicone dispenser machine basic purpose is to create and determinate mechanical joints of the machine that convert manual operations to automatic machine steps after the unloader unit of JI bonding line. Since all details of mechanical parts might change, to create a certain models of parts with real sizes is not a purpose of 3 dimensional drawing. Therefore propulsion methods and bearings in mechanisms are not shown in 3 dimensional draft drawing.

In draft drawing, mechanisms of JI silicone dispenser machine are designed to develop faster, practical and reliable machine that executes target processes. After assembling of the parts, JI silicone dispenser machine became capable of moving in cylindrical coordinate plane. 3D model of developed JI silicone dispenser machine is as shown in Figure 2.2.

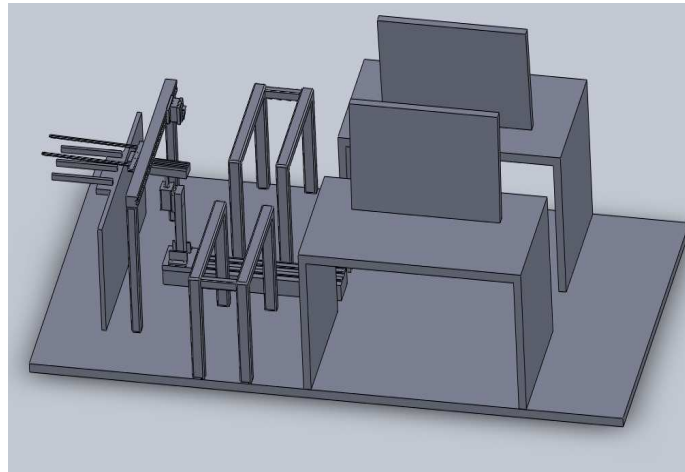

Figure 2.2 3D model of JI silicone dispenser machine

2.2 Mechanical Hardware Selection

Technical criteria were primarily identified for mechanical equipments in order to determination of mechanical hardware in detail. The most important criteria while choosing the mechanisms of JI silicone dispenser machine were specified as follows:

- i) controllability
- ii) positioning accuracy
- iii) speed
- iv) safety
- v) cost

We specified our purpose to reach the optimal conditions for 1 rotary axis and 4 linear axes with the guidance of these criteria. JI silicone dispenser machine with its 5 axes was designed with a motion capability in cylindrical coordinates.

Detailed investigations about these axes were explained in the following 2 subsections; namely, linear motion mechanisms and rotational motion mechanisms.

2.2.1 Linear Motion Mechanisms Selection

In this subsection, firstly the types of the linear mechanisms of JI silicone dispenser machine were discussed. Pneumatic and motor propulsion mechanisms were compared in terms of controllability, positioning accuracy, speed, safety and cost.

The most widely used linear mechanisms in the structure of small and middle sized industrial machines are pneumatic mechanisms and electric motor propulsion mechanisms. These two basic linear mechanism types were investigated and then compared with the criterion of controllability, positioning accuracy, speed and safety by leaving the cost criteria to end.

In pneumatic mechanisms, motion elements such as piston (cylinder) and gripper are moved by compressed air from an air pressure source. Pistons are linear motion mechanisms working with the compressed air that applies to its air inputs. Compressed air is directed by pneumatic circuit elements such as valves and venturies. Pneumatic valves control the compressed air with logic signals. Unless proportional valves are used pneumatic motion equipments can be controlled only with logic commands. This deficiency prevents to control acceleration and deceleration motions continuously especially in control of main carrier linear mechanism that has high load inertia. In addition, logic based controlled pneumatic mechanisms can not support fast start-stop and deflection operations. Therefore a mechanism that has a problem to stop at target position because of high load inertia is also doubtful for safety, it would be a serious damages in machine parts and serious injuries for workers. Beside safety, possible positioning problem of mechanisms can cause errors in siliconizing operation. Since siliconizing operation needs high accuracy in positioning, even millimetric positioning errors for linear mechanisms would cause problems such as loss of time and manpower, deceleration of production line.

If we consider cost, it can be said that pneumatic linear mechanisms are cheaper than motor propulsion mechanisms. However, if the machine construction had been assembled with pneumatic mechanisms, we would have used feedback equipments such as proximity sensor and linear scale. In this situation, we would develop a control circuit like a motor driver to drive linear mechanisms continuously. The cost for sensing and control equipments used in pneumatic mechanisms would bring away the cost advantage of pneumatic mechanisms. In conclusion, in determination of linear motion mechanisms of JI silicone dispenser machine, motor propulsion linear mechanisms are proper than pneumatic linear mechanisms according to the controllability, positioning accuracy, safety and speed criterions. When we consider driver advantage of electric motors and all disadvantages of pneumatic based linear mechanisms, it is obvious that the cost of motor propulsion mechanisms is in acceptable level. In conclusion, pneumatic motion mechanisms are not proper to use in JI silicone dispenser machine but pneumatic switching equipments such as valve and venturi should be used for compressed air transfer to special equipments such as silicone injector and stage vacuum points.

After determining linear mechanism types as motor propulsion mechanisms, it should be determined which type motor propulsion mechanisms should be used in machine. When we investigate motor propulsion mechanisms, it can be said that linear motors are the most advanced mechanisms. When we consider general linear motor structure that is shown in Figure 2.3, we can say that stator of a standard motor is distributed onto a line.

In standard motors rotation supplied by magnetic force between stator and rotor. In opposition to standard motors, motion is supplied by the magnetic force between stator and mover (linear motion stage) in linear motors. Structures of linear motors provide them advantages at start-stop and acceleration-deceleration motions.

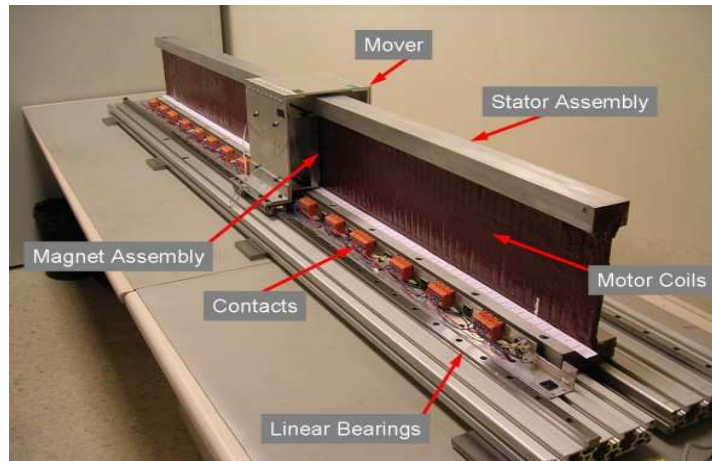

Figure 2.3 Linear motor structure (<http://www.avrasyamuhendislik.com.tr/lineermotor.php>, 2011)

Linear motor mechanisms exceedingly meet controllability, high positioning accuracy, safety and speed criteria but the cost and the procurement problems of linear motors prevent to choose this mechanism for JI silicone dispenser machine. Therefore other linear motion mechanisms were investigated.

Linear motion mechanisms used in industrial machine manufacturing generally were composed of bearing elements on aluminum and motion elements that move on bearing elements. The main principle of linear motion mechanisms is to convert the rotational motion supplied by motor shaft to a faultless linear motion. In this case for a faultless linear motion, it can be said that one of the most important parts of a linear mechanism is the guide. If linear guide is not good enough, linear motion will not be as we expect. The parts that used as guide are linear rail and shafts. The stage on the linear guide is connected from holding points to the guide. Mover stages should be mounted on linear guide in form that stage can not vibrate or leave from the guide while stage move on guide direction. An example of linear guide structure is as shown in Figure 2.4.



Figure 2.4 Linear guide and mover stage (<http://www.makina-market.com/tr/dogrusal-hareket-sistemleri/blok-yataklamlar.html>, 2011)

2.2.1.1 Main Carrier Mechanism Selection

At the present time, small and middle sized industrial machines assembled with the linear mechanisms that were based on linear guide structures. JI silicone dispenser machine mechanisms are based on linear guide method, have been determined according to the following specifications:

- i) Bearing type
- ii) Maximum speed
- iii) Load capacity
- iv) Propulsion method
- v) Length
- vi) Section
- vii) Cost

The first investigated mechanism of JI silicone dispenser machine is main carrier linear mechanism. It was planned to carry 3 different linear mechanisms as shown in Figure 2.5.

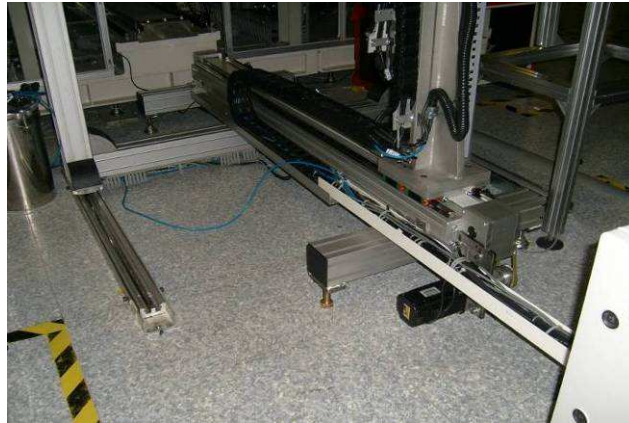

Figure 2.5 Main carrier mechanism

Main carrier linear mechanism was designed with purposes as to take LCD modules from unloader unit then to siliconize the gate side of LCD modules and finally to bring siliconized LCD module to LCD module delivery tables. In our case, when limit sensor margins are added to motion distance of the mover stage, whole length of main carrier mechanism is calculated as 200 centimeters.

A linear motion bearing can be done practically by passing the linear guides through linear bearings placed into the mover stage as shown in Figure 2.6. This type of linear bearing would have a little cost. However, machine parts make same motions 2400 times in a day with 23.5 second cycle time.

In addition to loop quantity in a day, when we think about 200 centimeter length of main carrier linear mechanism, it is obvious that a deflection would occur on guide shafts and ball screw with the effect of the load on mover stage. In this type of bearing, millimetric positioning errors occur. Therefore bearing with unsupported linear guide shafts was not preferred in the main carrier linear mechanism.



Figure 2.6 Bearing with unsupported linear guide shafts (<http://www.makina-market.com/tr/dogrusal-hareket-sistemleri/profil-ici-yataklamlar.html>, 2011)

Instead of using unsupported guides in bearing, in order to solve deflection problem, it had better to fix them to the stage. Bearing with supported linear guide shafts are as shown in Figure 2.7.



Figure 2.7 Bearing with supported linear guides (<http://www.makina-market.com/tr/dogrusal-hareket-sistemleri/modul-yataklamalar/174-dkm-32-vidali-modul.html>, 2011)

In investigation about linear mechanisms, in addition to linear ball bearing based mechanisms, it can be said that linear mechanisms that was composed with carts are also popular bearing equipments.

Inner surface of these carts are covered with ball bearings and they can move on several sized linear rails. The typical carts are as shown in Figure 2.8. (Can, M. & Gavas, M. & İpek R., 2004).

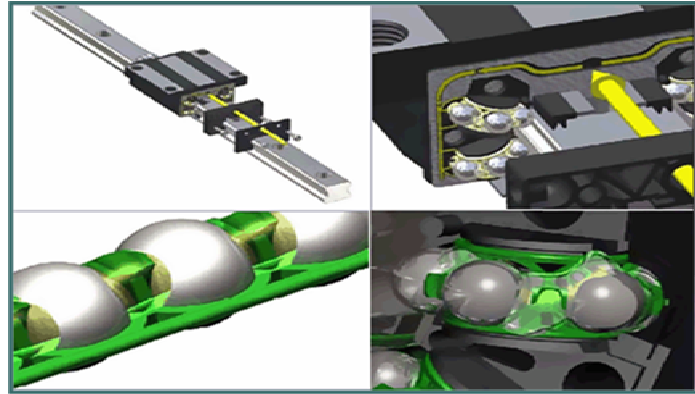

Figure 2.8 Linear cart ball bearings (<http://www.redomayer.com/lineer.htm>, 2011)

The bearing type that has shown in Figure 2.9 is a roller type bearing. In this type there is no ball bearing, mover stage is placed on rail with rollers.



Figure 2.9 Roller type bearing (<http://www.kozanlimuhendislik.com/index.php?MenuID=94>, 2011)

3 bearing types that were discussed are the most preferred bearing methods in industrial machine design and these methods are proper to use in JI silicone dispenser machine but the best one of them must be found. According to investigation about bearings, mechanisms with linear bearings are slower than the other mechanisms with average 2 m/s max speed.

Bearing in linear mechanisms is very important about rigidity. As shaft length increase, strength of shaft to vertical loads decreases so deflection on shaft increases. Although guide shafts are fixed to the stage, deflection occurs also depending to shaft section and load. Since deflection in main carrier mechanism for siliconizing operation, both linear bearing methods were elected.

Mechanisms with roller type bearing are faster than mechanisms with linear bearing with average 2.5 m/s max speed. However, rollers are connected to rail directly therefore failures can be seen on moving of stage depending on deformations on rollers.

Linear carts allow mechanisms to move faster than other two bearing methods with average 2.5 m/s max speed. In addition, load capacities of mechanisms with linear carts are higher than mechanisms that consist of other bearings. Finally, if we consider the cost, it seems that linear cart equipments are not the cheapest method among the bearing types but when we consider the other advantages of linear carts, a little difference in the cost seem to be acceptable. In conclusion, among the bearing equipments, linear cart method was preferred to use in main carrier mechanism depending on the criterions such as maximum load capacity, speed and cost.

Choosing of support profiles that was generally made with aluminum are very important in linear mechanisms. The section of support profile used in main carrier mechanism was determined as 90 mm*180 mm depending on length of the mechanism and load. Preferred section of profile is enough to prevent the vibration that occurs during the motion of mover stage.

There are two basic propulsion methods used in linear motion mechanism such as trigger belt-pulley and ball screw. When screw ball structure is examined, there can be seen a shaft that was shaped as a screw and a nut that ball screw passes through it. As working principle of ball screw, depending on rotation of a motor shaft that was connected to ball screw, nut will move linearly with a linear guide. In this case, rotational motion of motor shaft is converted to linear motion.

In order to decrease the friction between nut and ball screw, balls were placed on inner surface of nut. Balls can move through spiral channels and help nut to move easily.

In ball screw propulsion mechanism that is shown in Figure 2.10, there are two important equipments such as motor side and end nuts. These fixed nuts are chosen depending on ball screw section but at the same time, it is very important to fix these equipments to mechanism well. If we don not pay attention to fixing position and strength to stage of nuts, it causes noise and then damages on nuts and affects linear motion and maintenance frequency of mechanism.



Figure 2.10 Ball screw equipments (www.nskeurope.com.tr/cps/rde/xchg/eu_tr/hs.xsl/urunler-vidali-miller.html, 2011)

In application of ball screw, there are few criterions such as maximum dynamic and static load capacities, critical speed and twisting factor. Depending on these criterions length, section of ball screw is determined. Because of critical speed, ball screw based mechanisms can not be moved very fast. Limitations about speed, load and twisting factor prevent the manufacturing of the ball screws more than 1 meter length. Instead of manufacturing long and thick ball screws, generally trigger belt-pulley pair is preferred.

In a trigger belt-pulley mechanism, tense trigger belt is placed around fixed pulleys. Trigger belt is passed through a mover stage that is placed on a linear guide with a bearing. Similar to gear-chain mechanism, as the motor shaft rotates the pulley, mover stage makes a linear motion with the help of linear guides. An example of trigger belt-pulley mechanism is shown in Figure 2.11.

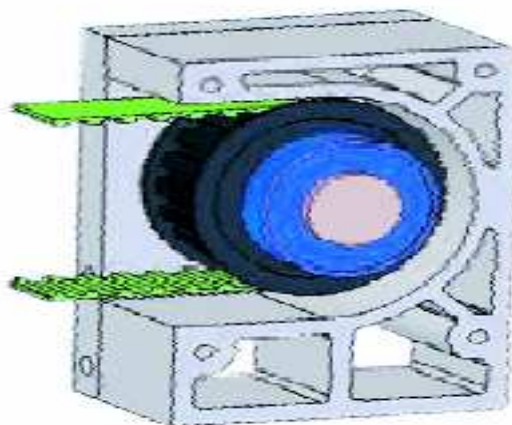

Figure 2.11 Trigger belt-pulley mechanism (<http://www.makina-market.com/tr/dogrusal-hareket-sistemleri/yataklama-ekipmanlari.html>, 2011)

Load on mover stage is calculated 25 kg by considering all equipments on main carrier mechanism. In this case firstly, an investigation was executed if a trigger belt-pulley based mechanism can carry this load with success or not. Depending on the application direction to mover stage, maximum load capacities of a linear mechanism that has a profile with 90mm*180mm section, are as shown in Figure 2.12. This mechanism has a load capacity as 550 kg in vertical direction to mover stage. In this case this mechanism can carry the load of main carrier mechanism as 25 kg without any problem. In addition, equipments on mover stage have total of 60 cm length. Even the situation that the gravity center of the equipments are on top point of the equipments on stage, moment on mover stage ($250 \text{ N} \cdot 0.6 \text{ m} = 150 \text{ Nm}$) remains less than MZ moment (209 Nm).

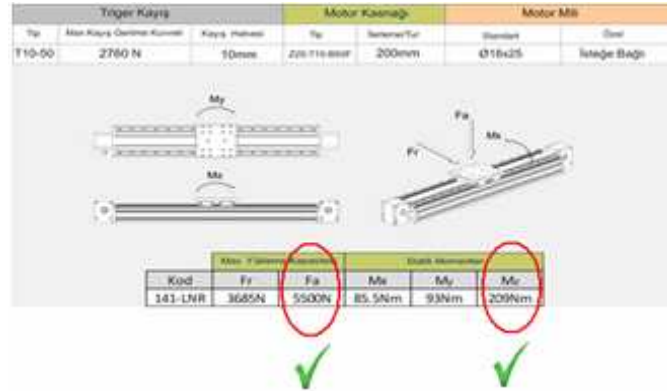

Figure 2.12 Load and moment data of 90mm*180mm section linear mechanism (<http://www.makina-market.com/tr/dogrusal-hareket-sistemleri/modul-yataklamalar/triger-tahrikli-moduller/43-lineer-triger-modul-90x180.html>, 2011)

After we see the disadvantages in ball screw propulsion mechanisms, about maximum speed capacity of trigger belt-pulley based linear mechanism that has profile with 90mm*180mm section was investigated.

Linear mechanism that we have considered, has 5 m/s maximum speed. This maximum speed value is almost twice ball screw based mechanisms that have same sizes. Beside the speed advantages, trigger belt-pulley based mechanisms capture attention with low cost.

After all investigations depending on criterion as maximum speed and load capacities, propulsion method , length , profile section , cost, a trigger belt-pulley based mechanism with 90mm*180mm profile section was approved to use for main carrier mechanism.

2.2.1.2 XU Side Silicone Mechanism Selection

In order to silicone from 26 inches to 37 inches modules, length of source edge silicone mechanism was determined as 1.2 meter. It can be remembered from the research results done for main carrier mechanism that length of a ball screw based mechanism more than 1 meter is not appropriate to use. In this case source edge silicone mechanism should consist of trigger belt-pulley.

In order to choose this mechanism as a trigger belt-pulley based also will make it very fast. The load that is carried on mover stage of source edge mechanism is almost 1.5 kg therefore to use a mechanism with 80mm*80mm profile section will be proper. There are mechanisms that have less than 80mm*80mm profile sections as 45mm*45mm but since source edge of 37 inches module is very long, in order to prevent the vibrations on silicone injector, section of aluminum support profile was determined as 80mm*80mm. Since the length and profile section of the mechanism are small, to use a linear cart as the most reliable bearing equipment does not cause very big cost. In conclusion, a linear trigger belt-pulley based mechanism with 80mm*80mm profile section was preferred for source edge silicone mechanism as shown in Figure 2.13.

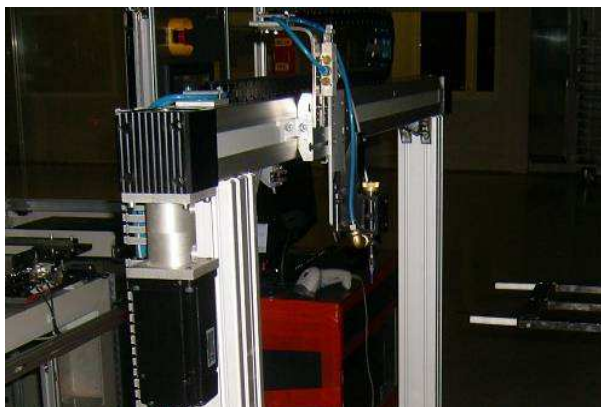

Figure 2.13 XU side silicone mechanism

2.2.1.3 LCD Module Carrier Mechanism Selection

Instead of using a mechanism to take LCD modules from JI bonding line and carry them to test tables, a fixed stage with 100 centimeter length could be used . However even a possible deflection in vertical direction as 1 mm could cause the silicone operation to be unsuccessful. In order to prevent this problem, when a 100 centimeter fixed stage that is made even with aluminum with 100cm*40cm*3cm sizes, cost of the fixed stage will be equal to almost cost of a linear motion. In addition to cost, it is not certain that there will not occur deflection and vibration in time. Because of the risks as cost, deflection and vibration issues, fixed stage was not used.

Instead of using 100 cm length fixed stage, 60 cm length linear mechanism with a 60 length mover stage was preferred. Depending on mostly cost factor linear cart based mechanism was used and support profile of the mechanism was preferred with 45mm*90mm section. A linear mechanism with 45mm*90mm profile section can prevent effects of the vibration caused by motion of main carrier mechanism, on LCD modules. Since the length of the LCD module carrier mechanism that is as shown in Figure 2.14 is less than 1 meter and there is no speed problem for 60 cm length, propulsion method of this mechanism is determined as ball screw.



Figure 2.14 LCD module carrier mechanism

2.2.1.4 Vertical Motion Mechanism Selection

Vertical motion mechanism make its motion against to gravity force that caused by equipments on this mechanism. In ball screw based mechanisms, it is very hard to move the stage by applying the force on mover stage. Since only the ball screw based mechanisms help to hold mover stage against to gravity force, ball screw propulsion is preferred for vertical motion mechanism. Vertical motion mechanism was determined with a capability to carry rotational motion mechanism, LCD module carrier mechanism and other support and assembly equipments.

In addition to load capacity, rotational motions on vertical motion mechanism are a very important factor in determination of this mechanism. When we consider the rotational motions that repeat 2400 times in a day, it is obvious that there will be rotational strains on the fixing points of mover stage connected to linear guides.

In this case, to use a roller type bearing seems illogical. Beside this, the length of vertical motion mechanism is 40 cm and to make bearing of the mechanism with linear cart method is also proper for the cost. Linear motion mechanism with 45mm*90mm profile section that is as shown in Figure 2.15 is preferred by considering propulsion method, bearing method and mechanism length.



Figure 2.15 Vertical motion mechanism

2.2.2 Rotational Motion Mechanism Selection

In this subsection, rotational motion mechanism of JI silicone dispenser machine was determined. We have tried to reach optimal connection in order to create a long-lasting and durable mechanism. A motor shaft can not be coupled to a load directly, there must be a transfer and buffer element between the load and motor shaft. Rotational flange is used for a proper connection for rotational motions. Flange has two sides as motor connection and load connection.

Flange transfers the rotational motion of motor shaft to load with minimum friction by courtesy of balls in its structure. In load side of flange, load contacts to flange with several screws, this makes the connection between load and flange strong and reliable. In this case, a possible strain occurs in load side does not damage motor shaft, strain affects on only connection screws of load. Rotational motion mechanism that was made by using flange is as shown in Figure 2.16.

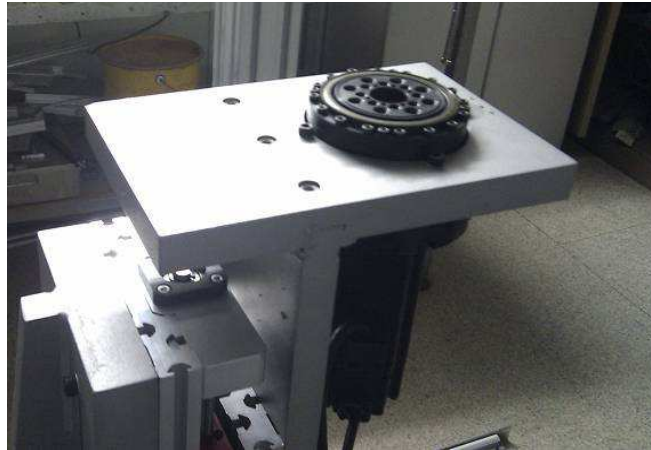

Figure 2.16 Rotational motion mechanism

2.2.3 Mechanical Support Equipments Selection

In mechanical support equipments section firstly the reducers was investigated. Working principle of reducers and types of the reducers that are used in mechatronic systems were mentioned. After our researches, essential specifications of reducers were defined. In this section in addition to reducer selection, the places and the structure of mechanical support equipments that were used in order to reach optimal working conditions without vibration in steady state, were determined.

2.2.3.1 Reducer Selection

The working principle of reducers basically depends on gearwheel working principle. In gearwheel as shown in Figure 2.17 has a ratio between the diameter and speed of wheel. According to gearwheel working principle, while the wheels in contact turn together, speed of wheel that has small diameter is higher than speed of wheel that has large diameter. However, moment supplied by the wheel that has large diameter is higher than moment supplied by the wheel that has small diameter. Gearwheels allow us to work with high loads by applying low force but there is no change for energy or work.

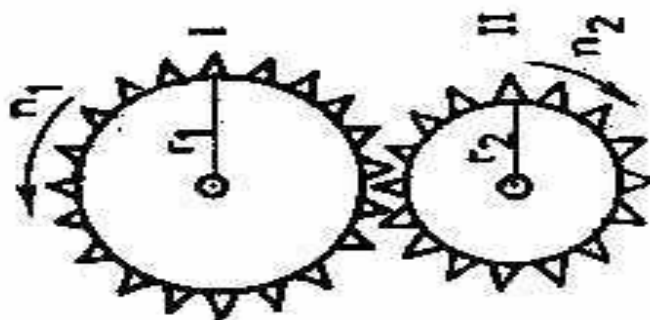

Figure 2.17 A gear wheel structure (<http://egurcay.wordpress.com/2011/04/12/disli-cark/>, 2011)

In many mechanical systems, since high load, several wheels might be used. In gear wheel mechanisms rotation direction can be changed. In a gearwheel mechanism, if the diameter of a wheel is 5 times bigger than a diameter of any wheel, when the large wheel turns 1 times, small wheel will turn 5 times. Reducer is a gear box which has several gearwheels in its structure, increases the moment of motor shaft that we couple it to. In many small or middle sized industrial machines, moment is more important than speed for motors in mechanisms. If an electric motor can not correspond to load moment, motor need excessive current. By the rise of current, motor fuse blow out or if exist, an alarm message about excessive load occurs on motor driver and this causes stoppages for machine. Reducers firstly were developed to solve torque problems as mentioned.

A reducer was decided to use in main carrier mechanism after an instability that was caused by high load was noticed in motion of mover stage of mechanism. In order to supply enough torque to load a reducer with 1:15 reducer ratio was coupled to motor shaft. In this case, torque of the mechanism increase when the speed of mover stage decrease. In order to increase speed, electric motor has a high nominal speed was used. Since speed limit of main carrier mechanism is 5 m/s, there is no problem to adjust high speed values for mover stage.

If main carrier mechanism was selected as a ball screw based mechanism instead of trigger belt-pulley based mechanism, reducer would not be used but motor size would be selected higher in order to meet the torque. In this case, main carrier mechanism would be a slower and high-cost.

There are several types of reducers but planetary gear reducers is the most preferred ones for mechatronic systems. Planetary gear reducers are preferred because of their advantages as low noise, to give high moment with small size, easily greasing and maintenance. There are 4 basic equipments in this type reducer as shown in Figure 2.18. Sun gear got its name because it placed in the center of other gears. Sun gear can be as fixed and motion transmission element or according to motion it can be used as input or output element.

Planet gears turn around the sun gear and the equipment that connect planet gears each other is planet carrier. Ring gear that is the largest gear, covers the sun gear and planet gears.

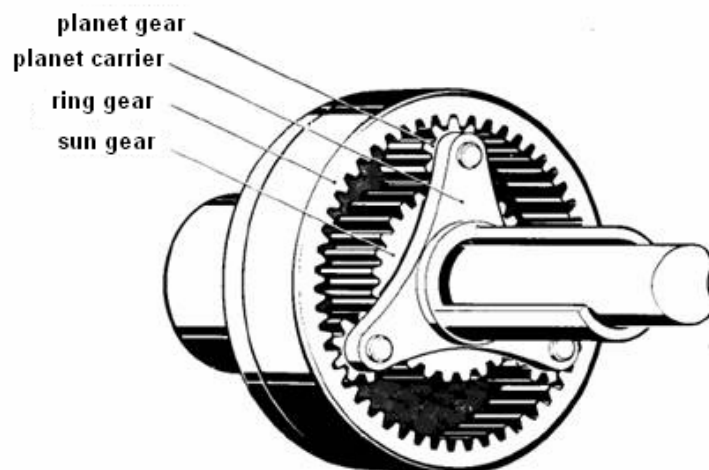

Figure 2.18 Planetary gear (http://www.obitet.gazi.edu.tr/obitet/sasi_ve_guc_aktarma_organlari/planet_disli_sis.htm, 2011)

Since our purpose to increase moment of motor in main carrier mechanism, a reducer that increases the torque was selected. There are several methods in torque increase mode:

- When sun gear is fixed, ring gear is used as motion input and carrier is used as motion output, rotation directions of sun gear and carrier become same. Moment increases but speed decreases.
- When ring gear is fixed, sun gear is used as motion input and carrier is used as motion output, rotation directions of sun gear and carrier become inverse. Moment increases but speed decreases.
- When carrier is fixed, sun gear is used as motion input and ring gear is used as motion output, rotation directions of sun gear and ring gear become inverse. Moment increases but speed decreases.

One of the most important property of planetary gear reducers is minimized gear gap. In planet gear reducers used in current mechatronic systems are used with Standard gap as 0.25 degree, low gap as 0.08 degree and minimum gap 0.05 degree. The more gear gap decrease the more positioning in linear motion become accurate. Reducer in main carrier mechanism is as shown in Figure 2.19.



Figure 2.19 Reducer in main carrier mechanism

2.2.3.2 Support Blocks Selection

In this subsection, the places and the structure of mechanical support blocks that were used in order to reach optimal working conditions without vibration in steady state, were determined. Mechanical support blocks play important role to reach optimal performance in machine.

Support blocks that were not properly selected and assembled often might cause lost on cost, time and manpower. Iron support block that hold whole equipments together on main carrier mechanism and iron support block that hold rotation flange is shown in Figure 2.20. Iron blocks increase the load on main carrier mechanism but these blocks are very important to prevent possible deflection on support blocks and to provide stability on vertical and horizontal motions.



Figure 2.20 Iron support blocks on linear mechanisms

2.2.4 Pneumatic Panel and Pneumatic Equipments Selection

In this subsection, the equipments in pneumatic panel were introduced and the working principles of pneumatic equipments such as venturi, valve, silicone vessel and silicone injector were mentioned.

It has been mentioned that pneumatic motion equipments would not be used in JI silicone dispenser machine before.

Pneumatic equipments except motion equipments were used for functions that were controlled by pneumatic panel such as to fix LCD modules to mover stage of module carrier mechanism, to transfer pressurized silicone that came from pressure vessel to silicone injector. Compressed air is supplied to pneumatic panel as shown in Figure 2.21. Air is directed 3 branches to silicone vessel, pneumatic valve that is used to switch the air on silicone injector input point and venturi(vacuum generator). Analog display placed on pneumatic panels show air pressure levels of these 3 branches.



Figure 2.21 Pneumatic panel

LCD modules stay on mover stage of module carrier mechanism after they are taken from JI bonding line until leave them to LCD module delivery tables. During the siliconizing and carriage processes LCD modules must be fixed well on mover stage because of positioning accuracy for silicone operation and also for safety. In condition that a possible problem occurs on vacuum of module carrier stage, modules can fall off and can cause injuries. Therefore vacuum level on module carrier stage must be checked. The sensor that provides us to check vacuum level is called as digital pressure-vacuum sensor. Low and top limits can be specified with this sensor and it gives a logical output signal to inform PLC about the problem in vacuum level.

The pressurized air that came from pneumatic panel to venturi is converted to vacuum with a converting method as shown in Figure 2.22. According to working principle on this method, pressurized air is transferred to a channel with small section.

In this case, speed of pressurized air increases while its pressure decreases in channel that has small section. By the decrease of the air pressure in channel with small section, air flow begins from outside to other channel connected with the channel with small section. This inverse air flow is distributed to all vacuum points on module carrier stage. LCD modules can be held fixed during all operations.

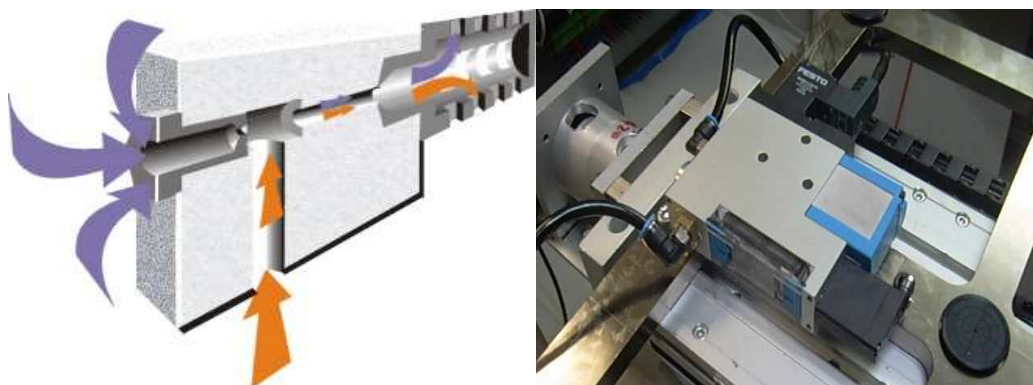

Figure 2.22 Working principle of venturi on module carrier stage (venturi, 2011)

In order to make siliconizing in acceptable level in addition to success of motion mechanisms, silicone grade is also an important factor. Since our purpose is to cover conductors that are in contact with air directly, the flow speed and pressure of silicone must be in a specified level. In this case, silicone vessel as shown in Figure 2.23 is used as a source for silicone injector. Silicone vessel with its manual valve supplies an adjustable pressurized silicone and an analog display that we can follow the pressure level in vessel.



Figure 2.23 Silicone Vessel

The valve that is as shown in Figure 2.24 allows air flow to silicone injector when it gets a digital signal from PLC, depending on program steps. 2 PLC steps as source and gate edge siliconizing steps require to enable this valve. When the valve directs air pressure to silicone injector, silicone flows onto target lines of LCD module.



Figure 2.24 Connection between pneumatic valve and silicone injector

The silicone injector that is as shown in Figure 2.25, consists of an adjustment screw and silicone output pin. The most important thing of silicone injector is contact to LCD module correctly, because silicone pin must be placed on LCD module with no pressure. If pin presses to module surface so much, silicone density on module do not be as expected. Therefore position of injection pin must be adjusted well in vertical direction.



Figure 2.25 Silicone injector

2.3 Equipments Manufacturing

In this section, equipment manufacturing methods and manufactured parts of JI silicone dispenser machine were mentioned. In industrial machine manufacturing, most of the mechanical equipments are purchased depending on design. In addition, some special parts that were self-manufacture of machine producers decrease the mechanical cost. At the present time, self-manufacturing is done with lathe and milling as classic workshop mechanisms and also with CNC (computer numerical control) techniques that depend on CAM (computer aided manufacture).

Motor flanges were not ready to assembly when we got it, since they had no screw holes. Screw holes creating and other operations such as drilling, shaping on many connection equipments has been realized in workshop conditions. In addition, in order to decrease the cost, esd(electrostatic discharge) protected LCD module delivery tables that are as shown in Figure 2.26, were manufactured in workshop by using idle metal parts.



Figure 2.26 LCD module delivery table

2.4 Mechanical Assembly

In mechanical assembly section, connection methods of mechanisms to floor and each other were mentioned. In addition, the equipments that were used in order to reach optimal conditions in vibration and balance of machine were mentioned.

In mechanical assembly as the last step of mechanical design, mechanical parts are connected to machine floor and each other with suitable connection equipments, in a form that there would not be any vibration on any part during the motions.

The most preferred connection equipments used in assembly of JI silicone dispenser machine are corner type fitting equipment as shown in Figure 2.27. In assembly of LCD module delivery tables, main carrier mechanism and balancing legs profile nuts were mostly used.



Figure 2.27 Corner type fitting equipments and profile nuts

Although whole mechanical parts were selected and assembled carefully, there can be occur some problems on machine balance after assembly ended. The purpose to use the legs that is as shown in Figure 2.28 is make LCD module plane adjustable. Any problem that occurs on machine balance in time can be removed by using the adjusting screws under the legs. Balancing legs usage indicates one of the most important point for mechanical equipments as adjustability, because even you use the best mechanisms or techniques in your machine, if mechanical parts are not adjustable, you must change them when a problem occurs. In this case, parts that can not be adjusted cause loss of time and money.



Figure 2.28 Balancing legs

Another practical application in JI silicone dispenser is mobile source edge silicone mechanism. Movement capability about 1 meter is provided to source edge silicone mechanism by courtesy of the rails that are shown in Figure 2.29 in case of maintenance operations in unloader unit of JI bonding line. In addition, by removing XU side silicone mechanism from unloader unit, silicone operation can be executed manually like before we made JI silicone dispenser machine.

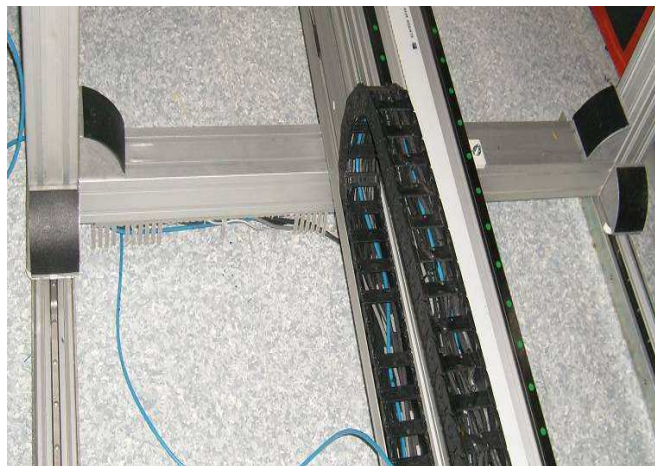

Figure 2.29 The rails of source edge silicone mechanism

In order to connect the motors to mechanisms, two necessary equipments such as motor flange and coupling were used. Coupling is used to connect the motor shafts to motor connection points of the mechanisms, flange is used to connect motor trunks to motor connection points. Flange is generally made with aluminum.

Flange usage is not an obligation, because flange can connect another fixed equipment except mechanism trunk. In a motor connection, coupling is placed into the holes in flanges. Motor flange that is shown in Figure 2.30 is used to connect motor to source edge silicone mechanism. Couplings in flanges sometimes need adjustment from their set screws. Screw holes on flange help us to adjust coupling set screws.



Figure 2.30 Motor connection of source edge silicone mechanism

Couplings are manufactured according to sections of the motor shafts. If motor shaft is wanted to connect a mechanism directly, coupling must be used. Couplings with the spring in their structure, provide a flexible connection between motor and mechanism shafts. This flexible connection is broken with a little force and protects the motor shafts against to damages. Direct connection equipments such as flange and coupling are used in vertical motion mechanism, module carrier mechanism, source edge silicone mechanism. In main carrier mechanism, since there is a reducer connected to motor shaft, trigger belt-pulley that is shown in Figure 2.31, is used to make motor connection.



Figure 2.31 Motor connection of main carrier mechanism

CHAPTER THREE

AUTOMATION SYSTEM DESIGN

In automation system design of JI silicone dispenser machine, working principle and structure of automation equipments used in machine manufacturing and programming details of these equipments were mainly mentioned. In this chapter, according to automation system design flow chart , there are sections about the selection of control devices such as PLC,HMI and motor drivers and sensing equipments, electrical connections and software.

Similar to the chapter of mechanical design, the chapter of automation system design was composed with sequential sub-headings that were explained in detail. Industrial automation system design steps of JI silicone dispenser machine are as shown in Figure 3.1.

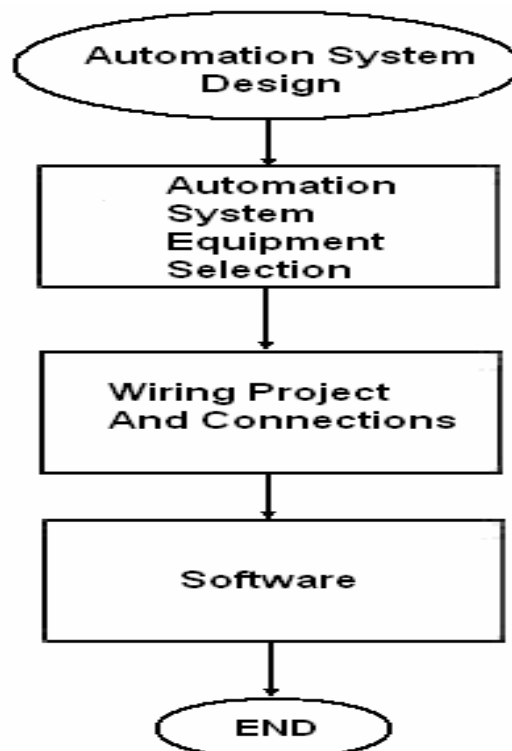

Figure 3.1 Automation system design flow chart

3.1 Automation System Equipment Selection

Determination of automation equipments is very important to prevent possible problems that occur during the assembly and software processes. Especially not to purchase industrial control and sensing equipments according to their technical specifications causes extra costs. Determination of industrial automation equipments of JI silicone dispenser machine was discussed in two branches as industrial sensing equipments and industrial control devices. Industrial sensing equipments are the sensors and industrial control equipments are motor driver and motor, operator panel (hmi), PLC.

3.1.1 Control Equipments Selection

In control equipments section, selection of control equipments such as PLC, motor, HMI was explained. In motor selection subsection, the motors that are used in automation technique were compared in order to select optimal motor type. In PLC selection subsection, basic information about PLC's and the required specifications about PLC of automation system of JI silicone dispenser machine were mentioned. In HMI selection subsection, importance of HMI usage in automation systems and the required specifications about HMI of automation system of JI silicone dispenser machine were mentioned.

3.1.1.1 Motor Selection

When we consider the cost of motors and drivers, we can see that motor costs are more than half of total industrial control equipment cost therefore we can understand the importance of motor selection better. In motor selection pre-selection criterion such as positioning capability, speed and torque values and size are used.

In standard automation systems, servo, step, asynchronous motor and partly dc motors are used. In investigation about motors, it is noticed that dc and asynchronous motors are mostly used in conveyors and lifting mechanisms instead of industrial machines. It can be also said that dc and asynchronous motors are not proper according to motor pre-selection criterions. (Türkeş, E. & Orak, S. , 2008).

The most preferred motor types in industrial automation systems are servo and then step motors. These type of motors that are proper for motor pre-selection criterion should be investigated also in detail by comparing step by step before use them in machine.

Step motors are designed not only for continuous motion but also for systems that require high accuracy for positioning. Step motors are smaller than the other motors with same capacity. Step motors can move by steps and work with low positioning errors in steps.

Positioning errors of each steps are specific and do not accumulate by steps. Step motors are basically brushless dc motors and are composed of two parts similar to other dc motors. Rotational part that consists of permanent magnets is called as rotor, fixed part that contains coils is called as stator. The basic structure of a step motor is as shown in Figure 3.2. (Step motor ve sürülmesi, 2007).

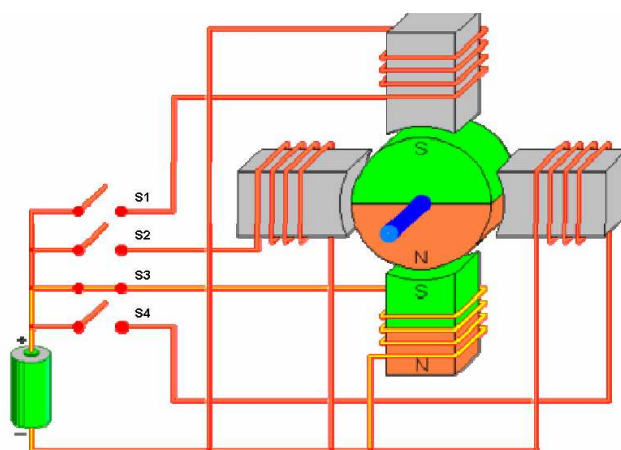

Figure 3.2 Step motor structure (<http://www.scribd.com/doc/57082143/motorDokuman>, 2011)

The permanent magnet in the middle turns with effect of the magnetic force on the coils that were placed around it. In order to move the rotor, S1, S2, S3 and S4 switches should be turn sequential and one by one. Step angle is the angle that occurs with one switching and it depends on pole quantities in step motor structure.

Since it has 4 coils, step motor that is shown in Figure 3.2 has step angle as 90 degrees, it turns 90 degrees with one switching. However 90 degrees step angle is not enough for precise positioning. (Motor nedir?, 2011)

At the present time, step motors with step angles as 3.6, 1.8 and 0.9 degrees are used in many applications that require high positioning accuracy. Step motors are named with step quantities in one turn. As an example, a motor with 200 step turns has a step angle as 1.8° ($360/200 = 1.8^\circ$). The more the step quantity in a turn increase, the more the positioning precision and also the motor cost increase. The other important terms about step motors can be explained as below:

- Step Accuracy: This term explains positioning accuracy as percentage of step angle.
- Holding Torque: When motor has zero speed, motor shaft is under the influence of holding torque. If motor shaft is tried to rotate manually, holding torque prevents the rotation but in condition that any load achieved to rotate the shaft, holding torque disappears.
- Torque – Inertia Ratio (TIR): TIR represents the effectiveness for a step motor. $TIR = \text{Rotor Inertia} / \text{Holding torque}$
- Dynamic Torque: Dynamic torque which is shaft torque during the motion is always lower than holding torque even motor is worked on low speeds.

Step motors work with commands sent by step motor driver that can make high speed switching. Step motor driver sends pulses to stator coils according to input signals that came from an encoder, PC or PLC. There several control pins on step motor driver as motor phase pins, driver enable pin, direction pins and pulse pin. Since there is no display and control menu on step motor drivers, these drivers are not user-oriented devices, control of step motors is mainly based on programmer.

It is obvious that the main purpose in using of step motors is to get high positioning accuracy. When we deal with the torque capacities of step motors, it can be seen that step motors have limited torque and powers. Load inertia and friction of the mechanism step motor was coupled with, can cause position errors in open loop control of step motors. Speed-torque curve is as shown in Figure 3.3.

In speed-torque curve, it can be seen that motor has the highest torque that is called as holding torque when motor does not rotate. However the more motor speed increases, motor torque decreases significantly.

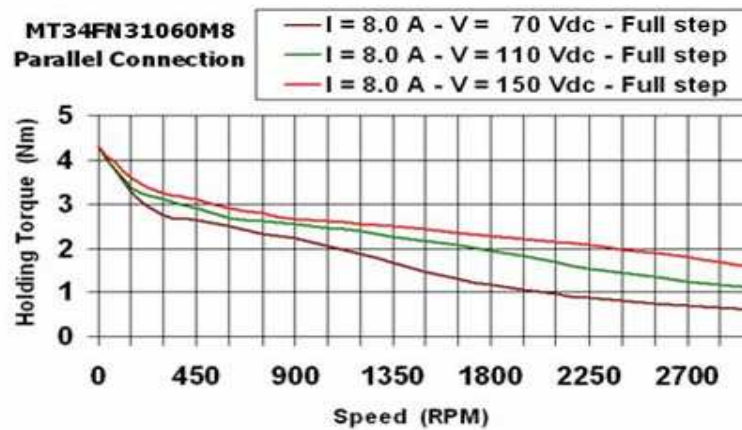

Figure 3.3 Step motor speed-torque characteristics (<http://www.robosan.com.tr/step/mt34fn31.htm>, 2011)

If the speed-torque curves of step motors are considered, in speed as 50 steps/second (150 rpm), dynamic torque is 80 percent of holding torque. However in speed as 2000 rpm, dynamic torque is 50 percent of holding torque at most. In this case, especially in selection of the motor of main carrier mechanism that is planned to move with motor speed as 2000 rpm, half of the holding torque must be considered as dynamic torque.

The word “Servo” takes its name from the word “Servant”. Therefore the word “Servo” makes us consider the servo motors as the servants that move only according to commands. Moreover servo motors execute several commands as position, speed, torque commands or a combination of these three commands. The close loop systems that have no step motor are called as servo systems. Therefore an AC induction motor that is connected to speed controller can be called as servo motor. (Krishnan, R. 1987).

Thyristor based circuits as the only control method, were used for high currents many years. The more transistors were developed to use for high currents and in high frequencies, the more the usage of servo motors increase.

Servo motors have the basic specifications below:

- Generally power motors are designed with specified speed but servo motors are designed to work in a wide speed ranges.
- Servo motors have high speed response, and this property require servo motors to have low rotor inertia rotor therefore servo motors are manufactured with low section and longer.
- Servo motors can work in low or zero speed with high positioning accuracy.
- Speed can be changed fast in other words even servo motors have small sizes, high torque can be generated by servo motors.
- Dynamic rotational torque of servo motors is high and they can work with twice dynamic rotational torques in a short period of time.
- Speed can be specified easily to any value between 1 and 10000 rpm. They can work in position and torque control with even 1 rpm speed.
- Frequency of start and stop operations do not affect the motor stability.
- Servo motors can be used in robots, CNC, automatic welding machines, press machines, packaging machines, high speed assembly machines.

Servo motors are manufactured two types as AC and DC. The working principle of DC servo motors is same with working principle of standard DC motors. DC servo motors have two basic coils on stator and armature. Both of the coils are connected to different DC sources. DC servo motors are manufactured from a few watts to a few hundred watts but generally are used in applications that need high motor power. (Servo motor ve sürücüleri, 2007).

At the present time, AC servo motors are used in both of low and high power applications. The structure of AC servo motors is simple and they have low inertia. In addition it is known that generally they have non-linear structure and in opposition to DC servo motors speed-torque curves of AC servo motors is not ideal and torque capacities of AC servo motors are lower than DC servo motors.

The most preferred motors in automation systems are AC servo motors. Therefore AC servo motors should be compared with step motors in order to use in JI silicone dispenser machine.

The speed-torque characteristic is an important determining criterion to compare the step and servo motors. Speed-torque curve of an AC servo motor is as shown in Figure 3.4.

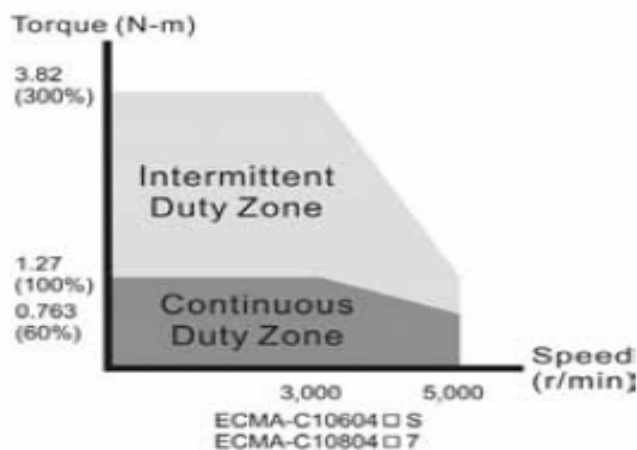

Figure 3.4 Speed-torque curve of an ac servo motor

(ASD-A2 Series User Manual, 2011)

According to graphic in Figure 3.4, servo motors have a great acceleration-deceleration and continuous work characteristics. In other words, motor torque does not change from start to high speeds. Therefore it is obvious that servo motors have more torque advantages than step motors to use in the mechanism that has varying speeds. In addition to advantages about speed-torque characteristics of servo motors, there are several advantages of servo motor drivers and motors as below:

- Servo drivers can communicate other industrial control devices.
- Servo drivers have a display that shows alarm messages, and a control menu that provides the user to adjust the parameters.
- Programmers do not have to lead all servo operations by PLC commands by courtesy of parameter adjustment property of servo driver, PLC programs are created easier.
- Servo drivers can detect the load characteristics by Auto tuning operation.
- Servo drivers can detect the position and the speed of servo motors continuously by courtesy of internal encoders on motors.

- Servo motors can contain internal mechanical brake that works with PLC commands
- Servo drivers can lead automatically reference operation of servo motors
- Servo drivers can direct the motors to internal positions that were specified by user.
- Servo motors can be worked as step motors with pulses that were sent by servo driver.
- Servo motors can be worked in different basic modes as position, speed , and torque control modes.

According to specifications above, servo motor sets have all the advantages of step motor sets, in addition servo motor sets have more advantages about programming and using conditions. In this case, although the step motor sets are cheaper than servo motor sets, AC servo motor sets must be used in JI silicone dispenser machine.

5 motors will be used in JI silicone dispenser machine. Especially motors of main carrier mechanism and vertical motion mechanism are must be selected with high torque limits. Torque values for motors that are used in JI silicone dispenser mechanism can be calculated with the formulations in Appendix 1. Torque and power values of the motors in linear mechanisms were calculated as 2.39 N.m (750W) for motors of source edge silicone mechanism and main carrier mechanism (with 1:15 reducer). In vertical motion mechanism and module carrier mechanism motor torque and power values were calculated as 1.27 N.m (400 W). JI silicone dispenser machine was assembled with selected linear mechanisms and motors as shown in Figure 3.5. (Oriental motor general catalogue, 2009).

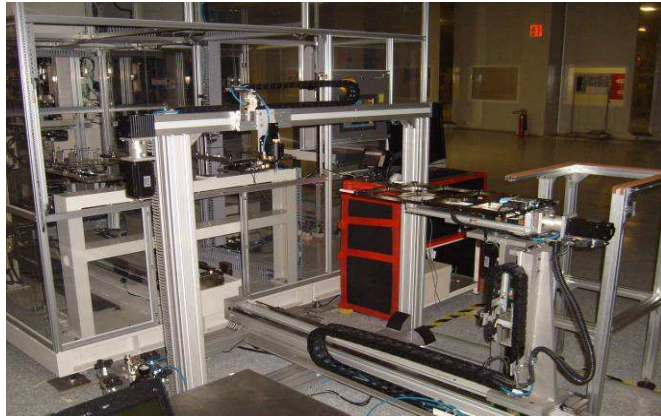

Figure 3.5 JI silicone dispenser machine

After torque and power values of motors were specified, a detailed investigation was executed for servo motors and servo drivers. Delta AC servo set that was shown in Figure 3.6 was selected for all mechanisms because it provides all specifications about a servo set with the lowest cost. In the structure of Delta servo motors, there are basic motor components such as motor power input and encoder signal output points and also encoder, bearing and shaft.



Figure 3.6 Delta servo set (http://www.fastltd.net/asd-a2_serisi-494_tr_cd.html, 2011)

Delta AC servo driver is a device that works with sinusoidal pulse width modulation and can make signal processing with analog and digital signals.

A rotary encoder as a feedback device is used to sense the rotation of shaft in servo motors. Internal rotary encoder that was connected to motor shaft converts the rotation data to electrical signals with a specified resolution.

As an example, encoder that is as shown in Figure 3.7, works with light sensing. The light that come form led source passes through the holes on a disk and falls on a photo sensor. In this case, when disk is connected to motor shaft, disk rotates with the effect of the shaft and light situation on photo sensor changes logically. The output signal of photo sensor that occurs with light, is counted and sent to servo driver.

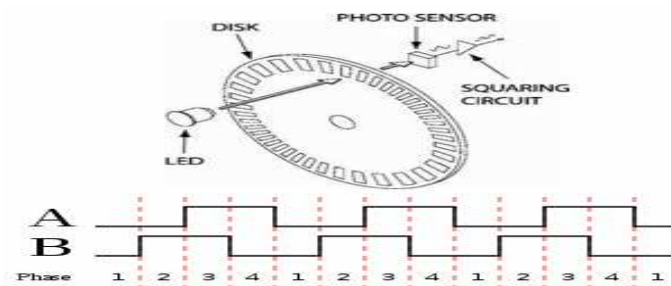

Figure 3.7 Signals of a rotary encoder (<http://www.cncmentor.com/rotary-encoders-and-linear-encoders>, 2011)

20 bit internal encoders that has 1280000 ppr(pulse per rotation) resolution is used in Delta servo motors. The signals that are provided by encoder is transmitted to servo driver and position of motor shaft is defined with two form as absolute and incremental. AC servo motor feedback system is as shown in Figure 3.8.

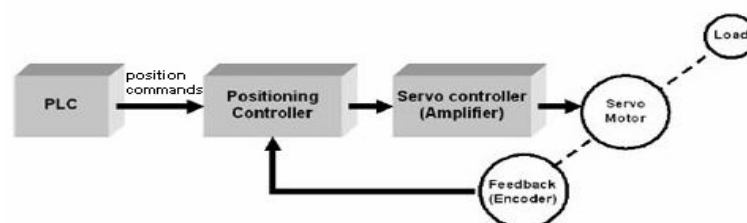

Figure 3.8 AC servo motor feedback system (<http://www.tryplc.com/> (<http://www.tryplc.com/Articles/Servo%20motor%20control%20by%20PLC%20programming.html>, 2011)

Servo motors can work with external encoder, linear scale by courtesy of their internal full close loop. Linear scale is a feedback device that is as shown in Figure 3.9. Similar to encoders, these devices send the signal that is caused by the change on the position of motor shaft, to servo driver. As the most important difference between encoder and linear scale, in opposition to rotary encoder, linear scale is not coupled with motor shaft, linear scale senses the change on mover stages of linear mechanisms.

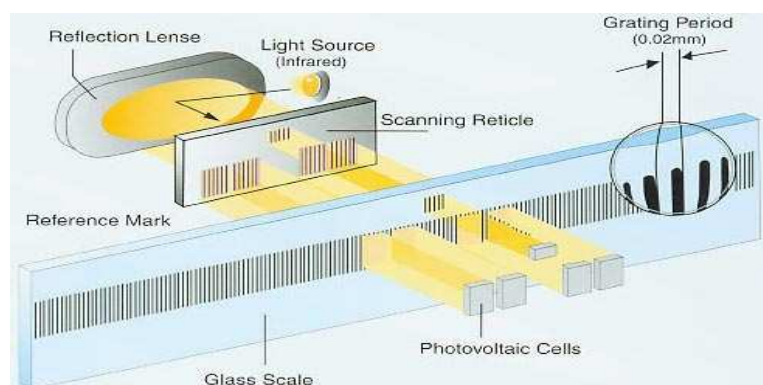

Figure 3.9 Linear scale working principle (<http://www.gobizkorea.com/blog/ProductView.do?blogid=dongsahn&id=800485>, 2011)

3.1.1.2 PLC Selection

In classical control systems, switching components were composed according to a program and circuit diagram. In this case, every change in program and circuit diagram causes modifications on connections and components. This problem affects the cost and time that are spent for control circuit. PLC (programmable logic controller) that was developed to solve these problems, was firstly manufactured in the late 1960s. First PLC that was called as Modular Digital Controller (MODICON) was introduced to american car manufacturers by Bedford Associates (Bedford, MA) Company.

The other companies introduced their computer based controllers in those years but MODICON 084 placed to people's memories. At the present day, PLC and expansion module sizes smaller than the sizes of first controllers. PLC and expansion modules that are used in today's automation systems are as shown in Figure 3.10.

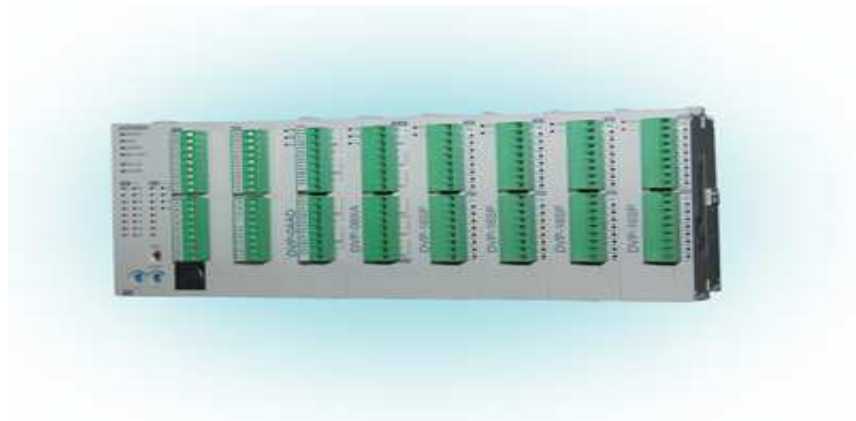

Figure 3.10 PLC and expansion modules (http://www.fastltd.net/sv_serisi-455_tr_cd.htm, 2011)

According to PLC diagram that is shown in Figure 3.11, there are 4 main parts in order to use PLC. Input modules take the signals that come from sensors. These signals are sent to CPU (central processing unit). Input signals are processed with the program commands that were sent by programming machine. Finally CPU sends the output data to output modules according to program conditions on CPU. A Programmer who uses the programming machine to send commands to CPU of PLC must use some special program languages as Ladder, FBD, STL. Many current PLC's can work with all these programming languages but the more programming language is simple, the more technique members make and understand PLC programs easier. Therefore Ladder diagram as the simplest programming language is preferred in PLC programming. (Maslar, M., 1996).

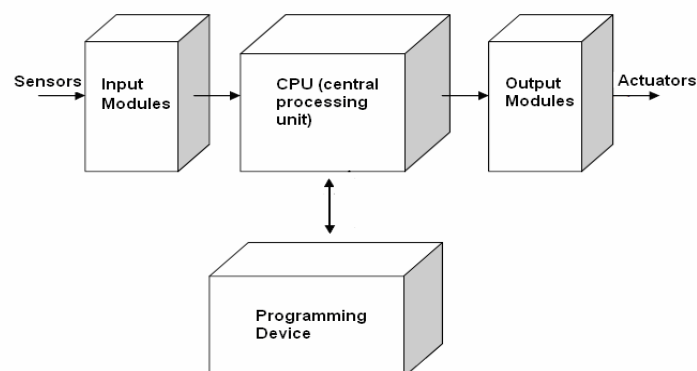

Figure 3.11 PLC structure

There are some criterion such as ram capacity, processing speed, quantity of special modules and memory bits, property and quantity of communication ports. Ram capacity of PLC identifies the maximum command quantity on PLC program and a wide Ram capacity is an obligation for advanced control systems. (Vieritz, H. & Yazdi, F. & Schilberg, D. & Jeschke, S. & Gohner, P. , 2011)

Speed is one of the most important property of PLC. Processing speed of CPU identifies the scanning time of whole PLC program. The more CPU processing speed increase, the more PLC directs the outputs according to input signals fast. In this case, processing speed is a big advantage for wide programs and prevents the faults that depend on delays of PLC output signals. (Peshek, C.J. & Graham J. , 1993).

According to system that is PLC used in, some special modules can be desired as HSC (high speed counter), pulse generator etc. In addition, this is an advantage for a PLC to have wide range for expansion digital and analog modules. Quantity of special memory bits as timers, counters etc. is also a factor to prefer a PLC.

In an automation system, property and quantity of PLC communication ports is very important. Beside RS-232 serial port, there must be Ethernet, RS-485 etc. additional ports in order to use communication protocols as modbus, profibus etc.

According to criterions about PLC, Delta 28 SV type PLC was selected to use in automation system of JI silicone dispenser machine. We could prefer more advanced PLC's but it would not be economical. In addition to cost advantages of Delta 28 SV PLC. General specifications of Delta 28 SV PLC are as below:

- 16K Ladder logic program capacity
- 512 Digital input/output
- 4 pieces 200 kHz pulse generator output
- 4 piece 200 kHz high speed counter input
- 2 axis interpolation capability with servo motors
- Internal 16 DI 12 DO on CPU
- RS-232, RS-485, Modbus RTU/ASCII communication port
- NPN-PNP preference for inputs

- Relay-Transistor output preference for digital expansion modules

3.1.1.3 Operator Panel Selection And Control Panel

In automation systems information flow is wanted to be high between operator(user) and manufacture lines or machines. All parts of machines and manufacture lines must be controllable and observable by operator because of their structure, PLC is closed to operator interferences. Since an information flow must be provided between operator and automation systems, firstly this requirement was provided with the equipments as button, lamp. However, for the equipments such as button and lamp, a control panel that is as shown in Figure 3.12 must be composed.

It can be said that control panel is uneconomical when consider its data transfer capability and the cost of the equipments on it. In addition to make a change on control panel is very hard, for example if we want to add even a button to control panel, we will make a new hole and wiring for only one button. (*Operatör paneller*, 2007).



Figure 3.12 Control Panel

In order to provide the control of automation system by operator, operator panel that is called as HMI (human machine interface) at the same time, was developed. The most important basic specifications of these devices are as below:

- Alarm messages that were sent by PLC can be seen on HMI
- Many parameters can be sent to PLC with recipe at once.

- Manual controls of machine can be done on HMI
- Operator panels provide to users ease of using and programming
- Operator panel can communicate with temperature controllers, motor drivers etc. industrial control devices without using PLC with its communication ports.

Delta operator panel that is as shown in Figure 3.13, has all the basic specifications above and was selected to use in automation system of JI silicone dispenser machine.



Figure 3.13 Operator panel of JI silicone dispenser machine

5.6 inches Delta operator panel that was selected for JI silicone dispenser machine has specifications as given below:

- ARM9 32-bit RISC CPU
- Arithmetic and logical processing capability with macro commands
- Serial communication ports as USB, COM1(RS232), COM2&COM3 (RS-485/RS-422/RS-232)
- TFT LCD monitor with 65536 color
- Recipe upload/download operations
- Online/Offline simulation function
- Alarm identifying
- Security level according to users and password function

Control system of JI silicone dispenser machine that is as shown in Figure 3.14, was assembled with selected PLC, HMI and Servo motor sets.



Figure 3.14 Control system of JI silicone dispenser machine

(ASD-A2 Series User Manual, 2011)

3.1.2 Sensing Equipments Selection

In sensing equipments subsection, according to usage places and purposes of the sensors we tried to select optimal sensor types. Industrial sensors such as capacitive, inductive, limit sensors etc. were investigated comparatively. Industrial sensing equipments that can be used in JI silicone dispenser machine are mostly proximity and safety sensors. Proximity sensors can detect the existence of target materials contactless. These sensors emit electromagnetic or electrostatic field and according to changes in detect field, sensors generate an analog or digital output signal. In industrial control systems the most preferred sensors are inductive, capacitive, magnetic, optical proximity sensors and lately reference sensor that is called optical limit sensor at the same time. (Omron electronics, 2005)

Optical proximity sensors detects according to changes on the light grade that falls on their detection components as photo transistor. Working principle of optical proximity sensors are based on two methods as detection the light that reflects from target material and detection the light that comes from a light source.

Inductive proximity sensors detect the metals. They provide an economical solution to sensing requirements of industrial machines. Inductive proximity sensors that are have a great resistant against to heat, electrical noise and water. Magnetic proximity sensors detect the changes in their magnetic field. They are used to detect the magnets that were placed on moving parts of the machines, working only with magnets prevents the effects of metal parts on sensor. (Sensörler ve transdüserler. , 2007).

Capacitive proximity sensors are also contactless sensors that are used in detection of metallic and nonmetallic materials with an adjustable detection field. Capacitive sensors have a great resistant against to dust and water but their sensitivity and accuracy are not reliable enough to use in most industrial applications.

The sensors were investigated in detail in order to make the optimal selection for a safe control on JI silicone dispenser machine. In order to detect the existence of LCD module, a proper sensor must be used on module carrier mechanism and LCD module delivery tables. Since the target material is a LCD module, capacitive and optical proximity sensors were investigated. Although the detection distance of capacitive sensors is adjustable, it can be very dangerous to use the capacitive proximity sensors that have lower sensitivity and accuracy, in sensing of LCD module that is a high cost and fragile material. Instead of capacitive proximity sensor, an optical sensor can detect LCD module. Keyence FSV 11 optical proximity sensor that is as shown in Figure 3.15, were used in detection of LCD modules.

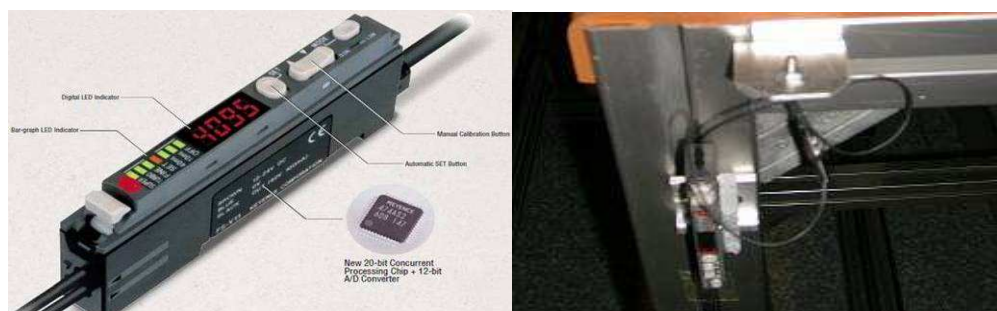

Figure 3.15 FS-V11 optical sensor on lcd module delivery table (<http://egurcay.wordpress.com/2011/04/12/disli-cark/>, 2011)

In order to detect motions of linear mechanisms and rotational motion mechanism, inductive proximity sensor or optical limit sensor can be used. Both of these sensor types are widely used in position detection in industrial automation systems but if we consider possibility of positioning faulty, optical limit sensors are better than inductive proximity sensors to use for high speed machine parts. Therefore all of the motion control sensors were selected as optical limit sensors.

In optical limit sensor that is as shown in Figure 3.16, there are two main components as light source and photo transistor receiver. Light source sends the light to receiver continuously and if any material for example a slim metal pin cuts the light, photo transistor detects the change on light, and sensor generates a digital output signal. Limit sensors are mostly manufactured in normally closed form. By courtesy of this method, a possible problem that occurs on sensor can be detected when sensor output signal becomes OFF. A pin on motion mechanisms is used to provide position detection of mechanisms by sensor.

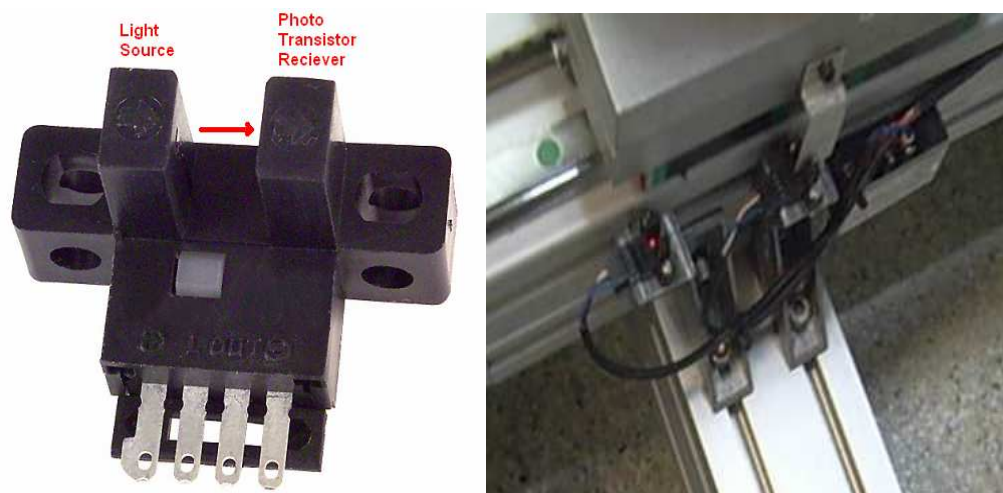

Figure 3.16 Working principle of optical limit sensor (<http://octopart.com/ee-sx671-omron-1317>, 2011)

The warning leds and safety sensors should be selected with appropriate sizes and also they should be placed appropriate points. Safety area sensors that are as shown in Figure 3.17, detect any passing into the working area of machine while mechanisms are moving in automatic mode of machine.

In JI silicone dispenser machine and JI bonding line, safety area sensors and warning leds especially are used in the points that have a possibility about collision of mover mechanisms and possibility about personnel injury.

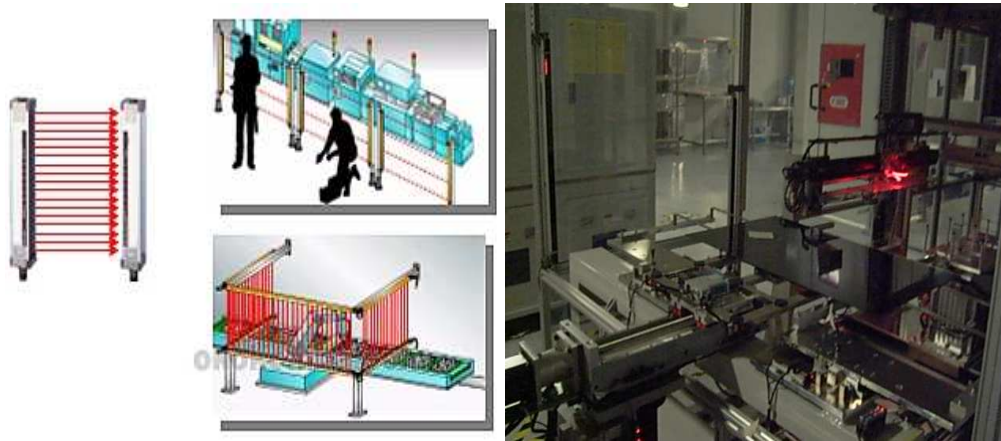

Figure 3.17 Safety area sensor usage (<http://www.okokchina.com/p/zz-Other-Security-Safety/Laser-Sensor-and-Laser-Area-Sensor-171291.html>, 2011)

3.2 Wiring Project And Connections

In this subsection, wiring project program details and general wiring principles were mentioned. In PLC connection and servo driver connection sub-sections, cabling methods used in PLC and servo driver were explained.

After the selection of all industrial automation equipments, the wiring project of JI silicone dispenser machine was drawn. Wiring project can be drawn with several 2 dimensional drawing programs such as Autocad. However, the drawing programs that have a library with industrial automation equipments images that were specified with international standards, are mostly preferred in order to make wiring projects. The most popular programs can be counted as Eplan and Cofaso. The important point while making the wiring project with these programs is to obey international wiring project rules. IEC (international electronic commission) standards are the most used standards in wiring projects. The wiring projects that we made by obeying the wiring rules and standards provide a big convenience in possible fault detection. A page of JI silicone dispenser machine wiring project is as shown in Figure 3.18.

The whole wiring project that was prepared with Cofaso project program is as shown in Appendix 2. (Cofaso kullanım kitapçığı-sürüm 6, 2008)

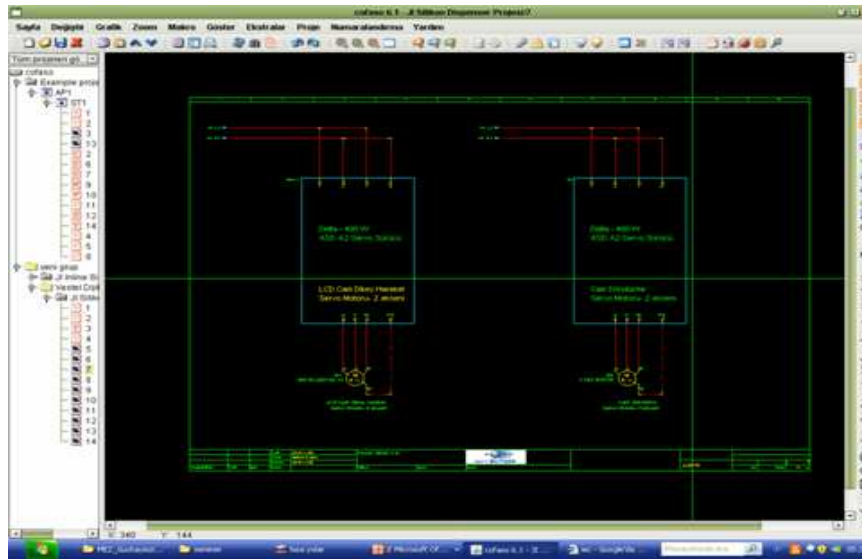

Figure 3.18 A page of JI silicone dispenser machine wiring project

After we completed the wiring project, we have executed the cabling process. In cabling process, according to cable connections specified in wiring project basic wiring principles and operations such as numbering of the cables and determination of cable types used in both main panel and remote equipments, were mentioned. The basic principles that should be considered in cabling process of JI silicone dispenser automation system can be explained as below:

- Cables from main panel to remote equipments are carried in cable channels that are shown in Figure 3.19.



Figure 3.19 Cable channel between main panel and remote equipments

- In order to collect the cables on motion mechanisms flexible cable channels must be used. In addition to flexible channels, cables pass through these channels must be resistant for continuous bending and twisting. The flexible cables on motion mechanisms of JI silicone dispenser are placed in flexible channels that are as shown in Figure 3.20.

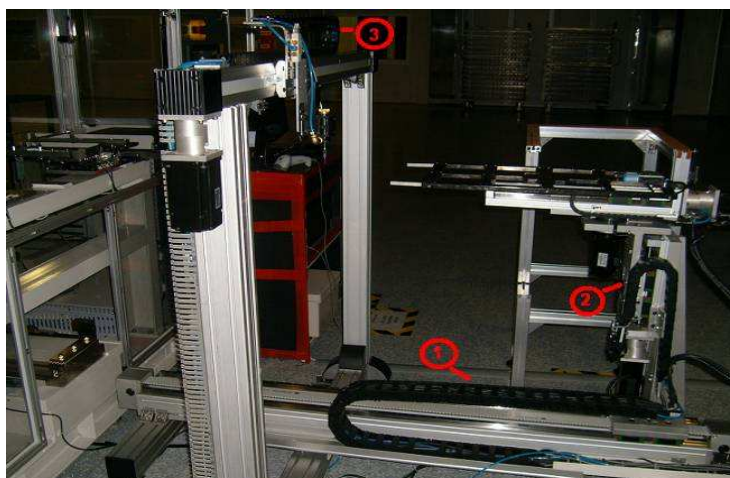

Figure 3.20 Flexible cable channels of JI silicone dispenser machine.

- In assembly process of fiber optic cables, fiber optic cables of fiber optic sensors such as FSV 11 must be cut with fiber optic cable cutter material. All cables must be connected in a single piece. Although the electrical insulation of addition points is made well, cables that are combined by adding the little cables are not preferred.

- Communication cables of JI silicone dispenser machine were selected as shielded cable. Communication data on these type of cables can be transmitted safer than the cables without shield.

- Devices in main panel must be placed with specified intervals in order to prevent the effects of temperature on devices. Minimum placement distances for Delta servo drivers are shown in Figure 3.21.

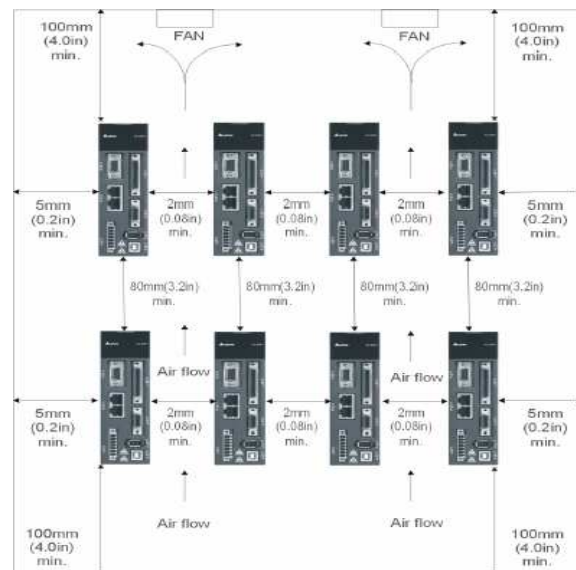

Figure 3.21 Minimum placement distances for Delta servo drivers (ASD-A2 Series User Manual, 2011)

- Cable colors were preferred as red for +24 V cables, blue for 0 V cables and for the power cables; brown for 220 V phase cables and blue for neutral voltage cables were selected.

- We worked according to all wiring standards and rules. It will be advantage for error detection in wiring.

3.2.1 PLC Connections

Almost all the plc types require 24 V DC power supply for its CPU and expansion modules.

As we remember from PLC selection section, PLC with internal input-output points and 4 input-output expansion modules were selected. +24 V output terminal of DC supply was connected to common S/S terminals of PLC and expansion modules. In this case, input terminals of PLC and digital expansion modules become to work with 0 V DC. Since all of the inputs terminals of PLC and expansion modules support 0 V DC signal, all of the input signal suppliers as sensors and buttons should be NPN type with 0V DC output. This terminal form that requires 0V DC to input terminals, is called as “SINK” and is as shown in Figure 3.22. (Plc ve montajı , 2006)

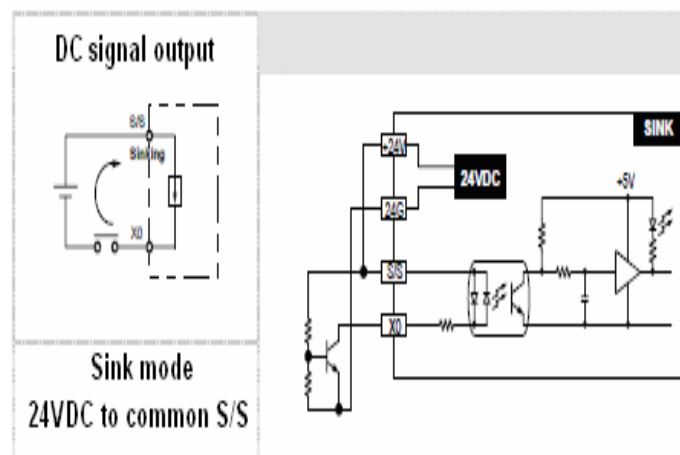

Figure 3.22 Digital signal input to PLC and expansion modules
in sink form (Delta 28 sv plc, 2011)

If we want to get digital output signal from PLC and digital expansion modules, 0V DC terminal of DC supply is connected to common C terminals of PLC and expansion modules as shown in Figure 3.23. In this case, output terminals of PLC and digital expansion modules become to work with 0 V DC. Since all of the outputs terminals of PLC and expansion modules support 0 V DC signal, all of the devices that are controlled with PLC output signals should work with 0V DC.

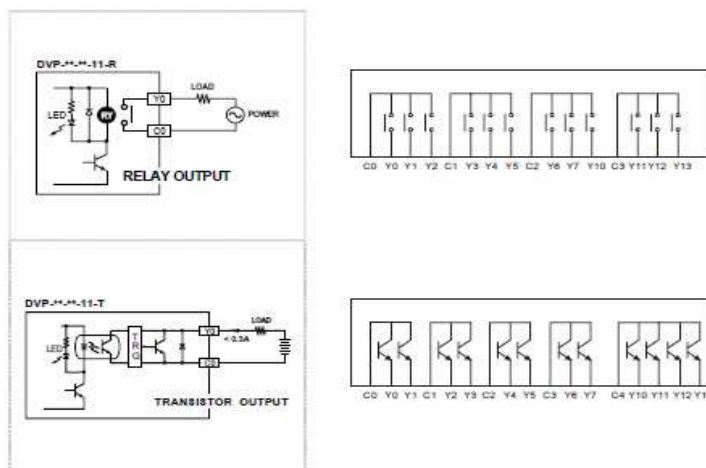

Figure 3.23 Digital signal output to PLC and expansion modules

Delta 28 sv plc, 2011)

3.2.2 Servo Driver Connections

Delta servo driver has several connectors that are as shown in Figure 3.24 but for our application 5 basic connectors as CN1,CN2,CN3, driver power input, motor power output are used effectively on servo driver. CN2 connector is used to get signals from internal rotary encoder. CN3 connector is used as communication port and this connector supports several communication types as RS 232, RS 422 and RS 485. In driver power input, 220 V AC power is applied to driver with R, S, T and L1C, L2C terminals. In motor power output, servo motor power is supplied with U, V and W phase terminals.

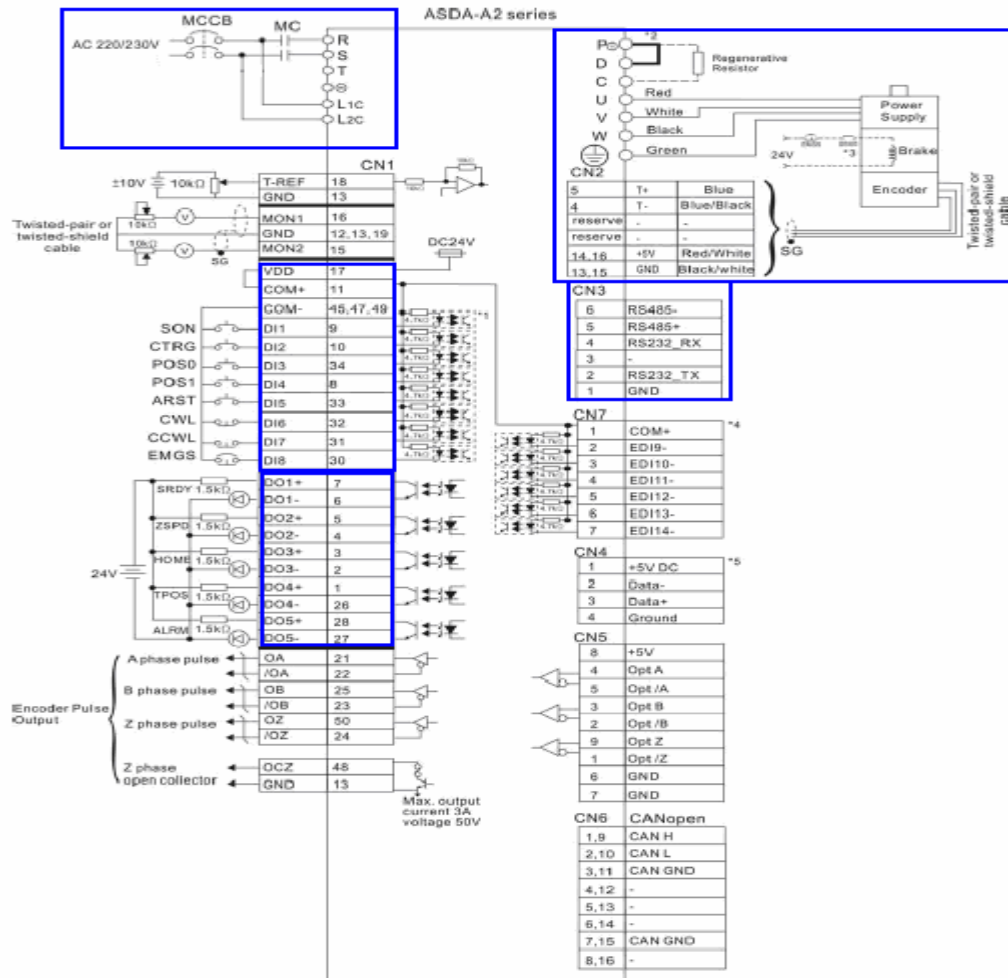

Figure 3.24 Delta servo driver connector structures (ASD-A2 Series User Manual, 2011)

CN1 connector is used for direct command transmission between PLC and servo driver. In CN1 connector, there are 8 pieces input terminals that are connected to PLC output terminals. PLC uses these terminals to lead the motion of servo motor. These 8 input terminals are used to get PLC commands as driver activation, motion start pulse, position definition, safety conditions etc. There are 5 pieces output terminals that are connected to PLC input terminals. These 5 output terminals are used to send servo motor data to PLC as positioning status, reference operation status etc. CN1 connector pin sequence is as shown in Figure 3.25.

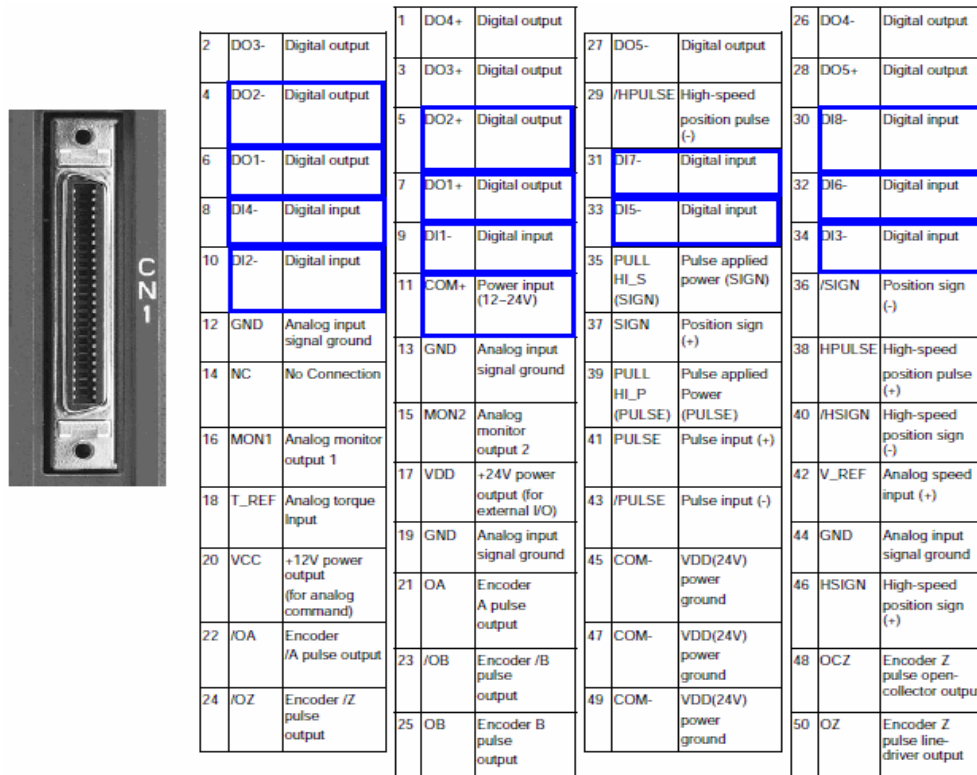

Figure 3.25 CN1 connector pin sequence (ASD-A2 Series User Manual, 2011)

Main panel contains PLC and expansion modules, fuses, servo drivers, terminals, relays, cable channels and cables. Firstly power cables is connected to main panel by main panel power switch then 220 V phase cable is distributed to servo drivers and DC supply. DC supply is connected to all equipments that work with 24V DC voltage such as PLC, sensors etc. When we do all of the connections in main panel, it becomes as shown in Figure 3.26.



Figure 3.26 Main panel general view

3.3 Software

In software section, programming details of control devices in JI silicone dispenser machine such as Operator panel, PLC and servo drivers were explained. In automation systems software and parameter adjustment process of PLC, HMI and motor drivers are specific a subject. Control system of JI silicone dispenser machine firstly depends on the commands from operator panel. Operator defines the products properties on HMI then sends the data about defined LCD module type. PLC processes the LCD module data in its program and then sends the commands to servo drivers. Servo drivers execute always the same continuous loop for each model. The difference that is change for each model is speeds and positions of mechanisms and also the time. Industrial automation system command direction is as shown in Figure 3.27.

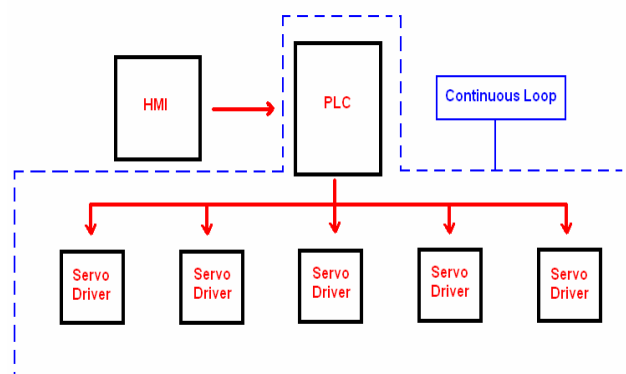

Figure 3.27 Automation system command direction

3.3.1 PLC Programming

In this section, PLC program configurations, symbol table settings, automatic operations diagram, step method details were explained. In a PLC program, before all of the operations communication adjustments are done. Communication protocol details as com port, data length, quantity of parity bits, quantity of stop bits, baud rate and station address are defined in communication settings window that is as shown in Figure 3.28.

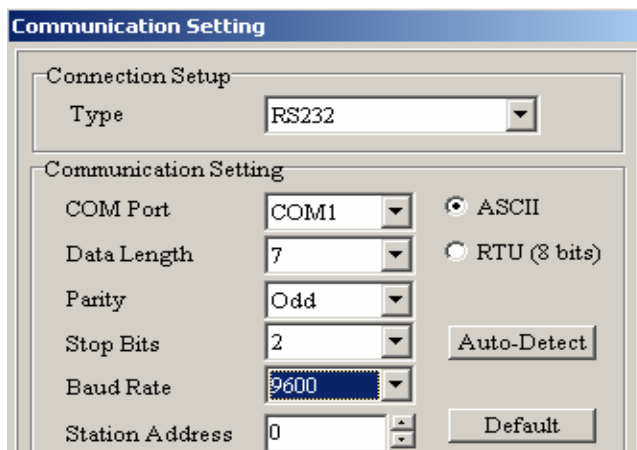

Figure 3.28 Plc-pc communication settings

Symbol table that is the second step of PLC programming, contains input-output names and their definitions that were specified by programmer. Definitions in symbol table were created as abbreviations. The definitions in symbol table helps to programmer to remember the program in future and helps the other programmers who want to understand PLC program. If we give an example to the definitions in PLC program of JI silicone dispenser machine; input X4 was defined as “btn_sys_auto”. It means: button that is connected to X4 input terminal of PLC is used to change the machine mode from manual to auto. Symbol table of PLC program is as shown in Figure 3.29.

State	Identifiers	Device	Comment
*	btn_emg1	X0000	btn_emg1
*	btn_emg2	X0001	btn_emg2
	btn_home_pos	X0002	btn_home_pos
	btn_sys_bgn	X0003	btn_sys_bgn
*	btn_sys_auto	X0004	btn_sys_auto
	btn_sys_man	X0005	btn_sys_man
	btn_sys_cont	X0006	btn_sys_cont
	btn_sys_ref	X0007	btn_sys_ref

Figure 3.29 Symbol table

3.3.1.1 Automatic program blocks on plc program

Industrial machines are mostly used in manufacturing sector. Because of the speed factor in manufacturing sector, machines are not stopped except the maintenance and error conditions. In addition, machines must work independent from human factor as much as possible, this is called as full automatic principle. PLC program of JI silicone dispenser machine works according to continuous loop with automatic principle. JI silicone dispenser machine executes carrying and siliconizing operations and places LCD module on LCD module delivery tables automatically. Tester personnel or any person are not a factor in machines automatic operations. Therefore a continuous loop algorithm that repeats itself automatically, was developed for JI silicone dispenser machine. PLC automatic operations diagram is as shown in Figure 3.30. (Basile, F. & Chiacchio, P. & Gerbasio, D. , 2010)

In PLC automatic operations diagram 3 basic conditions are shown. According to diagram, to execute the automatic operations safety conditions, home position conditions and program step conditions must be provided. In other words, automatic program steps start when the machine parts are in safe, in home position and motionless. PLC program executes automatic operations continuously with the support of these conditions.

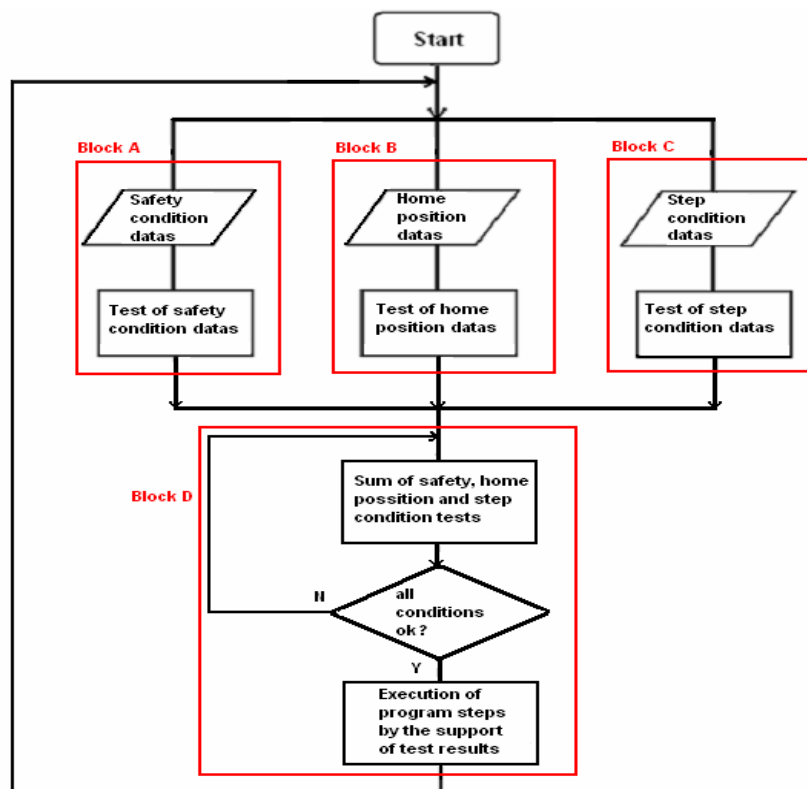

Figure 3.30 PLC automatic operations diagram

In Block A that was shown in Figure 3.31, signals of 2 emergency stop buttons and limit sensor data on mechanisms of JI silicone dispenser were tested in PLC program.

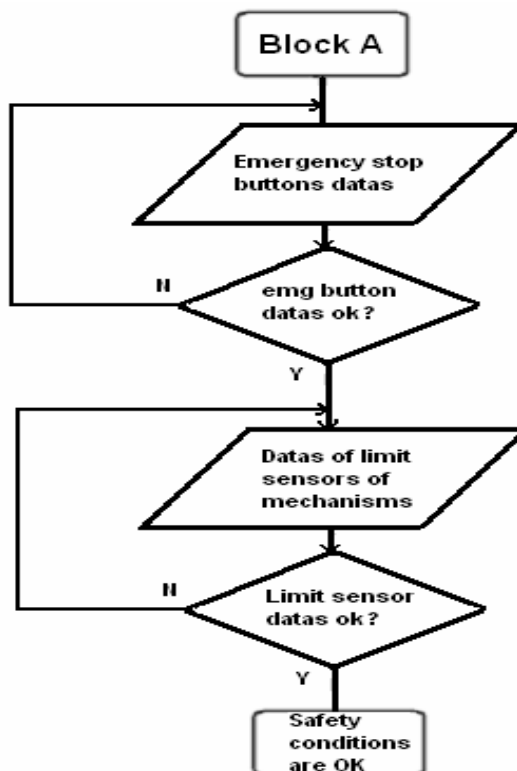

Figure 3.31 Safety conditions flow chart

Safety conditions are represented with a memory bit that is defined as “Safety ok” in Figure 3.32. “Safety ok” bit was composed with the data that are come from emergency stop buttons and limit sensors. In this case, safety condition can be provided in condition that all data from limit sensors and emergency stop buttons are ok. In following row, “Safety ok” bit was used to enable servo drivers. Any manual or automatic operations about servo motors can not be executed unless “Safety ok” bit is ON.

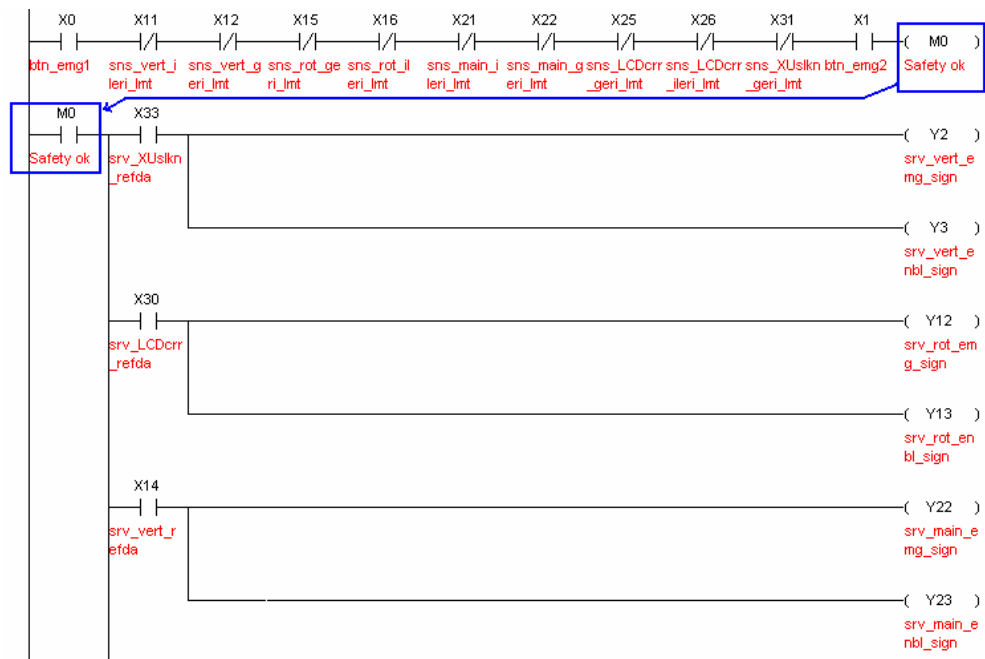

Figure 3.32 Safety conditions on plc program

In addition to “Safety ok” bit, reference data of each servo motor that came from servo drivers, are used to enable servo drivers successively. According to Figure 3.33, when “Safety ok” bit is ON, if the user press “reference button” on HMI 3 seconds, T19 bit that was named as “referans mühürü” becomes ON then it enables the servo driver of XU silicone mechanism. After T19 enables servo driver, it executes the reference operation of servo motor of XU silicone mechanism automatically. When servo motor of XU silicone mechanism completes the reference operation, servo driver generates a bit that was named as “srv_XUslkn_refda” become ON then this bit enables the servo driver of vertical motion mechanism. This sequential enable loop finishes when rotational motion servo motor completes its reference operation.

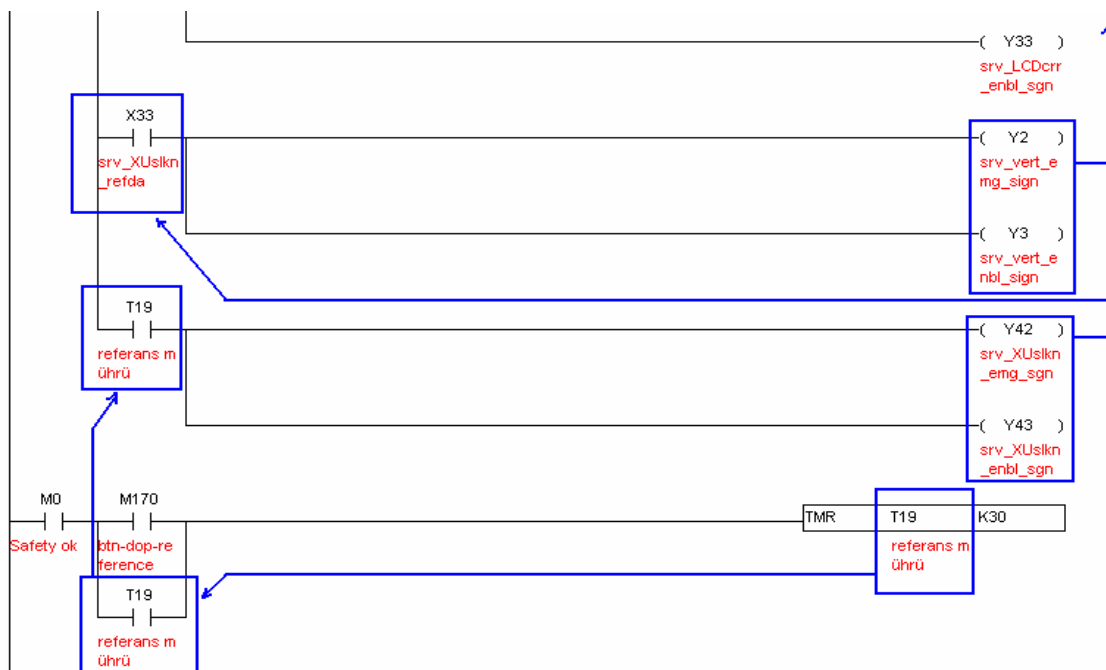

Figure 3.33 Reference operations on plc program

In addition to test for safety conditions, in Block B, home position conditions were also considered. Home position is the start position of automatic steps of PLC program. JI silicone dispenser machine executes the motions with a sequence and when all the moving parts complete their motions, machine is on starting position and can execute automatic loop again. In JI silicone dispenser machine, home position conditions of moving parts were detected with position sensors on the mechanisms. Home position conditions flow chart of JI silicone dispenser machine is as in Figure 3.34.

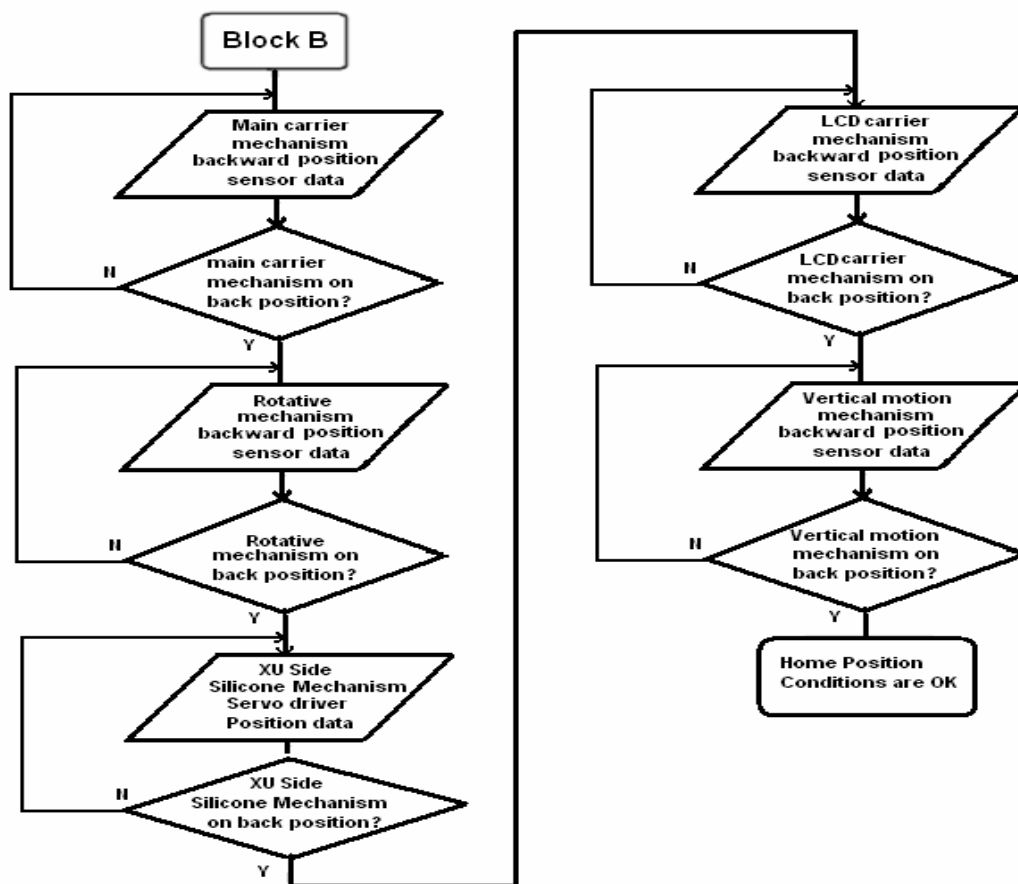

Figure 3.34 Home position conditions flow chart

In condition that “Safety ok” bit is ON, if all of the mover stages of mechanisms are ON, M3 that was named as “home pos” is ON. We use “home pos” as a starting condition for automatic steps. Home position conditions were placed on plc program as shown in Figure 3.35.

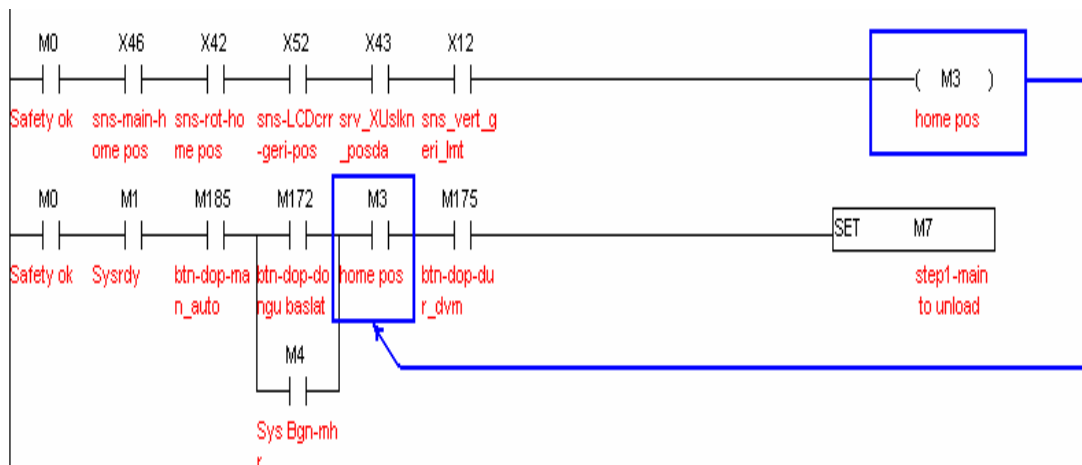

Figure 3.35 Home position conditions on plc program

In addition to test for home position conditions, in Block C that was shown in Figure 3.30, step states of automatic program were tested as in step conditions flow chart that was shown in Figure 3.36.

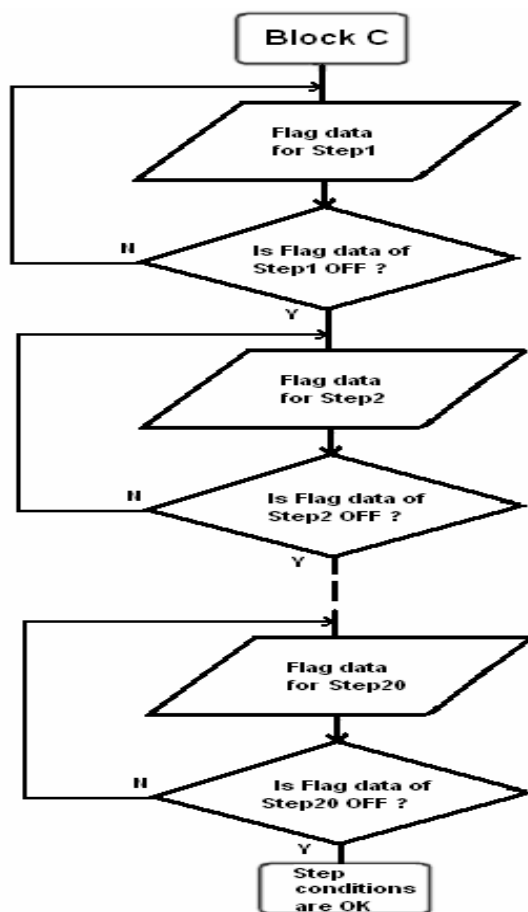

Figure 3.36 Step conditions flow chart

A memory bit that is called as “Sysrdy” is composed with automatic step data and it represents all of the steps status. Sysrdy is a caution incase users might start the automatic operations by mistake. By courtesy of Sysrdy, even we press start button while machine executes the operations, automatic steps does not start all over.

After we created the required tests for automatic steps such as safety conditions, home position conditions and step conditions. In Block D that was shown in Figure 3.30, we composed automatic steps. PLC program automatic steps can be explained with a flow chart as shown in Figure 3.37. (Davidson, C. & McWhinnie, J. 1997)

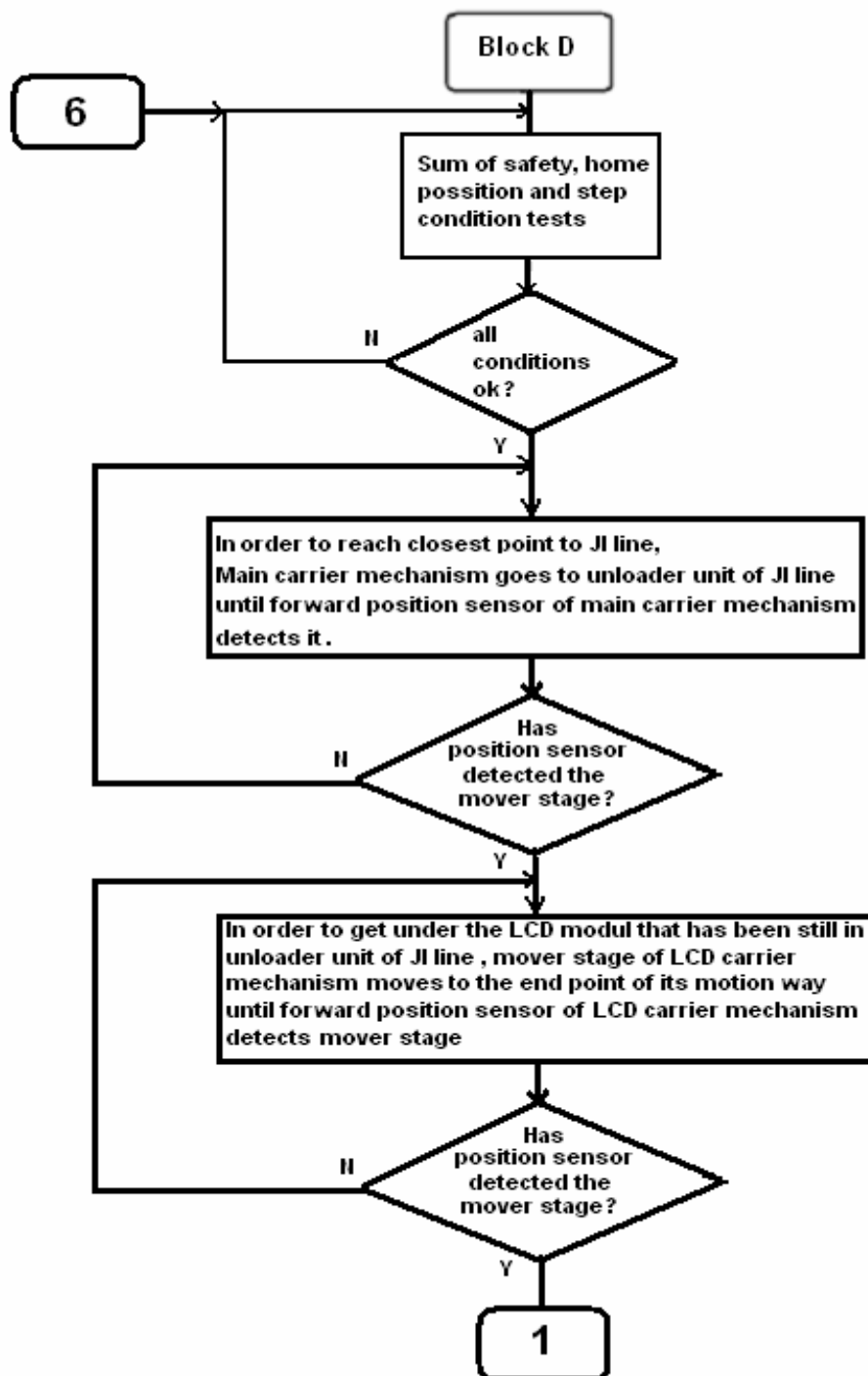

Figure 3.37 PLC program automatic steps

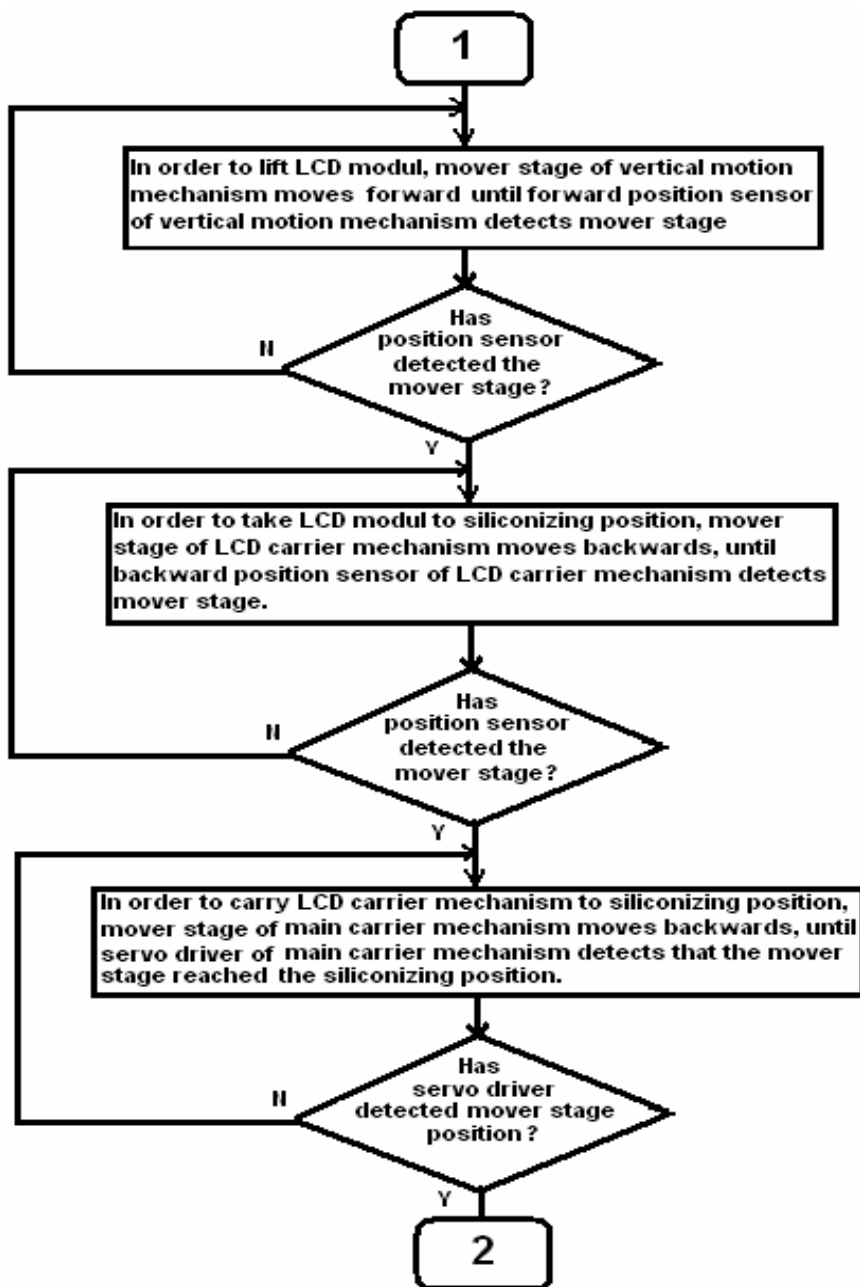

Figure 3.37 PLC program automatic steps (continue)

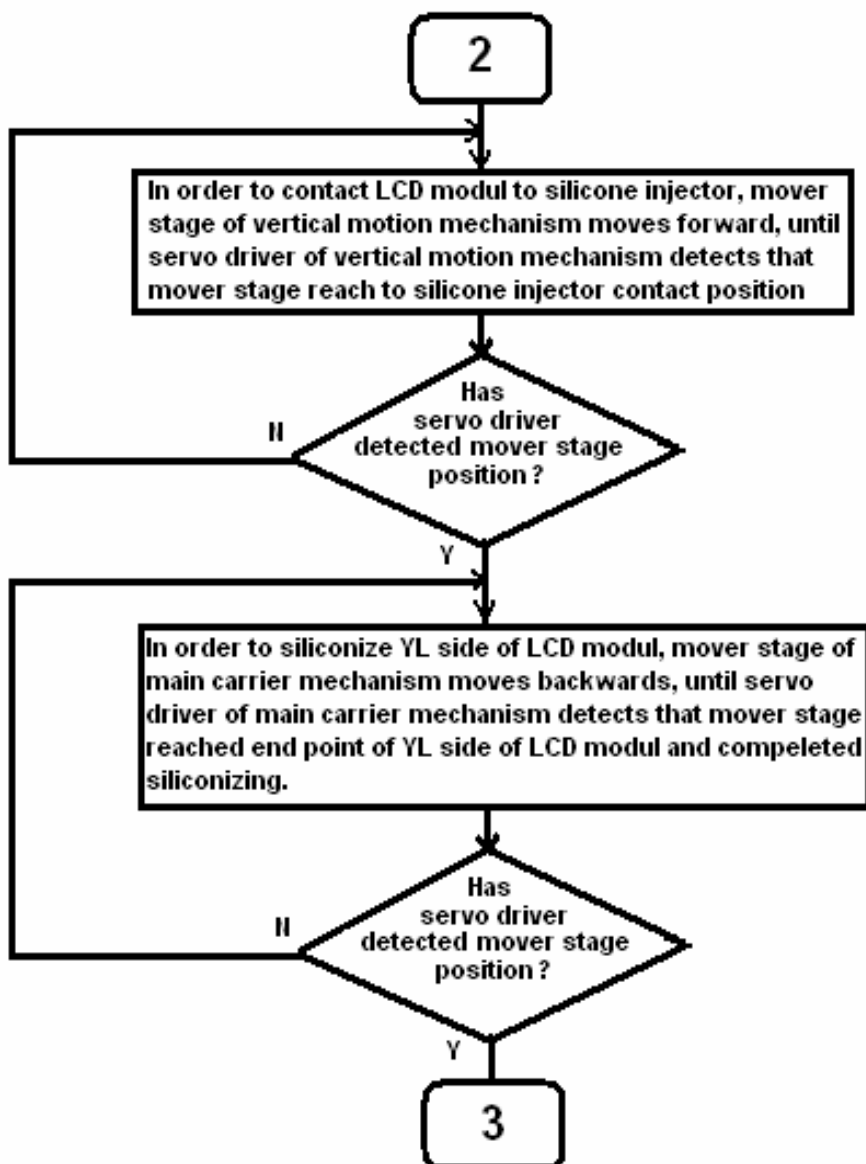

Figure 3.37 PLC program automatic steps (continue)

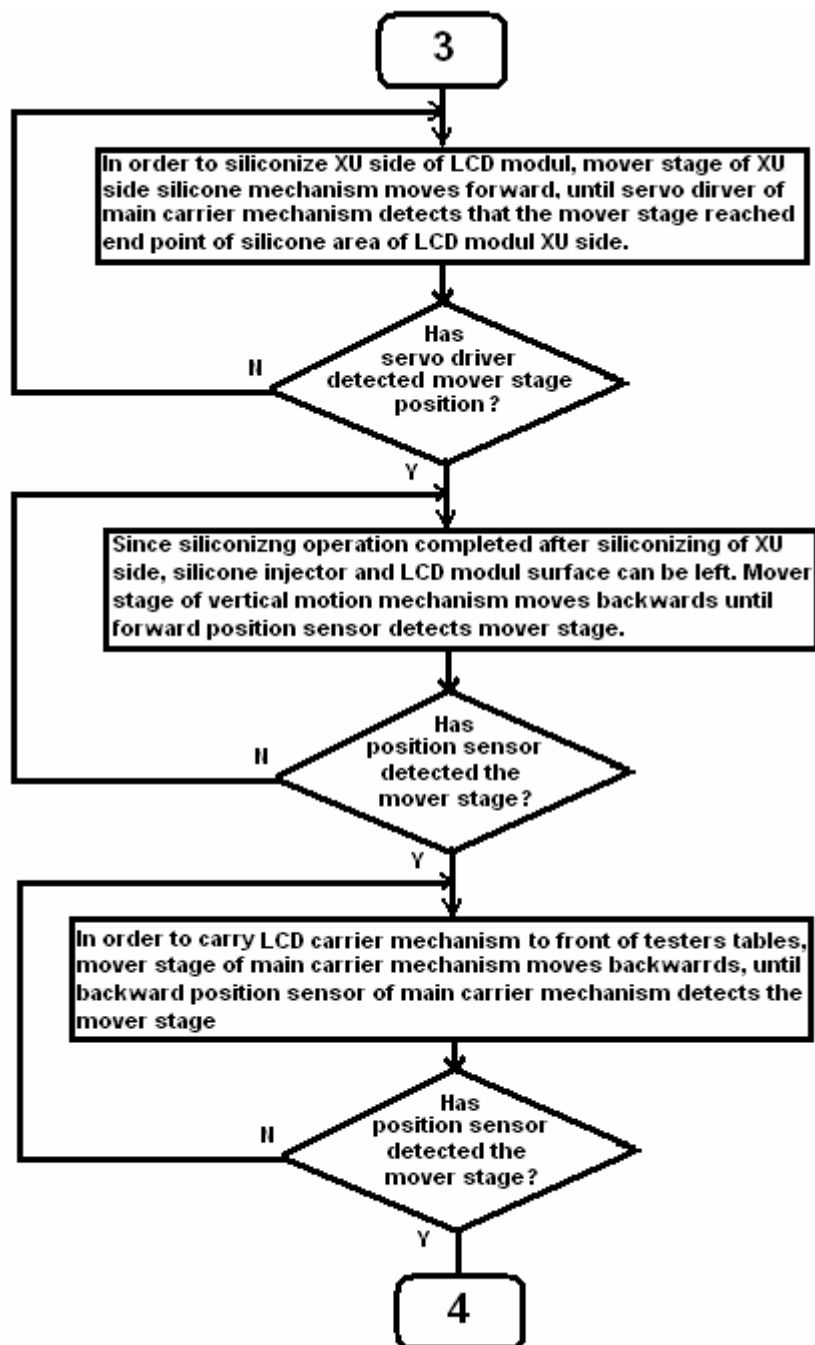

Figure 3.37 PLC program automatic steps (continue)

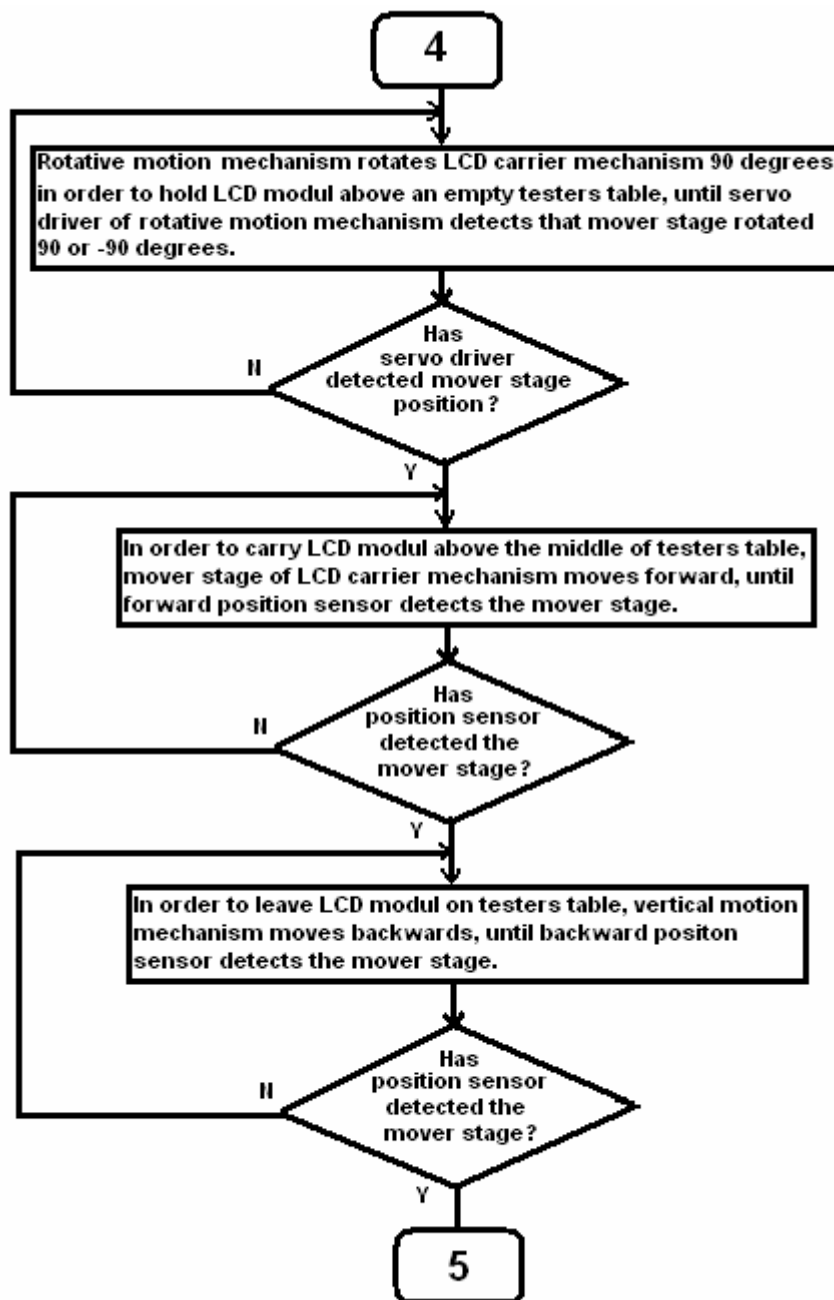

Figure 3.37 PLC program automatic steps (continue)

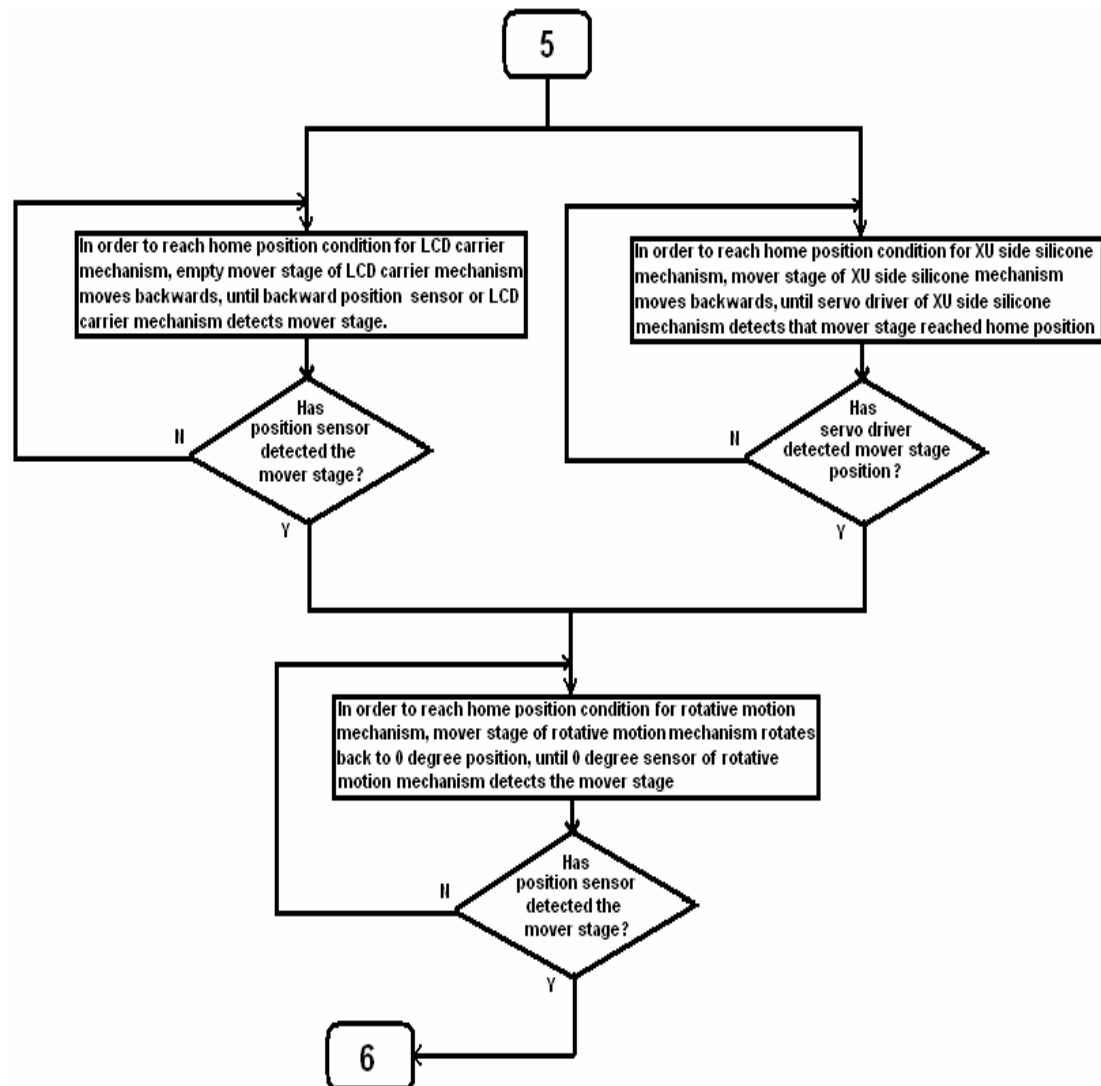

Figure 3.37 PLC program automatic steps

In creation of automatic step of PLC programs, programmers can use specific methods but “step method” is the most preferred method that is used for the software of machines work with continuous loop. Since JI silicone dispenser machine works with continuous loop, step method was preferred. Step method depends on separating the automatic operations of machines and main purpose is to compose PLC program easily and to make it more understandable. PLC program allows to start automatic operations according to the data of safety conditions, step conditions and home position as shown in Figure 3.38.

If the safety conditions, step conditions and home position are ok and the operator has pressed buttons of HMI such as “btn-dop-dongu baslat” that starts the loop, “btn-dop-dur_dvm” that allows paused steps to resume, and “btn-dop-man-auto” that turns the machine status to auto mode, M7 bit that was named as “step1-main to unloader” becomes ON and main carrier mechanism moves forward in order to reach unloader unit of JI bonding line.

Mover stage of main carrier mechanism goes on until it reaches the target position that we defined on servo driver but incase mover stage does not stop on target position because of high load of mover stage, we used a position sensor that was called as “sns-main-ileri pos”. In this case mover stage moves forward until the sensor “sns-main-ileri pos” detects the mover stage.

In addition, while mover stage of main carrier mechanism moves, backward position sensor of vertical motion mechanism should detect that LCD carrier mechanism is still on proper position in vertical. Finally if the user does not press the pause-resume button that was called as “btn-dop-dur_dvm” M8 that was called as “step2-LCDcrr forward” is set and at the same time, completed step that was represented with M7 (step1-main to unloader) is reset. By using step method, 15 steps of JI silicone dispenser were realized. The key point of step method is to determine the finish condition of related step and the caution conditions during the motion. All the conditions of any step are connected serially in PLC program so that step stops when any condition is OFF.

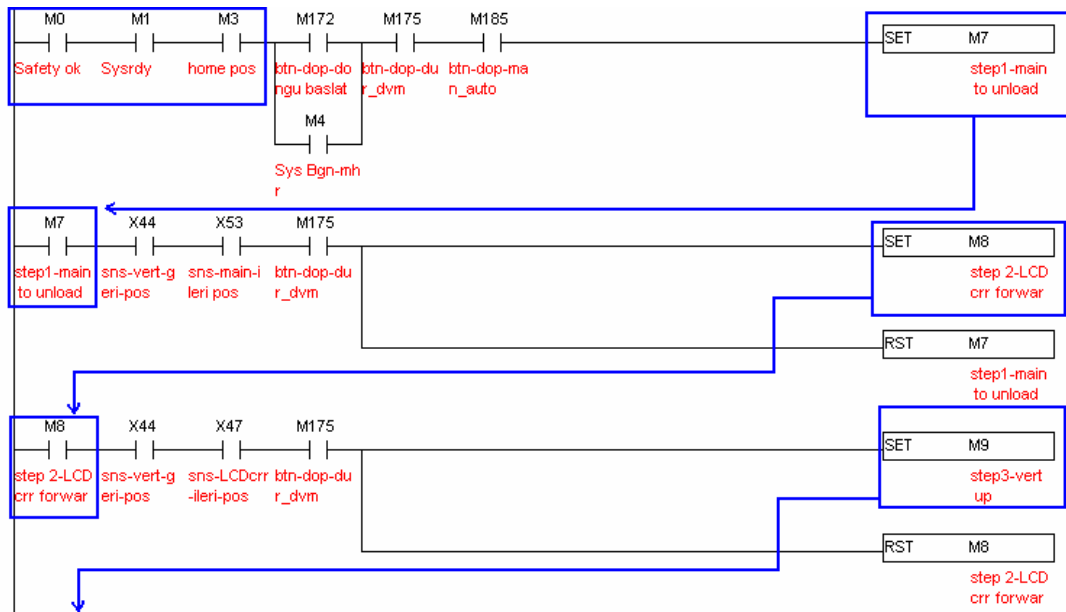

Figure 3.38 Execution of automatic steps with step method

Automatic operations of JI silicone dispenser machine were defined with 15 steps. Instead of composing PLC outputs from automatic steps directly, firstly virtual outputs were composed with memory bits. The purpose of composing virtual outputs is to use PLC outputs as multi. Virtual outputs represent only automatic steps but PLC outputs must represent both of manual and automatic operations. Composing the virtual outputs from automatic steps is as shown in Figure 3.39.



Figure 3.39 Composing the virtual outputs from automatic steps

Virtual outputs of automatic steps and manual operation commands were connected in parallel form as shown in Figure 3.40. According to Figure 3.40, there are 3 virtual output memories control one plc output. These virtual outputs belong to 3 different steps but all of them make Y7 that was named as “srv_vert_pos1_sign” ON. Y7 is one of a plc output defines a position to servo driver of vertical motion mechanism.



Figure 3.40 Composing of plc outputs with virtual outputs and manual commands

In PLC program of JI silicone dispenser machine, firstly the position definition commands “pos0 and pos1” were sent to servo drivers and then with a delay about 300 milliseconds the motion start pulses that were defined as “ctrq” were sent. This method prevents the mistakes in servo drivers about internal position addresses. Composing of servo driver commands is as shown in Figure 3.41.

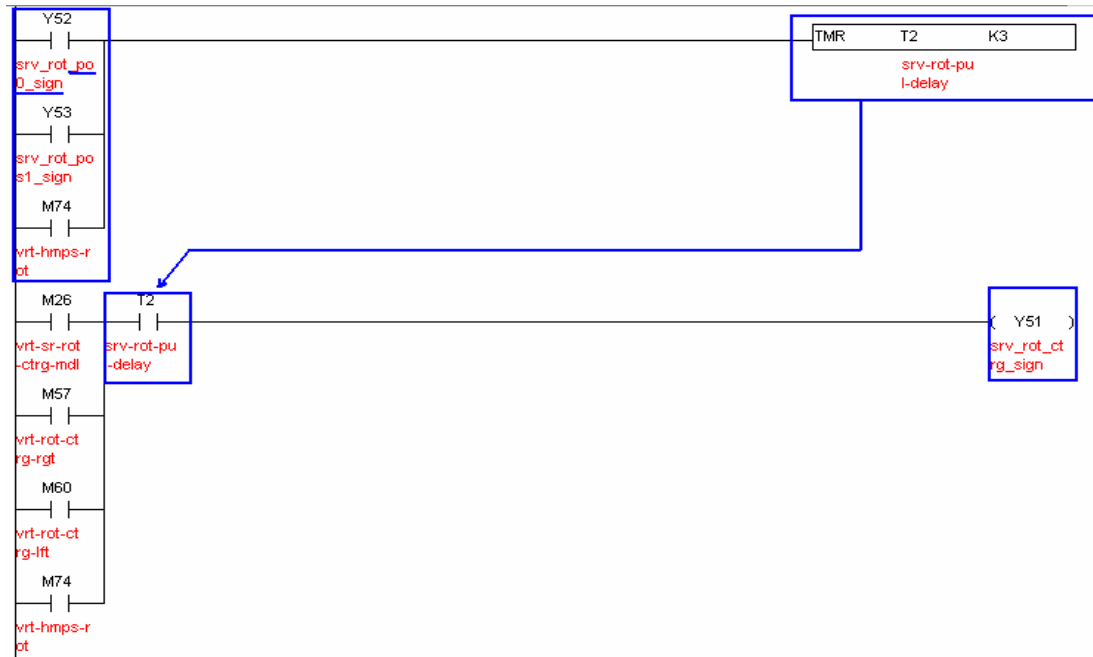

Figure 3.41 Composing of servo driver commands

3.3.1.2 Serial communication blocks on plc program

In order to provide a communication network between industrial control devices such as PLC, HMI and servo drivers several communication interfaces are used such as RS 232, RS 485, ethernet, usb. The differences among these communication interfaces can be counted as wiring, connector structure and max allowed communication distance. Therefore communication interfaces are not communication languages that are called as protocols mostly. For example, two people can talk in different methods as face to face and on phone. Regardless of method, these people must speak with same languages to make a conversation. If we consider this example for automation devices, the language is communication protocol.

RS 485 interface allows safer communication with longer distances and we preferred this interface in serial communication network between PLC and servo drivers. Serial communication connections of industrial control system are as shown in Figure 3.42.

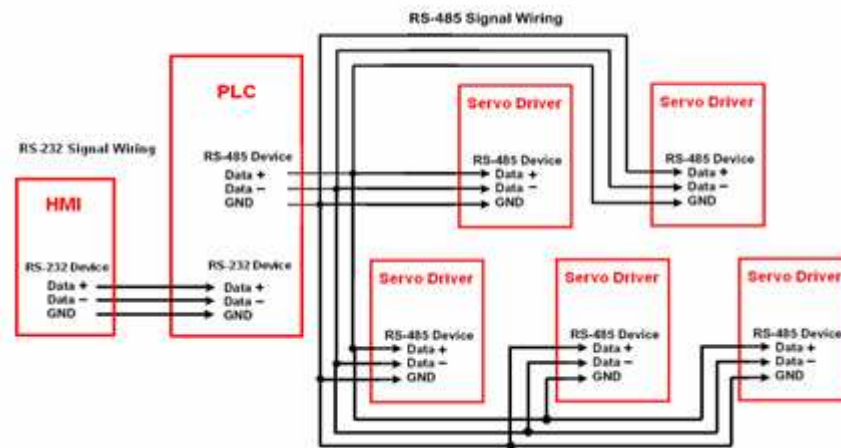

Figure 3.42 Serial communication connections of industrial control system

Modbus communication protocol that was used to communicate PLC and servo drivers, is one of the oldest communication protocol. Modbus protocol was developed by Modicon company in order to use for companies own PLC models in 1978 but this protocol became a standard in serial communication of industrial automation systems in time. At the present time, lots of industrial device manufacturers use modbus protocol in their automation devices beside with their own communication protocols as profibus, asi etc. In communication of automation system of JI silicone dispenser machine Modbus ASCII protocol was used in communication network between RS 485 port of PLC and CN3 connectors of servo drivers. In order to communicate with servo drivers, firstly modbus protocol parameters were set as shown in Figure 3.43. We entered a hexadecimal number “H86” into the register of “D1120” in order to define communication protocol as “9600-7-E-1”, it means PLC sends the data with the speed of 9600 bit per seconds and the data is composed with 7 bit as information bits and 2 bits as parity bits and 1 bit as stop bit. In order to define communication time out we entered a decimal number “100” into the D1129 register and in order to define PLC communication address we entered “1” into D1121 register. Finally we reset the communication steps from s1 to s5. Modbus communication settings were executed for only one scan. Modbus protocol parameters settings on plc program is as shown in Figure 3.43. (Modicon inc., 1996)

After we completed all the communication settings, PLC becomes ready to send the position and speed data to servo drivers. Serial communication starts when operator presses the button of HMI that was represented with “M100 bit” register on PLC.

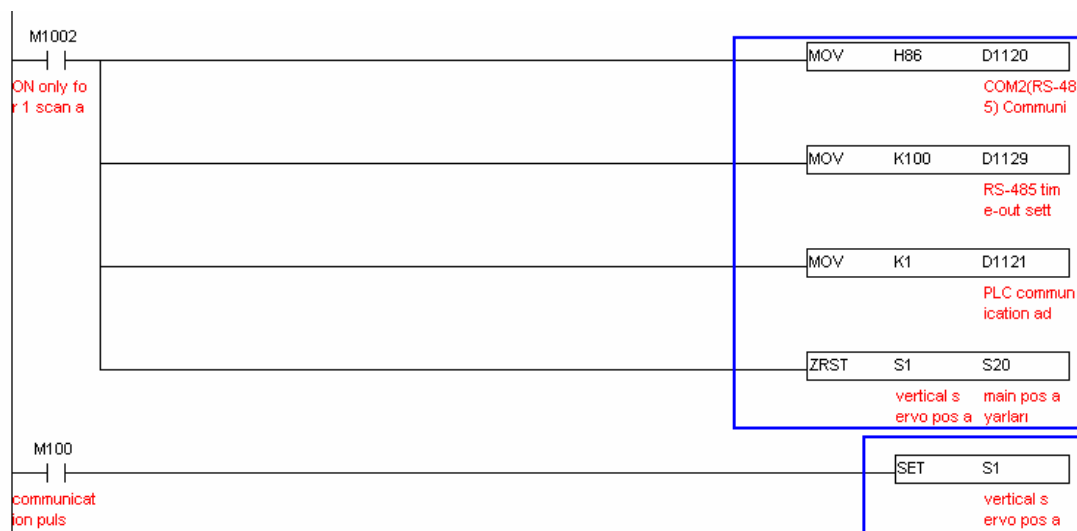

Figure 3.43 Modbus protocol parameters settings on plc program

After we set the “s1” register that represents the communication operations of servo driver of vertical motion mechanism, the command “MODRW” executes data transfer as shown in Figure 3.44. In “modrw command”, K2 represents the servo driver communication address and “K16” represents read-write function code and “H604” represents the position parameter address and “D300” represents the plc data address that we sent the position data from HMI and “K4” represents the position data length that is 32 bit.

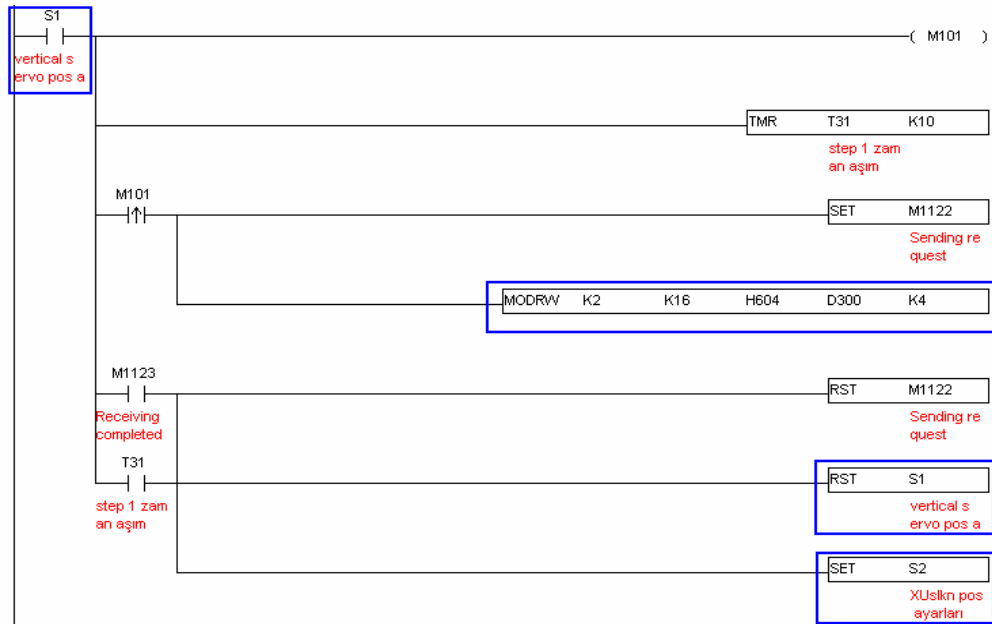

Figure 3.44 Position and speed data sending with modbus protocol on plc

PLC communicates with HMI by using RS 232 port. “M240” register was defined as “alarm message” address on HMI so this register was used to send alarm messages of automation system on plc. As we see in Figure 3.45, if the signal of any emergency button becomes OFF because of pressing on these buttons, plc enters “1” into M240 register. Since we define M240 register as alarm message register on HMI, an alarm message occurs on HMI display about emergency button status. Alarm message helps to operator to notice that the reason that stops the machine is caused by emergency buttons, not from any other equipment. If we release the pressed emergency buttons, plc enters “0” into M240 register and alarm messages on HMI disappears. Similar to emergency button alarm messages, in order to inform the operator we used limit sensor alarm messages for all limit sensors of mechanisms of JI silicone dispenser machine. As we see in Figure 3.45, if the signal of limit sensors of vertical motion mechanism that were represented with the registers “sns_vert_ileri_lmt” and “sns_vert_geri_lmt” becomes OFF because the mover stages pass the motion limits, plc enters “2” into M240 register. Since we define M240 register as alarm message register on HMI, an alarm message occurs on HMI display about limit sensors of vertical motion mechanism. Alarm message helps to operator to notice that the reason that stops the machine is caused by the signal of limit sensors of vertical motion mechanism, not from any other equipment.

If we solve the problem about limit sensors, plc enters “0” into M240 register and alarm messages on HMI disappear. Alarm message displaying is the same for the other mechanisms and operator can notice all the safety reasons and can solve these problems about any equipment in a short time.

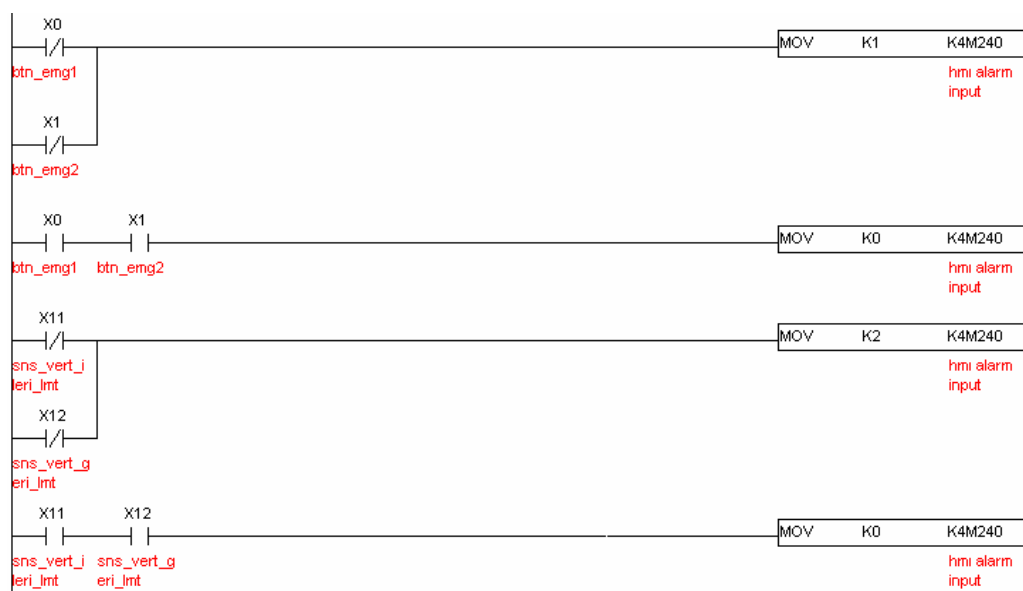

Figure 3.45 Communication blocks for hmi communication on plc

3.3.2 Operator Panel Programming

In this section, Screen editor HMI program configuration, communication, alarm and recipe settings were mentioned. Before all of the software details, communication settings were done in HMI. In order to reach a smooth and fast communication, base communication port of HMI was used to connect PLC. Communication interface and protocol are defined as shown in Figure 3.46.

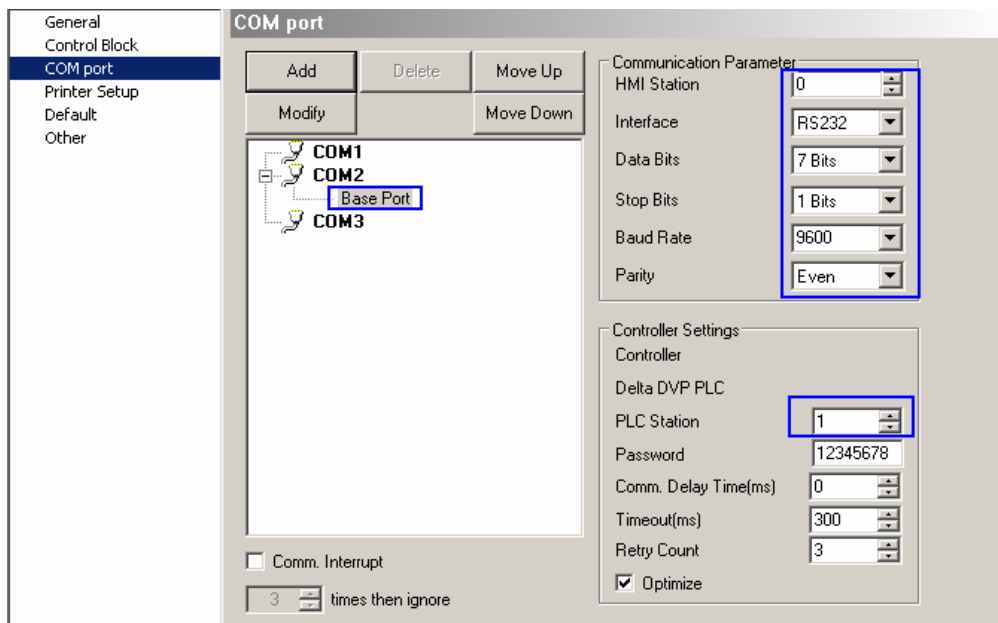

Figure 3.46 Operator panel communication settings

HMI that is used in JI silicone dispenser machine has 3 pieces com port. Since PLC uses its RS 485 com port to connect servo drivers, RS 232 port of PLC is available for HMI connection so Com2 port of HMI that is as shown in Figure 3.47 was used to data transmission with PLC. Therefore base com port of HMI is used in mode 1 that allows RS 232 connection.

COM1 Port (Flow Control destekler)

COM Port	PIN	Bağlantı RS-232
	1	
	2	RXD
	3	TXD
	4	
	5	GND
	6	
	7	RTS
	8	CTS
	9	

Not: Boş pin = Bağlantı yapılmaz.

COM2 ve COM3 Port

COM Port	PIN	MOD 1		MOD 2		MOD 3	
		COM2 RS-232	COM3 RS-485	COM2 RS-485	COM3 RS-485	COM2 RS-232	COM3 RS-422
	1			D+			TXD+
	2	RXD				RXD	
	3	TXD				TXD	
	4		D+		D+		RXD+
	5	GND		GND		GND	
	6			D-			TXD-
	7						
	8						
	9		D-		D-		RXD-

Figure 3.47 Operator panel com port selection table (dop b kullanım klavuzu, 2011)

Screen editor program is an HMI software that depends on programming with visual objects on monitor. JI silicone dispenser machine HMI software was crated with Screen editor program and the functions and the visual buttons were separated to 7 pages. The most important functions in HMI pages are to show alarm messages that came from PLC, to send the manual button commands to PLC with visual buttons and to send LCD module position data by recipe to PLC. In the first page of HMI program of JI silicone dispenser machine, there are texts that define the project and the company that we created the machine for. In addition, we placed the date and time displays and a visual button to pass following pages. The first page of HMI program of JI silicone dispenser machine is as shown in Figure 3.48.

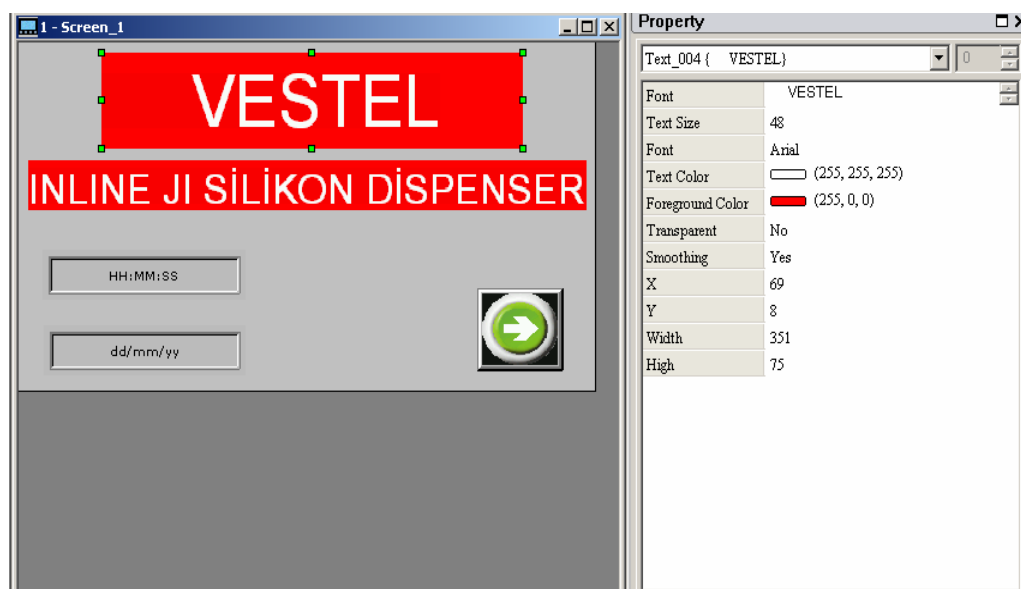

Figure 3.48 Screen editor program work page

In the second page of HMI program of JI silicone dispenser machine, there is an alarm message box. In control of JI silicone dispenser machine, alarm messages are one of the most important data group. PLC program sends the alarm messages that were created by PLC program and HMI displays the alarm messages according to the definitions in alarm setup window that is shown in Figure 3.49. In order to provide the detection of alarm messages by operator panel PLC addresses of alarm bits are defined in alarm setup window. Alarm messages that are generated by PLC are the limit sensor signals and emergency button signals.

As we remember from Figure 3.45, plc sends alarm messages with “mov” command that executes data transfer into “M240” register. We defined the “M240” register also in HMI in order to get plc signals that represent alarm messages. For example, when plc sends decimal “1” to M240 register, HMI displays “acil stop butonları basılı” that means “emergency stop buttons are still pressed” and when plc sends decimal “8” that is equal to binary “00001000” , HMI displays “XU silikonlayıcı limit sensörlerinde sorun var” that means “ there is a problem about the limit sensors of XU side silicone mechanism”.

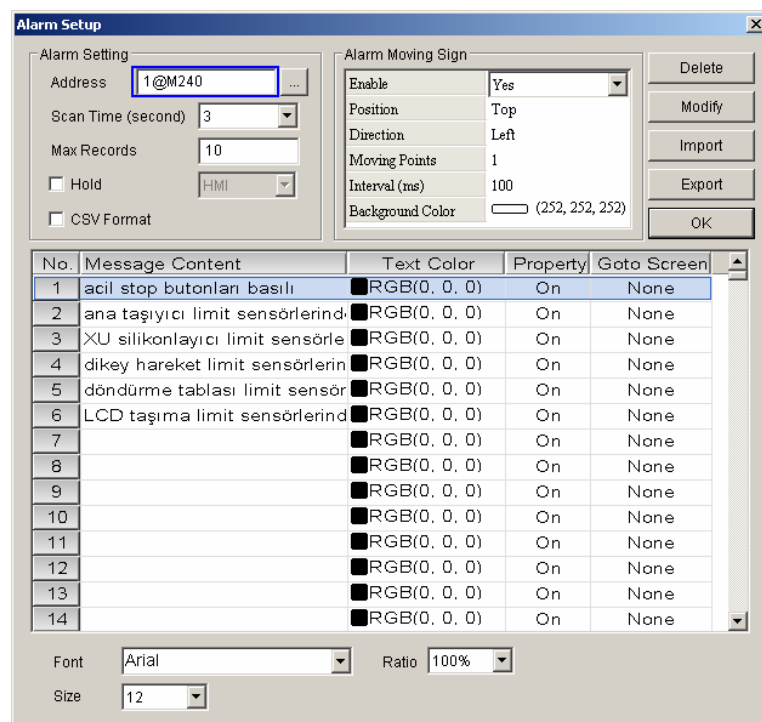

Figure 3.49 Alarm messages definitions in alarm setup window

In the third page of HMI program of JI silicone dispenser machine, there are manual control buttons that control some bit registers on plc program and also there are buttons for passing the previous and following pages. In order to create a visual button on HMI we mostly selected “momentary buttons” and a proper button symbol for it. For example, when we consider Figure 3.50, there is a button that was named as “referans aldırma” that we use to execute the reference operations of servo drivers. In property window of this button, we defined its “write address” as “1@M170”.

This definition means that when we the operator press on this button, M170 register of plc that was numbered with address number “1” becomes ON. We used this register in order to enable reference operations of servo drivers on plc. By using same assigning method for buttons on HMI, the other visual buttons of HMI defined for several operations such as “home pos yaptırma” button that executes home position operation and “döngü başlat” button that executes cycle start operation for automatic steps and “modül vakumu” button that activates vacuum on LCD module carrier mechanism and “silikon valfi” button that activates silicone flow from silicone injector and “duraklat-devam” buttons that executes pause and resume operations on automatic steps.

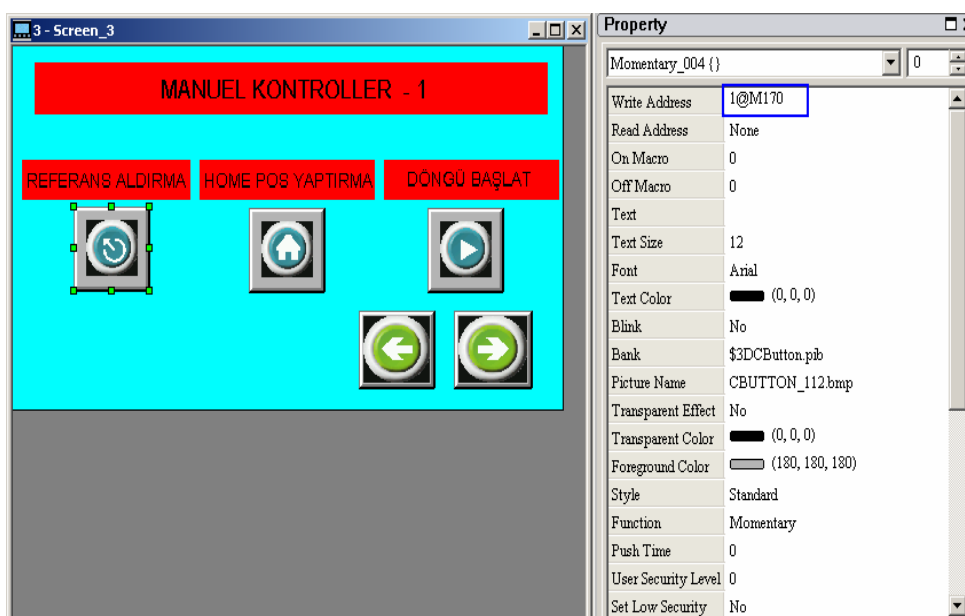

Figure 3.50 The first page of manual control buttons

One of the most important function of operator panels is recipe function. Data with the length as bit, 16 bit and 32 bit, can be sent in HMI. In addition to single data transfer, recipe function allows to send long data groups to PLC together at once. LCD modules with different sizes such as 26”, 32” and 37”, are operated in JI silicone dispenser machine. In this case, motion distance and speed of machine parts change. Instead of sending target positions of mechanism to PLC one by one, sending the data by courtesy of recipe function is more practical.

Therefore position data that was defined as 32 bit and specified for module sizes such as 26”,32” and 37” and target addresses of these data in PLC were entered in “32 bit recipe setup window” that is shown in Figure 3.51. Recipe start address is “D300, it means that position data that belong to any module type are entered plc by starting from “D300” register. For example, since position data require 32 bit registers, the first position data of vertical motion mechanism is sent to plc with “D300+D301” registers and the second position data of vertical motion mechanism is sent with “D302+D303” registers and similarly also all the position data of other mechanisms are sent to plc sequentially.

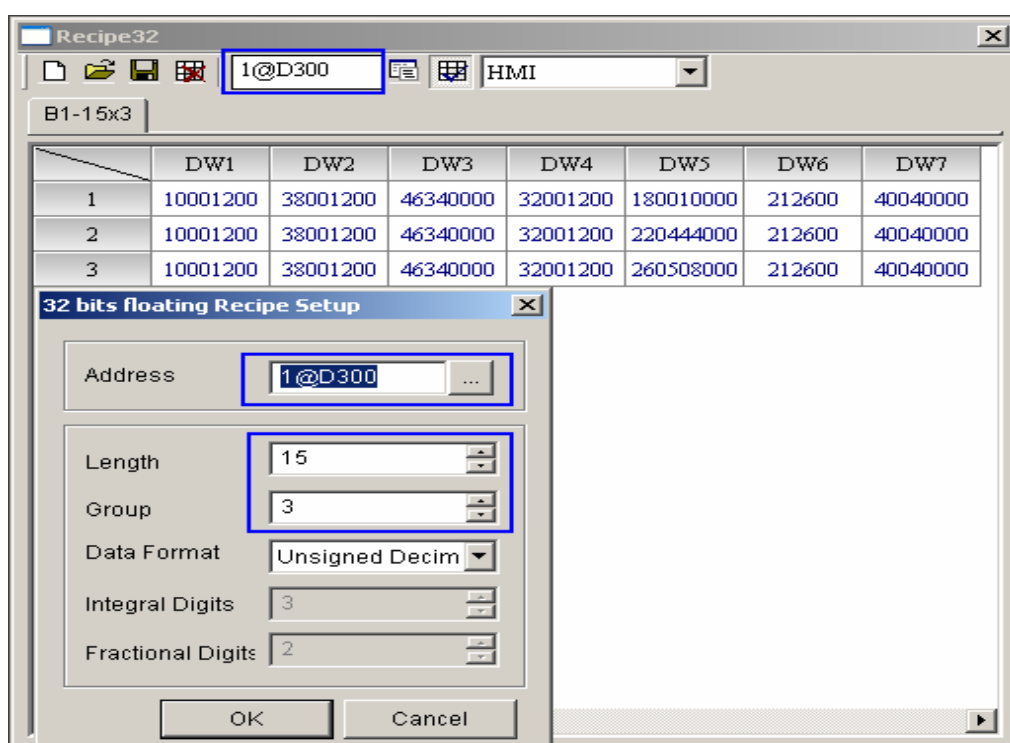

Figure 3.51 Recipe function settings

Delta operator panel requires us to select one type recipe among 32 bit and 16 bit, since we selected 32 bit recipe we sent the mechanism speeds that require 16 bit registers to PLC by visual input elements of HMI such as “numeric input”. The speed data was entered into the registers of plc by using numeric input elements on HMI.

We send the servo driver speed data that we entered into numeric input registers by pressing a visual button makes M100 register of PLC “ON” and M100 register activates the modbus blocks on plc program. Speed data definition is as shown in Figure 3.52.

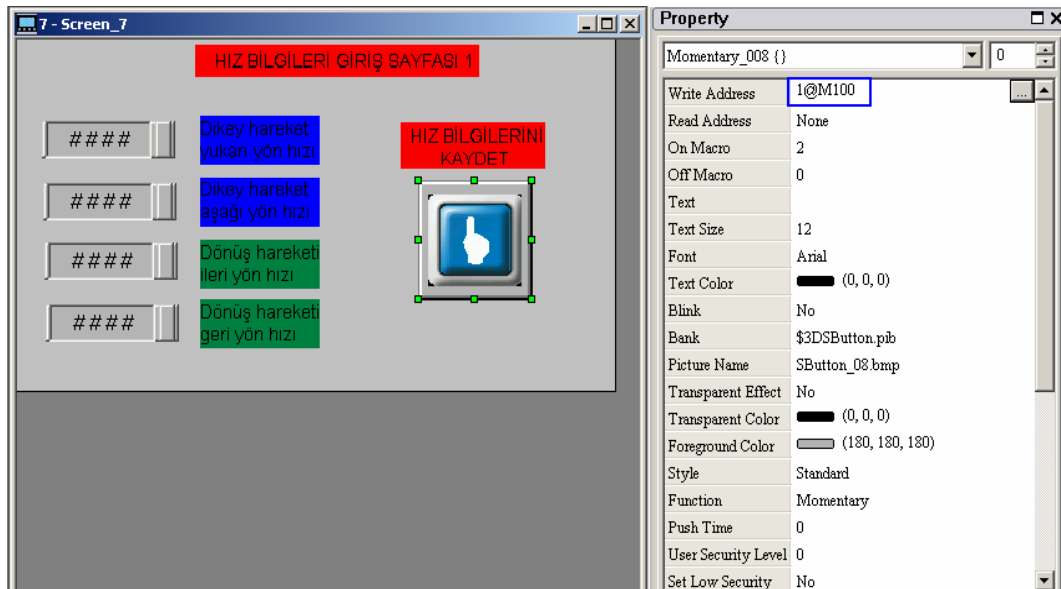

Figure 3.52 Sending the speed data to plc

3.3.3 Servo Driver Programming

In this section, servo driver parameters settings were mentioned as following:

- i) Auto Tuning Function Settings
- ii) Motor Control Mode And Rotation Directions Settings
- iii) Acceleration And Deceleration Ramps Settings
- iv) Input And Output Terminal Settings Of CN1 Connector
- v) Homing (reference operation) Mode Settings
- vi) Speed And Position Definitions Of Internal Positions
- vii) Communication Settings Of Servo Driver

Servo drivers that are used in JI silicone dispenser machine allow three data input methods to programmers.

These methods are setting with “ASD soft” servo driver program, setting with manually on servo driver menu and setting with HMI by courtesy of serial communication. Since setting must be done fast and practical, ASD soft program is not used. The most preferred setting method of servo drivers are manual setting method and setting with communication method. Moreover, there are auxiliary software functions for special applications in ASD soft servo driver program. We executed the auto tuning auxiliary function with manual setting on driver menu but for continuous mode parameters we set the parameters with communication. (ASD-A2 Series User Manual, 2011)

3.3.3.1 Auto Tuning Function Settings

In servo driver programming one of the most used auxiliary function is “Auto tuning”. Position and speed gains and the ratio of load inertia to motor inertia are calculated with Auto tuning function. In “Auto Gain Tuning” window of auto tuning function, after we move servo motor in jog mode (manual mode) servo driver detects the load characteristics and position-speed gains and the ratio of load inertia to motor inertia are written to motor parameters that are shown in Figure 3.53.

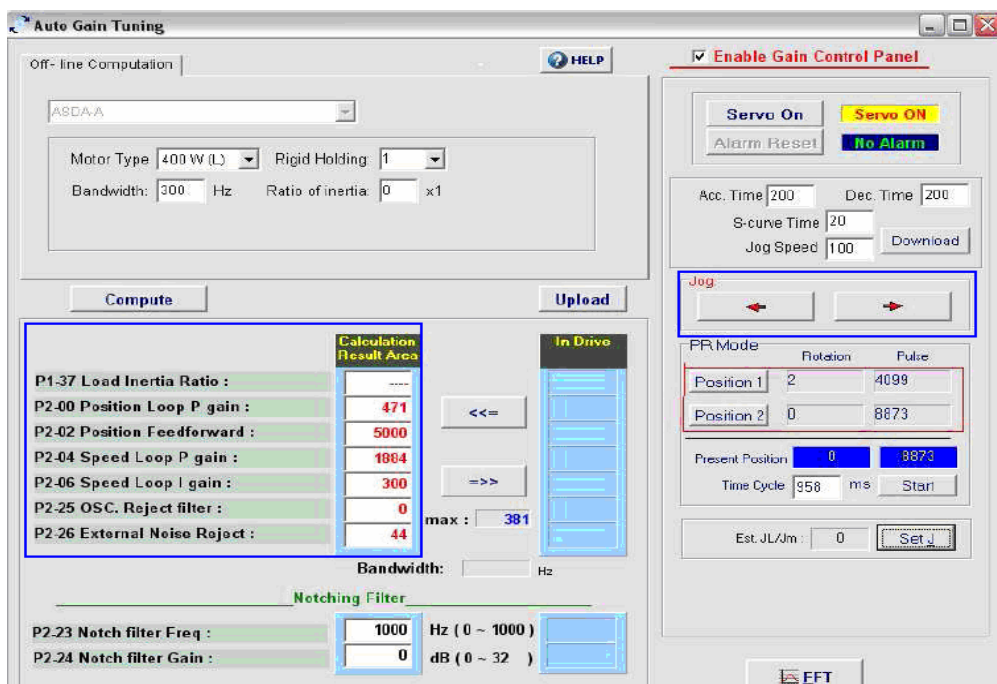

Figure 3.53 Auto tuning function window

After we executed Auto tuning function, we can change auto tuning parameters with manually on servo driver menu and setting with HMI by courtesy of communication. Proportional position loop gain that is one of the most effective parameter for servo motors, mainly affects the transient and steady-state position characteristics of motors. Instead of setting proportional position loop gain manually, we firstly executed auto tuning function then changed KPP. In this case, we set the driver for proper positioning without causing instability. The effect of KPP on positioning is as shown in Figure 3.54.

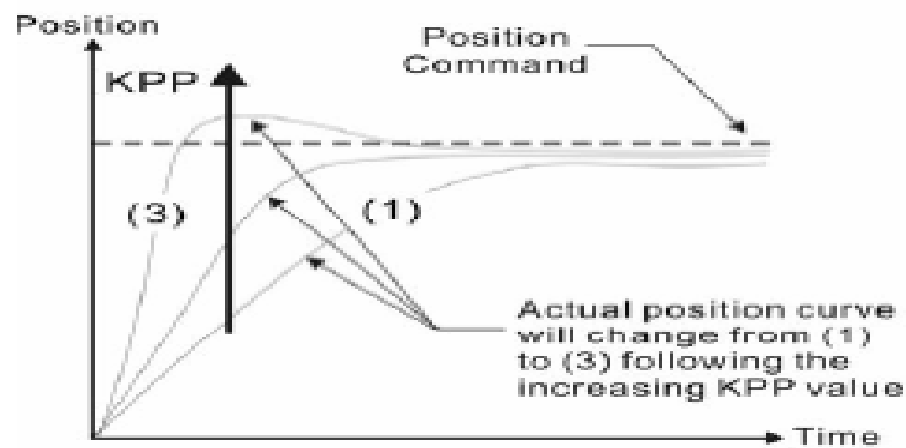

Figure 3.54 The effects of KPP on positioning (ASD-A2 Series User Manual, 2011)

3.3.3.2 Motor Control Mode And Rotation Direction Settings

According to LCD module types, position and speed data for the mechanisms of JI silicone dispenser machine were sent to servo drivers by serial communication from HMI. All the parameters that were explained in servo driver programming section, except speed and position of mechanisms, were entered manually to servo drivers with servo driver menu.

In Delta servo drivers, there are several control modes such as Pt mode (driving with external pulse), Pr (driving with internal positions), speed control and torque control.

In JI silicone dispenser machine, speed and torque of the mechanisms do not continuously change during the motion so there is no need to drive servo motors with speed or torque control modes. Since the position of mechanisms continuously changes, servo motors were driven in position control mode. Mechanisms of JI silicone dispenser machine move to specified positions with specified constant speeds. Therefore Pr mode that allows to define internal positions in servo drivers was chosen for all servo drivers. Control mode was selected with servo driver control mode selection table that is shown in Figure 3.55. According to Figure 3.55, we entered “01” into “A” part of parameter P101.

A: Control mode settings						
	Pt	Pr	S	T	Sz	Tz
Single Mode						
00	▲					
01		▲				
02			▲			
03				▲		
04					▲	
05						▲
Multiple Mode						
0E	▲	▲	▲			
0F	▲	▲		▲		

	Pt	Pr	S	T	Sz	Tz
Dual Mode						
06	▲		▲			
07	▲			▲		
08		▲	▲			
09		▲		▲		
0A			▲	▲		
CANopen Mode						
Reserved						
0D	▲	▲				

Figure 3.55 Servo driver control mode selection table

(ASD-A2 Series User Manual, 2011)

After control mode selection, rotation directions were defined for all servo drivers. When the rotation directions were determined as forward and reverse rotation, servo driver wants from the programmer with a warning message on its display to connect the forward and reverse limit sensors to specified driver terminals. When we connect the limit sensors, servo driver becomes ready to drive servo motor according to specified rotation directions with commands from PLC. Selection of rotation direction of motor must be done as shown in Figure 3.56. According to Figure 3.56, we entered “1” into “B” part of parameter P101.





B: Torque output direction settings		
Direction	0	1
Forward		
Reverse		

Figure 3.56 Selection of rotation direction of servo motor

(ASD-A2 Series User Manual, 2011)

3.3.3.3 Acceleration And Deceleration Ramps Settings

The ramp function of servo drivers that is as shown in Figure 3.57, helps to prevent position errors especially in mechanisms that carry high loads. In addition, ramp function prevents the vibrations in trigger belt-pulley based mechanisms during acceleration and deceleration. The reason of these vibrations is high inertia of mover stage because of high loads.

If we consider the mover stage of mechanisms as a car, ramp function can be thought as the brake control of an experienced driver. Constituents of servo driver ramp functions are as shown in Figure 3.57. According to Figure 3.57, we entered “200(millisecond)” into parameter P134 and P135, and “250 (millisecond)” into parameter P136. These ramps values are proper to make all the mechanism motions stable.

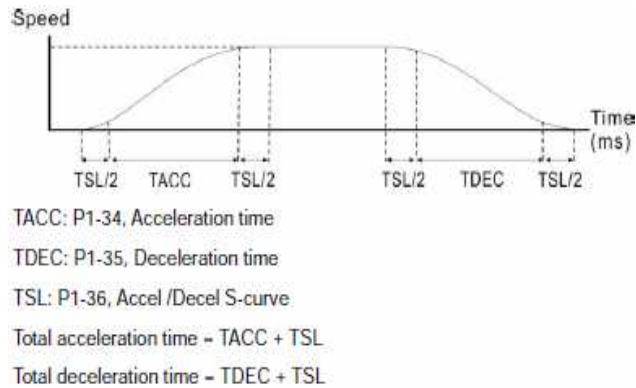

Figure 3.57 Constituents of servo driver ramp functions

(ASD-A2 Series User Manual, 2011)

3.3.3.4 Input And Output Terminal Settings Of CN1 Connector

There are 8 input terminals of CN1 connector. Although there are several input definitions more than 8 in Delta servo driver we can define 8 pieces. Therefore we determined the most essential ones. According to terminal definition function that is shown in Figure 3.58, 1 emergency stop , 3 position definition, 2 limit sensors signals, 1 position pulse and 1 servo driver activation terminals were determined for CN1 connector.

Servo motor can be moved to 8 different positions by courtesy of 3 pieces position definition terminals. In order to define an input terminal, we used the parameters P210 to P217. In order to define the first input terminal as “servo on” that activates the servo driver when we enable it, we entered “101” into parameter P210 and similarly in order to define second in put terminal as “ctrgr” that is a motion start pulse for internal positions, we entered “108” into parameter P211. In order to define the third input terminal as “pos0” that is the first bit of internal position definition function, we entered “111” into parameter P212. In order to define the fourth input terminal as “pos1” that is second bit of internal position definition function, we entered “112” into parameter P213. In order to define the fifth input terminal as “pos2” that is third bit of internal position definition function, we entered “113” into parameter P214. In order to define the sixth input terminal as “emgs” that we use to input safety condition signal to servo driver, we entered “21” into parameter P215.

In order to define the seventh input terminal as “cwl” that we use to input backward limit sensor to servo driver, we entered “22” into parameter P216. In order to define the eighth input terminal as “ccwl” that we use to input forward limit sensor to servo driver, we entered “23” into parameter P217.

P2 - 10	DI1	Digital Input Terminal 1 (DI1)	Address: 0214H, 0215H
		Default: 101	Related Section: Table 8.A
		Applicable Control Mode: ALL	
		Unit: N/A	
		Range: 0 ~ 015Fh	
		Data Size: 16-bit	
		Display Format: Hexadecimal	
		Settings:	
		The parameters from P2-10 to P2-17 are used to determine the functions and statuses of DI1 ~ DI8.	
			
		A: DI (Digital Input) Function Settings: For the setting value of P2-10 ~ P2-17 please refer to Table 8.A.	
		B: DI (Digital Input) Enabled Status Settings: 0: Normally closed (contact b) 1: Normally open (contact a)	

Figure 3.58 CN1 connector input signals (ASD-A2 Series User Manual, 2011)

2 pieces of CN1 terminals were defined as output. Although there are several output definitions more than 2 in Delta servo driver we can define 2 pieces. Therefore we must determine the most essential ones.

According to terminal definition function that is shown in Figure 3.59, 1 piece servo motor position data and 1 piece servo motor reference operation data were defined. These output terminals generate a signal that is used to inform PLC when servo motor reaches the target position and completes the reference operation. In order to define the first output terminal as “TPOS” that we use to inform when servo motor reaches to target position, we entered “105” into parameter P218. In order to define the first output terminal as “HOME” that we use to inform when servo motor completes reference operation, we entered “109” into parameter P219.

P2 - 18	DO1	Digital Output Terminal 1 (DO1)	Address: 0224H, 0225H
		Default: 101	Related Section: Table 8.B
		Applicable Control Mode: ALL	
		Unit: N/A	
		Range: 0 ~ 013Fh	
		Data Size: 16-bit	
		Display Format: Hexadecimal	
		Settings:	
		The parameters from P2-18 to P2-22 are used to determine the functions and statuses of DO1 ~ DO5.	
			
		A: DO Function Settings:	
		For the setting value of P2- 18 ~ P2-22 please refer to Table 8.A.	
		B: DO Enabled Status Settings:	
		0: Normally closed (contact b)	
		1: Normally open (contact a)	
		0: Normally closed (contact b)	
		1: Normally open (contact a)	

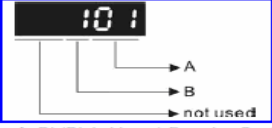
Figure 3.59 CN1 connector output signal (ASD-A2 Series User Manual, 2011)

3.3.3.5 Homing (reference operation) Mode Settings

Homing mode (reference operation) definitions that affect positioning accuracy of the mechanisms directly, were realized with parameters P504, P505 and P506. Delta servo motor with its internal encoder sends the position data to CN2 connector of servo driver but firstly motion start point of servo motor must be defined in order to convert encoder data to significant form. Homing mode function defines the motion start point of the motor. In all of the servo motors in JI silicone dispenser machine, reverse limit sensors were used as home sensor (reference sensor). When servo driver is activated from drivers CN1 terminals by PLC, servo motor starts to rotate in reverse direction in order to find home sensor.

Motor continues to rotate unless mover stage of the mechanism comes in the home sensors detection area. When home sensor detects the mechanism, motor stops and then rotates in forward direction in order to get out from home sensor detection area and then motor stops. Servo driver defines the last position of servo motor as home (reference) position that is also 0 pulse point of internal encoder. In this case, all of the motions of servo motor can be calculated according to reference point.

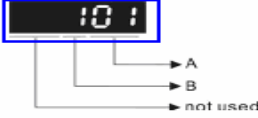
Forward and reverse speeds in reference operation were defined by entering “100 rpm” into parameter P505 that controls the forward motion of reference operation and by entering “40 rpm” into parameter P506 that controls the backward motion of reference operation. We entered “21” into parameter P504 in order to define motor motion that is shown in Figure 3.60.

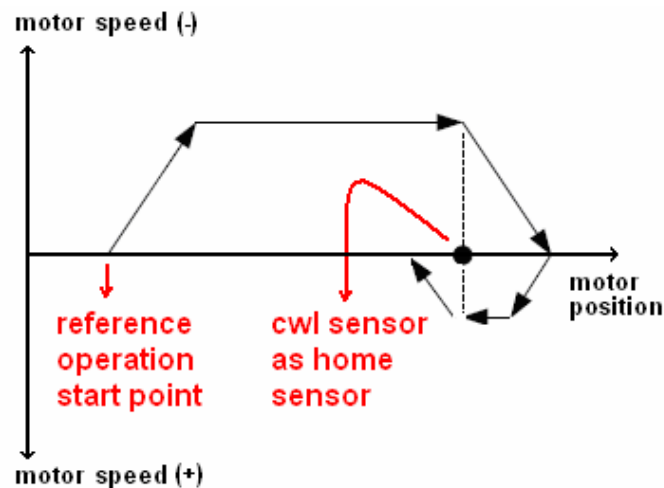

Figure 3.60 Reference operation in homing function

3.3.3.6 Speed And Position Settings Of Internal Positions

Speed and position data were sent by courtesy of recipe function on HMI and positions were defined as pulse with 32 bit range and speeds of mechanisms were defined 16 bit range. Position and speed definitions for internal positioning can be set manually also. We set the speed values of servo motors between the parameters P561 and P564 and for the position definitions we used parameters between P602 and P609. Position definition for internal positioning is as shown in Figure 3.61.

P6 - 03	PDAT1	Data of Path 1	Address: 0606H, 0607H					
Default: 0			Related Section: Section 7.10					
Applicable Control Mode: Pr								
Unit: N/A								
Range: -2147483648 ~ +2147483647								
Data Size: 32-bit								
Display Format: Decimal								
Settings:								
Data of path 1:								
Bit	31 ~ 28	27 ~ 24	23 ~ 20	19 ~ 16	15 ~ 12	11 ~ 8	7 ~ 4	3 ~ 0
Function	DATA (32-bit)							
The parameter P6-02 is used to determine the attributes of definition of Path 1 and parameter P6-03 is used to set the data (target position or jump path number) corresponding to P6-02.								

Figure 3.61 Position definition for internal positioning (ASD-A2 Series User Manual, 2011)

In addition to speed and position definitions, when consider that the internal encoders on servo motors generate 1280000 pulses per a rotation, it can be said that Delta servo motors has a big positioning accuracy.

However, servo motor target positions are defined with an error margin. For example, if the target position is 15000000 pulses, and if error margin was selected 15000 pulses, mover stage of mechanism stops any point in 14985000-15015000 puls range and servo driver detects that servo the motor shaft position as on target position. In order to reach a proper positioning we set “the position completed width” with the parameter P154 as “5000 pulse”.

3.3.3.7 Communication settings

Servo driver accepts the data form PLC with serial communication. Instead of entering the position and speed data of mechanisms on servo driver control menu, we preferred to send these data with serial communication from HMI to PLC and then PLC to servo drivers. In this case, the operators who have no technical knowledge about parameter settings of servo driver can change the parameters for different LCD modules on HMI by courtesy of communication network between control devices. We used the parameters between P300 and P305 in order to set servo driver to modbus communication specifications that we define in PLC.

The parameter P300 that is shown in Figure 3.62, provides us to define communication addresses of servo drivers. We entered address numbers of servo drivers between 2 and 6 into P300 parameters.

P3 - 00	ADR	Communication Address Setting	Address: 0300H, 0301H
Default: 0x7F		Related Section: Section 9.2	
Applicable Control Mode: ALL			
Unit: N/A			
Range: 0x01 ~ 0x7F			
Data Size: 16-bit			
Display Format: Hexadecimal			
Settings:			
This parameter is used to set the communication slave address in hexadecimal format. This address is an absolute address which represents the servo drive on a RS-232/485 or CANbus network.			

Figure 3.62 Communication address settings on p300 parameter (ASD-A2 Series User Manual, 2011)

In order to achieve a serial communication, some parameters as communication protocol, baud rate and data transmission speed must be same for all devices in serial communication network. Baud rate was defined as “9600” for all servo drivers as shown in Figure 3.63.

P3 - 01	BRT	Transmission Speed	Address: 0302H, 0303H
Default: 0x0203		Related Section: Section 9.2	
Applicable Control Mode: ALL			
Unit: bps			
Range: 0x0000 ~ 0x0405			
Data Size: 16-bit			
X: Baud rate setting			
0: Baud rate 4800			
1: Baud rate 9600			
2: Baud rate 19200			
3: Baud rate 38400			
4: Baud rate 57600			
5: Baud rate 115200			

Figure 3.63 Communication speed settings on parameter P301 (ASD-A2 Series User Manual, 2011)

We defined the communication protocol as 7 information bits and 2 parity bits and 1 stop bit similarly to plc communication settings. In order to define protocol specifications we entered “1” into parameter P302 as in Figure 3.64.

P3 - 02	PTL	Communication Protocol	Address: 0304H, 0305H
		Default: 6	Related Section: Section 9.2
		Applicable Control Mode: ALL	
		Unit: N/A	
		Range: 0 ~ 8	
		Data Size: 16-bit	
		This parameter is used to set the communication protocol. The alphanumeric characters represent the following: 7 or 8 is the number of data bits; N, E or O refers to the parity bit, Non, Even or Odd; the 1 or 2 is the numbers of stop bits.	
		0: Modbus ASCII mode, <7,N,2>	
		1: Modbus ASCII mode, <7,E,1>	
		2: Modbus ASCII mode, <7,O,1>	
		3: Modbus ASCII mode, <8,N,2>	
		4: Modbus ASCII mode, <8,E,1>	
		5: Modbus ASCII mode, <8,O,1>	
		6: Modbus RTU mode, <8,N,2>	

Figure 3.64 Protocol definition on parameter P302 (ASD-A2 Series User Manual, 2011)

The parameter P305 that is shown in Figure 3.65 provides us to define com ports as RS-485 that is available for long distance communication. We entered “1” in order to select RS-485 communication interface.

P3 - 05	CMM	Communication Selection	Address: 030AH, 030BH
		Default: 0	Related Section: Section 9.2
		Applicable Control Mode: ALL	
		Unit: N/A	
		Range: 0x00 ~ 0x01	
		Data Size: 16-bit	
		Display Format: Hexadecimal	
		Settings:	
		Communication interface selection	
		0: RS-232	
		1: RS-485	
		Multiple communication modes RS232 and RS-485 cannot be used within one communication ring. Point-to-point connection or multidrop connection can be selected.	

Figure 3.65 Communication port settings for servo driver (ASD-A2 Series User Manual, 2011)

After all of the settings of software of control system, software trials on JI silicone dispenser machine was executed. During software trials firstly machine was worked in manual mode in order to test if PLC outputs connections are correct or not.

If there are not seen any problem on manual controls of PLC, machine is worked in automatic mode. In automatic mode all of the buttons and sensors must be switched on in order to prevent possible software and hardware based problems. All of the mechanical and industrial automation equipments of JI silicone dispenser were tested before it integrate to JI bonding line.

CHAPTER FOUR

OBSERVATIONS ABOUT THE PRODUCTS OF JI SILICONE DISPENSER MACHINE

In order to discuss the improvements of silicone situation on lcd modules after we developed JI silicone dispenser machine, we consider the items such as sensitiveness, manpower, production speed, employee cost, defect ratio, electronic/mechanical based malfunction.

Siliconizing sensitiveness: There must be 1 mm width silicone area on LCD modules. It means that the sensitiveness of the developed machine should be better than 1mm. According to our measurements, the developed machine can put the silicone on target area perfectly, but because test members move LCD modules while silicone is still wet, silicone line can loose its shape a little and there can be seen that there are some parts with different width. It makes the sensitiveness of the developed machine about 0.2 mm sensitiveness on average. This sensitiveness was the same with LCD modules that were siliconized with manual operation. We can see the similarity of the automatic siliconized and manual siliconized LCD modules in Figure 4.1 (a) and Figure 4.1 (b).

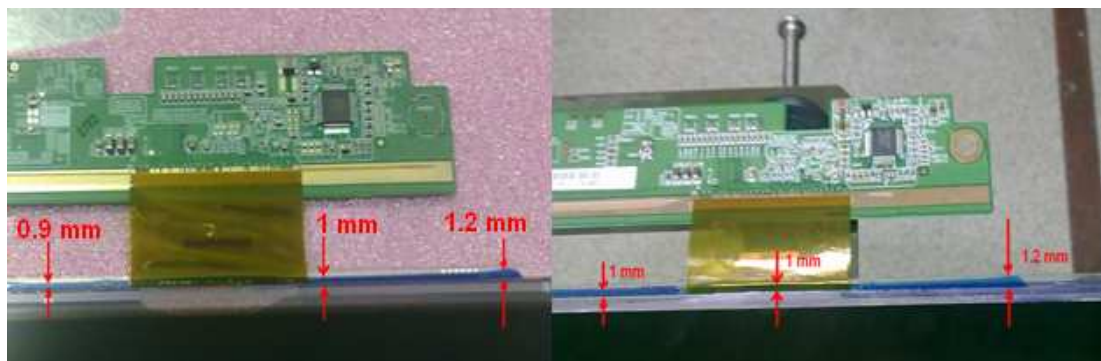

(a)

(b)

Figure 4.1 Comparison of manually and automatic siliconized modules according to silicone width

(a) Manually siliconized lcd module, (b) Automatically siliconized lcd module

If we consider the silicone line situation on different LCD modules that were siliconized with JI silicone dispenser machine, we can see that silicone area is in a continuous line form. There are some bubbles on silicone line but it is not a problem for its endurance against to time and mechanical forces on COF that is the chip on lcd. Silicone situation on different lcd modules is as shown in Figure 4.2.

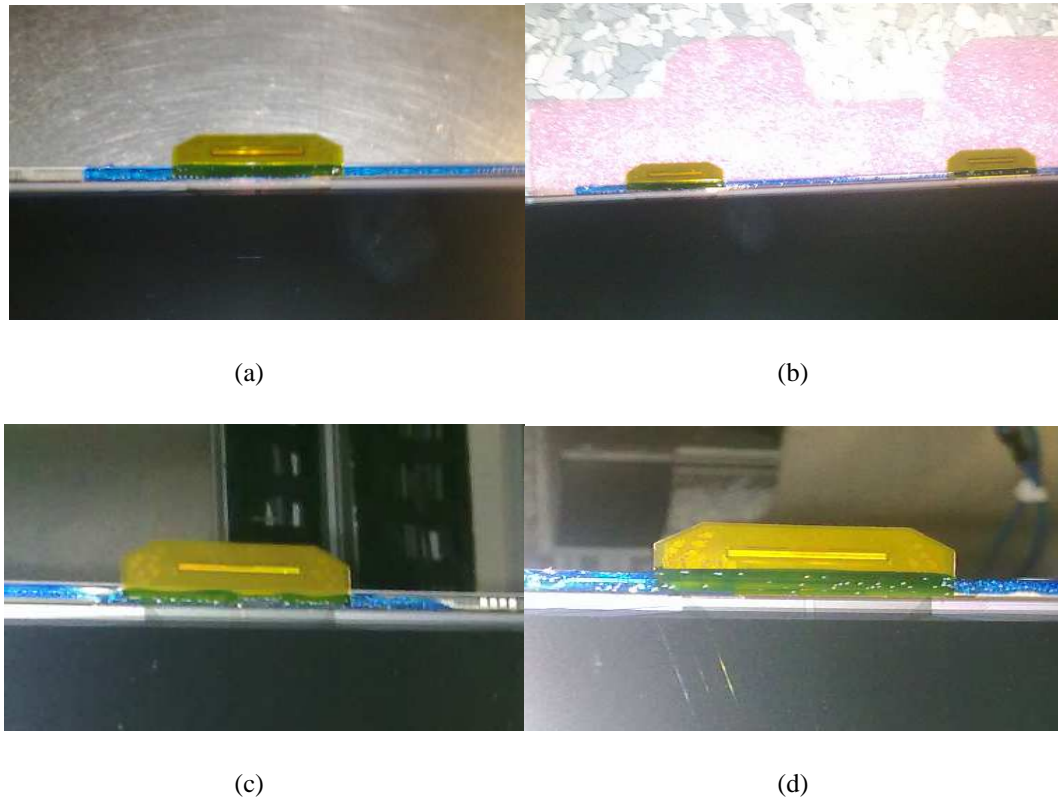

Figure 4.2 Silicone situation on different lcd modules (a) Silicone situation on 40000th lcd module, (b) Silicone situation on 60000th lcd module, (c) Silicone situation on 80000th lcd module (d) Silicone situation on 100000th lcd module

Manpower: Before we developed JI silicone dispenser machine there were four process control members for manual silicone, carriage and test processes. We need two members for only test operation. Since we have saved two members form JI process these members can be charged for other critical operations.

Production speed: When we apply manual siliconizing to LCD modules, since process members executed the carriage and silicone operations manually, siliconized LCD module production speed was almost 80 pieces/hour.

JI silicone machine does not lose any time when an LCD module came to unloader unit of JI bonding line by courtesy of sensor that detects the LCD module existence on unloader unit. This detection and then carriage and siliconizing operations make JI silicone dispenser as fast as JI bonding line with 125 pcs/hour production speed.

Employee cost: In addition to its manufacturing cost advantage, JI silicone dispenser machine has also provided a big employee cost decrease. The employee cost of 4 members that were charged for manual silicone, carriage and test processes, was 4000 \$. Since we have saved two members, the employee cost decreased to 2000 \$.

Defect ratio: There are two basic defect type that occur during the carriage and silicone operations such as “glass broken” and “silicone flow to carriage tray”. If LCD modules do not carried correctly, it can be broken especially on the edges of LCD modules and this defect is represented by the definition of “glass broken”. After siliconizing operation, silicone on LCD module remains still wet and if LCD modules are carried vertically, the silicone on LCD module can flow to carriage tray and this can be failure for siliconizing operation. Silicone flow and glass broken defect ratio were on average 6/10000 and by courtesy of JI silicone dispenser this defect ratio decreased to 3/10000.

Electronic/mechanical based malfunction: JI silicone dispenser showed a big performance since it started to work. There is no electronic or mechanical malfunction or equipment change since it was manufactured. The developed machine produced 120000 pieces siliconized LCD modules without any technical problem.

We can see our comparison items on a table. Table 4.1 shows us the performance of JI silicone dispenser machine. This table proves that the developed JI silicone dispenser machine, in addition to advantages about its manufacturing cost, meets our criterions such as sensitiveness, manpower, production speed, employee cost, defect ratio, electronic/mechanical based malfunction.

Table 4.1 Comparison table of manual silicone and JI silicone dispenser silicone operations

Item	Manuel silicone operation	JI silicone dispenser machine
Sensitiveness	0.2 mm	0.2 mm
Manpower	4	2
production speed	80 pcs/hour	125 pcs/hour
employee cost	4000 \$/month	2000 \$/month
defect ratio (silicone flow +glass broken)	6/10000	3/10000
electronic/mechanical based malfunction		0/120000 pcs

CHAPTER FIVE

RESULTS AND SUGGESTIONS

In this thesis, a JI silicone dispenser machine was designed and controlled according to machine manufacturing and automation principles. A siliconizing operation that requires high performance in positioning accuracy, speed and safety, was realized with an industrial machine instead of a robot manipulator. In addition to advantages about cost, this study has proved that an industrial machine can be designed and manufactured in workshop conditions by using the automation equipments that can be got easily.

The developed JI silicone dispenser machine executes siliconizing of an LCD as the last operation of JI process by working in coordination with JI line. This coordination shows us the integration capability of industrial machines with sophisticated systems. Industrial machines can be used not only for single functions but also in harmony with advanced systems with proper mechanical and electronic connections.

If JI silicone dispenser machine was designed by a professional machine manufacturer, it would cost 278000 dollars and similarly if we use a robot manipulator for siliconizing, it would cost almost 100000 dollars. By courtesy of our original design and control techniques, the cost of our JI silicone dispenser machine was realized about 17000 dollars.

At this point we would like to emphasize the main experiences/observations that we gain during the development process. In the following, we itemize these experiences/observations:

i) This study shows us the necessity of using the servo motors in industrial automation applications. Servo motors provided us setting and programming flexibility. By courtesy of servo driver we could change working conditions of motors and also the mechanisms of machine easily.

ii) Optical limit sensors that we used in start and end points of mechanisms provided us an excellent reference position accuracy. This advantage proves that optical limit sensors should be used instead of proximity sensors in the applications that require high level sensitiveness.

iii) The vertical motion mechanism lifts LCD module, LCD carrier mechanism, rotational motion mechanism and also the vertical iron support block. We choice a ball screw based mechanism in order to support the motor of this mechanism about torque. In addition, we used a motor that has a brake on its shaft. This brake prevents motion of motor shaft unless we apply a 24 V signal on electromechanical brake coils. It shows us the importance of equipment selection according to load and mechanism working conditions. We provided both of positioning accurate and safety with the brake connected to motor shaft.

iv) Since there is 25 kilograms load on main carrier mechanism, mover stage starts motion with a vibration. We solved this problem with reducer with 1:15 reduction ratio. Therefore, the reducer that we used on main carrier mechanism is not only effective in steady state torque but also effective in transient motion of motor.

v) We observed that silicone flow is not good when it first starts. Therefore we adjusted the working level of the vertical motion mechanism and silicone injector air pressure. They show us the importance of equipment selection and the importance of adjustment according to observations.

vi) Although we could use a control panel with buttons, we used an operator panel that has recipe, alarm message and several visual control functions on it. Operator panel usage provided us a professional control and observation on machine. We made the machine usable by any member that has any technical knowledge about the developed machine. This is the most important advantage of operator panels for industrial machines.

vii) Since the mover stage of unloader unit and JI silicone dispenser mechanisms have a common area for motion, we have used position sensors in order to detect the mover stage of unloader unit of JI bonding line.

When the mover stage of unloader unit is on common area, main carrier mechanism waits until the mover stage of unloader unit leaves the common area. We prevented any crash of the mechanisms by these sensors.

viii) When we consider serial communication network of the control equipments of JI silicone dispenser machine, it is obvious that industrial machines can be designed not only for simple machines but also for advanced systems that execute several operation with several control equipments. .

ix) At the beginning of this study, we plan to use image processing technique to improve the accuracy of positioning. But, by the courtesy of stable mechanical equipments and proper drive techniques, the developed machine has high accurate motion capability without using image processing techniques. Since we have not use image acquisition and processing in our design, we have got the opportunity for a big cost reduction.

REFERENCES

- Ahmed, S. F., (2007). A new approach in industrial automation application ‘ embedded system design for injection mold machine’ . *Multitopic Conference, 1-5*
- Anwar, M.R. & Anwar, O. & Shamim, S. F. & Zahid, A. A. , (2004). Human machine interface using of opc(ole for process control). *Student conference on engineering, sciences and technology*, 35-40
- Area sensor .(n.d). Retrieved June 18, 2011, from <http://www.okokchina.com/p/zz-Other-Security-Safety/Laser-Sensor-and-Laser-Area-Sensor-171291.html>
- ASD-A2 Series User Manual.(n.d). Retrieved April 15, 2011, from http://www.delta.com.tw/product/em/motion/motion_servo/download/manual/ASDA-A2_M_EN_20110128.pdf
- Ball screw. (n.d). Retrieved April 22, 2011, from www.nskeurope.com.tr/cps/rde/xchg/eu_tr/hs.xsl/urunler-vidali-miller.html
- Blok Yataklamalar. (n.d). Retrieved June 5, 2011, from <http://www.makina-market.com/tr/dogrusal-hareket-sistemleri/blok-yataklamlar.html>
- Basile, F. & Chiacchio, P. & Gerbasio, D. (2010). A novel approach to plc programming for distributed automation systems control. *Emerging technologies and factory automation (etfa), 2010 ieee conference*
- Can, M. & Gavas, M. & İpek R. (2004). Cnc torna tezgahlarında vidalı milde oluşan aşınma boşluğunun giderilmesi. *Dumlupınar üniversitesi fen bilimleri enstitüsü dergisi*, 4, 237-249
- Cofaso kullanım kitapçığı-sürüm 6. (2008). Retrieved May 10, 2011, from <http://www.scribd.com/doc/32490340/cofaso>
- Davidson, C. & McWhinnie, J. (1997). Stepping off the ladder. *Iee review*, 210-212.

Delta plc, (n.d). Retrieved June 6, 2011, from http://www.fastltd.net/sv_serisi-455_tr_cd.html

Delta 28 sv plc. (n.d). Retrieved June 24, 2011, from http://www.deltaotomasyon.com/deltacd/quick_start/plc/dvpsv.pdf

Delta servo, (n.d). Retrieved June 13, 2011, from http://www.fastltd.net/asd-a2_serisi-494_tr_cd.html

Dop b kullanım klavuzu, (n.d). Retrieved June 16, 2011, from http://www.deltaotomasyon.com/deltacd/quick_start/hmi/dopb.pdf

FS-V11. (n.d). Retrieved June 16, 2011, from <http://www.fs-v11.com>

Gear wheel, (n.d). Retrieved May 29, 2011, from <http://egurcay.wordpress.com/2011/04/12/disli-cark/>

Hametner, R. & Zoitl, A. & Semo, M. (2010) . Automation component architecture for the efficient development of industrial automation systems. *6th iee conference on automation and science*, 156-161.

Hanlon, D. , (2002). Industrial automation applications of ac drives. *Industry applications conference*, 1229-1233

Krishnan, R. (1987). Selection criteria for servo motor drives. *Ieee transactions on industry applications*, 270-275

Lineer araba ve raylar. (n.d). Retrieved May 12, 2011, from <http://www.redomayer.com/lineer.htm>

*Linear mechanism 90*180*, (n.d.). Retrieved June 14, 2011, from <http://www.makina-market.com/tr/dogrusal-hareket-sistemleri/modul-yataklamalar/triger-tahrikli-moduller/43-lineer-triger-modul-90x180.html>

Lineer Motor. (n.d.). Retrieved June 2, 2011, from <http://www.avrasyamuhendislik.com.tr/lineermotor.php>

Linear scale. (n.d.). Retrieved June 12, 2011, from <http://www.gobizkorea.com/blog/ProductView.do?blogid=dongsahn&id=800485>

Low, K. & Keck, M., (2003). Advanced precision linear stage for industrial automation applications. *Ieee transactions on instrumentation and measurement*, 785 – 789

Makaralı Klavuzlama, (n.d.). Retrieved June 1, 2011, from <http://www.kozanlimuhendislik.com/index.php?MenuID=94>

Maslar, M. (1996). Plc standard programming languages. *Pulp and paper industry technical conference*, 26-31

Mesleki eğitim ve öğretim sisteminin geliştirilme projesi (2007). *Sensörler ve transdüserler*. Retrieved May 1, 2011, from <http://cygm.meb.gov.tr/modulerprogramlar/kursprogramlari/elektrik/moduller/sensorlervetranstusorler.pdf>

Mesleki eğitim ve öğretim sisteminin geliştirilme projesi (2007). *Step motor ve sürülmesi*. Retrieved April 17, 2011, from http://megep.meb.gov.tr/mte_program_modul/modul_pdf/523EO0063.pdf

Mesleki eğitim ve öğretim sisteminin geliştirilme projesi (2007). *Servo motor ve sürücülere*. Retrieved April 23, 2011, from http://megep.meb.gov.tr/mte_program_modul/modul_pdf/523EO0076.pdf

- Mesleki eğitim ve öğretim sisteminin geliştirilme projesi (2007). *Operatör panelleri*. Retrieved April 1, 2011, from http://megep.meb.gov.tr/mte_program_modul/modul_pdf/523EO0160.pdf
- Mesleki eğitim ve öğretim sisteminin geliştirilme projesi (2006). *Plc ve montajı*. Retrieved May 11, 2011, from http://www.yozgatempl.com/elk/dokuman%5Cmodul%5C13_5.pdf
- Modicon inc. (1996). *Modicon modbus protocol reference guide*. Retrieved June 1, 2011, from http://www.eecs.umich.edu/~modbus/documents/PI_MBUS_300.pdf
- Motor nedir?*. (n.d). Retrieved April 12, 2011, from <http://www.scribd.com/doc/57082143/motorDokuman>
- Nitzan, D. & Rosen C.A. (1976). Programmable industrial automation. *Ieee transactions on computers*, 1259-1270
- Omron ee-sx671*, (n.d). Retrieved April 12, 2011, from <http://octopart.com/ee-sx671-omron-1317>
- Omron electronics. (2005) *Inductive proximity sensors : design, selection, specification and implementation*. Retrieved May 5, 2011, from [http://www.omron247.com/marcom/pdfcatalog.nsf/PDFLookupByUniqueID/739569C1B6DB368986256B3D0061DF68/\\$File/Selecting_Prox.pdf?OpenElement](http://www.omron247.com/marcom/pdfcatalog.nsf/PDFLookupByUniqueID/739569C1B6DB368986256B3D0061DF68/$File/Selecting_Prox.pdf?OpenElement)
- Oriental motor general catalogue*. (2009). Retrieved June 6, 2011, from http://www.airlinehyd.com/APOLLO/ORIENTAL/AC_MOTORS.PDF
- Peshek, C.J. & Graham J. (1993). Recent developments and future trends in plc programming languages and programming tools for real-time control. *Ieee ias rubber and plastics technical conference*, 102-113

Pla, F.& Sanchiz, J.M.& Sanchez, J.S.,(2001). An integral automation of industrial fruit and vegetable sorting by machine vision. 8th iee international conference on emerging technologies and factory automation, 541-546

Planetary gear, (n.d). Retrieved June 26, 2011, from http://www.obitet.gazi.edu.tr/obitet/sasi_ve_guc_aktarma_organlari/planet_disli_sisi.htm

Profil içi yataklamalar. (n.d). Retrieved May 22, 2011, from <http://www.makina-market.com/tr/dogrusal-hareket-sistemleri/profil-ici-yataklamalar.html>

Rotary encoder, (n.d). Retrieved May 27, 2011, from <http://www.cncmentor.com/rotary-encoders-and-linear-encoders>

Söylemez, E. (2000). *Makine teorisi – 1 mekanizma tekniği*(2). Ankara : Birsen Yayınevi

Step motor. (n.d). Retrieved May 21, 2011, from <http://www.robosan.com.tr/step/mt34fn31.htm>

Servo motor control, (n.d). Retrieved May 28, 2011, from <http://www.tryplc.com/Articles/Servo%20motor%20control%20by%20PLC%20programming.html>

Trigger belt. (n.d). Retrieved May 24, 2011, from <http://www.makina-market.com/tr/dogrusal-hareket-sistemleri/yataklama-ekipmanlari.html>

Türkeş, E. & Orak, S. (2008). Takım tezgahı tasarımında elektrik motoru seçimi. *Dumlupınar üniversitesi fen bilimleri enstitüsü dergisi*, 17, 105-106

Vidali Modül, (n.d). Retrieved May 22, 2011, from <http://www.makina-market.com/tr/dogrusal-hareket-sistemleri/modul-yataklamalar/174-dkm-32-vidali-modul.html>

Venturi, (n.d). Retrieved May 30, 2011, from <http://www.cnczone.nl/viewtopic.php?f=38&t=811>

Vieritz, H. & Yazdi, F. & Schilberg, D. & Jeschke, S. & Göhner, P. (2011). Discussions on accessibilty in industrial automation systems. *9th IEEE International Symposium on Applied Machine Intelligence and Informatics*, 111-116

APPENDICES

Appendix 1

a) Calculation of required torque of vertical motion mechanism

Since LCD module carrier mechanism is a ball screw based mechanism, we calculated required torque by using the ball screw formulas.

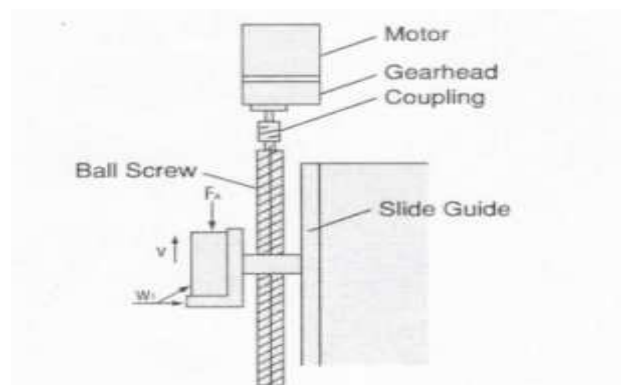

Total mass of table and load $m : 16 \text{ kg}$

Ball screw pitch $P_b : 5 \text{ mm}$

Ball screw efficiency $\eta_b : 0,9$

Ball screw shaft diameter $D_a : 20 \text{ mm}$

Ball screw friction factor $\mu_o : 0,3$

Table friction factor $\mu_t : 0,3 \quad M$

Acceleration due to gravity $g : 10 \text{ m/s}^2$

Safety factor $sf : 2$

Load torque : TL

Load torque with safety factor : TL_{sf}

$$F = \mu_t \cdot m \cdot g = 0,3 \cdot 16 \cdot 10 = 48 \text{ Newton}$$

$$TL = F \cdot Pb / (2 \cdot \tau \cdot \eta_b) + \mu_o \cdot F \cdot Pb / (2 \cdot \tau)$$

$$TL = 48 \cdot 5 / (2 \cdot 3,14 \cdot 0,9) + 0,3 \cdot 48 \cdot 5 / (2 \cdot 3,14)$$

$$TL = 42,46 + 11,46 = 53,92 \text{ N.mm}$$

$$TL_{sf} = sf \cdot TL = 53,92 \cdot 2 = 107,84 \text{ N.mm} = 0,107 \text{ Nm}$$

According to this calculation, ASD A2 type 200 W servo motor that has 0,60 Nm torque is proper to use for vertical motion mechanism. Since there is a little cost difference between 200W and 400W servo motors, we choice 400W servo motor that has 1.27 N.m torque. We choice a motor with mechanical brake in order to support motor against to load and in order to prevent sliding of the mover stage down when motor stops.

b) Calculation of required torque of main carrier mechanism (trigger module with 90mm*180 mm section)

Trigger module gear diameter D : 64 mm,

Trigger module belt roller efficiency μ_b : 0,90 - μ

Reducer ratio i

Reducer efficiency μ_r : 0,90 - μ_g

Table friction factor μ_t : 0,3 -M

Total mass of table and load m : 25 kg

Acceleration due to gravity g : 10 m/s²

Belt displacement per a rotation a = 200 (mm)

Belt speed V = 2000 (mm/sec) = 2000 . 60 (mm/min)

Nominal motor speed..... $V_m = 3000$ rpm

Motor rotation speed r (rpm)

Safety factor $sf : 2$

Load torque : TL

Load torque with safety factor : TL_{sf}

Load torque with reducer : TL_r

Load torque with reducer and safety factor: $TL_{r,sf}$

$$F = \mu t \cdot m \cdot g = 0,3 \cdot 25 \cdot 10 = 75 \text{ Newton}$$

$$TL = F \cdot D / (2 \cdot \mu b) = 75 \cdot 64 / (2 \cdot 0,8) = 3000 \text{ Nmm} = 3 \text{ Nm}$$

$TL_{sf} = sf \cdot TL = 2 \cdot 3 = 6 \text{ Nm}$ with no reducer . I means we must use at least 1500 W servo motor that has 7,16 Nm torque. Instead of using 1500 W motor that has high load capacity and also high cost, we used reducer in order to decrease required torque of the motor.

$$V = a \cdot r \dots 2000 \cdot 60 = 200 \cdot r$$

$$r = 600 \text{ rpm}$$

$i = 3000 / 600 = 5$; This reducer ratio is the minimum ratio, we choice a standard planet reducer with 1:15 reducer ratio then;

$$TL_r = TL / (i \cdot \mu r) = 3 / (15 \cdot 0,9) = 0,222 \text{ Nm.}$$

$$TL_{r,sf} = sf \cdot TL_r = 0,444$$

Nm

According to this calculation, ASD A2 type 200 W motor that has 0,60 Nm torque is proper to use for main carrier mechanism. But in trigger belt mechanisms, if the reducer ratio is not enough, there can occur vibrations acceleration and deceleration of the mover stage therefore we choice 750 W servo motor that has 2.39 Nm torque.

Appendix 2

Wiring Project Of Automation System Of JI Silicone Dispenser Machine

1	2	3	4	5	6	7	8	9	10																					
<table border="1"> <tr> <td>Müşteri</td> <td>:</td> <td>Vestel Dijital A.Ş.</td> </tr> <tr> <td>Tesis tanımı</td> <td>:</td> <td>Bonding</td> </tr> <tr> <td>Çizim numarası</td> <td>:</td> <td>2-2011</td> </tr> <tr> <td>Komisyon</td> <td>:</td> <td></td> </tr> </table>										Müşteri	:	Vestel Dijital A.Ş.	Tesis tanımı	:	Bonding	Çizim numarası	:	2-2011	Komisyon	:										
Müşteri	:	Vestel Dijital A.Ş.																												
Tesis tanımı	:	Bonding																												
Çizim numarası	:	2-2011																												
Komisyon	:																													
<table border="1"> <tr> <td>Üretici şirket</td> <td>:</td> <td></td> </tr> <tr> <td>Dosya ismi</td> <td>:</td> <td></td> </tr> <tr> <td>Proje ismi</td> <td>:</td> <td></td> </tr> <tr> <td>Marka</td> <td>:</td> <td></td> </tr> <tr> <td>Tip</td> <td>:</td> <td></td> </tr> <tr> <td>Kurulum</td> <td>:</td> <td></td> </tr> <tr> <td>Proje yöneticisi</td> <td>:</td> <td>Serkan Çaşka</td> </tr> </table>										Üretici şirket	:		Dosya ismi	:		Proje ismi	:		Marka	:		Tip	:		Kurulum	:		Proje yöneticisi	:	Serkan Çaşka
Üretici şirket	:																													
Dosya ismi	:																													
Proje ismi	:																													
Marka	:																													
Tip	:																													
Kurulum	:																													
Proje yöneticisi	:	Serkan Çaşka																												
<table border="1"> <tr> <td>Oluşturma tarihi</td> <td>:</td> <td>01.11.2010</td> <td>Sorumlu</td> <td>:</td> <td></td> <td>En yüksek sayfa</td> <td>:</td> <td></td> </tr> <tr> <td>Durum</td> <td>:</td> <td></td> <td>Sorumlu</td> <td>:</td> <td></td> <td>Toplam sayfa</td> <td>:</td> <td></td> </tr> </table>										Oluşturma tarihi	:	01.11.2010	Sorumlu	:		En yüksek sayfa	:		Durum	:		Sorumlu	:		Toplam sayfa	:				
Oluşturma tarihi	:	01.11.2010	Sorumlu	:		En yüksek sayfa	:																							
Durum	:		Sorumlu	:		Toplam sayfa	:																							

