



**HYBRID PAVEMENT: ASSESSMENT OF RIGID
AND FLEXIBLE PAVEMENTS TOGETHER**

**2020
MASTER
DEPARTMENT OF CIVIL ENGINEERING**

Ibrahim ALKASAH

Assist. Prof. Dr. Halil İbrahim YUMRUTAŞ

**HYBRID PAVEMENT: ASSESSMENT OF RIGID AND FLEXIBLE
PAVEMENTS TOGETHER**

Ibrahim ALKASAH

**T.C.
Karabük University
Institute of Graduate Programs
Department of Civil Engineering
Prepared as Master Degree**

Assist. Prof. Dr. Halil İbrahim YUMRUTAŞ

**KARABUK
March 2020**

I certify that in my opinion the thesis submitted by Ibrahim ALKASAH titled “HYBRID PAVEMENT: ASSESSMENT OF RIGID AND FLEXIBLE PAVEMENTS TOGETHER” is fully adequate in scope and in quality as a thesis for the degree of Master of Science.

Assist. Prof. Dr. Halil İbrahim YUMRUTAŞ
Thesis Advisor, Department of Civil Engineering

This thesis is accepted by the examining committee with a unanimous vote in the Department of Civil Engineering as a Master of Science thesis. 15.05.2020

Examining Committee Members (Institutions) Signature

Chairman : Assist. Prof. Dr. Fatih SAKA (KBU)

Member : Assist. Prof. Dr. Yavuz DELICE (YU)

Member : Assist. Prof. Dr. Halil İbrahim YUMRUTAŞ (KBU)

The degree of Master of Science by the thesis submitted is approved by the Administrative Board of the Institute of Graduate Programs, Karabük University.

Prof. Dr. Hasan SOLMAZ
Head of the Institute of Graduate Programs



“I declare that all the information within this thesis has been gathered and presented in accordance with academic regulations and ethical principles and I have according to the requirements of these regulations and principles cited all those which do not originate in this work as well.”

Ibrahim ALKASAH

ABSTRACT

M. Sc. Thesis

HYBRID PAVEMENT: ASSESSMENT OF RIGID AND FLEXIBLE PAVEMENTS TOGETHER

Ibrahim ALKASAH

Karabük University

Institute of Graduate Programs

Department of Civil Engineering

Thesis Advisor:

Assist. Prof. Dr. Halil İbrahim YUMRUTAŞ

March 2020, 116 pages

Rigid and flexible pavements have some advantages and disadvantages when compared to each other. Flexible pavements encounter especially rutting deformation due to heavy vehicles and it arises especially on the right (first) lane and on the crossroads that causes waste of national capital due to repetitive repair/rehabilitation works annually but rigid pavements are known to be more resistant to this kind of deformation. With this study, it is aimed to attain the advantages of both pavements applying them together at the same road. The right (first) lane will be designed as rigid and the other will be designed as flexible and called “hybrid pavement” thus combining their advantages on the same road. To prove the efficiency of this application some experiments should be done but as in the literature the first step of these kind of experiments can be computer simulations like Lsdyna, Abaqus, Ansys, etc. to decrease the cost of experiments and to prevent time loss.

In this study the feasibility (the possibility of using the hybrid pavement) is observed with Abaqus software and positive results are obtained. Accordingly, this study will be the first step of future experimental studies or real-time applications.

Key Words : Pavement, hybrid, flexible, rigid, Abaqus.

Science Code : 91125



ÖZET

Yüksek Lisans Tezi

HİBRİT ÜSTYAPI: RİJİT VE ESNEK ÜSTYAPILARIN BİRLİKTE KULLANILMASININ DEĞERLENDİRİLMESİ

Ibrahim ALKASAH

Karabük Üniversitesi

Lisansüstü Eğitim Enstitüsü

İnşaat Mühendisliği Anabilim Dalı

Tez Danışmanı:

Assist. Prof. Dr. Halil İbrahim YUMRUTAŞ

Mart 2020, 116 sayfa

Rijit ve esnek üstyapılar birbiriyle karşılaştırıldığında bazı avantajları ve dezavantajları vardır. Esnek üstyapılar özellikle ağır vasıtalar nedeniyle tekerlek izinde oturma deformasyonu ile karşılaşılır ve her yıl tekrarlanan onarım/rehabilitasyon çalışmaları nedeniyle milli sermayenin israfına neden olan bu durum özellikle sağ (birinci) şeritte ve kavşaklarda ortaya çıkar ancak rijit üstyapıların bu tür deformasyona karşı daha dayanıklı olduğu bilinmektedir. Bu çalışma ile her iki üstyapı türünün de aynı yolda uygulanarak ikisinin de sahip olduğu avantajların elde edilmesi hedeflenmektedir. Sağ (birinci) şerit rijit üstyapı, diğer esnek üstyapı olarak tasarlanacak ve “hibrit üstyapı” olarak adlandırılacak, böylece her ikisinin avantajları aynı yol üzerinde birleştirilecektir. Bu uygulamanın etkinliğini kanıtlamak için bazı deneyler yapılmalıdır ancak literatürde olduğu gibi bu tür deneylerin ilk adımı, deneylerin maliyetini düşürmek ve zaman kaybını önlemek için Lsdyna, Abaqus, Ansys, vb. gibi bilgisayar simülasyonları olabilir. Bu çalışmada, Abaqus yazılımı ile

olabilirliđi (hibrid üstyapının kullanılabilirliđi) gözlemlenmiş ve olumlu sonuçlar elde edilmiştir.

Bu doğrultuda, bu çalışma gelecekte gerçekleştirilmesi planlanan deneyler ve yerinde yapılacak uygulamalar için ilk adımı oluşturacaktır.

Anahtar Kelimeler : Üstyapı, hibrit, esnek, rijit, Abaqus.

Bilim Kodu : 91125



ACKNOWLEDGMENT

First of all, I would like to give thanks to my advisor, Assist. Prof. Dr. Halil İbrahim YUMRUTAŞ, for his great interest and assistance in preparation of this thesis.

I would also like to thank the Head of the Department and all the faculty members of the Civil Engineering Department as well as all the staff of the administrative building and the registration department at Karabük University.

I also thank my father and mother, may God protect them, for their continuous support and pray for me in every prayer of success.

I would like to thank all those who helped me and who had the reason for being in Turkey and at this university and the reason for completing my graduate studies. I would like to thank all the friends and colleagues in Libya and those with Turkey or abroad who have been in contact with me throughout my studies at the university and I appreciate their great support, and their kindness to complete the stage of my studies successfully.

I would like to thank my wife and family for their patience with me throughout my studies.

And dedicate this project to all I mentioned.

CONTENTS

	<u>Page</u>
APPROVAL.....	ii
ABSTRACT.....	iv
ÖZET	vi
ACKNOWLEDGMENT.....	viii
CONTENTS.....	ix
LIST OF FIGURES	xiii
LIST OF TABLES	xvi
SYMBOLS AND ABBREVIATIONS INDEX	xvii
PART 1	1
INTRODUCTION	1
1.1. BACKGROUND.....	4
1.2. SCOPE AND OBJECTIVES OF RESEARCH.....	6
1.3. THESIS STRUCTURE	8
PART 2	10
LITERATURE REVIEW	10
2.1. AASHO ROAD TEST PROJECT.....	15
2.2. OBJECTIVES OF AASHO ROAD TEST.....	17
2.3. BACKGROUND HYBRID PAVEMENT.....	17
PART 3	21
THEORETICAL BACKGROUND.....	21
3.1. PAVEMENT TYPES	21
3.2. FLEXIBLE PAVEMENTS	22
3.3. LOW STANDARD FLEXIBLE PAVEMENTS	23
3.4. HIGH STANDARD FLEXIBLE PAVEMENT.....	24
3.5. FLEXIBLE PAVEMENTS DEFECTS AND THEIR REASONS	25

	<u>Page</u>
3.5.1. Advantages of Flexible Pavement	25
3.5.2. Disadvantages of Flexible Pavement.....	26
3.5.3. Failures in Flexible Pavements	26
3.5.3.1. Weather Conditions	26
3.5.3.2. Use of Chemical and Salts in Colder Climates	27
3.5.3.3. Ultraviolet Rays	27
3.5.3.4. Water (Natural Rain and Irrigation).....	28
3.5.3.5. Vehicle Loads and Petroleum	29
3.5.3.6. Aging of Flexible Pavements.....	29
3.5.3.7. Alligator Cracking of Flexible Pavements.....	29
3.5.3.8. Depression Distress in Flexible Pavements	30
3.5.3.9. Shoving	31
3.5.3.10. Longitudinal and Transverse Cracking Distress	31
3.6. RIGID PAVEMENTS	32
3.6.1. Types of Rigid Pavements	33
3.6.2. Jointed Plain Concrete Pavement	34
3.6.3. Jointed Reinforced Concrete Pavement.....	35
3.6.4. Continuous Reinforced Concrete Pavement.....	36
3.6.5. Pre-stressed Concrete Pavement.....	37
3.6.6. Roller Compacted Concrete.....	38
3.6.7. Rigid Pavement Defects and their Reasons	39
3.6.7.1. Advantage of Rigid Pavement	40
3.6.7.2. Disadvantages of Rigid Pavement	40
3.6.8. Joint Spalling in Rigid Pavements.....	41
3.6.9. Faulting in Rigid Pavements.....	42
3.6.10. Polished Aggregate in Rigid Pavements	42
3.6.11. Shrinkage Cracking in Rigid Pavements	43
3.6.12. Pumping Effects	44
3.6.13. Corner Breaks in Rigid Pavements.....	44
3.6.14. Punch-out in Rigid Pavements	45
3.6.15. Linear Cracking in Rigid Pavements.....	45
3.6.16. Durability Cracking in Rigid Pavements.....	46

	<u>Page</u>
3.7. COMPARISON OF RIGID AND FLEXIBLE PAVEMENTS	47
PART 4	52
PAVEMENT DESIGN CRITERIA'S	52
4.1. TECHNICAL CRITERIA FOR SUPERSTRUCTURE TYPE SELECTION	52
4.1.1. Traffic Effects	52
4.1.2. Climate and Environmental Impacts	53
4.2. ECONOMIC CRITERIA IN SUPERSTRUCTURE TYPE SELECTION...	55
4.2.1. First Construction Cost	56
4.2.2. Maintenance-Repair-Operating Cost during Project Life	56
PART 5	61
HYBRID PAVEMENTS	61
5.1. PROBLEM STATEMENT.....	61
5.2. HYBRID PAVEMENT	61
5.3. THE IMPORTANCE OF HYBRID PAVEMENT	65
5.4. WHY CHOOSE CEMENT INSTEAD OF ASPHALT	66
5.5. USING THE RIGID PAVEMENT IN TURKEY	67
5.6. COLLECTIVE INFLEXIBLE DISTRESSES OF PAVEMENT	70
5.7. THE FOLLOWING EXPERIMENTS	72
5.8. THE FOLLOWING SOFTWARE CAN BE USED TO TEST THE IDEA OF WORK	74
5.9. THE JOINTS AND THEIR LAYOUT	75
5.10. USING ABAQUS SOFTWARE ON HYBRID PAVEMENT	79
5.11. ANALYSIS MODEL	81
5.12. ELEMENT TYPES AND MESH SIZE	82
5.13. MATERIALS	82
5.14. JOINT SEALANTS AND MASTICS.....	83
5.14.1. Features and Benefits.....	83
5.15. BOUNDARY CONDITIONS	85
5.16. RESULTS	85
5.17. SUMMARY FOR THE RESULT	100

	<u>Page</u>
5.18. COST ANALYSIS	101
PART 6	105
CONCLUSION.....	105
REFERENCES.....	109
RESUME	116



LIST OF FIGURES

	<u>Page</u>
Figure 1.1. Roads by surface type in Turkey as of 2019.....	4
Figure 2.1. Pavement Structure.....	12
Figure 2.2. Practical experience to replace flexible paving with other rigid pavement in a City of Hamilton.....	20
Figure 3.1. Flexible pavement and rigid pavement.....	21
Figure 3.2. The differentiate between flexible pavements and rigid pavements	22
Figure 3.3. Flexible Pavement Cross Section	23
Figure 3.4. Load distributions occurring in superstructures	24
Figure 3.5. Change in weathers.....	27
Figure 3.6. Shows using the salts in snow climates	27
Figure 3.7. Show the change of the climates including Ultraviolet rays	28
Figure 3.8. Show water can enter to the base and the subgrade.....	28
Figure 3.9. Alligator cracking	30
Figure 3.10. Depression distress	30
Figure 3.11. Shoving	31
Figure 3.12. Longitudinal cracks in asphalt flexible pavement	31
Figure 3.13. Transverse cracking in asphalt flexible pavement.....	32
Figure 3.14. Cross section of rigid pavement	33
Figure 3.15. Cross section of jointed plain concrete pavement	35
Figure 3.16. Cross section of joint reinforced plan.....	36
Figure 3.17. Cross section of continuous reinforced concrete pavement	37
Figure 3.18. Cross Section of Plain Concrete Pavement	38
Figure 3.19. A cross section of RCC.....	39
Figure 3.20. Joint spalling in rigid pavement slabs.....	41
Figure 3.21. Faulting with difference in elevations found between the joints.....	42
Figure 3.22. Polished aggregates	43
Figure 3.23. Shrinkage cracking in pavements	43

	<u>Page</u>
Figure 3.24. Pumping effect.....	44
Figure 3.25. Corner breaks in rigid pavements	44
Figure 3.26. Punch-out failures in rigid pavements	45
Figure 3.27. Linear cracking	46
Figure 3.28. Durability cracking or ‘d’ cracks failure in rigid pavements.....	46
Figure 4.1. Deformation due to environmental factors.....	53
Figure 4.2. Data used in the design	59
Figure 5.1. Asphalt rutting and deformations in Karabük – Turkey.....	62
Figure 5.2. The rutting and deformation of asphalt in Karabük - Turkey.....	63
Figure 5.3. During turns, partial transfer of the load to the outer wheel.....	63
Figure 5.4. In straight alignment: even distribution of the load on both wheels.....	64
Figure 5.5. Shows the problems that occur in the traffic roundabout.....	64
Figure 5.6. The idea of flexible pavement and rigid paving in the single road line	65
Figure 5.7. Shows the difference between the use of bitumen or concrete.....	66
Figure 5.8. Design of hybrid road	68
Figure 5.9. Shows the use of rigid paving in the traffic roundabout in French	68
Figure 5.10. Rigid paving	69
Figure 5.11. Shows us of rigid paving deformations	72
Figure 5.12. French rutting test.....	74
Figure 5.13. Hamburg wheel tracking device	74
Figure 5.14. Shows the distances between concrete slabs as well as joints.....	76
Figure 5.15. Shows the basket support dowel joints.....	77
Figure 5.16. Shows basket support dowel.....	77
Figure 5.17. Construction joint	78
Figure 5.18. Construction joint	78
Figure 5.19. The spacing between the concrete.	79
Figure 5.20. Pavement design due to rutting criterion	80
Figure 5.21. General shape of the road	80
Figure 5.22. Case-1 the effect of load on the both of the pavement.	81
Figure 5.23. Case-2 the effect of load on the joint.....	81
Figure 5.24. Boundary conditions.....	85

	<u>Page</u>
Figure 5.25. Model of displacement with repeated loads.	86
Figure 5.26. Ruth Depth for Each Passes.....	86
Figure 5.27. Predictive rutting due to repeated load	87
Figure 5.28. Plastic strain in the direction of “y”	88
Figure 5.29. Plastic equivalent strain	88
Figure 5.30. Vertical plastic strain vs pavement depth-flexible pavement side.....	89
Figure 5.31. Predicted surface rut profile in the horizontal direction	89
Figure 5.32. Model of displacement with repeated loads in the joint.....	90
Figure 5.33. Ruth depth for each passes in the joint	90
Figure 5.34. The vertical plastic strain distribution on the joint.	91
Figure 5.35. Plastic strain in the direction of “y”.....	91
Figure 5.36. Vertical plastic strain vs pavement depth-flexible pavement side.....	92
Figure 5.37. The predicted surface rut profile beneath the load	92
Figure 5.38. Boundary conditions.....	93
Figure 5.39. Vertical displacement of the pavement after 1000 passes.....	94
Figure 5.40. Ruth Depth for Each Passes.....	94
Figure 5.41. Plastic strain in the direction of “y”.....	95
Figure 5.42. Plastic equivalent strain	95
Figure 5.43. Vertical plastic strain vs pavement depth-flexible pavement side.....	96
Figure 5.44. Vertical displacement along the pavement surface.	96
Figure 5.45. Stress distribution on the pavement.....	97
Figure 5.46. Wheel on the Joint.	97
Figure 5.47. Ruth Depth for Each Passes.....	97
Figure 5.48. Plastic strain in the direction of “y”.....	98
Figure 5.49. Plastic equivalent strain.	99
Figure 5.50. Vertical plastic strain vs pavement depth.	99
Figure 5.51. Vertical displacement along the pavement surface.	99
Figure 5.52. The LCCA methodology are as follows.....	103

LIST OF TABLES

	<u>Page</u>
Table 1.1. Shows the total roads in Turkey until 2019	3
Table 4.1. Vehicle equivalence factors	58
Table 4.2. Recommended load transfer coefficients for various coating types	59
Table 4.3. Data used in design	60
Table 5.1. Rigid superstructure applications in Turkey	67
Table 5.2. RCC road applications made in various regions of Turkey	70
Table 5.3. Key of the layout.....	82
Table 5.4. Material properties of flexible pavement.....	82
Table 5.5. Material properties of soil mechanical.....	83
Table 5.6. Material properties of concrete mechanical.....	83
Table 5.7. Material properties of Steel mechanical.....	83
Table 5.8. Material properties of joint between rigid and flexible pavement.....	84

SYMBOLS AND ABBREVIATIONS INDEX

SYMBOLS

W18	: Predicted Number of 18 kip Traffic Load Application (ESAL)
ZR	: Standard Normal Deviate
So	: Combined Standard Error of Traffic Prediction
SN	: Structural Number
ΔPSI	: Serviceability Changes During The Design Period
MR	: Resilient Modulus (psi)
W18	: Equivalent Axle Load Repeat Number (EDYTS)
D	: Coating Thickness (inc)
Sc	: Concrete Flexural Strength (psi)
Ec	: Elasticity Module of Concrete (psi)
K	: Ground Reaction Module (lb / inc ³) R: Reliability (%)
ZR	: Normal Standard Deviation
SO	: Total Standard Deviation
O	: PSI Loss of Service Ability
PI	: First Service Ability
PT	: Last Service Ability
CD	: Drainage Coefficient
J	: Load Transfer Coefficient

ABBREVIATIONS

FEM	: Finite Element Model
FE	: Finite Element
TÜİK	: Turkish Statistical Institute (TSI)
KGM	: General Directorate of Highways (GDH)

TÜPRAŞ	: Turkey Petroleum Refineries Corporation (TPRC)
AASHTO	: American Association of State Highway and Transportation Officials
WASHO	: Western Association of State Highway Officials
TÇMB	: Cement Manufacturers Association of Turkey (CMAT)
YOGT	: Annual Average Daily Traffic (AADT)
ASMÜD	: Asphalt Contractors Association (ACA)
TurkStat	: Turkish Statistical Institute
LCCA	: Life-Cycle Cost Analysis
LCPC	: Laboratoire Central des Ponts et Chaussées
NPW	: Net Present Worth method
BOT	: Build–operate–transfer
B/C ratio	: Benefit Cost Ratio
IRR	: Internal Rate of Return
EUAC	: Equivalent Uniform Annual Cost method
BOT	: Build–operate–transfer
AC	: Asphalt Concrete
PCC	: Portland cement concrete
JPCP	: Jointed plain concrete pavement
JRCP	: Jointed reinforced concrete pavement
CRCP	: Continuous reinforced concrete pavement
PCP	: Pre-stressed concrete pavement
RCC	: Roller compacted concrete
HMA	: Hot Mix Asphalt
PCC	: Portland Cement Concrete

PART 1

INTRODUCTION

During the last century, roads and highways are developed dramatically in order to be able to fulfil the needs of humanity. Roads and highways are developed continuously to move people and vehicles from one place to another comfortably. The surface used in movement of human and vehicles is known as pavement. These pavements have great importance and highly depend on vehicles factors, speed, comfort and quality. The previous factors are taken into account by people who use these pavements to move from one place to another. Currently, there are great needs for infrastructure of roads and highways and they are considered important for our life [1].

Pavements play as significant role to up shift the country economy and that cannot be neglected. The developed infrastructure of highways and roads with effective transportation system is considered one of the basic factors of development in any country. The difference at infrastructure in developed and developing countries is high and clear. Also, some underdeveloped countries which have not basic infrastructure of roads. Nevertheless, demand of good infrastructure is increasing in all countries significantly because of its ability to enhance not only the economy but also, the industrial development of the country. There are two common types of pavements (flexible pavements and rigid pavements) .Flexible pavements designed from bitumen , and rigid pavements designed from concrete . The trend of existing road in most of the developing countries is bituminous pavement. This is because of the fact that these countries looked to construct flexible pavement without taking efforts to construct any pavement and make comparison analysis between the types of pavements that considered significant to take the right selection to develop pavements [1].

When it comes to safety, comfort, serviceability and durability, there is great demand on rigid pavements. Rigid pavement has witnessed great popularity in all parts of the World because of its good performance and ability to stand with submerged circumstances and environment.

Moreover, rigid pavement needs less amount of aggregates and because of great amount of cement available locally and increasing the prices of oil in international market. So, it has great practicably. If the new roads constructed with cement concrete, the future demands on bitumen roads can be avoided. During the last few years, pavements witnessed great amount of development and researchers showed many new standards and requirements of surface features. One of the most used elements in pavement construction is asphalt. The surface properties are the most important surface contact with vehicle tires and able to deliver speed and comfort during the travel without effecting the safety of vehicles and passengers [2].

The asphalt is defined as solid or viscous liquid include basically of hydrocarbons and their derivatives that is soluble in trichloroethylene. Generally, it is non-volatile and softens when it is heated. Its color is black or brown and has insulating and glue features. In addition, it is available as natural element of natural bitumen or natural standby that exists with the mineral materials [1].

Asphalt is used as adhesive or sealant material in wide applications that generally subject to civil engineering (protection reservoirs and dams, road construction and construction of varnishes building). Asphalt is obtained both from the natural resources and from the derived fractional distillation of crude oil (oil asphalt). Oil bitumen is considered the most popular asphalt as it is considered a cheap because of collecting asphalt is complex and expensive. The most important use of asphalt is in road surface where it is used as a binder between the classified collections of its production [3].

In Turkey there are about 14,000 km of highways from the Ottoman Empire were deteriorated and there is significance of care that is 18,365 kilometers. After declaring the republic of turkey inside the national Turkish borders, 13,900 km of

which are stabilized roads and 4,450 km of soil. After the establishment of KGM road network, the network of road in Turkey has been enhanced. In the beginning of 2019, the total length of roads under the responsibility of General Directorate of Highways (GDH) accessed to 67,333 km. It includes three classes of road network including highway road state road and provincial road. Turkish Statistical Institute (TurkStat) stated that the number of motor vehicles in turkey is reached to 22,940,636.00 in the beginning of 2019. Also, the number of vehicles in the roads are increasing day by day and led at the end to faster deterioration in the roads. [4,5].

The length of highways under the responsibility of KGM is 67.333 km as of 2019 and it consists of 3 class road networks, namely the provincial road, highway and state road. GDH is a legal entity organization affiliated to the Ministry of Transport and Infrastructure today, and with the Law No. 6001, GDH, the state and plan, project, construction, maintenance, repair and operation of the provincial roads have been given to GDH. [4,5].

Table 1.1. Shows the total roads in Turkey until 2019[5].

	Asphalts Concrete	Surface Treatment	Parquet	Stabilized	Soil	Other Ways	Total
Highway	2,159	-	-	-	-	-	2,159
State Roads	17,520	13,115	58	27	-	301	31,021
Provincial Roads	4,403	26,218	232	537	443	2,320	34,153
Total	24,082	39,333	290	564	443	2,621	67,333

Road construction with quality and comfort equipment that response to increase the traffic require high amount of costs for construction and maintenance. In order to reduce this cost, it is possible to use the rigid superstructures (concrete roads) which created by local cement and signify the national capital by 100% for various years with less cost and problems. Figure 1.1. Shows that in 2019, there was only 0.02% km of concrete road trails [5, 6].

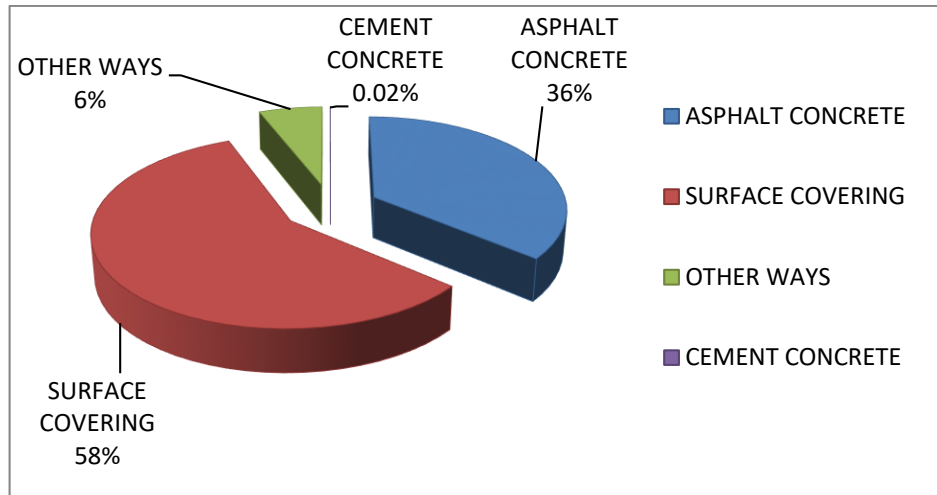

Figure 1.1. Roads by surface type in Turkey as of 2019 [4].

Also we can see the increasing rate of vehicles and increasing rate of the road network in Turkey every ten years from 1988-2018, vehicle amount was increasing and road network was increase in Turkey has a consistent rate so newer roads needs to be constructed every year and so a new method (hybrid pavement) can be applied and experienced. Figure 1.2 show the road lengths with different type of pavement and Figure 1.3 show the number of vehicles in Turkey from 1988-2018

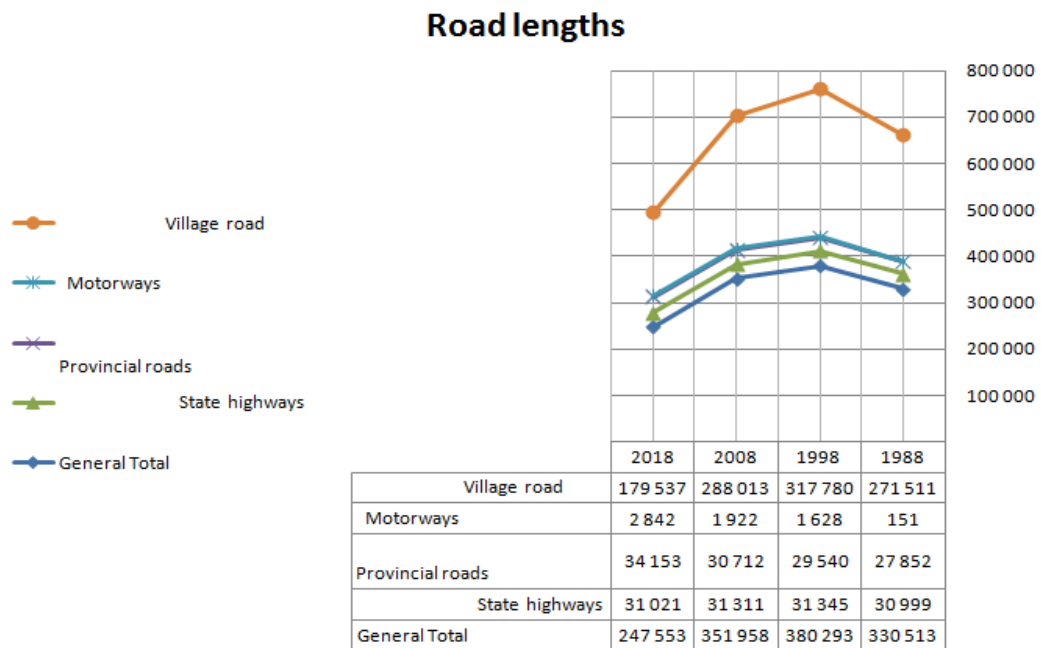

Figure 1.2. road lengths of pavement in Turkey from 1988-2018[4].

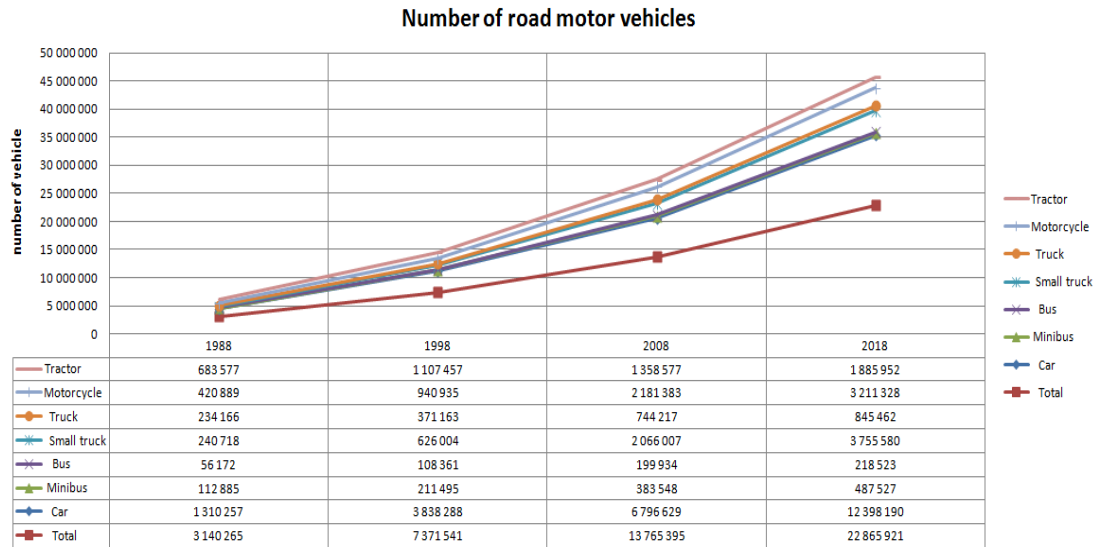

Figure 1.3. number of vehicles in turkey from 1988-2018[4].

1.1. BACKGROUND

Generally, the rigid pavements are not used in roads where engineers think that this type of pavements includes high initial cost without any suitable economic analysis. There is misunderstanding with road designers and planners associate with rigid pavement use and implementation and also, misunderstanding with method of construction and associated costs. Although that one of the main shortcoming in rigid pavement is high initial cost of construction but when we look to the operating and functional cost and before everything , cement concrete pavements became common in all parts of the world according to the lifecycle of rigid pavement [79].

The development of modern techniques in the production of durable concrete, increase the prices of oil and the participation of private sector in the development of road infrastructure made the selection of pavement in many high level road projects constructed especially under the BOT (Build–operate–transfer) concept [79] .

Literature reveals that the long age feature is desired widely in private sector projects where the rent period reaches to thirty years. The good investor thinks that his project continuous for the entire period of distinction without the need to main rehabilitation

or repair. However, a bituminous pavement needs continuous renewal. This may happen each seven years in average as mentioned in the actual care [79].

One of the major procedures associate with traffic is decreasing the maintenance works especially in overcrowded roads. In underdeveloped and developing countries, the flexible pavement is deteriorated continuously. because of poor quality of construction materials. So, governments must spend more moneys in order to maintain roads in all parts of the country. It is necessary to conduct a comparison between rigid and flexible pavement and conduct field study to determine the associated problems in the construction of flexible pavement and discover the type of suitable pavement and local traffic circumstances [79].

1.2. SCOPE AND OBJECTIVES OF RESEARCH

Nevertheless, all new pavements since the delivering time begins definitely under the distressing impact of foreign elements including cars and weather conditions. Thus, there are efforts continued for many years in order to check and measure the features of the surface by the creation of tools and suitable measurement systems. Traditional measurement tools are used in most of road construction works while there were attempts for similar development in last years. During the last fest years, the development of technology enabled attempts to create modern ways and register the characteristics of surface or compact the developed technology with present technology [5]. One of the pavement deterioration consequences is the development of residual pavements according to the design concept of pavement because of the failure of soil deterioration. However, distortion of asphalt layers may cause deterioration of pavement. Generally, permanent deformation of roads is caused by many factors such as bad quality of materials of the layers and the impact of climate conditions [6]. It causes deformation to the features of pavement in addition to level of comfort for the road users. Therefore, in order to reduce the probability of occurrence particularly in first pavement services periods. It is significant to study the behavior of factors effecting its structural status. As a part of this study, it comprises the need to offer the remaining deformation.

The provision of permanent deformation is considered important in each of construction and design phase and during the operation in pavement phase. The impact of factors on the development is revealed and it may provide information about the road behavior against load of traffic. This offers good administration for road network. Continuous maintenance in suitable time for surface of roads is considered a basic tool for management systems. Continuous monitoring and determine two suitable times to respond lead to increase the life and restore their functionality to the appropriate service level [7].

The residual deformation can be predicted by the statistical, engineering and experimental standards. The first need is to monitor the data related to road surface and it is limited while the experimental models rely on the experimental functions and relations growing from the measured or perceived information. So, in order to investigate the pavement behavior accurately and provide the deformation of pavement, it is necessary to take into account the mechanical characteristics of materials and the use of appropriate mechanical standards [8].

In the following sections, we provided the characteristics of asphalt surface and the traditional tools used to measure each one of them. In addition, the goal is to focus on the proportional analysis between rigid and flexible pavements by taking into account the major cost, availability of materials, performance of pavements under climatic and submerged circumstances and possibility of long service.

Rigid and flexible pavements have some advantages and disadvantages when compared to each other. Flexible pavements encounter especially rutting deformation due to heavy vehicles and it arises especially on the right (first) lane and on the crossroads that causes waste of national capital due to repetitive repair/rehabilitation works annually but rigid pavements are more resistant to this kind of deformation. With this study, It is aimed to attain the advantages of both pavements applying them together at the same road. The right (first) lane will be designed as rigid and the other will be designed as flexible and called “hybrid pavement” thus combining their advantages on the same road. But to prove the efficiency of this application some experiments should be done but as in the literature the first step of these kind of

experiments can be computer simulations like Lsdyna, Abaqus etc. to decrease the cost of experiments and to prevent time loss. In this study the feasibility (the possibility of using the hybrid pavement) is observed with Abaqus software and positive results are obtained. The goals of the proposed study can be summarized as follows:

- In order to check the weakness factors, associate with construction and monitoring of quality for rigid and flexible pavement.
- In order to discover the performance of rigid and flexible pavement in terms of submerged circumstances.
- In order to discover the possibility of using the hybrid pavement by the use of Abaqus software program.

It is probable that the results of the research may help in enhancing the associated problems in the construction of pavement. In addition, it is probable that the research results help to discover the use of hybrid pavements and therefore encourage the use of locally available cement in Turkey instead of using the imported bitumen in construction of pavement.

1.3. THESIS STRUCTURE

This study comprises six chapters. At this step, we will clarify a summary of each chapter.

Chapter 1 is the introduction to the topic and also consists the research questions and objectives of the study.

Chapter 2 includes the literature review on the pavement design and development, in addition to the main reasons for the asphalt fatigue, and the causes of deterioration.

Chapter 3 clarifies in details the potential comparison of rigid and flexible pavements. Specifically, a review is performed on the theoretical underpinnings of dynamic stiffness measures and describes methods for determining by laboratory

testing and prediction algorithms in order to be able to make suggestions and the presentation of new smart methods.

Finally, Chapter 4 develops extensively the findings regarding the subject of this thesis, as well as suggestions for further investigation.

Chapter 5 will demonstrate the performance of utilizing hybrid pavements which detailed analyses feasibility by using Abaqus software and cost analyses.

Chapter 6 will summarize the research outcomes of the thesis.



PART 2

LITERATURE REVIEW

The concrete pavements are mainly called the rigid pavement and made up from Portland Cement Concrete (PCC). It has or has not a base course between the pavement and sub grade. Due to its high modulus of elasticity, the concrete pavement tends to distribute the applied load on relatively wide area of soil. Therefore, the slab itself provides the greatest part of structural capacity. This is in contrast with the flexible pavement where building up the comparatively thick layers from of the base, subbase and wearing course carries the pavement power. There are many benefits that make the concrete pavement better than the bituminous pavement. Little of which have more beneficial life, deliver good visibility for night driving, less cost of maintenance, as well as, it needs little amount of aggregates and without flame. Thus, it is more suitable for the environment and can be constructed under unfavorable soil circumstances and practically unaffected by temperature and weather. Moreover, it provides better performance than the flexible pavement. Nevertheless, the high cost is considered one of the main drawbacks of rigid pavement. By taking into account the several functions and operational benefits and from all above viewpoints of life cycle cost, the cement concrete roads became common around the world. The emergence of new technique in the durable concrete production, increase the price of oils and before everything the participation of private sector in the development of infrastructure of roads made the selection of pavement in many high level road projects are high that constructed participially under the Build–operate–transfer (BOT) concept. The literature reveals that the long life benefit is widely positive for private sector projects where the period of rent reaches to 30 years. The investor expects that his project continuous for complete period without the need to many repairs or rehabilitation [9].

Nevertheless, the bituminous pavement that constructed carefully requires periodic renewals when the functions of the pavement is functionally and structurally deteriorated. This may occur each 7 years as existed in actual care [10].

Currently, decrease the maintenance works especially on crowded roads is considered one of the main concerns of traffic management procedures. Three elements must be taken into account in flexible pavement:

- The model of structural theoretical response.
- Properties of materials.
- External circumstances (environmental conditions and traffic loading).

The theoretical structural response model has been developed in order to study the response (stress, strain deflection) of pavement under the traffic load based on the mechanical continuum method. At some critical locations, response are used to analyze the pavement. For example, the horizontal tensile strain can be used in the bottom of asphalt level in order to predict the fatigue failure in asphalt [11]. The compression strain at the top of intermediate layer is used to forecast the rutting failure [12]. Figure 2.1 shows the critical locations of pavement structure.

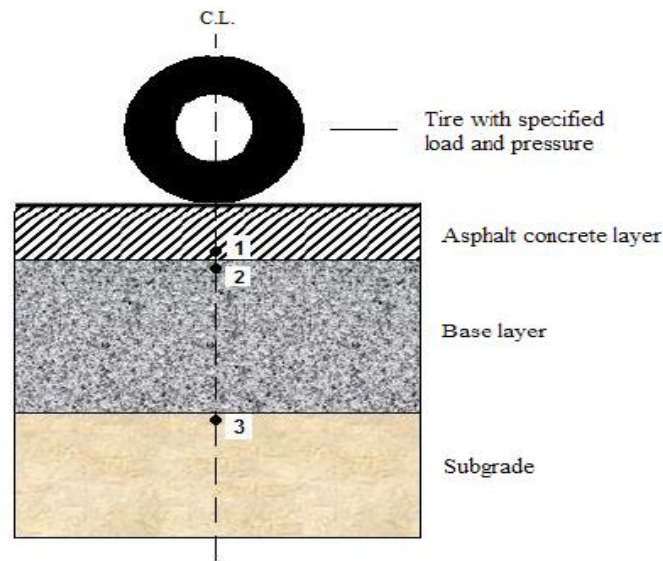

1. Horizontal tensile strain at the bottom of asphalt layer, used to predict the fatigue life of the pavement structure.
2. Vertical compressive strain at the top of base layer, used to predict rutting failure in the base layer.
3. Vertical compressive strain at the top of subgrade, used to predict rutting failure in the subgrade.

Figure 2.1. The critical locations of pavement structure [11].

The properties of materials consist three sides: the relationship of strain and stress, degree of recovering the strain after removing stress, time and temperature and time dependency of strain. According to these sides, it is possible to describe the materials to linear and nonlinear, plastic or elastic, viscous or non- viscous. The external circumstances consist the traffic movement of pavement and environment circumstances. They are considered the two main distress mechanisms that effect on the performance of pavement. In the structural analysis of pavement, moisture and temperature are the two most significant environmental factors. For instance, the thermal cracking is a result of temperature influence on pavements. Generally, it occurs with the extremely low temperature through the winter season. Also, the stripping is a result of interaction between the moisture and asphalt binder-aggregate adhesion [11]. Our study focuses on the theoretical structural response models for pavement analysis. The environmental conditions will not be considered, and the properties of the materials are assumed to be linear elastic. In the following sections, literature is reviewed on the available structural response models for flexible pavement.

Long and Shatnawi (2011) studied the structural performance of the experimental rigid pavements that constructed in state of California. The investigational project comprises seven Portland cement concrete pavement sections with many layer structures. Falling weight reflect meter has been used to perform deflection test for back calculation of layer module and subgrade reaction module, assessment of joint load transfer capacity and detection of spaces below the slabs. Moreover, condition of pavement distress has been assessed as it associates with the integrity of pavement structure. The main results in this study reveal that thick slab and lean concrete base lower the pavement deflection response and prevent the formation of voids under the corners of slab, but lean concrete base has no important impact on values of subgrade reaction module [12]. Patil et. al (2012) showed a numerical iterative procedure depending on finite factor approach to analyze the pavements response [17]. The beam elements were used to discretize the pavement. The Pasternak's two parameter soil medium models the foundation. The soil structure in interaction was taken into account in the analysis. A parametric study had been conducted in order to understand the response of pavement. Cojocararu et.al (2013) provides that in postdoctoral study. After providing a short introduction about the actual status of the structural design of airport pavements, the model and structural design of airport rigid pavement that built with the traditional and numerous recycled materials by the use of finite element approach has been described [18].

The main goal of that study is to provide a design approach in addition to the complex landing gear comprising six footprint tires. All determined factors associate with recycled materials and compacted concrete techniques are included. At the end, they presented the practical design diagrams for the structural design of concrete slab comprising their exact correlation function that utilized in the construction of the Airbus-A380 Plane runway. Maharaj and Gill (2014) conducted analysis to axisymmetric finite elements by changing the parameters of pavement pressure and the elastic modulus of subgrade [25]. The concrete pavement was idealized as linear elastic whereas the subgrade has been idealized as nonlinear material by Drucker-Prager yield standard. Four noded isoperimetric finite elements are used in order to discretize the pavement and subgrade. Number of design charts which have been developed are four. The literature states that very little literature was reported on

design charts rigid pavements. At the following section, we will discuss important design charts. Portland Concrete Association Approach Portland Cement Association developed design charts for rigid highway pavements depending on the formulae developed by Pickett. The design charts of unprotected and protected corners are depending on the procedures developed by Pickett to the design of highway pavements.

Hadi and Arfiadi (2001) provided a formula to the problem of optimal rigid road pavement design by discovering the goal function that is the total cost of pavement material and the entire control that effect the design. The optimum design is found by the use of genetic algorithm. The results which have been gotten from the genetic algorithm are compared with the results gotten from Newton-Raphson based optimization solver [26].

Westergaard's (2007) analysis has been used to design the rigid pavement. Westergaard's theory is sued to determine the stress in concrete slab. Westergaard saw the rigid pavement as a tinny elastic plate resting on the soil subgrade. The deflection of slab relies on the stiffness of the subgrade and the flexural strength of the slab. Therefore, the pressure-deformation features of the rigid pavement rely on the relative stiffness of the subgrade and slab. Razouki and Al-Muhana (2005) were developed charts of stress for the rapid determination of maximum bending tensile stresses in case of the concrete pavement slab on a Winkler foundation. The greatest bending moment of the concrete pavement signified by a Westergaard slab on Winkler foundation was gotten logically by covering the known solution for the case of a consistently loaded circular segment to the case of multiple circular contact regions. The scientific paper shows that the impact of the maximum bending tensile strength are very important because of the subgrade reaction modulus, modulus of concrete elasticity and thickness of slab [28].

Gill and Maharaj (2014) provided analysis to axle symmetric finite elements that has been performed by changing the parameters the pavement thickness, pressure and subgrade elastic modulus [25]. The pavement of concrete was idealized as linear elastic material whereas the subgrade was idealized as nonlinear material by

Drucker-Prager yield standard. Subgrade and pavement were discretized by four noded isoperimetric finite factors. The first type of design diagram has been drawn between thickness of pavement and nodal deflections for numerous pressures for a specific elastic modulus of soil. The second type of diagram has been drawn between the thickness of pavement and factor stress for numerous pressures for a specific elastic modulus of soil. The third type of design diagram has been drawn between the thickness of pavement and nodal bends for numerous elastic modules of subgrade for a specific pressure. The fourth type of design diagram has been drawn between the thickness of pavement and element stress for numerous elastic modules of subgrade for a specific pressure. Each design diagram consists of three elements. For two identified elements, the third factor can be gotten. The developed designed diagrams, the impact of thickness, elastic modulus of soil and pressure on nodal deflection and element stress has been investigated [25].

2.1. AASHO ROAD TEST PROJECT

For many years, The American Association of State Highway Officials(AASHO) faced problems of pavements construction in order to carry growing traffic load and creating a reasonable policy for vehicles weight and size. Thus, procedures have been placed to start and manage the research projects that mutually financed by two or more countries in September 1948. Before testing AASHO road, two main test projects have been performed because of the need to factual data associate with the effect of axle loads for numerous magnitudes on pavements. The first test was on Maryland Road in 1950 that was published as Highway Research Board [20]. The second test was on WASHO (Western Association of State Highway Officials) that was performed in 1953-1954. The results of these two reports have been published as Special Reports [23, 24].

In March 1951, the Mississippi Valley Conference of State Highway Engineers started the planning for a third local project. This matter had not been accepted because it had not worth of spending time and money on other test of partial extent. So, there was a necessity for arranging broader test project. In February 1955, the Highway Research Board approved on the responsibility to manage and direct the

new project. After a good revision on the proposal submitted by the research board, AASHO informed that test road project will be implemented. In July 1955, the field office is opened in Ottawa, IL. The test facilities started in August 1956. The test ended in November 30, 1960 where at this time up to 1,114,000 axle loads has been applied on the bridges and pavements. In 1961, the research team analyzed the data and prepared reports regarding the test. The project team finished all reports and provided to executive committee of the board. Later, in January 1962, the field office has been closed [21].

At the following step, we will explain a part of the formal statement of the intent of the AASHO Road Test project where it has been accepted the executive committee of the Highway Research Board [21]:

The road test of AASHO plays a major role in engineering and economic process of offering highways for the nation. It is significant to understand this part. The test is composed to separate main experiments. One of them associate with asphalt concrete (AC) pavement and the other associate with Portland cement concrete (PCC) pavement, and one associate with the short span bridges. As well as many secondary experiments are included at this project. In each of the main projects, the main goal is to associate the design and performance under precise loading circumstances.

In the experiments of Portland and AC cement concrete, many pavement test sections were under the design while other were over designed. Each of these experiments needed a separate analysis. At the end, it was necessary to collect and analyze the additional economic and engineering data related with local environment in order to develop a final and meaningful relationship between different types of pavements. At each experiment, establishing distress and failure of the pavement test fields are significant for the success of each experiment.

With the development of total engineering and economic process to provide highways for the country, the engineering data from the road test of AASHO will flow from many other resources to the sponsor and its member departments. From this point, studies will be performed, and data will be extracted which may be helpful

for the legislative and executive branches on different levels of our government, managers of highways and engineers.

2.2. OBJECTIVES OF AASHO ROAD TEST

The National Advisory Committee mentioned many objectives of AASHO road test and these objectives can be described as follows [22]:

- In order to determine the important relationships between number of repetitions for specific axle loads of different arrangements, magnitude and performance of different thickness of normal asphalt concrete, plain Portland cement concrete, and covered Portland cement concrete surfaces for different thicknesses of bases and sub bases on a basement soil of identified features.
- In order to determine the important effect of particular axle loads and total vehicle loads when they applied with known frequency on bridges with known design and features.
- Conducting special studies address many subjects such as base types, pavement exhaustion, paved shoulders, size of tire and pressure, military vehicles, and to relate the results of these special research with the results of the main research results.
- In order to offer a record for type and extent of effort and necessary materials to keep each of the test sections or a part in satisfactory case until stopped for test issues.
- In order to develop tools, procedures of test, data, diagrams, charts and formulas. This reflects the capabilities of different test departments which will be beneficial to design the highways in future, assess the load capacity of current highways and to determine the most promising areas for more highway researches.

2.3. BACKGROUND HYBRID PAVEMENT

It was difficult to obtain documents associate with hybrid pavements. However, we found one of the scientific papers that discussed the paving concrete "traffic" and

asphalt junction in addition to another scientific discuss the Rutting Prediction use Abaqus software to analyze the problem. Other scientific papers use other programs in order to analyze the asphalt and the effects of load and an attempt to know the reason of asphalt failures and the emergence of deteriorations. We could not find scientific papers about the hybrid pavements regarding our research. The scientific papers we found that associate or close to our research subject are summarized below:

- David Lozach 2003 This guide outlines the advantages of using concrete and explains the characteristics one meets to design and achieve the rotor with this material. It suggests types and shapes of structures, methods of their realization and advice for following up work and maintenance. It shows how successful the use of concrete in traffic rotors and its suitability to withstand the loads and stresses that occur to the pavement layer, especially that when the vehicle spins, the weight on one of the wheels increases over the other in the same load axis [15].
- Al-Khateeb, L. A., Saoud, A., & Al-Msouti, M. F., (2011) ,two-dimensional finite element model was developed by using ABAQUS software, With a view to investigate the effect of static repeated wheel load on rutting formation and pavement response. The procedures were building a model and performing static analysis are introduced. The research investigated the effect of temperature, tire pressure and subgrade strength on the rut depth as a pavement response. The sensitivity analysis was indicated that the rutting depth increases with increasing the temperature and the tire pressure and with decreasing the subgrade strength [34].
- Alaa H. Abed and Adel A. Al-Azzawi (2012), The aim of the research was to predict the depth of rut in flexible pavement. The performance of pavement was the process used to estimate parameter values related to pavement structure, and traffic load and environmental conditions .it was used the Finite Element Analysis through ANSYS software is used to analyze two-linear elastic plane strain problems with elements (Airplane 82). From the results, it became clear that despite the 14% decrease in stress level and the leveling course as well as 27% in the basic training course, and the depth of the path

increased by 12 and 28% in those layers, respectively, due to a change in material properties [38].

- Ganesh Borude, Vijaykumar Bhusare (2017), The analysis of flexible and rigid pavement is complicated, because of the system of the pavement is multilayer and it is three dimensional. In order to provide accurate displacement, strain and stresses, the system have to consider the different characteristics of every layers. The research investigated the behavior of the flexible and rigid pavement under transient pressure using finite element analysis ABAQUS. This research shows the impact of increasing of pressure with time on deflection, stress and strain in rigid pavement and flexible pavement. The results showed that the deformations that occurred in the flexible pavement were more than the rigid pavement because of the applied pressure. So observed the stresses generated in rigid pavement is 30-35% greater than flexible pavement when pressure is applied .Due to applied pressure the strain developed in flexible pavement is 50-55% more than rigid pavement .We observe from analysis that thickness of flexible pavement and rigid pavement also effect on the strain, stress and deformation of pavement [35].
- In the city of Hamilton in Canada , Concrete Ontario has removed the flexible paving in the traffic light position due to road deformation and occurrence of a groove of approximately 3.5 cm. Work had begun to remove the flexible pavement and then punctured holes in the part between the roads and link it to tie bar installation and ground soil was compacted well then install the dowel baskets in the holes, then maturity wire installation and then pour the concrete and level it and open the way after 16 hours. These works were implemented in 2014 as show in Figure 2.2 [78].

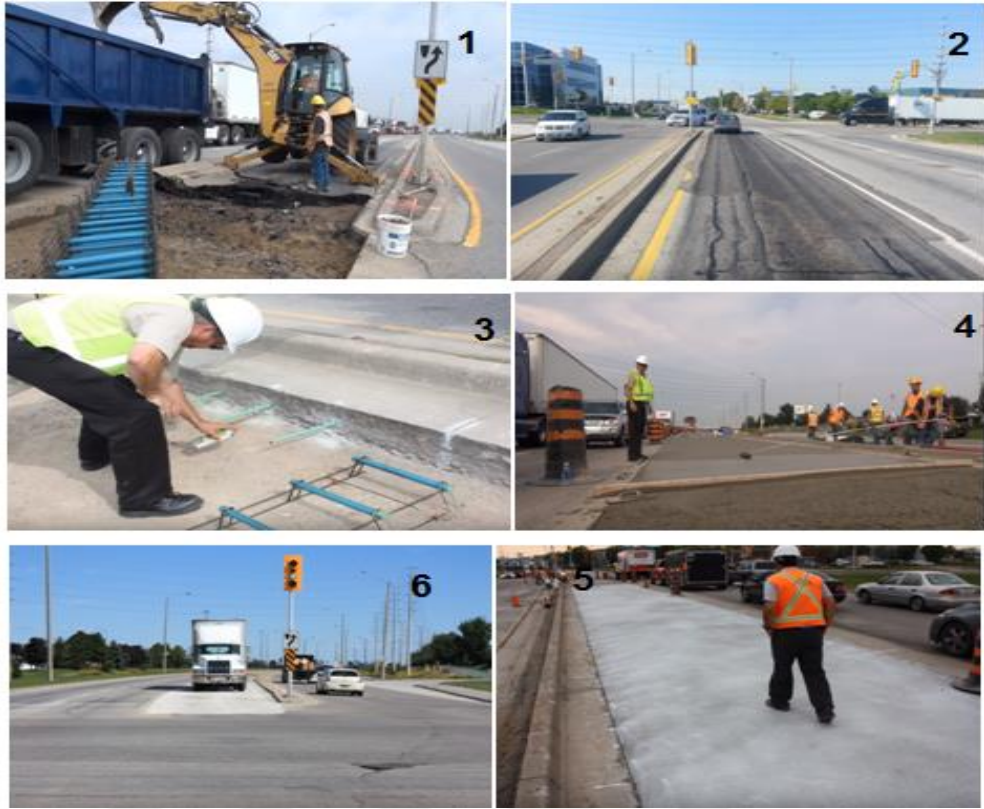

Figure 2.2. Practical experience to replace flexible paving with other rigid pavement in a City of Hamilton [78].

PART 3

THEORETICAL BACKGROUND

When determine the surface circumstances, establish a diagnostic to the problems and select the most suitable treatment of maintenance, the accurate description of pavement surface configures great importance. The explanation must be understandable for all and it is necessary that all concerned engineers with maintenance of roads have mutual language to describe what they detect on the surface of the road. These requirements motivated many countries to create catalogues about the deficiency of road surface. Nevertheless, it is not enough to prepare a descriptive menu, but it is necessary to classify the different types of shortcomings and list the most suitable treatments. It is important to create a similar inventory of road surface defects in line with the methods followed by the other countries.

3.1. PAVEMENT TYPES

Depending on design considerations, and the way which loads are distributed on subgrade, there are two types of pavements which are rigid pavement and flexible pavement. [14] as shown in Figure 3.1.



Figure 3.1. Flexible pavement and rigid pavement [47].

Before differentiating between rigid and flexible pavements, it is necessary to know the characteristics of each one of them. Figure 3.2 shows the difference between rigid and flexible pavements in details.

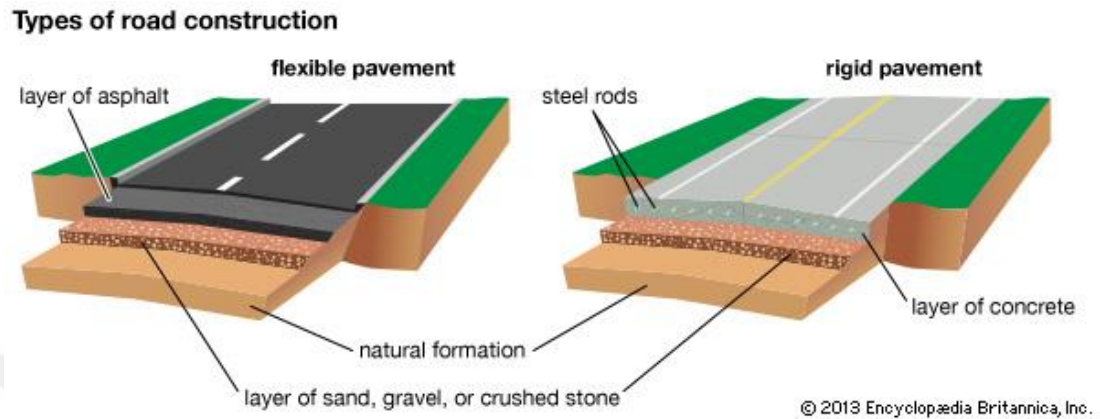

Figure 3.2. The differentiate between flexible and rigid pavements [48].

3.2. FLEXIBLE PAVEMENTS

Flexible pavement comprises from substrate layer, basement layer and surface layer of asphalt material. In general, bitumen materials of bituminous and viscous characteristics which permit large deformation of plastic. In spite of that some asphalt surfaces are built at "full depth" directly, most of asphalt surfaces are built on a base of gravel. Hot Mixes Asphalt (HMA) are as tempered, hot asphalt or cold asphalt mixture. This is known as pavement and it reflects the general deviation of the entire following layers for the traffic burden. The design of flexible pavement depends on the properties of layered system. The flexible pavement loads a reasonably small area of substrate load. The cost of initial installation for flexible platform is lower than the rigid one. Therefore, these types of pavement covers are considered to provide a money of construction. Nevertheless, the flexible roads need a routine maintenance each few years. Moreover, the flexible road surface is quickly decreased, drilling and cracks may arise because of the poor drainage and heavy traffic movement. The quality of materials used, and materials of flexible items can be categorized into two types. The high power is used near the surface or surface is mainly desired. Therefore, the lifting force is delivered to the pavement. Generally, it

influences on the thickness of flexible pavement. Figure 3.3 shows the components of flexible pavement [48].

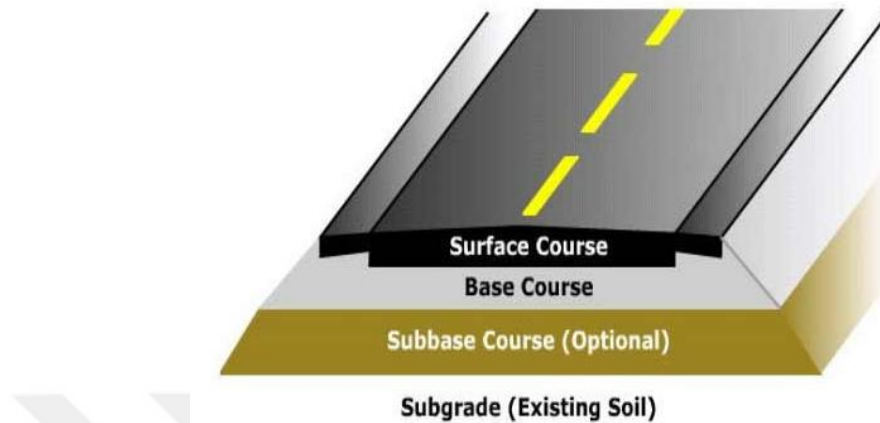

Figure 3.3. Flexible Pavement Cross Section [49].

The main benefit of flexible platform is that it can be open through 24 hours of completion. In terms of price, flexible and adjustable fasteners are cost-effective and easy. The figure of flexible pavement consists of four layers. The surface course is hard and adequately strong to persevere the heavy machine pressure especially the vehicles that move over it. As well as, it has been designed in order to display waterproof abilities and to get appropriate smooth surface for both skid resistance and good driving performance. The second layer is base layer and it is simply known as base layer. The third layer is consists of smaller crushed stones and other substances such as these that mostly granular. The subbase layer is below and serves the purpose of the pavement stabilization. The subgrade layer is the last layer and it consists of natural substances and deliver increased strength [49].

3.3. LOW STANDARD FLEXIBLE PAVEMENT

The pressure is reduced by spreading the load of tires on wider area of the road. Generally, the flexible pavement has many layers with the stress-distributing properties. The design of flexible ceiling uses a concept of layered system. Surface of flexible road uses the concept of layered system. it may install in many layers and the upper floor must have best quality in order to preserve the maximum pressure and

upper layer of the compressor. The bottom layer faces less amount of pressure and it can be used with materials of low quality. The flexible platform is constructed with the bitumen materials. These can be the form of surface treatment (for example, asphalt surface treatment initiate from low standard methods), or the layers of concrete asphalt surfaces (that can be used in high-capacity roads, generally with the national roads). The thick layer reflects the substrate deformability over the surface. In case of flexible collision, the design will depend on the total performance of the flexible platform and the resulted pressure must still less than the allowable pressure for the total floor of pavement. Thus, low standard or low-quality layers are preserved under the surface and the other on near or at the surface. This helps an effective management of pressure and loads in different parts of the pavement. Figure 3.4 shows the structure of pavement [50].

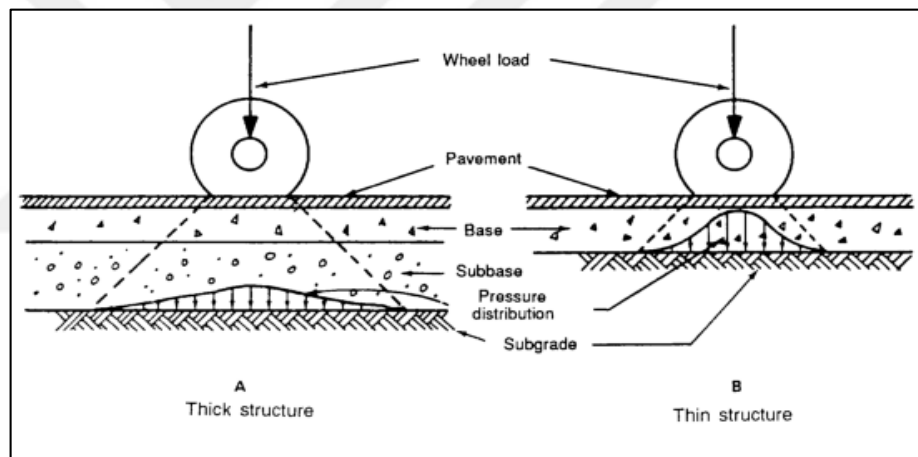

Figure 3.4. Load distributions occurring in superstructures [50].

3.4. HIGH STANDARD FLEXIBLE PAVEMENT

The high standard flexible pavement includes the use of expensive raw materials in order to construct the pavement and offer stability. It is possible to use different types of materials for manufacturing. The surface of conventional flexible road consists of many layers where high expensive raw materials are placed on high levels of stress with low quality and unexpansive materials. Instead, complete pavement of asphalt is created by inserting the layer of asphalt directly on the ground floor. This is more suitable when traffic is heavy and there is no local material available. In addition,

built-in asphalt cover has been built by inserting thick dense layer between two layers of asphalt. The improved asphalt concrete is inserted on the base that expressively decreases the vertical compression soil pressure and inhibits surface water. The bituminous layer is also called bituminous surfacing and improves the pavement. It has been constructed by taking into consideration the general traffic circumstances and the temperature of the region or the external environment constructed upon. The carpet thickness reaches to 25 mm and Surface treatment must not be counted in the total thickness of the road. The main goal of flexible pavement with high standards is to decrease pressures transferred because of tire loads where they do not exceed the bearing capacity of subgrade [49].

3.5. FLEXIBLE PAVEMENTS DEFECTS AND THEIR REASONS

It seems that flexible pavement is an effective mean for road construction particularly on highways which give an idea about low manufacturing cost but there are both compete in the image. It is possible to use flexible pavement in some sides where it proves that it is not harmful in other sides [49].

3.5.1. Advantages of Flexible Pavement

At the following steps, it is given briefly the advantages of flexible pavements [48]:

- The cost of constructing flexible pavement generally is less than cost of rigid pavement.
- It is considered a type of construction more specifically denoted as phase construction.
- It is possible to perform change or maintenance easily.
- It is possible to manage the consumption of oil efficiently due to the smooth roads where vehicles do not face any type of resistance during the movement which promote the use of oil and lead to better condition.
- When we mention the smooth construction pavements, there is a less chance for torn or damaged tires because the effect of resistance is less that effect on tires and give better period of life.

3.5.2. Disadvantages of Flexible Pavement

The disadvantages of flexible pavements can be summarized as follow [48]:

- It decreases the power on roads. As well as this need more layers of support. Lower power is limited too.
- It prevents drainage and pores though the construction during the road life. The weakness of the additional time of drainage may lead to decrease the durability of pavement and give shorter life.
- it requires continuous maintenance. Moreover, the cost of maintenance is high which make the pavement is costly program.
- Under heavy traffic as in the case of highways, the flexible pavements do not prove to be much fruitful and have a rather low life span.

3.5.3. Failures in Flexible Pavements

Flexible pavements suffer from different types of failures. The determination of this failure and its reason is necessary to facilitate the correction in the design and construction mix for future projects. At the following parts, we will discuss the exposure that influences negatively on pavements [48].

3.5.3.1. Weather Conditions

Weather change causes distresses in flexible pavements as shown in Figure 3.5.



Figure 3.5. Change in weathers on pavement [51].

3.5.3.2. Use of Chemical and Salts in Colder Climates

The frost and asphalt stripping because of ice and snow causes potholes and other distress as shown in Figure 3.6.



Figure 3.6. using the salts in snow climates Causes damage to the road [52].

3.5.3.3. Ultraviolet Rays

The ultraviolet rays make pavement suffer from oxidation and causes its fragility. In a sunny day, the temperature may reach into 140c°. This point is softening the liquid asphalt. This temperature degree makes the pavement expands and move. Figure 3.7

shows the change of climate involving the ultraviolet rays. The pavement is contracting when the temperature decreases. The contraction and expansion are considered the main reasons of initial cracking.

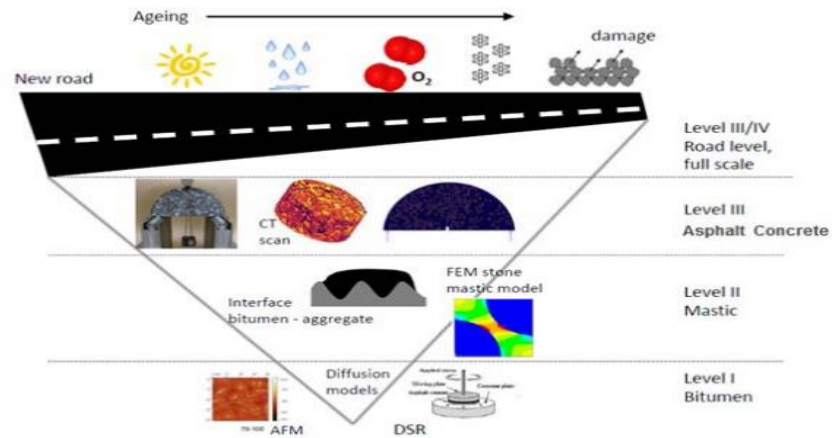

Figure 3.7. Show the change of the climates including ultraviolet rays [53].

3.5.3.4. Water (Natural Rain and Irrigation)

Water will penetrate to the base and subgrade which cause structural damages in the pavement as shown in Figure 3.8.

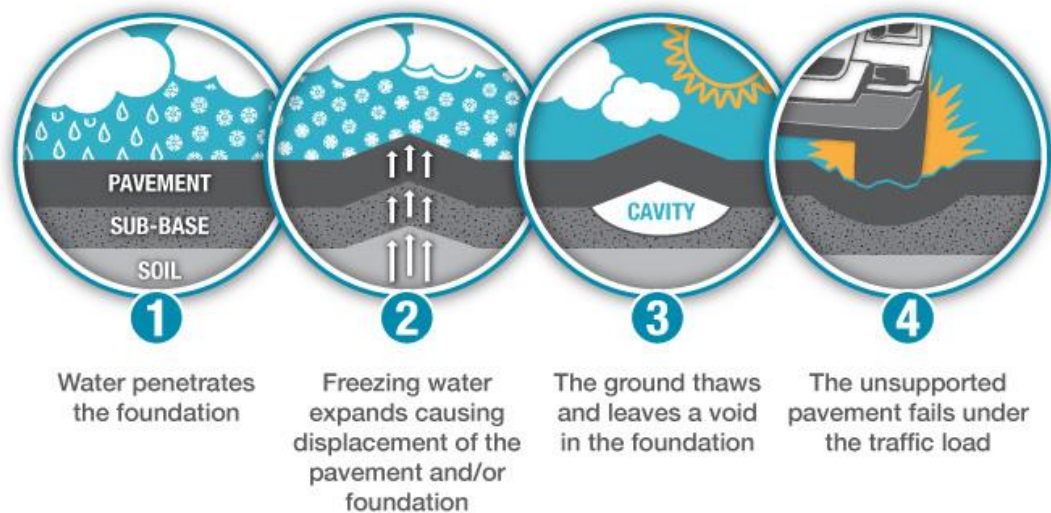

Figure 3.8. water can enter to the base and the subgrade [54].

3.5.3.5. Vehicle Loads and Petroleum

The safety of pavement is deteriorated by the fuel spillage coming from cars. The raises the binder softening point. The parked vehicles have more opportunities on leaking the gasoline or brake fluid which make the asphalt liquefy. This will make the binder separates from the rock which may generate softer regions. Therefore, it is necessary to not neglect the sudden treatment of oil spots on the parking regions.

3.5.3.6. Aging of Flexible Pavements

The pavement is going through a life cycle. It leads to cracks formation and accelerated oxidation. The small deterioration in the initial phases help to decrease the aging impact of intensity. Furthermore, exposure to ultraviolet and temperature increases the deterioration degree.

3.5.3.7. Alligator Cracking of Flexible Pavements

Alligator cracks are also named as map cracking. It is noticed the existing of associated series. The tensile stress is the greatest at the asphalt surface (base). This is the location where cracks are configured which is the region with maximum distress. A parallel of longitudinal cracks propagates over time and access to the surface. The repeated loading and the concentration of singular cracks will help to get connected. This will look like the chicken wire or alligator skin. This is called the alligator cracking. As well as it is called crocodile cracking. These cracking is noticed only in regions where traffic load are repeated. Alligator cracking is considered as one of the main structural distress. Then, this distress is conveyed by rutting. The alligator cracks formed in pavement are shown in Figure 3.9.



Figure 3.9. Alligator cracking [55].

3.5.3.8. Depression Distress in Flexible Pavements

The pavement has specific areas own less height as compared with the level of surrounding pavement. The existed lowering in the pavement are the depressions. In general, they are notified only when filled by waters. Depressions exist in flexible pavements are very popular and they are found in parking areas and overlays. The reason of these depressions whether by settlement of foundation soil because of the continuous loading or they may be configured during the construction phase. Figure 3.10 shows an example about depressions in flexible pavements [55].



Figure 3.10. Depression distress [55].

3.5.3.9. Shoving

Shoving can be described as a form of plastic movement which can be seen in the wave form. In addition, they are perceived perpendicular to the direction of the traffic. An example of shoving is clarified in Figure 3.11[55].



Figure 3.11. Shoving [55].

3.5.3.10. Longitudinal and Transverse Cracking Distress

This type of distress is either environmental or structural distress. The longitudinal cracks are formed parallel to the pavement alignment or the center pavement line. Figure 3.12 and Figure 3.13 show example of longitudinal cracks and transverse cracks respectively [55].



Figure 3.12. Longitudinal cracks in asphalt flexible pavement [55].



Figure 3.13. Transverse cracking in asphalt flexible pavement [55].

This type of cracking is a fatigue crack. Thus, the cracks happen in the traffic flow direction. The transverse cracking occurs perpendicular to the pavement direction. This causes the thermal crack [55].

3.6. RIGID PAVEMENTS

This type of pavement is built from the reinforced concrete slabs or cement concrete. Grouted concrete roads are of the type of semi-rigid pavements. The design of rigid pavement depends on offering a structural cement concrete slab with adequate strength in order to resist loads caused by traffic. It has high modulus of elasticity and rigidity on distributing the load on proportionally wide region of soil. The load distribution on the slope determines the difference between the highway surface and steel. The rigid pavements include reinforced concrete plates or cement concrete. The rigid pavements are fortified by solid concrete coating. The structural concrete tiles of rigid pavement determine its design and provide adequate strength for load of traffic. The solid platforms provide high elasticity rate and rigidity to distribute the load proportionally on large area. Figure 3.14 shows a sample of rigid pavement cross section [56].

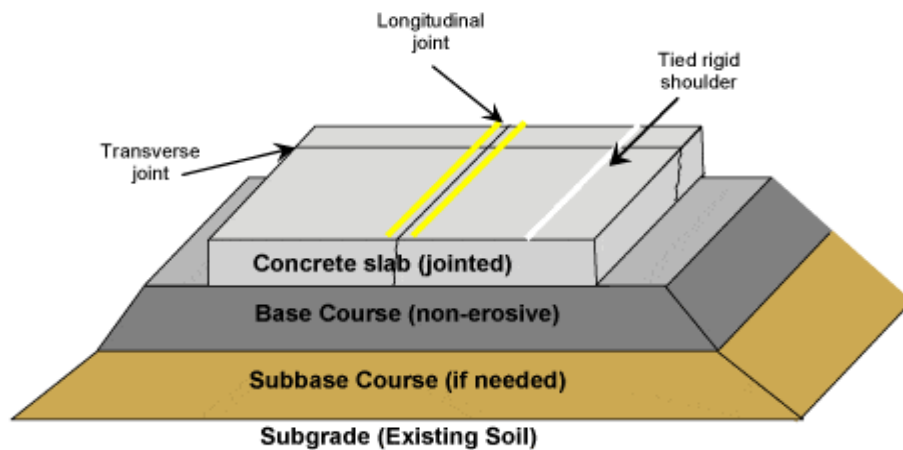

Figure 3.14. Cross section of rigid pavement [56].

The small changes in the bottom layer strength provide little effect on the hardness of solid gutters. The tensile strength in the design of rigid platforms is not the strength of subbase but the main element. As a result of this feature in the road surface, when drag down on the surface of the hard road, the floor of concrete may close where the tail is defective because of the local deficiency and plate movement. The concrete cover configures a thermal pressure because of the tile's temperature. The previous reason causes tension and the second one causes the friction pressure. The main floor should be used to offer structural advantages under the solid berth depending on the economy of construction. The major initial costs are generally low thick thickness rate offers a thick base. Nevertheless, there are basic core courses costs of maintenance can normally be decreased as thick databases offer strong support the foundation therefore decreases the movement of the tile. [56].

3.6.1. Types of Rigid Pavements

The rigid pavements are divided into four types in addition to fifth additional pavement. The names of these four types are the jointed reinforced concrete pavement, jointed plain concrete pavement, pre-stressed concrete pavement, and continuous reinforced concrete pavement. Each of these four types are designed according to special standards. The special type between these types is the roller compacted concrete that will be discussed at the following steps.

Rigid pavements can be classified into four types and special type between these types:

- Jointed plain concrete pavement (JPCP).
- Jointed reinforced concrete pavement (JRCP).
- Continuous reinforced concrete pavement (CRCP).
- Pre-stressed concrete pavement (PCP).
- Roller compacted concrete (RCC)

3.6.2. Jointed Plain Concrete Pavement (JPCP)

This type of pavements are generally concrete hills consists of spaced contraction segments. The joint gates or screws are normally used to transfer the loads between the joints. The interval is 5-6 meters (15-20 ft). The freeways and transport in the United States use the payloads made from the associated normal concrete platforms or (JPCP). A device named a pin spreads the layers of a series of continuous concrete slabs. Subscriber allowance, movement and distortion of road surface under the mechanical load and heat change. The joints may be perpendicular or parallel to the traffic (Cross-sectional) (longitudinal joints). Distinctive problems are associated with concrete berths or associated with non-load conveyors that consist pumping, faults, and corner breaks. Presently, the diameter of steel nails that are typically epoxy resins, is 2.54 or 3.81 cm (1.0 or 1.5 inches) and length 45.72 cm (18 inches) are being extensively used in JPCP. Nevertheless, before the installation of this cover, it causes the deterioration and pin corrosion. JPCP controls the location of predicted natural cracks. The entire cracks appear in the sewing and not in any parts of the tiles. In the construction of normal JPCP, the joints which to be articulated are constructed by take into consideration the moisture and temperature elements. So, with time when these circumstance change, more cracks will not be created. Generally, there are two types of joints are created. The first called the tie joint and constructed in the longitudinal side and the other is called the dowel joints or dowel bars and located on the transverse side. Figure 3.15 shows a cross section of jointed plain concrete pavement [57].

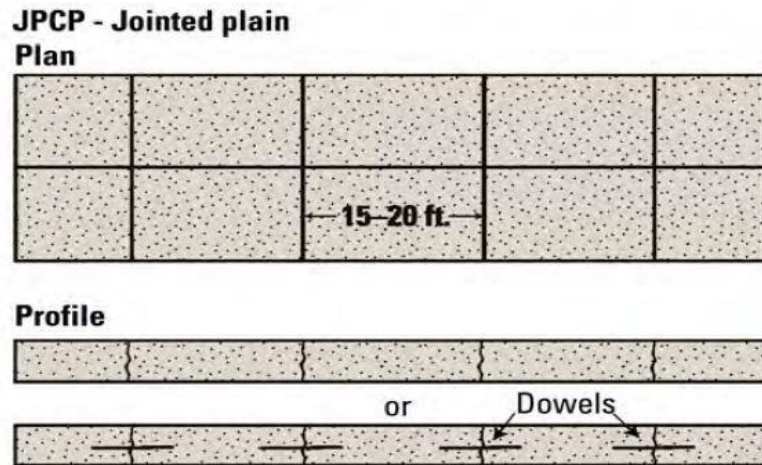

Figure 3.15. Cross section of (JPCP) [57].

3.6.3. Jointed Reinforced Concrete Pavement (JRCP)

JRCP consists armature stamps which sometimes called as distributed steel. The manufacturer company in JRCP, intentionally increasing the contact range and always the joint pavement is made from steel in order to offer intermediate panels. The distance that existed between the crossings of joint is typically 9 meters (30 feet) or even more in some cases and some machineries use up to 10 meters (30.5 feet). Through the countries systems, many JRCP organizations have been established in central and western of America. Currently, this design is adopted by many companies only due to the performance problems caused by cracks broken steel breaks. In spite of that the regulatory capabilities do not enhance the structural efficiency, they increase the distance from 10 to 30 meters. One placement bar is demanded in cargo transmission. It works on stabilizing the dampened materials after the cracking [57].

The cracks development at concrete slops is considered a complex issue. It is necessary to know that these cracks are caused by contracts and contributions, special contraction, applied and enhanced twist. These elements must be known. The proper use of joints and / or steel rods can easily control the natural cracks. In general, a joint reinforced concrete pavement is considered helpful over the JPCP because it results in less cracks than the JPCP. This because that reinforcement

preserves the cracks and portion of joint intact for longer period of time offering great stability to pavement of roads. Figure 3.16 shows cross section of joint reinforced plan [57].

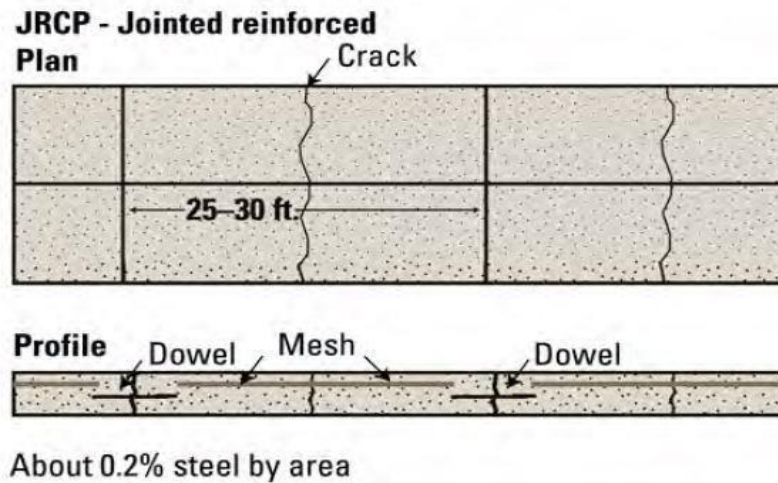

Figure 3.16. Cross section of (JRCP) [57].

3.6.4. Continuous Reinforced Concrete Pavement (CRCP)

CRCP can be defined as a concrete cover which does not need any intrusion. The length of cracks in tiles are expected to be between 0.5 to 1.8 meters (1.5 and 6 feet). The CRCP is designed with an appropriate amount of greater reinforcement (roughly 0.6-0.7% cutting area) in order to keep the cracks tight. Determine the suitable interval between the cracks in this type of pavements is a part of the design process. CRCP design is more expensive than the designs of JPCP and JRCP because of increasing the amount of steel. Nevertheless, the excellent performance may refer to the long-term starting from 30 to 40 years of design life and cost efficiency. Several airlines companies have selected to use the design of CRCP in corridors, repeat strong city traffic, over a set of these awards can be avoided through the course of the road. CRCP is considered a well selection to recur the concrete asphalt which decrease the weight and frequency of reflective cracks, reducing the vertical movement between neighboring steel welds and restrict the features narrowing the cracks. In order to remove the side welds which, help on keeping the cracks, CRCP uses steel bars to efficiently remove them. They are used beside other design

characteristics including concrete width and thickness in order to avoid vehicles and environmental threats. Due to increasing the constraints of steel, iron is added to the surface shorter than the spark plug in the conventional concrete cover. In general, the occasional cracks in CRCP are 1.5-6 feet away. Steel offers high pressure connection and helps in promoting the good transportation by locking the aggregates and with steel itself. Wear cracks provides other advantages such as less errors, decrease the potential of waters and more difficult output with damaging chloride and other abrasives. In summary, the durability and age of CRCP are increased by dense cracks. Figure 3.17 shows a cross section of CRCP [58].

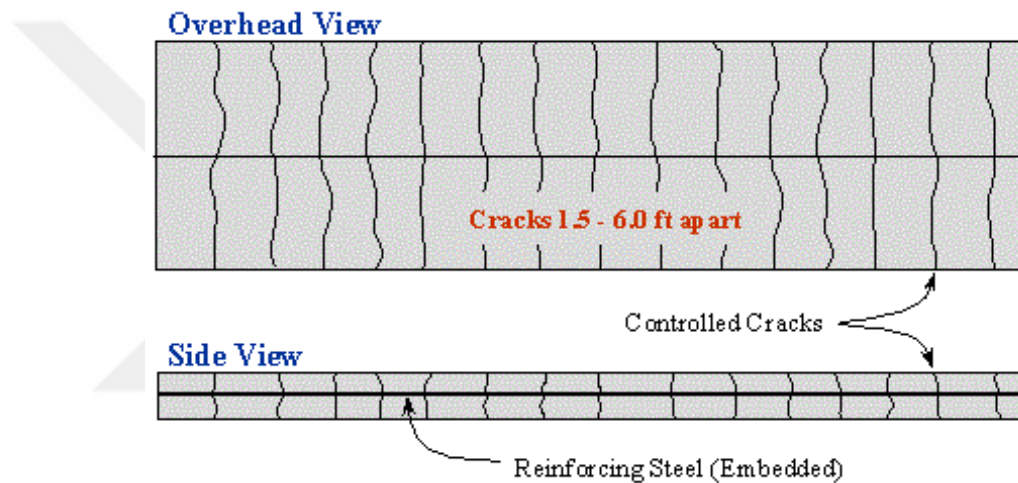

Figure 3.17. Cross section of CRCP [58].

3.6.5. Pre-stressed Concrete Pavement (PCP).

Accessing the concrete roads for the last 15 years has been perceived that the dock of airport is increasingly involved in American engineers and Europe for roads manufacture. The model of this new pavement region is generally associated with the ability to get two basic features of the conventional tree. The pre-stressed cover permits more effective use of construction materials in terms of the thickness of demanded pavement. It is possible to design by using low beams of pre-stressed pavers and have the capability to crack less than the conventional trees that can extend the age of shelf and decrease the repair requirements. The benefits of PCP involve the wide data performance, basic modes, construction methods are necessary

to study the current theory of design. It is necessary to develop effective standards in order to measure the dimensions, prestressed, reinforcement requirements with different basic circumstances. The joints that existed between pre-stressed tiles involve particular problems of design. They may generate numerous vertical and horizontal movements. Design vertical may have problems associate with construction and design [57].

There is no doubt that the use of continuous pressure of stress is increasing the concrete bending strength. This will be permitted under specific load circumstances, the road surface is little thin but the structural advantages of pre-tightening are limited on the flexible range of wide concrete. Therefore, the serious study of manufactured road is doubtful. Figure 3.18 shows a cross section of plain concrete pavement [57].

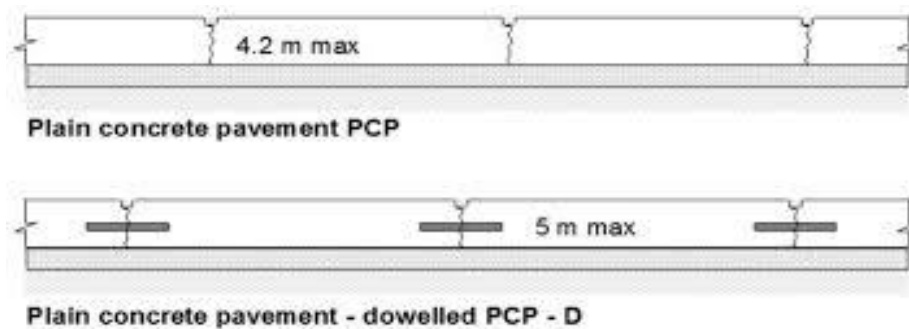

Figure 3.18. Cross section of PCP [57].

3.6.6. Roller Compacted Concrete (RCC)

RCC can be described as a concrete layer which does not consist on steel or compact conveyors and they are not usually connected placement methods. Pressure of clean RCC and general class comprising smaller amount relative to the traditional pavement regions are enhanced by increase the total load and ensure that RCC is loaded to the site of load. This type of concrete is faster than the conventional concrete because of well-defined dense aggregate pieces which deliver a robust improved over lock. RCC and overall mutual ratios permit to squeeze the sidewalk. In general, final pressure can be determined by mixing through 45-60 minutes.

Through the dam construction that extend from 1961 to 1964, the construction of the Alpe Gera dam started near Sondrio in northern Italy. The concrete uses similar approaches, but it does not wrap. At the seventies of the last century, RCC was named revolutionary materials to construct dams in engineering journals. Since the beginning, RSS was used to construct pavements fully of concrete floors but because of the large amount of concrete pouring led to less temperature, the content of cement and use of fly ash were better than the usual [58].

As a reverse of traditional bulk concrete dams, the compact concrete needs expense and significant time. These comprise higher concrete placement ratios, decrease the cost of materials, and decrease the costs of post-cooling costs and mold. Thus, RCC is considered a special mix of concrete with the same conventional mix of concrete but it replaces the Portland with alternative amounts and more. There is no doubt that it is a strong method of dam construction and it is used in construction of dams and pavement of high-level roads. Figure 3.19 shows a application of RCC [59].



Figure 3.19. A application of RCC [59].

3.6.7. Rigid Pavement Defects and their Reasons

Generally, rigid pavements have many advantages over the flexible pavements where they do not need into repetitive repairs and more durable than the flexible construction. Therefore, it is possible to say that the cost of repairing the rigid pavement is low. It has firm construction and strong edges and it is noticed that they are usually resistant for materials including grease and oil [48].

3.6.7.1. Advantage of Rigid Pavement

The rigid pavement has many benefits which can be summarized as follow [17]:

- It is noticed that the life of rigid pavement is very long, robust, and high strength over the long age.
- The concept of distributing load on wide area can be easily achieved through the rigid pavement and requirement of decreasing the base and sub grade can be achieved too.
- Rigid pavement offers an opportunity for entertainment and reappear with least efforts and cost. As well as it is experienced that rigid pavements can be created on soft and low soil which make it really useful.

3.6.7.2. Disadvantages of Rigid Pavement

Rigid pavements have many disadvantages which can be summarized as follows [48]:

- The common difference between flexible and rigid pavement is that rigid pavement includes a unified structure while the flexible pavement includes layers of pavement and materials with better quality on the surface or near it.
- In spite of that rigid pavements need less maintenance but they suffer from high manufacturing costs in initial construction.
- Rigid pavements are rarely need repair or maintenance, but the cost of maintenance is very high and thus, this pavement program is durable but costly.

3.6.8. Failures in Rigid Pavements

Rigid pavements suffer from different types of failures. The determination of this failure and its reason is necessary to facilitate the correction in the design and construction mix for future projects. At the following parts, we will discuss the exposure that influences negatively on pavements [48].

- Joint Spalling
- Faulting
- Polished Aggregate
- Shrinkage Cracking
- Pumping
- Corner Break
- Punch out
- Linear Cracking
- Durability Cracking

3.6.8.1. Joint Spalling in Rigid Pavements

The deterioration in joints are caused by excessive compressive stress and it is called spalling. This may be associated with pavement growth or joint infiltration caused by reactive aggregates which is shown in Figure 3.20. Poor technique of construction and quality of concrete will lead to joint spalling. It is possible to notice small edges to large spalls in the back of slab and down to the joints can be noticed. Main reasons of joint spalling in rigid pavements can be clarified as follows [60]:

- Joints expose into high stress because of high traffic or by the penetration of any incompressible materials.
- Joint which have been constructed with the concrete is weak.
- Joint accumulated by water caused by quick freezing and thawing.

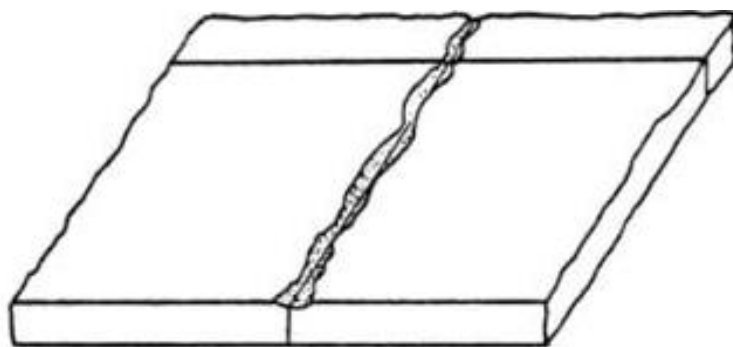

Figure 3.20. Joint spalling in rigid pavement slabs [60].

It is possible to avoid joint spalls by sealing joints or by using good construction techniques.

3.6.8.2 Faulting in Rigid Pavements

Faulting is the difference in elevation between joints and it can be seen in Figure 3.21. The main reasons of failures that occur in rigid pavements because of faulting can be summarized as follows [60]:

- settlement of Pavement which is caused because of the soft foundation.
- The erosion or pumping of materials under the pavements that lead to cause voids under the pavement slab producing settlement.
- The change of moisture and temperature which cause curling of the slab edges.



Figure 3.21. Faulting with difference in elevations at rigid pavement [60].

3.6.8.3 Polished Aggregate in Rigid Pavements

This distress is caused by the repeated traffic application. These types of failures are caused when aggregates above the cement paste in the case of PCC are very little or not enough. Also, these are caused when they are angular in shape that it cannot

deliver adequate resistance of skid for the vehicles. It is necessary to determine the degree of polishing before the construction. The condition survey includes this study where it has been mentioned as a fault as shown in Figure 3.22 [60].



Figure 3.22. Polished aggregates [60].

3.6.8.4. Shrinkage Cracking in Rigid Pavements

They are hairline cracks where their lengths are less than 2m and they do not cross the whole slab. These cracks are caused by the curing process and settings of the concrete slab. As well as they are caused because of higher water evaporation due to higher temperature cracks. Incorrect curing may also generate shrinkage cracks in rigid pavements. Figure 2.23 shows the shrinkage cracking in rigid pavements [60].



Figure 3.23. Shrinkage cracking in pavements [60].

3.6.8.5. Pumping Effects

Pumping is the process of expelling the water under the pavement layer. It is caused because of the loads of active vehicles that come over pavement repetitively. This will lead to fine materials exist in the subbase along with the water and get expelled with water. The pumping effect on rigid pavement is shown in Figure 3.24[60].



Figure 3.24. Pumping effect [60].

3.6.8.6. Corner Breaks in Rigid Pavements

These failures happen in rigid pavements because of pumping in excessive ratio. Corner cracks are generated when the pumping completely eliminate the underlying support which no or support presents below to take the load of vehicle. The maintenance approach is either by the replacement of full slab or maintain the full depth. A cross section of corner breaks is shown in Figure 3.25[60].

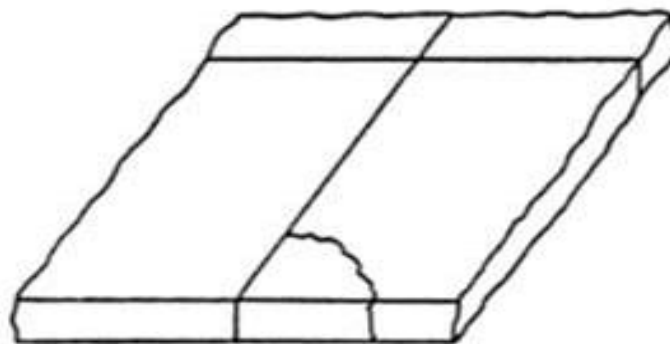

Figure 3.25. Corner breaks in rigid pavements [60].

3.6.8.7. Punch-out in Rigid Pavements

A local area of concrete slab which is broken to a piece is named as punch out distress. This type of distress may take any form or shape. They are usually defined by cracks and joints. The width of these cracks and joints are about 1.5 m. The punch out is mainly caused by many effects such as the heavy repeated loads, insufficiency of slab thickness, the base support loss or the construction shortage like honeycombing. Figure 3.26 shows a cross section of punch out distress [60].



Figure 3.26. Punch-out failures in rigid pavements [60].

3.6.8.8. Linear Cracking in Rigid Pavements

This type of distress divides the slab to two or three pieces. It is caused by traffic loads at repeated levels. The curling is because of the moisture and thermal gradient repetitively. A cross section of linear cracking is shown in Figure 3.27[60].



Figure 3.27. Linear cracking [60].

3.6.8.9. Durability Cracking in Rigid Pavements

The freezing and thawing actions will cause regular contraction and expansion that result in gradual breakdown of concrete. It is a pattern of cracks on the surface of concrete as parallel layers close to joints. The areas where the concrete appear to be more saturated are cracks and joints. Here, the dark deposit is seen and named the 'D' cracks. This failure in rigid pavement will lead at the end to complete disintegration of the entire slab as shown in Figure 3.28[60].



Figure 3.28. Durability cracking or 'D' cracks failure in rigid pavements [60].

3.9. Comparison of Rigid and Flexible Pavements

Flexible road surface differs from the rigid road surface in terms of load distribution. The distribution of flexible load relies mainly on the layered system. However, the same tile carries out the most load on the solid road surface and delivers light load of the main layer as clarified in Figure 3.29.

The properties of each layer are depended the flexible platform's structural abilities. The practical capacity of the steel pavement relies only on the concrete pavement characteristics. This is due to the low transport capacity of the mainland. Since the diversion basin depends on the substrate, it is very deep. In case of a rigid pavement, the deviation basin relies on the impartiality of rigid layers in the base layer. Flexible pavements have very low elasticity. The flexible factor of steel pavement is very high because of the high load capability of the high-strength concrete and the pavement itself. The sub-layer on the flexible road surface plays a very significant role [61].

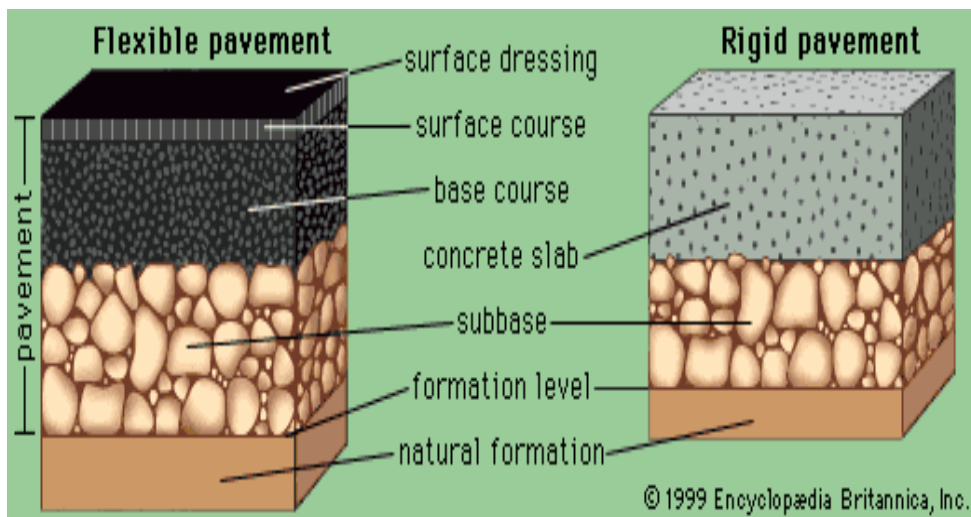

Figure 3.29. Rigid and flexible pavements [61].

The best roles are played by the upper layer for instance Tablet PC. So, the small part is made by the sub layer. The load is decreased when the depth of rising on the flexible road surface increases. In the rigid road surface, greatest load capability is performed by the plate of concrete itself to the lower surface. Therefore, generally,

both pavement types have advantages and disadvantages but generally and when discussing the standard conditions, the rigid pavements are used. On the highways, the rigid pavements are more used and selected as compared with flexible pavements. Nevertheless, in case of everyday and easy pavements on popular constructions, flexible pavements are promoted because they have low manufacturing costs. Figure 3.30 explains the distribution of loads on both rigid and flexible pavements [62].

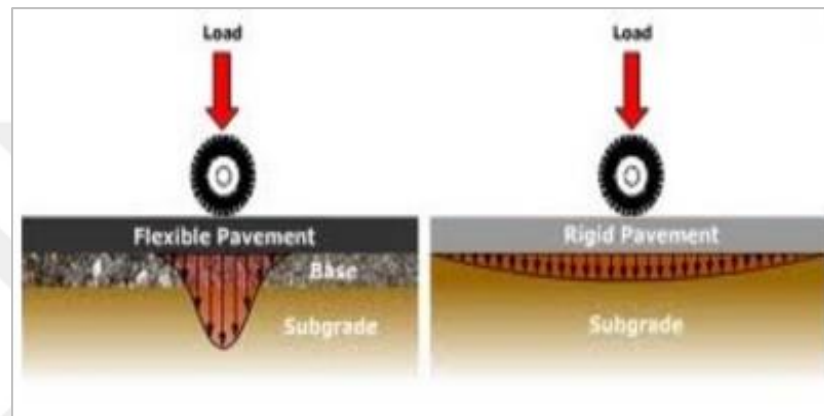

Figure 3.30. Rigid and flexible pavement load distribution [62].

Thousands of kilometers of asphalt concrete or cement concrete paved road applications are produced all over the world every year. Below, the amendment of the two kinds of coating is discussed from different angles.

Flexible superstructures can be opened to traffic after a very short time after being laid and compacted. On the other hand, rigid superstructures must wait at least 7 days before they can be opened to traffic, and the concrete's transportation time to a certain resistance must pass. However, this period, which takes the time for the rigid superstructure to be set, is eliminated with the additives accelerating the setting and hardening, which is added to the concrete during the construction, and the time of opening the concrete road to traffic can be reduced. Rigid superstructures are the only coating type that can accept iron reinforcement, but when necessary, iron reinforcement is used in the joints near the top surface of the plate against cracking. This is undoubtedly a factor that increases the cost. The fact that iron reinforcement

can be used together should be considered as an advantage that further increases concrete road life [72].

Slip friction coefficients of rigid superstructures are high compared to flexible superstructures and their sliding resistance is high. While the longitudinal friction coefficient is 0.70 in rigid pavements; the transverse friction coefficient is around 0.65. In addition, if a superstructure covered with cement concrete is wet, the coefficient of friction is less than that of other plastic binders. Since the road surface is flat, rainwater flows more easily than flexible superstructures and the surface is kept dry [73].

All kinds of maintenance-repair-renewal works on the roads made with flexible superstructure can be carried out easily, even during the continuation of the traffic flow. Indeed, flexible superstructure is a material that patches very easily. On roads constructed with rigid superstructures, there will be a delay due to this repair, which requires operations such as breaking the plaque and pouring a new plaque in place of it, having iron reinforcement inside the concrete, which also necessitates cutting and building, and waiting for a certain period of time to pour the newly concrete. This reveals a weak aspect of the concrete road against concrete asphalt pavements. However, concrete roads are a much more durable coating type than asphalt roads and require very little maintenance and repair. Therefore, considering the long service life, it reveals the fact that concrete pavements are more advantageous than asphalt pavements [73].

Preparation, pouring and compressing of concrete asphalt pavements should be done at a certain temperature. In this temperature decrease, asphalt concrete loses its softness and consequently leads to the formation of a coating below the desired level [73].

The structure of the asphalt used in the flexible superstructure mixture deteriorates by a certain period of time after the coating construction is completed, due to the volatility of the volatile substances in the structure of the asphalt and its oxidation.

This phenomenon is called aging of asphalt. Aging can be seen as embrittlement of bitumen, less elastic behavior, decreased binder characteristic against aggregate.

The binder of the superstructures is cement and it does not contain any volatile substances and it is impossible to talk about aging in rigid superstructures [74]. Rigid coatings are designed with a target of 2 times the service life of flexible coatings even at the design stage. The average life of rigid coatings is 34 years, while flexible coatings are 17 years [75].

Rigid coatings meet bending loads more easily. In tests performed by AASHTO, 61% of flexible coatings deteriorated in case of bending, while only 5% of rigid coatings deteriorated. When the loads on the coating are heavily weighted, the coating resistance is very effective in flexible coatings, while the heavier loads are not as effective as in flexible coatings [76]. This means that rigid coatings are more durable and less deformed against unexpected traffic loads.

In addition, it has been observed that environmental pollution occurs due to the presence of heating and drying processes in both the construction and application phases of flexible coatings. At any stage in the construction and application of rigid superstructures, there is no problem with environmental pollution [5]. It is possible to increase these and similar comparisons, and the advantages / disadvantages of flexible and rigid pavements below are summarized in Table 3.1 below.

Table 3.1. Rigid-Flexible superstructure comparison [5].

	Parameter	Flexible	Rigid
1.	Fast opening to traffic	++	-
2.	To be able to use iron reinforcement	-	+
3.	Frequency of repair	-	++
4.	Durability	+	++
5.	Sliding friction coefficient in wet state	-	+
6.	Weak basement floor	--	+
7.	Problems caused by heat loss during construction	--	+
8.	Quality aggregate requirement	-	+
9.	The obligation to make joints	+	-
10.	Cruising comfort	++	+
11.	Vision at night cruise	-	++
12.	Aging and being affected by chemicals	--	+
13.	Effect on increasing environmental pollution during construction	-	+
14.	Affected by low energy	-	+
15.	Wetness of the floor	-	+
16.	Dependence on climate conditions	--	++
17.	High annual increase rate in traffic	-	++
18.	Low annual increase rate in traffic	+	-
19.	High heavy vehicle ratio in traffic	-	++
20.	Bodywork coating reinforcement	+	-
21.	Bodywork foundation + coating replacement	+	+
22.	High discount rate and limited investment sources	+	+
23.	The road sound is annoying and uncomfortable	-	+

(++) : Very advantageous, very convenient.

(+) : Advantageous, convenient.

(-) : It creates inconvenience, not suitable.

(--) : Very inconvenient, not suitable at all.

PART 4

PAVEMENT DESIGN CRITERIAS

4.1. TECHNICAL CRITERIA FOR SUPERSTRUCTURE TYPE SELECTION

4.1.1. Traffic Effects

Regardless of the type of road network (village road, provincial road, state road, motorway, etc.), the road is required to be safe and comfortable throughout its service life. A path with these features; planning, design, construction, maintenance, repair, improvement, renovation stages can be realized by applying the basic engineering criteria. In order to be able to talk about highway design, it is necessary to have knowledge about design objectives, design constraints and design elements [39]. In determining the type of superstructure;

- Traffic composition (distribution by vehicle weight, upward trend, expected future traffic volume etc.) in light of the traffic volume on that road and annual average daily traffic values.
- Roadway axle load or wheel load.
- Number of axles or wheel configuration (geometry).
- Amount of tire pressure and contact areas.
- Knowing the information such as standard load repetition number will help to make a healthier decision in choosing the type of bodywork.

When designing the superstructure, it is especially important to take into account the road axle load and the number of repetitions of these axle loads, especially in order to prevent deformations that will occur in flexible superstructures, so the effects of axle loads on the deformation of the vehicles traveling on the highways are determined by the correlations.

4.1.2. Climate and Environmental Impacts

Asphalt concrete, which is a viscoelastic material due to its temperature sensitive structure in regions where seasonal and nighttime temperature differences are high, should be formulated and produced in such a way against formation of vestiges and vomiting at high temperatures in summer and cracking at low temperatures in winter, it is evaluated that the rigid superstructure will be less affected by both seasonal and daytime temperature differences and its usage is encouraged. In rainy season, rain and snow waters should be drained from the superstructure with the help of drainage systems in both types of coating. If there are soils such as silt and clay on the floor, when such water enters their bodies, they show a considerable volume difference. The blistering that occurs as a result of the change in this volume may cause breakage and dispersion in the superstructure. Surface waters formed with precipitation may cause erosion of all elements of the superstructure (road surface, banquette, splitting and filling slopes) [40]. Figure 4.1 shows the deformations in a flexible superstructure due to environmental factors.



Figure 4.1. Deformation due to environmental factors [42].

4.1.3. Material

Bitumen, which is a flexible superstructure binder material, differs from superstructures differing in terms of binder material, exhibits thermoplastic-viscoelastic properties under temperature changes. Asphalt used in the flexible superstructure mixture is degraded by the oxidation of the volatile substances in the structure and the asphalt ages. Aging can be seen as brittleness of bitumen, less elastic behavior, decrease of binding properties against aggregate and various deformations. The binder of rigid superstructures is the cement formed as a result of raw materials such as limestone, clay, marl loaded into carriers in the quarry zone and broken into single pieces with single jaw crushers and turned into raw meal (lime and silica) and heated to a high degree and therefore does not contain any volatile material and therefore the aging of cement concrete coatings. [43].

4.1.4. Ease of Construction and Maintenance

Flexible and rigid pavements have different features in terms of construction-maintenance-renovation properties. For example, in flexible pavements, it is possible to open the road to traffic as a result of the time it takes to dry the bituminous pavement without the need for a service road (up to a few hours). In terms of a rigid pavement, it is more troublesome to be opened to traffic [45].

The reason why a superstructure is preferred should not only be due to its rapid traffic ability. At the same time, the maintenance-repair recurrence interval of the superstructure should be investigated. A flexible pavement varies according to the types, but is designed for a period of 20 years (village roads need serious maintenance repairs almost every year rather than 10-20 years) and apart from the repair of local disturbances at the end of every winter season, after the first 5 years, minor repairs and surface coating are required. In the 10th year, the road surface will probably need to be renewed and roughened. After 20 years, (in turkey, the roads should not be complied with the design principles and flexible pavement, due to the fact that the design life is short, even if meticulously done), the structure should be reinforced with a new superstructure [41].

Rigid superstructures are designed for service periods of 30 - 40 years. The difference between 20 and 40 years of design is a 25 mm thick concrete layer. In the event that the design and construction works are carried out meticulously, concrete roads require very little maintenance and repair during their entire service life. Periodic maintenance is the process of renewing the joint fillings only every 4-5 years, which is a low-cost procedure that can be performed without interfering with the traffic.

Although not very common with such maintenance and repair items, when the fine-grained floors become saturated with water, concrete is injected under the collapsed slabs at the end of the pumping event caused by the water mixture coming out of the joints or close to the joints and cracks due to the continuous collapse of the edges of the covering plate, failure of fresh concrete and small maintenance and repair items such as covering cracks with cement or synthetic resin mortar may occur [44].

4.2. ECONOMIC CRITERIA IN SUPERSTRUCTURE TYPE SELECTION

The most important criterion to be considered when choosing a superstructure is undoubtedly the total economic cost calculated for the project life. It is possible to gather economic analyzes of highways, the feasibility of which is carried out by the (GDH), under three main headings. The first of these is the costs incurred from the necessary expenditures during the period from the beginning of the project to the end of its economic life, the second is the discount rate, which is a parameter that enables the determination of the past or future values of a monetary value in the time line [43]. In general terms, the real economic cost of any superstructure;

- Construction cost,
- The maintenance exposed throughout its service life - operating cost and
- It is calculated as the sum of the delay costs in terms of use due to the maintenance it is exposed to [5].

4.2.1. First Construction Cost

When calculating the initial construction cost of a superstructure, some determinations should be made below. These;

- Determination of the costs of the materials to be used in the type, quantity and resource,
- Transportation cost of the materials,
- Labor expenses,
- Costs related to construction machines and
- Consists of items such as maintenance costs [5].

4.2.2. Operating Cost for the maintenance during Project Life

While choosing the superstructure regardless of the road network (village road, provincial road, state road, highway, etc.), firstly technical and economic comparisons should be made, and Finite Element Model (FMA) (benefit cost analysis) should be decided by taking into account the reserves located within the borders of the country. Although rigid superstructures seem to be more costly than flexible superstructures and derivatives in terms of initial construction costs, when this benefit is analyzed in the light of cost analysis, the rigid superstructure which is much longer lasting becomes more economical. Choosing a bodywork according to the lowest initial construction cost does not mean that it is the most economical solution. Because maintenance-repair-operating costs need to be taken into consideration, and this was taken into account in our study.

Concrete roads, which are meticulously applied according to their standards and designed for 30-40 years of service periods, do not require surface renewal and reinforcement processes and the only process that requires periodic attention is the process of renewing a joint filling place in every 4 or 5 years repetition times. Briefly, concrete coatings are more sensitive to difficult and expensive repairs than flexible superstructures.

4.3. Thickness Determination According to AASHTO 1993 Design Method

In the calculation method of rigid structures, AASHTO (1993) Design Method is used considering the rigid plate behavior that sits on the elastic ground. Since the design of RCC roads is not included in the design method of AASHTO (1993), RCC, joint less non-reinforced concrete coating (JPCP, Jointed plain concrete) in the empirical method of “AASHTO Test Path Equation”, assuming that the rigid superstructure type closest to RCC roads is designated without joints. Pavements and RCC thickness were determined with this approach. Parameters in the formula;

$$\log(W_{18}) = (Z_R \cdot S_0) + 7.35 \cdot \log(D + 1) - 0.06 + \frac{\log\left(\frac{\Delta PSI}{4.5 - 1.5}\right)}{1 + \frac{1.624 \cdot 10^7}{(D + 1)^{8.46}}} \quad (4.1)$$

$$+ (4.22 - 0.32 \cdot Pt) \cdot \log \left[\frac{S_c \cdot C_d \cdot (D^{0.75} - 1.132)}{215.63 \cdot J \cdot \left[D^{0.75} - \frac{18.42}{\left(\frac{E_c}{k}\right)^{0.25}} \right]} \right]$$

W18: Equivalent Axle Load Repeat Number (EDYTS)

d: Coating Thickness (inc)

Sc: Concrete Flexural Strength (psi)

Ec: Elasticity Module of Concrete (psi)

k: Ground Reaction Module (lb / inc³) R: Reliability (%)

ZR: Normal Standard Deviation

SO: Total Standard Deviation

O PSI: Loss of Service Ability

PI: First Service Ability

PT: Last Service Ability

Cd: Drainage Coefficient

J: Load Transfer Coefficient

When following process algorithm is followed for design;

- Last service ability index (PT) is selected,
- Traffic analysis time (T) is selected,
- Project traffic is calculated,
- Tensile safety stress (Sc) is selected for bending of concrete,
- The reaction module (k) of the base floor is determined,
- Concrete slab thickness is determined according to PT, T, Sc, k, and project traffic values.

Total Standard Axle 8,2T Repetition Number

Total Standard Axle 8,2T Repetition Number is chosen with the vehicle equivalence factor (VEF) in Table 4.1 by determining the number of vehicles that will pass the forecast from the bodywork platform and the amount of increase in percent on an annual basis. In addition, in order to reach the total number of standard axle 8,2T repetitions, “the average number of daily standard axle load repetitions falling on the account lane” is required, and the calculating lane factor (η):

1.0 has been taken from the "RCC Roads Design Guide" and the vehicle traffic in both directions will be equal for 2 lanes, and the values found are shown in the table below.

Table 4. 1. Vehicle equivalence factors [30].

Vehicle Group	Vehicle Equivalence Factor [VEF]
Trailer	4.10
Truck	2.90
Bus	3.20
Medium Loaded Commercial Vehicle	0.06
Car	0.0006

Load transfer coefficient: It can be determined from Table 4.2, taken from AASHTO 1993 and AASHTO has no load transfer coefficient related to RCC, and is

considered to be the nearest rigid superstructure, and is considered to be a non-reinforced rigid coating, and its value is chosen as 3.2

Table 4.2. Recommended load transfer coefficients for various coating types [30].

Load Transfer Coefficient (J)		
Are reinforced concrete roads or anchors available?	Are there concrete pavements, barriers, gutters or multiple lanes in one direction connected by reinforcement?	
	YES	NO
YES	2,90	3,20
NO	3,70	4,20

The data used in the design; In the light of “Rolled Compacted Concrete Roads Guide, Rolled Compacted Concrete Roads Technical Specification” documents prepared by Turkey Petroleum Refineries Corporation (TPRC) in 2018, the determined data are given in Figure 4.2 and in Table 4.3 . Effective Ground Reaction Module (k, lb / Inc³, psi) detection [30].

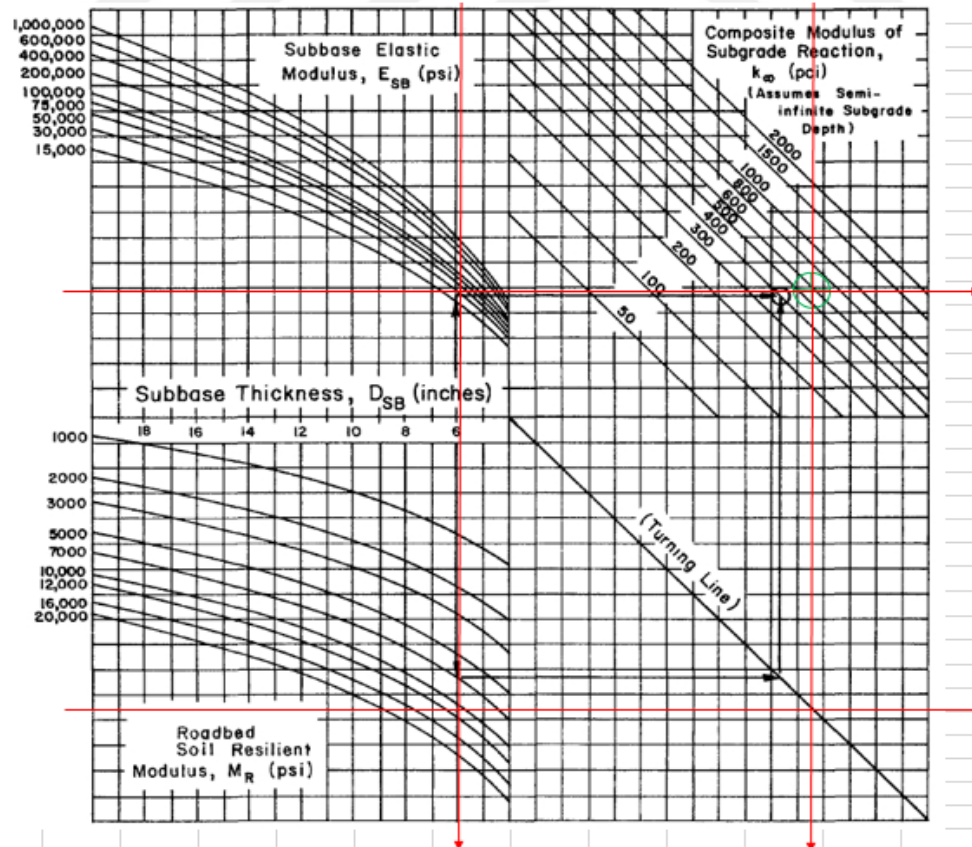

Figure 4.2. Data used in the design [30].

Table 4.4. Data used in design [6].

Parameter	Value Received
Superstructure Project Duration (years)	20
EDYTS	4336665
Reliability (R%)	75
Normal Standard Deviation (ZR)	0.674-
Total Standard Deviation (S0)	0.35
First Service Ability (pI)	4.2
Last Service Ability (PT)	2.0
Loss of Service Ability (PT-pI)	2.2
Drainage Coefficient (Cd)	0.9
Load Transfer Coefficient (J)	3.2
28-Day Concrete Flexural Strength (Mpa-psi)	4.20 mpa Psi609
Concrete Elasticity Module (EC, Mpa-psi)	32000 mpa Psi4,640,000
Effective Ground Reaction Module (k, lb / Inc ³ , psi)	560
Substrate Thickness	15 cm
RCCTHICKNESS	16,5 cm

PART 5

HYBRID PAVEMENTS

This type of pavements consists of concrete track and asphalt track and each one of them adjacent to each other. Each of them has its own design in addition to operative properties according to international and Turkish standards. The hybrid pavement has concrete pavement and asphalt paving between them expansion joint.

5.1. PROBLEM STATEMENT

The deformations exist in flexible pavement are caused by many factors including the overloading, lack of high-quality asphalt or by weather factors. These deformations are always seen on highways or signals locations. Therefore, we saw that it is possible to design a hybrid pavement in order to mitigate these deformations which may affect negatively on road comfort and safety. Thus, the goal is to prevent the deformations of asphalt concrete pavement especially bleeding and rutting on highways on the right line because of heavy vehicles particularly undulation on the roundabouts (junctions) because of brake and rolling resistance through the application of cement concrete pavement on the one line that can be (right line) or junctions and asphalt concrete on other lanes together that is named "hybrid pavement.

5.2. HYBRID PAVEMENT

Generally, the asphalt concrete is considered composite material and used for road paving and parking. Since the twentieth century, asphalt mixes used in paving constructions. It involves asphalt mineral combinations which are compressed and folded. Hybrid pavement or bituminous asphalt concrete and bituminous mixtures are typically only used in construction and engineering. They can be defined as any

composite materials comprising mineral glue with concrete glue. Occasionally, AC Shrinkage is used in asphalt concrete but may include bituminous cement or bitumen that is an integral part of composite liquid bitumen. Figure 5.1 and Figure 5.2 explain the problems that happen in flexible asphalt of abnormalities including rutting that occur in the road at stop light in Karabuk city in Turkey. The traffic will continue in increase and heavy vehicles that use the roads lead at the end to the road deterioration. In some regions including short-term vehicles or delays, road signs, heavy brakes and crossings cut the way.



Figure 5.1. Asphalt rutting and deformations in Karabük – Turkey.



Figure 5.2. The rutting and deformation of asphalt in Karabük - Turkey.

Deformation in traffic happens because of increasing the pressure when the vehicle or car move in a circular motion particularly when driving on road and when the vehicle weight is simple. Furthermore, the gravity and direction of tires will change too. Figure 5.3 and Figure 5.4 clarifies the problems which happen when distribute the load on both wheels [15].

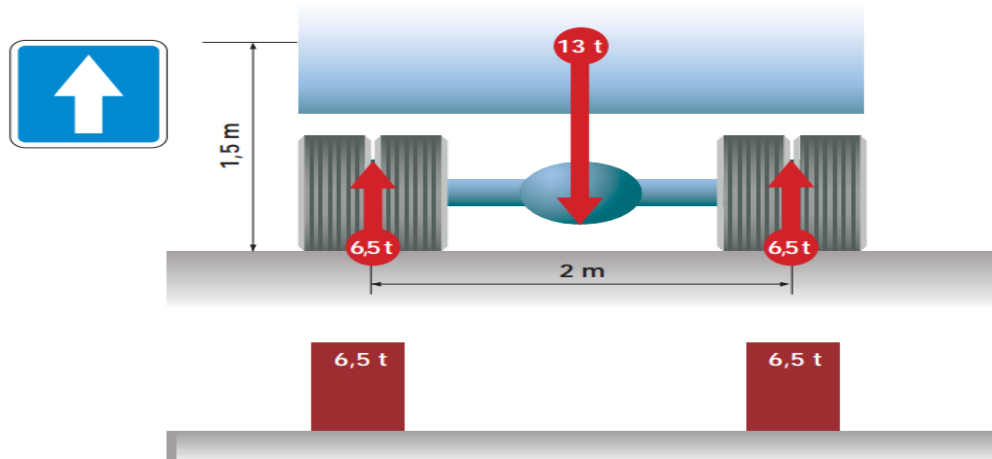

Figure 5.3. During turns, partial transfer of the load to the outer wheel [15].

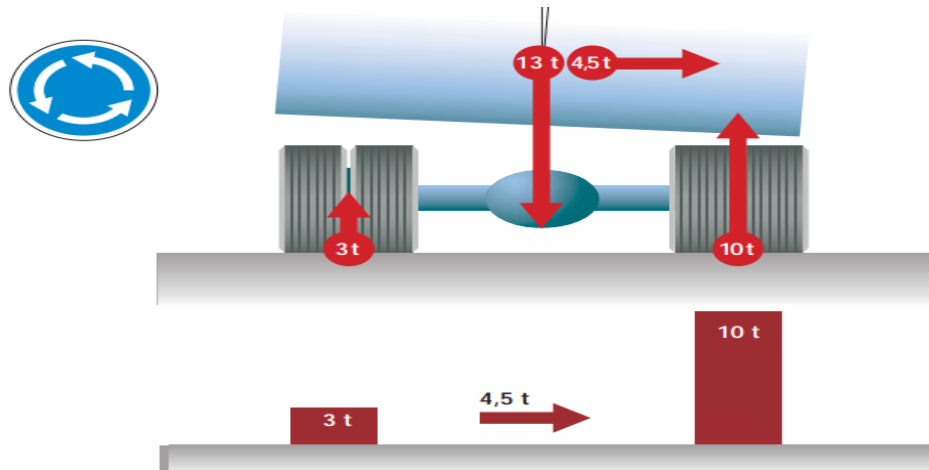

Figure 5.4. In straight alignment: even distribution of the load on both wheels [15].

For example, donating the significance of asphalt problems particularly in junctions survey (15) , discovered that researches included approximately all types of transportation means. The vehicle movement and its effect on welding, tearing and deterioration of asphalt concrete rotor conditions got worse. The importance of disrepair explained in this study is clear and this depends on the importance of traffic and sometimes the structural size of road too. Therefore, it is significant to collect between all ideas along the way in order to get rid of such problems. Problems happen in traffic roundabout are shown in Figure 5.5 [15].



Figure 5.5. Shows the problems that occur in the traffic roundabout [15].

It takes this name because of this issue that means rigid pavement and flexible pavement separated by extension joints. For clarity purpose, it is necessary to clarify the significance of this asphalt in the maintenance of this road correctly and safely and explain the difficulties that may face the determination of this idea problems which explained in Figure 5.6.



Figure 5.6. The idea of flexible and rigid pavement in the single road line.

5.3. THE IMPORTANCE OF HYBRID PAVEMENT

The significance of hybrid pavement lies that the resulted load from heavily loaded vehicles in pavement may cause damages on the road and therefore cause the collapse of roads. The collapsed roads may lead to road loss which may violates safety and repetition cost for each year, loss time because of repair and maintenance and public resources wastes. The different elements which effect on road activities are explained below:

- The heavy traffic every day. So, it results in increasing the contact weight, loads of wheels and axle configuration. Therefore, increasing the load movement that effect directly on pavements.
- The structural model of road has direct effect of roads.

- The physical characteristics of road pavements effect the activities and therefore the structure of road entirely.
- Many environmental factors including moisture and temperature effect negatively on the structure of roads.

5.4. WHY CHOOSE CEMENT INSTEAD OF ASPHALT

The use of concrete seemed essentially suitable to meet any requirements and demonstrated its rigidity and stress tolerance when used on roads, airports, tunnels and constructions. It is known that concrete is easy to handle and form. It does not need advanced application equipment and cannot be ignored due to the natural orientation and mechanical properties and reducing the limit of work efficiently. We know very well that Turkey is one of the first countries in the cement industry, but it was not used well, and hybrid pavement is one of the solutions that we can take advantage of and this idea can be explained in a way Concise and helpful. Where the hybrid road surface consists of two roads, one concrete and the other asphalt according to international standards due to the high quality of the hybrid used in paving .The specifications of pavement must be mixed and Figure 5.7 explains the difference between the use of concrete and bituminous.

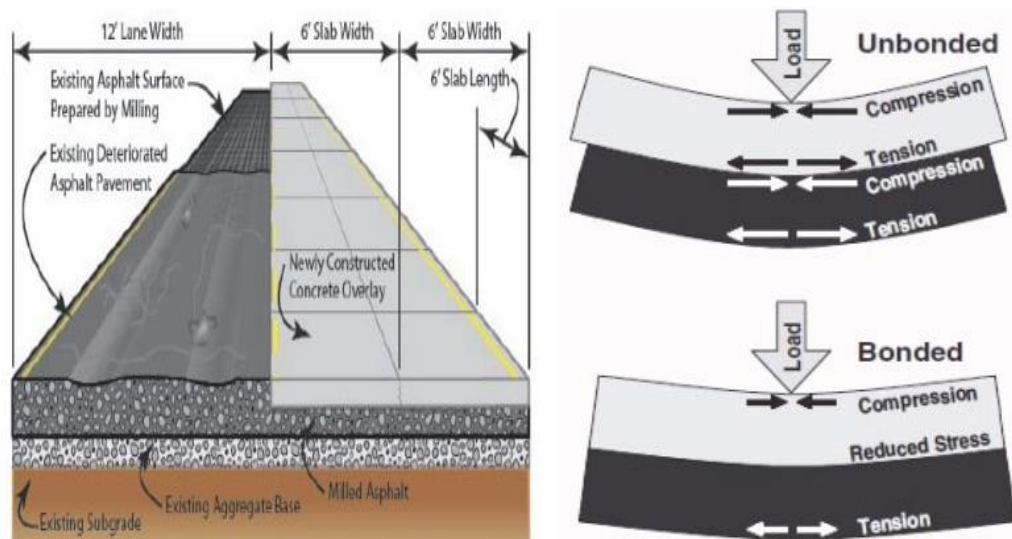

Figure 5.7. Shows the difference between the use of bitumen or concrete [63].

5.5. USING THE RIGID PAVEMENT IN TURKEY

The length of the road in Turkey is 67.333 km in 2019 and it is under the responsibility of the GDH. It is created in March 1, 1950 and only small section of this road has been designed as a rigid superstructure. In Turkey, GDH is responsible on the applications of rigid superstructure for many years as shown in Table 5.1 [4].

Table 5.1. Rigid superstructure applications in Turkey [4].

Place	Afyonkarahisar Emirdağ	Hasdal Kemberburgaz	Ordu Ulubey	Karamürsel
Length	2 km	3.5 km	1km	1.6 km
Number of Lanes	3	2	2x2	2x2
Year of construction	2004	2006	2007	2010

Since our roads that are worn in short time because of the traffic density and natural circumstances, the approximate cost for maintenance and repair of roads is about 2 billion Turkish lira every year and it is under the responsibility of GDH [4]. Thus, in Turkey, instead of GDH, particularly local authorities' concrete roads, long years of repair and maintenance, and seasonal circumstances are influenced by similar reasons as the minimum level. In a study made in 2004 , the local administration including Denizli Metropolitan Municipality, Samsun Metropolitan Municipality, Antalya Metropolitan Municipality and Kocaeli Metropolitan Municipality included models of rigid structure in their investment programs and noticed the manufacturing of concrete roads in countryside roads and roads between villages [4].

Rigid paving includes steel beams, fibrous joints, concrete and steel bars as shown in Figure 5.8. The section involves a concrete layer and an asphalt course with thickness of rigid is 0.3 m and flexible is 0.10 cm for the surface and 0.20 cm for the base course. under that layer, a granular course layer with thickness of 0.250 m. Depending on the statement that no deformation exceed a specific depth in the

subgrade, the subgrade depth was stable at 0.450 m. based on the studies in the literature , AASHTO and GDH .

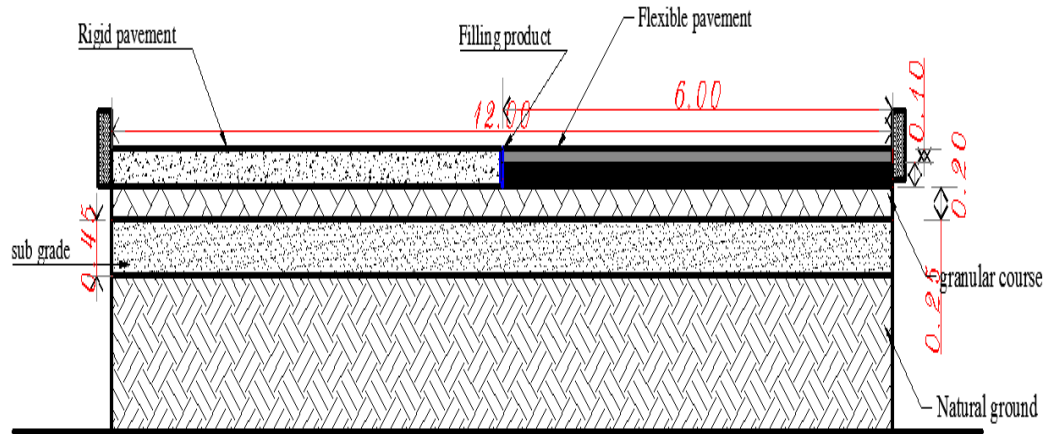

Figure 5.9. Design of hybrid road.

The drainages for this type of separator aims to lateral drainage without damaging the road or subcutaneous in spite of the existing of some studies in scientific research and it may be used in French is shown in Figure 5.9 that delivers answers research for dizziness.



Figure 5.10. Shows the use of rigid paving in the traffic roundabout in French [15].

In addition to what we have mentioned before, the benefits of using hybrid pavement can be summarized below:

- Hybrid pavement plates have great power.
- The cost of maintenance for hybrid pavements are lows in spite of high transportation costs.
- They have fair ecological actions.
- Hybrid pavement plates allow vehicles on using less amount of oils.
- The surface of road has efficient flexural power to move the weight of load on wheel on wider region below.
- Since the load of tire, the tire curve allows the temperature change and thus, decrease the pressure and tension.
- Hybrid pavement plates are appropriate for predator resistance and high pressure.

The difficult way locks stronger in the light color of rigid plates but it is possible to add color according to requirements as shown in Figure 5.10.



Figure 5.10. Rigid paving [64].

Turkey has experience for the RCC and has begun to be used in various cities of Turkey. the RCC performs much better than flexible pavements in terms of both durability and long life. In addition, application examples of RCC, which are easier to use in the construction stages such as laying and compacting the road in terms of

using flexible pavement construction techniques, appeared before during the construction of dams and are now preferred by local administrations in provinces such as Samsun, Kocaeli, Denizli and Tekirdağ, Antalya. [79].

Even in the superstructure has begun to be used in Table 5.2 in various cities of Turkey examples of RCC applications are presented.

Table 5.2. RCC road applications made in various regions of Turkey [80].

Application Year	Application Type	City	Concrete Road Application
2009	Steel Fiber RCC	Antalya	150 m
2011	Steel Fiber RCC	Denizli	500.000 m ²
2014	RCC	Samsun	190 km
2014	RCC	Kocaeli	2.5 km
2016	RCC	Tekirdağ	34 km

5.6. COLLECTIVE INFLEXIBLE DISTRESSES OF PAVEMENT

The collective inflexible distress of pavement can be summarized as follows [65]:

- **Spalling:** it is a result of brick natural stones and concrete incoming to waters. Spalling enforced the surface to be removed. This type of distress is popular and it is also called firing inside limestone. Therefore, peeling may cause structural damages.
- **Faulting:** It is the crack drains the rock. Its length is ranging from microns to thousands of kilometers long and its deep is ten kilometers deep. In addition to changes in orientation and measurements, many shortcomings may offset different deformities of rock including elongation and compression.
- **Cracking:** It is a series of great rectangular cracks in the pavement. This type of cracks usually covers large area and it may appear where no transportation is existed.
- **Longitudinal cracks:** They are configured parallel with the center of pavement. It is possible to create longitudinal cracks in the pavement of

concrete and asphalt. They present the existing of main cracks and possible structural impacts.

- **Slab cracking:** It is caused because of gradient in humidity and temperature in the upper and lower part of the concrete result in bending and tension of the slab. The concrete is cracked commonly because of the natural reaction.
- **Durability “D” cracking:** they are the cracks on the form of crescent in the vicinity of cracks, cracks or corners. This is because of complete freezing onboard the PCC. Precluding the cracks is a popular PCC experiment that is not single to the PCC.
- **Polished Aggregates** result in HMA paving region where the aggregates which spread through the pavement of asphalt are so small or have not singular sections or rough.
- **Possible cause:** application of duplicate traffic. In general, as the surface of road wears out, the practiced elements gloss.
- **Pop-outs in Jump windows** generally occur because of weak durability of polymer. Poor melting resistance, freezing and poor durability may be the result of numerous projects.
- **Blow Ups in the road surface explosion** appears when the surface of roads spreads to a wreck or crack where the moisture is penetrated. The surface of road is weakened by such cracks and heat causes the surface to bend and rot.
- **Pumping and water bleeding** is also a result where it is configured when the fine materials and water are injected under moving load by a crack in the HMA layer.
- **Shrinkage cracking** starts when it hardens. The present humidity and temperature gradient at top and bottom of the concrete cover resulting in bending and tension of slab.
- **Breaking the separation between asphalt and concrete:** it is possible that a part of the separation between asphalt and concrete broken because of the motor vehicles movement above it. It may cause weakness in this point.

All of these are the main results of distress in the pavements. Since the noise of tires create kinetic energy of sound waves, there is more noise because the speed of vehicle increase. At the beginning of seventies of the last century, shell design concept

is emerged that may take acoustic engineering considerations in consideration such as the selection of surface paving covers. The main benefit to use steel plates is the durability and ability to shape. All of these are main results of distress in pavement as shown in Figure 5.11.

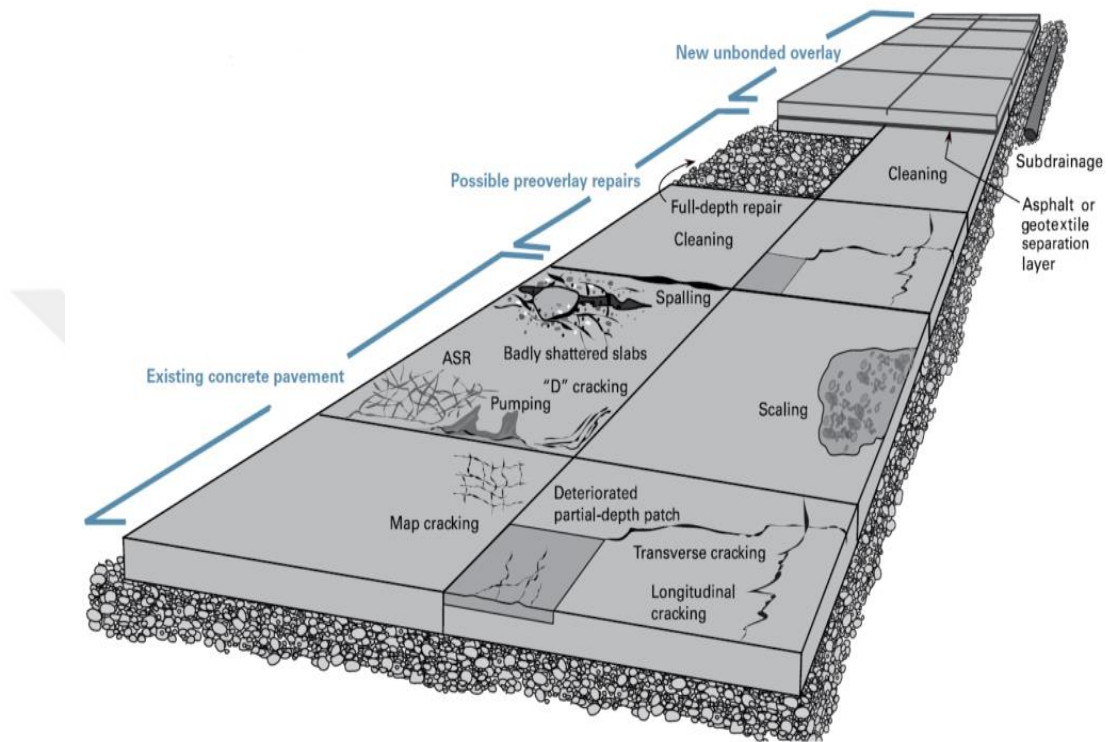

Figure 5.11. Shows us of rigid paving deformations [65].

5.7. THE FOLLOWING EXPERIMENTS

There are several different types of wheel-tracking devices; the most prominent devices will be covered in this research and it is preferable to used and accept the result of the software that well used in this research.

We may use some of the equipment in order to test the effect of load on pavement to observe the deformation on pavement. N-vitro devices are used in simulation tests which through we can measure HMA properties by rotating the small wheel frequently by the prepared HMA model. Later, the test sample performance is associated to the actual performance of pavement though the service. Laboratory wheel tracking devices may be used for moisture exposure, soaking, fatigue and

abstraction forecasts. Generally, they include on ghost and other measurements but the user must be careful to determine the laboratory conditions (including temperature, wheel passage and load) which create related and accurate correlations with the field performance .Hamburg Wheel Tracker is between them as shown in Figure 5.12 and the Laboratoire Central des Ponts et Chaussées) "LCPC" is also called French Rutting Test as shown in Figure 5.13.

The wheel tracker in Hamburg (HWTD) has been developed in Germany and can be used to evaluate the abstraction and erosion potential. HWTD tracks is a steel wheel loaded forth and back straight on the sample of HMA. In general, tests are performed on 10.2 x 12.6 x 1.6 inches (260 x 320 x 40 mm) ,wheel can be tracked during the submerged sample (underwater) for 20,000 cycles (or even 20 mm of deformation) by the use of a 158-pound (705 N) load. Depth of root is measured continuously with a LVDTs series on a sample. Several modified HWTDs have been created in the United States with main modifications which are type of wheel and loading power. (LCPC) wheel tracking tool, also called French Stippling Test (FRT) was used in France for more than fifteen years to asses HMA leveling properties [70] .(Pavement Interactive). FRT tracks a compacted antenna frame back and forth across the sample of HMA. Generally, the test is conducted on 7.1 x 19.7 x 0.8-3.9 inch plates (180 x 50 x 20-100 mm) compacted with a plate compactor. Most frequently, the wheel is traced by a sample of 30,000 cycles by the use of a load of 1,124 lb (500 Nm) applied to a compressed antenna wheel of up to 87 lb (600 kPa) [70]. Thus, Hamburg Wheel Tracking Device and French Rutting Test can be used in proving the tolerance of suggested pavement for pressure factor and the effect of temperature on it. In this experiment, it is easy to notice the early failure of bitumen mixture because of weakness in design deficient binder rigidity, or moisture damage, and other elements such as deficient adhesion between the aggregate and binder of asphalt [70].



Figure 5.12. French rutting test [72].



Figure 5.13. Hamburg wheel tracking device [70].

5.8. THE FOLLOWING SOFTWARE CAN BE USED TO TEST THE IDEA OF WORK

There are several programs that can be used for paving analysis and knowledge of initial results that may be used in several other research related to flexible and rigid pavement both separately. And because the experiments will be costly and need time for that in the literary first step of these studies is to apply for simulation programs

and for this theses I chose Abaqus because in the literature in general this type of problem generally solved by Abaqus.

Abaqus is a suit program of engineering simulation that heavily depend on limited factor approach. It may solve problems ranging between relatively simple linear analyses to more nonlinear analyses simulations. Abaqus has a comprehensive list for models of materials which may simulate the behavior for most of the engineering materials including metals, composites, rubber, crushable and flexible foams, reinforced concrete, polymers and geotechnical materials including rock and soils. Abaqus has been designed a general-purpose simulation tool and it is used to study problems more than just structural (displacement/stress) [33]. This program simulates problems in many fields such as mass diffusion, soil mechanics. Heat transfer, thermal management of electrical element (coupled thermal-electrical analyses), fluid dynamics, audibility piezoelectric analysis and electromagnetic analysis [33]. Moreover, it provides a wide set of capabilities to simulate the linear and nonlinear applications. Problems of many elements are modeled by relating geometry that determine each compound with the models of suitable materials and assign the interactions of components.

In nonlinear analysis, the program spontaneously selects appropriate load increments and possibility of convergence and constantly modifies during the analysis to guarantee that the optimal solution has been gotten effectively [33].

It is possible to check the load of pavement and investigate the effect of repetitive loads on fixed wheels on road reaction and cavity formation [33].

5.9. THE JOINTS AND THEIR LAYOUT

The goal of association is to discover and correct the concrete cracks location specifically the nature and climate change. The circular rotor bridge has trapezoid and the preparation plan is considered the key process. The plan must consist the following rules. The biggest popular space is 25 times the slab thickness (Instance 3 m, 12 cm slab, 5 m slab, 25 cm); - the angle of the plate is 75 °.

In order to enhance the load transfer in the elbow joints from one plate to another, it is significant to take into account that the upper slope of the plate is parallel to the axis at the mean thickness of the plate 15° as shown in Figure 5.14 [15].



Figure 5.14. Shows the distances between concrete slabs as well as joints [68].

The needle position from any hypothetical position must not be ignored:

- 2 cm to the top surface of the table;
- 2 cm wide along the road axis.

These cylinders are 240 degree \geq Fe E smooth steel bars that are concealed at least half their length and do not fit to the concrete to permit the removal of long products, because of heat expansion and compaction. The board thickness determines the size and cavity. The basket support dowel joints are shown in Figure 5.15 [15].

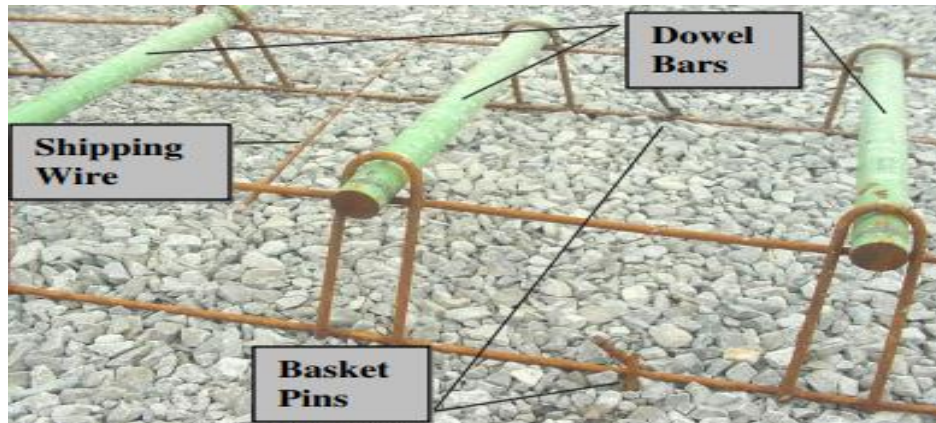

Figure 5.15. Shows the basket support dowel joints [69].

In general, these wedges are placed on blanket named as basket or concret pour point as shown in Figure 5.16.

The baskets are usually manufactured from $\phi 6\text{mm}$ steel and are committed to the base layer. Also, they should not form joints in the joints. Figure 5.17 and Figure 5.18 show the construction joint [15].

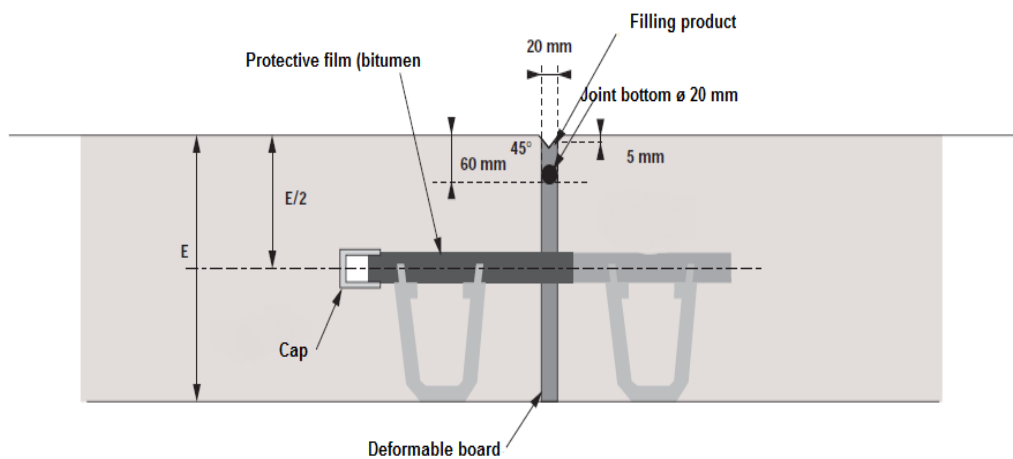

Figure 5.16. Shows basket support dowel [15].



Figure 5.17. Construction joint [70].

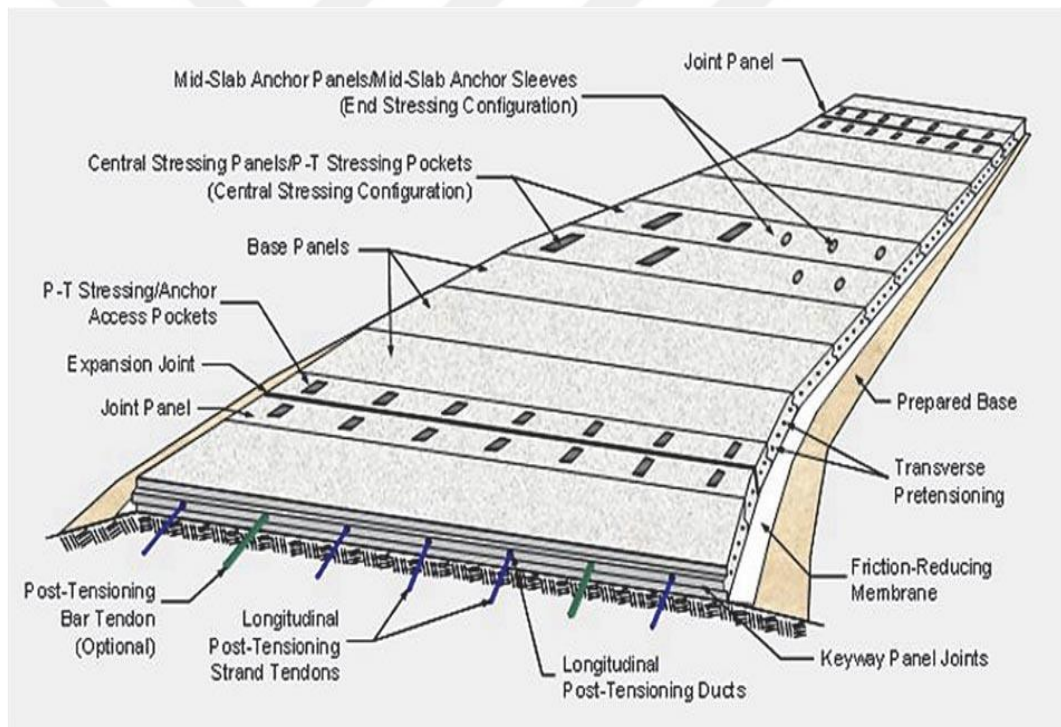

Figure 5.18. Construction joint [63].

The joint that between slabs of concrete can be modified while the wheel is presented in order to decrease the sounds as the wheels intersect or as clarified in Figure 5.19. The line of this type of pavement can be made at angles (45 °) or (60 °) that may help reduce sounds.



Figure 5.19. The joint between the concrete [63].

5.10. USING ABAQUS SOFTWARE ON HYBRID PAVEMENT

Through the last two decades, Finite Element (FE) techniques have been successfully used in order to different problems of pavements which cannot be designed by the use of multi-layer elastic theory. In our study, the two-dimensional limited elements model has been developed by using Abaqus software program to study the effect of static and dynamic load on pavement. Constructing model procedures and perform static analysis are presented. With this model, the paving materials are presented as linear-elastic– plastic depending on Drucker-Prager model for dynamic loading circumstances. Rutting is considered the main distress faced in asphalt pavement is main problem in the surface of road particularly during summer seasons as the temperature will be very high. It leads to permanent wear and the entire lateral changes lead to traffic reloading. Routine influence on resistant to permanent deformation with various depths of roadway for asphalt pavement. As known that the sidewalk is the reason of the big part. The final routine depth is measured on the path surface. This is the reason where circuit breakers only occur on the flexible roads. The belt depth or regular deformation is expressed followed by the tire. The structural properties and depth and width of the track are common in the folding layer (material quality and thickness), load, traffic and ambient circumstances [34]. The analysis of pavement structure is conducted by using Abaqus software package.

The model analysis results were standardized with the field dimensions for the pavement of an arterial rural road. The significance of this study came from the fact that many agencies and institutions have adopted rutting as a failure standard in design of pavement. The whole of these approaches almost assumes a relationship between the stress and strain and the following reply of the pavement structure. The important case is strain and stress in the vertical axis of load center. It is calculated in this point as clarified in Figure 5.20 and Figure 5.21 [34].

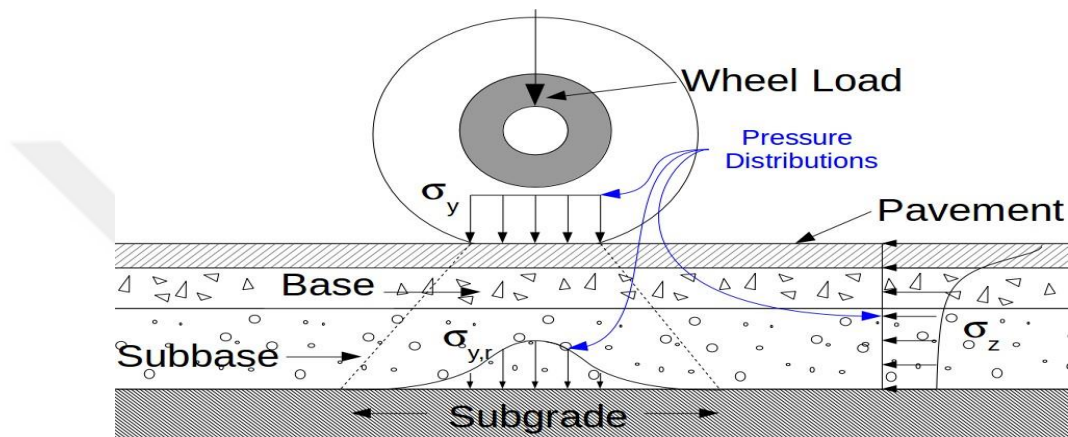

Figure 5. 20. Pavement design due to rutting criterion [71].

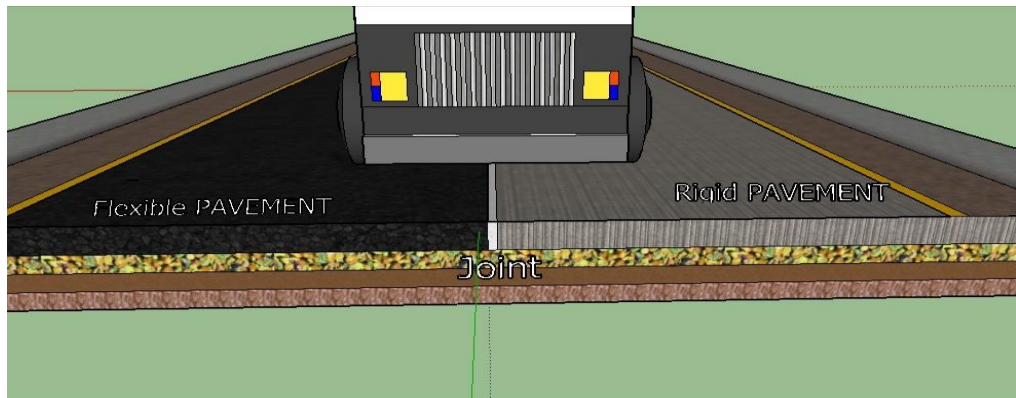

Figure 5. 21. General shape of the road.

The pavement section of studied highway has been simulated by the use of two-dimensional plane strain finite factor model. The model involves a concrete layer and an asphalt course with thickness of rigid is 0.3 m and flexible is 0.10 cm for the Surface and 0.20 cm for the base course. And a granular course layer with thickness of 0.250 m. Depending on the statement that no deformation exceeds a specific depth

in the subgrade, the subgrade depth was stable at 0.450 m. based on the studies in the literature, AASHTO and GDH

5.11. ANALYSIS MODEL

Materials and analysis model that used in each section are clarified below. The plane strain quadratic factors with full integration points have been assigned to the tires and pavement have been modeled as rigid parts. Fine mesh have been used around the places where high stresses arise. We attempted to create two cases;

The first case is the vehicle above the hard paving and flexible paving as clarified in Figure 5.22. The second case is the vehicle where one of its tires on the joint as clarified in Figure 5.23.

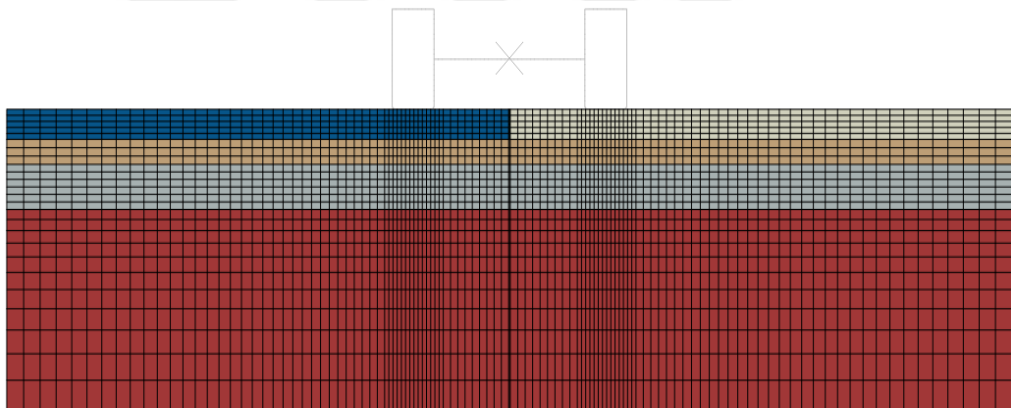

Figure 5.22. Case-1 the effect of load on the both of the pavement.

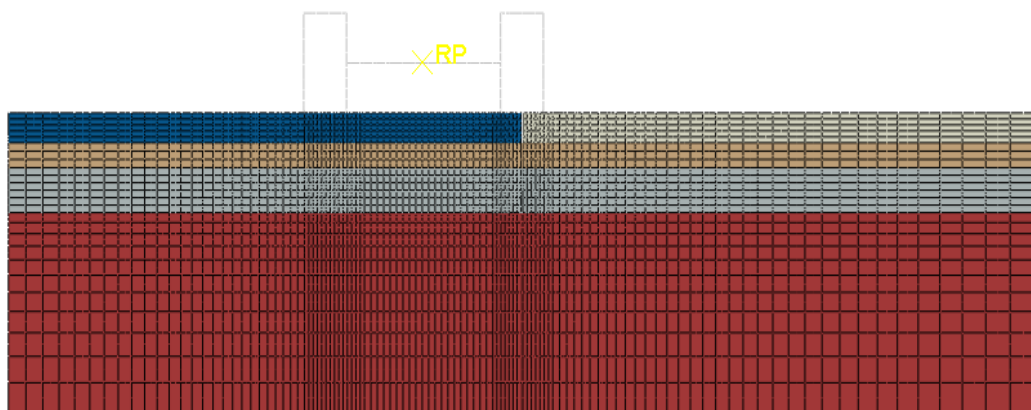

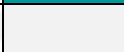





Figure 5.23. Case-2 the effect of load on the joint.

5.12. ELEMENT TYPES AND MESH SIZE

The 8-node, quadrilateral plane strain element from the Abaqus two-dimensional, solid-element library has been selected to be used in the analysis. The entire elements were 8-nodes biquadratic to enhance the accuracy level. [34]. Table 5.3 shows the Key of the layout.

Table 5.3. Key of the layout.

Materials	Edge	thickness	Withed	Color
Filing	•	0.3 m	0.03 m	
Flexible pavement	•	0.3 m	5 m	
N ground	•	More 2 m	10 m	
Rigid pavement	•	0.3 m	5 m	
Subgrade	•	0.450 m	10 m	
Granular course	•	0.250 m	10 m	

5.13. MATERIALS

Properties of linear elastic materials with Drucker-Prager plasticity model have been applied for all layers. Nevertheless, Mohr-Coulomb plasticity model has been adopted for N Ground section. Properties of materials were extracted from literature. Table 5.4, Table 5.5, Table 5.6 and Table 5.7 consist materials of rigid paving, flexible paving and the joint.

Table 5.4. Material properties of flexible pavement [34].

Layers	Density (N/m ³)	Poisson's ratio (%)	E-Modulus (Pa)
Asphalt	24000	0.4	1700E ⁶
Granular course	20000	0.35	120E ⁶
Subgrade	17000	0.35	50E ⁶

Table 5.5. Material properties of soil mechanical [35].

Density	1200 kg/m ³
Elastic modulus	100MPa
Poisson's ratio	0.3
Cohesion	0.11MPa
Internal friction angle	20°

Table 5.6. Material properties of concrete mechanical [35].

Density	2400 kg/m ³
Elastic modulus	2.5_10 ⁴ MPa
Poisson's ratio	0.15
Compressive elastic limit	18MPa
Compressive strength	25MPa
Internal friction angle	30°
Dilatancy angle	20°

Table 5.7. Material properties of Steel mechanical [35].

Density	7800 kg/m ³
Elastic modulus	2.1_10 ⁵ MPa
Poisson's ratio	0.3

5.14. JOINT SEALANTS AND MASTICS

Bitumen-rubber based, highly elastomeric, hot applied mastic for both horizontal and vertical uses. It obeys to ASTM D6690 AATHTO -m324 standard [83].

5.14.1. Features and Benefits

The features and benefits can be summarized as follows [83]:

- It protects the elasticity in very low and very high temperature such as between -20 °C and +80 °C.
- It is heated up both directly on the furnace or in special double walled boiler.
- It can be used safely in tanks of waters.

However, in spite of benefits stated above, it includes some limitations that can be summarized as follows and as show in Table 5.8 :

- It may consist dangerous when it contacts the skin.
- It does not apply during rain or freezing circumstances.
- It protects applied material from foot traffic, freezing, rain, and continuous high humidity until fully dry.
- Avoid heavy traffic for 24 hours

Table 5.9. Material properties of joint between rigid and flexible pavement [83].

Content	Bitumen-rubber based
Density	1,17 g/cm ³
Frees Break Point	-20°C (TS EN 12593)
Softening Point	88°C (TS 120 EN 1427)
Elasticity	38 % (TS EN 13880-3)
Elastic Recovery	Rbefore=10%/ Rafter=40% (70°C ; 168±2 hours) (TS EN 13880-4)
Sagging Resistance	1 mm (at 60°C) (TS EN 13880-5)
Concrete Compatibility	Okay (TS EN 13880-9)
Conic Penetration	33 (at 25°C) (ASTM D 5329)
Min. Application Temperature	180-200°C
Max. Heating Temperature	200-220°C
Drying Time	1 hour
HS Code	6807.90.00.00.00

5.15. BOUNDARY CONDITIONS

The lateral motion of the road is constrained from the roadsides and the bottom of the road is fixed. There is no need on constraining the rotations and out of plane translations because the plane strain elements have been used. 145 kN load has been applied to the center of the axle based on the studies in the literature , the used temperature is 45 degrees Celsius based on the studies in the literature and the studies in the literature , AASHTO and GDH . It is assumed that the bottom surface of the subgrade is fixed. This means that the nodes at the subgrade bottom cannot move vertically or horizontally. The boundary nodes beside the pavement edges are horizontally reserved but they are free to move in vertical direction. The boundary conditions are shown in Figure 5.24.

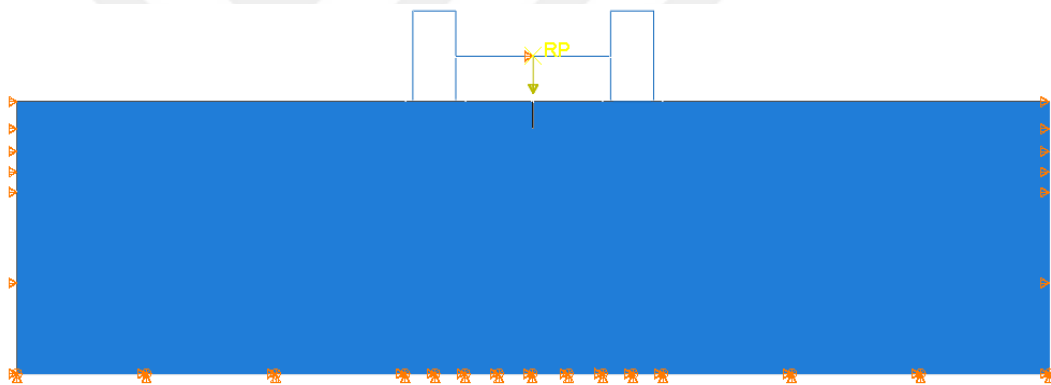

Figure 5.24. Boundary conditions.

The load has been applied as a time dependent cyclic load. The load period is 0.4 second that is corresponding to average speed of 70 km/hr. Cyclic load has been applied through 3 seconds which signifies 8 passes of the wheels.

5.16. RESULTS

- **Case-1: Axle load is on the middle of the road**

It can be seen the impact of loads on rigid pavement compared to what happens on flexible pavement as shown in results of Figure 5.25. In model analysis, rutting is

simulated as vertical movement. The displacement is considered as an answer to apply traffic repeated loads. The final magnitude of the displacement UT magnitude beneath the center of the load at the end of loading is 0.0117 cm. the results are shown in Figure 5.26.

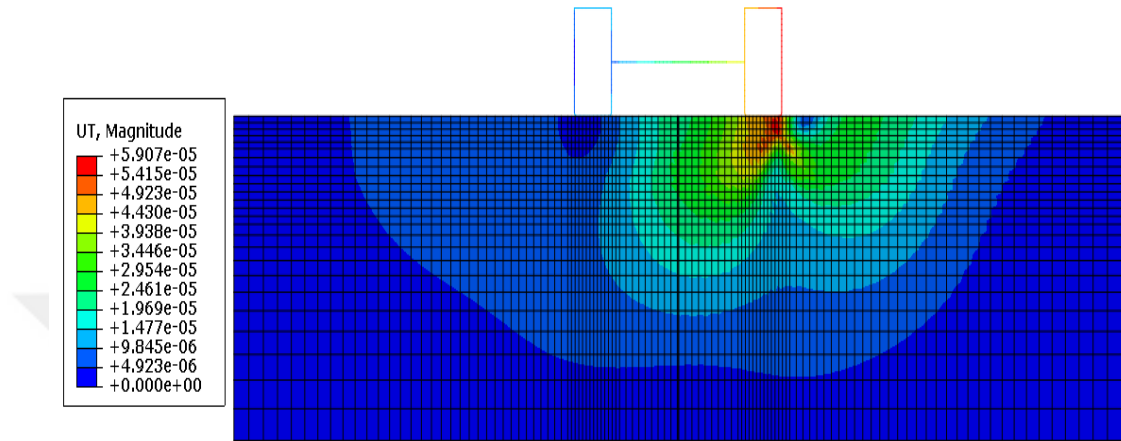

Figure 5.25. Model of displacement with repeated loads.

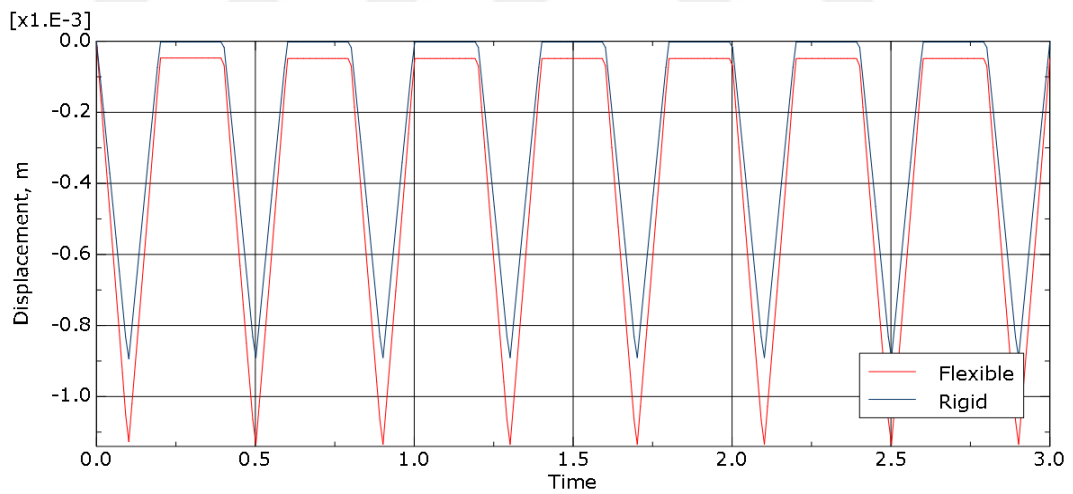

Figure 5.26. Ruth Depth for Each Passes (The displacement curve with repeated loads at the surface.

The permanent response is associated with the plastic strains and signifies the field rutting. The predictive rut depth because of the repeated loads are shown in Figure 5.27.

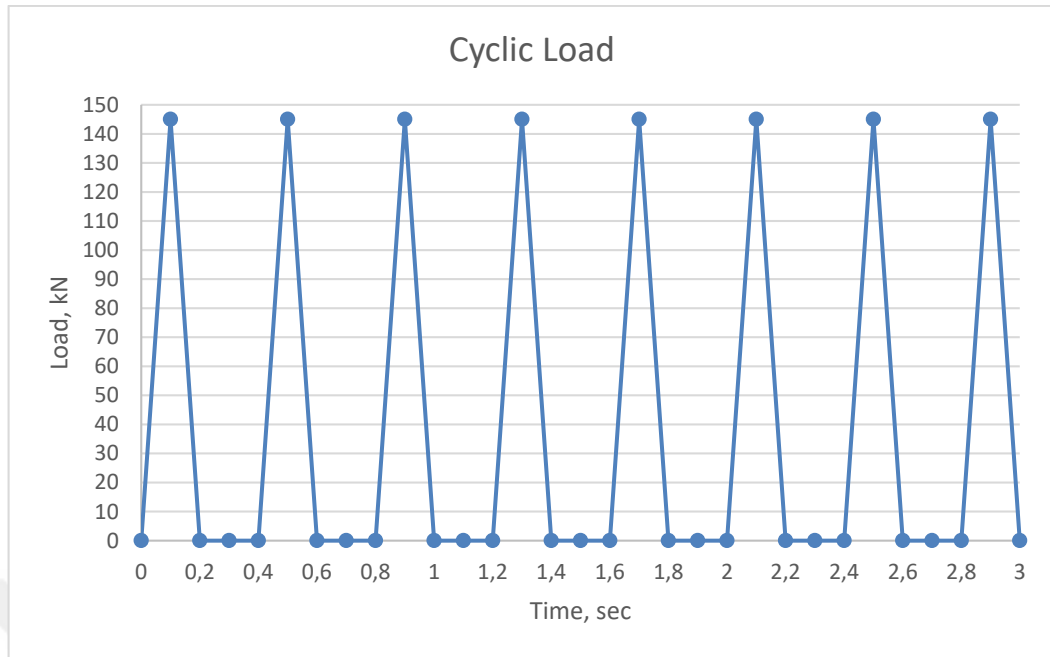

Figure 5.27. Predictive rutting due to repeated load.

Figure 5.28 clarifies the vertical plastic strain distribution gotten for wheel loads. Figure 5.29 clarifies Plastic equivalent strain while Figure 5.30 shows the plots of the vertical plastic strain profile vs. the depth from the pavement surface for the points at the center of the wheel load. Figure 5.31 clarifies the forecasted surface rut profile beneath the load.

The plastic strain vanishes at 0,80 m from the surface t the centerline of the loading area. The plastic strain at the mid-depth of the flexible layer is -0.0015 %, and at the mid-depth of the granular layer is -0.0045 %. Finally, the plastic strain at the mid-depth between the subgrade level and the point at which the plastic strain vanishes equals -0.0055 %.

Rut depth is obtained by applying Equation (1):

$$RD = 0.3 * 0.0015 + 0.25 * 0.0045 + 0.80 * 0.0055 = \tag{5.1}$$

$$0.0059 \text{ m} = 0.59 \text{ cm}$$

A comparison of prediction (0.59 cm) against field (0.6 cm) measurement indicates that results are close.

The Abaqus model developed in this study was considered validated for rutting prediction, that is considered a failure standard. The model reflects the performance of pavement and its response to static frequent loads of wheel [34].

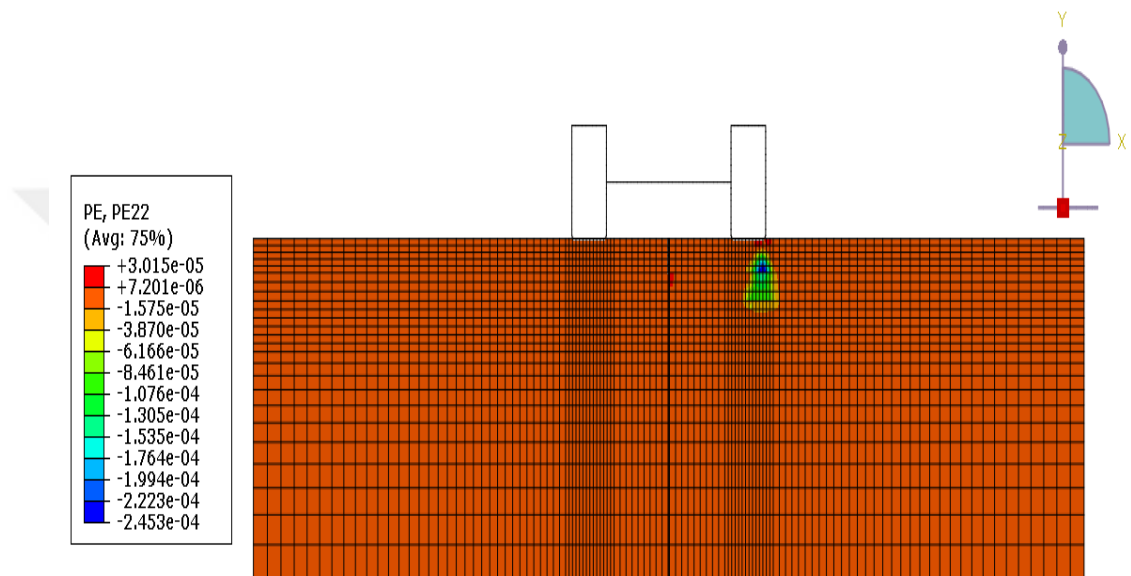

Figure 5.28. Plastic strain in the direction of “y”.

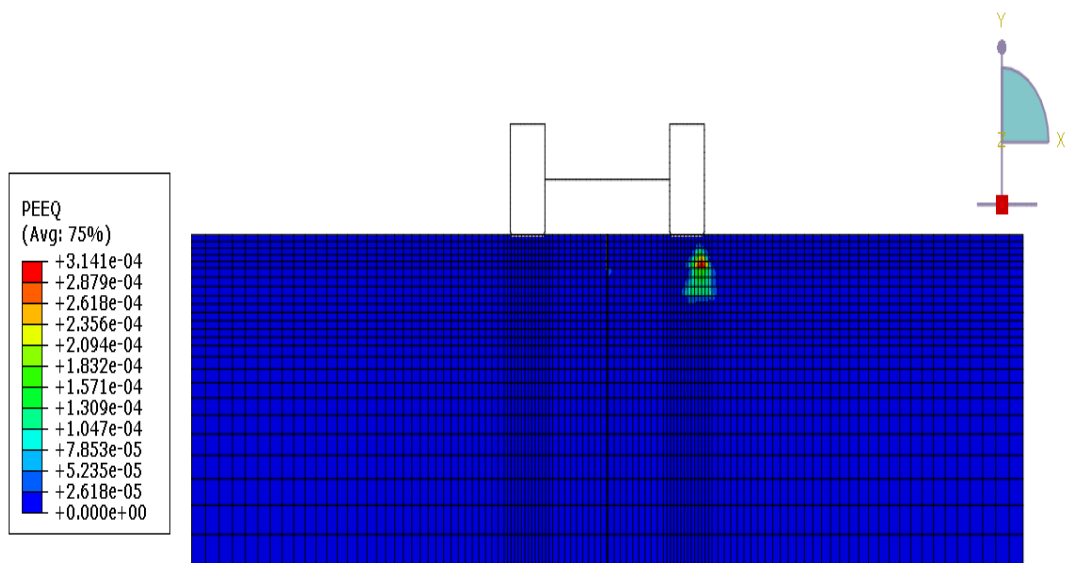

Figure 5.29. Plastic equivalent strain.

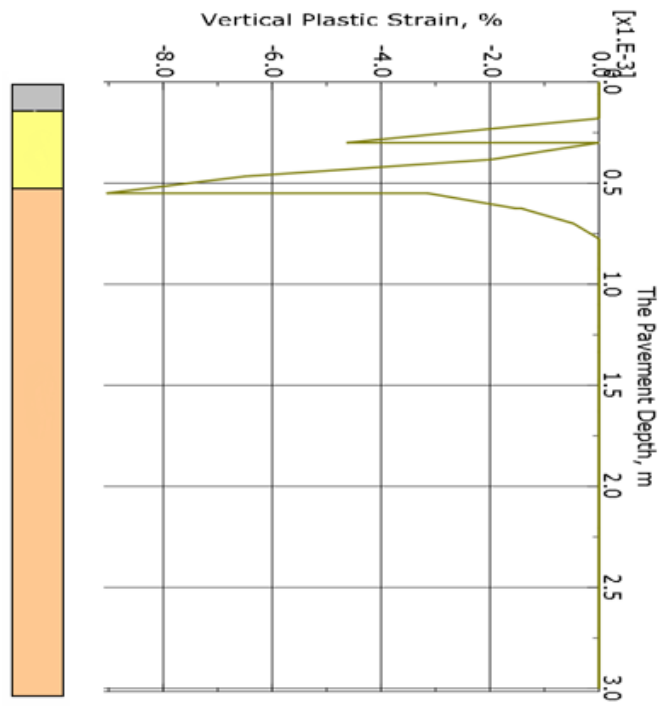

Figure 5.30. Vertical plastic strain vs pavement depth-flexible pavement side.

- **Plastic strain doesn't occur in the rigid pavement side.**

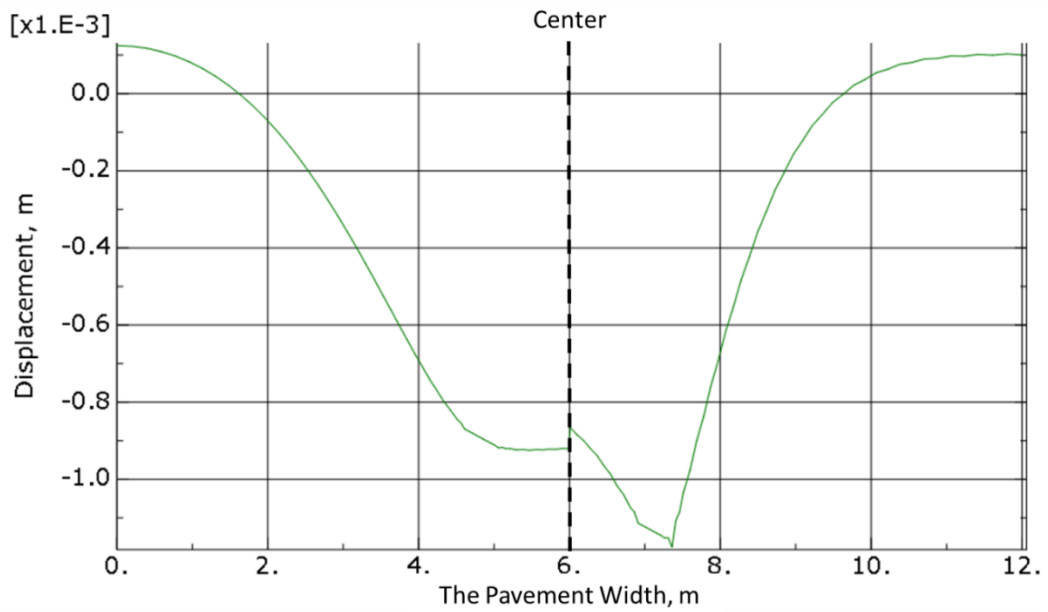

Figure 5.31. Predicted surface rut profile in the horizontal direction.

- **Case-2: Axle load is on the joint of the road**

Figure 5.32 shows the load effects on joint compared to what happens rigid and flexible paving. In model analysis, the rutting is simulated as vertical displacement. The displacement was considered as a response to apply traffic repeated loads. The final magnitude of the displacement UT beneath the center of the load at the end of loading is 0.0118 cm. the results are shown in Figure 5.33.

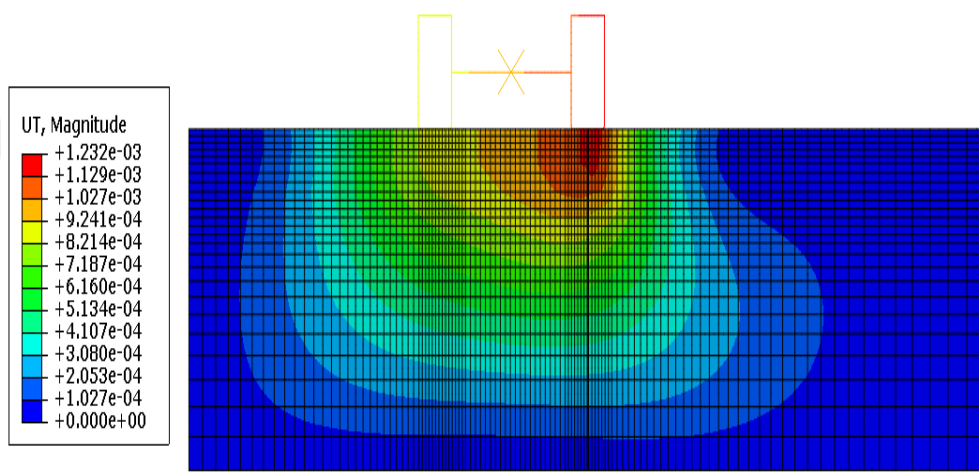

Figure 5.32. Model of displacement with repeated loads in the joint.

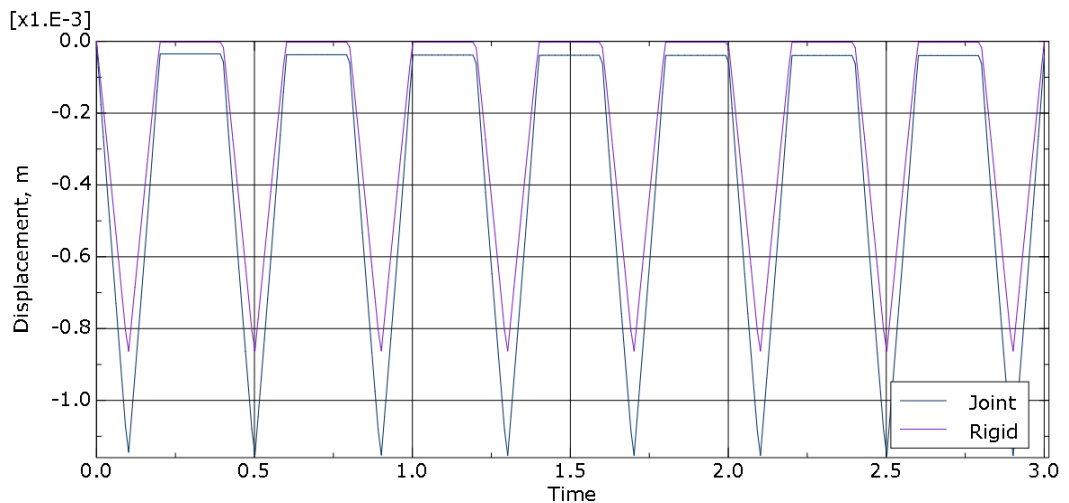

Figure 5.33. Ruth depth for each passes in the joint.

The vertical plastic strain distribution gotten for when loads on the joint is shown in Figure 5.34.

Details of Plastic strain in the direction of “y” is shown in Figure 5.35. Plots of vertical plastic strain profile vs. the depth from the pavement surface for the points at the center of the wheel load in the joint are shown in Figure 5.36. The Abaqus model developed in this study was considered validated for rutting prediction, which is considered a failure standard. The model reflects the performance of pavement and its response to static repeated wheel loads. The predicted surface rut profile beneath the load are shown in Figure 5.37.

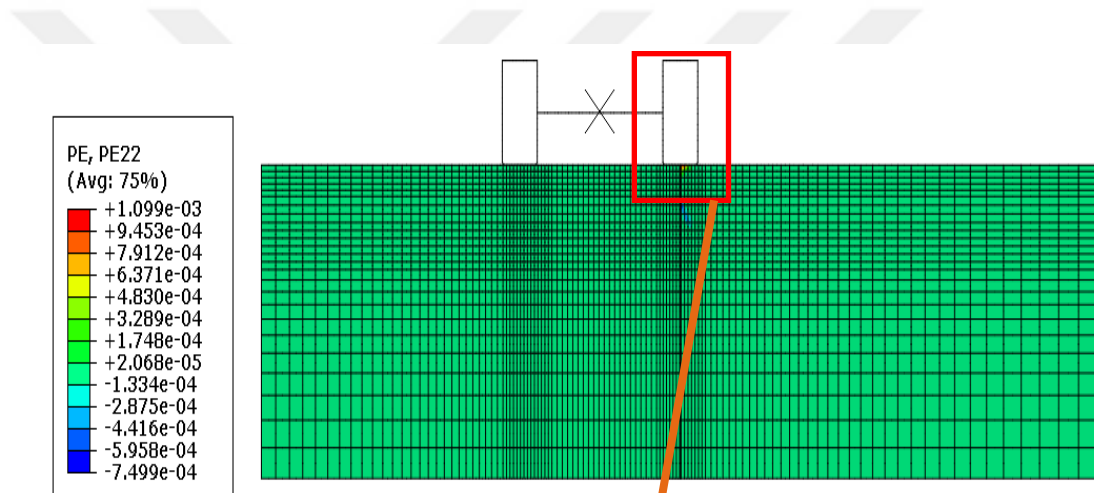

Figure 5.34. The vertical plastic strain distribution on the joint.

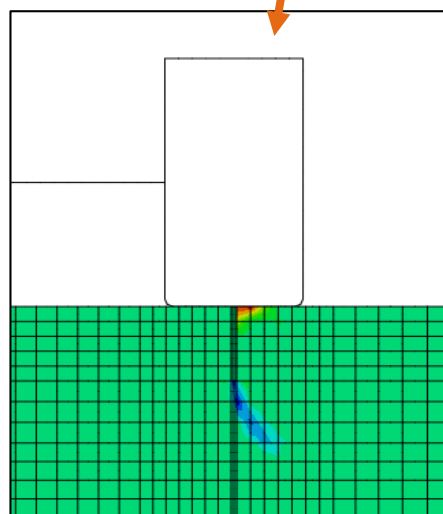

Figure 5.35. Plastic strain in the direction of “y”.

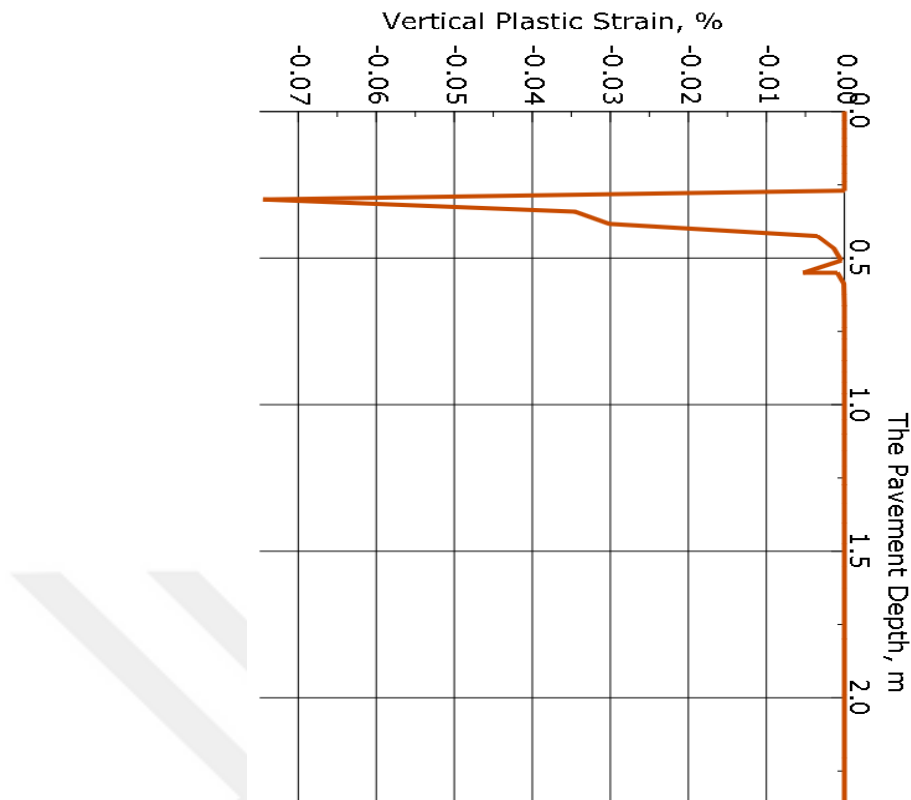

Figure 5.36. Vertical plastic strain vs pavement depth-flexible pavement side.

- Plastic strain doesn't occur in the rigid pavement side.

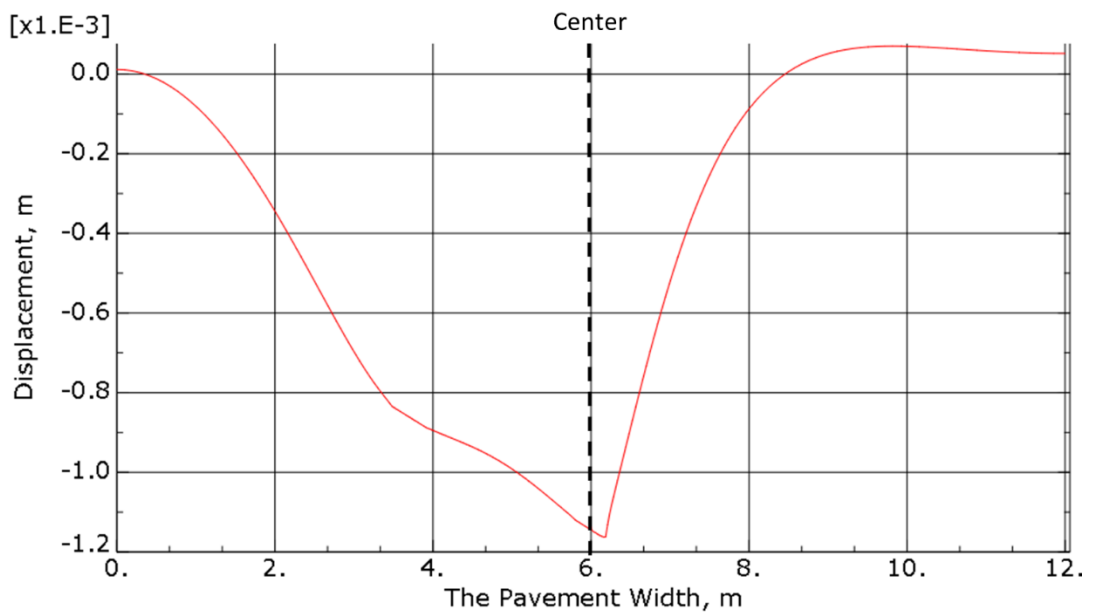

Figure 5.37. The predicted surface rut profile beneath the load.

- **Case-3 -With different load and the axel load is on the center of the road**

We also tried to have loads in violation of what was applied previously so that we can know the effect of overloads over the recognized loads according to specifications and the following are the results according to the analysis of the program.

The lateral motion of the road is constrained from the road sides and the bottom of the road is fixed. There is no need on constraining the rotations and out of plane translations because the plane strain elements have been used 10 ton load has been applied to the centre of the axel load of vehicle based on the studies in the literature, the used temperature is 45 degrees Celsius based on the studies in the literature, AASHTO and GDH.

It is assumed that the bottom surface of the subgrade is fixed. This means that the nodes at the subgrade bottom cannot move vertically or horizontally. The boundary nodes beside the pavement edges are horizontally reserved but they are free to move in vertical direction. The boundary conditions are shown in Figure 5.38.

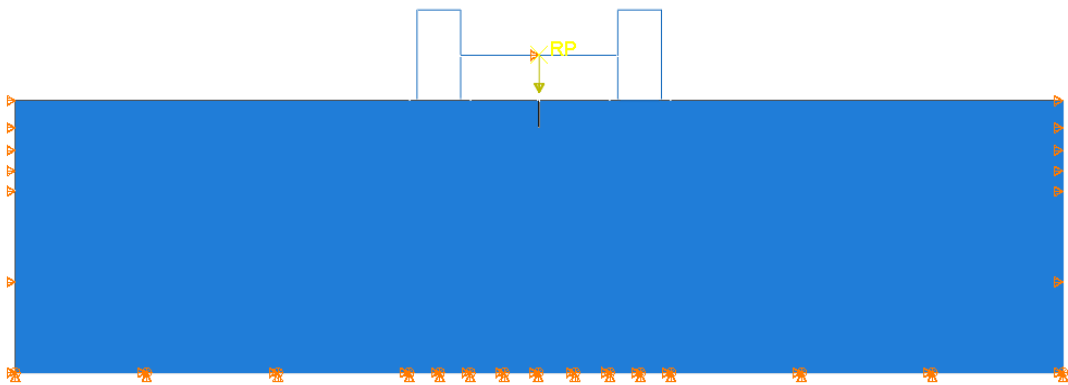

Figure 5.38. Boundary conditions.

The load has been applied as a time dependent cyclic load. The load period is 0.4 second that is corresponding to average speed of 70 km/hr. Cyclic load has been applied through 30 seconds which signifies 1000 passes of the wheels.

It can be seen the impact of loads on rigid pavement compared to what happens on flexible pavement as shown in results of Figure 5.39. In model analysis, rutting is simulated as vertical movement. The displacement is considered as an answer to apply traffic repeated loads. The final magnitude of the displacement UT beneath the center of the load at the end of loading is 7 cm. the results are shown in Figure 5.40. Axel is on the middle of the road.

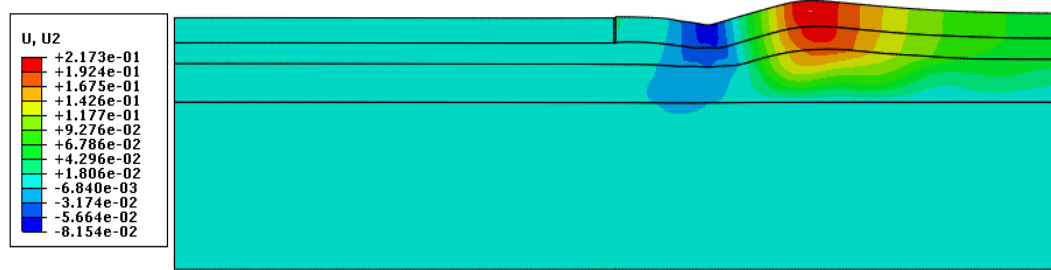

Figure 5.39. Axel is on the middle of the road.

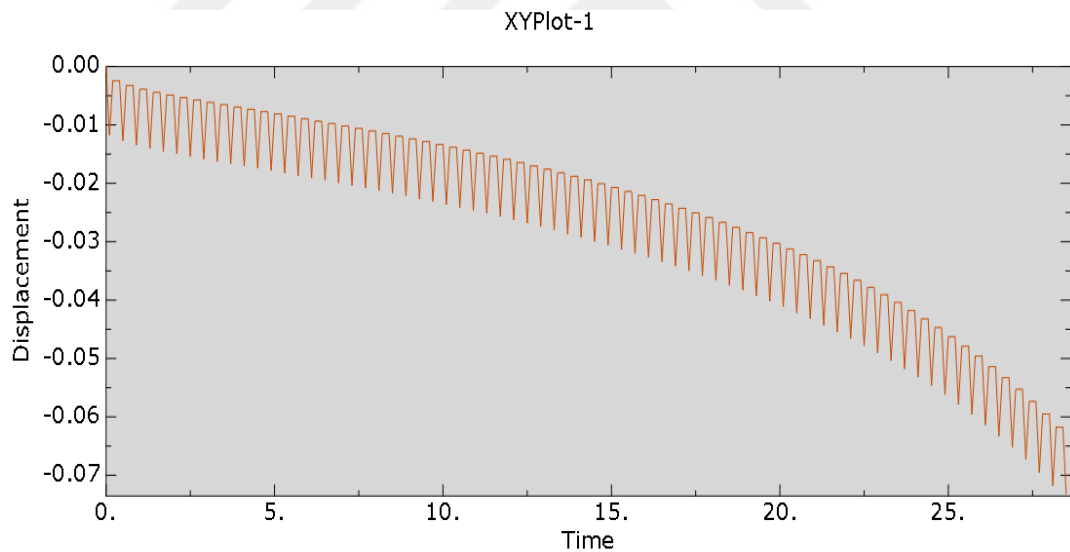

Figure 5.40. Ruth Depth for Each Passes.

Figure 5.41 clarifies the vertical plastic strain distribution gotten for wheel loads. Figure 5.42 clarifies Plastic equivalent strain while Figure 5.43 shows the plots of the vertical plastic strain profile vs. the depth from the pavement surface for the points at the center of the wheel load. Figure 5.44 Vertical displacement along the pavement surface. 0 begins from rigid pavement.

The plastic strain vanishes at 1.25 m from the surface to the centerline of the loading area. The plastic strain at the mid-depth of the flexible layer is -0.04 %, and at the mid-depth of the granular layer is -0.05 %. Finally, the plastic strain at the mid-depth between the subgrade level and the point at which the plastic strain vanishes equals -0.055 %.

Rut depth is obtained by applying Equation:

$$RD = 0.3 * 0.04 + 0.25 * 0.05 + 1.25 * 0.055 = 0.0932 \text{ m} = 9.32 \text{ cm} \quad (5.2)$$

A comparison of prediction (9.32 cm) against field (9.30 cm) measurement indicates that results are close. The Abaqus model developed in this study was considered validated for rutting prediction, that is considered a failure standard. The model reflects the performance of pavement and its response to static frequent loads of wheel [34].

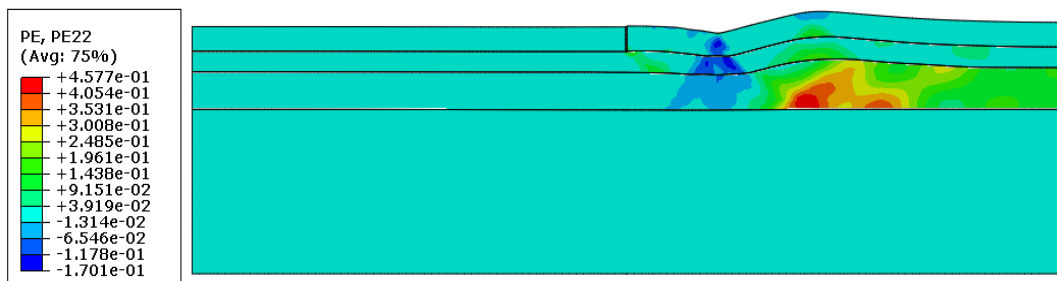

Figure 5.41. Plastic strain in the direction of “y”.

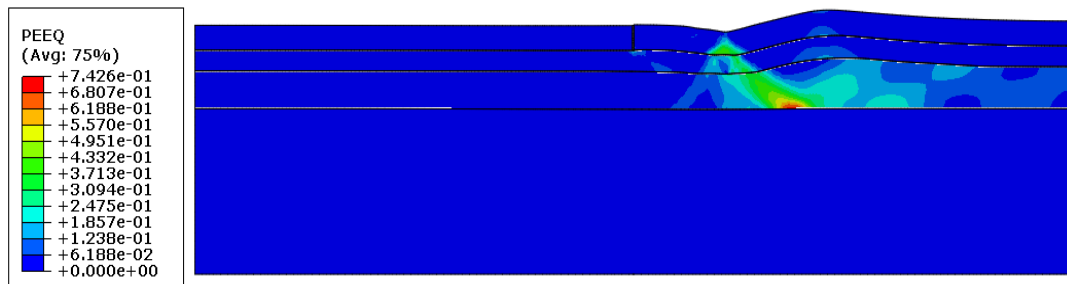

Figure 5.42. Plastic equivalent strain.

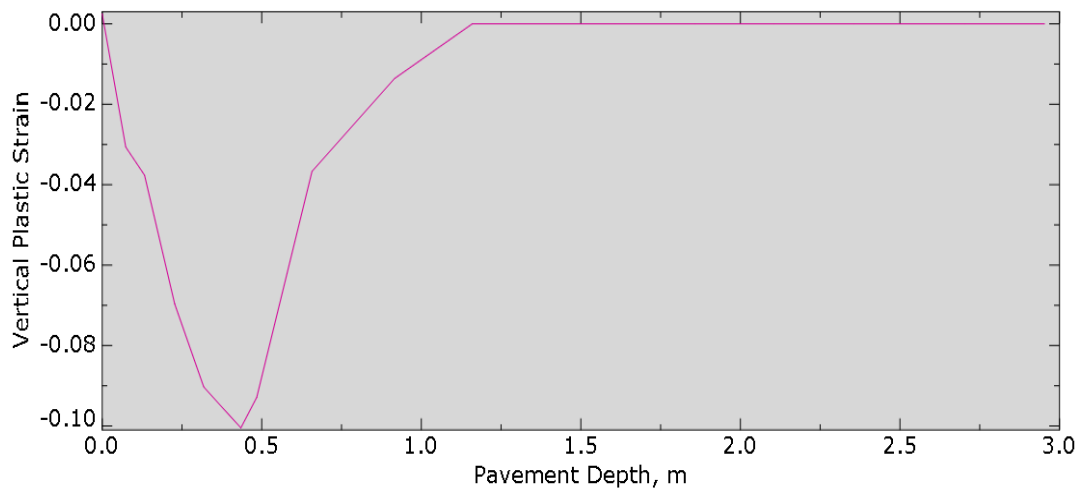

Figure 5.43. Vertical plastic strain vs pavement depth-flexible pavement side.

- **Plastic strain doesn't occur in the rigid pavement side.**

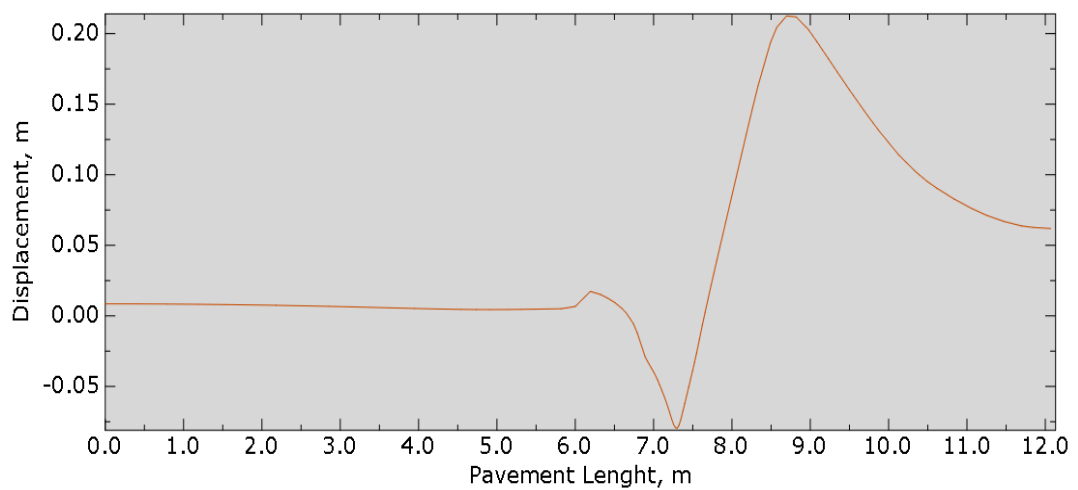

Figure 5.44. Vertical displacement along the pavement surface.

The effect of stress on rigid pavement and note the difference between the stress that occurs for rigid pavement and flexible pavement has shown in Figure 5.45. Stress distribution on the pavement.

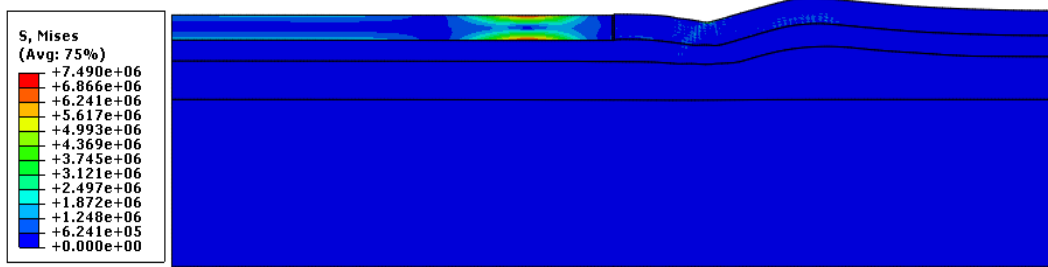

Figure 5.45. Stress distribution on the pavement.

- **Case-4: With different load and the axel load is on the Joint of the road**

It can be seen the impact of loads on joint as shown in results of Figure 5.46. In model analysis, rutting is simulated as vertical movement. The displacement is considered as an answer to apply traffic repeated loads. The final magnitude of the displacement UT beneath the center of the load at the end of loading is 0.01 cm. The results are shown in Figure 5.47. As for the wheel on the joint.

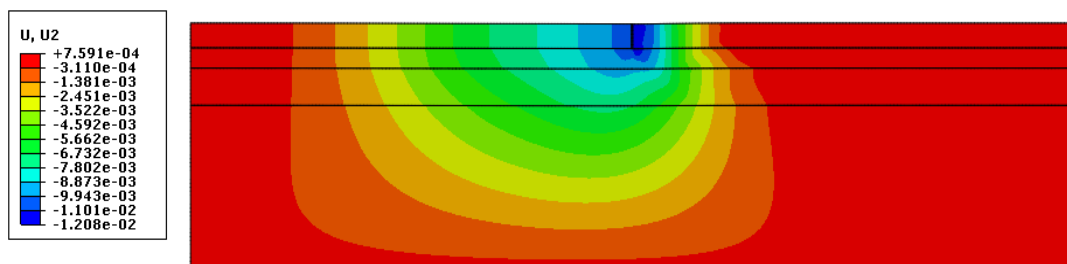

Figure 5.46. Wheel on the Joint.

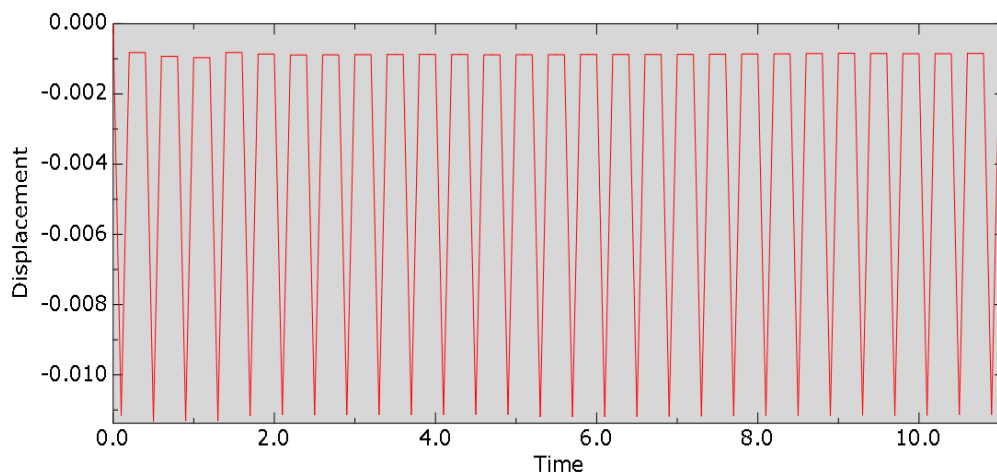

Figure 5.47. Ruth Depth for Each Passes.

Figure 5.48 clarifies the vertical plastic strain distribution gotten for wheel loads. Figure 5.49 clarifies Plastic equivalent strain while Figure 5.50 shows the plots of the vertical plastic strain profile vs. the depth from the pavement surface for the points at the center of the wheel load. Figure 5.51 clarifies the forecasted surface rut profile beneath the load.

In the joint the plastic strain vanishes at 0.75 m from the surface to the centerline of the loading area. The plastic strain at the mid-depth of the joint is -0.0001 %, and at the mid-depth of the granular layer is -0.0001 %. Finally, the plastic strain at the mid-depth between the subgrade level and the point at which the plastic strain vanishes equals -0.004 %.

Rut depth is obtained by applying Equation:

$$RD = 0.3 * 0.0001 + 0.25 * 0.0001 + 0.75 * 0.004 = 0.0030 \text{ m} = 0.30 \text{ cm} \quad (5.3)$$

A comparison of prediction (0.30 cm) measurement indicates that results are close [34].

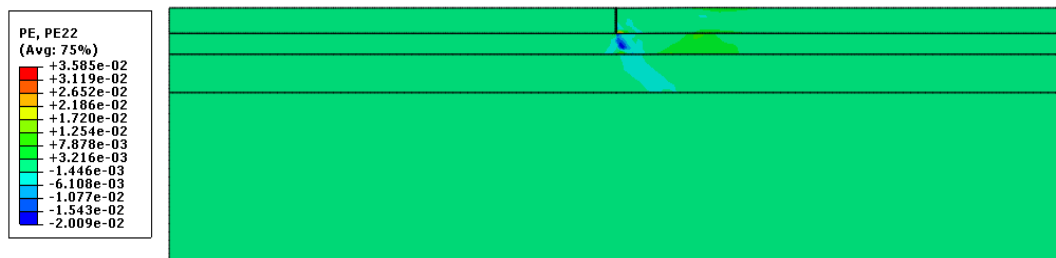

Figure 5.48. Plastic strain in the direction of “y”.

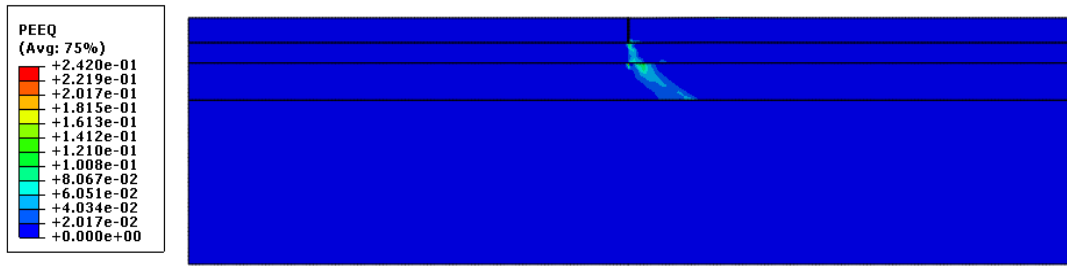

Figure 5.49. Plastic equivalent strain.

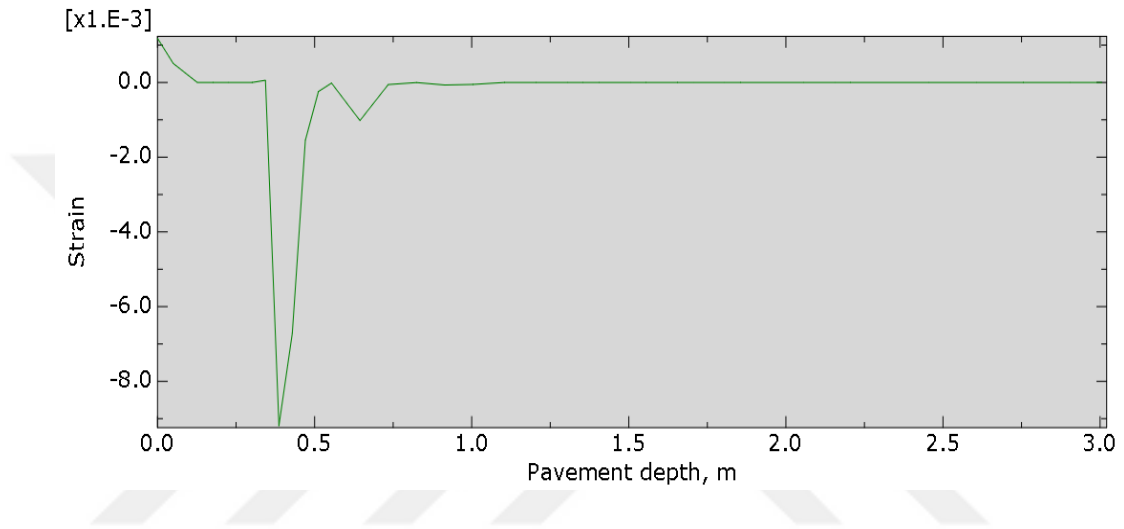

Figure 5.50. Vertical plastic strain vs pavement depth.

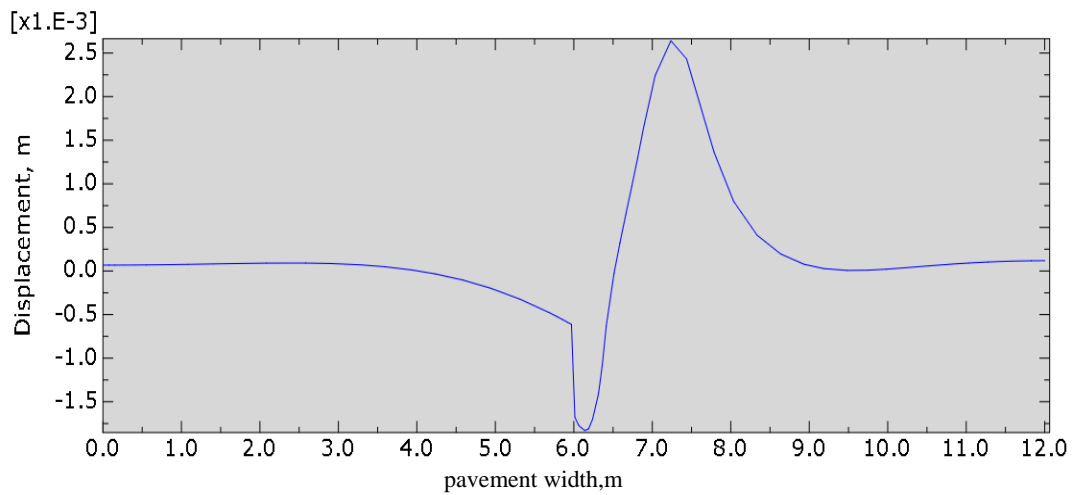

Figure 5.51. Vertical displacement along the pavement surface.

5.17. SUMMARY FOR THE RESULT

It used Abaqus software to analyze the hybrid pavement for the short time in which we can obtain results compared to laboratory and field tests. The results that we will obtain are considered preliminary, and then they will be developed through laboratory and field work.

Also, in this study, the outputs were entered according to the Turkish specifications, and after reviewing some previous research similar to this work as well as according to the American specifications, where a larger axel load was then inserted from the specifications to know the damages of the extra loads that are going on the pavement in violation, also because the program is taking in a long time to analyze the results, four cases (2 cases in the middle of the pavement and 2 cases in the joint with different load) were done, each case is different from the other in the number of times the load that passes on the pavement as well as on the joint between the rigid and flexible pavement even though the increase in the number of times load passes ,the results is increasing in the collapse of the pavement layers, but the deformation occurred from a little passes and was by a slight amount and then increased with the increasing of the number of pregnancy passes.

The deformations that occurred in the flexible pavement were more than the rigid pavement. Also observed the stresses generated in rigid pavement greater than flexible pavement. When applied the pressure, the strain developed in flexible pavement is more than rigid pavement. The analysis have shown the thickness of flexible pavement and rigid pavement also effect on the strain, stress and deformation of both of them.

As shown in Figure 5.52. the parameter and the results of four different case;

- In the first case with 145 kn, and the axel load is in the center of road. The rut depth (0.56 cm). Cyclic load has been applied through 3 seconds which signifies 8 passes of the wheels, and the average of speed is 70 km/hr. The temperature applied as 45c°.

- In the second case with 145 kn, and the axel load is on the joint between the fixable and rigid pavement. The rut depth (0.04 cm). Cyclic load has been applied through 3 seconds which signifies 8 passes of the wheels, and the average of speed is 70 km/hr. The temperature applied as 45c°.
- In the third case with 10 ton, and the axel load is in the center of road. The rut depth (9.32 cm). Cyclic load has been applied through 30 seconds which signifies 1000 passes of the wheels, and the average of speed is 70 km/hr. The temperature applied as 45c°.
- In the fourth case with 10 ton, and the axel load is on the joint between the fixable and rigid pavement. The rut depth (0.30 cm). Cyclic load has been applied through 30 seconds which signifies 1000 passes of the wheels, and the average of speed is 70 km/hr. The temperature applied as 45c°.
- The rutting in the rigid pavement did not occur in the four cases .

	PARAMETERS	RUTTING AMOUNTS	
		Rigid	Flexible
Case 1	8 passes	0 cm	0,59 cm
	14.5 ton axle load		
	axle load is in the centre		
	70 km/h		
	45 celcius degree		
Case 2	8 passes	0 cm	0,04 cm
	14.5 ton axle load		
	axle load is on the joint		
	70 km/h		
	45 celcius degree		
Case 3	1000 passes	0 cm	9.32 cm
	10 ton axle load		
	axle load is in the centre		
	70 km/h		
	45 celcius degree		
Case 4	1000 passes	0 cm	0,30cm
	10 ton axle load		
	axle load is on the joint		
	70 km/h		
	45 celcius degree		

the rutting amount decreased because much of the load meet by rigid side

the rutting amount decreased because much of the load meet by rigid side

Figure 5.52. the parameter and the results of four different case.

5.18. COST ANALYSIS

It is necessary to conduct further studies on the effect of increased traffic on pavement both in urban and rural roads. Development of traffic is resulted the modernization and building of roads. This demands additional studies to select road

pavement. Organizations seek to take more comprehensive and educated investment decisions because the selection of pavement type have a great effect on future costs and service level for users. In general, decision of pavement types depends on atmospheric elements, level of traffic, soil circumstances, and costs of construction. In various cases, the initial cost of construction is considered the major cost and rehabilitation and future maintenance may be forgotten. Evaluation of project life cycle is not the unique issue, we must calculate the related cost in order to create a Life-Cycle Cost Analysis (LCCA) of transportation infrastructure including pavements. On the long-term, governmental organizations may save money by looking to pavement life on the long-term [36].

In order to compare the cost of rigid pavement with flexible pavement or determine the cost of project that is usually LCCA, it is a process which compares the long-term economic value for comparison alternatives and results which can be beneficial as support tool decision.

According to AASHTO, life-cycle costs “indicate to the entire costs convoluted in delivering a wharf through its whole life cycle” [30]. This means that the entire platforms alternatives have been assessed by looking to users and different agencies costs that includes primary construction costs, agency costs, rehabilitation costs in future, and maintenance and competence operations. As well as costs of users are results of several different problems including increased delays costs, increased vehicle costs of operations or changes in accident costs because of the future maintenance procedure [36].

Costs analysis for hybrid pavement is based on many significant factors which lie in cost life cycle that must be taken into account. These steps are included in LCCA methodology as shown in Figure 5.53 [36].

The forecasted surface rut profile beneath the load can be explained as follows:

- Create substitute design strategies.
- Determine time of activity.
- Approximate costs of agency.

- Approximate costs of user.
- Conclude life-cycle cost.

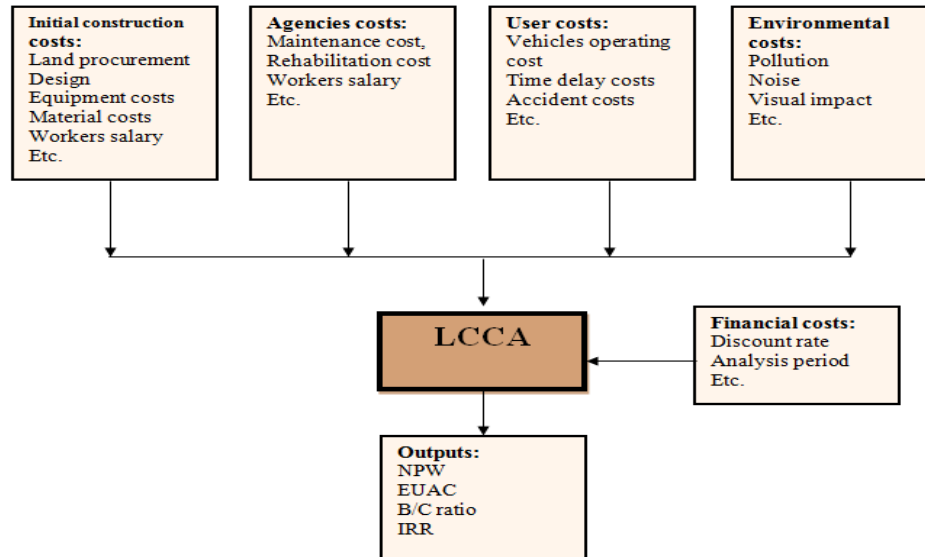

Figure 5.53. The LCCA methodology are as follows [36].

So, each input in the model studied carefully. Other uncertainties for any project can be listed as follows [36]:

- The economic status may change that may affect on discount ratio and price of unit.
- Prices of oil that effect on most of the goods may fluctuate.
- Enhanced materials may be developed.
- Enhanced rehabilitation and maintenance practiced may be developed.
- Change may occur in societal needs and leadership culture for example, public transportation or cycling may become more popular and people may became less depend on using their vehicles.
- Since the discount ratio has great effect on selection of materials, it is necessary to get more information about this factor in construction industry and road projects.
- Many pavement behavior scenarios may be entered in this model.

It must be confirmed that the analysis of life cycle cost is only a tool to help those who take decisions associate with the selection of pavements and not the decision itself. Furthermore, this tool does not give a clear answer about any pavement to be selected. Instead, it helps on providing a general review on total cost through the life cycle and give an idea about the level of traffic through which the concrete pavement is selected. There might be other reasons of selections instead of pure economic ones. Organizations may interest in preserving the competition in pavements markets in order to avoid the monopoly of one of those pavements. Moreover, other economic factors may exceed the environmental factors that discussed previously [36]. Briefly, it mentioned before, it is difficult to approximate the cost because of change in many cases depended by the cost.

PART 6

CONCLUSION

Rigid pavements have been used commonly besides the use of flexible pavements in European countries such as France, Austria, Germany, Holland, Belgium etc. and as well as the United States and most of countries. The specific situation of each country and some parameters (external dependence on petroleum, difficulties in material supply, past application experiences, climatic conditions, passenger/freight transportation rates, economical resources spent for maintenance/repair etc.) are taken into consideration in making this choice.

When the current situation in Turkey is examined for the road network in the responsibility of GDH for 2019, there is a total of 67.333 km of road networks, including 2.159 km of highway, 31.021 of state roads and 34.153 km of provincial roads. 58% of this road network is surface treatment, 36% is HMA, about 6% is composed of stone block, stabilized and earth roads but correspondingly there has been only a little amount of rigid pavement applications which are generally experimental purposes in Afyonkarahisar-Emirdağ road (2 km), Hasdal-Kemberburgaz road (3.5 km) and Ordu-Ulubey road (1.6 km).

89.2% of passenger transportation and 89.8% of freight transportation in 2019 was carried out on highways in Turkey. It is 45% on average in European countries and 69% in the USA. In addition, the number of motor vehicles in Turkey is 22.940.636 and increasing considerably year by year.

Turkey is among the top cement manufacturing countries in the world but correspondingly it is a petroleum importing country.

In the light of information above it is believed that rigid pavements can be preferred in terms of transferring the traffic load to the subgrade more effectively and causing less deformation due to rapidly increasing vehicle traffic and passenger/freight transportation amounts in Turkey.

In this study, It is aimed to increase potential utilization areas of cement based (rigid) pavements, instead of flexible pavements which is a petroleum derived pavement type and to benefit from the advantages of rigid pavements such as resistance to deformations (especially rutting), long maintenance duration, long service life, high resistance to temperature changes

With this study, it is aimed to attain the advantages of both pavements applying them together at the same road. The right (first) lane is designed as rigid and the others are designed as flexible and called “hybrid pavement” thus combining their advantages on the same road.

For this purpose, with the Abaqus software, it is desired to observe the rutting failure differences which are simulated as vertical displacement of rigid and flexible pavements and also to know the possibility of using them together at the same road that is called as “Hybrid”. According to the results, the most problematic area was predicted as the joints of hybrid pavement. Because rutting amounts of flexible and rigid pavements especially on joints would be different and this would be an elevation difference that may cause a trouble while changing lanes even an accident.

For this purpose, four different scenarios with various parameters (traffic amount, axle load, load on the center/joint, velocity, temperature) were applied, and the worst situation was attained in case 3 with 9,32 cm rutting amount on flexible side and 0 cm on rigid side. This amount may be problematic but when the case 4 which axle load is on the joint was applied, the rutting amount decreased to 0,3 cm because much of the load was met by rigid side and this result can be negligible and proves the efficiency/applicability of Hybrid Pavement in terms of rutting amount.

Especially for rutting deformation, climatic conditions are very important parameters that should be taken into consideration. With the increase of temperature value, the rutting deformation in flexible pavements also increase as in the literature. So, it is also important to observe the rutting depth differences due to temperature. With further studies, combined circumstances (traffic loading effect and thermal loading) should also be studied in order to observe the rutting behavior of flexible pavements under high and low temperatures.

In Turkey according to Pavement Design Guide of GDH, average daily 8.2 tons axle load traffic amount for the planned route should be obtained and considered. But due to the constraints such as need for a workstation computer and a long process time, in Abaqus software, 1000 passes of 10 tons axle load was simulated for rutting amounts.

Despite some disadvantages of rigid pavement, as it can be seen from the literature and from the results of this study, rigid pavements are much more resistant to rutting deformations and thus can be recommended to apply especially roundabouts and intersections with traffic lights where especially this kind of deformations occur.

When a wheel of the vehicle is on rigid and the other one is on flexible side, braking of vehicle may be problematic due to different friction coefficients and this situation needs to be researched and studied in future studies.

Both pavement type has different repair/rehabilitation periods and process so a sustainable repair/rehabilitation process of hybrid pavement should be created considering periods, economy, traffic flow, public procurement methods and a repair/rehabilitation guide should be prepared.

Hybrid pavement is thought to be applied especially for state roads or highways which have a considerable amount of heavy vehicle traffic and also have minimum 2x2 lanes.

In summary, in Turkey as well as in various countries of the world, a number of parameters such as regional climate conditions, economic criteria, traffic amount, service life, maintenance/repair needs etc. and the advantages of each type of pavement should be taken into consideration and through optimization studies to be carried out, the most suitable pavement type or both of them together (hybrid pavement) as stated in this study should be applied.



REFERENCES

1. El-Basyouny, M. M. and Witczak, M. “Development of the fatigue cracking models for the 2002 design guide”, *Paper presented at the Annual Meeting of the Transportation Research Board*, Washington, DC, 10-12 (2005).
2. Sotiriadis, G., “Asphalt transport pavements: causes of deterioration, methods of maintenance and suggestions/guidelines for new smart methods”, *Cyprus University of Technology Repository*, Cyprus, 12-20 (2016).
3. Miehe, C., and Göktepe, S., “A micro–macro approach to rubber-like materials. Part II: The micro-sphere model of finite rubber viscoelasticity”, *Journal of the Mechanics and Physics of Solids*, 53 (10): 2231-2258 (2005).
4. Karayolları Genel Müdürlüğü, “Dünden Bugüne Karayolları Tarihçesi”, *Yapı ve Altyapı Bakanlığı*, Ankara, 15-16 (2014).
5. Çetin, O., “Beton Yollarda Yeni Teknolojiler Silindirle Sıkıştırılan Beton Yol”, *Yüksek Lisans Tezi, İstanbul Teknik Üniversitesi Fen Bilimleri Enstitüsü*, İstanbul, 26-28 (2009).
6. İsmail Y., “Feasibility of rigid pavements in village roads: Eskipazar example”, *Master Thesis, Transportation -Civil Engineering, Karabük Üniversitesi*, Karabük, Turkey, 56-58 (2019).
7. World Highways, “Road Technology”, *CRC Press*, London, UK, 230-35 (2014).
8. Acikgöz, O., and Rauf, R., “Analysis of Parameters Affecting Permanent Deformation in Road Pavement Based on Measurement Data from LTPP-Roads”, *Master Thesis, Göteborg University*, Sweden, 34-40 (2010).
9. Dawson, A. and Kolisoja, P., “Permanent Deformation”, *Report on Task 2.1, University Of Nottingham*, London, UK, 10-12 (2004).
10. Loizos A., "Specific issues of pavements", *Course Notes, Publisher NTUA*, Athens, 12-15 (2012).
11. Dai, S., Skok, E., Westover, T., Labuz, J., and Lukanen, E., “Pavement rehabilitation selection”, *Report No. MN/RC 2008-06. Minnesota Department of Transportation*, St. Paul, 67-71 (2008).
12. Long, B., and Shatnawi, S., “Structural evaluation of rigid pavement sections”, *Road Materials and Pavement Design*, 1(1-2): 97-117 (2000).

13. Patil, V., Sawant, V., and Deb, K., "Finite element analysis of rigid pavement on a nonlinear two parameter foundation model", **International Journal of Geotechnical Engineering**, 6 (3): 275-286 (2012).
14. Thomas, A. V., Kalidindi, S. N., and Ananthanarayanan, K. A. B. T., "Risk perception analysis of BOT road project participants in India", **Construction Management and Economics**, 21(4): 393-407 (2003).
15. David, L., "Model and realization Amprincipe", **Printing Technic Printing "Carrefours Giratoires En Béton**, Paris, France, 42-48 (2009).
16. Muench, A. A., Lada, E. A., and Lada, C. J., "Modeling the near-infrared luminosity functions of young stellar clusters", **The Astrophysical Journal**, 533 (1): 358(2000).
17. Patil, S. M., Deshpande, A. S., Bhalerao, R. R., Metkari, S. B., and Patil, P. M., "A three-dimensional finite element analysis of the influence of varying implant crest module designs on the stress distribution to the bone", **Dental Research Journal**, 16 (3): 145 (2019).
18. Cojocaru, R., Pais, J. C., Radu, A., and Budescu, M., "Modeling of Airport Rigid Pavement Structure Made of RCC and Recycled Cement Concrete for Complex Configuration of Landing Gears", **In Advanced Materials Research**, 649 (1): 254-257 (2013).
19. Internet: Civil Blog, "Forms of Failure", <http://civilblog.org/2016/01/27/5-forms-of-failure-in-rigid-pavement/> (2019).
20. Highway Research Board, "Special Report 61D: The AASHO Road Test Report 4, Materials and Construction," **National Academy of Sciences-National Research Council**, Washington, D. C, 173 (1962).
21. Highway Research Board, "Special Report 61G: The AASHO Road Test Report 7, Materials and Construction," **National Academy of Sciences-National Research Council**, Washington, D.C, 59 (1962D).
22. Highway Research Board, "Special Report 18: The AASHO Road Test," Washington, D.C., (1954).
23. Highway Research Board, "Special Report 61B: The AASHO Road Test Report 2, Materials and Construction," **National Academy of Sciences-National Research Council**, Washington, D.C., 162 (1962).
24. Highway Research Board, "Special Report 22: The AASHO Road Test," Washington, D.C., (1955).
25. Maharaj, D. K., and Gill, S., "Development of Design Chart for Flexible Pavement By Finite Element Method", **International Journal of Latest Research in Engineering and Computing**, 2 (2): 8-23 (2014).

26. Hadi, M. N. S., and Arfiadi, Y., "Optimum rigid pavement design by genetic algorithms", *Computers and Structures*, 79 (17): 1617-1624 (2001).
27. Razouki, Z. and Al-Muhana, A., "Proceedings of the Institution of Civil Engineers – Transport", *ISSN 0965-092X*, 158 (4): 219-230 (2005).
28. Westergaard, C., "analysis for rigid pavement design", *Chapter 29, Rigid Pavement Design*, Nptel, 7-9 (2007).
29. Mallick, R. B., and El-Korchi, T., "Pavement engineering: principles and practice", *CRC Press*, London UK, 10-12 (2017).
30. Aashto Guide for Design of Pavement Structures", *American Association of State Highway and Transportation Officials*, Washington, D.C., (1993).
31. Darter, M., "Report on the 1992 U.S. Tour of European Concrete Highways", *Federal Highway Administration*, Washington, D.C., 23-26 (1993).
32. Luccioni, B. M., and Luege, M. "Concrete pavement slab under blast loads", *International Journal of Impact Engineering*, 32 (8): 1248-1266 (2006).
33. Internet: Abaqus Benchmarks Guide, "Abaqus Benchmarks Guide", <http://dsk.ippt.pan.pl/docs/Abaqus/v6.13/books/bmk/default.htm?startat=ch01s01ach10.html> (2019).
34. Al-Khateeb, L. A., Saoud, A., and Al-Msouti, M. F., "Rutting prediction of flexible pavements using finite element modeling", *Jordan Journal of Civil Engineering*, 159 (298): 1-18 (2011).
35. Ganesh, B., Vijaykumar, B., "Analytical Study of Flexible and Rigid Pavement Subjected to Combined Bending and Shear by Ansys. Students of structural engineering, *JSPM's Imperial College of Engineering and research*, 3 (3): 2395-4396 (2017).
36. Scheving, A. G., "Life cycle cost analysis of asphalt and concrete pavements", *Reykjavík University*, Island, UK, 11-12 (2011).
37. Walls III, J., and Smith, M. R., "Life-cycle cost analysis in pavement design-interim technical bulletin", *No. FHWA-SA-98-079*, UK, London, 79-89 (1998).
38. Alaa H. and Adel A., "Evaluation of rutting depth in flexible pavement by using finit element analysis and local empirical model", *American Journal of Engineering and Applied Sciences*, 5 (2): 163-169 (2012).
39. Kök, E., " Karayolu ve Havaalanı Üstyapı Tasarım Yöntemleri, Karşılaştırılması ve Türkiye Uygulamaları", Yüksek Lisans Tezi, *İstanbul Teknik Üniversitesi Fen Bilimleri Enstitüsü*, İstanbul, 1-3 (2008).
40. Boztepe, M., "Beton Yollardaki Farklı Yüzey Tiplerinin Gürültü Düzeyi Üzerindeki Etkisinin İncelenmesi", Yüksek Lisans Tezi, *İstanbul Teknik Üniversitesi Fen Bilimleri Enstitüsü*, İstanbul, 5-7 (2011).

41. Yurdakul, Y., "Köy Yollarının Geometrik Tasarımı Yapılandırılması ve Trafik Güvenliği Yönünden İrdelenmesi", Yüksek Lisans Tezi, *Gazi Üniversitesi Fen Bilimleri Enstitüsü*, Ankara, 9-11 (2006).
42. Internet: Factors Influencing Pavement Design, "Sadananda is a civil engineer and is an author, editor and partner of the constructor since 2016", <https://theconstructor.org/transportation/factors-affecting-pavement-design/12849/> (2019)
43. Ecevit, O., "Karayollarında Rijit Üstyapı Uygulamaları ve Tasarımı", Yüksek Lisans Tezi, *İstanbul Teknik Üniversitesi Fen Bilimleri Enstitüsü*, İstanbul 25-63 (2007).
44. Internet: Pavement Types and Usage, "Derzli donatılı Beton Kaplama İmalatı", <file:///C:/Users/hp/Downloads/Pavements%20Types.pdf> (2005).
45. Internet: South African National Roads Agency Soc. Ltd., "Rijit ve Esnek Üstyapılarda Meydana Gelen Yük Dağılımları", https://www.nra.co.za/live/content.php?Item_ID=65/ (2017).
46. Internet: Ronald Rodriguez Tovar, "Slide share", <https://www.slideshare.net/ronaldrodrigueztovar3/nociones-sobre-compactadores/> (2020).
47. Internet: Simple Asphaltic Concrete Roads, "Design and Properties", <https://www.aboutcivil.org/simple-asphaltic-concrete-roads.html/> (2019)
48. Types of pavements, "Strucore", <http://strucore.com/2017/09/18/types-of-pavements/>(2018).
49. Internet :Difference Between Flexible and Rigid Pavement, <https://engineeringdiscoveries.com/2019/02/26/difference-between-flexible-and-rigid-pavement/>(2019)
50. Internet: globalsecurity.org, "chapter 5 subgrdes and base courses", <https://www.globalsecurity.org/military/library/policy/army/fm/5-430-00-1/CH5.htm/> (2019).
51. Internet: <https://www.maininfrastructure.com/blog/seasonal-changes-asphalt/> (2018).
52. Internet: Salt doesn't melt ice – here's how it actually makes winter streets safe, "Julie Pollock Assistant Professor of Chemistry", <https://theconversation.com/salt-doesnt-melt-ice-heres-how-it-actually-makes-winter-streets-safe-110870/> (2018).
53. Erkens, S.; Porot, L; Glaser, R; Charles, J., "Aging of Bitumen and Asphalt Concrete Comparing State of the Practice and Ongoing Developments in the United States and Europe", *Delft University of Technology*, Netherlands, 20-26, (2016),

54. Erkens, S., Porot, L., Gläser, R., and Glover, C. J., “Aging of bitumen and asphalt concrete: Comparing state of the practice and ongoing developments in the United States and Europe”, *In Transportation research board 95th annual meeting. Transportation Research Board (TRB)*, USA, 12-17 (2016).
55. Internet : “Potholes”, <https://www.strathcona.ca/transportationroads/roads/potholes/> (2019)
56. Internet: Pavement Design, “Types of failures in flexible pavements and their causes and repair techniques by neenu arjun neenu is a civil and structural engineer and has experience in design of concrete and steel structures”, <https://theconstructor.org/transportation/types-failures-in-flexible-pavements-repair/16124/> (2019)
57. Internet: Flexible Pavement versus Rigid Pavement, “CSIR-Central Road Research Institute”, <https://www.nbmcw.com/tech-articles/roads-and-pavements/36977/> (2018)
58. Internet: basic types of concrete pavement,”Suryakanta”, <https://civilblog.org/2016/02/18/3-basic-types-of-concrete-pavement/> (2016).
59. Internet: “Myers Concrete”, <http://myersconcrete.com/roller-compacted-concrete/> (2016).
60. Internet: Roller Compacted Concrete transportation projects, “contact Cornelia (Sanders)”, <https://volkert.com/roller-compacted-concrete-is-it-in-your-toolbox/>(2016).
61. Internet: Pavement Design, “Types of Failures in Rigid Pavements and their Causes and Repair Techniques. Gopal Mishra Gopal Mishra is a Civil Engineer from NIT Calicut and has more than 10 years of experience in Civil Engineering and Construction”, <https://theconstructor.org/transportation/types-failures-in-rigid-pavements-causes-repair/16105/>(2017).
62. Internet: Types of Pavements, “Flexible Pavement / Rigid Pavement”, <https://www.aboutcivil.org/types-of-pavements.html/> (2018).
63. Internet: “Rigid versus Flexible Pavement Design”, <https://www.roanderson.com/2011/12/22/rigid-versus-flexible-pavement-design/>(2019).
64. Internet: Role of Concrete Road Infrastructure, “UltraTech Cement Ltd.’, <https://www.nbmcw.com/tech-articles/roads-and-pavements/40160-role-of-concrete-in-road-infrastructure.html/> (2019).
65. Internet: “PCC Joint Construction”, <https://pavementinteractive.org/reference-desk/construction/placement/pcc-joint-construction/>(2017).
66. Dale, H., Gary W. Fick, “Guide to Concrete Overlays: Sustainable Solutions for Resurfacing and Rehabilitating Existing Pavements”, *National Concrete Pavement Technology Center*. Netherlands, 30-36, (2008).

67. Harrington, D. S. "Guide to concrete overlays: Sustainable solutions for resurfacing and rehabilitation existing pavements", *National Concrete Pavement Technology Center*, USA, New York, 20-29 (2008).
68. Khaled, K., Shiva, R. and Krishna, S., "Utilization of Wyoming Bottom Ashin Asphalt Mixes Department of Civil and Architectural Engineering" *University of Wyoming*", USA, 15-21 (2006).
69. Ksaibati, K., and Sayiri, S. R. K., "Utilization of Wyoming bottom ash in asphalt mixes", *Mountain-Plains Consortium*, France Paris, 9-12 (2006).
70. Internet: "Laboratory wheel tracking devices", <https://pavementinteractive.org/reference-desk/testing/asphalt-tests/laboratory-wheel-tracking-devices/> (2019).
71. Internet: "Jointed Reinforced Concrete Pavement", <https://pavementinteractive.org/reference-desk/pavement-types-and-history/pavement-types/jointed-reinforced-concrete-pavement/>(2017).
72. Internet: "chapter 9, "paving operations", http://www.state.in.us/indot/files/Chapter9_pccp.pdf/ (2017).
73. Guide for Design and Construction of New Jointed Plain Concrete Pavements (JPCPs), "division of design office of Pavement Design Pavement Design & Analysis Branch", <http://www.windfarmbop.com/wp-content/uploads/2012/05/JPCP-Design-Construction-Guide.pdf/> (2017).
74. Internet: University of Florida. "Asphalt paving", http://damontallen.github.io/Construction-materials/Asphalt_slides.html /(2019)
75. Özbilgin, S., "Rijit ve Esnek Üstyapi Havaalaninin Teknik ve Ekonomik Bakımdan Karşılaştırılması", Yüksek Lisans Tezi, *İstanbul Teknik Üniversitesi Fen Bilimleri Enstitüsü*, İstanbul, 91-93 (2010).
76. İnternet: South African National Roads Agency Soc. Ltd., "Rijit ve Esnek Üstyapılarda Meydana Gelen Yük Dağılımları", https://www.nra.co.za/live/content.php?Item_ID=65 /(2017).
77. Yörükoğulları, E., "Doğal Zeolitlerin Karayollarında Buz/Kar Çözücü Olarak Kullanımı" *Madencilik bülteni inceleme*, Eskişehir, 40-42 (2005).
78. . Çimento, Cam, Seramik ve Toprak Ürünleri İhracatçıları Birliği, "*Dünya Çimento Üretimi ve Tüketimine İlişkin Genel Değerlendirme Araştırma Notları*", Ankara, 2-6 (2014).
79. THBB Beton Yollar Teknik Çalışma Grubu, "Beton Yollar", *Türkiye Mühendislik Haberleri*, Ankara, 38-44 (2003).
80. Türkiye Çimento Müstahsilleri Birliği, "*SSB Yollar Tasarım Rehberi*", Ankara, 8-20 (2018).

81. Internet: “Hamilton”, <https://www.youtube.com/watch?v=irxXqwyDqT8&list=WL&index=5&t=0s/> (2016).
82. Lay, M. G., “Handbook of road technology”, *CRC Press*, USA, Texas, 12-17, (2009).
83. Internet: “Technical Data sheet”, *www.baumerk.com Bitumen Rubber Based, Hot Applied, Joint Filler Technical Data Sheet. Baumerk Yapı ve Kimya San. Tic. Ltd. Şti/* (2017).
84. Andriolo, R., F., “The Use of Roller Compacted Concrete”, *Past-Press*, Brazil, 554-555 (1998).
85. Iowe Eyalet Üniversitesi, “Silindirle Sıkıştırılmış Beton Yol Kaplamaları İçin Rehber”, *Akpınar*, Trabzon, 7-9 (2010).



RESUME

Ibrahim abobaker alkasah was born in Msallata in 1984 and he graduated first and elementary education in Alzyani. He completed high school education in Alqizani High School, after that, he started undergraduate program in The Faculty of Technical Engineering -Libya Department of Constructions Engineering in 2005.

Then from 2005 -2007, he worked in a consulting office, he did engineering design and supervised several projects in Libya

Then in 2007-2008 he worked in the new Tripoli International Airport project with the French company" APAV for quality control".

From 2009 to 2010, he started working in Savings Company for Real Estate Investments as a civil engineer and supervisor of several real estate projects.

Currently, he works in the Savings and Real Estate Investment Bank as a civil engineer and a follower of several real estate projects of the bank since 2010.

To complete M. Sc. education, he moved to Karabük University in 2017.

CONTACT INFORMATION

Address: Karabük University
Graduate School of Civil Engineering
Demir-Çelik Campus/KARABUK

E-mail: Ibalkasah@gmail.com ; Ib_alkasah@yahoo.com

Phone: **009054547267608 - 002186154276**