

**UNIVERSITY OF GAZIANTEP  
GRADUATE SCHOOL OF  
NATURAL & APPLIED SCIENCES**

**INTELLIGENT COORDINATED CONTROL OF UNIFIED  
POWER FLOW CONTROLLER AND POWER SYSTEM  
STABILIZER TO DAMP INTER-AREA OSCILLATIONS IN  
MULTI-MACHINE POWER SYSTEMS**

**M.Sc. THESIS  
IN  
ELECTRICAL AND ELECTRONICS ENGINEERING**

**BY  
ALI DAHHAM ABDULAZEEZ  
SEPTEMBER 2015**

**Intelligent Coordinated Control of Unified Power Flow Controller  
and Power System Stabilizer to Damp Inter-Area Oscillations in  
Multi-Machine Power Systems**

**M.Sc. Thesis  
in  
Electrical and Electronics Engineering  
University of Gaziantep**

**Supervisor  
Assist. Prof. Dr. A. Mete VURAL**

**By  
Ali Dahham ABDULAZEEZ  
September 2015**

© 2015 [Ali Dahham ABDULAZEEZ]

REPUBLIC OF TURKEY  
UNIVERSITY OF GAZIANTEP  
GRADUATE SCHOOL OF NATURAL & APPLIED SCIENCES  
ELECTRICAL AND ELECTRONIC ENGINEERING DEPARTMENT

Name of the Thesis: Intelligent Coordinated Control of Unified Power Flow Controller and Power System Stabilizer to Damp Inter-Area Oscillations in Multi-Machine Power Systems.

Name of the student: Ali Dahham ABDULAZEEZ

Exam date: September 8, 2015

Approval of the Graduate School of Natural and Applied Sciences

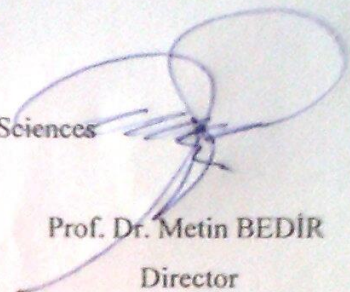
  
Prof. Dr. Metin BEDİR  
Director

I certify that this thesis satisfies all the requirements as a thesis for the degree of Master of Science.

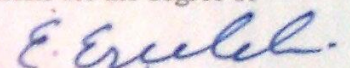
  
Prof. Dr. Ergun ERÇELEBİ  
Head of Department

This is to certify that we have read this thesis and that in our opinion, it is fully adequate, in scope and quality, as a thesis for the degree of Master of Science.

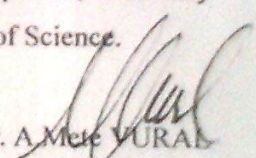
  
Assist. Prof. Dr. A. Mete VURAL  
Supervisor

Examining Committee Members

Prof. Dr. Ergun ERÇELEBİ



Assoc. Prof. Dr. Nuran DOĞRU

Assoc. Prof. Dr. Uğur Cem HASAR

Assist. Prof. Dr. Hacı TAŞMAZ

Assist. Prof. Dr. A. Mete VURAL

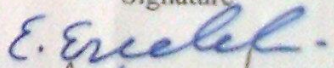
Signature

**I hereby declare that all information in this document has been obtained and presented in accordance with academic rules and ethical conduct. I also declare that, as required by these rules and conduct, I have fully cited and referenced all material and results that are not original to this work.**

**Ali Dahham ABDULAZEEZ**

**ABSTRACT**

**INTELLIGENT COORDINATED CONTROL OF UNIFIED POWER  
FLOW CONTROLLER AND POWER SYSTEM STABILIZER TO  
DAMP INTER-AREA OSCILLATIONS IN MULTI-MACHINE POWER  
SYSTEMS**

ABDULAZEEZ, Ali Dahham

M.Sc. in Electrical-Electronics Engineering

Supervisor: Assist. Prof. Dr. A. Mete VURAL

September 2015, 74 Pages

The aim of this thesis is to study the coordinated design of the unified power flow controller (UPFC) and two power system stabilizers (PSS) in a multi-machine power system using particle swarm optimization technique. To accomplish this task, the coordinated controller design problem has been formulated as an optimization problem that consists of an objective function and constraint equations. The effectiveness of the proposed design has been tested through time-domain simulations under different operating conditions in a multi-machine power system. It has been shown that without coordination, even if both PSSs and UPFC operates satisfactorily in a separate manner, an adverse effect or a negative interaction between controllers negatively affects power system transient stability. However, with coordinated design, the inter-area oscillations have been effectively damped.

**Key words:** Power system stabilizer, PSS, unified power flow controller, UPFC, inter-area oscillation, transient stability, particle swarm optimization

## ÖZET

### ÇOKLU MAKİNALI GÜÇ SİSTEMLERİNDEKİ BÖLGELER-ARASI SALINIMLARI SÖNÜMLENDİRMEK İÇİN BÜTÜNLEŞİK GÜÇ AKIŞ DENETLEYİCİSİ İLE GÜÇ SİSTEMİ STABİLİZATÖRÜNÜN AKILLI KOORDİNELİ DENETİMİ

ABDULAZEEZ, Ali Dahham

Yüksek Lisans Tezi: Elektrik-Elektronik Mühendisliği

Tez Yöneticisi: Y. Doç. Dr. A. Mete VURAL

Eylül 2015, 74 sayfa

Bu tezin amacı, bir çoklu-makinalı güç sisteminde, bütünleşik güç akış denetleyicisi ile iki adet güç sistemi stabilizatörünün parçacık sürü optimizasyonu tekniğini kullanarak koordineli tasarımlarını yapmaktır. Bu görevi başarmak için, koordineli denetleyici tasarım problemi bir hedef fonksiyonu ve kısıt eşitliklerinden oluşan bir optimizasyon problemi olarak formüle edilmiştir. Amaçlanan tasarımın etkinliği, bir çoklu-makina güç sisteminde farklı işletim koşulları altında zaman-domaini tabanlı benzetim çalışmalarıyla test edilmiştir. PSS'ler ve UPFC tek başlarına tatminkar olarak çalışmalarına karşın, koordinasyon olmadan, aralarında oluşan ters veya negatif bir etkileşim güç sisteminin geçici rejimini negatif bir şekilde etkilemektedir. Fakat koordineli tasarım ile bölgeler-arası salınımlar etkin bir biçimde bastırılmıştır.

**AnahtarKelimeler:** Güç sistemi stabilizatörü, PSS, bütünleşik güç akış denetleyicisi, UPFC, bölgeler-arası salınım, geçici rejim kararlılığı, parçacık sürü optimizasyonu.

*Dedicated to*  
*“To my dear wife and my kids”*



## **ACKNOWLEDGEMENTS**

I acknowledge with deep gratitude and appreciation to my supervisor Assist. Prof. Dr. A. Mete VURAL's guidance, excellent advice, and cooperation during the course of this work. He has followed my work step by step. Thus, I am extremely grateful and indebted to him for his expert extended to me. His timely and efficient contribution helped me shape this thesis into its final form. I extend my sincerest thanks to the Iraqi government.

## TABLE OF CONTENTS

	<b>Page</b>
<b>ABSTRACT</b> .....	<b>v</b>
<b>ÖZET</b> .....	<b>vi</b>
<b>ACKNOWLEDGMENTS</b> .....	<b>viii</b>
<b>TABLE OF CONTENTS</b> .....	<b>ix</b>
<b>LIST OF FIGURES</b> .....	<b>xii</b>
<b>LIST OF TABLES</b> .....	<b>xiv</b>
<b>LIST OF SYMBOLS / ABBREVIATIONS</b> .....	<b>xv</b>
<b>CHAPTER 1: INTRODUCTION</b> .....	<b>1</b>
1.1 Introduction .....	1
1.2 Motivative Of The Thesis.....	2
1.3 Objective Of The Thesis.....	3
1.4 Contribution Of The Thesis .....	4
1.5 General Outline Of The Thesis .....	4
<b>CHAPTER 2: LITERATURE SURVEY</b> .....	<b>5</b>
2.1 Introduction .....	5
2.2 Related Work In The Literature .....	5
2.3 Place Of Work In The Literature.....	9
<b>CHAPTER 3: POWER SYSTEM STABILITY AND INTER-AREA OSCILLATIONS IN POWER SYSTEMS</b> .....	<b>10</b>
3.1 Power System Stability .....	10
3.1.1 Introduction to Power System Stability .....	10
3.1.2 Rotor Angle Stability .....	11
3.2 Inter Area Oscillations.....	17
3.2.1 The Characteristics of Inter-Area Oscillations .....	18

3.2.2 Damping of Inter-Area Oscillations .....	19
<b>CHAPTER 4: UNIFIED POWER FLOW CONTROLLER AND POWER SYSTEM STABILIZER.....</b>	<b>21</b>
4.1 Unified Power Flow Controller .....	21
4.1.1 General Information about Unified Power Flow Controller (UPFC).....	21
4.1.2 Operating Principle of UPFC.....	22
4.1.3 Control Systems and Control Strategy for UPFC.....	25
4.1.4 UPFC Modeling .....	26
4.1.5 Principle Operation under Line Fault Condition .....	29
4.2 Power System Stabilizer.....	29
4.2.1 General Information about Power System Stabilizer (PSS) .....	29
4.2.2 Operating Principle of PSS .....	31
4.2.3 Different PSS Actions .....	33
4.2.4 PSS Transfer Function.....	34
4.2.5 PSS and the Exciter .....	34
4.3 Power System Damping Equipments .....	35
4.3.1 UNITROL stand-alone PSS .....	35
4.3.2 The EM Test OCS 500N6F Damped Oscillatory Wave.....	36
4.3.3 Simulator EM-Test OCS 500N6F For Fast & Slow .....	37
<b>CHAPTER 5: COORDINATION OF UNIFIED POWER FLOW CONTROLLER AND TWO POWER SYSTEM STABILIZERS.....</b>	<b>38</b>
5.1 Introduction .....	38
5.2 Cordinated Design Of UPFC and PSS .....	39
5.3 Particle Swarm Optimaization.....	40
5.4 PSO Iteration .....	42
5.5 Integrating M-File With The Power System Simulink Model.....	43
5.6 Parameters Constrains .....	43
<b>CHAPTER 6: SIMULATIONS STUDIES .....</b>	<b>46</b>

6.1 Sistem Model.....	46
6.2 Simulation Studies.....	48
6.2.1 Case study 1 .....	48
6.2.2 Case study 2.....	52
6.2.3 Case study 3.....	56
6.2.4 Case study 4.....	60
<b>CHAPTER 7: CONCLUSION AND SUGGESTIONS</b>	
<b>FOR FUTURE WORK.....</b>	<b>64</b>
7.1 Conclusion .....	64
7.2 Suggestions For Future Work.....	65
<b>REFERENCES .....</b>	<b>66</b>
<b>APPENDIX .....</b>	<b>71</b>

## LIST OF FIGURES

	<b>Page</b>
Figure 3.1 Power system stability .....	11
Figure 3.2 Omit the rotor angle.....	12
Figure 3.3 Omit the small signal.....	15
Figure 3.4 Active power (red) and reactive power (green) .....	16
Figure 3.5 Generator speed .....	16
Figure 3.6 Active power (red) and reactive power (green).....	16
Figure 3.7 Generator speed .....	17
Figure 3.8 Generator speed .....	17
Figure 3.9 Typical example of inter-area oscillation .....	18
Figure 4.1 Principle configuration of an UPFC .....	23
Figure 4.2 UPFC with transmission line.....	23
Figure 4.3 Simplified block diagram of the series converter control system.....	26
Figure 4.4 Implementation by 2 back-to-back converters of voltage source.....	27
Figure 4.5 Coupled source model for UPFC .....	27
Figure 4.6 PSS structure.....	30
Figure 4.7 Torque analysis between PSS and AVR.....	31
Figure 4.8 Structure of power system stabilizer (PSS) .....	32
Figure 4.9 Output power and excitation value .....	33
Figure 4.10 Single-frequency PSS .....	34
Figure 4.11 Multi-input PSS .....	34
Figure 4.12 Transfer function of PSS .....	34
Figure 4.13 Block diagram of excitation system .....	34
Figure 4.14 Unitrol stand-alone PSS.....	36
Figure 4.15 Damped oscillatory wave .....	36
Figure 4.16 Simulator For Fast & Slow Damped .....	37
Figure 5.1 Movement of particles like birds .....	40
Figure 5.2 Flowchart of PSO .....	42
Figure 5.3 Decreasing the cost function with iteration .....	42

Figure 6.1 Simulation Model .....	47
Figure 6.2 The oscillations in real power under fault without multiple PSS .....	48
Figure 6.3 The oscillations in reactive power without multiple PSS .....	49
Figure 6.4 Speed deviation under fault of G#1 (blue), G#2 (green) (pu) .....	49
Figure 6.5 The voltage magnitude of bus 1 under fault without multiple PSS .....	50
Figure 6.6 The voltage magnitude of bus 4 under fault with multiple PSS .....	50
Figure 6.7 The voltage phase angle of bus 1 under fault without multiple PSS .....	51
Figure 6.8 The voltage phase angle of bus 4 under fault without multiple PSS .....	51
Figure 6.9 The oscillations in real power under fault with multiple PSS .....	52
Figure 6.10 The oscillations in reactive power under fault with multiple PSS .....	53
Figure 6.11 Speed deviation under fault of G#1 (blue), G#2 (green) (pu) .....	53
Figure 6.12 The voltage magnitude of bus 1 under fault with multiple PSS .....	54
Figure 6.13 The voltage magnitude of bus 4 under fault with multiple PSS .....	54
Figure 6.14 The voltage phase angle of bus 1 under fault with multiple PSS .....	55
Figure 6.15 The voltage phase angle of bus 4 under fault with multiple PSS .....	55
Figure 6.16 The oscillations in real power under fault with multiple PSS .....	56
Figure 6.17 The oscillations in reactive power under fault with multiple PSS .....	57
Figure 6.18 Speed deviation under fault of G#1 (blue), G#2 (green) (pu) .....	57
Figure 6.19 The voltage magnitude of bus 1 under fault with multiple PSS .....	58
Figure 6.20 The voltage magnitude of bus 4 under fault with multiple PSS .....	58
Figure 6.21 The voltage phase angle of bus 1 under fault with multiple PSS .....	59
Figure 6.22 The voltage phase angle of bus 4 under fault with multiple PSS .....	59
Figure 6.23 The oscillations in real power under fault with multiple PSS .....	60
Figure 6.24 The oscillations in reactive power under fault with multiple PSS .....	60
Figure 6.25 Speed deviation under fault of G#1 (blue), G#2 (green) (pu) .....	61
Figure 6.26 The voltage magnitude of bus 1 under fault with multiple PSS .....	61
Figure 6.27 The voltage magnitude of bus 4 under fault with multiple PSS .....	62
Figure 6.28 The voltage phase angle of bus 1 under fault with multiple PSS .....	62
Figure 6.29 The voltage phase angle of bus 4 under fault with multiple PSS .....	63

## LIST OF TABLES

	Page
Table1.The optimal parameters of controllers .....	45

## **LIST OF SYMBOLS / ABBREVIATIONS**

UPFC	Unified power flow controller
PSS	Power system stabilizer
PSO	Particle swarm optimization
FACTS	Flexible AC transmission system
ITAE	Integrated time absolute error
PA	Power acceleration
PE	Electric power
PM	Mechanical power
$K_p$	Proportional gain of real power
$K_i$	Integral gain of real power
$K$	Gain of PSS of area 1
$K_a$	Gain of PSS of area 2
$K_b$	Gain of PSS of UPFC controller
$T_1$	Time of lead compensator of area 1
$T_2$	Time of lead compensator of area 1
$T_3$	Time of lag compensator of area 1
$T_4$	Time of lead compensator of area 1
$T_{1a}$	Time of lead compensator of area 2
$T_{2a}$	Time of lead compensator of area 2
$T_{3a}$	Time of lag compensator of area 2
$T_{4a}$	Time of lag compensator of area 2



T1b	Time of lead compensator of UPFC controller
T2b	Time of lead compensator of UPFC controller
T3b	Time of lag compensator of UPFC controller
T4b	Time of lag compensator of UPFC controller
AVR	Automatic voltage regulator
G	Generator
STATCOM	Static synchronous compensator
SSSC	Static synchronous series compensator
VSI	Voltage series inverter
AC	Alternating current
DC	Direct current

# CHAPTER 1

## INTRODUCTION

### 1.1 Introduction

The need of electrical power has been increased in a rapid way, therefore, the request of complex power systems have been continuously increasing. Today, the power system was under a big stress load than ten years ago. This case causes a bad behavior of work and decrease the limits of transient stability. Additionally, the interconnections among distantly placed power system these days are a public practice that provides an increase in the oscillations in the range of 0.1-0.3 Hz. If these oscillations are not damped well and the result may cause an increase in oscillations magnitude until it achieves a stability black. The stability of the power system is one of the concerns operation of the power system. In the few decades ago, a new technique has been found to serve a function of damp the low frequency oscillations and it is called power system stabilizer PSS [4].

Today, the new advance technologies appear for trustworthy and power systems operation. To reach monetary success and the operation dependability, more well organized operation and surviving transmission control will become very clear that the substructure of the system are required. Recently, a better application of power system existing has been provided via using the development advance technologies of power electronic devices which are called FACTS controllers. These controllers have the ability to control the situations of the network in high accuracy and this characteristic of FACTS controller could be loaded to enhance the stability of voltage, power system transient stability and steady state stability [1].

Nowadays, PSS used with a generator excitation system where its function of PSS is to add appropriate damping signal to the generator excitation system to cope with parameter oscillations. The PSS input signal can be either the frequency difference

between the mechanical input power and the output electrical power of the generator. The output signal is used as an additional input to the excitation system which is proved to be effective in execution there allocated functions, on the other hand, PSSs offers an additional feedback signal, and they hurt a disadvantage of liable to make a big difference in the voltage. For activate professionally operation, the design of contemporary power systems is becoming robustness to supply the demand power to many load centers with a best dependability. Generation units are frequently placed, their positions to produce an economic situation to safety reasons and environmentally favorable. For carrying power by transmission lines from the generation units to loads, in a present day, a power systems have a high interconnected points for economical states. And the benefits of these points are: Sharing the reserves of generating units, abusing load variation and increasing economy via using the units with great effect without losing the reliability. Recently, the power request has been increased than before considerably, where the growth of a generation of the power and transmission lines stays in limited situations [2].

Power system electromechanical oscillations are a greater problem that has seen in power systems, and they are offering a challenge to electric and control engineers for many years. In a difficult state, these oscillations are very inadequately damped in some cases, and its effect causes a mechanical exhausting of the generation units and unwanted power differences through the transmission lines and increasing the load over the transmission lines. This case will allow the controllers to supply a best damp for these bother oscillations by using PSSs applications. These applications cannot offer a full damping for these oscillations like inter- area oscillation in multi-machine power systems.

FACTS devices can present the solutions of these cases, by using these controllers the operational flexibility is better for the power systems. Oscillations appear in the system due to the interaction of two different sets of generation units through transmission line or by the variation of loads.

## **1.2 Motivation of the Thesis**

The different connections can be possibly presented between the FACTS controllers and power system stability PSS [2]. The same case of connections has been categorized into variant ranges of frequency and different interaction problems

among FACTS and PSSs, the device which is called PSS is used to enhance damping electromechanical oscillations of the generator. This stabilizer has been working on big generators for many years to damp these oscillations. Because of defining the PSS applications, it is very important to introduce a common stability idea of power systems and the effects of disturbances on it. PSS becomes progressively general device in generation and transmission [1]. This thesis will discuss the first principle of PSS and also the main controller from FACTS devices which is called a unified power flow controller UPFC and their efficiency.

### **1.3 Objective of the Thesis**

The thesis deals with using of controlled active power, reactive power, bus voltage and speed deviation of multi-machine power systems at two locations in order to increase the damping of electro-mechanical oscillations. The importance is on using intelligent techniques like particle swarm optimization to coordinate multiple power system stabilizer and unified power flow controller. The main objective is to find the important limitations and possibilities of the resulting damping system, and to give insight into the complex power systems dynamics by giving explanations and interpretations.

The thesis aims to examine the oscillation damping by using coordinated design between the UPFC and multiple PSS to obtain improvement in the systems stability when added PSS to automatic voltage regulator AVR of generators. Therefore, 2PSS offers a superior cost performance. And with an abundant system line-up including analogue, digital and  $\Delta P, \Delta w$  and  $\Delta f$  input type model. For solving a problem of both controllers should be transferring these problems to an optimized problem. To get this goal, a new developed algorithm called particle swarm optimization PSO is used to examine the parameters of optimal controller. It can evaluate these present controllers on a multi-machine power system with infinite bus. The simulation of nonlinear time domain will show the efficiency of coordination between UPFC and 2PSS for damping these oscillations under fault in a fast way and robust style in order to get more stability for the power system.

In this thesis, the coordinated controller design for UPFC and 2PSS carry out using a new intelligent technique to optimize the problems. To do this, the coordinated design problem will be expressed as an optimization problem by reducing the

objective function. It is expected that the interactions among these main controllers will be improved. The effectiveness of the propose design will be tested through time domain simulations under fault, the effect of fault on the stability of power systems will also be tested.

#### **1.4 Contribution of the Thesis**

The coordinated design of UPFC and multi PSS has been executed using intelligent techniques particle swarm optimization. The poroblems of the controller has been furnilate to an optimization problem buy minimize the objective function of the controller in order to provide the required goal to add more stability to power system [4].

#### **1.5 General outline of the Thesis**

This thesis is organized into seven chapters:

**Chapter 1:** This chapter gives a simple detail of the work, including objective and the contribution of the thesis and the organization of the project.

**Chapter 2:** This chapter explains the literature related to the work and the place of this work in the literature.

**Chapter3:** This chapter discusses the power system stability and inter- area oscillations with some details.

**Chapter 4:** This chapter offers a general information about UPFC and PSS with details.

**Chapter 5:** This chapter explains how the coordination between UPFC and multiple PSS are made using and particle swarm optimization.

**Chapter 6:** This chapter represents the simulation studies and the discussion of the results.

**Chapter7:** This chapter contains the conclusion and suggestions for future work

## **CHAPTER 2**

### **LITERATURE SURVEY**

#### **2.1 Introduction**

Many researches have focused on damping of inter-area oscillation in the power system by utilizing different types of controllers. This chapter establishes a comprehensive, up to date literature survey.

#### **2.2 Related Work in the Literature**

A.R. Messenia (1999) used SVCs to aid damping oscillations low-frequency of inter-area in large power systems. He used modal analysis of a linearized model of the power system, and used an effective algorithm to calculate and detect oscillations of the power flow for every mode where developed before. Thus, to assess the influence of dynamic voltage support on system damping and to identify optimal locations for SVCs, the controllability and observability measures are used efficiently [5].

L. Fan (2002) proposed a method to categorize and in effect the local signal that has ability to use by a TCSC device to damp inter-area oscillations for many power system operating requirements. He developed two remainders based indices for this goal. The first one is to identify the most effective signal to feedback for different operating conditions, the second index is to manage to the interaction of the controller with other oscillation modes than the critical mode [6].

Stella Morris (2003) showed a Unified Power flow controller (UPFC) and its genetic algorithm fuzzy PI controller to enhance and upgrade the stability in the transient case to raise the performance of the -power system by using the lowest number procedures and created the proportional action which by 1-to-2 inference mapping which gives a variable gain of the PI controller [7].

W. Fang. (2003) proposed a method to coordinate UPFC with PSS in order to damp oscillations which caused by a disturbance of a small signal. This method begins to derive a mathematical model of UPFC, with its differential equations was integrated to find a control strategy for enhancing a stability of a small signal. The method used to classify the eigenvalue of the biggest portions and then minimize it as a nonlinear problem. In order to achieve the robustness of the control system [8].

Chun Liu. (2004) showed the PSS is so functioning controllers for enhancement the damping oscillations low-frequency, where this controller can increase the damping torque operation for inter area modes of extra signals which enter into the excitation controllers previously it achieved with generation units. Testing and determination the problems of poor damping oscillation. This technique is established on the single machine infinite bus models derived via coherency technique [9].

A.R. Messina. (2004) presented a methodology of frequency domain created on control theory were planned to coordinate a FACTS controllers and to minimize the adverse the communication between loops; First, dynamic loop contact in multiple-input multiple-output control systems are presented [10].

R. Castellanos B. (2006) examined the use and alteration of power system stabilizers (PSSs) to increase small-signal dynamic performance of the Mexican interconnected system (MIS). He determined that the sensitive system modes more manageable by obtainable PSSs and using the additional control activities to damp low-frequency oscillations of inter-area modes. The effects of small and large perturbations are presented to illustrate the placement and tuning of PSSs at several appropriate locations throughout the system [11].

M. Zarghami. (2008) found a way of applying a specific set of the global data for checking area oscillations of the power network via using the Unified Power Flow Controller. He used the algorithm to minimize the other viewers for estimating the information were missing, the function of a control is to determine all data in a wide area control approach were missing through frequency measurements [12].

V. Gohari Sadr. (2008) a new robust controller for Unified Power Flow Controller (UPFC) has been designed to damp local and inter-area oscillations. Optimization method based on Particle-Swarm Optimization (PSO) Algorithm is presented to

optimize the constraints of a fuzzy PI controller of a UPFC in order to enhance the stability of the transient case of the power system [13].

H. Shayeghi. (2009) approached and investigate choosing problem of the UPFC finest input signal and build the best UPFC created damping controller because of developed the damping oscillations of the power system. This controller is adjusted to promptly shift the un-damped modes to a recommended region in the s-plane. The problem of robustly UPFC controller is expressed as an optimization problem, the damping ratio of the electromechanical modes which solved via using a new method which called (PSO) method that has a hard competence to discovery the most optimistic outcomes. To get the guarantee of the strength of the strategy of damping controller, he designed procedure takes into reason a wide range of operating circumstances and system configurations [14].

N. Talebi. (2011) showed that the low Frequency Oscillations (LFO) take place in power systems because of absence of the damping torque in order to control power system coordination, Power System Stabilizer (PSS) was used to damp LFO. Unified Power Flow Controller (UPFC) is a famous controller from FACTS devices, it can control power flow, decrease sub-synchronous resonance and growth stability of transient case. So, UPFC may be used to damp LFO instead of PSS. UPFC damps LFO through direct control of voltage and power [15].

J. P. Therattil. (2011) represented the way to damp out inter area oscillation of a multi machine power system via UPFC. The Generators in a power system should include a changing in continuous load in its daily procedure, and these acute changes can occur when there is a fault in the power system. Because of the nonlinear controllers are free to functioning point, this controller can give better outcomes than the linear controller [16].

X.Y. Bian. (2012) showed an application of a probabilistic theory to the coordinated design of power system stabilizers (PSSs) and FACTS devices, via taking (SVC) as a controller to enhance the oscillation damping in multi machine over a large set of working situations. Predictable analysis of eigenvalue of the probabilistic environment. In which the statistical nature of eigenvalues corresponding to different operating circumstances is labelled by their prospects and alterations. Probabilistic sensitivity indices (PSIs) are used for strong damping controller site selection and for



optimization objective functions. A probabilistic eigenvalue-based objective function is employed for coordinated design of probabilistic eigenvalue-based objective function is employed for coordinated design of PSS and SVC controller parameters [17].

M. R. Esmailia. (2012) Modified a new technique which used for transferring the problems to optimization problems by particle swarm optimization (MPSO) and she offered and applying an immediate design of coordinate both controllers (UPFC) and (PSS) to damping oscillations in multi- machine power system. For calculation of the effectiveness and durability of the planned controllers. As a result, she showed that the presented coordinates have the ability to damp inter area fluctuations and improving the stability of the power [18].

R. Narne. (2012) presented the coordination control tuning of PSS with FACTS devices. He employed a genetic algorithm to enhance the damping of power system inter area oscillations. The Thyristor controlled series compensator (TCSC) and the static synchronous compensator (STATCOM) founded by controllers are coordinated. The power system employed with PSS, STATCOM and TCSC [19].

L. H. Hassan (2013) used a Genetic Algorithm (GA) to execute a new coordinated design between Power System Stabilizers (PSSs) and Unified Power Flow Controller (UPFC). The GA detects the position for the UPFC by detecting its parameters, and optimization of the quantity of parameters and sites of PSSs underneath multi conditions [20].

M. R. Esmailia. (2013) established the coordinated parameters of PSS and SVC. By design a problem at first and converting to an optimization problem, and finally, solving it via a new algorithm which called PSO [21].

L. H. Hassan. (2014) definitely a technique to govern the optimal sites and the number of (PSSs) of multi-machine via genetic algorithm (GA) and participation factor (PF). The PF technique is mainly used to estimate and to identify the sites of the power system stabilizer, on the other hand, the GA is used for additional minimize the number of PSSs, this will effect of the results in the optimization of the limits of both controller and their positions under different conditions [22].

### **2.3 Place of Work in the Literature**

This work presents a method which can be used to damp inter area oscillations by coordinating the multiple PSS and UPFC in order to enhance stability of power systems using a new optimization technique, particle swarm optimization, to deal with the multi-controllers parameter tuning.

## **CHAPTER 3**

### **POWER SYSTEM STABILITY AND INTER-AREA OSCILLATIONS IN POWER SYSTEMS**

#### **3.1 Power System Stability**

##### **3.1.1 Introduction to Power System Stability**

The ability of the power system to still at the equilibrium point under an initial condition of operation is defined the stability of electric power system after a physical disturbance [24]. The stability of power system demonstrates the capability of the electrical power system in case of operation of a given initial to restore the state of the operating balance after suffering a physical disturbance with all variables of a system is bounded, so, it is maintaining the safety of the system, and it is maintained in practice, the complete power system intact remnant without any faltering to back from loads or generators to balance the condition of stability between opposing forces [24].

In order to get the continue power under all conditions, especially in modern cities because of the large requirement of electricity and power, this case leading to increase the needing for electricity. This need is very important to work at limit level of power system by keeping the stability in balance case in both quality and reliability of this power, also this increasing of requiring power depends the sensitive industries of electric power such as, technology information, electronics and communications. In this case, this will put a big challenge of engineers and also a big responsibility to provide and deliver this power to consumers were needed the power which has the characteristics of stable and quality, in this chapter we will try to understand how to evaluate the stability of power system [43].

Instability occurs when the disturbing acts as a disruption in the ongoing balance between opposing forces. When a transient disturbance appears, if the power system stays in stable state, the power system reaches a new state of equilibrium.

Furthermore, instability occurs, these can be lead to running away. For example; a steady state increase in gradual weakening in bus voltage or divided the angle of the generator rotor. It could result in an unstable system conditions to outage cascading and the tripping of a large part of the power system grouping in the stability of the power system.

The classification of power system stability is shown in Figure. 3.1 be considering disturbance size and time period.

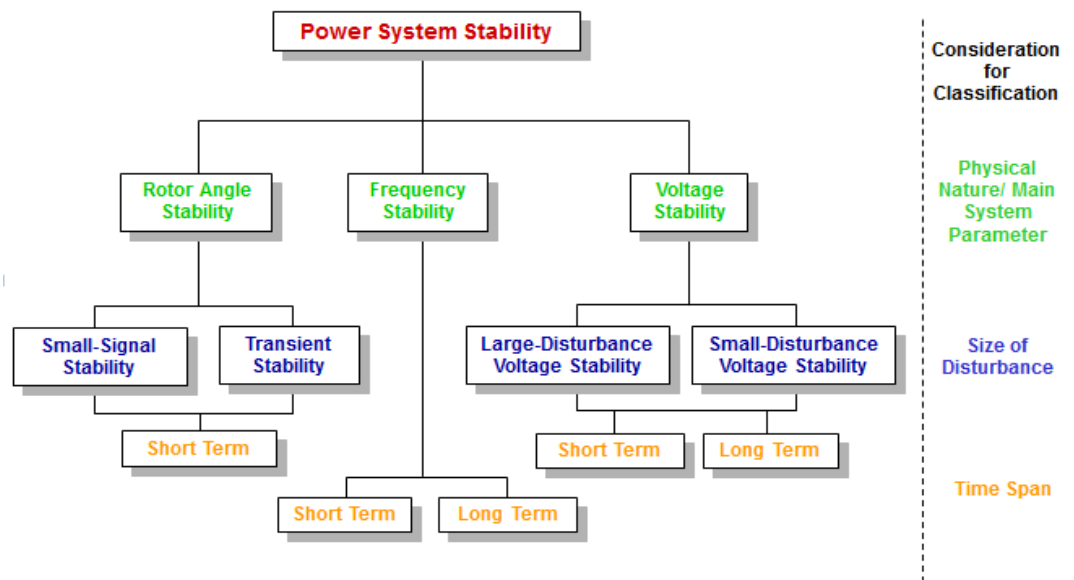

Figure 3.1 Power system stability[53]

The Figure 3.1 shows the structure of power system stability where it classifies in three branches: rotor angle stability, frequency stability and voltage stability. Rotor angle stability divided into two short term parts; small signal stability and transient stability. Voltage stability contains both long and short term related to large-disturbance voltage stability and small disturbance voltage stability. Whereas the frequency stability has both time spans short and long terms.

### 3.1.2 Rotor Angle Stability

Rotor angle stability refers to the capability of synchronous machines in a power system to stay in synchronism after disturbance occurs. This stability is contingent on the ability to remain in balance between mechanical torque and the electromagnetic

torque of each generation unit in the system. The instability may occur as a result of increasing the swings of several generating units and may lead to damage to the generating units. Any alteration in electromagnetic torque  $\Delta T_e$  of a generator will result a problem that may be determined in two components:

- The component of synchronizing torque that in phase with angular deviation of the rotor  $\Delta\delta$ .
- The component of damping torque that in phase with deviation of the speed  $\Delta\omega$  and is formulated as an equation written below [23].

$$\Delta T_e = \Delta T_s \Delta\delta + T_D \Delta\omega \quad (3.1)$$

Where  $T_s \Delta\delta$  is the component of changing synchronizing torque,  $T_s$  is the coefficient of synchronizing torque,  $T_D \Delta\omega$  is the component of changing the damping torque and  $T_D$  is the coefficient of damping torque. The stability of the system can be subject to the existence of these two components of torque for each generation unit. Figure 3.2. Absence of adequate synchronizing torque effect an increase in the angle of the rotor over an aperiodic mode. This instability form is called a non-oscillatory instability. Losing the damping torque will increase the amplitude of rotor oscillations, this instability form is called an oscillatory instability and the stability of rotor angle can be categorized into two forms [23].

- Stability of small disturbance rotor angle
- Stability of large disturbance rotor angle.

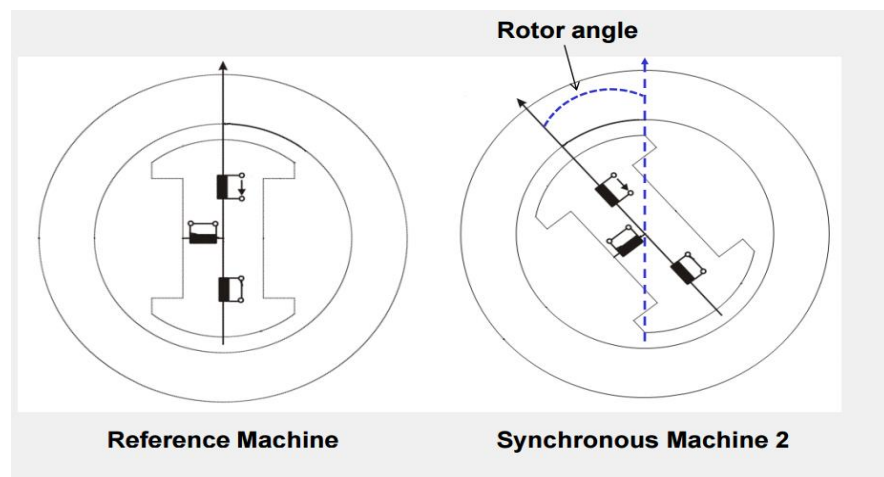

Figure 3.2 Omit The rotor angle [52]

- **Stability of Small Disturbance Rotor Angle**

The stability of small disturbance rotor angle means that the system remains in synchronism under small disturbances, when this disturbance is small enough, it can be considered that the behavior of nonlinear system approximated like the linear system. The effect of small disturbances may make a small change in load and can be seen as a tripping of small generators, tripping off line and switching on or off of small loads. Two types of instability can be shown due to small disturbances: non-oscillatory instability, where the rotor angle is kept on rising state due to a small disturbance and oscillatory instability, where the rotor angle oscillates with rising the magnitude [43].

The instability of small disturbance rotor angle is fearful with the capability of the power system to staying in the synchronizing state of a minor disturbance. These disturbances are deliberated to be adequately small, and the usage of tools of powerful analysis of linear systems will allow to give assistance of stability of rotor angle small disturbance is frequently related to damping the oscillations. In nature, these problems can be either local or not. The explanations of these problems can be given as shown:

- 1- The problems of local mode include a small portion of the power system and these problems are frequently related with oscillation of rotor angle of the generator. Such oscillation which named an oscillation of local mode. Because of these oscillations are limited to a small area at one generation unit, the term local is used efficiently, so, damping these oscillations is subject to the strong point of the transmission system where it can be shown by the power plant in the control system excitation of generation unit and the output of the plant [23].
- 2- The problems presented in the power system are caused by an interface between a big set of generation units known a global problem. These problems are related to the oscillations of rotor angle of a set of generation units in one area where against another generator unit group in another area.

- **Stability of Large Disturbance Rotor Angle**

The stability of large disturbance rotor angle means the system remains in synchronism under large disturbances. The large disturbances can be switched on or off of the large loads, fault and tripping of a large generating units. In case of subjecting the power system to large disturbances will lead to a big trip in the rotor angle of the generator. This problem will appear when changing a large rotor angle. And it leads to failing in power system to be a linear system like the stability of small disturbance. Time domain of angle stability in a large and small disturbances between 0.1-10 second. Because of this reason, both large and small disturbances is a short term phenomenon [43].

With the capability of the power system to keep the synchronism when exposed to a simple disturbance, the stability or the transient stability, a big disturbance rotor angle is distressed, like a transmission line short circuit. Transient stability state depends on the severity of the disturbance and the initial operating case of the system, on the other hand, in a big power systems, instability transient state may not often appear as a main swing instability related to a single mode, it might be a consequence of the superposition swing mode of a slow inter-area and a swing mode of a local plant will cause a great trip of rotor angle elsewhere the first swing [23].

The capability of synchronous interconnected of machines which stay in synchronizing after becoming trip, and be contingent on the capability to restore the balance in the middle of the mechanical torque of synchronous machine and electromagnetic torque, when disturbed occur, the generators may become unstable, the result of running away situation is due to the imbalance torque. An essential to an output power of synchronous machines differs from the angle swing of the rotor, the instability result may appear as a growing of angles swings of several generation units, that's may lead to loss the synchronizing with further generators [27].

The term is commonly used to denote the stability angle wide disturbance, and the ability to maintain the synchronism of the power system, when exposed to a simple transient disturbance as shown in Figures 3.4 through 3.8 Which influenced by power angle (nonlinear). The stability is contingent on the condition of the severity of the disturbance and an initial operating, a big difference of disturbances can

appear on the system, on the other hand, design and operate in order to be stable for a chosen set of emergency state of transmission faults.

- Small signal (Angle) Stability

Oscillatory stability is the power system's ability to stay under small disturbances in a synchronism state. The particular concern of oscillatory phenomena is: Control mode, Inter area modes, Local modes and Analysis of Torsional modes using a model / eigenvalue analysis as shown in Figure 3.3.

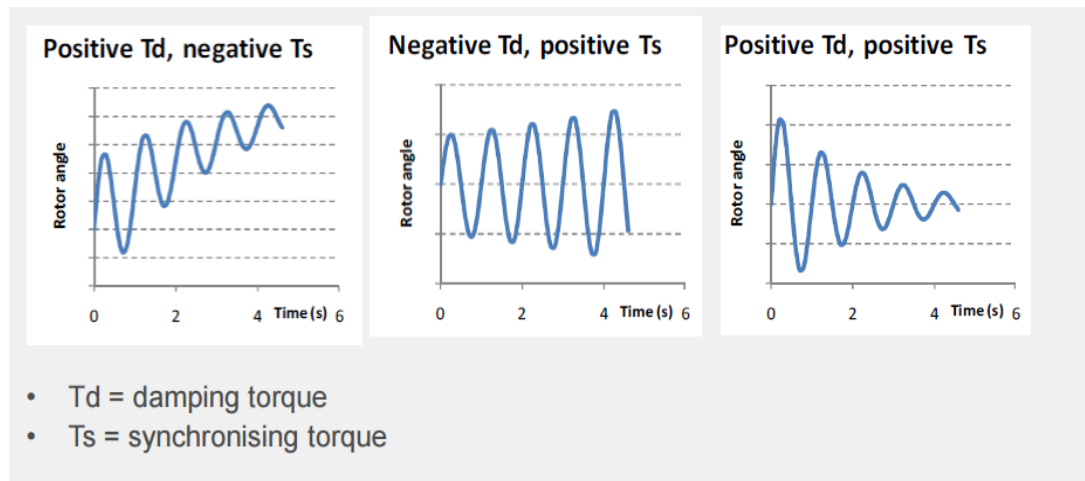

Figure 3.3 Omit the small signal [52]

Small perturbation or (small signal) stability, is the capability of power system to uphold the synchronism underneath tiny disturbances, disturbances adequately small, if linearization system equations are allowable for analysis. Two forms of instability that may occur: increasing aperiodic in rotor angle because of the adequate synchronizing torque and the oscillations of the rotor of a growing the amplitude due to dearth of adequate the damping torque. Recently, SSS problems, feasible power system are always related to oscillatory modes: inter area oscillation modes 0.1-0.8 Hz. And the local plant oscillation mode 0.8-2.0 Hz. As shown in Figure. 3.4.



- **Transient Stability: stable case**

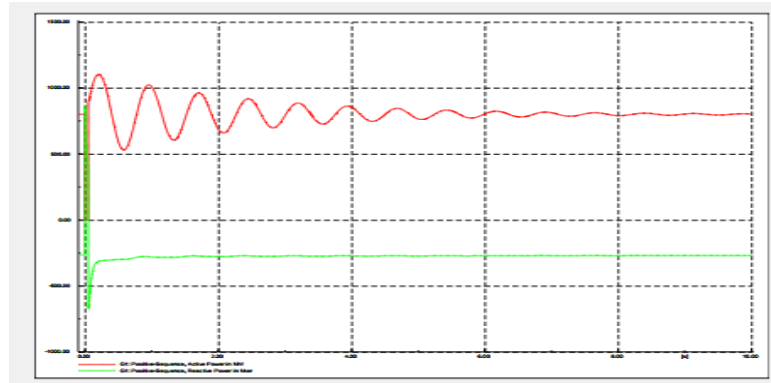

Figure 3.3 Active power (red) and reactive power (green) [52]

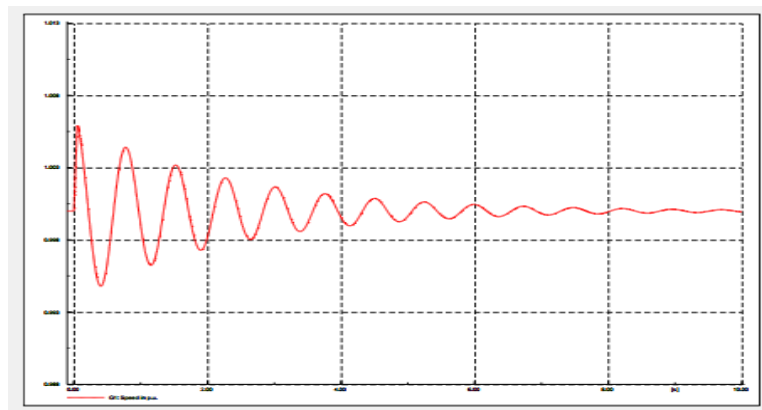

Figure 3.4 Generator speed [52]

- **Transient Stability: Critical case**

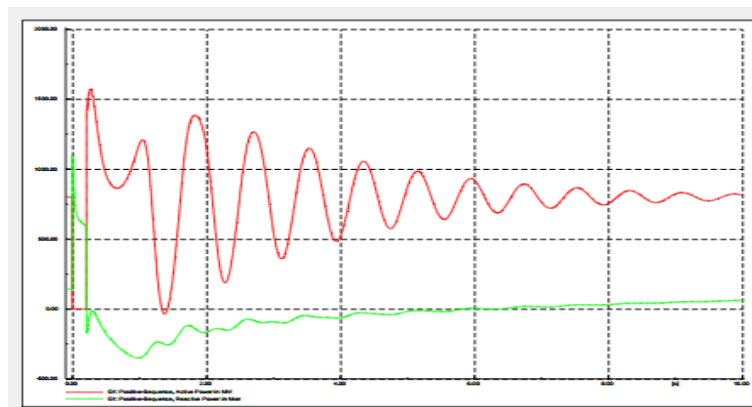

Figure 3.5 Active power (red) and reactive power (green) [52]

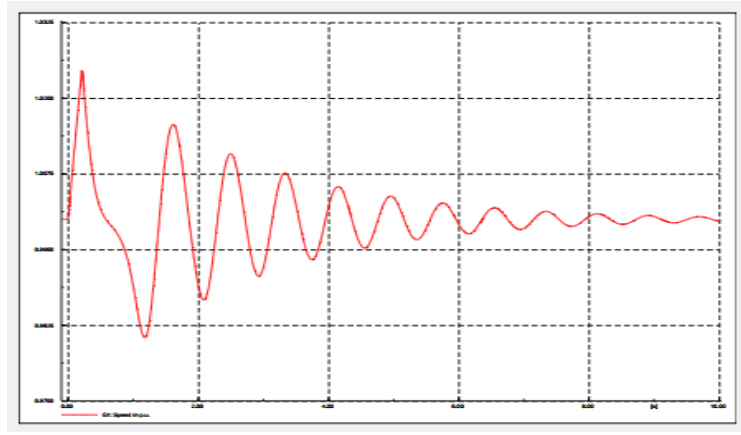

Figure 3.6 Generator speed [52]

- **Transient Stability: Unstable case**

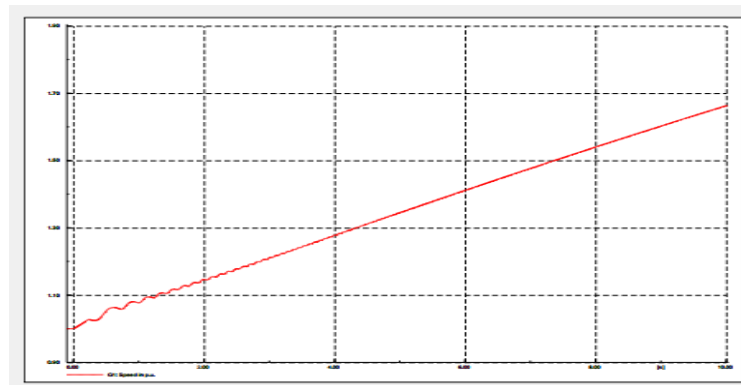

Figure 3.8 Generator speed [52]

### 3.2 Inter Area Oscillations

Inter-area oscillations are low frequency parameter swinging of one group of generators against another group of generators located in a large geographical region, which are tied by long and weak transmission corridors. This kind of oscillations generally induces electromechanical oscillations, which can result from small or large disturbances, such as a change in the operating point of the interconnected-system or a line fault. Inter-area oscillations usually occur in the range of 0.1-1.0 Hz. The complexity of the interconnection, the existence of large and weak transmission corridors can lead to inter-area oscillations. Such an inter-area oscillation of real power is shown in Figure3.13. These oscillations are undesirable as they threaten system stability. If not damped effectively, they can cause partial or complete power interruptions. The non-linear and non-deterministic behaviors of the large interconnected systems make the damping control difficult. It is currently reported that to

recover a lightly damped system from inter-area modes is very challenging. The coordination between network operators of each area is highly required so as to tune the PSS parameters in real-time to take the damping action efficiently.

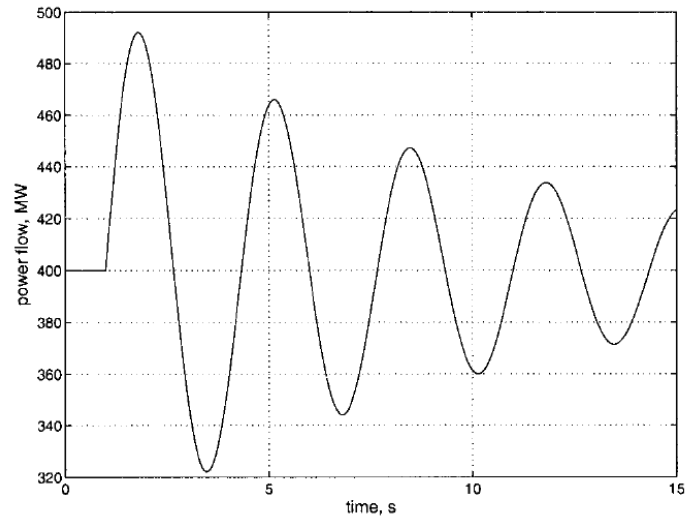

Figure 3.9 Typical example of inter-area oscillation [55]

### 3.2.1 The Characteristics of Inter-Area Oscillations

The interconnection between two generators or to plant in the power systems will create a big inter area oscillation are appearing. When a set of machines in one area against another area, where interaction by means of the transmission systems. A slight of disturbance may be making a changing in loads or it may appear as a result of a great disturbance.

Instability types such as a small rotor signal and the instability of angle in a nature interconnected by power system is usually controlled by low frequency inter area oscillations (LFIO). A small disturbance may be a result of LFIOs, in this case, the system will collapse because of the effects may not be instantly noticed, but, it will increase a voltage at a period of time. The properties of mode LFIO in the system are contingent on the arrangement of network, types of excitations of the systems of generator and the sites of these oscillations, where the characteristic of the load has a large effect on the stability of inter area modes [26]. On the other side, the inter area damping modes and the frequency are depended on the feebleness of ties of inter area and the power which transported through them.

### **3.2.2 Damping of Inter-Area Oscillations**

For an insulated excellent damp of oscillations of particular inter area modes. A PSS is proposed as an independent part for any modes attention of inter area. This controller uses only those input signals of local and remote signals, a single inter area mode is a greatest visible and situated at the generation units that has most efficient in this mode. A PSS local mode can be designed for a specific single inter area mode, besides, its actions in a main way of the band of frequency that achieved by the assigned mode natural frequency. PSS device is gotten created on the frequency response amplitude gain of the measurement that has best suited for inputs of all generators in the unified system. Choosing of a suitable local and remote extra input signal. Finally, the input signals depended on the observability degree of the reflected single mode.

The one form senior worries for reliable and secure process of a big power system is damping the oscillation. The power system was working under unnatural situations that's might be led to break up a case of the system or minimize the transferring of the power over dangerous path. There is an increasing interest in efficient control device to damp oscillation in the form of power system stability PSSs, the measurements can be used to control the input signals and to increase the oscillation damping, the most important ones being control of excitation over PSS and / or additional UPFC damping control, high voltage DC and other FACTS devices.

For the industrial movement and deregulation of the power in variable increasing of transferring the power over long distance, adding a new facility to transmission and making the oscillation of inter area to be soft damping [27]. Since last two decades, the engineers have begun to use the FACTS controller to damp the oscillations of the power system. Sometimes, FACTS devices are putting in the power system to voltage stability enhancement or to power flow control in order damping these oscillations. However, when connected, the additional control can be enhanced damping and satisfying the conditions of the device.

Power oscillation damping control can be used as well through PSS on excitation control system of generators. A PSSs are very useful and effective and usually used for local electromechanical oscillation damping, but in big power systems, the tune all PSS may be so difficult. The great power system is a nonlinear system

interconnected with many effect damped modes of oscillation. If the damping is small or negative, it can force the constraint operation of the system. Therefore, it is so important to have the stability to determine their nature, using controls to prevent their instability by finding stability limits in numerous cases. The electromechanical oscillation can be classified into two groups: Inter area oscillations group and local oscillation group [27].

The oscillations of inter area are spotted when a couple of machine groups of two areas will swing against each other in normally cases with a frequency below 1 Hz. The inter area modes studying that complicated were needed to detailed offers of the interconnected system and inter-area oscillation modes are affected by many states of a bigger area of the network. The local oscillations group is spotted when one plant swings against the system or many numbers of generators and its frequency between 1-2 Hz.

## **CHAPTER 4**

### **UNIFIED POWER FLOW CONTROLLER AND POWER SYSTEM STABILIZER**

#### **4.1 Unified Power Flow Controller**

##### **4.1.1 General Information about Unified Power Flow Controller (UPFC)**

The UPFC was first proposed by Gyugyi in 1991 [29]. It is the most versatile member of FACTS devices that can be used in optimization and control of power systems. The great potential application areas, especially at the transmission side, have been well-documented in the literature [29]. UPFC can control all system parameters instantly and independently, namely as, bus voltage, bus phase angle, and line impedance. With this respect, it is possible to control real and reactive power flows on the transmission lines as well as a selected bus voltage magnitude, simultaneously. The generic representation of UPFC is shown in Figure 4.1.

The UPFC consists of a series and a shunt converter with a common DC link, each of which is coupled to the system via coupling transformers. The shunt converter alone can be considered as a static synchronous compensator (STATCOM), while the series converter alone can be considered as a static synchronous series compensator (SSSC). With this respect, UPFC combines the functions of both STATCOM and SSSC, which makes it a powerful power system compensator. The function of the series converter is to inject a three-phase voltage with controllable magnitude and phase angle. The free parameter choice of the series converter should be compensated by the shunt converter. So the function of the shunt converter is to supply/absorb to/from the series one [30]. The reactive power can be generated/absorbed by the shunt converter itself, so there is no need to exchange reactive power. The real power balance between series and shunt converter yields a regulated voltage at the DC link.

The UPFC consist of parallel and series transformer, which are connected through two converters of voltage source with a common DC capacitor, interchange active power between parallel and series transformer to control the phase shift of the series voltage done by the DC circuit, this transformer offer a full controllability for power flow and voltage.

In order to get a high hard operation of the voltage source converter and the protection, the Thyristor Bridge with series converter needs to be protected. Because of UPFC is an expensive device, thus, it limits the practical applications with power flow and the voltage control.

#### **4.1.2 Operating Principle of UPFC**

UPFC controller consists from two source inverters (VSIs) with a common DC storage capacitor are connected to the power system via coupling of transformers. One of them is connected in parallel to the transmission system via a shunt transformer, while the other one is connected in series through a series transformer, this is the basic components of the UPFC as shown in Figure4.2.

It has the ability to control the series inverter to inject a symmetrical three phase voltage to control active and reactive power flow of the line. Thus, this inverter will exchange active and reactive power with the line, the reactive power is electronically provided by the series inverter and the shunt inverter operates in such a way to demand this power positive or negative from the line to keep the voltage across the storage capacitive VDC constant. Therefore, the losses of the transformers and their inverters is equal only to the pure real power absorbed from the line by the UPFC. To supply a voltage regulation at the connection point, it uses the remaining capacity of the parallel inverter to interchange reactive power with the line.

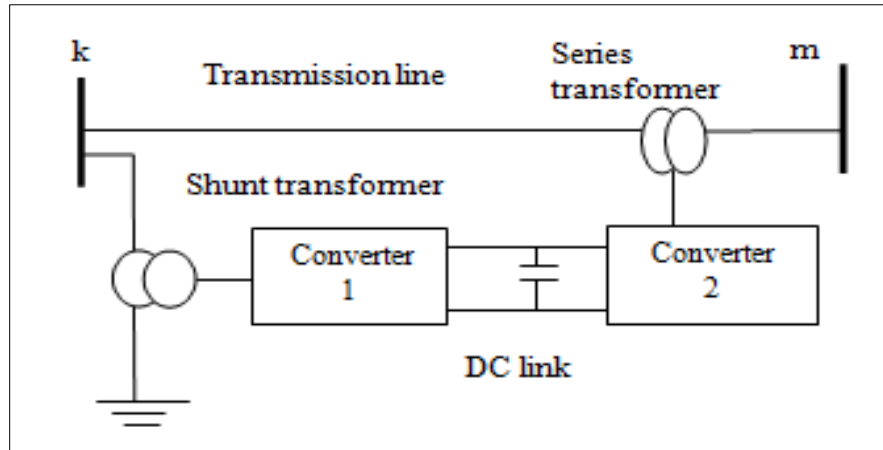

Figure 4.1 Principle configuration of an UPFC [39]

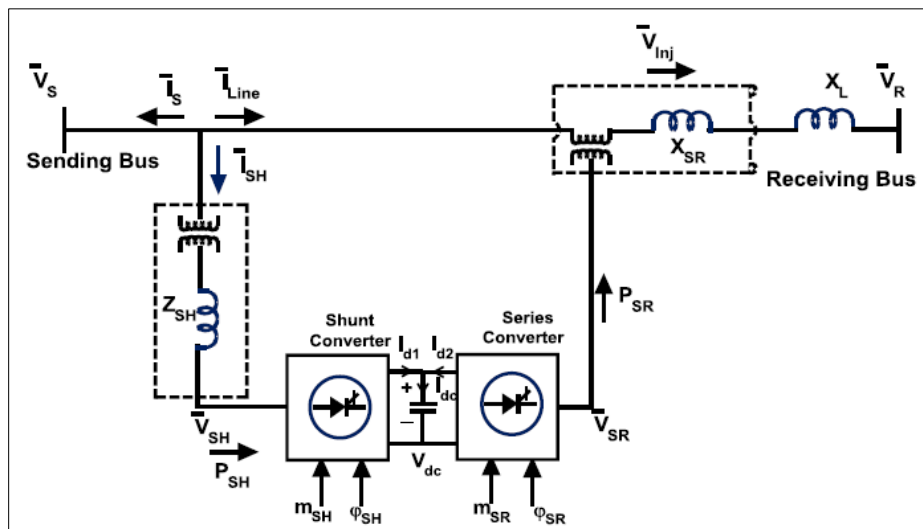

Figure 4.2 UPFC with transmission line [16]

By splitting up the DC side, two (VSIs) can work independently from each other. In that case, the parallel inverter operates as a STATCOM and will generate a reactive power to regulate and control the voltage magnitude at the connection point. On the other side, the series inverter operates as SSSC and it will generate the reactive power to regulate and control the current flow, then the power flow in the transmission line.

Many possible operating modes of the UPFC. Principle operation of shunt inverter is injecting a controllable current in the transmission line. Shunt inverter can be controlled in two different modes:



- VAR control mode:

Shunt inverter control transfer the VAR reference into a corresponding shunt current request and adjusts gating of the establish the desired current where reference input is an inductive or a capacitor VAR request. A feedback signal representing the DC bus voltage, VDC also required for this mode of control.

- Automatic voltage control mode:

To maintain the transmission line voltage at the point of connection to a reference value, the parallel inverter reactive current is regulated automatically. The voltage feedback signal can be achieved by sending end bus feeding coupling shunt transformer for this mode of control.

To influence the power flow of the line, the phase angle and magnitude can be controlled by series inverter controls in order to inject the voltage in series state through the line. The voltage value that injected in a series can be got in different ways.

- Injection of direct voltage mode:

The reference input represents the magnitude and phase angle of series voltage.

- Emulation shifter of phase angle mode:

The reference input can be represented as a displacement between receiving end voltage and sending end voltage.

- Emulation of line impedance mode:

Inserting reference input in series with line impedance.

- Automatic power flow control mode:

Reference input is the value of  $P$  and  $Q$  uphold despite system changes on the transmission line.

### 4.1.3 Control Systems and Control Strategy for UPFC

In UPFC control side, a small amount related work has been done on this subject, for control system design and power flow control, different types of strategies for real and reactive power flow control can be shown as follows:

- **The Strategy of Static Synchronous Series Compensator (SSSC):**

This SSSC method and strategy depend on the transmission line current with injecting series voltage in the quadrature case, letting it to function same as a variable series capacitor, in order to inject the voltage and make it in quadrature with the current of transmission line [30]. By means of adjusting the phase angle of the series injected voltage, the reactive power flow transmission line side voltage might be checked easily. This would be achieved by adding the series injected voltage component with the current of transmission line. The combination of phase and magnitude of series injected voltage is retained. The requirement for coordination controller of a real powerful demand of the series inverter must be achieved by the parallel inverter.

- **The Strategy of D-Q Axis Control:**

The main point of D-Q axis control strategy allows the individual control of the power flow in transmission line by controlling it in an independent way [32]. The series injected voltage can be classified into two components [34]. The first one is in phase beside D axis and the second component in phase with Q axis, in the other side, the transmission line current also classified into two current components; D and Q axis, by using them it can be controlled reactive power in the transmission line. Inequality the Q axis current by using the current of the D axis can regulate and control the real power in the transmission line. Therefore, in phase angle, the series injected voltage D axis that control real power flow by converting the line side voltage and the Q axis component of series injected voltage that controls reactive power to change the phase angle of UPFC bus.

- **Phase Shifter Strategy (PS)**

This strategy can be contingent on injecting series voltage through UPFC bus [33]. Therefore, the bus side of the phase angle can be set for a fixed flow of the real

power of the transmission line. By making a series injected voltage components to be in phase with the UPFC bus as a tap changer strategy. This case will let the phase angle to differ from its quadrature location. That's will change the flow of reactive power in line side voltage.

The parallel inverter might be modeled as a variable shunt capacitor in parallel case with a source of current, the variable parallel inverter capability of compensation and the parallel current source offer the capacity of actual power to charge / release the DC link capacitor, they have careless the model of the parallel inverter transformer are isolated. Therefore, their coordination strategy was done on single machine unlimited bus power system. Thus, no coordination creates between the shunt and series inverter control system [28].

#### 4.1.4 UPFC Modeling

##### 4.1.4.1 Load Flow Models

UPFC parameters are grouped in three categories: power data, shunt converter and series converter. In this thesis a series converter is used. Where it can operate either in power flow control (automatic mode) or in a manual voltage injection mode. In power control mode, the measured active power and reactive power are compared with reference values to produce  $P$  and  $Q$  errors. The  $P$  error and the  $Q$  error are used by two  $PI$  regulators to compute respective the  $Vq$  and  $Vd$  components of voltage to be synthesized by the  $VSC$ . ( $Vq$  in quadrature with  $V1$  controls active power and  $Vd$  in phase with  $V1$  controls reactive power). The reference values of injected voltage  $Vdref$  and  $Vqref$  are used to synthesize the converter voltage as shown in Figure 4.3.

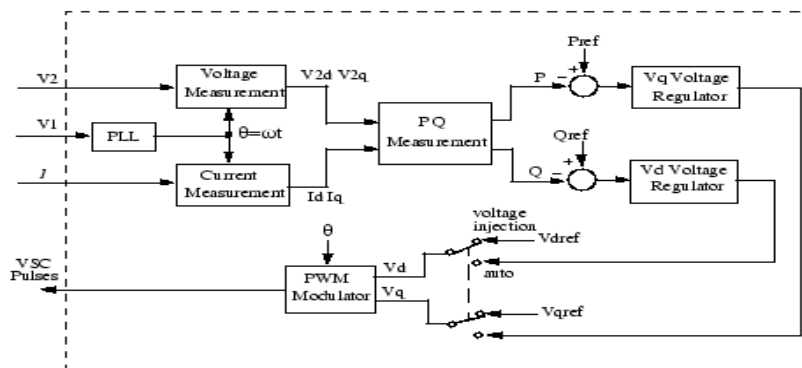

Figure 4.3 Simplified block diagram of the series converter control system

The UPFC controller contains a two inverters, which linking back to back with a capacitor. One of them is connected in parallel with the transmission line, while the second one is linked in series as shown in Figure 4.3. The first modeling efforts for a UPFC were displaying on the series inverter modeling because of the commercial software did not have series voltage supply models.

Load flow model of UPFC consisted of two generators, one of them representing the shunt inverter and the second one is representing the series inverter. These generators were needed to different configuration model [33].

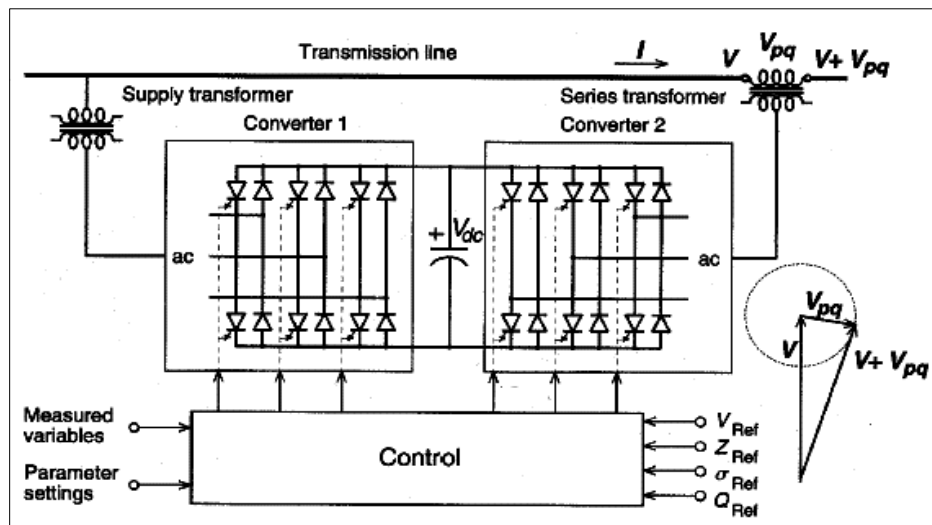

Figure 4.4 UPFC Implementation by 2 back-to-back converters [28]

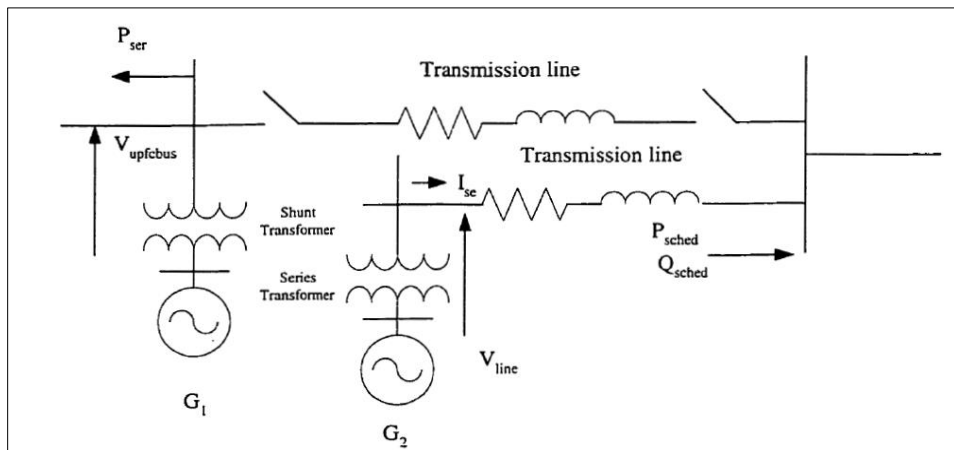

Figure 4.5 Coupled source model for UPFC [10]

The process of solving starts with the series line, and the real and reactive power will generate by Generator #2. This power in the transmission line is converted into an

equivalent at the terminal where Generator #1 is connected. The Generator #1 generates the requirement of the reactive power to obtain bus voltage. Generator #2 also supplies the real power of the series inverter. To maintain the parallel and the series inverters injected voltages for a condition of operation because of this reason of solving load flow with UPFC. Another model for the UPFC where the inverter in shunt case is modeled as a current supply and the inverter in series case is modeled as a voltage supply in series with the transmission line has been used to solve the power flow [33].

Therefore, this model is very good for doing the parametric studies, but not good for solving load flow. Because of the modeling of the shunt inverter by a current supply does not find the phase angle and the voltage of the parallel inverter [31]. The real power of the inverter in series case is achieved by using DC capacitor. Thus, the actual power requirements of the series inverter in steady state should be furnished by the shunt inverter. This model leaves out the interaction between the series and the parallel inverter. A theoretical account which takes the series inverter which modeled as a PV bus, where the shunt inverter is connected is modeled as a PQ bus has been used for load current.

#### **4.1.4.2 Dynamic Model:**

(i) Shunt inverter modeling:

- The current model:

The shunt inverter in this model is pretended to be made of two sources of the current, first one for Q axis and the second one D axis current for connecting to the bus of UPFC.

- The inject of real and reactive power

The inverter in shunt case is modeled as a two power sources connected to the bus of UPFC. One of them is powering source model of real power and the second power source model of reactive power.

- Shunt susceptance in parallel with a current source [33]:

The shunt susceptance model can be deferred by changing the shunt susceptance magnitude.

- The model of voltage source:

The parallel inverter is modelled UPFC bus in shunt with separate voltage source.

- (ii) Series inverter modeling:

It can be modelled as series inverter transformer impedance with a voltage source.

#### **4.1.5 Principle Operation under Line Fault Condition**

The current flows across UPFC's series converter will depend on the position of the fault and also on the impedance of the line. And this current may extend to a value so far from the rating of series converter, this condition will force an UPFC to work as a bypass operating mode. Where, the injected voltage may minimize to zero and the current will depend on this voltage value and bypassed across both of converter valves, it will reconfigured electronically over an isolated high current Thyristor valve or across terminal shorting. For emergency clearing of delayed fault, it must work a mechanical bypass breaker. UPFC will activate the bypass immediately in order to series converter protection, shunt converter still in normal operation during the fault to supply reactive compensation.

### **4.2 Power System Stabilizer**

#### **4.2.1 General Information about Power System Stabilizer (PSS)**

The function of PSS is to add appropriate damping signal to the generator excitation system to cope with parameter oscillations. The functional block diagram of PSS is shown in Figure 4.6. The PSS input signal can be either the frequency difference between remote regions, machine speed deviation or its acceleration power which is the difference between the mechanical input power and the output electrical power of the generator. The output signal is used as an additional input to the excitation system. The function of each PSS block is explained briefly below:

- **The General Gain**

It is used for determines the amount of damping producer by the stabilizer.

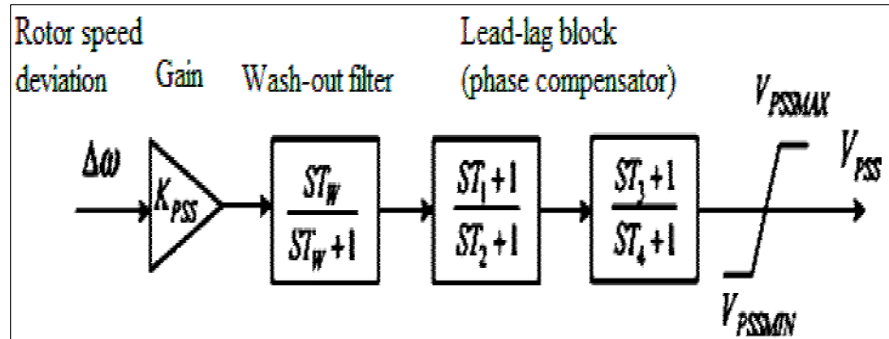

Figure 4.6. PSS structure [55]

- **Washout filter**

The main function of washout filter is to remove the steady state alignment case occurred at the controller output. It is a kind of high pass filter. It is common to select time constant  $T_w$ , between 1-20 s in the literature.

- **Lead-Lag block**

Lead-lag block performs the required phase compensating function for the PSS output, so that the necessary lead or lag function is realized to damp effectively. The transfer function of the lead - lag block is written as:

$$TS = \frac{(1+sT_1)(1+sT_3)}{(1+sT_2)(1+sT_4)} \quad (4.1)$$

where,  $T_1 - T_4$  are time constants, which are strategically chosen for the required phase shift to the PSS output signal. The choice of these time constants are the most difficult ones in PSS design stage.

- **The Limiter**

The main function of the limiter is to give permission to passing a frequency signal of swing mode.

### 4.2.2 Operating Principle of PSS

By controlling the excitation of the generator rotor oscillation by using auxiliary stabilizing signal, recently, PSS is the most excessively prevalence damping controller and it used in all synchronous generators because it has low cost, power system stabilizer PSS is used to this important function damp these oscillation, its operates by adding a signal to the reference voltage signal, based on the automatic voltage regulator AVR and using power deviation, speed deviation, or frequency deviation with additional torque coaxial, for this reason, PSS is prepared, thus, it can increase the damping of low frequencies and developed the dynamic stability. Figure 4.6 illustrates the torque analysis PSS and AVR.

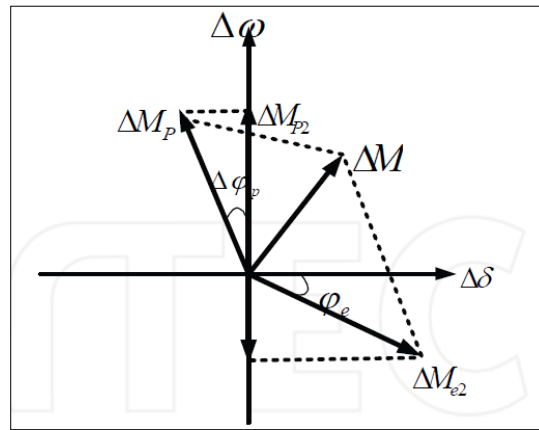

Figure 4.7 Torque analysis between PSS and AVR [36]

The high gain of AVR will give a good voltage control and will increase the opportunities of retaining the synchronizing of the generator at the large disturbance, therefore, this strife is almost solved by limiting the output of PSS to 0.5% set point of the AVR Figure 4.8. Solving of tradeoff can be more elaborately by applying the integration of PSS and AVR and using a design that takes damping and voltage control into account together [39]. The PSS uses a bus frequency or shaft speed active output power as input. The main components of stabilizer consisted of two filters, which are used to phase lag compensation that announced by the field circuit of generator and AVR. And the other filter is often added to minimize the influence on the generators dynamics torsional, and to stop voltage errors caused by frequency requital. The tuning of the lead lag filters will give a speed oscillation of damping torque on generator rotor.by making a difference in the terminal voltage, the effects



of PSS to the flow of power from the generator, which effectively damps the local modes.

PSS has an effect on inter area mode different from the effect on local mode in two sides: one of them is the realizable local mode is more than that in inter area mode, while the other one, mainly the effect of inter area mode through voltage modulation of responsive load. This will make possibility critical characteristics on load both for tuning the field and investigations. The damping of both inter area and local area mode needs an appropriate phase compensation over a great range, which might be very difficult to be realized. The speed signal  $\Delta\omega$  is used by power system stabilizer PSS as an input signal, and it will have a positive compensation of damping torque  $\Delta M_{p2}$ . Therefore, torques of composition, positive synchronous can improve the capacity of oscillation damping [35].

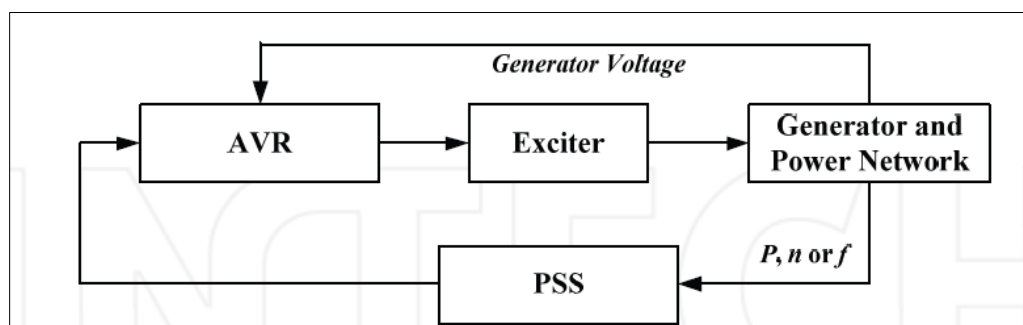
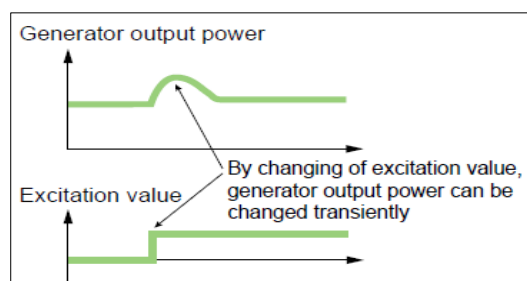

Figure 4.8 Structure of power system stabilizer (PSS) [36]

When the output power of the generator is decided by the mechanical torque of the turbine, this power also can be changed by changing the transient value of the excitation, Figure 4.12a.



(a)

The change of the output power of the generator will be detected by PSS, in a fast way it controls the value of excitation, and it minimizes the power swing more speedily as shown in Figure 4.12b.

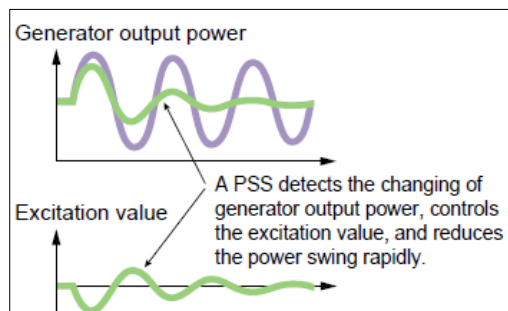

(b)

Figure 4.9 (a), (b) Output power and excitation value [37]

### 4.2.3 Different PSS Actions

#### (i) Power Oscillation Local Mode

- Single oscillates of generator against the system.
- The frequency is about 1Hz.
- Frequency PSS is a Single, such as  $\Delta P$ ,  $\Delta\omega$  or  $\Delta f$ .
- PSS $\Delta P$  type is more efficient as shown in Figure 4.9.

#### (ii) Power Oscillation Inter-area (long-cycle) Mode

- The system oscillates of entire system as a result of large-capacity power transmission, long distance.
- 0.2 to 0.5Hz is the Frequency.
- Frequency PSS is a Single, such as  $\Delta P$ ,  $\Delta\omega$  or  $\Delta f$ .
- PSS  $\Delta\omega$  or  $\Delta f$  type is more efficient.

#### (iii) Power Oscillation Complex mode

- It combines local mode & inter- area mode as shown in Figure 4.10.
- More efficient multi-input PSS.
- $\Delta P + \Delta f$  Type or  $\Delta P + \Delta\omega$  Type [36].

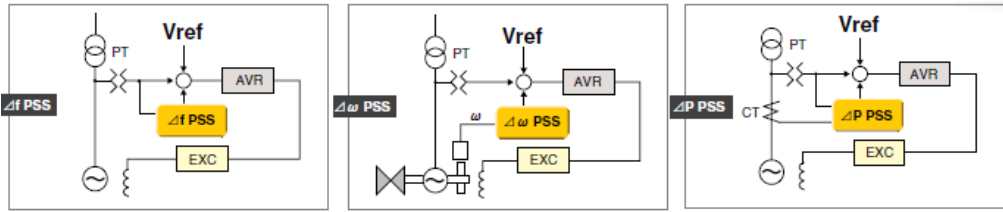

Figure 4.10 Single-frequency PSS [37]

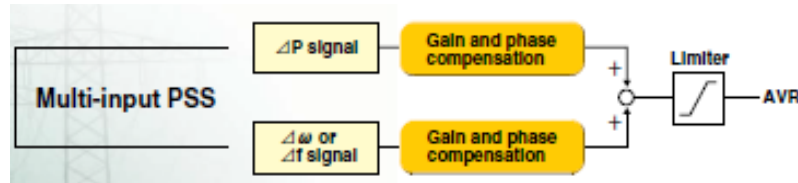

Figure 4.11 Multi-input PSS [37]

#### 4.2.4 PSS Transfer Function

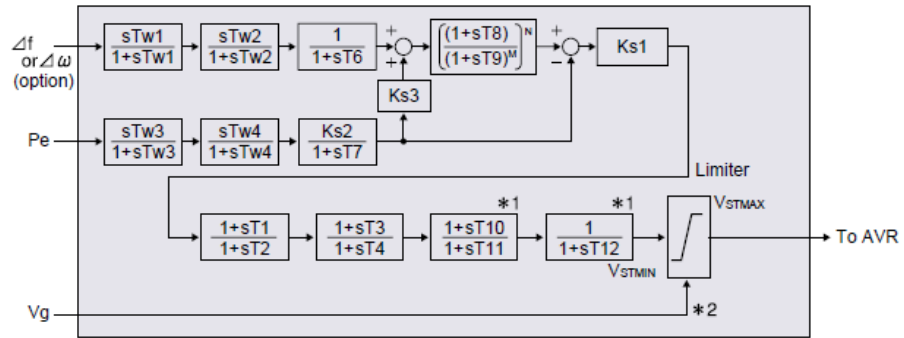

Figure 4.12 Transfer function of PSS [37]

#### 4.2.5 PSS and the Exciter

The model of excitation system involves a fixed exciter which contains a PSS and an AVR, where this contains are washout circuit, a lead lag compensator and the limiter.

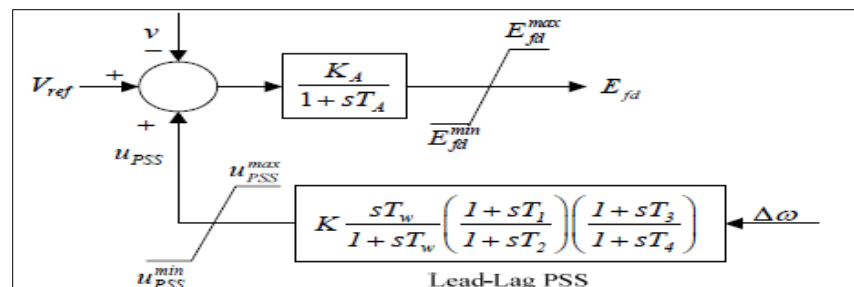

Figure 4.13 Block diagram of excitation system[54]

The traditional lead lag is connected in the feedback loop in order to produce an  $U_{pss}$  an additional stabilizing signal. The dynamic of AVR could illustrate by the equation below [51]:

$$E_{FD} = (K_A(V_{Refi} - V_T + U_{PSS}) - E_{FDi}) / T_A \quad (4.2)$$

Where,  $T_A$  and  $K_A$  are time constant and the gain of the excitation system, and  $E_{FDi}$  is the excitation voltage field, and  $V_{Refi}$  is the reference voltages,  $V_T$  is the terminal voltages of the machine, and  $U_{pss}$  is the signal of the control [51]. The unbalance of voltage which produced by the fault might be a reason to distortion on the currents. If the fault current is achieved by bypass electronic switch, it must be dissipated delayed close to the thermal capacity of this switch [48].

### **4.3 Power System Damping Equipments:**

#### **4.3.1 UNITROL stand-alone PSS.**

It is an easy-to-use, reliable equipment and mainly intended for the improvement of the damping of the electromechanical oscillations by appropriate influencing the automatic voltage regulator control loop for the synchronous generators.

Nowadays, new excitation systems for medium-power and high-power generators are almost always supplied with an integrated PSS. For existing power stations, where a complete replacement of the excitation systems is not planned, there are good reasons to equip the existing voltage regulators with PSS. Increasingly, network operators demand that the power producers make an active contribution to network stability. In many cases, this can increase the working range of the generator, especially in terms of reactive power consumption capacity.

The ABB stand-alone PSS, shown in Figure 4.14, has been specially developed for these applications. This stabilizer is suitable for supplementing not only ABB Automatic Voltage Regulators (AVR) / Static Excitation Systems (SES), but also for those of other manufacturers. Its cost is about 10350\$.



Figure 4.14 Unitrol stand-alone PSS

#### 4.3.2 The EM Test OCS 500N6F Damped Oscillatory Wave

It includes the test capabilities for fast damped oscillatory waves at 3MHz/10MHz/30MHz up to 4.4kV and is extendable for slow damped oscillatory waves at 100kHz/1MHz up to 3.0kV (as per [IEC 61000-4-18](#)) and for ringwave up to 6kV as per [IEC 61000-4-12](#) as shown in Figure 4.15. Damped Oscillatory Waves are repetitive transients mainly occurring in power, control and signal cables installed in high voltage and medium voltage stations, divided into slow and fast damped oscillatory waves. The Ringwave is a non-repetitive damped oscillatory transient occurring in low-voltage power, control and signal lines supplied by public and non-public networks. The OCS 500N6F can also be used to perform magnetic field tests as required in [IEC 61000-4-10](#) using a magnetic field coil such as the MS 100N. Also compliant with the [ANSI/IEEE C37.90](#). It's cost about 10000\$.



Figure 4.15 Damped oscillatory wave and ringwave simulator

### 4.3.3 Simulator EM-Test OCS 500N6F For Fast & Slow Damped Oscillatory Waves

The OCS 500N6F series includes the test capabilities for fast damped oscillatory waves at 3MHz/10MHz/30MHz up to 4.4kV and is extendable for slow damped oscillatory waves at 100kHz/1MHz up to 3.0kV (as per EN/IEC 61000-4-18) and for ringwave up to 6kV as per EN/IEC 61000-4-12 as shown in Figure 4.16. Damped Oscillatory Waves are repetitive transients mainly occurring in power, control and signal cables installed in high voltage and medium voltage stations, divided into slow and fast damped oscillatory waves. The Ringwave is a non-repetitive damped oscillatory transient occurring in low-voltage power, control and signal lines supplied by public and non-public networks. It's cost about 8000\$.



Figure 4.16 Simulator For Fast & Slow Damped Oscillatory Waves & Ringwave

## **CHAPTER 5**

### **COORDINATION OF UNIFIED POWER FLOW CONTROLLER AND TWO POWER SYSTEM STABILIZERS**

#### **5.1 Introduction**

PSO algorithm is used in this thesis to solve optimization problems of an UPFC and three PSS controller by using time domain simulation. The unified power flow controller is the most versatile member of FACTS devices, which is applied in power systems. This controller can work in an effective method with STATCOM and SSSC. This combination between them makes the UPFC has both advantages of those two devices, and it requires to be finish many works of power transmission system like enhancement of transient stability, damping the oscillations and control of voltage. It is the best and a very useful controller from FACTS devices and it appears to optimize and control the power flow in transmission systems. It has great potential advantages of dynamic and static operation of transmission lines. Where it combines the basic features of both STATCOM and SSSC.

The UPFC can control all the parameters instantaneously that effect on power flow in the transmission line like, phase angle, voltage and impedance. On the other hand, it can individually control both the real and reactive power flow in the transmission line. The UPFC is a combination of static series compensation and static compensator. Its effect as a shunt compensation and a phase shifting device simultaneously. Generally, UPFC is connected to the power systems in long transmission lines. And it works in an efficient way, to damp power system oscillation. Today, a new method called Particle Swarm Optimization PSO is very general technique to coordinate designing PSS and UPFC controller. Because of the advantages of PSO, a robust of PSO to find a better solution and capability to supply a close best solution.

## 5.2 Coordinated Design of UPFC and PSS

A famous optimizing technique can be used for designing and coordinating between UPFC as a damping controller and PSS in multi-machine power systems [40]. Which called Particle Swarm Optimization PSO where it applied to simultaneous designing to make the coordination in multi-machine power system. The coordinated design problems for both controllers cross a big range under conditions of load are formulated as an optimization problem (multi-objectives). Both controllers performances will test under weak connect condition in power system where it subjected to system parameter variations, loading conditions and different disturbances such as line faults [41].

The presented controllers should have the ability to run very well under whole operating conditions, while the enhancement of the damp the critical modes is important. We're the choice of the parameters of both UPFC and PSS is a complex optimization problem. On the other hand to obtain an optimal combination between them and to enhance the synthesis of optimization and finding the global best values. This algorithm has been applied [41]. A performance index:

$$ITAE = \int_0^{\infty} t |e(t)| dt \quad (5.1)$$

Performance index in equation (5.1) has very important advantages of generating a smaller oscillation and overshoots than the other types of performance indices. Because of the tuning conditions of PID are based on a 1st - order assumption of plus time delay of the system where it may cannot confirm the good performance of the controller. But by using the *ITAE* the modern optimization techniques where it gives us the ability and possibility to finishing the tuning the PID controller based on the transfer function of the system in order to finish and optimize the performance of the closed - loop system.

Any particle should have a speed which defines the distance and the direction of particle flight. The second step each particle must follow the present optimal and search for solutions in the space. The PSO is prepared to be a collection of the particles, and the final step is, the when a particle find an optimal solution that will present as a "extreme value" and it can be done by particle itself, and it is called



"*Point\_Best*" of the individual extreme, and the second extreme, where the particle find the optimal solution of global extreme by entire population which called "*Group\_Best*" [45]. The problems based on the system dynamics after fault occurs in the system is prepared and will use as an objective function for design problem. An *ITAE* is used because of variation operating conditions in the power systems.

Because of several advantages and many features, the PSO observed that it may cannot perform as an expectation. And this case will easily blunder into the solutions of the local optimal when complex relative with optimization problem cannot hurdle ended the impediment. Today, many surveys have been assumed to enhance the performance of the PSO where variable coefficient of acceleration is presented.

### 5.3 Particle Swarm Optimization

The PSO is a new optimization technique established by Kennedy and Eberhart in 1995[55]. This algorithm is related to social manner of bird grouping. The system via informing the generations can initialize with a population of arbitrary results and searches. On the other hand, it has no crossover and mutation operators. In PSO, the particles word means: the solutions of potential and it has the ability to fly across space of the problem using the result of present optimal particles. By making some compares with Genetic Algorithm GA, PSO has many advantages such as, it is easy to complete, and it has a few number of operators which needs to adjust. Also, it has the ability to implement in numerous zones.



Figure 5.1 Movement of particles like birds [55]

The PSO is a standard algorithm works with a particle population. By flying across the infinite number of spaces, the particles looking for the functions and try to be

optimize them. Any particle has a state and it can be signified by its location  $X_i = (X_{i1}, X_{i2}, \dots, X_{in})$  and its velocity  $V_i = (V_{i1}, V_{i2}, \dots, V_{in})$ , that's will lead to updating the particle states. To get updates of velocity, there are three parameters can be used as a key, the first parameter is the component of momentum, here, its check the ability of the particle to remember and control its earlier velocity, the second one, it is the component of cognitive. In this component, it is check the capability of the acceleration constant  $C1$  to control the particle better position and the third one; mentioned to the component of social, the constant acceleration  $C2$  will control this propensity, where try to put the particle near swarms best position according to the equations below [46]:

$$v_{id}^{k+1} = w \cdot v_{id}^k + c_1 \cdot rand_{gd} \cdot (p_{id}^k - x_{id}^k) + c_2 \cdot rand_{id} \cdot (p_{gd}^k - x_{id}^k) \quad (5.2)$$

$$x_{id}^{k+1} = x_{id}^k + \mu \cdot v_{id}^{k+1} \quad (5.3)$$

$$|v_{id}^k| \leq V_{mm} \quad (5.4)$$

$$|x_{id}^k| \leq X_{mm} \quad (5.5)$$

In the formula above;  $v_{id}^k$  represents:  $k$ -th, the generation,  $i$ -th is the particle,  $v$  –the velocity,  $d$ - dimensional. The formula  $x_{id}^k$  represents:  $k$ -th the generation,  $i$ -th is the particle,  $x$  is the location,  $d$ -dimensional.  $w$  is the inertia factor.  $\mu$  is the speed ratio constraint factor.  $P_{id}^k$  is the position optimal value of each particle.  $P_{gd}^k$  is the group location optimal value.  $C_1, C_2$  are the accelerating factors.  $V_{mm}$  is the speed range, and it limits the individual trend.  $X_{mm}$  is population range. The PSO can take the stimulus from this model and it can be used to explain the problems. In the particle swarm optimization, each solution can consider it as a bird in the space. These particles have a value that could be optimized by function, and the fitness value can be determined by the integral equation of performance index equation given in (5.1).

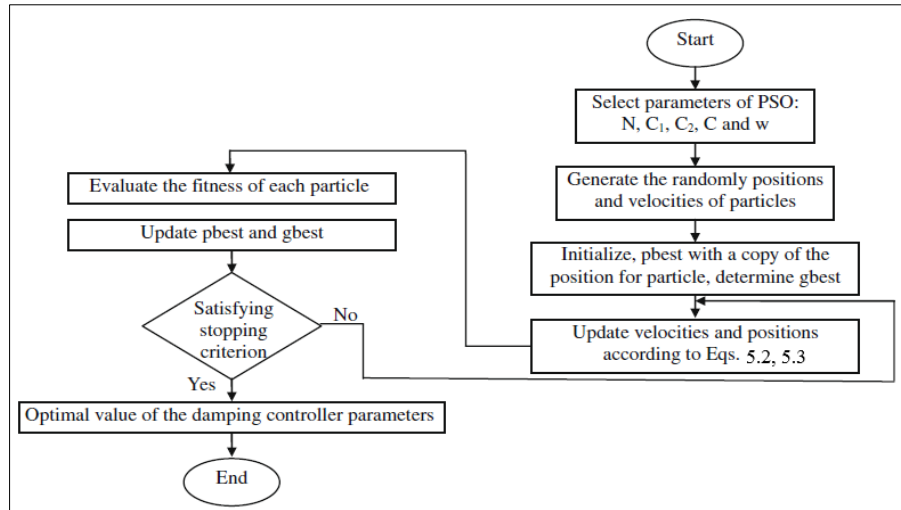

Figure 5.2 Flowchart of PSO [56]

#### 5.4 PSO Iteration

PSO algorithm has iteration state when a particle population is looking for a better solution, updating their positions depending on three components. At each iteration, any particle evaluates its velocity via its earlier velocity, its best earlier position and its neighborhood best position. The earlier established the component of momentum, the earlier best\_position finds the reasoning component, and the neighborhood's best earlier position creates the common iteration component. The iteration algorithm has different variations as shown in Figure 5.3.

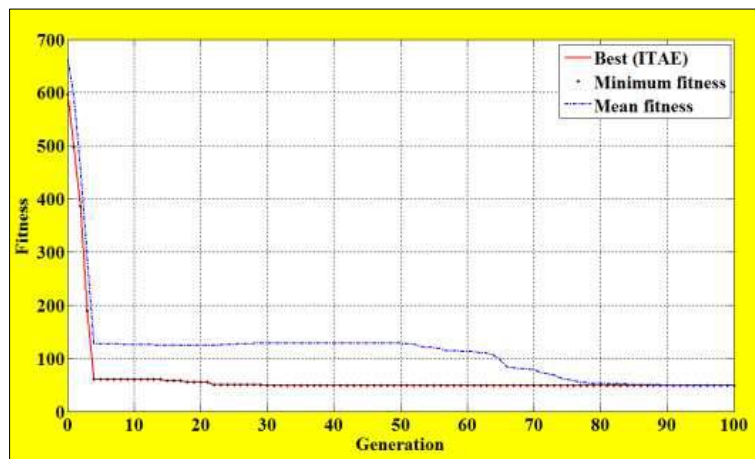

Figure 5.3 Decreasing the cost function by iteration

## 5.5 Integrating M-File with the Power System Simulink Model

In this model the optimization 17 parameters of 3PSS. When the PSO program run, it will generate a value for the variables above as well as  $K_p$ ,  $K_i$  for power regulating of UPFC and it compensate these values in simulation model and using the acceleration power  $P_a$  (difference between mechanical power  $P_m$  and the electric power  $P_e$ ) as an input signal of Integral Time Absolute Error (ITAE) of model, this value is represent the fitness value of PSO, this value will return to PSO program, and using it as an initial value in order to improve the values that we need to find the optimal situation of them, then PSO start repeats this process depending to the maximum iteration number then it will stop running, at end of the iteration we will get the optimal values of variables.

## 5.6 Parameters Constrains

In order to get the optimal values of the parameters, the limitation constrains of it should be adjusted in a suitable value, in this thesis we used this constrain between the high value and low value for the 17 parameters of three PSS, two PSS from them related to the two generation areas and the third PSS is related to the UPFC damping controller as well as two parameters of power regulation gains.

In this thesis, the performance index (5.1) of acceleration power ( $P_a$ ) Is given as:

$$P_a = P_m - P_e \quad (5.6)$$

where  $P_m$  Is a mechanical power of the generator and  $P_e$  Is an electrical power of it. This acceleration power  $P_a$  Considered as an objective function given below:

$$J = \int_{t_0}^{t_{sim}} t. |\Delta P_a|. dt \quad (5.7)$$

Where  $t_{sim}$  is the time of simulation and  $\Delta P_a$  is the deviation of power acceleration, the optimization problem is subjected to the following inequality constraints:

Minimize J

Subjected to

$$K_p^{min} \leq K_p \leq K_p^{max} \quad (5.8)$$

$$K_i^{min} \leq K_i \leq K_i^{max} \quad (5.9)$$

$$K^{min} \leq K \leq K^{max} \quad (5.10)$$

$$K_a^{min} \leq K_a \leq K_a^{max} \quad (5.11)$$

$$K_b^{min} \leq K_b \leq K_b^{max} \quad (5.12)$$

$$T_1^{min} \leq T_1 \leq T_1^{max} \quad (5.13)$$

$$T_{1a}^{min} \leq T_{1a} \leq T_{1a}^{max} \quad (5.14)$$

$$T_{1b}^{min} \leq T_{1b} \leq T_{1b}^{max} \quad (5.15)$$

$$T_2^{min} \leq T_2 \leq T_2^{max} \quad (5.16)$$

$$T_{2a}^{min} \leq T_{2a} \leq T_{2a}^{max} \quad (5.17)$$

$$T_{2b}^{min} \leq T_{2b} \leq T_{2b}^{max} \quad (5.18)$$

$$T_3^{min} \leq T_3 \leq T_3^{max} \quad (5.19)$$

$$T_{3a}^{min} \leq T_{3a} \leq T_{3a}^{max} \quad (5.20)$$

$$T_{3b}^{min} \leq T_{3b} \leq T_{3b}^{max} \quad (5.21)$$

$$T_4^{min} \leq T_4 \leq T_4^{max} \quad (5.22)$$

$$T_{4a}^{min} \leq T_{4a} \leq T_{4a}^{max} \quad (5.23)$$

$$T_{4b}^{min} \leq T_{4b} \leq T_{4b}^{max} \quad (5.24)$$

To find the optimal values of parameters, the PSO start using the values between minimum and maximum range of all parameters, and when the particle of each

parameter fix the suitable value as shown in Table 1. That have the same value of previous attempt (position and velocity), this value will use as a reference value by fitness order in PSO algorithm.

We got these values under fault (single phase line - ground) condition where applied in middle distance of 2- areas power systems with UPFC and 2PSS.

Table 1. Optimal parameters of controllers

		Initial values of parameters	Converged values
PSS parameters of G1	$K$	0 – 1.5	1.3160
	$T_1$	0 – 0.5	0.4649
	$T_2$	0 – 1.0	0.9367
	$T_3$	0 – 0.5	0.3460
	$T_4$	0 – 1.0	0.9166
PSS parameters of G2	$K_a$	0 – 1.5	0.2269
	$T_{1a}$	0 – 0.5	0.3921
	$T_{2a}$	0 – 1.0	0.0654
	$T_{3a}$	0 – 0.5	0.0139
	$T_{4a}$	0 – 1.0	0.4385
PSS parameters of UPFC	$K_b$	0 – 1.5	0.2778
	$T_{1b}$	0 – 0.5	0.0798
	$T_{2b}$	0 – 1.0	0.3805
	$T_{3b}$	0 – 0.5	0.4437
	$T_{4b}$	0 – 1.0	0.2282
UPFC real power control parameters	$K_p$	0.01 – 0.05	0.0344
	$K_i$	5 – 7	6.8507

## CHAPTER 6

### SIMULATION STUDIES

#### 6.1 System Model

The 2-area power system including an UPFC and 2-PSS is shown in Figure 6.1 where used to control the power flow in a transmission system 500 KV /230 KV and damping the electro-mechanical oscillations. UPFC is used where this system is configured in loop case and it contain of 5 buses where interconnected via the three lines and two transformer banks 500 kV/230 KV (Tr1 and Tr2). Two generators are generating a total of 1500 MW, which is transmitted to a 15000-MVA 500-KV equivalent and to a 200-MW load which connected at bus B3. Each generator consists of a power system stabilizer (PSS), an excitation system as well as a speed regulator, the operation in normal case, most of the 1200-MW generation capacity of generator #2 is transferred to the 500-KV equivalent via three 400-MVA transformers. We are considering an eventuality state where only two transformers out of three are available ( $Tr2= 2*400 \text{ MVA} = 800 \text{ MVA}$ ).

The Simulation model consist of the following components:

- Two power generating units of 13.8 KV, 1000 MVA and 13.8 KV, 1200 MVA, the type of rotor is Salient pole and a couple of transformers they have the same rating.
- Two transformers 800 MVA and 1200 MVA of UPFC.
- Three lines L1, L2, L3, each of 100 Km.
- Five buses (B1 to B5) and UPFC controller.
- Three phase load of voltage 500 KV and power of 200 MW at B3 and UPFC
- Threephase fault breaker in middle point of line.
- Equivalent three phase source 500 KV, 15000 MVA.

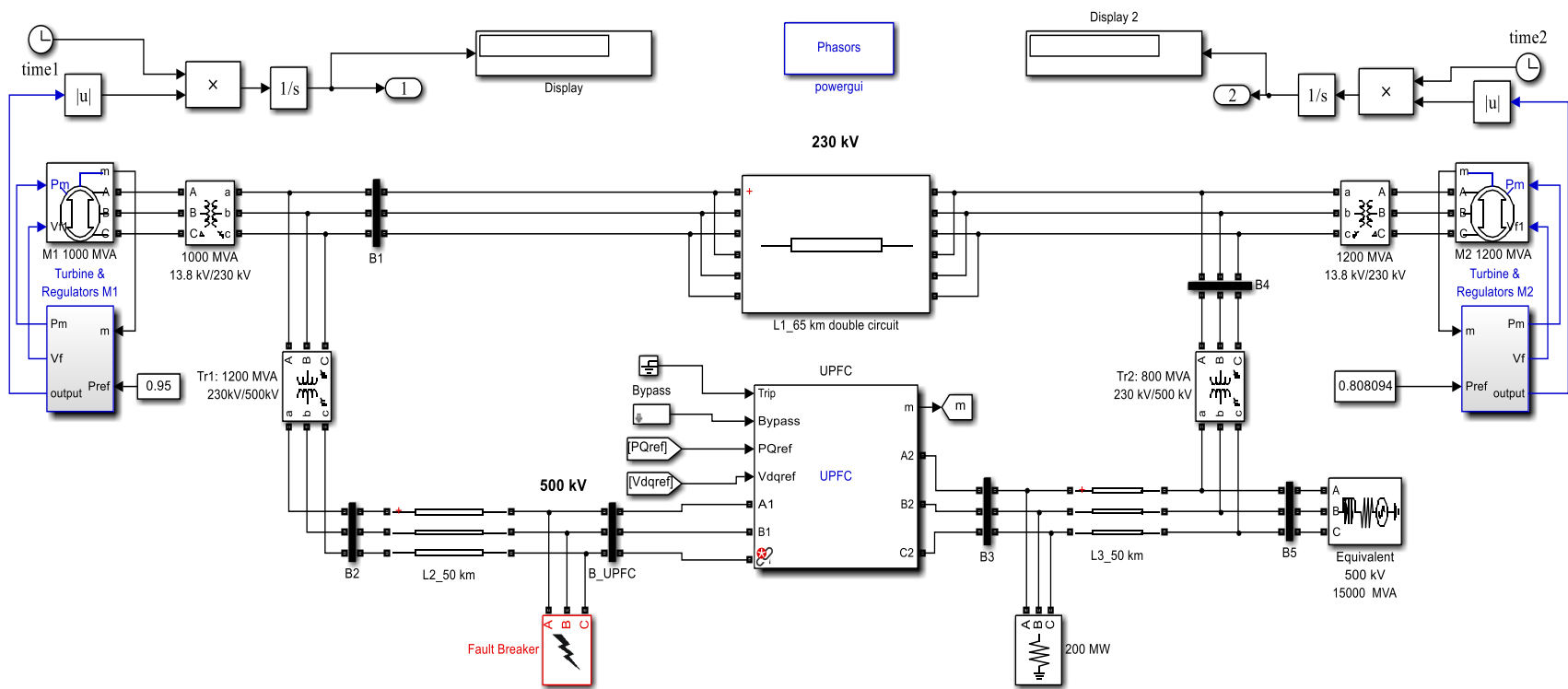

Figure 6.1 Simulation model



## 6.2 Simulation Studies

The system model in Figure 6.1 is tested under various conditions in four case studies: uncoordinated designed (with UPFC and without 2PSS), coordinated design during faults duration 0.1-0.2sec (with UPFC and with 2PSS), robustness test with fault duration 0.1-0.3sec and robustness test under double phase with Ground fault.

The different case studies test conditions are:

**6.2.1 Case Study 1:** Simulation results of uncoordinated designed 2PSS and UPFC controller.

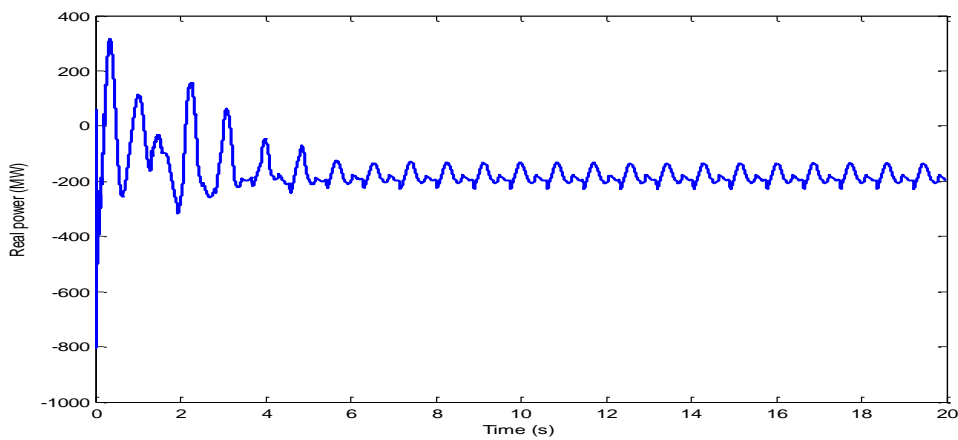

Figure 6.2 The oscillations in real power under fault without multiple PSS

Big oscillations will appear in line power after a fault (duration 0.1-0.2sec), (Phase A with Ground) and this power will reach 650MW in an unstable state and these oscillations will damp gradually (about 565 MW) after UPFC controller starting and stay at the same value after 6sec until end of iteration at 20 sec and this power will stay in unstable case, the controller will damp the oscillations and the power will fix about 85 MW (between -125 and -210 MW). The oscillations are shown in Figure 6.2.

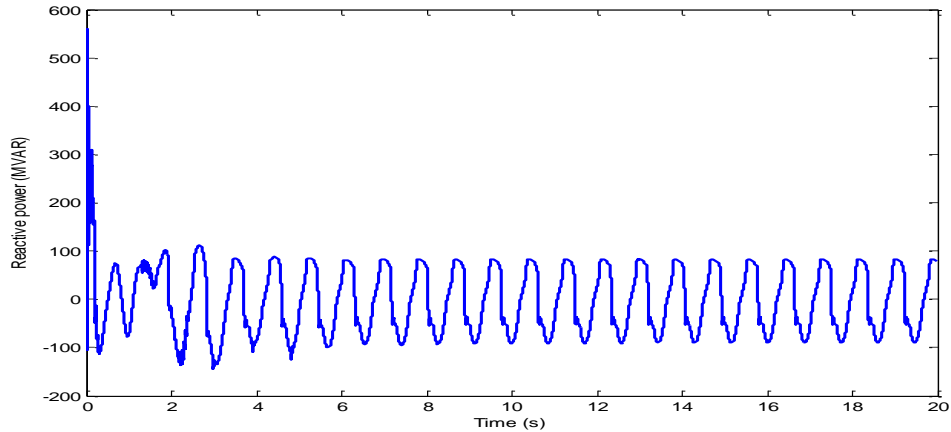

Figure 6.3 The oscillations in reactive power under fault without multiple PSS

The reactive power also has a great oscillation after a fault and its reach to 430 MVAR (320 to -110) between 0.1 and 0.2sec and when the UPFC damping controller start work, these oscillations will damp gradually and fix to 180 MVAR between 4 and 20sec, the controller will damp about 250 MVAR but the system still in unstable state. The oscillations are shown in Figure 6.3.

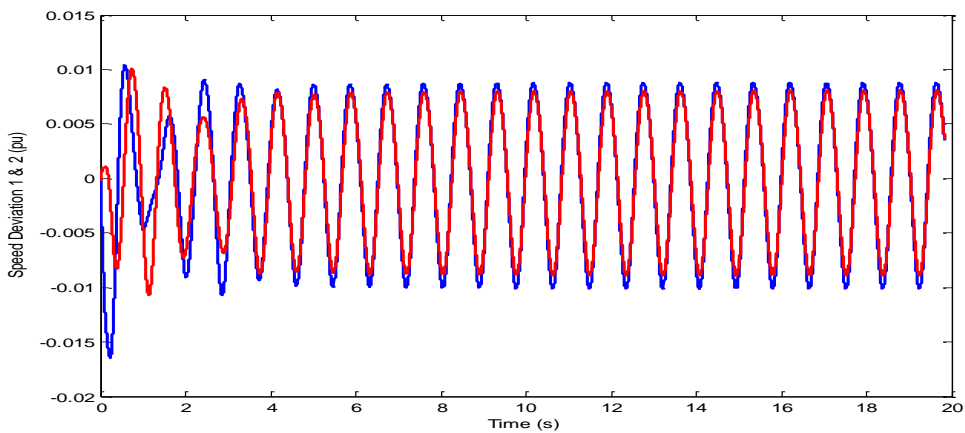

Figure 6.4 The speed deviation of rotors under fault without multiple PSS of G#1 (blue), G#2 (red)

The oscillations will effect on the speed deviation of two generators G1 and G2, after fault this effect will be differ from G1 that has low load (1000MW) and G2 that has big load (1200MW), these oscillation in speed will reach (0.011 to -0.0165 (pu)) for G1 and (0.01 to -0.007 (pu)) for G2 (0.1 - 0.2sec), we can see from the speed wave that the effect of the oscillations on generators G1 is bigger than G2 because of low

load, after controlling start, the oscillations will damp and stay in unstable state (0.008 to -0.008 (pu)) for G1 and (0.006 to -0.006(pu)) for G2 because of different generation. The oscillations are shown inFigure 6.4.

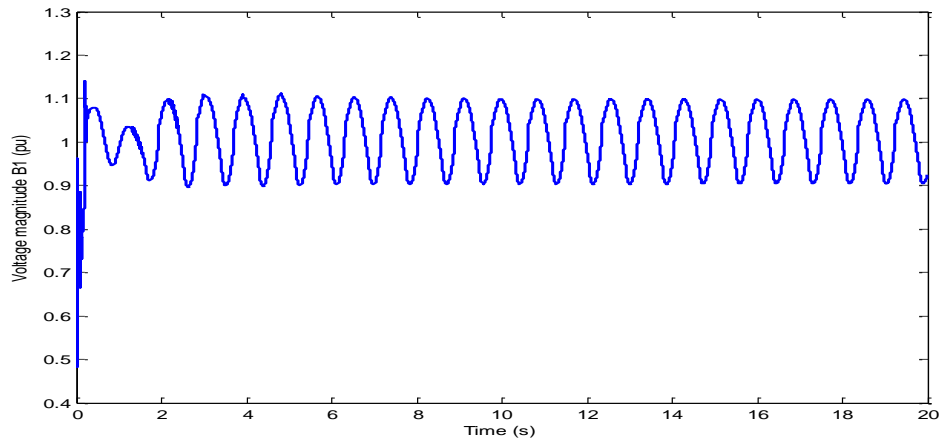

Figure 6.5 The voltage magnitude of bus 1 under fault without multiple PSS

The oscillations in the line will effect on voltage magnitude of all buses, we can show this effect clearly on bus 1 in figure 6.5 above, after fault, this magnitude will reach a maximum value in (pu) about (0.65 to 1.15 (pu)), after controlling work this oscillation will start to damp until reach fix magnitude (0.95 to 1.08 (pu)). The oscillations are shown in Figure 6.5.

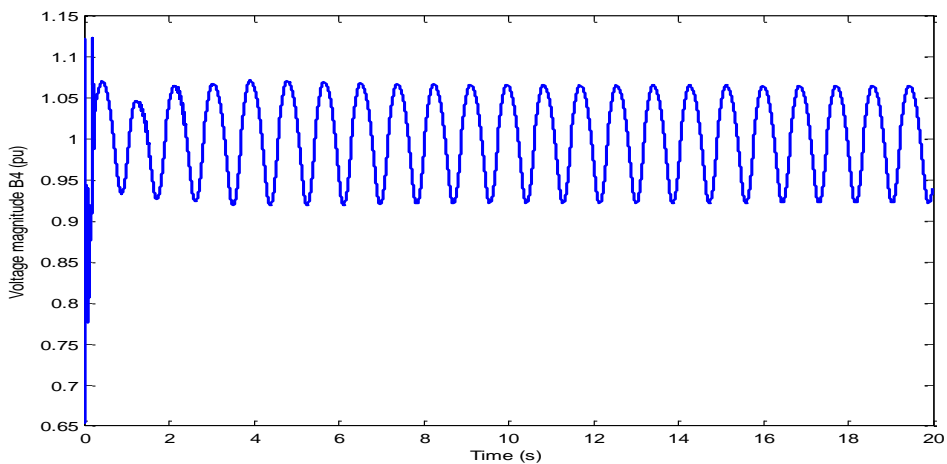

Figure 6.6 The voltage magnitude of bus 4 under fault without multiple PSS

The oscillations in the line will effect on voltage magnitude on bus 4, after fault this magnitude will reach a maximum value in (pu) about (0.77 to 1.13 (pu)), after

controlling work this oscillation will start to damp until reach fix magnitude (0.93 to 1.07(pu)). We can see the clear effect of fault distribute on voltage magnitude in bus 4 because of the location of fault in middle point of transmission line. The oscillations are shown in Figure 6.6.

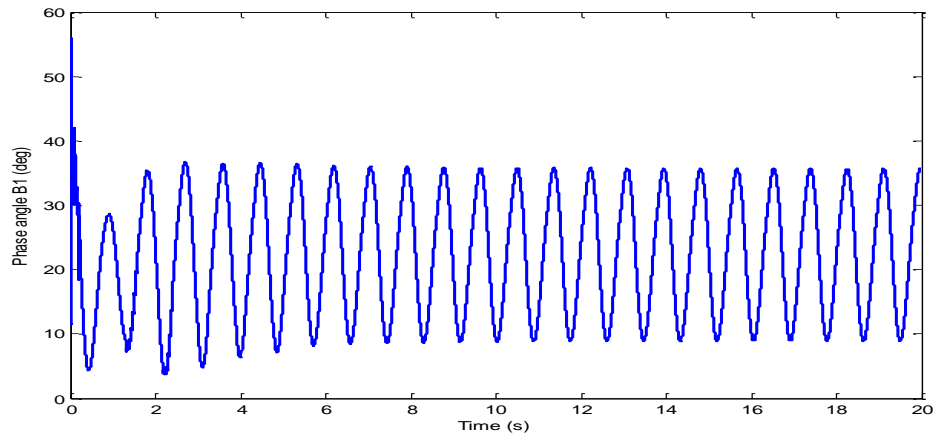

Figure 6.7 The phase angle of voltage under fault at bus 1 without multiple PSS

Phase angle of bus 1 effect by fault and this fault also make a changing in the degree of the phase angle, we can show the changing in the degree after fault (5-29). When controller starts to damp these oscillations that appeared in the line, the phase angle fixes in value about 10-32° (about 22°) for B1. The oscillations are shown in Figure 6.7.

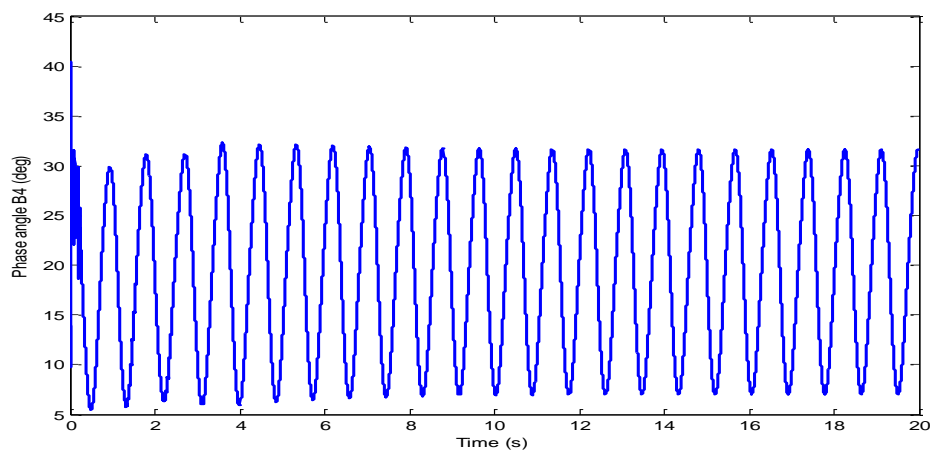

Figure 6.8 The voltage phase angle of bus 4 under fault without multiple PSS

Phase angle of Bus 1 effect by fault and this fault also make a changing in the degree of the phase angle, we can show the changing in the degree after fault between 6 to 30 deg. About  $26^\circ$ . When controller start to damp these oscillations that appeared in the line, the phase angle degree fixes in value about  $7-34^\circ$  ( $27^\circ$ ) for B4. The oscillations are shown in Figure 6.8.

The Figures above shows that the uncoordinated design between UPFC and 2PSS when neglected the damping effect of the PSSs will give us a limit damping of inter area oscillations. So in order to get the full and fast damping of these oscillations it should be made a coordination between these controllers.

**6.2.2 Case study 2:**Simulation results of coordination, design 2PSS and UPFC controller.

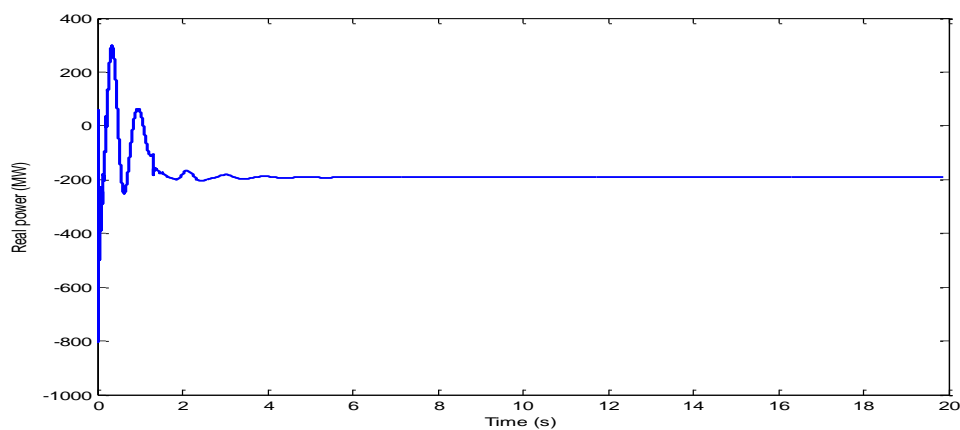

Figure 6.9 the oscillations in real power under fault with multiple PSS

The excellent damping of inter area oscillations between two areas can be seen in Figure 6.9 when fault disturbance applied (0.1 - 0.2 sec), the oscillation in the increase rapidly 650 MW from -350 MW to +300 MW about, at this moment the damping controller start to damp this oscillation (1sec - 5sec), when the wave reach 5sec, the controllers will make those oscillation to be zero with no oscillations and the system will be stable after 5 sec and it will continue in stable state until end of simulation time. The oscillations are shown in Figure 6.9 and the load will reach -190 MW.

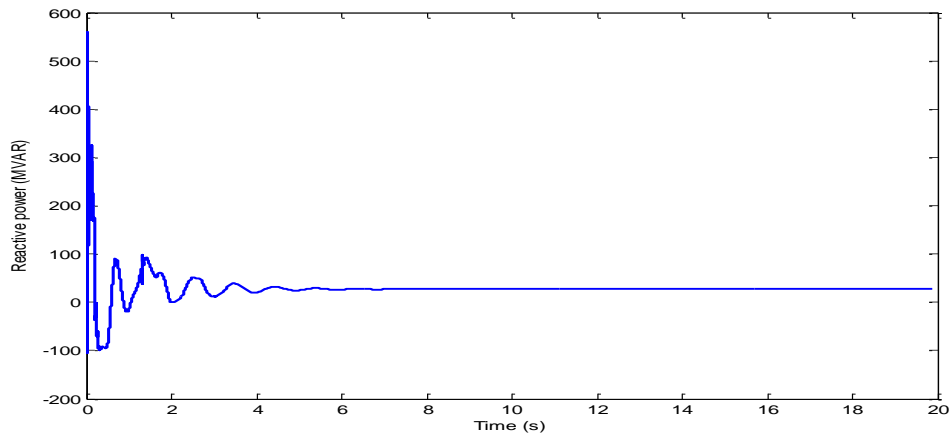

Figure 6.10 The oscillations effect in reactive power under fault with multiple PSS

When the fault occur, the reactive power will change suddenly about 430 MVAR from 320 MVAR to -110 MVAR, when the controllers enter in work, these oscillation will damp in rapidly until making these oscillation zero value and the magnitude of the reactive power reach 30 MVAR with no oscillations when the time reach 7sec and these oscillations stile in zero value until end of simulation time as shown in Figure 6.10.

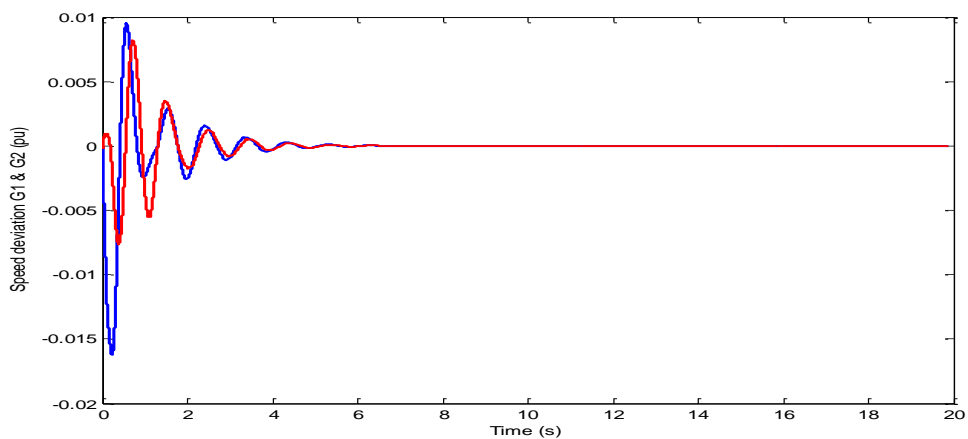

Figure 6.11The speed deviation of rotors under fault with multiple PSS of G#1 (blue), G#2 (red)

Figure 6.11 illustrate the speed deviation has oscillations where effected by fault occurring (0.1- 0.2sec), the speed wave of G1 change in range -0.0165 to 0.009 (pu), whereas G2 changing in range -0.0075 to 0.008 (pu) after fault and these oscillations

will damp rapidly when the controllers start running and at time 6.5 sec the oscillation will damp quickly and it became zero and stay in that value until 20 sec.

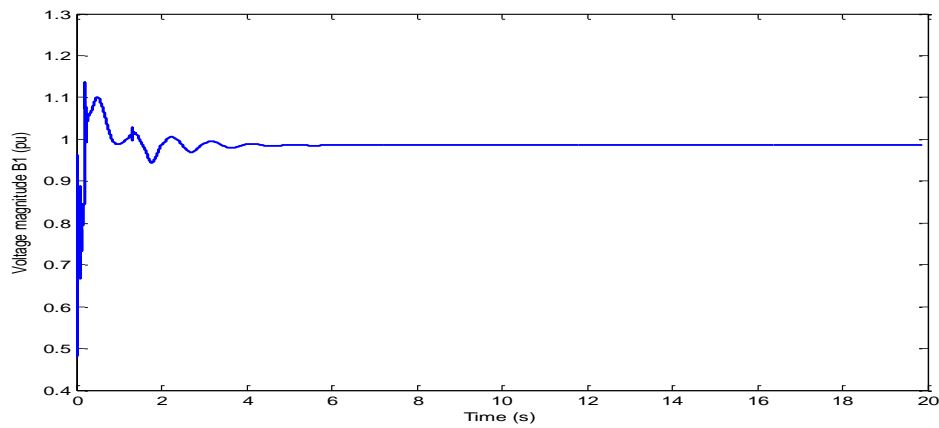

Figure 6.12 The voltage magnitude of bus 1 under fault with multiple PSS

The Figure 6.12 above shows the voltage magnitude of bus 1 where changes from 0.66 to 1.13 (pu) after a fault, and the oscillation occurs in the wave and it reaches the maximum value at time 0.2Sec and it will damp in fast to zero when the time reaches 5 Sec and the system be stable until the time be 20 Sec the end of simulation time.

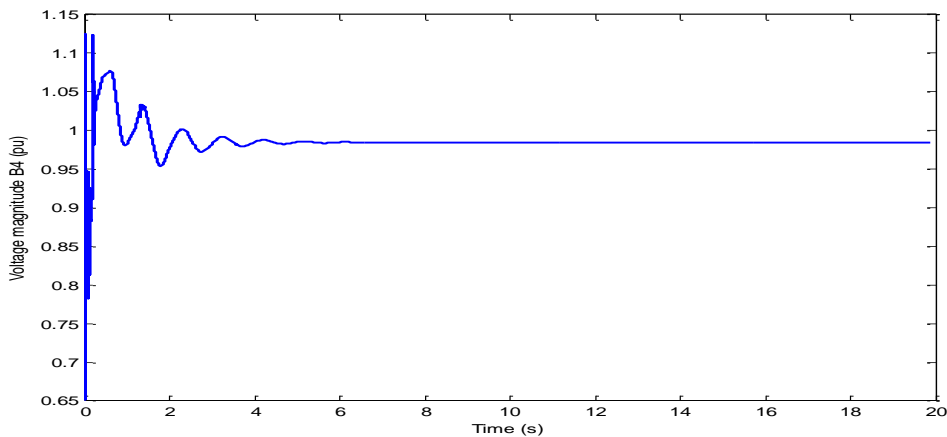

Figure 6.13 The voltage magnitude of bus 4 under fault with multiple PSS

The same case of the voltage of bus 4, it also effect by the occurring of oscillation in the line and it will change in range 0.77 to 1.13 (pu), and it will damping in rapid way when the time reach 6.3sec and will stay in stable state to 20sec the end of simulation time as shown in Figure 6.13.

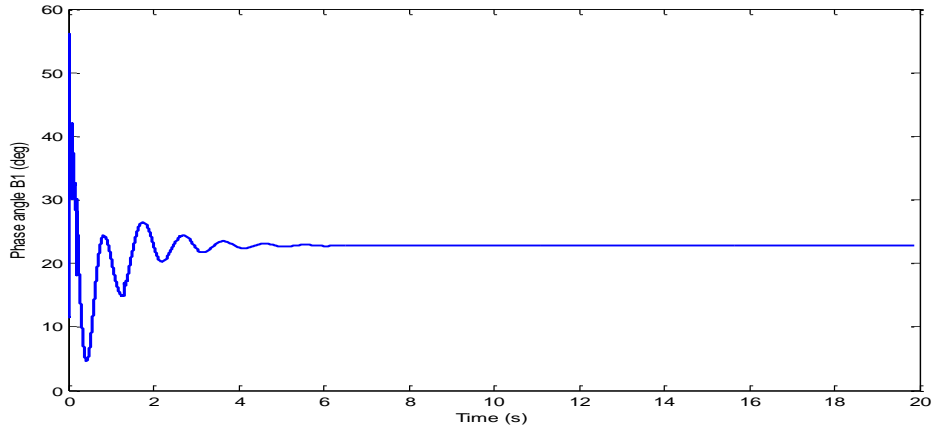

Figure 6.14 The voltage phase angle of bus 1 under fault with multiple PSS

It can be illustrate from the Figure 6.14 the voltage's phase angle of bus1 will effect by fault after 0.1 sec the time of fault starting and it is finish at time 0.2sec, this angle will change suddenly and it reach 25° (from 42 to 5 degree), this oscillation and distortion in the wave shape will damp immediately and it became zero at 7 sec and continue in zero value until reach the end of simulation time.

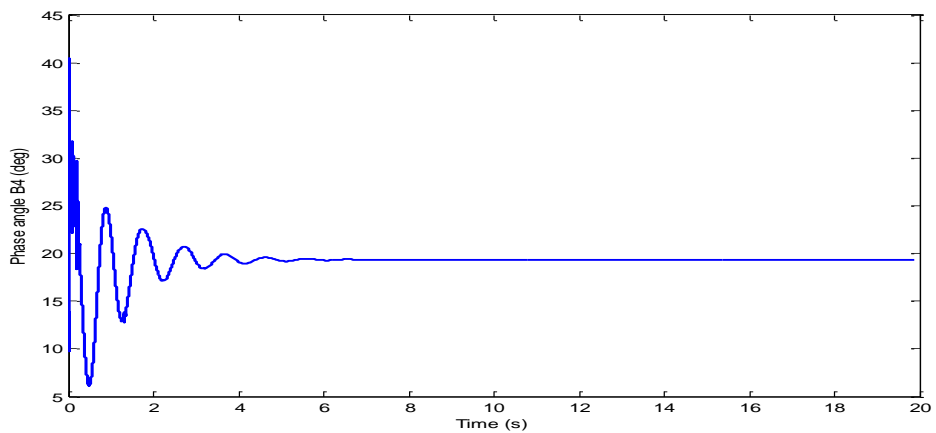

Figure 6.15 The voltage phase angle of bus 4 under fault with multiple PSS

The voltage's phase angle of bus 4 also has an oscillation after fault where it change from 40° to 6° and it damp in rapid way and it fix at 18° when the time be 6.5sec to 20sec the point of end of optimization process as shown in Figure 6.15.



### 6.3.3 Case study 3: Simulation results of double phase with ground fault.

In order to check the robustness of damping the oscillations, we used the fault duration (0.1- 0.2sec), we can show the results and Figures which related to real power, reactive power, speed deviation of two generators, voltage and phase angle of two buses 1 and 4, we applied a double fault with ground (phase A, B) for testing the robustness of the model and PSO algorithm to damp the inter area oscillations in 2-area power systems.

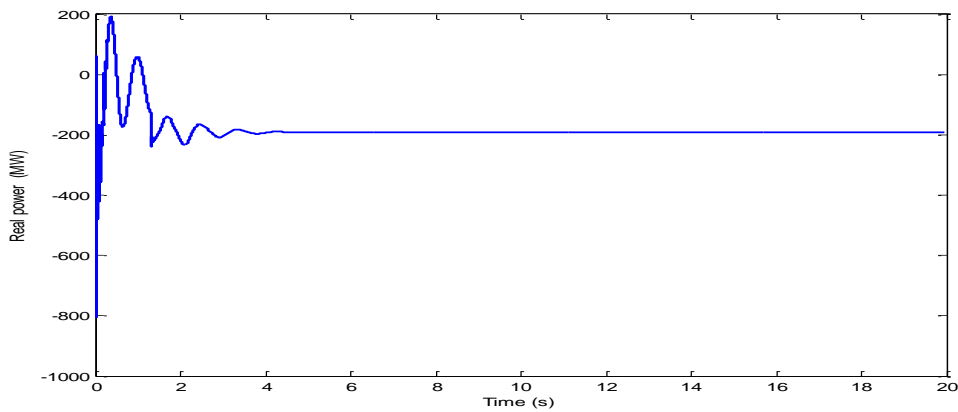

Figure 6.16 The oscillations in real power under fault with multiple PSS

Figure 6.16 shows the robust damping of inter area oscillations between two areas, when fault disturbances applied (0.1 - 0.2 sec), we can see the oscillation in the real power wave where it increase suddenly 650 MW from (-450 MW - 200 MW), at this moment the controllers will start to damp this oscillation and when the wave reach 4.2 sec the controllers will make those oscillation to be zero and the load will reach - 190 MW with no oscillations and the system will be stable.

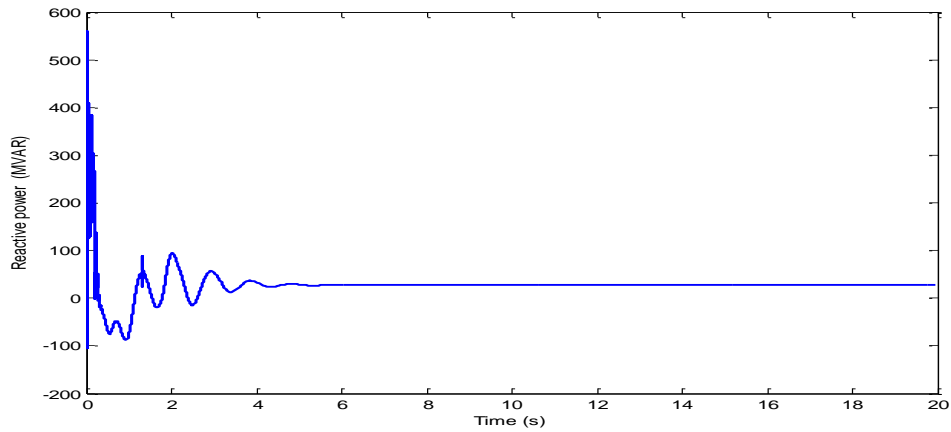

Figure 6.17 The oscillations in reactive power under fault with multiple PSS

The effect of the fault occurs clearly on reactive power where it changes rapidly about 500 MVAR after fallout from (400 -100 MVAR), and when the controllers work, these oscillations will damp until making these oscillations in zero value and the magnitude of the reactive power reach 40 MVAR with no oscillations at time 5.5 sec as shown in Figure 6.17.

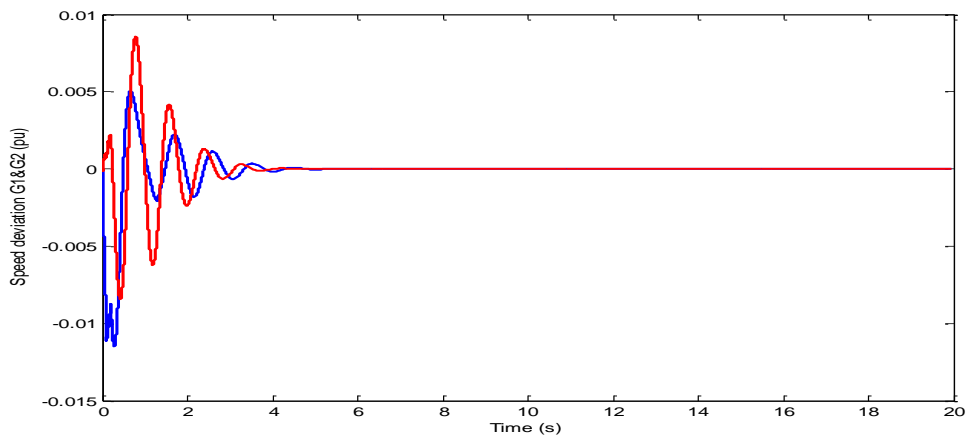

Figure 6.18 The speed deviation of rotors under fault with multiple PSS of G#1 (blue), G#2 (red)

The speed deviation also effect by fault, the speed of G1 change in range -0.005 to 0.013 (pu), whereas G2 changing in range -0.006 to 0.0085 (pu) after fault and these oscillations will damp rapidly when the controllers start running and at time 4.5 sec the oscillation will damp quickly and it became zero and stay in that value until 20 sec as shown in Figure 6.18.

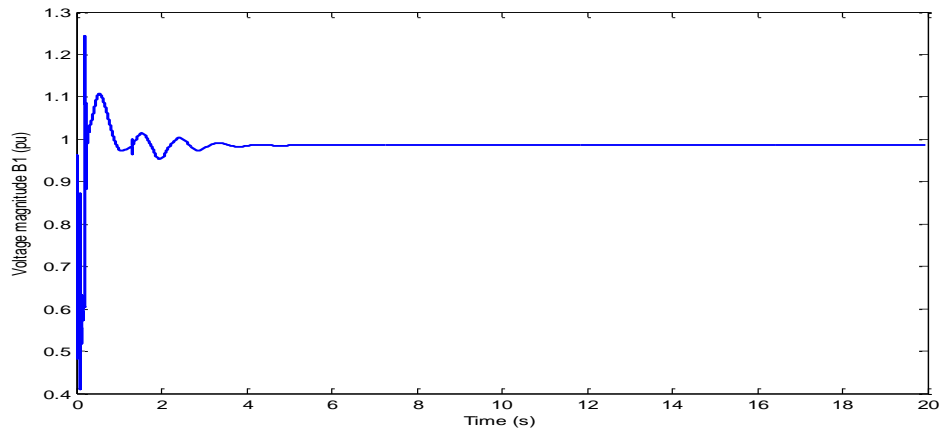

Figure 6.19 The voltage magnitude of bus 1 under fault with multiple PSS

From Figure 6.19 we can see the change in voltage magnitude of bus1 from 0.60 to 1.125 (pu), they will appear in a rapid way after a fault and the oscillation occur in the wave and it reaches the maximum value at time 0.5 sec and it will damp gradually to zero when the time reaches 4.5 sec and it stays in stable case until the time be 20 sec.

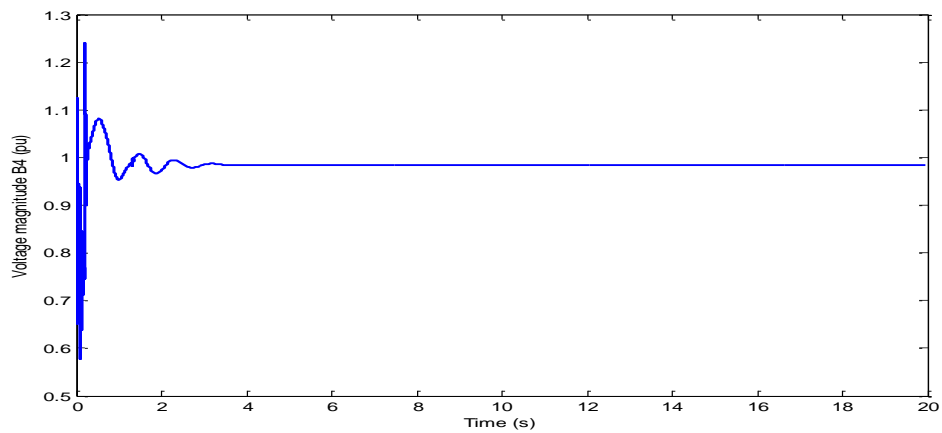

Figure 6.20 The voltage's magnitude of bus 4 under fault with multiple PSS

The voltage magnitude of bus 4, it also effected by the oscillations in the system and it will change in range 0.70 to 1.125 (pu), and damping rapidly when the time reach 4 sec and will stay in stable state to 20sec as shown in Figure 6.20.

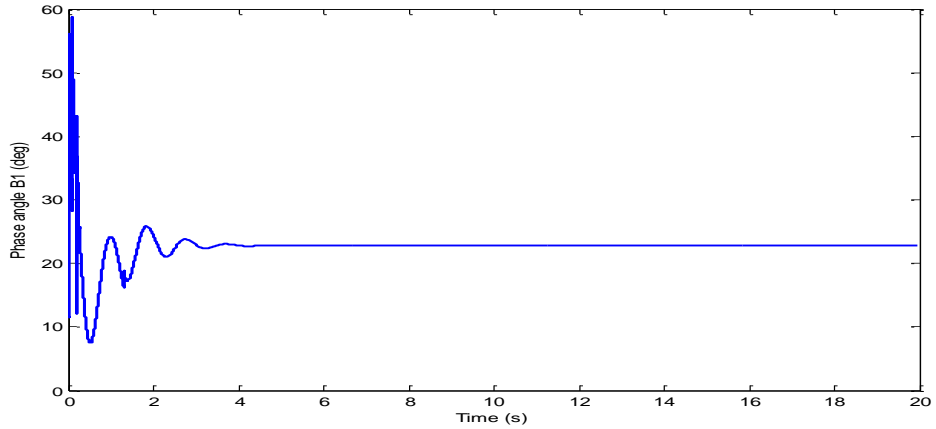

Figure 6.21 The voltage phase angle of bus 1 under fault with multiple PSS

It can illustrate from the Figure 6.21 the effect of fault occurring in clearly after 0.1 sec the time of fault starting and changing the phase angle wave suddenly where it reach 32° (from 40 to 8 degree) and this oscillation and distortion in the wave shape will correct and damp immediately and it became zero at 4 sec and continue in zero value until reach the end of iteration and the phase angle fix about 24°.

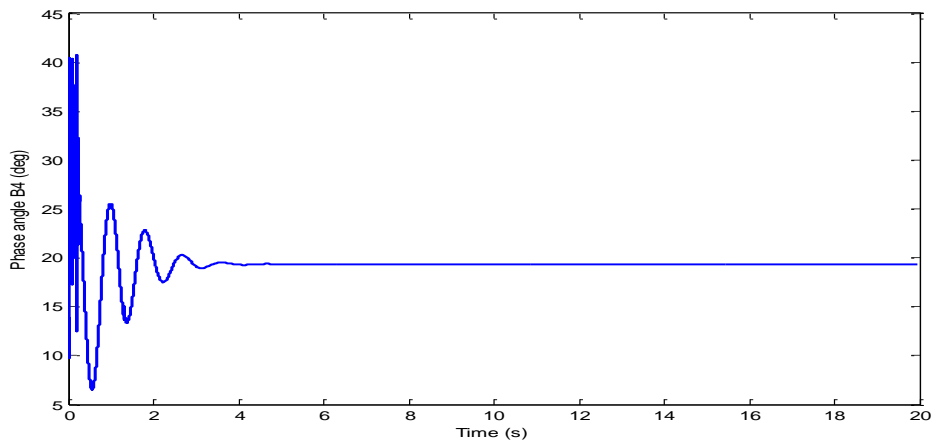

Figure 6.22 the voltage's phase angle of bus 4 under fault with multiple PSS

Voltage magnitude of bus 4 also has an oscillation after fault where it change from 41° to 7° and it damp in rapid way and it fix at 18° when the time be 4.5 sec to 20sec the point of end of optimization process as shown in Figure 6.22.

### 6.3.4 Case study 4: Simulation results with 0.1-0.3sec fault

The second robustness check we used the fault duration (0.1- 0.3sec) (Phase A - Ground fault). We can see the robust damping of oscillations in figures which related to real and reactive power, speed deviation, voltage magnitudes and phase angles for buses 1 and 4 of transmission line.

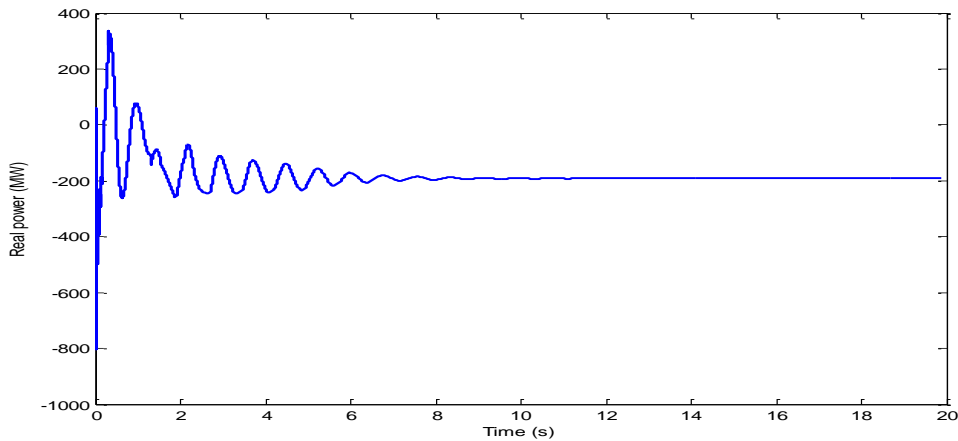

Figure 6. 23 The oscillations in real power under fault with multiple PSS

Figure 6.23 shows the robust damping of inter area oscillations, when fault applied (0.1 - 0.3 sec), we can see the oscillation in the real power wave where it increase rapidly (-450 - 300 MW), at this moment the damping controller will start to damp this oscillations until it reach 9 sec the controllers will make those oscillation to be zero and the load will reach 40 MW with no oscillations and the system will be stable after 9 sec and it will continue in stable state until 20 sec.

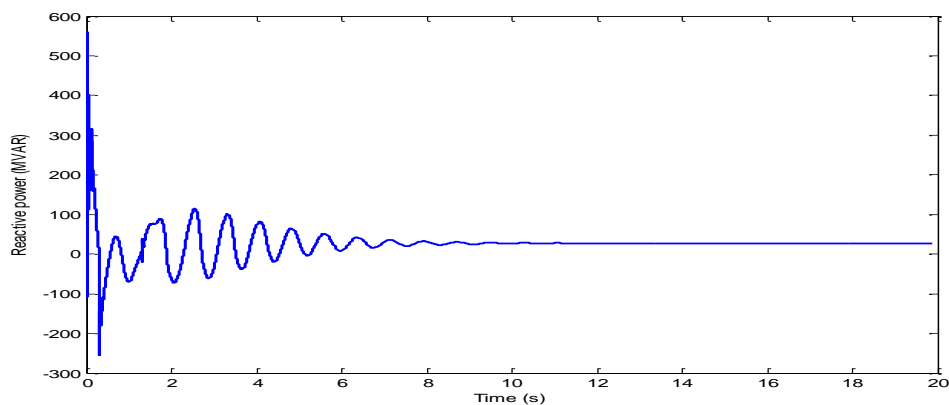

Figure 6.24 The oscillations in reactive power under fault with multiple PSS

The effect of the fault is appear in clear style on reactive power where it change suddenly after fault from about 650 MVAR, and after the controllers work, these oscillation will damp in fast way until making these oscillation in zero value and the magnitude of the reactive power reach 20 MVAR with no oscillations when the time reach 9 sec and these oscillations stile in zero value and this results guide us to get a stable system with no oscillations as shown in Figure 6. 24.

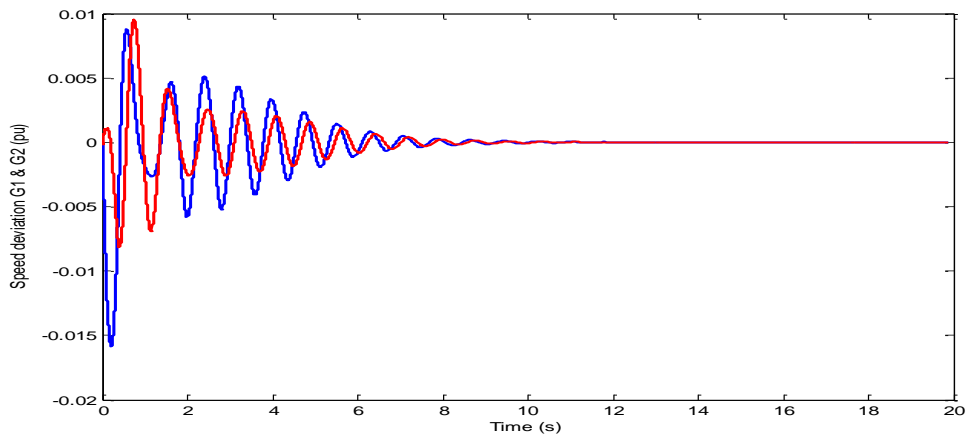

Figure 6.25 The speed deviation of rotors under fault with multiple PSS of G#1 (blue), G#2 (red)

The speed deviation also effect by fault appearing in transmission line, the speed of G1 change in range -0.016 to 0.009 (pu), whereas G2 changing in range -0.006 to 0.0095 (pu) after fault and these oscillations will damp in fast method when the controllers start running and at time 9 sec the oscillation will damp quickly and it became zero and stay in that value until 20 sec as shown in Figure 6.25.

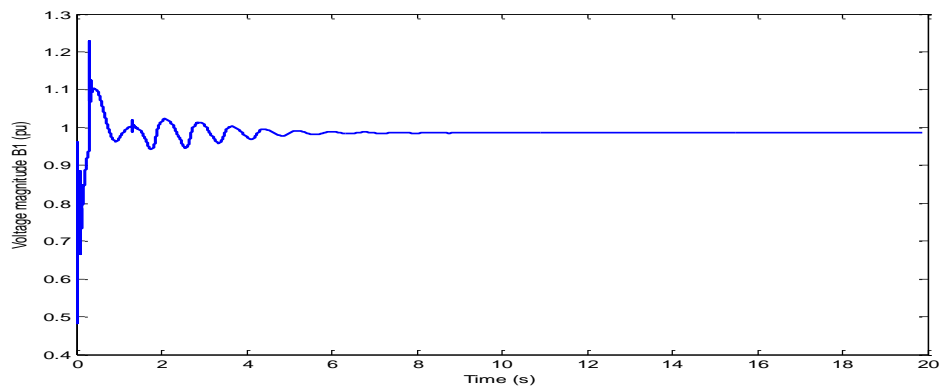

Figure 6.26 The voltage's magnitude of bus 1 under fault with multiple PSS

We can see in Figure 6.26: From 0.65 to 1.122 (pu), the voltage magnitude of bus1 will change in fast way after fault and the oscillation occur in the wave and it reach the maximum value at time 0.5 sec and it will damp gradually to zero when the time reach 7 sec and it stay in stable case until the time be 20 sec.

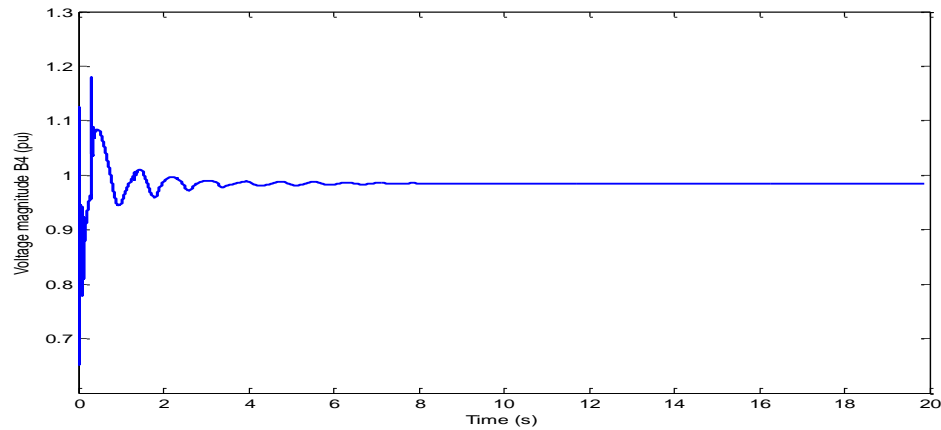

Figure 6.27 The voltage's magnitude of bus 4 under fault with multiple PSS

The same case of the voltage of bus 4, it also effect by the appearing of oscillation in the line and it will change in the range 0.77 to 1.19 (pu), and it will damp in rapid way when the time reaches 4 sec and will stay in stable state to 20sec as shown in Figure 6.27.

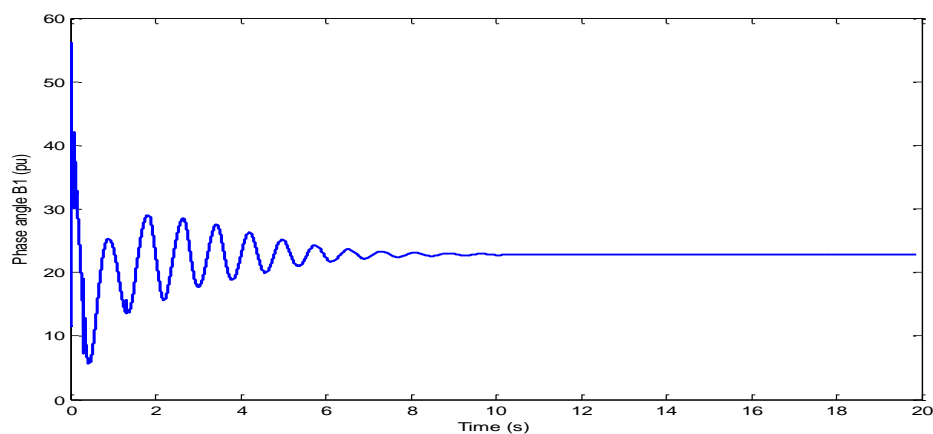

Figure 6.28 The voltage phase angle of bus 1 under fault with multiple PSS

It can be illustrate from the Figure 6.28 of voltage's phase angle of bus1 the effect of fault appearing in clearly after 0.1 sec the time of fault starting and changing the phase angle wave suddenly where it reach  $34^\circ$  (from 42 to 6 degree) and this

oscillation and distortion in the wave shape will correct and damp immediately and it became zero at 9 sec and continue in zero value until reach the end of iteration and the phase angle fixes about  $24^\circ$ .

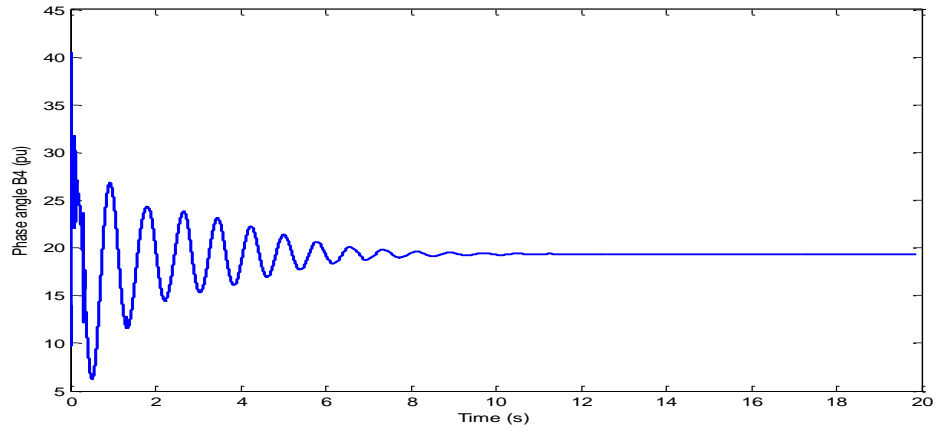

Figure 6.29 the voltage phase angle of bus 4 with multiple PSS

The voltage magnitude of bus 4 also has an oscillation after fault where it changes from  $32^\circ$  to  $6^\circ$  and its damp in a rapid way and it fixed at  $18^\circ$  when the time is 10Sec to 20Sec the end of simulation time as shown in Figure 6.29.



## CHAPTER 7

### CONCLUSION AND SUGGESTIONS FOR FUTURE WORK

#### 7.1 Introduction

From the simulation results that the coordination between UPFC and multi PSS has been executed to damp the oscillations of multi-machine power system, in order to improve the stability of the power system. The Combination way of Power System Stabilizer and unified power flow controller not only reduces the system oscillation, but also reduces the oscillations present in the real & Reactive power & phase voltage.

Through the results obtained, the following conclusions can be made:

- Designing UPFC based controllers for damping power system oscillations has been presented. It preserves the constant of power flow under fault, this work focuses on multiple PSS and UPFC damping controller design and their contributions in damping the system oscillations during contrary conditions. In this thesis, during the simulation studies the position of UPFC is kept constant in the middle distance between two areas. The simulation studies revealed that oscillations present after the occurrence of fault are greatly reduced after PSS and UPFC coordination.
- Coordination between the controllers is very important process in order to get the excellent performance and discussing the importance of coordination style between unified power flow controller and power system stabilizer via using an intelligent optimization technique which called particle swarm optimization PSO for making this coordination, this algorithm has an advantages like easy to complete as well as it need a few parameters for optimization and adjusting and also the ability to implement in different regions. The 17 parameters used to do this coordination to reach the wanted goal by solving the problems, where each bird (particle) is

correspond one individual solution of one problem in the fitness value is determined by index performance. PSS is used to damp the electromechanical oscillations and improve the dynamic stability of the power system, whereas UPFC is used to optimize and control the power flow in transmission line as well to damp the oscillations which occur in the line.

III) Four different case studies, simulation work and figures which related to real power, reactive power, speed deviation, phase angle for two buses and voltage magnitude also for 2 buses, it shows the figures from the first case study where uncoordinated design is used and the big effect of oscillation appears in the line and this oscillation remains with the waves from zero time until 20sec and the system is unstable system for all time duration. And when applied a second case study; coordinated design 2PSS with UPFC it can be shown the fast damping of these oscillations that occurred after a fault and it can illustrate the oscillation when it became a zero value and it's still in zero magnitude until the end of the optimization process.

- In the third case study a double phase to ground fault is applied, this case will check the robustness of model to damp inter area oscillations and the excellent damping of the oscillations which occurred because of the double fault will take a time duration more than one phase fault. Another robustness test is the fourth case study were used the fault duration 200 msec from 0.1 to 0.3sec and in this test it can show the robustness of model to damp these oscillations in rapid and good way and makes the oscillations in zero magnitude and get the stable system.

### **7.3 Suggestions for Future Work**

The future work of this work can extend to design:

- 1- Simulation model using another type of controllers from FACTS devices with multiple PSS using PSO.
- 2- Simulation model to improve power system stability using multiple PSS with another type of controller from FACTS devices using another intelligent technique such as Genetic Algorithm, Fuzzy-Neural,...etc.
- 3- Simulation model to enhance the stability of power system using UPFC with PSS using Genetic Algorithm as an intelligent technique.

## REFERENCES

- [1] Kundur, P. (1994). Power system stability and control (Vol. 7).
- [2] Padiyar, K. R. (2007). FACTS controllers in power transmission and distribution. New Age International.
- [3] Kumar, S. S. (2013). Co-ordinated Design of PSS and TCSC Damping Controllers in Multi-machine Power System using PSO (Doctoral dissertation, National Institute of Technology Rourkela).
- [4] Eslami, M., Shareef, H., & Mohamed, A. (2012, October). Coordinated design of unified power flow controller and power system stabilizer to enhance power system stability. In *Power System Technology (POWERCON), 2012 IEEE International Conference on* (pp. 1-6). IEEE.
- [5] Messina, A. R., & Nayebzadeh, M. (1999). Analytical investigation of the use of static VAR compensators to aid damping of inter-area oscillations.. *International Journal of Electrical Power & Energy Systems*, 21(3), 199-210.
- [6] Fan, L., Feliachi, A., & Schoder, K. (2002). Selection and design of a TCSC control signal in damping power system inter-area oscillations for multiple operating conditions. *Electric Power Systems Research*, 62 (2), 127-137.
- [7] Moris, S., Dash, P. K., Basu, K. P., & Sharaf, A. M. (2003). UPFC controller design for power system stabilization with improved genetic algorithm. In *Industrial Electronics Society, 2003. IECON'03. The 29th Annual Conference of the IEEE*, 2, pp. 1540-1545).
- [8] Fang, W., & Ngan, H. W. (2003). Enhancing small signal power system stability by coordinating unified power flow controller with power system stabilizer. *Electric Power Systems Research*, 65(2), 91-99.
- [9] Koyanagi, K., Yokoyama, R., Lee, K. Y., & Liu, C. (2004). PSS design for damping of inter-area power oscillations by coherency-based equivalent model. *International journal of electrical power and energy systems*, 26(7), 539-548.
- [10] Kumar, M. K., Sankaraiah, M., & Reddy, S. S. (2013). Mitigation of oscillations in power system by using UPFC and PSS.

- [11] Messina, A. R. (2006). Use of power system stabilizers for damping inter-area oscillations in the south systems of the Mexican electrical grid. *Electric power systems research*, 76(4), 169-179.
- [12] Zarghami, M., Crow, M. L., Jagannathan, S., & Liu, Y. (2008). Damping inter-area oscillations by UPFCs based on selected global measurements. In *Power and Energy Society General Meeting-Conversion and Delivery of Electrical Energy in the 21st Century, 2008 IEEE* (pp. 1-6). IEEE.
- [13] Gohari Sadr, V., Asadi, M. R., & Baghaee, H. R. (2008). UPFC controller design for power system stabilization with Particle-Swarm Optimization algorithm. In *Transmission and Distribution Conference and Exposition: Latin America, 2008 IEEE/PES* (pp. 1-7). IEEE.
- [14] Shayeghi, H., Shayanfar, H. A., Jalilzadeh, S., & Safari, A. (2009). A PSO based unified power flow controller for damping of power system oscillations, *Energy conversion and management*, 50(10), 2583-2592.
- [15] Talebi, N., & Akbarzadeh, A. (2011, May). Damping of Low Frequency Oscillations in power systems with neuro-fuzzy UPFC controller. In *Environment and Electrical Engineering (EEEIC), 2011 10th International Conference on* (pp. 1-4). IEEE.
- [16] Therattil, J. P., & Panda, P. C. (2011, December). Damping of power system oscillations using an advanced Unified Power Flow Controller. In *Power Electronics and Drive Systems (PEDS), 2011 IEEE Ninth International Conference on* (pp. 128-132). IEEE.
- [17] Bian, X. Y., Tse, C. T., Zhang, J. F., & Wang, K. W. (2011). Coordinated design of probabilistic PSS and SVC damping controllers. *International Journal of Electrical Power & Energy Systems*, 33(3), 445-452.
- [18] Narne, R., Panda, P. C., & Therattil, J. P. (2012). Damping of inter-area oscillations in power system using genetic optimization based coordinated PSS with FACTS stabilizers. In *2012 Annual IEEE India Conference (INDICON)*.
- [19] Hassan, L. H., Moghavvemi, M., Almurib, H. A., & Muttaqi, K. M. (2013, October). A coordinated design of PSSs and UPFC-based stabilizer using Genetic Algorithm. In *Industry Applications Society Annual Meeting, 2013 IEEE* (pp. 1-9). IEEE.
- [20] Esmaili, M. R., Hooshmand, R. A., Parastegari, M., Panah, P. G., & Azizkhani, S. (2013). New coordinated design of SVC and PSS for multi-machine power system using BF-PSO algorithm. *Procedia Technology*, 11, 65-74.
- [21] Hassan, L. H., Moghavvemi, M., Almurib, H. A., Muttaqi, K. M., & Ganapathy, V. G. (2014). Optimization of power system stabilizers using

participation factor and genetic algorithm. *International Journal of Electrical Power & Energy Systems*, 55, 668-679.

- [22] Hashmani, A. A. (2010). Damping of electromechanical oscillations in power systems using wide area control (*Doctoral dissertation, Duisburg, Essen, Univ., Diss*).
- [23] Kundur, P., Paserba, J., Ajjarapu, V., Andersson, G., Bose, A., Canizares, C., ... & Vittal, V. (2004). Definition and classification of power system stability IEEE/CIGRE joint task force on stability terms and definitions. *Power Systems, IEEE Transactions on*, 19(3), 1387-1401.
- [24] Zarghami, M. (2008). Inter-area oscillation damping in large scale power systems with unified power flow controllers. ProQuest.
- [25] Messina A. (2009). Inter area oscillation in power systems. *Springer Science business Media, LLC*.
- [26] Eldamaty, A. A. (2005). Damping interarea and torsional oscillations using FACTS devices (Doctoral dissertation, University of Saskatchewan Saskatoon).
- [27] Vural, A. M., & Tümay, M. (2007). Mathematical modeling and analysis of a unified power flow controller: A comparison of two approaches in power flow studies and effects of UPFC location. *International Journal of Electrical Power & Energy Systems*, 29 (8), 617-629.
- [28] Gyugyi, L. (1992, July). Unified power-flow control concept for flexible AC transmission systems. In *IEE proceedings C (generation, transmission and distribution)*, 139, pp. 323-331). IET Digital Library.
- [29] Smith, K. S., Ran, L., & Penman, J. (1997). Dynamic modelling of a unified power flow controller. *IEE Proceedings-Generation, Transmission and Distribution*, 144 (1), 7-12.
- [30] Padiyar, K. R., & Rao, K. U. (1999). Modeling and control of unified power flow controller for transient stability. *International Journal of Electrical Power & Energy Systems*, 21(1), 1-11.
- [31] Papic, I., Zunko, P., Povh, D., & Weinhold, M. (1997). Basic control of unified power flow controller. *Power Systems, IEEE Transactions on*, 12(4), 1734-1739.
- [32] Limyingcharoen, S., Annakkage, U. D., & Pahalawaththa, N. C. (1998). Effects of unified power flow controllers on transient stability.
- [33] In *Generation, Transmission and Distribution, IEE Proceedings*, 145, (2), pp. 182-188). IET.

- [34] Fuerte-Esquivel, C. R., & Acha, E. (1997). Unified power flow controller: a critical comparison of Newton–Raphson UPFC algorithms in power flow studies. *IEEE Proceedings-Generation, Transmission and Distribution*, 144(5), 437-444.
- [35] Liu, F., Yokoyama, R., Zhou, Y., & Wu, M. Study on Oscillation Damping Effects of Power System Stabilizer with Eigenvalue Analysis Method for the Stability of Power Systems.
- [36] Mitsubishi Electric. (2010). Power system stabilizer PSS.
- [37] Sreenivasachar, K. (2001). Unified power flow controller: Modeling, stability analysis, control strategy and control system design (Doctoral dissertation, University of Waterloo).
- [38] Sam, A. R., & Arul, P. (2013). Transient Stability Enhancement of Multi-machine Power System Using UPFC and SSSC. *International Journal of Innovative Technology and Exploring Engineering (IJITEE)*, 3(5).
- [39] Samuelsson, O. (1997). Power system damping-structural aspects of controlling active power. Lund University.
- [40] Hadi, S. P., Mochamed, R. F., & Imadudden, H. (2005). Multi objective function GA for modal OPTII\ IIAL control design between PSS and UPFC power oscillation damping coordination.
- [41] Sarkar, M. (2013). Load flow studies with UPFC power injection model/(Doctoral dissertation, National Institute of Technology Rourkela).
- [42] Kundur, P., Paserba, J., Ajjarapu, V., Andersson, G., Bose, A., Canizares, C., ... & Vittal, V. (2004). Definition and classification of power system stability IEEE/CIGRE joint task force on stability terms and definitions. *Power Systems, IEEE Transactions on*, 19(3), 1387-1401.
- [43] Kundur, P. (1994). Power system stability and control (Vol. 7). N. J. Balu, & M. G. Lauby (Eds.). New York: McGraw-hill.
- [44] Chompoobutrgool, Y., Vanfretti, L., & Ghandhari, M. (2011). Survey on power system stabilizers control and their prospective applications for power system damping using Synchrophasor-based wide-area systems. *European transactions on electrical power*, 21(8), 2098-2111.
- [45] Ravi, K., & Rajaram, M. (2013). Optimal location of FACTS devices using improved particle swarm optimization. *International Journal of Electrical Power & Energy Systems*, 49, 333-338.
- [46] Gazi, V., & Passino, K. M. (2011). Swarm stability and optimization. Springer Science & Business Media.

- [47] <http://mathworks.com/help/physmod/sps/examples/upfc-phasor-model.html/>
- [48] Kishore K., Sankaraiah M., Suresh S. (2013). Mitigation of oscillation in power system by using UPFC and PSS. *International Journal of Engineering research and applications*, 3, pp. 1065-1072.
- [49] Barış C., T. enes, S. emiroglu, E. sahin, PSO based Determination of SVC Control Parameters for Power System Transient Stability Improvement. *Akademik platform*.
- [50] Ali A., Hamed (2011). Damping of power system oscillations using UPFC based multipoint tuning AIPSO-SA algorithm.
- [51] Gmbh D. (2013). Power system stability on island networks, *Prepared for IRENA Workshop*, palau.
- [52] Ganesh K. Venayagamoorthy, (2005). Optimal Control Parameters for a UPFC in a Multi-machine Using PSO algorithm.
- [53] Shayeghi H., H.A. Shayanfar, S. Jalilzadeh, A. Safari (2009). A PSO based unified power flow controller for damping of power system oscillations, *Energy Conversion and Management*, 50, pp. 2583–2592.
- [54] Lee, D.C. (1992). Energy development and power of generation committee of power generation society, IEEE recommended practice for excitation system models for power system stability studies.
- [55] Rafiee Z., Ganjefar S., Meyabadi f. (2011). A New PSS Tuning Technique Using ICA and PSO Methods with the Fourier Transform. *EEE*, 1(1): 17-23.

## APPENDIX

### M-file of the PSO optimization routine

```
%% Tuning the model using Particle Swarm Optimization
%% Initialization
clear;
clc;
Ts=32.55e-6;    %sample time
n = 50 ;        % Size of the swarm " no of birds "
bird_setp = 50; % Maximum number of "birds steps"
dim = 17;       % Dimension of the problem
c2 = 1.2;       % social parameter
c1 = 0.12;      % cognitive parameter
w =0.9;        % inertia weight

Ub = [1.5 1.5 1.5 0.5 0.5 0.5 1.0 1.0 1.0 0.5 0.5 0.5 1.0 1.0 1.0 0.05 7];
Lb = [0 0 0 0 0 0 0 0 0 0 0 0 0 0 0 0.01 5];

Vmax = 1;
Vmin = -1;
y_fitness=[];
fitness=0*ones(1,bird_setp);
num_iteration =20; % Maximum number of iterations

% initializing the parameters

R1 = rand(dim, n); % selected numbers
R2 = rand(dim, n); % selected number
```



```

% initializing swarm and velocities and position %

Range = (Ub-Lb)*ones (1,n);
current_position = rand (dim,n).*Range + Lb'*ones(1,n);
velocity = rand(dim,n)*(Vmax-Vmin) + Vmin;
local_best_position = current_position ;

% start iteration

iter = 0 ;      % Iterations counter
while iter < num_iteration
iter = iter + 1;
%% Evaluate initial population
for i = 1:n

K=current_position(1,i);
Ka=current_position(2,i);
Kb=current_position(3,i);

T1=current_position(4,i);
T1a=current_position(5,i);
T1b=current_position(6,i);

T2=current_position(7,i);
T2a=current_position(8,i);
T2b=current_position(9,i);

T3=current_position(10,i);
T3a=current_position(11,i);
T3b=current_position(12,i)

```

```

T4=current_position(13,i);
T4a=current_position(14,i);
T4b=current_position(15,i);
Kp=current_position(16,i);
Ki=current_position(17,i);
[t_time,x_state,y1,y2]=sim('model',[0,num_iteration]);
y_out = y1+y2;

current_fitness(i) =y_out(end,1);
local_best_fitness = current_fitness ;
[global_best_fitness,g] = min(local_best_fitness) ;

% initialize global minimum

globl_best_position(:,i) = local_best_position(:,g) ;
if current_fitness(i) < local_best_fitness(i)
local_best_fitness(i) = current_fitness(i);
local_best_position(:,i) = current_position(:,i);
end
[current_global_best_fitness,g] = min(local_best_fitness);
fitness(iter)=current_global_best_fitness;
if current_global_best_fitness < global_best_fitness
global_best_fitness = current_global_best_fitness;

for i=1:n
globl_best_position(:,i) = local_best_position(:,g);
end
%%% Velocity Update %%%
velocity = w *velocity + c1*(R1.*(local_best_position-current_position)) +
c2*(R2.*(globl_best_position-current_position));

%%% swarm updating %%%
current_position = current_position + velocity;
for i = 1:n

```

```

for e=1:dim
if current_position(e,i)>Ub(e), current_position(e,i)=Ub(e); end
if current_position(e,i)<Lb(e), current_position(e,i)=Lb(e); end
y_fitness=[y_fitness,current_position(:,g)];
end
% ITEA changing according to fitness function
zbest=y_fitness(:,end)'
K=zbest(1);
Ka=zbest(2);
Kb=zbest(3);

T1=zbest(4);
T1a=zbest(5);
T1b=zbest(6);

T2=zbest(7);
T2a=zbest(8);
T2b=zbest(9);

T3=zbest(10);
T3a=zbest(11);
T3b=zbest(12);
T4=zbest(13);

T4a=zbest(14);
T4b=zbest(15);

Kp=zbest(16);
Ki=zbest(17);

[t_time,x_state,y_out]=sim('model',[0,num_iteration])

```