

A Government Phonology Analysis of Turkish Consonants

Dissertation submitted to the
Graduate Institute of Social Sciences
in partial fulfillment of the requirements for the degree of

Doctor of Philosophy

in

Linguistics

by

Ercan Balcı

Boğaziçi University

2006

The dissertation of Ercan Balcı

is approved by:

Dr. Ann Denwood _____

Prof. Dr. Eser Taylan _____

Prof. Dr. Ömer Demircan _____

Doç. Dr. Aslı Göksel _____

Yrd. Doç. Dr. Balkız Öztürk _____

July 2006

ACKNOWLEDGEMENTS

First of all, I would like to thank my advisor Dr. M. Ann Denwood for her support, advice and patience during this long and rocky dissertation process. Without her guidance, this dissertation could not have been completed. I am also grateful to her for introducing me to Government Phonology.

My thanks also go to Prof. Dr. Eser Taylan, Doç. Dr. Aslı Göksel and Yrd. Doç Dr. Balkız Öztürk for reading earlier versions of this thesis and giving me valuable feedback. I would like to express my special gratitude to Aslı Göksel for encouraging me to do my graduate work in Linguistics.

I am also thankful to my bosses Aslı Divriş and Esat Ören, along with my colleagues at Işık University for their understanding and support, which made it possible for me to do my Ph. D. while working full time.

I would also like to thank my subjects who helped me in the data collection stage.

Last, but not least, I am grateful to my beloved wife Susan for believing in me and for her constant support, patience and encouragement.

This dissertation is dedicated to my baby boy.

VITA

Place of birth: İstanbul

Date of birth: 16-01-1976

Colleges attended and degrees awarded:

2000-Present	Boğaziçi University, PhD. in Linguistics.
February 2002	INGED Teacher Training Workshop, Antalya, Curriculum Development Certificate.
1998-2000	Boğaziçi University, MA in Linguistics.
1994-1998	Boğaziçi University, BA in Foreign Language Teaching, Honors Degree.
July 1998 June 1998	Boğaziçi University, Linguistics Certificate, British Council, Istanbul, Teaching English for Young Learners Certificate.
August 1997	Anglo-World, Oxford, England. Certificate of Proficiency in English.

Professional appointments:

September 2005- present	Core Coordinator. EFL Department, Işık University.
February 2004-August 2005	Track 2 Coordinator. EFL Department, Işık University.
2000-present	English Instructor. EFL Department, Işık University,.
2001	Turkish Instructor. Boğaziçi University.
1998-2000	Teaching and Research Assistant. Boğaziçi University.

Publications:

Balcı, E. (2000). *The role of L1 parameters in second language acquisition: Turkish as a second language*. Unpublished M.A. thesis. Boğaziçi University.

ABSTRACT

A Government Phonology Analysis of Turkish Consonants

By

Ercan Balcı

The main topic of this dissertation is a detailed analysis of Turkish consonants in the framework of Government Phonology. In order to explain a number of phonological phenomena involving consonants, the elemental composition of consonants in Turkish is proposed for the first time. Stem-final and suffix-initial voicing alternations are discussed to find out the best way to represent voice. Fortition by the element H and spreading of H are proposed respectively to explain these voicing alternations in phonological expressions containing the ? element. In the light of the representation of voice, the representation of all consonants is based on the proposed analysis of voice contrasts. The governing relations in word-final consonant clusters are accounted for by inter-onset government. The elemental composition of consonants explains consonant clusters, the word-initial phenomenon and the word-final phenomenon. The role and the representation of palatalized consonants with the I element help us to account for the different ways of interpreting the first vowel of a word and to explain unexpected vowel harmony in the suffixes after word-final palatalized consonants. The data concerning word-final consonant clusters is drawn from TELL, and the data about the effect of palatalized consonants on neighboring nuclei is tested with 40 native speakers of Modern Turkish orally. This study provides elemental representations of Turkish consonants generated by a set of suggested Licensing Constraints on the combinations of elements and accounts for various phonological phenomena by referring to universal principles and parameters.

KISA ÖZET

Türkçe'deki Ünsüzlerin Yönetimsel Sesbilim İncelemesi

Ercan Balcı

Bu tezin temel konusu Türkçe'deki ünsüzlerin Yönetimsel Sesbilim modeli çerçevesi içinde incelenmesidir. Türkçe'deki ünsüzlerin birimsel yapısı ilk olarak bu çalışmada öne sürülmekte ve bu yapı bir çok sesbilimsel olguyu açıklamakta kullanılmaktadır. Ötümün hangi birimle gösterildiğini saptamak amacıyla kök-sonu ve sonek-başı ses değişimleri tartışılmaktadır. Yukarıdaki konumlardaki ? birimi içeren ünsüzlerdeki ses değişimleri sırasıyla “H birimi ile güçlendirme” ve “H-yayılmaları” aracılığıyla açıklanmaktadır. Ötümün birimsel yapısının belirlenmesi, diğer ünsüzlerin de birimsel yapısını açıklığa kavuşturmaktadır. Tümce-sonu ünsüz ikilemelerindeki yönetimsel ilişkiler “ünsüzler arası yönetim” ile açıklanmaktadır. Ünsüzlerin birimsel yapısı, tümce sonu ünsüz ikilemelerini, tümce başı olgusunu ve tümce sonu olgusunu açıklamaktadır. I birimi içeren “damaksıllaşmış” ünsüzlerin rolü ve birimsel yapısı, bize tümcenin ilk ünlüsünü seslendirmek için farklı yolları ve tümce-sonu damaksıllaşmış ünsüzlerin arkasından gelen soneklerdeki beklenmedik ünlü uyumunu açıklamakta yardımcı olmaktadır. Tümce-sonu ünsüz ikilemeleriyle ilgili bilgi TELL'den alınmıştır. Damaksıllaşmış ünsüzlerin çevrelerindeki ünlülere olan etkisi anadili Türkçe olan 40 tane konuşucu kullanılarak sözlü olarak test edilmiştir. Bu çalışma, burada önerilen bir grup birim birleşimleri üzerindeki “sınırlama”larla Türkçe'deki ünsüzlerin birimsel yapısını üretmekte ve böylece birçok sesbilimsel olguyu evrensel kurallara ve parametrelere dayanarak açıklamaktadır.

TABLE OF CONTENTS

	Page numbers
Abbreviations and Symbols	xi
CHAPTER 1 INTRODUCTION	
1.1 Introduction to the thesis	1-2
1.2 Overview of the theory	2-3
1.3 Outline of the thesis	4-5
CHAPTER 2 THEORETICAL BACKGROUND	
2.0. Introduction	6
2.1. Constituent Structure in GP	6-13
2.1.1 Constituent Government	9-10
2.1.2 Inter-constituent Government	11-13
2.2. Empty Category Principle	13-20
2.2.1 Parametric domain final p-licensing	14-15
2.2.2 Proper Government	15-16
2.2.3 Inter-onset Government	17-18
2.2.4 Magic Licensing	18-20
2.3 Morpho-phonology in GP	20-22
2.4 Element Theory	23-29
2.4.1 Headedness	25-27
2.4.2 Licensing Constraints	27-29
2.5. Complexity Condition	29-31

CHAPTER 3 DETERMINING THE ELEMENTAL COMPOSITION OF
TURKISH CONSONANTS

3.0. Introduction	32-34
3.1. Voicing Alternations	34-36
3.1.1. Stem-final voicing alternations	34-35
3.1.2. Suffix-initial voicing alternations	35-36
3.2. Previous studies	36-53
3.2.1. Feature-based Generative Grammar	36-38
3.2.2. Lexical Phonology	39-41
3.2.3. Optimality Theory	42-47
3.2.3.1. Stem-final voicing alternations	42-45
3.2.3.2. Suffix-initial voicing alternations	45-47
3.2.4. Government Phonology	47-53
3.2.4.1. Stem-final voicing alternations	48-51
3.2.4.2. Suffix-initial voicing alternations	51-53
3.3. Representation of stops and affricates	53-86
3.3.1. Stem-final voicing alternations	61-82
3.3.1.1. Morpho-phonology	63-70
3.3.1.2. Licensing power of a final silent N	70-73
3.3.1.3. Fortition in other languages	73-74
3.3.1.4. Fortition in Turkish	74-82
3.3.2. Suffix-initial voicing alternations	82-86
3.4. Representation of Fricatives	87-91
3.4.1. Voiced Fricatives	88-89
3.4.2. Voiceless Fricatives	89-91

3.5.Representation of Sonorants	91-94
3.5.1. Nasal sonorants	92-93
3.5.2. Non-nasal sonorants	93-94
3.6.Conclusion	94-96

CHAPTER 4 WORD-FINAL CONSONANT CLUSTERS IN TURKISH

4.0.Introduction	97-99
4.1.Empty nuclei trapped between two onsets	99-104
4.2. Governors and Governees	104-115
4.2.1. Acceptable order of consonants	107-110
4.2.2. Unacceptable order of consonants	110-115
4.3. Magic Licensing in word-final positions	115-120
4.4. Conclusion	121-122

CHAPTER 5 PALATALIZED CONSONANTS and THEIR INTERACTIONS

WITH VOWELS

5.0 Introduction	123-125
5.1 Previous Studies	126-129
5.2. Harmony of Turkish	129-141
5.2.1. Charette & Göksel (1996)	130-131
5.2.2. Charette & Göksel (1998)	132-136
5.2.3. Denwood (1997 a)	136-141
5.3. Palatalized Consonants	141-160
5.3.1. Pseudo-empty nucleus analysis	147-151
5.3.2. Word-initial phenomenon	151-155

5.3.3. Word-final phenomenon	156-160
5.4. U-licensing	161-168
5.4.1. Word-initial phenomenon	161-166
5.4.2. Word-final phenomenon	166-168
5.5. Conclusion	168-170
CHAPTER 6 CONCLUSION	
6.1. Summary of the Dissertation	171-176
6.2. Remaining problems and implications for further studies	176-178
REFERENCES	179-185

Abbreviations and Symbols

Abl.	Ablative
Acc.	Accusative
Ag.	Agentive
a-licensing	Autosegmental Licensing
Aor.	Aorist
concat	Concatenate
cont	Continuant
Dat.	Dative
Dim.	Diminutive
ECP	Empty Category Principle
Ger.	Gerundive
GP	Government Phonology
KhM	Khalkha Mongolian
KLV	Kaye, Lowenstamm and Vergneaud
Loc.	Locative
N	Nucleus
Nom.	Nominative
O	Onset
OT	Optimality Theory
Pl.	Plural
p-licensing	Prosodic Licensing
Poss.	Possessive
R	Rhyme
Subj.	Subjunctive

CHAPTER 1

INTRODUCTION

1.1. Aim of the Thesis

The aim of this dissertation is to account for a number of phonological issues in Turkish by understanding the whole elemental composition of consonants within the Government Phonology ¹ (henceforth GP) framework as proposed by Kaye, Lowenstamm & Vergnaud (henceforth KLV) (1990), Kaye (1990), Kaye (1995).

In this study, the elemental composition of consonants will be determined mainly by looking at stem-final and suffix-initial voicing alternations in Turkish. The analysis of voicing alternations will be used to discover the composition of Turkish consonants, which in turn, will be employed in accounting for other phonological phenomena related to the composition of consonants. The proposed elemental composition of consonants in Turkish will also enable us to claim a governing relationship between the consonants in word-final clusters. Finally, the relationships between consonants and vowels will be explained by accounting for two phenomena: i. the way the first nucleus in borrowed words with word-initial clusters is interpreted is explained by the elemental composition of consonants, and ii. the unexpected

¹ Since GP has diversified a lot since its beginning, GP in this thesis refers to the version of the theory as outlined during the 1990's mainly by Kaye, Charette, Lowenstamm and their students.

pattern of vowel harmony in suffixes is accounted for by the role palatalized consonants play.

Working out the elemental composition of Turkish consonants is hoped to be the contribution to the theory of GP in particular to the element theory of the Revised theory since the elemental composition of consonants have been proposed for only a few languages like Korean (Kim, 1996, Rhee, 1996), Khalkha Mongolian (Denwood, 1997 b, 2003) and Japanese (Nasukawa, 2000). The main contribution of the present study for Turkish phonology is the demonstration that certain phonological issues are best accounted for by determining the elemental composition of Turkish consonants. This is the first thesis on the representation of Turkish consonants in this framework.² The elemental composition of consonants in Turkish, which is proposed in this dissertation by using the tools of GP, is claimed to offer neat and simple explanations for voicing alternations, word-final consonant clusters and palatalization. Furthermore, these phonological issues which seem to be unrelated are explained by referring to the universal principles and parameters of GP.

1.2. Overview of the theory

GP is a phonological theory that accounts for phonological processes by recognizing universal government relations between constituents, and that proposes a small number of elements representing all the sounds and their properties in the world's languages. GP is fundamentally a non-derivational framework, that is, there is no mapping of one level of representation onto another. Instead, there are universal

² The first study on Turkish Phonology in GP was started in 1990s by Yılmaz Vural at SOAS, who passed away during his doctoral research.

principles defining well-formed phonological representations, and parametric choices concerning these principles, which are responsible for linguistic variation, rule out ungrammatical structures. That is to say, the way structures are represented follows universal principles, which means that the basic structure of a word is the same for all languages. However, some choices will have to be made in capturing different parameters which explain apparent differences among languages. GP differs from some other frameworks in having a limited number of possible structures organized according to universal principles.³

Before the advent of non-linear phonology, phonological processes were expressed in a flat structure based on rules with features used to specify sound segments. In linear phonology, a phonological event would be described in terms of linear segments where a segment would undergo a number of possible operations e.g. $A \rightarrow B/C_D$. Such a rule states that, the phonological segment A given in features, undergoes a phonological process (feature change, feature addition or deletion, etc.) such that it becomes a different segment B in the context of C and D.

In non-linear phonology like GP, however, a structure composed of different tiers where one segment may be associated with more than one position was proposed.⁴ The advantage of non-linear phonology is that it can not only account for phenomena like tone languages, e.g. Leben (1973) and Goldsmith (1990) which are difficult to explain in linear phonology, but also provides economical and universal accounts of tone, stress and vowel harmony.

³ The ideas of principles and parameters were taken from syntax.

⁴ Autosegmental phonology developed by Goldsmith proposes multi-tiered representation for the phonological structure of linguistic expressions, and this predates GP.

1.3. Outline of the thesis

In Chapter 2, the main principles of Government Phonology will be presented. The most relevant theoretical issues to the analysis made in this study like constituent structure, empty category principle, morpho-phonology, element theory and complexity condition are selected and discussed briefly.

In Chapter 3, the elemental composition of Turkish consonants will be proposed by discussing the voicing alternations of consonants, in both stem-final and suffix-initial position will be discussed. First, previous studies done on voicing alternations in different frameworks will be presented. Second, representation of voice will be discussed in the light of phonological processes in voicing alternations. These hypotheses will be extended to fricatives and sonorants in Turkish.

In Chapter 4, it will be claimed that stem-final consonant clusters are phonetically adjacent onsets separated by silent empty nuclei. The main focus will be on governing relationships of the onsets involved in a cluster. The elemental composition of Turkish consonants proposed in Chapter 3 will be argued to determine which consonants can be the first consonant of the cluster and which consonants can be the second. Additionally, the role of *s* and *ş* in word-final clusters will be discussed in a separate section since these clusters act differently from the other consonants in word-final clusters.

In Chapter 5, the interactions between palatalized consonants and vowels will be discussed in relation to interpretation of N_1 in borrowed words starting with word-initial consonant clusters and suffix-vowel harmony. The difference between palatal and palatalized consonants is captured in terms of representations of the element I. It will be claimed that N_1 in this context cannot be p-licensed in Turkish since it is not

truly empty, so it is vocalized depending on I-sharing and U-licensing, which is referred to as the “word-initial phenomenon” in this dissertation. The focus of the second part of this chapter is the “word-final phenomenon” which deals with the “unexpected” nature of vowel harmony in suffixes after palatalized consonants.

In Chapter 6, the hypotheses, assumptions and analyses of the three main chapters will be summarized. This chapter will also include the implications of the findings in this study for other phenomena and the points that are left for further studies.

CHAPTER 2

THEORETICAL BACKGROUND

2.0 Introduction

This chapter consists of five sub-sections which discuss the most salient principles of GP for the current study. First of all, principles which govern constituent structure in GP will be briefly discussed. Second, the Empty Category Principle will be discussed in detail by focusing on the different ways as to how an empty nucleus can be silenced. Third, the relationship between phonology and morphology is explained using GP terms. Then, elements forming consonants and vowels will be laid out. Finally, the complexity condition will be discussed since the elemental composition of consonants plays a role in the government relations between consonants.

2.1. Constituent Structure in GP

The aim of GP is to represent phonological phenomena following universal constraints on the organization of skeletal points. A skeletal point provides an intermediary timing slot linked to a constituent above and elements below. The series of positions is called the skeleton. The skeleton is part of a hierarchical structure known as constituent structure. Consider the following representation of

the constituent structure in GP:

(1) Constituents	O	N
Skeleton (Skeletal points)	x	x
Melody (Segments/Elements) ⁵	A	A

GP recognizes three constituents: onset, rhyme and nucleus, all of which can be either branching or non-branching. Unlike in other frameworks, onset does not only mean a syllable-initial consonant, it can be a consonant in word-final position too (although it does not occupy the final structural position). Nucleus refers to vowels. Nucleus and non-branching rhyme are the same constituents. When rhyme branches, it is headed by a nucleus and followed by an onset which is occupied by a consonant.

In GP, phonological processes apply only when they are necessary; hence there is no order of application. This is stated in the Minimalist Hypothesis (Kaye, 1995).

(2) Processes apply whenever the conditions that trigger them are satisfied.

It is parametrically determined whether the constituents, onset, nucleus and rhyme, may branch or not. These are subject to universal principles (Kaye, 1990), which are listed below:

⁵ Elements will be discussed in section 2.4.

- (3) i. Every nucleus can and must license a preceding onset.
 ii. Every onset must be licensed by a following nucleus.
 iii. Every constituent licenser must dominate a skeletal point.

These principles state that a nucleus without a skeletal point is ill-formed as in (4 c), whereas an onset may or may not have a skeletal point⁶, as illustrated in (4 a) and (4 b) respectively. The onset slot is always present, even though it may have no skeletal point, as in (4 b). The only permitted structures are shown in (4 a and b).

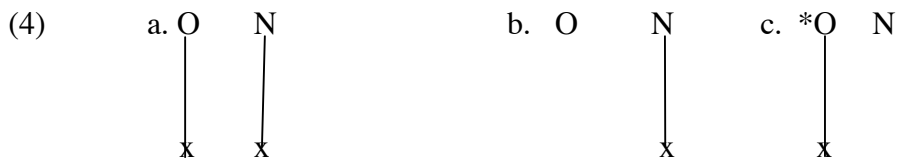

For example, in Turkish *bu* ‘this’, *o* ‘he/she/it’ are acceptable words but not **b*. That is the reason for stating that nuclei always have a skeletal point. When rhymes do not branch, they are not illustrated in the structural representation in this thesis.

In GP, representing syllabic structure is achieved by a series of governing relationships between the skeletal points associated with constituents. Relationships between skeletal points are formed in the lexicon and cannot be changed by phonological processes, stated formally as the Projection Principle (KLV, 1990).

- (5) Governing relations are defined at the level of lexical representation, and remain constant throughout a phonological process.

⁶ Some versions of GP use neither branching constituents nor skeletal points (among many Yoshida, 1993; Lowenstamm, 1996; Sheer, 2004).

This means that consonants and vowels must remain in the constituent they occupy. For example, a consonant occupying an onset remains in an onset. As a result of the Projection Principle, resyllabification is ruled out in GP.

2.1.1. Constituent Government

In GP, government relations determine acceptable phonological structures. There are two types of government in constituents in GP: constituent and interconstituent. When two units are sisters within a constituent such as onset, rhyme or nucleus, the relation is defined as constituent government. This government relationship is head-initial. The head of a rhyme is a nucleus as shown in (7). Government is subject to the following principles: i. only the head of a constituent may govern, and ii. only the nuclear head may govern a constituent head (Charette, 1990). Two principles regulating governing relations are defined below according to Kaye (1990):

(6) i. Strict Locality

No position must intervene between a governor and its governee.

ii. Strict Directionality

In a given governing domain, at the skeletal level, the direction of government is universally invariable.

Strict locality, together with strict directionality, rules out more than two branches. As can be seen in (7), skeletal points of branching onsets, rhymes and nuclei are in a constituent government relationship.

(7) Constituent Government

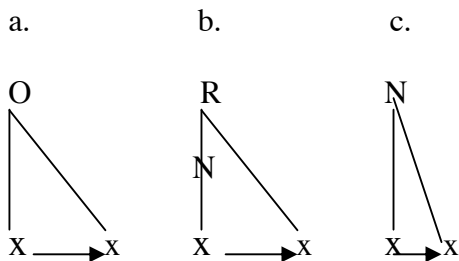

The bold skeletal points represent the heads of the structure that belong to one constituent.⁷ In (7 a), government takes place in the branching onset as in *br* in *brush*, which is considered to be a branching onset in English. In (7 b), the relationship between *i* and *l* in *milk* can be given as an example. (7 c) gives the representation of long vowels like [u:] in *food*.

2.1.2. Inter-constituent Government

When a governing relationship occurs between two different constituents, the relationship is called inter-constituent government, which is universally head-final. Consider the following illustration showing the context where inter-constituent government takes place:

(8) Inter-constituent Government

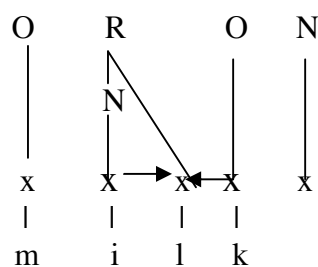

⁷ There are also 'substantive constraints', which means that the governing and governed positions must be occupied by suitable material.

As can be seen in (8), the onset following a branching rhyme must govern the branch of the rhyme, which is called the Coda Licensing Principle (which will be explained in more detail below). *k* in the following onset governs *l* in the branch of a rhyme. In the example above, we also observe constituent government between the branches of the rhyme *i* and *l*. However, codas must also be governed by the following onset as will be discussed below.

In (7 and 8), the bold skeletal points are heads of the constituents, and, thus, they are governors.⁸ According to constituent government, the nuclear point which is the head of the rhyme must govern a skeletal point of the rhymal complement. Therefore, the nuclear head must be strictly adjacent to the rhymal complement. Kaye (1990) formalizes this based on Strict Locality and Strict Directionality as the Binariness Theorem:

(9) Binariness Theorem

Syllabic constituents are maximally binary.

In GP, phonological positions need to be licensed in order to be present. Kaye (1990) states this principle as:

⁸ Governors will be discussed in the following section, where the governing relationship between two onsets silences a nucleus. Governors are found to be more complex than governees, and they are headed. However, in inter-constituent government, there is no empty nucleus to be licensed. Nasals cannot be governees in inter-onset government unless they are homorganic (KLV, 1990).

(10) Licensing Principle

All phonological positions, save one, must be licensed within a domain. The unlicensed position is the head of the domain.

Kaye (1990) argues that the coda is not a constituent by itself because it cannot branch. In other words, coda is not an independent category in GP. The term “coda” is also used in other frameworks, but it does not have to be governed by the following onset as it is the case in GP, where coda cannot exist in the word-final position. A domain final branching rhyme is ruled out following the Coda Licensing Principle (Kaye, 1990):

(11) Coda Licensing Principle

Post-nuclear rhymal positions must be licensed by the following onset.

The illustration in (8) shows the context where coda licensing principle defined formally in (11) takes place. O₂ licenses the post-nuclear position below:

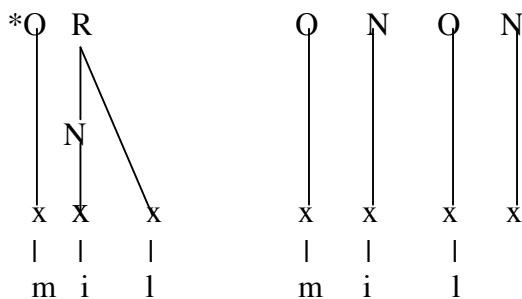
(12) a. *mill* [mil] b. *mill* [mil]

A consequence of coda licensing is that “closed syllables” cannot occur word finally as can be seen in (12 a). That is, a final consonant must occupy an onset followed by

a silent empty nucleus as in (12 b). In GP, it is ungrammatical to represent *mill* in a branching rhyme since there is no following onset to govern *l*; whereas, in *milk*, which is the representation given in (8) above, *k* can govern *l*, thus, allows the branching rhyme. Kaye (1990) points out that an onset only licenses a preceding coda if the onset is less sonorous than the preceding coda.

In this section, we have talked about universal government principles between skeletal points which are adjacent. In GP, there is also government at a higher projection. Onsets and nuclei which are not structurally adjacent in the skeletal tier can be adjacent at a higher projection to have a government relationship. Projection government is where phenomena like vowel harmony, stress and proper government take place.⁹ In government at a higher projection, the direction is not universal but it is parametric.

2.2. Empty Category Principle

In a framework which fits melody into an existing structure, there are sometimes empty positions. The existence of empty positions is a potential consequence of the top downwards approach to the one-to-many / many-to-one relationship between melody and structure. The interpretation or silence of empty positions does not occur randomly, but are controlled by application of universal principles (Kaye, 1990). In other frameworks, vowel harmony, metathesis, syncope and epenthesis are treated as different phenomena although they are all related to “empty positions”. GP analysis enables us to unify all these phenomena into a single

⁹ In this dissertation, proper government, I and U licensing from nuclei are represented over the constituents, while inter-onset government and I-licensing from I in an onset are represent below the structure for clarity.

universal principle (See Charette (1991) and Yoshida (1993) for a detailed discussion of existence of empty categories). The definition, principles and parameters of the Empty Category Principle (Kaye 1995) are provided below:

(13) The Phonological ECP

A prosodic (p)-licensed (empty) category receives no phonetic interpretation.

P-licensing takes place when:

i. Domain-final (empty) categories are p-licensed (parameterized) ON/OFF

(e.g. ON English, Turkish; OFF in Italian, Japanese)

ii. Properly governed (empty) nuclei are p-licensed.

α properly governs β if

i. α and β are adjacent on the relevant projection,

ii. α is not itself licensed, and

iii. No governing domain separates α from β .

iii. Empty nuclei within an inter-onset domain are p-licensed.

iv. Empty nuclei licensed by ‘Magic’ licensing are p-licensed.

There are four different ways an empty nucleus can be p-licensed to remain silent as stated in (13), which will be explained one by one below.

2.2.1. Parametric domain final p-licensing

The first type of p-licensing involves domain-final empty nuclei, which is a parametric difference between languages. In some languages like Italian, the parameter is switched OFF, which means that domain-final empty nuclei are not p-

licensed in that language; therefore, words must end in a vowel. However, in a language like Turkish, the parameter is switched ON, which means that domain final empty nuclei are parametrically p-licensed in this language, and therefore, words may end in consonants, which is the case.¹⁰

In GP, onsets and nuclei come in inseparable pairs, and all onsets must be licensed by a nucleus.¹¹ Since all word-final consonants must occupy an onset, if a nucleus always follows an onset, but the word phonetically ends in a consonant, then the last nucleus must be somehow silenced.

The fact that Turkish has parametrically p-licensed empty nuclei will be discussed in section 3.3.1.2, where special properties of the final silent nucleus are discussed.

2.2.2. Proper Government

The second way an empty nucleus can remain silent is by being p-licensed by an adjacent interpreted nucleus which properly governs it. If proper government fails to apply, the empty nucleus must be phonetically expressed. In GP, the direction of proper government is thought to be right to left.¹² There are three conditions on proper government which are: i. only an interpreted nucleus can properly govern an empty nucleus, ii. no intervening governing domain is allowable, and iii. nuclei must be adjacent at a nuclear projection. Consider the following examples from Moroccan Arabic (Kaye, 1990):

¹⁰ In Turkish, there are also words ending in phonetically interpreted domain final empty nuclei as in *arı* ‘bee’. For the analysis of such cases, see Denwood (1998).

¹¹ When there is a branching rhyme, onsets come in inseparable pairs with rhymes, but this does not weaken our claim here.

¹² Head-initial, right-to-left, proper government is proposed by Gibb (1992) and Rowicka (1999).

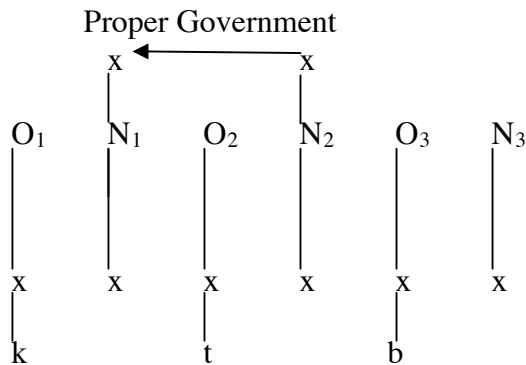
(14) a. [kt̪ib]¹³ ‘he wrote’

b. [k̪it̪bu:] ‘they wrote’

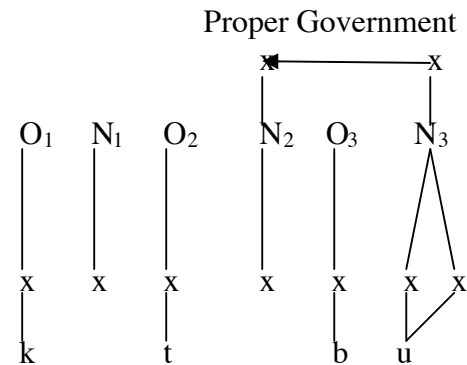

In (14 a), the final empty nucleus N_3 is silent by virtue of the fact that domain final empty nuclei are p-licensed by the parameter being switched ON, so it is uninterpreted. Being p-licensed itself, N_3 cannot properly govern N_2 , so N_2 is phonetically realized. Since it is phonetically interpreted, N_2 can properly govern N_1 . Therefore, N_1 may not be phonetically expressed. This government relation takes place at a supra-segmental level where nuclei are projected to be adjacent.

In (14 b), the final nucleus is branching and contains a long vowel [u:]; therefore, it can properly govern N_2 , allowing it to be silent. Properly governed N_2 cannot properly govern N_1 , which must be phonetically interpreted.

Proper government in Turkish will be considered in section 3.3.1.1, where the morpho-phonology of Turkish is being described in the GP model, and in section 4.2.2, where vowel-zero alternation is discussed.

¹³ [t̪] is the interpretation of an empty nucleus in Moroccan Arabic, and it is not necessarily the same in all languages.

2.2.3. Inter-onset Government

The third condition allowing an empty nucleus to remain silent is the inter-onset government relationship between two onsets. The elemental composition of consonants in these onsets determines which one is a good governor and which one is a good governee. The direction of inter-onset government is parametric unlike constituent or inter-constituent government. That is, both right-to-left and left-to-right directions are attested in different languages. For instance, the governing relationship between consonants in Khalkha Mongolian is right-to-left (Denwood, 1997 b). On the other hand, in Polish (Gussmann & Kaye, 1993), inter-onset government is left-to-right. When two consonants make a good inter-onset government domain, the empty nucleus is licensed to remain silent as formulated in Gussmann and Kaye (1993):

(15) Inter-onset licensing

Inter-onset government p-licenses an intervening nucleus between the onsets.

Let us consider an example from Khalkha Mongolian (Denwood, 1997 b), which shows an inter-onset government relationship between two word-final consonants.

(16) [xamt] ‘together’

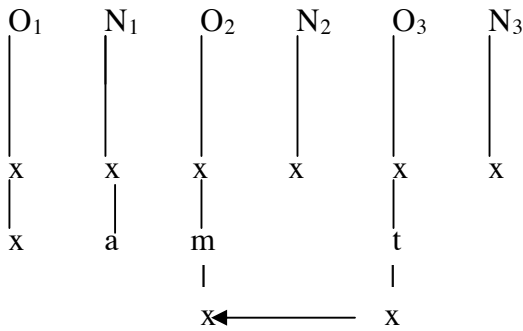

In (16), O₃ is a good governor since it dominates a headed expression,¹⁴ and O₂ is a good governee because it does not dominate a headed expression. This means that they can form an inter-onset government relationship, which allows N₂ to remain uninterpreted. Note that N₃ cannot properly govern N₂ since it is parametrically p-licensed; therefore, there is no other means to silence N₂.

The detailed nature of phonological expressions as governors and governees is the topic of Chapter 4 and will be fully discussed there.

2.2.4. Magic Licensing

There is one last kind of p-licensing, which is called Magic Licensing (Kaye, 1992). It applies in some languages, where a nucleus remains silent even though none of the other three conditions are satisfied. Kaye claims that in $s + C$ sequences, s as in *stop* occupies the branch of a rhyme followed by an onset. This means that $s + C$ sequences occupy the structure in (17 a) and not the one in (17 b).

¹⁴ Headedness of an element in the composition of a phonological expression, which is a characteristic of a good governor, will be discussed in section 2.4.1.

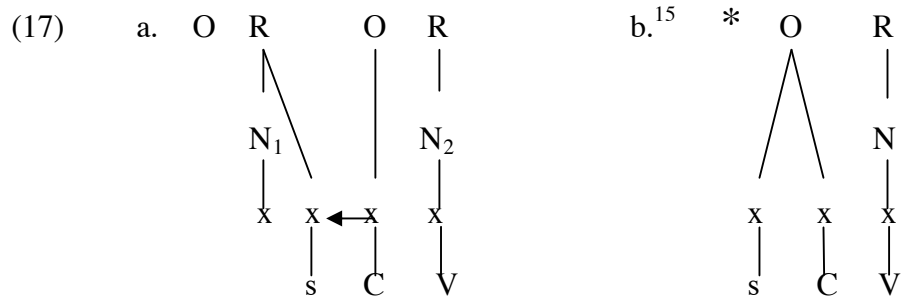

In (17 a), N_1 needs to be p-licensed, but N_2 cannot properly govern N_1 because there is a branching rhyme, whose branch needs to be governed by the following onset. Since a branching rhyme and an onset cluster form a governing domain, proper government cannot take place across it, there is no means to silence N_1 . The conditions for the licensing of N_1 here are not yet understood. The unavailability of a condition is therefore referred to as “Magic Licensing” (Kaye, 1992) (discussed in detail in section 4.3 in word-final positions and in section 5.4.3 in relation to the word-initial phenomenon). Kaye assumes that it is due to the special properties of s , which seem to be similar in many languages.

In (17 b), O_1 cannot be a good branching onset since constituent government is universally left-to-right, which means s needs to govern the following consonant. However, s is not a good governor of stops, for example, t in *stop*, because it is the governee of t as in *mist* and *cost*. Additionally, some word-initial clusters in English include three consonants where s precedes two consonants, which are always typical branching onsets, rather than just one, e.g. *splash*, *structure*. It should be noted that word-initial clusters with three consonants can only be seen when s is the first

¹⁵ This is not automatically ruled out. Branching onsets tend to be *br*, *bl*, *tr*, *gl* etc. type. However, s does not pattern with typical head of branching onsets *smooth*, *snow* etc. but not **bnow* or **gsmooth*. On the other hand, examples like *slow* can be analyzed as having a good word-initial branching onset, which patterns with *blow* or *glow*.

consonant in English. If $s + C$ clusters had the structure in (17 b), then words like *splash* would have three consonants occupying an initial branching onset. Consider the following diagram:

(18) *scream* [skri:m]

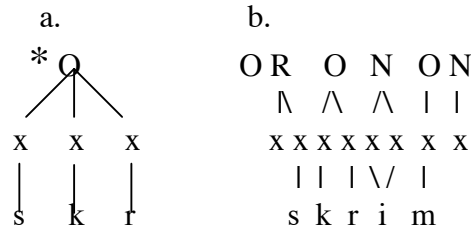

According to the Binariness Theorem as defined in (9), all constituents are maximally binary. It is not possible to consider s as a branch of the onset. Therefore, the structure in (18 a) is theoretically unacceptable. This structure is ruled out following Strict Directionality and Strict Adjacency principles as well. For examples like *scream*, the structure in (18 b) is used where O_2 is a branching onset.

2.3. Morpho-phonology in GP

Morphological structure falls into 2 types in the GP model: analytic and non-analytic, according to the visibility of a structure to phonology. There are two forms in analytic morphology, dependent and independent, which can be represented informally as: $[[A] B]$ ¹⁶ and $[[A] [B]]$; Non-analytic morphology is invisible to phonology and can be represented informally as $[A B]$. If words are composed of parts non-analytically, they come directly from the lexicon. According to Kaye (1995), the formal representations of types of morphology are given below:

¹⁶ In GP, we usually use square brackets to indicate domains.

- (19)i. analytic independent combination: $\Phi(\text{concat}(\Phi(A),\Phi(B)))$
 ii. analytic dependent combination: $\Phi(\text{concat}(\Phi(A),B))$
 iii. non-analytic combination: $\Phi(\text{concat}(A,B))$

(19 i) means “do phonology (Φ) on domain A, do phonology on domain B, put the two together (concatenate) and do phonology on the whole”. We can exemplify (19 i) by considering the compound *black-bird* in English, which has three domains; two internal, one external: [[bláck][b`ird]]. Phonology is applied to each domain. Both internal domains have p-licensed domain final empty nuclei and, when joined, *black* gets main stress, and *bird* gets secondary stress.

(19 ii) can be interpreted as “do phonology on domain A, combine it with B and do phonology on the whole”. In other words, B does not form a separate domain on its own. In (19 ii), there are two domains as in *look-ed* [[look]ed]. We first apply phonology on *look*, and then phonology is applied to the concatenated form with the suffix.

(19 iii) can be defined as “put A and B together and do phonology on the combination”. In English, for example, there are stem+suffix combinations like *parént-al*, in which the primary stress is on the second syllable and the vowel is different, whereas it is on the first one in *párent*. In this combination, there is only one domain [paréntal], and phonology is applied on the concatenated form.

According to the Principle of Strict Cyclicity (Kaye, 1995) adapted from Kean (1974), once phonology has been applied to an inner domain, the governing relations cannot be subsequently undone. Kean’s (1974) Principle of Strict Cyclicity is that “... on any cycle A no cyclic rule may apply to material within a previous

cycle B without making crucial use of material uniquely in A.” The adapted form of this principle is the basis of the theory of morpho-phonology in GP terms.

Adopting an analytic approach has some structural consequences as in the use of Reduction (Gussmann & Kaye, 1993). Reduction can only be used when a suffix analytically combines with a stem. According to this principle, when an empty nucleus is followed by an empty onset without a skeletal point, the nucleus and the onset are removed from any phonological representation where they occur. In the representations in this dissertation, when a p-licensed domain final empty nucleus is followed by a vowel-initial suffix, they are removed from the structure allowing the interaction between the nucleus in the suffix and stem-final onset. Consider the structure of a Turkish word followed by a suffix starting with a vowel:

(20) *pul-u* ‘stamp-Acc.’

Stem	Suffix
O ₁ N ₁ O ₂ N₂ O₃ N ₃	
[[x x x x]	x]
p u l	u

As can be seen in (20), the final silent nucleus N₂ and the suffix-initial pointless empty onset O₃ are removed from the structure, which makes O₂ and N₃ adjacent for any phonological processes. Reduction is represented by double strike-through above, which will be done in the rest of this study.

2.4. Element Theory

In GP terms, phonological expressions, i.e. consonants and vowels, are differentiated from each other in terms of being represented by a limited number of elements instead of using a large number of distinctive features. Elements are monovalent, unary atomic units of phonological description. Unlike feature based approaches, binary distinctive features are not used in GP. The use of elements is privative and asymmetric. In other words, an element is present in a given expression, if it is not, there is no minus property specified for that element. For example, when the element L is used to represent nasality, there is no other element used to represent non-nasality of other consonants. That is, there is no minus value of the element L such as -L. Some expressions may not contain any elements. Properties of a language need to be considered when we try to determine the elemental composition of its expressions. Phonological processes provide necessary tools to decide which elements combine to compose a phonological expression. It is argued by Cobb (1997) that with this small number of primitive elements in all permitted combinations, all the sounds of the world's languages can be represented.

Element Theory (KLV, 1990) plays a very important part in this thesis because voicing alternations, word-final clusters and interactions between consonants and vowels are all related to the elemental composition of Turkish consonants. In GP, there are several versions of Element Theory. Among many others, in Cobb (1997), Denwood (1997 a, 1997 b, 2002), Charette & Göksel (1996, 1998), Ploch (1996) and Kaye (2000), six elements are used in the representations of phonological expressions, as described below:

(21) A represents openness in vowels, coronality in consonants.

I represents height in vowels, palatality in consonants.

U represents roundness in vowels, labiality in consonants.

L represents low tone, slack vocal cords, voice consonants, nasality.

H represents high tone, stiff vocal cords, voicelessness in consonants, friction.

? the glottal stop¹⁷

There were originally more elements in GP (See Cobb, (1997) for discussion), and some researchers may still use others, as in Nasukawa (2000) and Brockhaus (1995, 1999) which will be discussed later. In this study, the elements provided in (21) will be used to represent Turkish phonological expressions.

In GP, only the elements A, I and U are sufficient to represent nuclear expressions.¹⁸ The vowel system of a language is therefore simpler than the consonant system, which involves combination of all elements. Different accounts of the composition of Turkish vowels have been proposed before (Charette & Göksel 1996, 1998, Denwood, 1997 a). Below is Denwood's (1997 a) account:

(22)	<i>a</i> (A)	<i>u</i> (U)	<i>i</i> (I)	<i>e</i> (A.I)
	<i>o</i> (A.U)	<i>ü</i> (U.I)	<i>ö</i> (A.U.I)	<i>ı</i> ()

¹⁷ Jensen (1994) argues that the stop element ? can be dispended; however, he does not have many followers.

¹⁸ Nasal vowels or tones are excluded because they are not relevant to the Turkish vowel system.

It should be pointed out that the vowel *ɪ* is empty, that is, it consists of no elements although it is phonetically interpreted.¹⁹ The representations of vowels in (22) will be used in Chapter 4 in terms of their relations with palatalized consonants.

Although the composition of Turkish vowels has been proposed before, there have not been any studies analyzing elemental composition of Turkish consonants in the theory of Government Phonology in available literature. The composition of consonants is more complicated than that of vowels because all 6 elements are involved in the compositions of consonants.

2.4.1. Headedness

An element can only perform in one of two roles: operator or head. Two or more elements can form a relationship in which they are both/all equal, that is, they are all operators. As exemplified in (22) above, Turkish vowels are represented in this thesis with one or more elements, all of which are operators. For example, *e* in Turkish has two operators represented as (A.I) according to Denwood (1997 a).

Besides having equal relationship, elements might have an asymmetric relation which can be expressed by headedness of one of its constituents over the others. That is, one element might stand as the head of the expression while other elements behave as operators.²⁰ The head of an expression licenses its operators and plays a role in the relationships between phonological expressions, e.g. vowel

¹⁹ Anderson and Jones (1974) who posit a triangular vowel space marked out by the three fundamental characteristics: I for frontness and palatal, U for labial, and A for low and open. In this representation, it was claimed for the first time that [ɪ] is composed of no elements. (Also Van der Hulst & Weijer (1991) use the element theory to explain Turkish vowel harmony.)

²⁰ Backley & Takahashi (1998) reject the notion of headship, and propose the notion of complement tier, which means that when an expression is licensed, the complement tier derives the predominance of its licensor element over other constituent elements.

harmony. An element is determined as a head by looking at the nature and behaviours of phonological expressions it is in. In this study, headedness is represented by underlining. For example, in some languages there are two types of *e*: while [e] headed by I can be represented as (A.I), [ɛ] headed by A can be represented as (I.A).

There are universal constraints on the combination of the elements into phonological expressions: i. there can be only one head per expression, and ii. no element may occur more than once in one expression (Kaye, 2001). Consider the representation of Turkish vowels using headed expressions: (Charette & Göksel's 1996)²¹

(23) *a* (A) *u* (U) *i* (I) *e* (I.A)
 o (A.U) *ü* (I.U) *ö* (A. I.U) *ɨ* ()

Headedness of a certain element serves three purposes:

- (24) i. to use the same element with two different functions
 ii. to make good governors if complexity is not sufficient accounting for government relations
 iii. to account for phonological processes

The first way headedness is used can be exemplified with the element L. It can be used as a head to represent voicing, and as an operator, representing for nasality.

²¹ The difference between Denwood and Charette & Göksel's analyses will be discussed in section 5.2.

Ploch (1996) uses L in the representation of *n* as operator, (A.ʔ.L), and as head in *d* (A.ʔ.L̲). The second way headedness is used will be apparent in Chapter 4, which is about the inter-onset government relationship between two phonetically adjacent final onsets. In the illustration (16) above, inter-onset government in Khalkha Mongolian can be seen. The third way we make use of headedness can be seen in the headedness of ʔ in plosives in sections 3.3.1.4 and 3.3.2 to account for stem-final and suffix-initial voicing alternations. Charette & Göksel (1996), for example, use headedness to explain vowel harmony in some Turkic languages.

2.4.2. Licensing Constraints

In addition to universal constraints on elements as mentioned above, there are also licensing constraints as proposed for Turkish by Charette & Göksel (1996, 1998), which will be discussed in section 5.2. According to Kaye (2001), licensing constraints, which are defined at L-structure (lexically), are language specific laws on phonological expressions. In GP, any phonological expression is grammatical unless specifically excluded by a licensing constraint. Licensing constraints are the constraints on the combinatorial properties of elements. In other words, they impose constraints on the role that elements can or must play in the composition of a phonological expression. There could be a constraint over all elements like ‘Phonological expressions must be headed’ or one element like ‘U must be head.’ Licensing Constraints cannot make reference to more than one element at a time. Consider the following licensing constraints of Finnish (Kaye, 2001):

- (25) i. All expressions are headed
 ii. U must be a head

Finnish vowel harmony follows naturally from the vowels generated by these licensing constraints. Finnish vowel harmony can be defined in such a way that if a nuclear expression in a phonological domain contains I as an operator, I must be present in every nuclear expression in the phonological domain.

One of the purposes of licensing constraints is to eliminate combinations which the language does not use. A total of nineteen different nuclear expressions (without making use of the possibility of an expression with no elements) can be derived by combining elements.

(26) a. Headless expressions

(A) (I) (A.U.I) (U.I)
 (A.I) (A.U) (U)

b. Headed expressions

(A) (A.I) (I.A) (I.U) (A.U) (I.A.U)
 (I) (U.I) (U.A)
 (U) (A.U.I) (I.U.A)

In Finnish, the first licensing constraint is “All expressions are headed”, which means the headless representations in (26 a) are not used. The second one is “U must be head”, which eliminates all the expressions where U is not a head. The circled

expressions below are the ones which are kept as a result of the suggested licensing constraints.

(27) Vowel system of Finnish

(A)	(A.ɪ)	(I.ɒ)	(I.ʊ)	(A.ʊ)	(I.A.ʊ)
(ɪ)	(U.ɪ)	(U.ɒ)			
(ʊ)	(A.U.ɪ)	(I.U.ɒ)			

As can be seen in (27), there are only 8 vowels in Finnish, which are generated by the licensing constraints in (25).

2.5. Complexity Condition

In traditional Generative Phonology, the construction of complex onsets and codas is guided by a sonority sequencing principle and requires onsets to rise in sonority toward the nucleus and codas to fall in sonority from the nucleus (Kenstowicz, 1994). The facts captured by the sonority sequencing principle are accounted by the elemental composition of consonants and the governing relations between them in GP (inter-onset government), which is stated as the Complexity Condition (KLV, 1990; Harris, 1990).

(28) Complexity Condition

Let α and β occupy the positions A and B respectively. Then if A governs B, α must be no more complex than β .

In GP, complexity is defined in terms of the number of elements forming a phonological expression. The complexity condition specifies governing relationships of consonants involved in an inter-onset government relationship. This was first devised for constituent and inter-constituent government, namely for branching onsets and branching rhymes (Kaye, 1990). The governor has to be equally or more complex than the governee in terms of the number of elements composing the phonological expression.

(29) [malmi] ‘leisure’

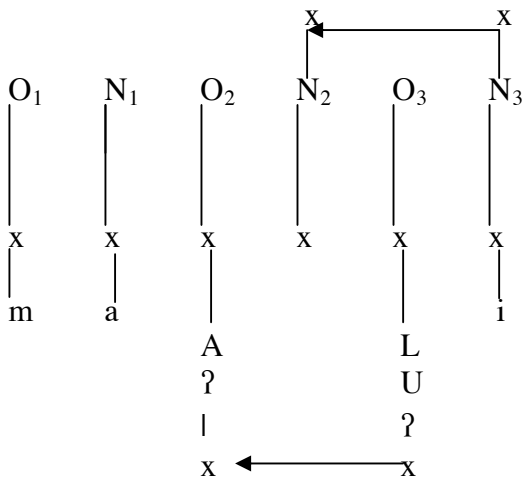

As can be seen in the illustration above, O₃ is more complex than O₂. Thus, the empty nucleus N₂ can remain silent. Note that in Korean for inter-onset government to work the empty position also has to be properly governed, and N₃ as an interpreted nucleus can properly govern N₂.

When headedness, which is another condition determining good governees as briefly discussed in the previous section, is not relevant, the phonological expression consisting of three elements can govern a phonological expression made up of two elements or equally complex one, e.g. three elements. Headed phonological

expressions are considered to be good governors even if they are less complex than their governees (Denwood, 1997 b). On the other hand, headed expressions cannot be good governees even if they are less complex than their governors. Consider the following examples showing how headedness accounts for inter-onset government in Khalkha Mongolian:

(30) [xamt] ‘together’

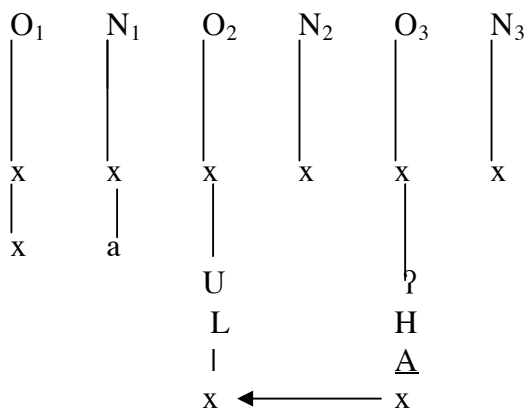

The A element is a head in O₃, thus it is a good governor, and O₂ is a good governee since it is headless. Since headedness is involved, complexity is not relevant in the example above.

Since there are some headless expressions in word-final positions in Turkish, complexity is a relevant principle for such cases. In order to account for word-final consonant clusters in Chapter 4, it will be seen that both headedness and complexity principles are relevant.

CHAPTER 3

DETERMINING THE ELEMENTAL COMPOSITION OF TURKISH CONSONANTS

3.0. Introduction

In this chapter, the elemental composition of consonants in Turkish in the framework of Government Phonology (GP) will be determined and discussed in detail. The elemental composition follows from the interactions of consonants with each other in phonological processes. It is not possible to determine the elemental composition without the analysis of the relevant phenomena, and the elemental composition helps us account for a number of phonological phenomena.

The following are the Turkish consonants²² except for the palatalized consonants whose elemental composition will be proposed in Chapter 5 in relationship to the word-initial and word-final phenomena. The composition of the following consonants will account for some phonological issues in Turkish like stem-final and suffix-initial voicing alternations.

²² Letters in italics show orthographic characters. The ones in square brackets ([]) represent International Phonetic Association (IPA) symbols. Orthographic characters are preferred for practical reasons, and IPA is resorted to when referring to pronunciation and when Turkish characters are different from IPA symbols. Square brackets are also used to represent distinctive features e.g. [-voice] in other frameworks as summarized in this chapter.

(1) a. Voiceless Consonants	b. Voiced Consonants
<i>p</i>	<i>b</i> <i>m</i>
<i>t</i>	<i>d</i> <i>n</i>
<i>k</i>	<i>g</i> [ŋ] ²³
<i>ç</i> [tʃ]	<i>c</i> [dʒ] <i>l</i>
<i>f</i>	<i>v</i> <i>r</i>
<i>s</i>	<i>z</i> <i>y</i> [j]
<i>ş</i> [ʃ]	<i>j</i> [ʒ]
<i>h</i>	

As can be seen in the table above, we have voiceless and voiced consonants in Turkish. There are more consonants in (1 b) since sonorants (which are spontaneously voiced) are included in this list. In this chapter, the elemental composition of these consonants will be discussed in three main categories depending on their properties and behavior: stops and affricates, fricatives and sonorants.

In this chapter, voicing alternations will be analyzed in order to try to determine the elemental composition of Turkish stops and affricates. The analysis of the elemental composition of stops and affricates in the light of stem-final and suffix-initial voicing alternations will provide a basis to analyze fricatives and sonorants. That is why, first these voicing alternations will be described. Then, different studies about voicing alternations from various theoretical frameworks are presented briefly. Third, the claim that representing voice in a certain way in Turkish has most explanatory power will be explained. Later, it will be shown how the proposed representations help us explain stem-final and suffix-initial voicing alternations in

²³ In GP, there are no allophones. The velar nasal is used before the velar stop, and it does not have an orthographic character in Turkish.

Turkish. Finally, the elemental composition of fricatives and sonorants will be discussed in separate sections before the summary of the chapter.

3.1. Voicing Alternations

Voicing alternations in Turkish occur in two contexts: stem-finally and suffix-initially. Examples of voicing alternations are given and briefly explained below.

3.1.1. Stem-final voicing alternations

In (2), we observe *p/b*, *k/g*, *t/d*, *ç/c* alternations in stem-final positions.²⁴ There are a number of words which undergo voicing alternations in stem-final positions.

(2) Voicing Alternation

	a.	b.	c.
<i>p/b</i> :	<i>kap - kab-ı</i> ‘container’	<i>turp - turp-u</i> ‘raddish’	<i>şarap - şarab-ı</i> ‘wine’
<i>k/g</i> :	-	<i>denk - deng-i</i> ‘equal’	-
<i>t/d</i> :	<i>tat - tad-ı</i> ‘flavor’	<i>kurt - kurd-u</i> ‘wolf’	<i>kanat - kanad-ı</i> ‘wing’
<i>ç/c</i> :	<i>taç - tac-ı</i> ‘crown’	<i>borç - borc-u</i> ‘debt’	<i>ataç - atac-ı</i> ‘paper clip’

We observe three columns of examples showing stem-final voicing alternations in stops and affricates: (2 a) consists of monosyllabic words; (2 b) has words ending in word-final consonant clusters; and in (2 c), alternations take place word-finally in

²⁴ *k* alternates with *g* only in *-nk* clusters preceded by *e*. *k* [k] generally alternates with *ğ*, \emptyset phonetically, in many other contexts e.g. *toprak - toprağ-ı* [topraɰ] ‘soil+Acc.’ as discussed in Sezer (1981) and Denwood (2002) among many others. In (2) and (3), the accusative suffix *-(y)ı* is attached

bisyllabic words. In all these examples, stem-final voiced plosives²⁵ occur only before suffix-initial vowels, not word-finally. That is to say, only vowel-initial suffixes appear to trigger voicing alternations. It makes no difference what consonant a suffix begins with, voiced or voiceless, alternating or non-alternating, the stem-final plosive will always be voiceless, as can be seen in *turp-ta* ‘raddish+Loc.’, *denk-ler* ‘equal+Pl.’, *cilt-çi* ‘book-binder’, *taç-sız* ‘crown+without’.

However, as can be seen in (3), stem-final plosives are not always voiced even if they are followed by a suffix starting with a vowel.

(3) No Voicing Alternation²⁶

	a.	b.	c.
<i>p/b:</i>	<i>top - top-u</i> ‘ball’	<i>harp - harp-ı</i> ‘musical instrument’ -	
<i>k/g:</i>	<i>ek - ek-i</i> ‘addition’	<i>fark - fark-ı</i> ‘difference’	<i>merak - merak-ı</i> ‘curiosity’
<i>t/d:</i>	<i>at - at-ı</i> ‘horse’	<i>kart - kart-ı</i> ‘card’	<i>halat - halat-ı</i> ‘rope’
<i>ç/c:</i>	<i>haç - haç-ı</i> ‘cross’	-	-

There are no bisyllabic words ending in a non-alternating *p* and *ç*, and there are no words with final clusters ending in a non-alternating *ç* as can be seen in (3 b and c).

to all the words which take different forms following vowel harmony. These examples will be discussed in section 3.3.1.4.

²⁵ The term “plosives” used here includes stops and the affricates *c* and *ç*. In 3.3.1.4, it will be claimed that these two categories of consonants behave the same way because of the element η in their composition.

²⁶ It has been noted in the literature that there are also words ending in a non-alternating voiced plosive in Turkish e.g. *ad - ad-ı* ‘name+Acc.’, *lig - lig-i* ‘league+Acc.’, *rab - rabb-i* ‘Lord+Acc.’, *hac - hacc-ı* ‘pilgrimage+Acc.’. Such examples will be discussed in section 3.3.1.4.

3.1.2. Suffix-initial voicing alternations

In (4) below, *k/g*, *t/d*, *ç/c* alternations are observed in suffix-initial position.²⁷

(4)	<i>k/g:</i>	<i>sal-gın</i>	‘epidemic’	<i>alın-gan</i>	‘over-sensitive’
		<i>şaş-kın</i>	‘confused’	<i>unut-kan</i>	‘forgetful’
	<i>t/d</i>	<i>ev-de</i>	‘home+Loc.’	<i>vatan-da</i>	‘country+Loc.’
		<i>raf-ta</i>	‘shelf+Loc.’	<i>çocuk-ta</i>	‘child+Loc.’
	<i>ç/c</i>	<i>av-cı</i>	‘hunter’	<i>anahtar-cı</i>	‘key maker’
		<i>tüp-çü</i>	‘gas seller’	<i>sanat-çı</i>	‘artist’

In the suffix-initial plosives given in (4), neither length nor the structure of the stem makes any difference to the voicing of the suffix initial plosive. After voiced stem-final consonants and vowels, a voiced suffix-initial plosive is used. After voiceless stem-final obstruents, a voiceless suffix-initial plosive is used. The only fricative in the suffix-initial position is *s*, which is invariant. No suffixes begin with the voiced fricatives **v* and **z*.

3.2. Previous studies

According to Blevins (2005), word-final devoicing of voiced obstruents occurs in many languages. She adds that in all languages with a voicing contrast, the contrast can be found before vowels. She claims that final-devoicing as a sound change has

²⁷ There are no suffixes starting with *p*, which can be a lexical gap, so there are no *p/b* alternations in suffix-initial positions. There are some “suffixes” starting with *k* which do not alternate, *-ki* ‘Poss.’ e.g. *onun-ki* ‘his/hers’.and *-ken* ‘while’ e.g. *konuş-ur-ken* ‘talk+Aor.+while’. They are considered clitics rather than suffixes since they do not harmonize with the stem.

occurred multiple times in the history of the world's languages in unrelated language families and in places where "contact-induced change" is not possible. "Devoicing" has been treated in many different approaches some of which will be discussed below:

3.2.1. Feature-based Generative Phonology

In traditional Generative Phonology, phonological processes are expressed as ordered linear rules in the form of $A \rightarrow B/C \text{---} D$. Foster (1969) analyzes all alternating consonants in Turkish as "underlyingly" voiced (Also, Lewis, 1967 and Underhill, 1976) These become voiceless word-finally, through a "devoicing rule". A devoicing rule is favored over a voicing rule since there are many words ending in non-alternating voiceless stops. The following rule applies to forms with underlying final voiced stops devoices them in a word-final position.

(5) Stem-final voicing alternation rule

$$[-\text{cont}] \rightarrow [-\text{voiced}] / \text{_____} \{ \#, +C \}$$

$[-\text{nasal}]$

The features $[-\text{cont}]$ and $[-\text{nasal}]$ define the class of consonants that undergoes this phonological process. The rule changing the feature $[-\text{voiced}]$ to $[-\text{voiced}]$ is applied word-finally and when a suffix-initial consonant follows the stem. For example, we have the underlying representation /kitab/ 'book', which is phonetically [kitap] and [kitap-tan] 'Abl.', as the rule in (5) renders the stem-final consonant voiceless word-finally and before a suffix starting with a consonant.

Erguvanlı-Taylan (unpublished class notes) agrees with Foster. She adds that if alternating forms underlyingly contain a voiced plosive in their phonemic representation (e.g. /kitab/ ‘book’, /kanad/ ‘wing’), a rule that devoices them in word-final position will give the desired phonetic forms. Those forms which do not undergo alternation will have a voiceless stop in their phonemic representation and hence the devoicing rule will not apply.

Suffix-initial consonant alternations in Turkish are claimed by Foster (1969) to be a property of suffix-initial plosives which agree in voicing with the last sound segment of the morpheme they are attached to, thus they are different from alternating stem-final plosives.

(6) Suffix-initial voicing alternation rule

[-cont] → [α voice] / [α voice] + _____
 [-nasal]

The rule in (6) can be interpreted as plosives in the suffix-initial position agree in voicing with the stem-final consonant or vowel. By using features, the group of consonants going through voicing alternation is specified, and by using positive and negative marking of the [voice] feature, voicing agreement is represented. The “+” sign means the alternation happens in the suffix-initial position.

The facts of voicing alternations are captured by phonological rules in traditional Generative Phonology by formulating rules, which are intended to account for language specific phenomena. They do not appeal to any universal principles or processes governing phonological events in languages.

3.2.2. Lexical Phonology

Lexical Phonology is an approach that accounts for the interactions of morphology and phonology in the word building process using ordered levels. There are lexical and post-lexical rules that apply to a word. The lexicon consisting of ordered levels plays a central, productive role in the theory for certain phonological or morphological processes (Kenstowicz, 1994).

In Lexical Phonology, morphology and phonology apply in harmony, which is subject to the sub-theory of level ordering and lexical stratification. Wiese's (1996) Lexical Phonology account is that [+voice] specification is delinked from any stops and affricates in the stem-final position. This delinking process results in voiceless consonants in word-final positions since the [-voice] specification can then be filled in by default.

Inkelas & Orgun (1995) analyze stem final voicing alternations in Turkish within Lexical Phonology. Consider the following examples:

- (7) a. *kalıp* *kalıp-ı* 'mold+Acc.'
 b. *devlet* *devlet-i* 'government+Acc.'
 c. *etüd* *etüd-ü* 'study+Acc.'

They claim that although binary voicing contrast can only be found on the surface, underlyingly there is a ternary contrast since there are plosives that alternate, there are plosives that are always voiceless, and there are plosives that are always voiced. They follow underspecification (Inkelas, 1994) in making a three way distinction. The assignment of [voice] is purely a structure filling process: plosives underlyingly

unspecified for [voice] surface as [+voice] in onset position and as [-voice] in coda position. The rules below neutralize the underlying three-way voicing contrast to a surface two-way contrast.

- (8) a. DEVOICING: Coda plosive → [-voice] (structure filling)
 b. VOICING: Onset plosive → [+voice] (structure filling)

They can be interpreted since voicing is determined at the phrase level, and hence is sensitive to surface syllable position. They also claim that the virtual non-existence of alternating final plosives in monosyllabic²⁸ roots may be attributed directly to the bi-moraic minimal size condition which blocks final consonant invisibility from applying. Inkelas & Orgun (1995) do not say anything about suffix-initial voicing alternations.

The question of which features are universally available for insertion into unspecified lexical entries has been explicitly raised in *Lexical Phonology* (Kiparsky 1985, 1998). This line of research, taken up most prominently by Archangeli, (1988) led to the discovery of features and feature values which show a high degree of inactivity and invisibility in phonological systems. Kiparsky (1985), and particularly Archangeli argued that this phonological inertness should be coded by non-specification of such features in underlying representations. However, no general principle for determining which features can be universally underspecified and under

²⁸ Inkelas & Orgun assume that devoicing applies cyclically, but root final plosives are protected from devoicing on the root cycle. When the consonant is non-final as a result of suffixation, it is directly syllabified into its surface position, acquiring the appropriate laryngeal specification. In monosyllabic roots, the final consonant is forced to syllabify on the root cycle by an independently needed, higher ranked bi-moraic minimal size condition, and devoices on the root cycle. A non-cyclic account would have to claim that the plosive in question is actually a coda in the output.

which conditions these underspecified features are inserted into the phonological derivations could be provided.

Inkelas (1994) (also Inkelas & Orgun, 1994) claims that the use of “underspecification” is the answer to the cases of voicing alternations observed in Turkish plosives. Let us look at the concrete examples as provided by her:

(9) a. kana/D/ ‘wing’ b. sana/t/ ‘art’ c. etü/d/ ‘study’

The stem-final stop in (9 a) is “unspecified” for the feature [voice] and hence represented in capitals, while the one in (9 b) is specified as [-voice], and the one in (9 c) is specified as [+voice]. In her account, underlying forms are neither marked nor unmarked, which is similar to neutralized consonants. In order to get the alternating forms correctly, such a grammar would prefer a voiced stop or affricate over a voiceless one in a coda position.

In order to account for the contrast between under-specified and specified stops, Inkelas (1995) claims that the underlying form should be determined by the revised “Lexicon Optimization”, which selects underspecification only in alternating structures and not in other contexts. That is to say, /kanaD/ ‘wing’ is selected as the input form for alternating stems, rather than /kanat/ or /kanad/ and, at the same time, selects /sanat/ ‘art’ or /etüd/ ‘study’ as the input for non-alternating ones.

In this approach, suffix-initial consonants are always underspecified. That is to say, *kaş-/D/a* ‘eye-brow+Loc.’ is realized as *kaş-ta* since *ş* is voiceless. /D/ is unspecified for voice, so it agrees with *ş* in voicing.

3.2.3. Optimality Theory

In Optimality Theory (henceforth OT) (McCarthy & Prince, 1993), voicing alternations are explained as “constraint-based” in line with “universal markedness constraints”. The main idea of OT is that the observed "surface" forms of language arise from the resolution of conflicts between grammatical constraints. Constraints can be grouped into two main types: faithfulness constraints and markedness constraints. A faithfulness constraint requires that the observed surface form (the output) matches the input form in some particular way. The input form is a hypothetical object that is typically generated by some simple rule. A markedness constraint imposes some requirement on the form.

3.2.3.1. Stem-final voicing alternations

Lombardi (2004) analyzes the voicing typology as derived through a tension between markedness of voicing and faithfulness to underlying specification of voice. Coda devoicing appears when faithfulness in the onset is stronger than markedness. She follows the concept of markedness of phonological segments, which states that voiced obstruents are marked, not voiceless ones. She proposes the following ranking:

(10) IDONSLAR, AGREE >> *LAR >> IDLAR,

According to (10), the constraints IDONSLAR “Onsets should be faithful to underlying voicing” and AGREE “Agree in voicing” have the highest rank which are

followed by *LAR, which means “do not be voiced”. Finally, the constraint IDLAR stating that “Be faithful to input voicing” has the lowest rank.

Grijzenhout (2000 b) discusses stem-final voicing alternations in German as exemplified below:

- | | | | |
|------|------------|----------|----------------------|
| (11) | a. hunde | - hun[t] | ‘dogs-dog’ |
| | b. diebe | - die[p] | ‘thieves- thief’ |
| | c. berge | - ber[k] | ‘mountains-mountain’ |
| | d. mau[z]e | - mau[s] | ‘mice – mouse’ |

German stem-final voicing alternations are similar to Turkish, except for the fact that in Turkish fricatives do not undergo voicing alternations. The following constraint represents the stem-final voicing alternation in German in the framework of OT.

- (12) Final Devoicing: *C[-sonorant]σ
 |
 [+voice]

(12) represents the constraint on voiced final obstruents by stating that it is not possible to have such a consonant (i.e. voiced obstruents) in syllable final positions. As a result of this final devoicing constraint, word-final obstruents are realized as voiceless.

Kallestinova (2004) proposes an OT analysis for Turkish voicing alternations to illustrate stem-final voicing alternations:

- | | | | |
|------|---------------|--------------|------------------|
| (13) | a. <i>kap</i> | <i>kab-ı</i> | ‘container+Acc.’ |
| | b. <i>at</i> | <i>at-ı</i> | ‘horse+Acc.’ |

c. *ad* *ad-ı* ‘name+Acc.’

She proposes that alternating stops are voiceless non-spread glottis, non-alternating voiceless plosives are voiceless spread glottis, and non-alternating voiced stops are voiced. She proposes the following ranking for Turkish stem-final voicing alternations:

(14) *voi/sg >>ID-IO_{root} >>*voice, *sg²⁹

The constraint *voi/sg is ranked higher than ID-IO_{root} to prevent outputs with voiced spread glottis stops, which do not exist in the language inventory. This ranking means that the highest rank constraint is that voiced alternating stops, non-spread glottis, cannot be voiced in word-final positions, and the lowest one is voiced non-alternating, spread glottis consonants are prohibited.

Beckman & Ringen (2004) analyze Turkish stem-final devoicing in the framework of OT following Kallestinova’s (2004) examples in (13) in a similar OT analysis. They propose the following constraints:

(15) [-voi] is [spread]: A voiceless stop must be [spread].

In order to derive the actual two-way contrast, a high-ranking constraint requiring that a stop be specified for some laryngeal feature is necessary.

²⁹*[spread glottis] *sg: [spread glottis] segments are prohibited. ID-IO (root): Correspondent input-output root segments have identical specifications for all features. *voi/sg: Voiced spread glottis stops are prohibited.

(16) SPECIFY [Lar]: Stops must be specified for a laryngeal feature.

They argue that the intervocalic voicing of laryngeally unspecified stops results in the voicing of underlyingly non-[spread] stops as in (13a). Stops that are underlyingly [spread] are always voiceless as in (13 b). Stops that are always voiced as in (13 c) are analyzed as underlyingly specified for [voice]. They claim that Turkish seems to necessitate the use of both [spread] and [voice] in underlying representations.

3.2.3.2. Suffix-initial voicing alternations

Grijzenhout (2000 a) discusses voicing alternations in suffix-initial positions in English and Dutch. Consider the examples taken from her study below:

(17) a. hugged [gd] kicked [kt]
 b. za/k/ + -/d/e [kt] ‘sink-sank’ to/b/+-/d/e [bd] ‘worry-worried’

In the examples above, the stops in the suffixes agree with the stem-final consonant in voicing, which is similar to Turkish. She claims that the following constraint captures the observations in English and Dutch examples.

(18) IDENTONSPWSTOP (voice): Plosives in onsets of prosodic words should have the same value for the feature [voice] as in the input.

Kallestinova (2004) gives the following data from Turkish to account for the suffix-initial voicing alternations in Turkish in the framework of OT.

- (19) a. *kap – kap-tan* ‘container+Abl.’
 b. *sap^{sg} - sap^{sg}-tan³⁰* ‘stem+Abl.’
 c. *ad – ad-dan* ‘name+Abl.’
 d. *masa – masa-dan* ‘table+Abl.’
 e. *kalem – kalem-den* ‘pen+Abl.’
 f. *ev – ev-den* ‘house+Abl.’

She assumes that the stops in these suffixes are underlyingly voiceless non-spread glottis. She proposes $\text{Share}_{(\text{voi})}$ constraint provided below to account for the examples in (19).

(20) $\text{Share}(\text{voice})$: Obstruents in clusters must share voice specifications.

In the following ranking representation, Kallestinova demonstrates that $\text{Share}_{(\text{voi})}$ must be ranked higher than $*\text{voice}$ ³¹:

(21) $\text{Share}(\text{voi}) \gg * \text{voice}$

Orgun (2004) also discusses suffix-initial voicing assimilations by giving following examples:

³⁰ sg means spread glottis, which is used to signal that the stem-final stop does not alternate.

- (22) a. *kanat – kanat-tan* ‘wing+Abl.’ *kantar – kantar-dan* ‘scale+Abl.’
 b. *çocuk – çocuk-ken* ‘child+while’ *zengin – zengin-ken* ‘rich+while’

In (22 a), it is observed that suffix-initial voicing assimilation takes place before devoicing which can be represented as (ASSIM-VOI) >> IDENT-VOI. When he considers (22 b), where there is no voicing assimilation, he modifies the ranking of the constraints as:

- (23) Ident-voi_{syllabified} >>ASSIM-VOI >> Ident-voi_{general}

In Optimality Theory, all constraints can be violated depending on ranking. Also ranking of these constraints can change depending on the phonological phenomena. If any constraint can be violated, the point of having constraints to account for phonological processes is difficult to understand. Additionally, although these constraints are claimed to be universal, they are devised to describe specific phenomena in a specific language.

3.2.4. Government Phonology

In the following sections, two studies done on voicing alternations in the framework of GP will be presented; first, Brockhaus’s (1999) (also in Brockhaus, 1995) account of German stem-final voicing alternations, and then Nasukawa’s (2000) analysis of Japanese suffix-initial voicing alternations. Both these works use a slightly different

³¹ *voice: Voiced obstruents are prohibited.

version of element theory from the one used here. The differences will be explained where relevant.

3.2.4.1. Stem-final voicing alternations

Brockhaus (1999) (also Brockhaus, 1995) discusses voicing alternations in German which occur only where the relevant obstruents occupy the last onset of the stem. Brockhaus represents voicedness by using the element L, instead of representing voicelessness by the element H.

Brockhaus claims that final “devoicing” consists of the depletion of a-licensing³² potential, which is a concept proposed by Harris (1992). The following illustration is given in Brockhaus (1999) to show the Licensing Inheritance relationships in a domain:

³² *Prosodic licensing and autosegmental (a) licensing (Harris, 1992)*

P-licensing sanctions the presence of positions at different levels of projection, ranging from the skeletal tier through successively higher domains at the level of the constituent, the foot, the word and so on throughout the prosodic hierarchy.

A-licensing determines the phonetic interpretability of a melody unit, the minimum requirement for which is association with a skeletal point.

A-licensing potential

The a-licensing potential of a skeletal position refers to its ability either to directly a-license a melodic expression or to confer a-licensing potential on another position.

Licensing Inheritance

A licensed position inherits its a-licensing potential from its licensor.

(24) *blieb* [bli:p] ‘stayed’

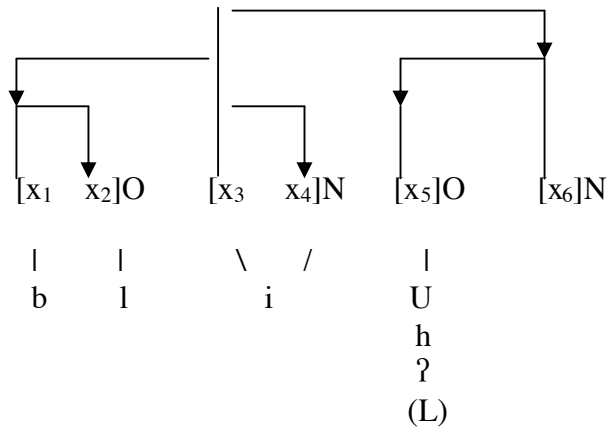

The illustration in (24) shows licensing relations in *blieb*, which results in final devoicing as explained below: First of all, let us talk about what the arrows mean in (24). The branching onset x_1 and x_2 and the branching nucleus x_3 and x_4 are in a head-initial constituent government relationship (as discussed in 2.1), and are illustrated by the short left-to-right arrows. The licensing potential comes from the head of the domain x_3 as shown by the long left-to-right arrow. The final empty nucleus parameter is ON for x_6 , therefore, it remains uninterpreted, following the ECP. As a result, the alternating stem-final stop in x_5 has severely depleted the a-licensing potential at its disposal and thus, the a-license is withdrawn from the source L, which is associated with voicing in stops and affricates in her analysis. Brockhaus (1999) uses the element h rather than H to represent friction. In spite of the fact that L is still present in the representation, it is not interpreted because of not having a-license. Consequently, the plosive is phonetically interpreted as voiceless.

Brockhaus' analysis is based on the claim that an onset derives the power to license its segmental material from the immediately following nucleus, which depends on the place of the nucleus within the licensing hierarchy. As mentioned in section 2.1, onsets are licensed by nuclei as they are in pairs all the time. An onset can be followed by a silent nucleus, which means a word final consonant does not

occupy a ‘coda’ as in other frameworks. It should also be noted that parametrically p-licensed domain final empty nuclei do not have the same licensing power that phonetically interpreted nuclei have. In other words, domain final empty nuclei have a weaker licensing power than phonetically interpreted nuclei. The weak licensing power of a domain-final empty nucleus can have a similar effect on its onset to restrictions on word-final ‘coda’ in other frameworks.

Consider another example taken from Brockhaus (1999) to observe alternating stem-final fricatives:

(25) a. [haus] ‘house’

b. [hauzə] ‘houses’

O ₁	N ₁	O ₂	N ₂
	^		
x	x	x	x
h	a	u	
	A		
	h		
	(L)		

O ₁	N ₁	O ₂	N ₂
	^		
x	x	x	x
h	a	u	ə
	A		
	h		
	<u>L</u>		

In (25 a), the element L, which is represented by Brockhaus in parenthesis, is delinked from O₂ because the following nucleus N₂ is a licensed final empty nucleus. Since a final silent nucleus has limited licensing power, L-head cannot be interpreted, which results in voiceless interpretation of the word-final obstruents. Voicing is represented by L-head, therefore, if heads are not licensed by an empty nucleus, it cannot be interpreted. That is why, h or A is not delinked. When there is a suffix [-ə] following the stem, the voiced consonant is manifested as it is in (25 b), where L is licensed to be interpreted. As can be observed in the example above,

voicing alternations in German are not only restricted to stops and affricates; fricatives also go through voicing alternations in the word-final position.

3.2.4.2. Suffix-initial voicing alternations

In a similar analysis, considering the behaviour of nasals and voiced stops, Nasukawa (2000) (also Nasukawa, 1997) analyzes the representation of these consonants by using the element N for both voice and nasality. The reason for choosing N instead of L is that in Japanese, the behavior of nasals plays an important role in the representation of consonants, and thus in the analysis of voicing alternations. Nasukawa also claims that N represents nasals better than L because of its symbolic resemblance. Nasukawa assumes that nasals and voiced stops differ in the headship of N. He represents nasals by using N as an operator, whereas voiced stops are N-headed. N as a head is what the element L is to Brockhaus (1999) in terms of voicing³³. Consider the following Japanese examples taken from Nasukawa (2000):

(26)	kam+te	kande	‘chew+Ger.’
	kam+tara	kandara	‘chew+Subj.’
	şin+te	şinde	‘die+Ger.’
	şin+tara	şindari	‘die+Subj.’

³³ The arguments for the properties of elements were presented in section 2.4. Note that unlike Nasukawa, in this study L-operator will be used to represent nasality in Turkish for the reasons which will be clear in section 3.5.2.

According to Nasukawa, *t* consists of the stop element ʔ, the element A and the noise element h; and *n* consists of ʔ and N-operator. The difference between *d* and *t* depends on the status of N: active and headed in *d*, inactive in *t*. “Active” means that the nucleus is phonetically audible as a result of an interaction with an N element in the preceding position, and “inactive” means that N cannot be heard since there is no N in the preceding position. Therefore, in the Japanese words in (26), Nasukawa claims that activated N in the structure of *d* must be head, which makes it possible for the noise element h to occur as an operator with voicing. Let us illustrate this phonological process:

(27) [ʃinde] ‘die+Ger’³⁴

O ₁	N ₁	O ₂	N ₂	O ₃	N ₃
x	x	x	x	x	x
ʃ	i				e
		R		R	
		ʔ		h	
				ʔ	
		N	→	<u>N</u>	
[ʃ	i	n		d	e]

In the example above, O₂ and O₃ form two adjacent onsets. O₂ must contain a lexically active N, since it triggers post-nasal voicing assimilation. As a result, the output is N in the composition of O₃ to represent voicedness not nasality.

The outcome of the phonological process in Japanese is similar to Turkish suffix-initial voicing alternation. However, in Turkish, all voiced sounds trigger

³⁴ The illustration is adapted to make it easier for the reader.

voiced interpretation of suffix-initial plosives, unlike Japanese where only nasals trigger alternation, as will be discussed in section in 3.3.2.

Nasukawa also assumes N is latently present but inactive in voiceless stops and affricates. An active N in an onset preceding an empty nucleus triggers ACTIVATE N³⁵, which is lexically a functional property of the ultimate head of a given domain at the word level. In simple terms, it means interpretation of N. Consider the following illustration:

(28) [onnagokoro] ‘woman’s heart’

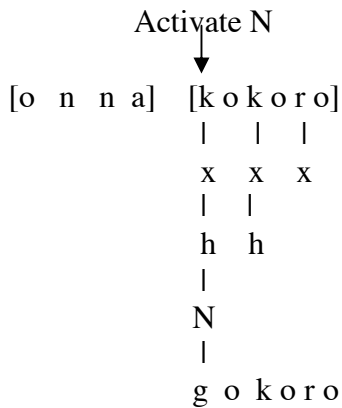

In the example above, N is inactive when the words are not compounded. When a word including nasal consonants, all of which contain N, precedes the word starting with a voiceless stop, “Activate N” allows N to be interpreted.

3.3. Representation of stops and affricates in Turkish

In order to represent stops and affricates using only the 6 elements available in the Revised Theory as mentioned in 2.4, it is a necessity to exploit each element as fully

³⁵ Nasukawa uses the idea of “Activate [α]” in Backley & Takahashi (1998). Activate [α] means “Interpret the melodic element [α].” In Nasukawa’s analysis, [α] is N.

as possible. Elements may represent different properties as a head or as an operator. Sometimes it might be appropriate to have a certain property with an element, while the opposite property does not need to be overtly represented, e.g. voicing contrasts do not need a different element to represent both voice and voicelessness. For instance, the voicelessness of *k* can be represented either as (?.H), (?H), or (?) when L is used to represent voicedness, e.g. [g] would be represented as (L.?) in this case, and voicelessness is not represented. Then, there is the question: does an element represent different properties depending on whether it is a head or an operator? This brings about another question as to which one of the two elements is head, and which one is operator.

It is accepted by many GP researchers that the element ? is used for representing all plosives. Also, the element A is considered to represent coronality, as in the compositions of *t/d*; the element I is used for palatality, as in *ç/c*; and the element U represents labiality, as in *p/b*. The element L can be used in different roles to represent nasality and voicedness, but nasality is usually represented by using the element L as an operator. The element H could be used to represent voicelessness and friction. Unlike nasality, there is no set way of representing friction. In other words, friction can be represented by H-head, H-operator or the lack of ?. It is not certain whether H represents friction as a head or as an operator, or even whether it is represented the same way in all languages. It could be that friction is not represented overtly, but that only plosives are represented by the use of ?, therefore, consonants without ? are assumed to have friction. For example, the representation of *v* could be one of the following assuming that H does not represent voicelessness in either of these roles: (U.H), (U.H) or (U).

There are two questions when various hypotheses are discussed:

- i. Are alternating and non-alternating plosives represented the same way?
- ii. Do voiced plosives become voiceless or voiceless plosives become voiced?

In an attempt to answer these questions, we first need to determine the elements to represent voice and friction.

As can be understood from the discussion of the roles of L and H, there are potentially several different ways voicing contrast could be represented. Firstly, it could be claimed that L-head represents voicedness, while H as a head or an operator represents voicelessness. Secondly, voicedness could be represented by L-head, but voicelessness would not be represented by any element (see section 3.2.4 for Brockhaus's (1999) analysis along the lines of this possibility). In other words, voiceless consonants would not contain an L-head. Thirdly, voicelessness could be represented by H either as head or operator, but instead of using an L-head, voicedness would not be represented by any element, that is, voiced consonants would not contain H in their compositions. Briefly, the options are:

- i. using both L and H,
- ii. using only L,
- iii. using only H.

Let us discuss the problems with the first two alternatives and then explain why the third hypothesis comes out as the best.

In the first hypothesis, it can be problematic to explain stem-final voicing alternations by claiming that two elements are used interchangeably, because such a

proposal would not have any explanatory power. Additionally, claiming two different elements for alternating voiced and voiceless plosives means that they are just represented differently. For non-alternating obstruents, there would be only one form, L or H depending on the word. This would suggest that there is no phonological process taking place to be explained. However, this phenomenon, which is a productive process, will be accounted for in terms of a unifying explanation covering a number of cases. In suffix-initial voicing alternations, the agreement between stem-final vowels and non-nasal sonorants, which do not have L in their compositions and suffix-initial plosives, is not apparent. For example, in *gel-di* ‘come+Past’, the source of L in *d* cannot be *l* since there is no L in its representation.

The second hypothesis is to represent both voicedness with L and voicelessness with H. In Turkish stem-final voicing alternations, voiced fricatives do not exhibit any voicing alternations although according to this hypothesis, they would have L for voicedness in their representations, and they precede final silent nuclei, just like stops and affricates. In Brockhaus (1999), stem-final voicing alternations work well with similar elemental representations and with the same principles, since in German, but not in Turkish, fricatives have voicing alternations just like plosives. In suffix-initial voicing alternations, although vowels and non-nasal sonorants do not have L in their compositions (since they are spontaneously voiced), they can still license the L-head in the suffix-initial position. It is problematic to attribute licensing power to a non-present element. In GP, natural categories are defined by the use of elements not by categories like obstruents or sonorants.

The final hypothesis will be shown to best account for the phonological processes since it is claimed here that it is the one with the most explanatory power. In this proposal, the element H is used as an operator to represent voicelessness. The lack of H means voicedness. The stop element ? is used as a head to play a part in voicing alternations as will be discussed in sections 3.3.1.4 and 3.3.2. Also, the lack of ? represents friction, and L-operator is used to represent nasality.

In (29), representations of voiced plosives are provided with the following examples:

(29) Voiced plosives	a. <u>Stem-final</u>	b. <u>Suffix-initial</u> ³⁶
<i>b</i> (U.?)	<i>turb-u</i> ‘raddish+Acc.’	-
<i>d</i> (A.?)	<i>kurd-u</i> ‘wolf+Acc.’	<i>ev-den</i> ‘house+Abl.’
<i>g</i> (ʔ)	<i>reng-i</i> ‘color+Acc.’	<i>ser-gi</i> ‘exhibition’
<i>c</i> ((A.ʔ)(l)) ³⁷	<i>harc-i</i> ‘tuition+Acc.’	<i>bal-ci</i> ‘honey vendor’

The expressions in (29) do not have H in their composition, which means that they are voiced. The difference between (29 a) and (29 b) in terms of consonant sequences is that in the former, two consonants are in a governing relationship (see section 4.1), and in the latter, the suffix-initial stop has the same voicing property as the stem-final consonant (see section 3.3.2). Now let us consider representations of voiceless plosives with examples in the stem-final and suffix-initial positions:

³⁶ There are no suffixes beginning with *p/b*. The reason for absence of these stops might be a lexical gap, or there might be a historical reason.

³⁷ The representation of *c* involves inner brackets because it has two heads, which will be explained in more detail later in this section.

(30) Voiceless plosives	a. <u>Stem-final</u>	b. <u>Suffix-initial</u>
<i>p</i> (H.U.ʔ)	<i>turp</i> ‘raddish’	-
<i>t</i> (H.A.ʔ)	<i>kurt</i> ‘wolf’	<i>af-tan</i> ‘amnesty+Abl.’
<i>k</i> (H.ʔ)	<i>renk</i> ‘color’	<i>at-ki</i> ‘scarf’
<i>ç</i> ((H.A.ʔ)(I))	<i>harç</i> ‘tuition’	<i>çöp-çü</i> ‘garbage man’

In (30), voicelessness in plosives is represented by H. Representing voicelessness rather than voicedness is preferred because voiceless plosives are generally aspirated in Turkish, and using H in their representation captures this fact. The representation of voicelessness with H rather than by lack of L plays an important role in the analysis of voicing alternations in Turkish.

Denwood (1997 b) represents voicelessness in Khalkha Mongolian by using H as an operator in *t*. The difference between the suggestion here and hers is that she represents *t/d* as A-headed. However, in this account, it is proposed that all the stops have a ʔ-head (see section 3.3.1.4). Also, while in Turkish, the presence of H-operator is claimed for all voiceless stops, in Khalkha Mongolian, *p/b* and *k/g* pairs, unlike *t/d*, are represented without H.

3.3.i. Licensing Constraints in Turkish

In an attempt to determine the elemental composition of Turkish consonants by looking at voicing alternations, we need to discuss licensing constraints. Relationships between elements are generally discussed as Licensing Constraints³⁸ (Charette & Göksel, 1996) in GP as was briefly mentioned in section 2.4. A licensing

³⁸ Unlike OT, constraints in GP cannot be violated or ranked.

constraint must refer to one element at a time. Cooccurrence conditions on elements are defined by specifying head-operator relationships. As a result of the elemental composition of consonants opted for in this study (the elemental representation of plosives is given in (20) and (30) above), the licensing constraints suggested for Turkish consonants are the following:

(31) Licensing Constraints in Turkish

- i. ʔ must be head.
- ii. H, L and U cannot be head.
- iii. A is not a licensor.

The first licensing constraint means that ʔ can only be used as head, while the second states that H, L and U can only be used as operators. The position of ʔ, H, L and U in a phonological expression is therefore claimed to be fixed. As implied in the licensing constraints above, the elements A and I can both be used as head or operator to define different properties of different consonants. However, the difference between A and I is that A is either an operator in an expression, or a head without any operators. ʔ is used in (29) and (30) as a head to define the group of consonants behaving the same way. I is also used as a head in the representation of true palatals above since the licensing constraints do not stipulate any conditions on the nature of I in Turkish. The implications of these licensing constraints will be discussed in the rest of this chapter and in section 5.2. Let us now look at the nature of affricates, in which both ʔ and I are heads in their composition in more detail.

3.3.ii. Affricates

In (29) and (30) above, the affricates c and ζ are represented with two heads as $((A.\underline{?})(\underline{I}))$ and $((H.A.\underline{?})(\underline{I}))$, respectively, since they are true palatals. Denwood (1997: b) assumes that true palatals are universally I-headed. She uses the headedness of I to distinguish true palatals from palatalized consonants in Khalkha Mongolian. While other consonantal phonological expressions can potentially be palatalized, true palatals cannot be palatalized since they already have I-head in their representation, the same element cannot be used twice in the representation of an expression. Representing true palatals with I-head is then the only way to differentiate them from other expressions containing I.

Since Element Theory does not allow more than one head per expression, affricates are considered and represented as complex segments. As represented below, affricates occupy a branching structure, each with its own head.

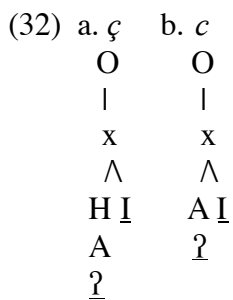

It is important in our analysis to have affricates as ?-headed like stops since they behave exactly like stops in voicing alternations (see sections 3.3.1.4 and 3.3.2 and Chapter 4). They also need to have the element I as a head since they are true palatals and are different from palatalized consonants which are represented with I-operator

(see Chapter 5). Thus, affricates in Turkish are treated as complex segments as represented in (32).

3.3.1. Stem-final voicing alternations

Before we start discussing the voicing alternations in stem-final positions, let us look at some underlying principles and sub-theories used in the formulation of our proposal. In GP, a silent empty nucleus is either parametrically p-licensed in a domain final position, or p-licensed through proper government by the following interpreted nucleus, or p-licensed in an inter-onset governing relationship following the ECP which is formally defined in (16) and repeated below as the Phonological ECP (Kaye, 1995):

(33) A p-licensed nucleus is not phonetically interpreted.

- P-licensing:
- i. Domain-final nuclei are parametrically p-licensed
e.g. English and Turkish ON; Italian and Japanese OFF
 - ii. Properly governed empty nuclei are p-licensed.
 - iii. A nucleus in an onset-onset governing domain is p-licensed.
 - iv. Empty nuclei licensed by ‘Magic’ licensing are p-licensed.

Proper government: α properly governs β if:

- i. α and β are adjacent on the relevant projection,
- ii. α is not itself p-licensed, and
- iii. there is no governing domain separating α from β .

Words like *cam* ‘glass’, which end in a consonant, there is a final silent nucleus, which is parametrically p-licensed in Turkish. In words like *idrak* ‘realization’, in which two consonants are phonetically adjacent, the silent nucleus between *d* and *r* is properly governed by the following phonetically interpreted nucleus³⁹. In word final consonant clusters⁴⁰ like *kart* ‘card’, it is assumed that there is an intervening empty nucleus licensed by inter-onset government.⁴¹ Consider the illustrations of three kinds of p-licensed, i.e. silent, nuclei which are regulated by the principles and parameters of ECP:

<p>(34) a. <i>cam</i> ‘glass’</p> <p>O₁N₁ O₂ N₂</p> <p> </p> <p>[x x x x]</p> <p> </p> <p>c a m</p>	<p>b. <i>kart</i> ‘card’</p> <p>O₁N₁ O₂ N₂O₃ N₃</p> <p> </p> <p>[x x x x x x]</p> <p> </p> <p>k a r t</p> <p> </p> <p>x ← x</p>	<p>c. <i>idrak</i> ‘understanding’</p> <p>x ← x</p> <p> </p> <p>O₁N₁ O₂ N₂O₃ N₃ O₄ N₄</p> <p> </p> <p>[x x x x x x x x]</p> <p> </p> <p>i d r a k</p>
---	---	---

In (34 a), the only empty nucleus is N₂ which is parametrically p-licensed. In (34 b), in addition to the final silent nucleus N₃, N₂ is also silent because it is p-licensed through a governing relationship between O₃ and O₂, and in (34 c), N₂ is silent because it is properly governed by N₃, both of which will be discussed in Chapter 4.

³⁹ As a non-harmonic word, *idrak* is borrowed from Arabic, and its stem is *drk*, so *-rak* is not a suffix.

⁴⁰ The term ‘cluster’ is used in the sense of phonetically adjacent onsets in this thesis.

⁴¹ The reason why inter-onset government is preferred rather than branching rhymes will be discussed in Chapter 4.

In the following sections, four issues will be dealt with. The first discussion is about how stems and suffixes combine morphologically in the framework of GP, which will affect how voicing alternations in Turkish are illustrated. Then, how the licensing power of a final silent nucleus provides an explanation for stem-final voicing alternations will be discussed. After that, previous studies on fortition which explain phenomena other than voicing alternations will be summarized. Finally, fortition is proposed to account for stem-final voicing alternations in Turkish following the representations proposed for plosives in section 3.3 above.

3.3.1.1 Morpho-phonology

As briefly explained in section 2.3, GP recognizes two types of morphology: analytic and non-analytic (Kaye, 1995). Analytic morphology means that when a stem domain forms a new domain with another stem or a suffix, its structure is visible, that is, the new domain is analyzable. However, non-analytic morphology is invisible to phonology. According to Kaye (1995), “irregular morphology is always non-analytic”. Words composed of a stem and a suffix come directly from the lexicon if they are considered to be non-analytic. It is desirable that a phonological theory should be able to explain as many phenomena as possible by using phonological processes and principles, instead of accepting them as “non-analyzable” directly coming from the lexicon. Besides, stem-final and suffix-initial voicing alternations take place following phonological processes.

In this section, it will be discussed whether or not Turkish suffixes triggering or undergoing voicing alternation combine analytically with a stem, and how this can be determined. In order to do that, this section is divided into three sub-sections. First

of all, a case of Polish morpho-phonology will be described in order to draw a parallel to Turkish. Then, certain types of Turkish suffixes will be discussed to account for voicing alternations. Finally, parsing cues in Turkish will be discussed.

3.3.1.1.i. Polish

In order to figure out what type of morphology, voicing alternations exhibit in Turkish, let us look at how changes in Polish phonology as a result of suffixation are analyzed. In the literature, there are examples of an analytic morphology account of suffixes causing alternation in the stem. In Gussmann & Kaye (1993), Polish suffixation is considered to be an example of analytic morphology. The interpretation of empty nuclei is called “yer”, and it is phonetically realized as [e] or [ie]. Both in [pies] ‘dog’, and the diminutive suffix [-ek], there are empty nuclei which are phonetically realized. When suffixation takes place, there is no proper government. Gussmann & Kaye (1993) discussed that the word [[[piés]ek]ek] ‘dog+Dim+Dim.’ is analytic although there is an alternation in the onset of the first suffix as in [piesétʃek]. Consider the following illustrations provided below to make the explanations clearer:

(35)a.[pies]‘dog’ b.[piések]‘dog+Dim’ c.[piesét]jek] ‘dog+Dim+Dim.’

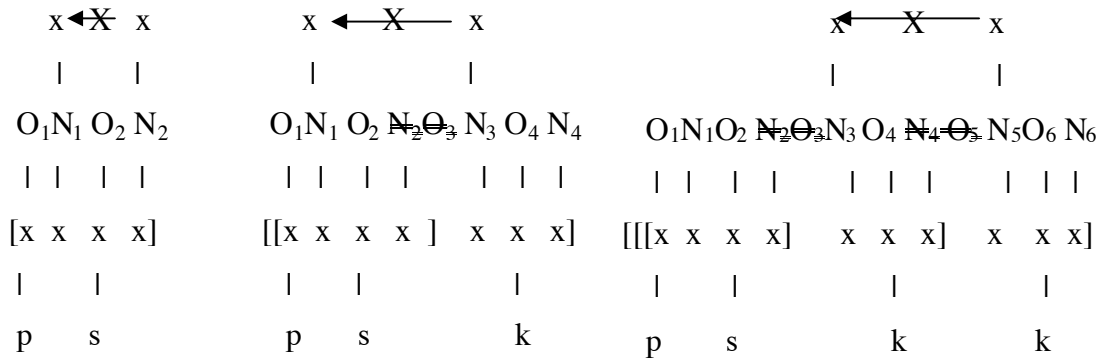

In (35 a), the empty nucleus in N₁ is interpreted since N₂ is parametrically p-licensed and cannot properly govern N₁. Denwood’s (1997 b) interpretation of these illustrations is the following: In (35 c), since N₃ is stressed, it cannot be properly governed by the following phonetically expressed nucleus. The reason why N₁ is not properly governed by stressed N₂ is that previously established relationship between N₁ and N₃, as can be seen in (35 b), cannot be altered even if there is a new relationship between N₃ and N₅. The change in the consonant of the first suffix as a result of the second suffixation is not considered as a sign of non-analytic morphology because the onset gets a new licenser in the interpreted following nucleus after the domain-final one is reduced from the structure. The Polish case is relevant to Turkish morpho-phonology since voicing alternations are triggered by suffixation like Polish, and there is a voicing change in domains, which could imply the type of morphology in Turkish.

3.3.1.1.ii. Turkish suffixes

Turkish is an agglutinative language, where stems combine with suffixes with different results. Stem-final voicing alternations also involve suffixation. In this study, following much work done earlier, four types of suffixes are proposed in Turkish with respect to the nature of consonants and vowels involved⁴². The difference of the categories suggested here is apparent in (36 ii) and (36 iii) where the categories are determined by voicing alternations.

(36) Types of Turkish suffixes

- i. Suffixes *-ken* ‘while’, *-ki* ‘Poss.’, which undergo neither vowel harmony nor voicing alternation
- ii. Suffixes like *-lar* ‘Pl.’, *-siz* ‘without’, in which suffix-initial consonants do not undergo voicing alternation, but vowel harmony is still at work⁴³
- iii. Suffixes like *-DA* ‘Loc.’, *-CI* ‘Ag.’ in which the suffix-initial stop undergoes voicing alternations, and vowels follow vowel harmony
- iv. Vowel-initial suffixes like *-(y)I* ‘Acc.’, *-(y)A* ‘Dat.’ which undergo vowel harmony and cause voicing alternation in the alternating stem-final stop⁴⁴

⁴² Stressable and unstressable suffixes are not in different categories since stress is not relevant to the purposes of this study. Also, no distinction has been drawn between verbal and nominal suffixes in this list.

⁴³ In suffixes, vowels undergoing vowel harmony and consonants undergoing alternation are shown by italicized capital letters. *I* and *A* are used for vowels, and *D*, *G* and *C* are used for the relevant consonants.

⁴⁴ There is a difference between the fourth type (e.g. the accusative suffix *-(y)I*) in and the present continuous suffix *-Iyor* in that the former is used with *y* after stems ending in a vowel (e.g. *dere-yi* ‘stream+Acc.’) and the latter loses its vowel after stems ending in a vowel as in *gülmü-yor* ‘laugh+Cont.’ However, they both trigger stem final voicing alternations as in *kab-ı* ‘container+Acc.’ and *gid-iyor* ‘go+Cont.’. *A* in the composition of a word-final nucleus is not interpreted when *-Iyor* follows as in the example *arı-yor* ‘search+Pres.’ (see section 6.2).

Consonant-initial suffixes in the first three types above do not trigger any changes in the stem. In other words, even though stems end in alternating plosives, the existence of these suffixes does not cause any alternation. For instance, *kitap* ‘book’ which ends in an alternating stop remains voiceless as in *kitap-ken* ‘book+while’, *kitap+lar* ‘book+Pl.’ and *kitap-ta* ‘book+Loc.’.

Unlike the first type, the suffix-initial plosives in the third type undergo voicing alternations as in *ev-den* ‘home+Abl.’ and *raf-tan* ‘shelf+Abl.’ (see section 3.3.2). All vowel-initial suffixes in the fourth type cause alternating stem-final plosives to be interpreted as voiced. For example, in *kap – kab-ı* ‘container+Acc.’ and *renk – reng-e* ‘color+Dat.’ Not only vowel harmony is at work, but also suffix-initial vowels trigger voicing alternations in stem-final plosives.

The important question is whether these alternations are evidence of analytic or non-analytic morphology. There are three potential possibilities: i. All suffixes triggering or undergoing alternation combine with the stems either analytically, ii. or non-analytically, or iii. all consonant-initial suffixes could be analyzed analytically, and all suffix-initial suffixes could be analyzed non-analytically. The last possibility would result in a division of suffixation based only on the shape of suffixes. However, some suffixes, which have the same shape, have different properties such as attracting stress to the preceding nucleus, as in negative suffix *–ma*, but not the nominalizing suffix *–ma*.

3.3.1.1.iii. Parsing cues

Parsing cues are the signs that show us where words start and end, and what their morphological structure is like. They can take many different forms, like

suprasegmental phenomena such as vowel harmony and stress, phonotactic constraints on segments.

Parsing cues are first mentioned in Kaye (1989). In Kaye (1995), regular morphology is considered as analytic morphology, and analytic morphology has an interesting property in terms of empty nuclei. Empty nuclei are found frequently at the ends of domains, so finding empty nuclei is a reliable parsing cue in English. An example like *dreams* shows that the [mz] sequence is separated by an empty nucleus because the vowel length is maintained, and these two consonants are not homorganic, which is impossible for true clusters.

Turkish has one of the ‘classic’ parsing devices, vowel harmony, which show the larger word-domain. One of the parsing cues in Turkish is that the only way that three consonants can be phonetically adjacent is by adding a consonant initial suffix to a word-final consonant cluster. For example in *kurtlar* ‘wolves’, the end of the stem can easily be pinpointed by considering the number and the nature of consonants. That is, *kurt* ‘wolf’ is a stem, and *-lar* ‘Pl.’ is a suffix, firstly because of the fact that there cannot be three consonants in stem-medial position, secondly because of the fact that the suffix cannot start with *tl*, or no word begins or ends in *tl*. Both voicing alternations and the constraint on the number of phonetically adjacent consonants tell us where the stem ends and where the suffix starts, which means they are good parsing cues, and thus examples of analytic morphology.⁴⁵

It is claimed in this study that voicing alternations could also be considered a parsing device. In Turkish, there are words like *abla* ‘older sister’, and such words are assumed to come directly from the lexicon (not formed through productive suffixation), and thus their structure is not visible to phonology. *l* can follow any

⁴⁵ There are few exceptions to the point made here like *böğürtlen* ‘blackberry’, which might be the combination of a historical stem and a suffix.

consonant. Also, when *l* in the plural suffix *-lar* follows a stem, the final plosive is always voiceless, but this has nothing to do with *l*. If *l* had properties to make voiced plosives voiceless, we would predict **apla*. Since we get *abla* ‘older sister’, *abla* is not complex like *kitap-lar* ‘book+Pl.’.

The existence of examples in (37) below indirectly supports our claim that suffixes undergoing or triggering voicing alternations combine with the stems analytically. Let us consider plosives in word-medial adjacent consonants whose voicing is not predictable by looking at the following or preceding expressions.

- | | | | | | |
|------|----|---------------|--------------|--------------|---------------|
| (37) | a. | <i>ecdat</i> | ‘ancestors’ | <i>Abdi</i> | ‘proper name’ |
| | b. | <i>meclis</i> | ‘parliament’ | <i>kablo</i> | ‘cable’ |
| | c. | <i>icmal</i> | ‘abstract’ | <i>idman</i> | ‘training’ |
| | d. | <i>kibrit</i> | ‘matches’ | <i>İdris</i> | ‘proper name’ |
| | e. | <i>şiddet</i> | ‘violence’ | <i>Abbas</i> | ‘proper name’ |

In (37), we observe that voiced plosives *b*, *d*, *c* are used before an empty nucleus, and we do not find any restrictions as we would expect in stem-final positions. In (37 a), voiced plosives are followed by voiced plosives in the word-medial position. Although voicing of the second plosive seems to be similar to suffix-initial voicing alternations, the difference is that in suffix-initial voicing alternations, it is not possible to find voiced plosives in the stem-final positions.

(37 b and c) are parallel to the cases of stem-final voicing alternations before suffixes like *-lar* ‘Pl.’ or *-mA* ‘Ger.’, where we find voiceless plosives in the stem-final positions. However, in these examples, there are voiced consonants before *l* and *m*. For example, if (37 c) were stem+suffix, we would predict **içmal*. The consonant

sequences in (37 d) are not similar to typical cases of stem+suffix sequences since there is no suffix starting with *r* in Turkish, but we would expect voiceless plosives before an empty nucleus in stem-final positions anyway. (37 e) includes examples with two identical consonants. If the sequences in (37 a and e) were stem+suffix sequences, we would first expect a voiceless stem-final plosive, and then a voiceless suffix-initial plosive. In other words, there is no morpho-phonology in (37) since plosives in word-medial positions do not undergo any phonological processes we observe in stem-final positions.

To sum up, it is claimed here that voicedness of phonetically adjacent consonants in word-medial positions differs from suffix-initial and stem-final voicing alternations. In the light of the previous discussions, it is possible to claim that voicing changes in stem-final or suffix-initial plosives in Turkish are evidence for dependent analytic morphology.⁴⁶

3.3.1.2 Licensing power of the final silent nucleus

One of the main proposals of this study is that stem-final voicing alternations are caused by the weak status of the final silent nucleus in Turkish. In other words, final silent nuclei cause constraints on the onsets preceding them because they have weaker licensing power than a phonetically interpreted nucleus. When the limited licensing capacity of a silent nucleus is taken into consideration, many phonologists claim that there is “lenition” in the preceding onset, whereas, here “fortition” of the preceding onset is considered to be responsible for stem-final voicing alternations. In

⁴⁶ It is proposed here that suffixes starting with non-alternating stops in the first type above are examples of independent analytic morphology. For example, in the word *uyur-ken* ‘sleep+while’, there is neither vowel harmony nor suffix-initial voicing alternation. This is similar to compounds like *deniz+altı* ‘submarine’, which are also examples of independent analytic morphology.

this study, a fortition analysis of stem-final voicing alternations follows from the use of certain properties of certain elements in the representations of plosives.

It needs to be clarified now how the weaker licensing power of a final silent nucleus is interpreted in this study, which differs from its use elsewhere as in Brockhaus (1999). Brockhaus, as discussed in 3.2.4.1, claims that the element L, which represents voice, is delinked from the stem-final obstruent since the final silent nucleus has weaker a-licensing power for its onset. In [bli:p] ‘stayed’, L is delinked from the composition of *p* since it precedes a final silent nucleus. Delinking of L analysis would not work in Turkish since such an analysis would result in devoicing of stem final voiceless plosives. In Turkish, the weaker status of a final silent nucleus causes the stem-final onset to gain an element, which will be discussed in section 3.3.1.4 below.

Final silent nuclei are different from word-medial and word-initial empty nuclei. As pointed out above, domain-final empty nuclei are parametrically p-licensed in Turkish to remain silent. When they are silent, they are considered to be weak in this study. On the other hand, word-medial silent nuclei are not weak, and they only remain silent when they are properly governed or when they are between two consonants which are in relationship. In Dialect A, as will be discussed in section 5.4, N_1 in borrowed words is inaccessible for proper government, thus it needs to be phonetically interpreted.

At this point, let us discuss two analyses by Rhee (1996) and Kim (1996) concerning “word-final neutralization” in Korean, which could be analyzed as a parallel phenomenon to stem-final voicing alternations in German and Turkish. In Korean, only neutral⁴⁷ consonants can appear in a word-final position. Rhee (1996)

⁴⁷ Neutral consonants are unaspirated.

suggests that because of the weak licensing power of final silent nuclei, onsets preceding them lose an element. In his study, H represents aspiration. He proposes the delinking of H from the onset containing headed consonants before final silent nuclei because a domain final empty nucleus does not license H. He represents all the consonants which appear word-finally as ? -headed. For example, $[\text{kap}^{\text{h}}\text{a}]$ ‘repay+because’ is interpreted as $[\text{kap}]$ ‘repay’ before a final silent nucleus as a result of the delinking of H.

Kim (1996) claims that an H-headed expression is not licensed by the final silent nucleus because the domain-final empty nucleus is too weak to license a strong onset, which is H-headed in this case. H also represents aspiration in Kim’s study. She has two constraints on onsets preceding the final silent nucleus, which are;

- (38)
- i. H-head is suppressed in stops and fricatives, and
 - ii. The element ? is added in fricatives and affricates.

While the former constraint is similar to Rhee’s account, the latter is an additional tool that Kim suggests to account for stem-final fricative-stop alternations in Korean. For example, $[\text{s}]$ in $[\text{os-e}]$ ‘clothes+Loc.’ is interpreted as $[\text{t}]$ in the word-final position as in $[\text{ot}]$ ‘clothes’. She represents $[\text{s}]$ as (A.H) and $[\text{t}]$ as (A. ?), which means that first H is suppressed, and then ? is added into the composition.

The difference between these three analyses and the one adopted here is that while they mainly claim that weak licensing power of an empty position leads to non-interpretation of an element, it is claimed here that weak status of an empty position calls for strengthening of the final consonant in Turkish by gaining the H element. In other words, in German, the L element is not interpreted when the

domain-final empty nucleus is p-licensed; likewise, in Korean H-head is delinked or suppressed preceding a final empty nucleus.

Since fortition will be discussed for Turkish stem-final voicing alternations in section 3.3.1.4 for the first time in GP in the available literature, let us discuss languages in which fortition is proposed to account for phonological processes.

3.3.1.3 Fortition in other languages

Although fortition is implied for Korean word-final neutralization by Kim (1996), she does not specifically account for the phonological process responsible for it. It should be emphasized that fortition has not been proposed to account for stem-final voicing alternations in the available literature before. Brockhaus (1999), like many other researchers, argued for lenition to explain German stem-final devoicing. However, fortition has been claimed for other phenomena in a number of languages, e.g. the addition of ʔ into the composition of Korean stem-final fricatives as discussed above.

First of all, Harris (1996) analyzes Greek Cypriot and claims fortition of the sonorant [j] in a certain context. [j] is realized as [k] after [r], and it is interpreted as [dʒ] after obstruents. For example, /terjoza/ becomes [terkoza] ‘I match’; /kapjos/ becomes [kafdʒo]⁴⁸ ‘someone/something’. Harris (1996) claims that in Cypriot Greek, fortition is done by the addition of ʔ, and takes place when “the Complexity Condition prohibits a coda position from sponsoring a representationally more complex segment than the segment occupying the following onset”. This means that an onset following a branching rhyme needs to be fortified if it is less complex than

⁴⁸ There is also stem-final lenition in this example.

the branch of a rhyme. As discussed in the first chapter, inter-constituent government is universally head-final.

Kula (2002) analyzes Bemba and proposes fortition of [β] to [b] when preceded by the nasal prefix *m-*, and [l] to [d] after *n-*. For example, [βila] ‘sew’ becomes [mbila] ‘I sew’, whereas, [leka] ‘stop’ becomes [ndeka] ‘I stop’. She also claims the Complexity Condition to be responsible for strengthening of a second consonant of two consonants to be equally or more complex than the first of two consonants. In both studies, fortition takes place when two consonants are in a relationship.

Kaisse (1992), analyzing the same examples of Harris (1996), claims fortition of [j] to [k] in Greek Cypriot in the feature-based framework of Generative Phonology. The phonological process is spreading of [+consonantal] from a consonant onto a glide, which is similar to adding the ʔ element to strengthen an onset in GP.

3.3.1.4 Fortition in Turkish

In this study, one of the main claims is that the element H needs to be added to fortify stem-final plosives followed by final silent nuclei, which are weak. Namely, when a word ends in a silent nucleus, stem-final plosives preceding the final empty nucleus are fortified by H. It is claimed here that onsets containing ʔ-head are weak unless they have H. Although this might be surprising, there is something special about ʔ-head in Turkish. The reason why only plosives are fortified is that sonorants or voiced fricatives do not have ʔ in their composition.

Goh (1997) proposes the Beijing Mandarin p-licensing constraint, such that if O₂ is p-licensed, then N₂ is not, and if N₂ is p-licensed O₂ is not. That is, only one of the two components can be interpreted, while the other must be silent. Note that in

Chinese, words consist of only two pairs of ON. He attributes the weakness of the second ON pair to Licensing Inheritance (Harris, 1992; 1997): the final onset-nucleus pair has limited licensing potential. That is to say, the licensing power is handed down from the head of the domain N_1 to O_1 and to N_2 and from N_2 to O_2 .

The proposal for Chinese (Goh, 1997) can be adapted to account for stem-final voicing alternations in Turkish, thus, if N_2 is strong, O_2 should be weak; if N_2 is weak, O_2 should be strong. If N_2 is empty, it does not have enough licensing potential to license the content of the stem-final onset. The more licensing potential domain-final nucleus has to use for licensing the content of its onset, the less it has for itself, and the less licensing potential domain final empty nucleus uses to license the content of its onset, the more it has for itself.

Brockhaus (1999) uses the weak licensing potential of the domain-final empty nucleus to explain restrictions on its onset. The restrictions on the stem-final onset show that the domain-final empty nucleus is weak.

In Turkish it is claimed that when a stem-final onset containing ? is followed by a phonetically expressed nucleus as a result of suffixation, then it does not have to be fortified since the phonetically expressed nucleus is strong, which means that the onset can be weak. In other words, a weak nucleus (parametrically p-licensed domain final empty nucleus) needs a strong onset (? -head with H operator). In this phonological process, voiced plosives represented with the absence of H are realized as voiceless by the fortition of H. Fortition by H can be informally called word-final devoicing.

In order to observe the fortition process more closely, let us consider the following examples in Turkish:

(39) a. *kanat* ‘wing’

O ₁ N ₁	O ₂	N ₂ O ₃	N ₃	
[x	x	x	x	x]
k	a	n	a	l
			A	
			H	
			<u>ʔ</u>	

b. *kanad-ɪ* ‘Acc.’

O ₁ N ₁	O ₂	N ₂ O ₃	N₃	O₄	N ₄
[[x	x	x	x	x]	x]
k	a	n	a	l	ɪ
				A	
				<u>ʔ</u>	

In (39 a), we have a word ending in a stem-final stop which has to be fortified with the element H. Since N₃ is weak as a final silent nucleus, O₃ must be strong. That is, for O₃ to be strong, ʔ-head requires H-operator. In (39 b), the existence of interpreted nucleus vowel allows O₃ to remain weak, i.e. O₃ does not need fortifying, since N₄ is now the licenser for O₃. Reduction as claimed by Gussmann & Kaye (1993) means that an empty nucleus followed by an empty onset without a skeletal point is removed from any phonological representation. Following this principle, N₃ and O₄ are reduced from the structure allowing N₄ to be immediately adjacent to O₃.

Although (40 a) resembles the illustration in (39 a), (40 b) is different from (39 b) in terms of the composition of *t* before a vowel-initial suffix:

(40) a. *at* ‘horse’

O ₁ N ₁	O ₂	N ₂	
[x	x	x	x]
a	l		
	A		
	H		
	<u>ʔ</u>		

b. *at-ɪ* ‘Acc.’

O ₁ N ₁	O ₂	N₂	O₃	N ₃
[[x	x	x	x]	x]
a	l			ɪ
			A	
			H	
			<u>ʔ</u>	

In (40 a), there is a word ending in a non-alternating voiceless stem-final stop. However, the reason why it has the element H is not because it has been fortified, it

is because it already has H in its composition. As can be seen in (40 b), when *t* is followed by a suffix starting with a vowel, there is no change in the composition, showing that the stem-final stop is already voiceless. Non-alternating examples like the one in (40) do not weaken our fortition argument in that the final silent nucleus in (40 a) is still weak, but H in the composition O_2 is not a result of fortition, it is lexically there. In (40 b), as a result of reduction, O_2 is adjacent to N_3 , a phonetically interpreted nucleus and thus strong, but O_2 already has the H element. It seems that “If O is strong, N must be weak” does not logically follow from the claim that “If N is weak, O must be strong.”

By looking at the set of elements selected to represent plosives, lenition of H could also be claimed before vowel-initial suffixes. However, this would not help differentiate alternating and non-alternating plosives because they all have H in their composition. The superiority of H-fortition argument over H-lenition can be seen in (40 b). In a lenition analysis, it would have to be explained why sometimes H delinks, as L did in the German analysis, and sometimes not. However, in our analysis, the H element is added to the composition of all stem-final plosives licensed by a parametrically p-licensed domain final empty nucleus. This being said, it might be claimed, on the other hand, that this is not true for all plosives. Let us consider the cases which might be considered as counter-examples to the proposal made in this study.

In Turkish, there are some words which are generally assumed to end in voiced plosives like *ad* ‘name’, *lig* ‘league’, *hac* ‘pilgrimage’, *rab* ‘Lord’ and *etüd* ‘study’ (Inkelas, 1995; Kallestinova, 2004; Orgun, 2004). The monosyllabic words are generally used with a suffix starting with a vowel as in *ad-ı* ‘name+Acc.’, *lig-i* ‘league+Poss.’, *rabb-e* ‘Lord+DAT.’. It is claimed here that these words are also

fortified in spoken Turkish word-finally, and when followed by a consonant-initial suffix. 40 Turkish native speakers⁴⁹ were asked to pronounce these words with and without suffixes starting with suffix-initial consonants. 35 of them devoiced the stem final consonant of these “exceptional” words. To exemplify, the pronunciation of these words with the locative suffix *-DA* have the following results in spoken Turkish: [atta] ‘name+Loc.’, [likte] ‘league+Loc.’, and [hatʃta] ‘pilgrimage+Loc.’. Let us consider the illustration of a word which has been claimed to end in a voiced consonant:

(41) a. *ad* [at] ‘name’

O ₁	N ₁	O ₂	N ₂
[x	x	x	x]
a			
	A		
	H		
	<u>ʔ</u>		

b. *ad-ı* ‘Acc.’

O ₁	N ₁	O ₂	N₂	O₃	N ₃
[[x	x	x	x]		x]
a					ı
	A				
	<u>ʔ</u>				

In the example above, O₂ in (41 a) is fortified since it precedes a final silent nucleus. It is claimed here that such words are fortified like all other words ending in voiced plosives. In (41 b), when the vowel-initial suffix is added to the structure, we observe reduction, and thus the structurally adjacent filled nucleus is strong and allows O₂ to remain weak.

⁴⁹ The subjects are university students with pre-intermediate level of English. The data was collected from the subjects by giving them a context to use these words in a conversation. The study was an impressionistic one, in which these words are explained, and they were asked to use them in a sentence without suffixes and with case markers. For example, subjects uttered sentences like *Hac ne demek?* ‘What does pilgrimage mean?’ and *Hacda kaç kişi öldü?* ‘How many people died during the pilgrimage?’ The data was noted simultaneously and discussed with the subjects afterwards comparing how they thought they pronounced the words in question and how they actually pronounced them.

The reason why these words are generally assumed to end in voiced plosives might stem from the spelling of these words, and “careful” speech conventions, some speakers may try to pronounce the voiced consonants in order to differentiate *ad* ‘name’ and *hac* ‘pilgrimage’ from words like *at* ‘horse’ or *haç* ‘cross’. There is a widespread misconception among many native speakers of Turkish, that Turkish is a language which is pronounced exactly as it is spelled in written texts. As a result, studies done based on reading a written text might give different results from the data used here. It should also be noted that when speakers are directly asked how they would pronounce these words, they might give the “standard” careful speech form, which contradicts the form they use in their normal speech.

Note also that words like *hacc-i* ‘pilgrimage+Acc.’⁵⁰ and *rabb-i* ‘Lord+Acc.’ have two identical consonants when followed by a vowel-initial suffix. It is claimed here that those words have a consonant attached to two onset positions. However, unlike the origin language Arabic, Turkish cannot have word-final geminates. Consider the following examples where true geminates are pronounced only when the empty position is properly governed by the nucleus in the suffix.

(42) a. [hatʃ] ‘pilgrimage’ b. *hacc-i* ‘pilgrimage+Acc.’

O ₁ N ₁ O ₂ N ₂ O ₃ N ₃	O ₁ N ₁ O ₂ N ₂ O ₃ N ₃
[x x x x x x]	[x x x x x x]
\ /	\ /
h a c	h a c ɪ

⁵⁰ Aksan et. al. (1978) and Demircan (1979) observe that affricates go through a process before *t* and *d* in spoken Turkish as in *geç-tim* [geʃtim] ‘pass+Past.1stP.’ and *ecdad* [eʒdat] ‘ancestors’. This is a phonetic process and is not in the domain of this study. The elemental composition suggested in this present study could, however, account for the reason why the stop element ʃ is not interpreted in this context.

In (42 a), N_2 is not p-licensed because there cannot be inter-onset government between two onsets sharing one consonant, N_3 , as a final silent nucleus, cannot properly govern N_2 . Thus, geminates are not audible word-finally. The word-final consonant c is fortified with H since N_3 is empty. On the other hand, in (42 b), there is a suffix starting with a vowel which can properly govern N_2 , thus allowing the geminate to be audible. Since this phenomenon is not directly related to the elemental composition of consonants, this has been left out from the illustration above since these words are unusual and can be considered as exceptions.

Another set of examples which need to be discussed separately are the words ending in k/g . In the examples above, stem-final voicing alternations are exemplified with p/b , t/d and $ç/c$. There is also k/g voicing alternation which is different from other plosives in stem-final voicing alternations. Unless k is in a cluster, it alternates with \emptyset when followed by a suffix starting with a vowel in most cases.

As can be seen in (43) below, k alternates with g only in a stem-final cluster is after $-en-$. In other words, there is no alternation like $çok - *çog-u$ ‘many+Acc.’ or $bebek - *bebeg-i$ ‘baby+Acc’. When k is not preceded by $-en-$, it alternates with \emptyset when followed by a suffix starting with a vowel.

(43) a. <i>renk</i> ‘color’	b. <i>reng-i</i> ‘Acc.’
$O_1 N_1 O_2 N_2 O_3 N_3$	$O_1 N_1 O_2 N_2 O_3 N_3 O_4 N_4$
[x x x x x x]	[[x x x x x x] x]
r e	r e
L H	L ?
?	

In (43 a), N_2 is licensed by a relationship between O_2 and O_3 (see Chapter 4). N_3 is parametrically p-licensed, and O_3 is fortified by H. In (43 b), we observe that the

stem-final stop is manifested as voiced since N_4 is interpreted. It can be claimed that when a phonetically interpreted nucleus follows k , it has only the stop element $?$, which cannot be interpreted unless it is phonetically adjacent to onset containing specifically L in a governing relation. When the domain final nucleus is silent, the onset occupied by $?$ -head is fortified with H and realized as k . Note that this is true only for stem-final onsets, which are conditioned according to the status of the final empty nucleus. In other words, the word-initial and word-medial g can stay on its own without the support of a preceding onset.

Although $k\emptyset$ is not a voicing alternation per se, it is claimed here that it is related to voicing alternations, and can be accounted for by fortition⁵¹. Let us look at the illustrations below:

(44) a. *çok* ‘many’ b. *çoğu* ‘many+Acc.’

O_1N_1	O_2	N_2	O_1N_1	O_2	$N_2\emptyset_3$	N_3		
[x	x	x	x]	[[x	x	x	x]	x]
ç	o	l	ç	o		u		
	H			<u>?</u>				
	<u>?</u>							

In (44 a), O_2 is not interpreted because the stop element is not attached to the skeletal point, which is the difference between g and \emptyset . In (44 b), since N_2 is weak, O_2 has to be strong, and thus it is fortified. When fortition takes place, $?$ -head can be interpreted with the addition of H.⁵² In *reng-i* ‘color+Acc.’ it is claimed here that the empty onset with a skeletal point, which is not in a governing relationship with the

⁵¹ There are examples like *çok-uz* ‘many+1stPer.PL.’, in which k shows no alternation with \emptyset . Such cases can be analyzed as cases of non-analytic morphology. That is to say, there is no reduction as observed in (44 a), and the internal structure of the domain is not visible to phonology.

previous onset, has an uninterpreted ʔ element, and it is now subject to the ECP. When this “empty onset” is followed by a silent final nucleus, it is fortified with H and phonetically realized as [k] word-finally.

The last set of data which might be considered counter-examples to the analysis in this study is *dialog* ‘dialogue’ and *psikolog* ‘psychologist’. These words seem to end in a voiced stop and alternate with \emptyset , especially in the dialect of educated speakers. However, as claimed for the other words ending in “voiced” consonants, these words end in [k] when pronounced⁵³. As explained in (44), fortition is at work in these words with the difference that ʔ -head is not attached to the skeletal point unless it is fortified with H. Since the claim in this study is not the delinking or suppression of H, the question why *k* alternates with zero or *g* is not a relevant theoretical issue to our study.

After having discussed stem-final voicing alternations in some length, it is time to consider suffix-initial voicing alternations which is a completely different phonological process than stem-final voicing alternations.

3.3.2. Suffix-initial voicing alternations

In order to account for suffix-initial voicing alternations in Turkish, we claim that suffix-initial plosives are voiced like stem-final alternating consonants. This means that they do not have the H element in their representations. In other words, when there is a vowel or a voiced consonant in the stem-final position, we only observe the

⁵² Note that ʔ represents *g*, but since it is not attached to a skeletal point no phonetic interpretation is audible.

⁵³ For some speakers, although they are pronounced voiceless, they can be unaspirated. These data need to be tested in phonetics laboratory in order to determine their exact nature.

voiced counterparts of suffix-initial consonants, that is, there is no change from voiced to voiceless. It is claimed here that the element H, which represents voicelessness in this study, spreads to the suffix-initial plosive from the stem-final consonant when it is present, it results in a voiceless plosive.

Consider the following examples illustrating the contexts where suffix-initial consonants have voiced and voiceless counterparts:

(45) a. *kanat-ta* ‘wing+Loc.’ b. *hava-da* ‘air+Loc.’ c. *sen-de* ‘you+Loc.’

$O_1N_1 \ O_2 \ N_2O_3 \ N_3 \ O_4 \ N_4$ [[x x x x x x] x x] k a n a l l a A A H→ ? ?	$O_1N_1 \ O_2 \ N_2O_3 \ N_3$ [[x x x x] x x] h a v a l a A ?	$O_1N_1 \ O_2 \ N_2O_3 \ N_3$ [[x x x x] x x] s e l l e A A L ?
--	---	---

As can be seen in (45 a), the H element in the stem-final position spreads to the suffix-initial onset, which results in voiceless interpretation of the suffix-initial stop O_4 . N_3 is parametrically p-licensed since it is domain final, and does not block the spreading of the H element. Note that O_3 and O_4 are adjacent at the segmental level not the skeletal tier. However, in (45 b), where the stem ends in a vowel, and in (45 c), where the stem-final consonant is a sonorant, there is no H in the composition of the stem-final expressions to spread. As a result, suffix-initial plosives are voiced in (45 b and c). Consider the following examples where we do not observe H-spreading although stem-final onsets have the H element in their composition:

(46) a. <i>kanat-lar</i> ‘wing+Pl.’	b. <i>git-me</i> ‘go+Ger.’	c. <i>ses-li</i> ‘voiced’
O ₁ N ₁ O ₂ N ₂ O ₃ N ₃ O ₄ N ₄ O ₅ N ₅	O ₁ N ₁ O ₂ N ₂ O ₃ N ₃	O ₁ N ₁ O ₂ N ₂ O ₃ N ₃
[[x x x x x x] x x x x]	[[x x x x] x x]	[[x x x x] x x]
k a n a l l a r	g i l l e	s e l l i
	A U	A A
	H X → U	H X → U
	?	?

In (46), despite the presence of the H element in the stem-final consonant, there is no spreading since it is claimed here that the suffix-initial consonants *l* and *m* do not have the stop element ? in their compositions.

H apparently does not spread to sonorants, which do not have voiceless counterparts in Turkish. Spreading cannot be tested with fricatives since there are no suffix-initial voiced fricatives in Turkish. However, H in the composition of a fricative can spread to a suffix-initial stop as in *kuş-tan* ‘bird+Abl.’. In Turkish, fricatives do not normally have voicing alternation except for the cases resulted from assimilation *yazsa* [yassa] ‘write+Des.’, *kazsa* [kassa] ‘dig+Des.’ etc. Demircan (1979, 1996), Aksan et.al. (1978) and Ergenç (1995) claim that fricatives go through “partial assimilation”. However, such a process is restricted to suffixes starting with *s*, and it does not take place in word final positions. Additionally, such alternations take place in spoken language and in the domain of phonetics rather than phonology. Therefore, according to the hypothesis here, spreading of H is only possible when the suffix-initial onset contains ?-head in its composition.⁵⁴

In addition to the previous discussions, Brockhaus (1999) notes that the elements most notably deprived of their a-licenses, are H and ? i.e. when there is no a-license,

⁵⁴ It could be proposed that when the suffix-initial onset has U, H cannot spread. This constraint would account for the reason why H does not spread to *m* and *l*. However, such a constraint should be the result of licensing constraints, which is possible.

there is no interpretation. Although L is delinked in her study, she recognizes the status of elements H and ? in terms of being deprived of their a-license. Kim (1996) also has restrictions on the element H in similar contexts in Korean. She assumes that H is present in the lexical representation of neutral plosives, but that it is not interpreted before a final silent nucleus. These two accounts are similar to voicing phenomena in Turkish, which seem to be related to the interaction between H and ?.

It is claimed here that in Turkish, H in the composition of stem-final consonant spreads to consonant-initial suffixes containing ?-head, which can be considered as a short distance consonant harmony. Considering the licensing constraints suggested here for Turkish, ? must be head and H cannot be head, H spreads as an operator to the suffix initial onset position containing ?-head. The direction of H-spreading is left-to-right in Turkish. This process is similar to vowel harmony, which will be explained briefly in section 5.2, in that the elements I and U also spread from left to right (Charette & Göksel, 1996, 1998). This process also resembles the licensing of I in the suffix by the I element in an onset, which will be discussed in section 5.4.1.

After all these observations and discussions where H-spreading is possible, it is necessary to talk more about why the element H does not spread to sonorants.⁵⁵ GP⁵⁶ does not appear to offer a way to distinguish sonorants from obstruents in terms of voiced/voiceless distinction. The difference between consonants and vowels is the node they are attached to, onset and nucleus respectively. The important question is why sonorants do not have their voiceless counterparts like obstruents.

⁵⁵ The elemental composition of sonorants will be discussed in section 3.5. In this section, the relevant discussion about the differences between obstruents and sonorants is dealt with.

⁵⁶ Scheer's Lateral theory (2004) explicitly shows a way, but this would mean taking his whole theory of syllable structure and explaining his complicated machinery, since Sheer's branch of GP is quite different from the branch used in this thesis.

Representing sonorants in the branch of the rhyme could have been a way for differentiating them from obstruents structurally. Let us see why branching rhymes cannot be used for making representations of sonorants different from that of obstruents. Although some sonorants could be in the branch of a rhyme in some words e.g. *kurt* ‘wolf’, claiming the use of branching rhymes does not account for all the distribution of sonorants. There are stem-final sonorants e.g. *gül* ‘rose’ and suffix-initial sonorants e.g. *ev-ler* ‘house+Pl.’, which cannot be represented in branching rhymes because there is no onset to govern the branch of the rhymes. Consider the following illustrations to make this point clearer:

(47) a. <i>kurt</i> ‘wolf’ R \ O ₁ N ₁ \ O ₂ N ₂ \ [x x ◀ x x x] k u r t	b. <i>gül-ü</i> ‘rose+Acc.’ R \ *O ₁ N ₁ \ O ₂ N ₂ \ [[x x x] ✗ x] g ü l ü	c. <i>at-l</i> ‘horse+with’ R \ *O ₁ N ₁ O ₂ N ₂ \ O ₃ N ₃ \ [[x x x x] x x] a t l l
---	---	---

(47 a) has a branching rhyme whose head is the first nucleus. The branch of a rhyme is governed by the following onset O₂ according to Coda Licensing Principle (Kaye, 1990). As can be seen in (47 b), the branch of a rhyme cannot be governed by O₂ since it does not have a skeletal point. That is why, the structure is unacceptable. Also, in (47 c), there is an empty nucleus which is not p-licensed. Also, *l* cannot be the branch of the rhyme since it does not have a head or an onset following it. As a result, representing sonorants in the branch of a rhyme would not explain why the element H does not spread to suffix-initial sonorants.

3.4. Representation of Fricatives

In Turkish, unlike some other languages like German, fricatives do not show voicing alternations in stem-final or suffix-initial positions. For this reason, there are not many phonological processes that can be used to determine the representations of fricatives in Turkish. Nevertheless, the elements proposed to represent voice in plosives provide us with the tools necessary to represent the elemental composition of fricatives.

There is no consensus on how to represent friction in GP, which is similar to the case of representing voice as discussed in section 3.3.1. Some GP researchers like Brockhaus (1999) and Nasukawa (2000) use a special element, *h*, to represent friction, while some others use the *H* element as a head or an operator to represent friction. The *h* element is not one of the elements in the inventory of elements in the Revised Theory, and thus not available in this study. As explained in section 2.4, the properties of elements *h* and *H* are unified in the *H* element in the branch of GP we are following in this study.

In GP, it is not possible to have the same element twice in any role in the composition of an expression. Therefore, when voicelessness is represented with the *H*-operator, *H*-head cannot be used to represent friction in a language which has voiceless fricatives. For example, *s* in a Turkish word *kes* ‘cut’ would have to be represented as (H.A.H), which is not acceptable in Element Theory, as described in section 2.4. Another reason why *H* cannot be used for representing friction is that we would have to use *H*-head to represent friction, which would be a problem when we come to consider the governing relationship between word-final consonants in

Chapter 4. Therefore, in this study, friction is represented by the lack of the stop element ʔ .

3.4.1. Voiced fricatives

There are three voiced fricatives in Turkish. As mentioned in section 2.4.1, the role of an element either as a head or operator can be used to represent properties of different consonants. Since r is represented as containing the A element, representing z as A-headed makes it different from r without adding more elements. The true palatal consonant j is also represented as I-headed like the other true palatals. True palatal consonants are generally considered to be I-headed. Voicedness of fricatives is represented by the lack of H as decided in the analysis of voiced plosives in section 3.3.

Consider the proposed representations of voiced fricatives in Turkish:

- (48) z (\underline{A})
 j (A.I)
 v (U)

As can be seen in (48), the lack of the elements H and ʔ characterize the voiced fricatives, in other words, the lack of H represents voicedness, and the lack of ʔ shows friction. Only the elements A, I and U are involved in the composition of voiced fricatives. Let us consider the use of voiced fricatives in stem-final positions which is not different from any other position for fricatives:

(49) a. <i>kaz</i> ‘goose’ $O_1 N_1 \quad O_2 \quad N_2$ [x x x x] k a <u>A</u>	b. <i>garaj-da</i> ‘garage+Loc.’ $O_1 N_1 \quad O_2 \quad N_2 \quad O_3 \quad N_3 \quad O_4 \quad N_4$ [[x x x x x x] x x] g a r a a A A I ʔ	c. <i>ev-i</i> ‘house+Acc.’ $O_1 N_1 \quad O_2 \quad N_2 \quad O_3 \quad N_3$ [[x x x x] x] e i U
---	---	---

As can be seen in (49 a), a voiced stem-final fricative is not fortified word-finally. In (49 b), we have a suffix starting with a stop. Although the domain final empty nucleus is parametrically p-licensed, it does not have the effects that it has on the plosives. The suffix-initial stop is also voiced because there is no H element in the stem-final position to spread. As can be seen in (49 c), stem-final voiced fricatives are not fortified since they do not have the stop element ʔ in their compositions. There are examples like *tarz* ‘style’ and *şarj* ‘charge’, where voiced fricatives can be the second consonant of the two in word-final positions. Such examples support the representations of *z* and *j* as headed since they can form a governing relationship with the previous consonant, which will be discussed in Chapter 4.

3.4.2. Voiceless Fricatives

As pointed out above, Turkish stem-final *s*, *ş* and *f*, unlike plosives, do not alternate with their voiced counterparts *z*, *j* and *v*. German stem-final voicing alternations differ from Turkish in terms of the behavior of fricatives according to the present analysis. The reason why Turkish fricatives do not have voicing alternations is that voiceless fricatives have an H-operator whether or not the final nucleus is silent. Below are the proposed representations of voiceless fricatives in Turkish, which are

like other non-alternating plosives which are voiceless; in other words, H is already there.

- (50) *s* (A.H)
f (U.H)
h (H)
ʃ (A.H.I)

The element H is used as an operator to express voicelessness both in plosives and fricatives. Coronicity of *s* is represented by using the element A, and labiality of *f* is expressed by using the element U. The true palatal *ʃ* is represented with the use of the I element as a head, like the other true palatals. Also, the H element is the only element in the composition of *h*, and it does not have a voiced counterpart like other voiceless fricatives.

As discussed earlier, final silent nuclei are weak, and phonetically interpreted nuclei are strong. Although stem-final voiceless fricatives do not undergo voicing alternations like final voiceless plosives, they trigger suffix-initial voicing alternation since H in their composition spreads to a suffix-initial onset containing ?-head in its representation. The examples below are given to demonstrate the use of voiceless stem-final fricatives before different suffixes:

(51) a. *savaş-ta* ‘war+Loc.’ b. *şeref-i* ‘honor+Acc.’ c. *ev-siz* ‘homeless’

$O_1N_1 \ O_2 \ N_2O_3 \ N_3 \ O_4 \ N_4$ [[x x x x x x] x x] s a v a l l a H→ A A ʔ I	$O_1N_1 \ O_2 \ N_2O_3 \ N_3 \ O_4 \ N_4$ [[x x x x x x] x] ş e r e l i U H	$O_1N_1 \ O_2 \ N_2O_3 \ N_3 \ O_4N_4$ [[x x x x] x x x x] e l l i z U A H
--	---	---

In (51 a), the H element denoting voicelessness spreads from O_3 to O_4 just like H spreading from stem-final plosives to suffix-initial plosives. However, in (51 b), H is in the composition of O_3 although it is followed by a vowel, which shows that it is not added to fortify the stem final position, but it is there in the first place. Similarly, in (51 c), voicelessness of O_3 cannot be triggered by O_2 because *s* is preceded by a voiced fricative *v*.

3.5. Representation of Sonorants

The nature of sonorants was briefly discussed in section 3.3.2 because of the fact that the voiceless element H does not spread to sonorants. It needs to be pointed out that sonorants, like vowels, are spontaneously voiced. This fact is captured in our representations since H is used to represent voicelessness, rather than L being used for voicedness. That is to say, the representation of voicelessness with H reflects the behavior of sonorants. Sonorants and voiced fricatives in the stem-final positions affect the suffix-initial stop in the same way, that is, nothing spreads to the suffix, and thus they do not trigger any voicing alternations since they do not have H in their compositions.

3.5.1. Nasal Sonorants

Cobb (1997) discusses that since the element L can be used to represent both nasality and voicedness, the element N, which is used by Nasukawa (2000), is redundant. In present analysis, L represents only nasality as an operator since voice is represented by the lack of H. Considering that having L is enough to represent the category of nasals, there is no need to add η to the representations of nasals in Turkish although nasals in some languages are represented with the stop element η .⁵⁷ The element η is used in the representation of nasal expressions in languages, such as English by Ploch (1996), or Korean by Kim (1996) where nasal consonants have special properties as final consonants. In Turkish, it is not possible to have η in the representations of nasals, which is reflected in the licensing constraint stating that “ η must be head”. Namely, having η -head in the composition of nasals does not account for the cases where nasals are the first of the two adjacent word-final consonants as will be discussed in Chapter 4. The following are the proposed representations of nasals:

- (52) [ŋ] (L)
 n (A.L)
 m (U.L)

⁵⁷ Aksan et. al. (1978) and Demircan (1979) discuss “partial assimilation” in that *n* is realized as *m* before *b* in words like *onbaşı* [ombası] ‘sergeant’, and *cünbüş* [džümbüş] ‘entertainment’. These phonetic changes in spoken language are not in the domain of this study. Yet, U-licensing could be proposed to account for such examples within this framework.

The velar nasal is represented by using only the nasal element L, while *n* is represented with the addition of A for coronal, and *m* is represented with U to express its labiality. Note that [ŋ] is used only before the velar stops *k* and *g* in Turkish.

3.5.2. Non-nasal sonorants

In the representation of *r*, only the element A is used. The true palatal *y* is headed like the other true palatals mentioned earlier. Consider the following representations proposed for sonorants:

- (53) *y* (I)
 r (A)
 l (A.U)

In order to make *l* different from *r*, which is represented as (A), another element should be considered in the composition of *l* since it is not possible to have either *r* or *l* headed because of their behavior in word-final clusters. Generally in the representation of *l*, the element ? is considered to be in the representation (Ploch, 1996; Kim, 1996). However, in our analysis, ? cannot be in the composition of *l* because of the licensing constraint in Turkish stating that “? must be head”. This would have two consequences.⁵⁸ Firstly, if *l* had a stop head, it would be a problem for governing relations. Secondly, since the stop element has only one role, namely

⁵⁸ Aksan et. al. (1978) and Demircan (1979) claim “progressive assimilation” in words like *günler* [günner] ‘day+Pl.’ *yanlış* [yannıf] ‘wrong’. Such processes are not significant for this phonological study and will not be dealt with here.

as head, *l* and *d* would have the same representation: (A.ʔ). The only possibility seems to be using the element U⁵⁹.

The decision about which elements should be used especially in the representation of sonorants will be much clearer in the following chapter, where we discuss the relationship between word-final consonant clusters in Turkish.

3.6. Conclusion

In this chapter, the main proposal is the elemental composition of Turkish consonants, which is determined by discussing two voicing alternation phenomena in Turkish. Different possibilities of representing voice in Turkish are considered, and the hypothesis in which H represents only voicelessness is chosen because it is claimed that it is the one that accounts for voicing alternations in Turkish. Section 3.3 constitutes the major part of the chapter since representation of voice also makes it possible to propose representations of fricatives as discussed in section 3.4, and sonorants as discussed in section 3.5.

The following is the chart of representations of Turkish consonants⁶⁰ given in section 3.0, the introduction of this chapter. These representations seem to account for the voicing alternations and other processes related to Turkish consonants. They have been suggested after discussing the relevant phenomena that require a certain elemental composition.

⁵⁹ Denwood (1997 b) also represents *l* as (A.U) in Khalkha Mongolian for different reasons.

⁶⁰ Palatalized consonants will be discussed and represented in Chapter 5.

(48)	Stops	Affricates	Fricatives	Sonorants
Voiced	<i>b</i> (U.?) <i>d</i> (A.?) <i>g</i> (?)	<i>c</i> ((A.?) <u>I</u>)	<i>z</i> (<u>A</u>) <i>j</i> (A. <u>I</u>) <i>v</i> (U)	[ŋ] (L) <i>n</i> (A.L) <i>m</i> (U.L) <i>y</i> (<u>I</u>) <i>r</i> (A) <i>l</i> (A.U)
Voiceless	<i>p</i> (H.U.?) <i>t</i> (H.A.?) <i>k</i> (H.?)	<i>ç</i> ((H.A.?) <u>I</u>)	<i>s</i> (A.H) <i>f</i> (U.H) <i>h</i> (H) <i>ş</i> (A.H. <u>I</u>)	

The elemental composition of consonants above helps us determine natural classes in Turkish. All the elements containing the ?-head are stops, all I-headed expressions are palatals, the expressions having both ? and I-headed are complex segments i.e. affricates, all expressions having the L element in their representations are nasal, all the consonants containing H but not ? are voiceless fricatives, the consonants containing ? but not H are voiced stops or affricates.

The only categories we have difficulty differentiating from each other are voiced fricatives and non-nasal sonorants. It cannot be assumed that all voiced fricatives are headed since *v* is headless because of the relationships between two final consonants. As stops and affricates are related to each other by the presence of ?-head, voiced fricatives and sonorants other than nasals form a natural class since they both lack H and ? elements in their composition. Other than the compositional similarity, they behave the same way in the stem-final positions in that they have no effect on the following suffix-initial consonant. Consider the following categories of consonants in Turkish in the light of discussions above:

(49) a. ?-headed	<i>t</i>	<i>d</i>	<i>k</i>	<i>g</i>	<i>p</i>	<i>b</i>
b. I-headed	<i>ʃ</i>	<i>j</i>	<i>y</i>			
c. Complex segments	<i>ç</i>	<i>c</i>				
d. A-headed	<i>z</i>					
e. Headless	<i>r</i>	<i>l</i>	<i>v</i>			
f. Headless with L	[ŋ]	<i>n</i>	<i>m</i>			
g. Headless with H	<i>s</i>	<i>f</i>	<i>h</i>			

In (49), the chart in (48) is reorganized in terms of the composition of each consonant. In (49 c), a “complex segment” refers to affricates which have both ? and I as heads.

The representations in (48) will also help us deal with word-final consonant clusters and the interaction between consonants and vowels, which will be the topic of the next two chapters respectively. Both of these issues are directly related to the elemental composition of Turkish consonants.

CHAPTER 4

WORD-FINAL CONSONANT CLUSTERS IN TURKISH

4.0. Introduction

In this chapter, the nature of consonants occurring in word-final clusters will be discussed in relation to their elemental composition suggested in Chapter 3. The term “consonant cluster” is informally used in this study to mean phonetically adjacent onsets although they can never be structurally adjacent because of the existence of a p-licensed empty nucleus. According to TELL⁶¹, there are 690 words⁶² ending in word-final consonant clusters in Turkish, which will be accounted for in this study.

Let us consider examples of permitted types of words with final consonant clusters, which are organized according to the first of the two final consonants:

- (1) a. *park* ‘park’ *kart* ‘card’ *harp* ‘war’ *farz* ‘duty’
 harç ‘tuition’ *marş* ‘anthem’ *form* ‘form’ *modern* ‘modern’⁶³

⁶¹ Turkish Electronic Living Lexicon is a database of 30,000 Turkish words representing both printed dictionaries and actual speaker knowledge by the Linguistics Department at the University of California, Berkeley.

⁶² Some of these consonant clusters are not pronounced as clusters by Turkish speakers such as the words with the suffix *-izm* as in *Kemalizm*. In the dialect being analyzed here, it is pronounced as [kemalizim].

⁶³ Speakers of Turkish with little or no formal education might pronounce these words with a vowel between *r* and *n/m* as in [moderen].

- b.⁶⁴ *kalk* ‘get up’ *alt* ‘bottom’ *kalp* ‘heart’ *felç* ‘stroke’
 vals ‘waltz’ *film* ‘film’
- c. *tank* ‘tank’ *ant* ‘promise’ *şans* ‘luck’
 sem ‘neighbourhood’ *kamp* ‘camp’ *zamk* ‘glue’ *şems* ‘sun’
- d. *zift* ‘tar’ *taht* ‘throne’ *şevk* ‘enthusiasm’
- e. *hoşt* ‘go away’ *aşk* ‘love’
- f. *kask* ‘helmet’ *üst* ‘top’ *gasp* ‘seizure’
- g. *aks* ‘reflection’ *faks* ‘fax’

In (1 a) and (1 b), the non-nasal sonorants *r* and *l* precede obstruents and nasals. In (1 c), the nasals [ŋ], *n* and *m* are followed by plosives and the fricative *s*. The reverse plosive-sonorant order in word-final consonants is not found in the language as in **metn*. The acceptable counterpart of this form in Turkish is *metin* ‘text’. There is a vowel between these two consonants although in the original language⁶⁵ of these loan words, there might not be a vowel. In (1 d, e and f), we have fricatives as the first consonants of the clusters and plosives as the second. In (1 g), however, the stop *k* is followed by *s*. As can be seen in (1 a, b, c, d and e), consonants are in a certain order in word-final consonant clusters. In (1 f and g), either order is observed with *s* and *k*. That is, *s* can be either the last consonant or the first consonant of the word-final cluster.

⁶⁴ The consonant cluster in *sulh* ‘peace’ is acceptable due to the fact that [h^j] is equally complex as a palatalized consonant containing I-operator. Palatalized consonants will be discussed in detail in Chapter 5.

⁶⁵ In some dialects of modern Arabic, the pronunciation is like Turkish. Classical Arabic and some modern dialects allow consonant clusters that are not allowed in Turkish.

There are unacceptable word-final consonant clusters, e.g. **mn*, **nm*; **çt*, **tç*. Although both *m* and *n* can be the first consonant in clusters when followed by plosives, they cannot be in the second onset of the cluster after consonants except for *r* and *l*. Likewise, *ç* and *t* can be in the second onset of clusters, but not the first one, so they cannot both occur together.

In the first section of this chapter, the status of the empty nuclei trapped between last two onsets of the word is dealt with. Section 2 addresses the question of which consonants can be good governors, which consonants can be good governees, and how their elemental composition determines their roles in the governing relationships. In the third section, the discussions will focus on clusters involving *s* and *ʃ* in which either order is possible unexpectedly. Finally, the findings of this chapter are summarized in section 4.

4.1. Empty nuclei trapped between two onsets

GP as proposed by KLV (1990) can be differentiated from other frameworks in allowing empty positions in the structure. In GP, nuclei are always present in lexical representations even when they are empty and uninterpreted, and whether or not empty nuclei are phonetically interpreted is determined by the Phonological ECP as first given in 2.3 and repeated below:

(2) The Phonological ECP (Kaye, 1990):

A p-licensed nucleus is not phonetically interpreted.

P-licensing: i. Domain-final nuclei are parametrically p-licensed

e.g. English and Turkish ON; Italian and Japanese OFF

ii. Properly governed empty nuclei are p-licensed.

iii. A nucleus in an onset-onset governing domain is p-licensed.

iv. Empty nuclei licensed by ‘Magic’ licensing are p-licensed.

Proper government: α properly governs β if:

i α and β are adjacent on the relevant projection,

ii. α is not itself p-licensed, and

iii. there is no governing domain separating α from β .

As the phonological ECP states, an empty nucleus can remain uninterpreted when it is domain-final in a language where final empty nuclei are parametrically p-licensed, when it can be properly governed by the following interpreted nucleus, and when it is within an inter-onset government domain. Consider the following concrete examples with structure:

(3) a. *ev-de* ‘home+Loc.’

O_1N_1	O_2N_2	O_3N_3
[x x	x x]	x x]
e v	d e	

b. *abla* ‘sister’

	x ← x		
O_1N_1	O_2	N_2O_3	N_3
[x x	x x	x x	x x]
a b	l a		

c. [xamt] ‘together’
(Khalkha Mongolian)

O_1N_1	O_2	N_2O_3	N_3
[x x	x x	x x	x x]
x a	m	t	
	x ← x		

In (3 a), N_2 is a domain final empty nucleus which is parametrically p-licensed. The locative suffix is analytically combined with the stem. The brackets show that the locative suffix and the stem combine analytically (dependent analytic morphology). In (3 b), N_2 is an empty nucleus in word-medial position which needs to be properly governed to remain silent. Since N_3 is phonetically interpreted, it can govern N_2 . In (3 c), an example from Khalkha Mongolian (Denwood, 1997 b) is given to show the inter-onset government relationship between O_2 and O_3 . All these government relationships create “phonetically” adjacent consonants. However, in some languages, there could be “structurally” adjacent consonants through,

- (4) i. constituent government in a branching onset
- ii. inter-constituent government between the branch of a rhyme and the following onset

Note that all the government relations require a certain order of consonants depending on their elemental composition. A cluster created by a branching onset can be seen in the English example below:

(5) drop

$$\begin{array}{cccc}
 O_1 & N_1 & O_2 & N_2 \\
 / \backslash & | & | & | \\
 x \rightarrow x & x & x & x \\
 | & | & | & | \\
 d & r & o & p
 \end{array}$$

In (5), O_1 is a branching onset, which is governed in a left-to-right constituent government relationship, as illustrated with an arrow.

The second way of accounting for consonant clusters in GP would have a structure where a branching rhyme is followed by an onset according to the Coda Licensing Principle by Kaye (1990). As seen in section 2.1, inter-constituent government could be proposed between the stem-final consonant and the branch of a rhyme. Consider the following example from English:

(6) milk

$$\begin{array}{cccc}
 & R & & \\
 & | \backslash & & \\
 O_1 N_1 \backslash & O_2 N_2 & & \\
 | | \backslash & | | & & \\
 x & x & x \leftarrow x & x \\
 | & | & | & | \\
 m & i & l & k
 \end{array}$$

In (6), the branch of the rhyme l is governed by O_2 . In this case, of course there would be no intervening empty position to remain silent. However, in Turkish, there are some word-final consonant clusters like *semt* ‘neighborhood’ and *zank* ‘glue’, which cannot be accounted for by inter-constituent government, since m is not homorganic with the following consonant, i.e. we expect words like *semp*, *sent* and [zaŋk], and cannot be represented in the branch of a rhyme governed by a following

onset.⁶⁶ The combination of the two structures given in (4 i) and (4 ii) can create clusters consisting of three consonants as in *poultry*, where *l* is the branch of a rhyme having an inter-constituent governing relationship with *t*, and *t* and *r* are in a constituent government relationship as a branching onset.

The elemental composition of Turkish consonants proposed in Chapter 3 will allow us to make certain predictions about what is likely to occur in a final ‘cluster’. The term “word-final cluster” here is used in the sense of ‘phonetically adjacent’, which can be brought about through an inter-onset government relationship between two onsets separated by a silent empty nucleus.

First of all, in this study, it is claimed that Turkish does not have branching rhymes because of non-homorganic nasals in word-final clusters. Also, there are no clusters in the word which are likely to be branching onsets anywhere else but in the middle, and then there could always be proper government of an empty nucleus between the two consonants. It will be discussed in Chapter 5 that there are no word-initial branching onsets in Turkish. There are no branching onsets word-finally in Turkish since “word-final consonant clusters” in words like *psikiyatr* ‘psychiatrist’ are pronounced with a vowel, which proves the impossibility of word-final branching onsets. Additionally, words like *kitap-lar* ‘book+Pl.’ could look like having a branching onset, but *l* can follow any consonant as in *er-ler* ‘soldier+Pl.’ Morphology also shows that the onset *p* belongs to the stem *kitap* and *l* belongs to the suffix.

⁶⁶ Even if the structure of a branching rhyme followed by an onset is used, and these examples were considered as exceptions, we would still need to discuss the characteristics which make good governors and governees for inter-constituent relationships. Although there are cases where nasal is homorganic with the following consonant as in [kent] ‘city’, it is not possible to claim inter-constituent government for some examples and inter-onset government for the others since they seem to belong to the same phonological process.

In this study, it will be claimed that word-final consonant clusters in Turkish consist of two consonants separated by an empty nucleus, and that the elemental composition of the two consonants will determine whether or not the empty nucleus is phonetically interpreted. Consider the following illustrations:

(7) a. *halk* ‘public’

O ₁	N ₁	O ₂	N ₂	O ₃	N ₃
[x	x	x	x	x	x]
h	a	l		k	
x	←	x			

b. **akl*

O ₁	N ₁	O ₂	N ₂	O ₃	N ₃
[x	x	x	x	x	x]
a	k				
x	←	X	x		

As can be seen in (7 a), it will be proposed that the empty nucleus between two onsets can remain silent only if the right hand consonant in the word-final cluster has the characteristics to make a good governor, and the left hand one has the properties of a good governee. When we have the reverse order as illustrated in (7 b), the structure is ill-formed. When the empty nucleus is not governed, it is phonetically realized. In Turkish, the word is *akıl* “intelligence” since there is no governing relation between O₃ and O₂. In Turkish, empty nuclei are phonetically interpreted as [i] and its three vowel harmony counterparts: [i, u, ü]. The elemental composition of Turkish consonants discussed in Chapter 3 will be used to determine good governors and governees.

4.2. Governors and Governees

In this study, it is claimed that the empty nucleus in word-final clusters is p-licensed by inter-onset government in Turkish. In GP, governing relations between two onsets

are determined by the composition of phonetically adjacent consonants. Kim (1996) claims that in Korean, headed expressions are governors and headless expressions are governees, but headless expressions can govern other headless expressions if they are equally or more complex. In Korean, inter-onset government is head-initial. Unlike Korean, inter-onset government in Khalkha Mongolian (Denwood, 1997 b) is right-to-left.

The Complexity Condition was discussed in section 2.5 (Harris, 1990), and its formal definition is repeated below:

(8) Complexity Condition

If α and β are segments occupying the positions A and B respectively, then if A governs B, β must be no more complex than α .

In this study, it is also proposed that the direction of inter-onset government in Turkish is right-to-left as in Khalkha Mongolian, that is, the governee is the left-hand consonant in the stem-final clusters, and the governor is the right-hand one. Consider the following example:

(9) *sarp* ‘steep’

O_1N_1	O_2	N_2O_3	N_3
[x	x	x	x x x]
s	a		
	A	U	
		H	
		ʔ	
	x	←	x

Inter-onset government

In illustration (9), N_2 cannot be p-licensed by N_3 by proper government since N_3 as a domain final empty category is parametrically p-licensed in Turkish, and according to the ECP, it is not itself a potential proper governor. Therefore, for N_2 to remain silent, inter-onset government is needed, which is possible since O_3 is headed, which makes it a good governor. O_2 makes a good governee since it is headless. The inter-onset government relationship between skeletal points is shown at a projection to explain inter-onset government more clearly.

In order to determine good governors and governees, all the words with word-final consonant clusters listed in TELL have been considered. Depending on the frequency of words with word-final clusters, the list of possible and impossible governors and governees in Turkish is given below.

- (10) i. Possible governors *p, t, k, ʧ, z, j, ʒ, f, s, n, m*
 ii. Possible governees *l, r, [ŋ], n, m, s, h, f, v*

It should be noted that not all potential governees precede all potential governors. The reason for this is mainly the elemental composition of these consonants. When we look at possible governors and governees, it can be seen that most consonants can either be a governor or a governee. The reason why *b, d, g* and *c* are missing from the list of good governors in (10 i) is that voiced stops and affricates are not found word-finally in Turkish.

We observe that the consonants *m, n, s* and *f* can be both governors and governees. However, they can only be governors of equally or less complex headless consonants, as can be seen in (12 a) below. Their headedness does not depend on their position, namely, voiceless fricatives and nasals are always headless, but they

can be governors of *l* and *r* which are equally or less complex. In GP, the order of consonants in word-final clusters follows the Complexity and Headedness principles. In other words, when governors are headed, it does not matter if governees are more complex or not; whereas, when governors are headless, they have to be equally or more complex than their governees according to the Complexity Condition. In Turkish, according to the representations suggested in this study, all governors except *s* and *f* are headed, and all governees are headless.⁶⁷ The unique behavior of *s*, which was mentioned in relation to other languages in section 2.2.3, will be discussed in section 4.3 in relation to Turkish.

4.2.1. Acceptable order of consonants

In (11) below, examples are provided to show which governees are allowed for each governor⁶⁸ in word-final consonant clusters:

⁶⁷ In words like *zapt* ‘capture’, the first consonant of the two is a headed stop, which is not a property of a good governee. Since inter-onset government is not available according to representations of consonants in this study, such words could be regarded as exceptions. However, it should be noted that *zapt* is not generally used alone; it is used with the verb *et-* ‘do’, whose vowel can properly govern the empty nucleus. The cases of vowel-zero alternation *katil - katil-i* ‘murder+Acc.’ before the verb *et-* as in *katlet-* ‘to murder’ support the proper government analysis of *zapt*.

⁶⁸ The examples with *s* as a governor of a stop as in *aks* ‘axle’ and *ş* as a governee as in *aşk* ‘love’ will be given and discussed in section 4.3.

- (11) a. *zift* ‘tar’ *kart* ‘card’ *kist* ‘cist’,
 rant ‘interest’ *alt* ‘bottom’ *taht* ‘throne’
- b. *ilk* ‘first’ *tank*⁶⁹ ‘tank’ *zamk* ‘glue’
 kask ‘helmet’ *kırk* ‘forty’ *sevk* ‘transfer’
- c. *kalp* ‘heart’ *kamp* ‘camp’ *harp* ‘war’
 gasp ‘seizure’
- d. *inanç* ‘faith’ *felç* ‘stroke’ *harç* ‘tuition’

In (11), all words have plosives as the second member of the cluster.

- (12.) a. *arz* ‘demand’ *şarj* ‘charge’ *harf* ‘letter’
 marş ‘anthem’ *hürs* ‘ambition’ *şems* ‘sun’
 balans ‘balance’ *vals* ‘waltz’
- b. *form* ‘form’ *modern* ‘modern’ *film* ‘film’

In (12 a), fricatives and in (12 b) nasals are the second consonant of clusters. While plosives in (11), as headed expressions, can follow almost all governees, fricatives only follow the sonorants *m*, *n*, *r* and *l*, and nasals can only follow the liquids *r* and *l*. All these consonant clusters above will be accounted for by using inter-onset government. Since it is claimed that the elemental composition of consonants will determine governing relations, the representation of Turkish proposed consonants in section 3.6 is repeated below:

⁶⁹ *n* in *tank* is a velar nasal that is represented as [ŋ] phonetically.

(13) Elemental composition of Turkish consonants

	Stops	Affricates	Fricatives	Sonorants
Voiced	<i>b</i> (U.ʔ) <i>d</i> (A.ʔ) <i>g</i> (ʔ)	<i>c</i> ((A.ʔ)(I))	<i>z</i> (A) <i>j</i> (A.I) <i>v</i> (U)	[ŋ] (L) <i>n</i> (A.L) <i>m</i> (U.L) <i>y</i> (I) <i>r</i> (A) <i>l</i> (A.U)
Voiceless	<i>p</i> (H.U.ʔ) <i>t</i> (H.A.ʔ) <i>k</i> (H.ʔ)	<i>ç</i> ((H.A.ʔ)(I))	<i>s</i> (A.H) <i>f</i> (U.H) <i>h</i> (H) <i>ş</i> (A.H.I)	

All the headed consonants represented in (13) are predicted to be good governors. Although voiced plosives are good governors, Turkish does not normally have them word-finally (see section 3.3.1.4). Headed voiced fricatives *z* and *j*, the voiceless fricatives *f* and *s*, and the nasals *m* and *n* can be good governors. The sonorant *y* is headed as a true palatal, but it is never in the second part of a cluster. On the other hand, all the headless consonants can be good governees. It should be emphasized that headed expressions cannot be governees.

Let us consider some examples of permitted consonant clusters with the elemental composition of the consonants making up these clusters:

(14) a. *alt* ‘bottom’

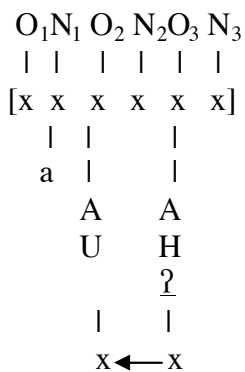

b. *Türk* ‘Turk’

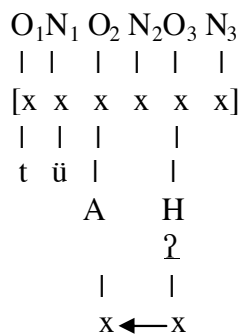

c. *turp* ‘radish’

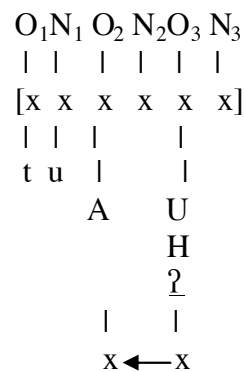

In (14), governors are voiceless stops, which are ʔ-headed. The consonants preceding the governors are all headless, which make them good governees. When these good governors and good governees come together in an inter-onset government domain, they allow the empty position to remain silent. The examples in (15) below demonstrate how an expression can be used either as a governee or a governor with different consonants:

(15) a. *zift* ‘tar’ b. *zarf* ‘envelope’

O ₁ N ₁ O ₂ N ₂ O ₃ N ₃	O ₁ N ₁ O ₂ N ₂ O ₃ N ₃
[x x x x x x]	[x x x x x x]
z i	z a
U A	A U
H H	H
ʔ	
	x←x
x←x	

(15 a) shows the use of a fricative as a governee of a stop, and since *t* is headed, it is a good governor. In (15 b), although *f* is headless, it is still more complex than *r*, which makes it a good governor in this context. In addition to clusters with *f*, there are also examples of with *s* as a headless governor like *hirs* ‘ambition’ or *Kars* ‘a city in Turkey’ in which *s* governs *r* since *s* is more complex.

4.2.2 Unacceptable order of consonants

Let us look at combinations of consonants which are unacceptable as word-final clusters. This can also be explained by the elemental composition of the consonants concerned.

(16) a. **satr* ‘line’

O ₁	N ₁	O ₂	N ₂	O ₃	N ₃
[x	x	x	x	x	x]
s	a				
		A		A	
		H			
		<u>?</u>			
x		x		x	

b. **katl* ‘murder’

O ₁	N ₁	O ₂	N ₂	O ₃	N ₃
[x	x	x	x	x	x]
k	a				
		A		A	
		H		U	
		<u>?</u>			
x		x		x	

c. **izn* ‘permission’

O ₁	N ₁	O ₂	N ₂	O ₃	N ₃
[x	x	x	x	x	x]
		i			
		<u>A</u>		A	
				L	
		x		x	

The words in (16) are actual words in Turkish borrowed from Arabic, but they do not have word-final consonant clusters in Turkish. The empty nucleus N₂ is not licensed in an inter-onset government relationship, and thus phonetically interpreted in Turkish as *satır*, *katıl*, and *izin*. The reason for this is that first consonants in the clusters are not good governees since they are headed expressions in Turkish. Note that the reverse order of consonants above makes good consonant clusters as in *şart* ‘condition’ and *halk* ‘improper act’.

When two consonants which do not make good word-final clusters are discussed, consonants taking part in vowel-zero alternations in Turkish need to be taken into consideration too. Data on vowel-zero alternation is given in three sets below depending on the last two onsets of the words:

(17)		Nom.	Acc.	
a.	* <i>hayr</i>	<i>hayır</i>	<i>hayr-ı</i>	‘favor’
	* <i>akl</i>	<i>akıl</i>	<i>akl-ı</i>	‘mind’
b.	* <i>emr</i>	<i>emir</i>	<i>emr-i</i>	‘order’
	* <i>tavr</i>	<i>tavır</i>	<i>tavr-ı</i>	‘attitude’

c.	<i>*gönl</i>	<i>gönül</i>	<i>gönl-ü</i>	‘heart’
	<i>*genz</i>	<i>geniz</i>	<i>genz-i</i>	‘sinus’

In (17 a), *y* and *k* are not good governees since they are headed, and *r* and *l* cannot be the governor of a headed expression. In (17 b), *m* and *v* cannot be good governees of *r*, which is less complex than *m* and *v* although they can be governees of a headed stop. As a result, all the words in (17 a and b) are unacceptable as consonant clusters although the source language has a silent empty nucleus between these consonants.⁷⁰ This alternation can be indirectly accounted for by the failure of inter-onset government in that none of the pairs above makes good governees or governors to p-license the empty position by forming an inter-onset government relationship. Therefore, when a suffix starting with a vowel does not provide a proper government, these empty nuclei are not p-licensed and must be interpreted phonetically following vowel harmony. However, the empty nucleus is silent when it is properly governed by the suffix-initial nucleus as in *akl-ı* ‘mind+Acc.’. In (17 c), the empty nucleus is not licensed in the first column although an inter-onset relationship seems to be possible as long as complexity and headedness are concerned. The nature of such cases will be discussed later.

Consider the examples below provided to explain why the empty nucleus between the last two onsets of the word has to be phonetically expressed in (18):

⁷⁰ This shows that either the elemental composition of Arabic is different from Turkish or Arabic has a different set of governing relations, since conditions on the application of the ECP may be different.

(18) a. [akɪl] ‘intelligence’

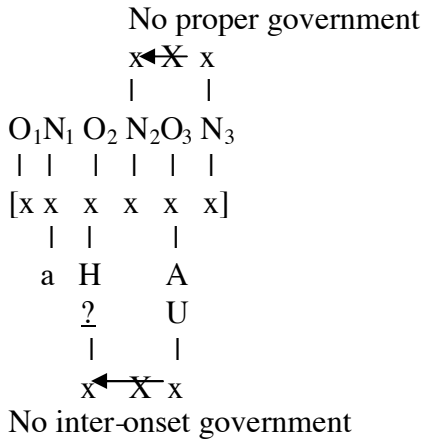

b. [akɪɫ] ‘intelligence+Acc.’

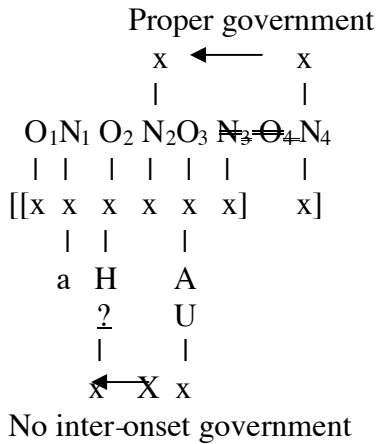

In Turkish, both proper government and inter-onset government are from right-to-left. In the examples in (18), there is no inter-onset government since *k* is not a good governee because it is headed, and *l* does not make a good governor in Turkish since it is not headed. Proper government is not available in (18 a), since the domain final empty nucleus is parametrically p-licensed, and there is no suffix starting with a vowel following the stem. That is why, N_2 is phonetically realized. However, in (18 b), N_2 is properly governed by N_3 , and thus can remain silent.

On the other hand, the order where a headless consonant is followed by a headed consonant or a headless consonant is followed by a more complex headless

consonant does not automatically mean that they are acceptable word-final clusters in Turkish. The consonants *f*, *v*, *l* and *m* below can be good governees and *p*, *j* and *ç* can be good governors, but not all combinations of these groups of words are possible. Let us look at the following made-up words with the elemental representations of their consonant clusters:

(19) a. * <i>avp</i>	b. * <i>afç</i>	c. * <i>alj</i>	d. * <i>amç</i>
O ₁ N ₁ O ₂ N ₂ O ₃ N ₃	O ₁ N ₁ O ₂ N ₂ O ₃ N ₃	O ₁ N ₁ O ₂ N ₂ O ₃ N ₃	O ₁ N ₁ O ₂ N ₂ O ₃ N ₃
x x x x x x	x x x x x x	x x x x x x	x x x x x x
	\		\
a	a \	a	a \
U U	U A <u>I</u>	A A	L A <u>I</u>
H	H H	U <u>I</u>	U H
<u>?</u>	<u>?</u>		<u>?</u>

In (19), all the second consonants in clusters are headed, which makes them good governors. Also, none of the consonants in O₂ is headed, which should make them good governees according to the elemental composition suggested in this study. Note that the consonants occupying O₂ are good governees of a different set of governors, and the consonants in O₃ can be good governors of a different set of governees. This could be due to a lexical gap, or it might have something to do with the languages which loan words come from. The second assumption is based on the claim that some of the words with consonant clusters are loan-words, and the reason why the following words do not exist is that those combinations of word-final expressions do not exist in the source language.

Native speakers of Turkish⁷¹ were asked to pronounce the words in (19) above. Although they considered these words as non-Turkish words, when pronounced, the empty nucleus between the word-final consonants is not phonetically interpreted, i.e. silent, which means those words end in possible clusters. Thus, inter-onset government is at work for these made-up words. The prediction, then, is that if a new word like the ones explained above enters the language, the word-final consonant cluster will be possible and not separated with an interpreted nucleus as long as it follows the principles of inter-onset government.

The order of word-final consonants exemplified in (18) above was also tested with native speakers by using made-up words like *atr*⁷², *izr*, *ipr*, *otl*, *uçr*, *ekr* in which the order of good governees and good governors is reversed. All these words were pronounced with a phonetically interpreted empty nucleus between the consonants, proving that Turkish word-final consonant clusters are regulated by inter-onset government. In other words, *r* and *l* cannot be good governors of headed expressions preceding them, so the empty nucleus between them cannot be p-licensed in an inter-onset government relationship, and thus is phonetically realized.

4.3 Magic Licensing in word-final positions

The fricative *s* behaves unexpectedly in many languages, as discussed in section 2.2.4. In the discussion of good governors and governees in Turkish, *s* is claimed to be a good governee of stops, which are good governors. Also, it is claimed to be a

⁷¹ The same group of subjects mentioned in section 3.3.1.4 were asked to pronounce these words. They all pronounced the words as clusters supporting the claim of this study although they could identify these words as non-Turkish.

⁷² There are some rare final consonant sequences like *guatr* ‘goiter’, *psikiatr* ‘psychiatrist’ listed in TELL, but these words are generally pronounced as [ɡuatır] and [pisikiyatır] in spoken Turkish.

governor of *r*, which is less complex than *s*. However, there are some other clusters involving *s* as the second consonant of the cluster, which cannot be accounted for by inter-onset government.

Consider the following examples of word-final consonant clusters in which *s* is preceded by *k*, which is a headed consonant.

- (20) *boks* ‘boxing’ *faks* ‘fax’ *lüks* ‘luxurious’
aks ‘axle’ *raks* ‘dance’ *indeks* ‘index’

Kornfilt (1997) lists clusters with *k+s* as possible word-final consonant clusters like the other consonant clusters.⁷³ However, it is claimed here that there is a difference between consonant clusters ending with *s* and other possible consonant clusters in Turkish. The empty nucleus before *s* in these words is interpreted by some speakers as in (21 b) below, while for some speakers the empty nucleus between *k* and *s* is licensed to remain silent as in (21 a).

(21) a. [lüks] ‘luxurious’

O ₁ N ₁	O ₂	N ₂ O ₃	N ₃
[x	x	x	x]
l	ü	k	s

b. [lüküs] ‘luxurious’

O ₁ N ₁	O ₂	N ₂ O ₃	N ₃
[x	x	x	x]
l	ü	k	ü
l	ü	k	ü
l	ü	k	s

For the structure in (21 a), it is claimed that because of the special properties of *s*, the empty nucleus preceding it is licensed unexpectedly. In (21 b), the empty nucleus is vocalized following vowel harmony rules, which shows that special properties of *s*

⁷³ Older borrowings like **aks* but *akis* ‘opposite’ are different from more recent borrowings like *aks* ‘axle’.

are not available for the speakers of this dialect. In this dialect, there is only one order possible, where *s* is preceded by *k* following inter-onset government. When the inter-onset government relationship is violated by the presence of a headed consonant in the first onset of a cluster, the empty nucleus between *k* and *s* has to be vocalized. Below, the dialect of native speakers who pronounce the words as in (21 a) will be discussed.

As can be seen in Turkish examples above, the fricative *s* is a consonant that behaves differently from other consonants especially in terms of its odd behaviour in clusters. Considering its irregular use, Kaye (1992) claims that in some languages e.g. English, *s* occupies the branch of a rhyme, and the nucleus position in the rhyme hosting *s* is licensed by Magic Licensing as discussed in section 2.2.4 (Kaye, 1992). Kaye claims that in *s + C* sequences, *s* as in *stop* occupies the branch of a rhyme followed by an onset. This means that *s + C* sequences occupy the structure in (22):

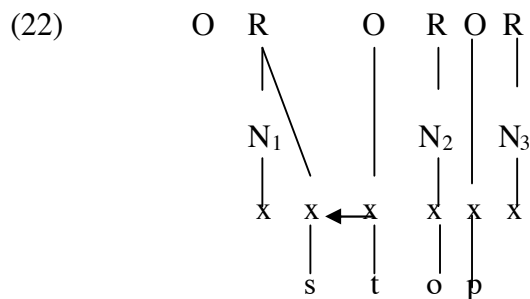

In (22), N_1 needs to be licensed, but N_2 cannot properly govern N_1 because there is a branching rhyme, whose branch needs to be governed by the following onset. Since a branching rhyme is a governing domain, proper government cannot take place across it, there are no means to silence N_1 . N_1 must be licensed as a result of Magic Licensing.

In this study, since it is claimed that Turkish does not have branching rhymes, the question here is whether or not Magic Licensing is a necessary operation in Turkish. If it is, then how Magic licensing operates in a non-branching framework needs to be accounted for.

When the arguments above are considered, Magic Licensing seems to be a very useful tool to account for consonant clusters where *s* follows stops. Originally Magic Licensing was claimed for word-initial clusters, and the nucleus magically licensed would be the head of the branching rhyme in word-initial positions. In this study, the empty nucleus which is magically licensed is the trapped nucleus between *s* and the preceding stop. Since the empty nucleus in that position cannot be licensed either by inter-onset government or proper government, this also seems to be a case of Magic Licensing.

In examples like *lüks* ‘luxurious’, *aks* ‘axle’, and *faks* ‘fax’, where *s* follows a headed voiceless stop which is obviously a good governor, it is not possible to account for the silencing of the empty position by resorting to inter-onset government. As pointed out before, it is not acceptable to have a headed consonant as a governee. There are also words like *test* ‘test’, *kist* ‘cist’ and *kask* ‘helmet’, which have word-final clusters consisting *s* as a governee and a stop as a governor. Since *s* is headless and stops are headed, they make good consonant clusters, which can be accounted for by an inter-onset governing relationship. Let us look at the following words ending in clusters with *s*:

(23) a. <i>kask</i> ‘helmet’	b. <i>şems</i> ‘sun’	c. <i>faks</i> ‘fax’
O ₁ N ₁ O ₂ N ₂ O ₃ N ₃	O ₁ N ₁ O ₂ N ₂ O ₃ N ₃	O ₁ N ₁ O ₂ N ₂ O ₃ N ₃
[x x x x x x]	[x x x x x x]	[x x x x x x]
k a	ş e	f a
A H	L H	H A
H ʔ	U A	ʔ H
x ← x	x ← x	x x ← x

In (23 a), the governor is headed, *s*, as a headless expression, can be a good governee and in (23 b), the governee and the governor are equally complex, which makes it a possible cluster. However, in (23 c), O₂ is headed, which means that it cannot be a good governee, and the empty nucleus cannot remain silent, but it is unexpectedly silent leading to another case of Magic Licensing.

Clusters where stops are followed by *s* are not the only cases of Magic Licensing in Turkish. The consonants *s* and *ş* are similar in nature and behave similarly in many languages. Brockhaus (1999) claims that German word-initial clusters starting with [ʃ] as in *spruch* [ʃprax] ‘saying’ are examples of Magic Licensing. The difference between *s* and *ş* in Turkish is that while *s* is a good governee, *ş* cannot be a good governee because unlike *s*, it is headed. However, there are few examples in which *ş* is the first consonant of a final cluster. Consider the following examples where *ş* is followed by a stop:

(24) a. *aʃk* ‘love’b. *hoʃt* ‘go away’

O ₁ N ₁ O ₂ N ₂ O ₃ N ₃	O ₁ N ₁ O ₂ N ₂ O ₃ N ₃
[x x x x x x]	[x x x x x x]
a	h o
H H	H H
A ʃ	A A
I	I ʃ
x ←x	x ←x

As can be seen in (24), O₂ is headed, which is not the property of a good governee. The only way N₂ can remain silent is Magic Licensing since inter-onset government or proper government cannot operate in these contexts. If we do not want to resort to Magic Licensing explanation for ʃ in the governee position, true palatals should not be represented as headed expressions. Then, we would run into the problem of differentiating true palatals from palatalized consonants (see Chapter 5). The magic licensing account of ʃ is different from the one with *s* in that while with *s*, the preceding empty nucleus is licensed, with ʃ, it is the following nucleus, which is magically licensed.

In summary, clusters where *s* is not a good governor, and ʃ is not a good governee are still grammatical. However, because of the special licensing power involving these two consonants cross-linguistically, the empty nucleus before *s* and after ʃ is p-licensed.

4.4. Conclusion

In this chapter, word-final consonant clusters in Turkish are discussed by claiming that inter-onset government and Magic Licensing account for word-final consonant clusters by following the elemental composition of consonant proposed in Chapter 3. The possible consonant clusters are listed by categorizing the consonants into good governors and governees as shown below:

(25) a. Governees (Only O_1 in a word-final cluster)

r (A)

l (A.U)

[ŋ] (L)

v (U)

h (H)

b. Governors (Only O_2 in a word-final cluster)

p (H.U.?)

t (H.A.?)

k (H.?)

ç (H.A.? (I))

z (A)

j (A.I)

ş (A.H.I)

c. Both governor and governee (Either O_1 or O_2 depending on the other onset)

n (A.L)

m (U.L)

s (A.H)

f (U.H)

All the governees listed in (25 a) are headless expressions. Headed expressions cannot be good governees. In (25 b), good governors are headed. The consonants listed in (25 c) are governors when they are equally or more complex than the governee they are governing. The nasals *m* and *n* can be good governees of obstruents, while *s* and *f* are governed only by stops. In Turkish, both Headedness and Complexity conditions are necessary to account for governor-governee relations. Headedness accounts for most of the cases since most governors are headed, and all governees are headless. Complexity condition accounts only for a few cases where governors are headless. In these cases, they are more complex than their governees.

Besides the listing above, *s* is used after stops too, which cannot be accounted for by inter-onset government. The fricative ζ appears to be the first consonant of a final cluster, but as a headed palatal, it cannot be a good governee. For these two consonants, it is proposed that Magic Licensing accounts for the empty nucleus before *s* and after ζ by allowing the empty nucleus to remain silent.

CHAPTER 5

PALATALIZED CONSONANTS and THEIR INTERACTIONS WITH
VOWELS

5.0. Introduction

The role of palatalized consonants is not considered in Chapter 3, where the elemental composition of Turkish consonants is proposed to account for voicing alternations in stem-final and suffix-initial positions, nor in Chapter 4, where the empty nucleus between two word-final onsets is licensed through inter-onset government. In this chapter, the relationship between palatalized consonants and vowels will be discussed in two positionally different, but phonologically similar phenomena: “the word-initial phenomenon” and “the word-final phenomenon”.

Let us consider the word-initial phenomenon first. There are mainly two dialects when we talk about the pronunciation of the words which have word-initial consonant clusters in the source language. Let us call the dialect in which there is a vowel between the first two consonants, Dialect A (as represented in (1) below), and let us consider the dialect where the first two consonants are phonetically adjacent, Dialect B. Speakers of Dialect B, are usually educated and familiar with the source language, like French or English. In Dialect A, the pronunciation of average educated Turkish people who do not speak the source language of the borrowed words is considered since their pronunciation will not be influenced by the source language in

their speech. For speakers of Dialect A, the way N_1 is phonetically interpreted depends on the nature of neighboring phonological expressions. That is, in Dialect A, N_1 is interpreted as [ɨ], [i], [u] or [ü], e.g. *t[i]ren*. The first aim of this chapter is to determine how N_1 is interpreted in Dialect A. In Dialect B, however, two onsets are pronounced as phonetically adjacent as in *tren*.⁷⁴ Consider some examples of loan words which start with adjacent consonants in their origin languages but N_1 is interpreted in Dialect A:

(1) a. <i>b[i]riç</i> ‘bridge’	<i>b[u]lüz</i> ‘blouse’	<i>B[ü]rüksel</i> ‘Brussels’
b. <i>p[i]laj</i> ‘beach’	<i>p[u]roblem</i> ⁷⁵ ‘problem’	<i>p[i]rens</i> ‘prince’
c. <i>k[u]lüp</i> ‘clup’	<i>k[ɨ]riz</i> ‘crisis’	<i>k[ɨ]ral</i> ‘king’
d. <i>t[ɨ]raş</i> ‘shave’	<i>t[i]ren</i> ‘train’	<i>t[i]riko</i> ‘tricot’
e. <i>d[ɨ]ram</i> ‘drama’	<i>d[ɨ]raje</i> ‘sugar-coated pill’	
f. <i>g[ɨ]ram</i> ‘gram’	<i>g[u]rup</i> ‘group’	<i>g[ɨ]ladyatör</i> ‘gladiator’
g. <i>f[ü]lorit</i> ‘fluoride’	<i>f[ɨ]ragman</i> ‘fragment’	<i>F[ɨ]ransa</i> ‘France’
h. <i>s[ɨ]por</i> ‘sport’	<i>s[i]til</i> ‘style’	<i>s[i]treç</i> ‘stretch’

In (1), the first consonants are stops except (1g and h), which have a fricative in the first onset. All the second onsets are occupied by either *l* or *r* except for (1h). The difference between the words in (1 a-g) and the ones in (1h) is that the former involves a stop or a fricative followed by a sonorant; whereas, the latter consists of *s* and a stop. Also in *s[i]treç*, there seems to be a sequence of three consonants.

In this chapter, we also discuss the word-final phenomenon, which means that

⁷⁴ Since the dialect of people who pronounce a vowel in N_1 will be considered in this study, Dialect B will not be discussed.

⁷⁵ Some speakers of Turkish might pronounce such words with [ɨ].

vowel harmony in suffixes does not only depend on the preceding vowel in the word, but palatalized consonants also play a role in the vowel harmony process. Consider the following examples where vowel harmony does not seem to follow the vowels in the stems as illustrated with the accusative suffix:

- (2) a. *harf-i* ‘letter’ *harb-i* ‘war’ *saat-i* ‘watch’
 b. *hol-ü* ‘aisle’ *rol-ü* ‘role’ *sembol-ü* ‘symbol’
 kabul-ü ‘acceptance’ *golf-ü* ‘golf’

In (2), the suffix is realized as [i] or [ü] although the nuclei of the stem are back vowels. In Turkish, even in “disharmonic” words, suffixes normally harmonize with the last vowel in the stem, e.g. *kitap-lar* ‘book+Pl.’, *kalem-ler* ‘pen+Pl.’ In (2 a), there is [i] in the suffix, while in (2 b), there is [ü] in the suffixes. Note that there seems to be no dialectal difference in this phenomenon.

The outline of this chapter is as follows: In section 1, previous studies done on these two phenomena will be reviewed. In section 2, different models of Turkish vowel harmony will be presented. In section 3, palatalized consonants and I-licensing will be discussed, which are claimed to account for the word-initial and word final phenomena. In section 4, U-licensing will be discussed mainly to explain why we have U in N₁ in the context of the word-initial phenomenon and U in the suffixes in the context of the word-final phenomenon. Finally, the findings of this chapter will be summarized in section 5.

5.1. Previous Studies

The first study on word-initial and word-final phenomena which will be discussed in this section is Yavaş (1980). Yavaş talks about the relationship between consonant and vowel harmony in the framework of feature-based Generative Phonology. He claims that consonants play a more important role than vowels. In that study, he is only interested in high vowels since non-high vowels have more freedom before palatalized consonants. That is, palatality of consonants is not determined by the frontness or backness of the following nucleus, but is a property of the consonants.

Yavaş (1980) discusses “word-initial consonant clusters”, e.g. *p[i]lan* ‘plan’ and “word-final consonant clusters” with vowel/zero alternation, e.g. *vak[i]t* - *vakt-i* ‘time+Acc.’ by proposing rules specifying the contexts that a certain epenthetic vowel is used. His “strength hierarchy” of the rules is velar conditioning (lack of the I element in GP terms), which is the strongest, then lateral conditioning (presence of the I element in GP terms) and the least strong one is harmony. Velar conditioning stipulates that when the first onset is velar, N_1 is interpreted as [i̠] or [u̠] as in *k[i̠]riz* ‘crisis’, while lateral conditioning requires N_1 to have [i] or [ü] as in *p[i]lan* ‘plan’. According to this hierarchy, when velar conditioning and lateral conditioning are in conflict, the former always wins, e.g. *k[u]lüp* ‘club’, *k[i̠]lan* ‘clan’. When lateral conditioning and harmony are in conflict, the former also wins, e.g. *p[i]lak* ‘record’, *go[ɪ̠]-ü* ‘goal+Acc.’.

One of the two problems with this proposal is that it excludes words ending with palatalized consonants other than *l* since these cannot be accounted for by lateral conditioning like *saa[tʰ]*. Also, it lacks tools to explain the round quality of N_1

in words like *b[u]lüz* ‘blouse’. According to his lateral conditioning, **b[ü]lüz* is expected, since velar conditioning would not work with [b].

Clements & Sezer (1982) suggest that in some words, word-initial consonants are responsible for the interpretation of the epenthetic vowel in word-initial “consonant clusters”. They state that the “epenthetic vowel” consistently harmonizes in “backness” with the following root vowel after labial and dental consonants, but it is invariably back after velars. They claim that since an initial velar consonant in such a cluster has the feature [+back], the inserted vowel will be automatically [+back] as in *g[ɨ]rev* ‘strike’. Consider the following illustration:

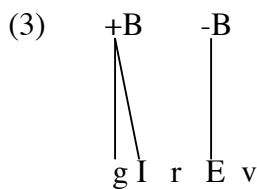

For “roundness” harmony, they observe that the epenthetic vowel may be unrounded before *o* as in *k[ɨ]rom*, but not before *ö* as in *b[ü]löf* ‘bluff’. They propose that if the second nucleus is not rounded, the first one cannot be rounded. Their “roundedness” does not account for all the words of the word-initial phenomenon in a systematic way. Consider the following illustration of *p[i]rens* ‘prince’ to show this proposal:

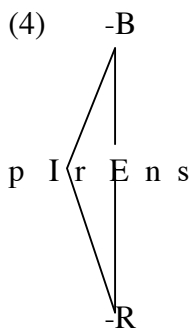

The mirror image case of “Association Convention”⁷⁶, as can be seen in (4), accounts for the phonetic value of the epenthetic vowel in their analysis. They observe that “auto-segmentally represented features” may spread leftward, which shows that vowel harmony is a bi-directional process. The problem with their study is resorting to the feature of the first onset only when it is a velar consonant, but there are cases like *b[u]lüz* “blouse”, where we have a back vowel in N₁ although O₁ is not velar.

Clements & Sezer (1982) also deal with the word-final phenomenon exemplified in (2) above. They state that when the final lateral (*l*) is palatal, front vowel suffixes are required; otherwise, back vowel suffixes are necessary. They represent *l* as an “opaque” segment, which is underlyingly associated with the autosegment [-back]. “Opaque” consonants are claimed to be “non-undergoers”, “blockers” and “spreaders” in their study. In other words, they stop the stem vowel harmony and start a new vowel harmony domain. Consider the following illustration of *kalb-i* ‘heart+Acc.’ below:

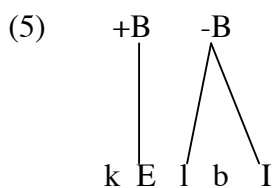

In (5), the autosegment [-back] spreads onto the vowel in the suffix. Clements & Sezer (1982) claim that palatalized consonants [r^j], [t^j], [d^j] and [b^j] also require front vowel suffixes, thus, arguing for “consonant-conditioned vowel harmony” in such cases. They cannot account for examples like *b[u]lüz* either.

⁷⁶ “Association Conventions” show the connections between phonemes and autosegmental features.

Kornfilt (1997) observes that word-initial consonant “clusters” are not permitted in general and broken up in general by “an epenthetic vowel”, which usually undergoes vowel harmony with the stem. She further points out that people in big cities mostly pronounce borrowings with their original word-initial clusters, which is similar to the case in Dialect B in this study. The reason for this might be that those people are familiar with the origins of the borrowed words, which affects their pronunciation.

Göksel & Kerslake (2005) also describe consonants involved in the word-initial phenomenon as consonant clusters “occurring word-initially only in loan words”. They add that [i] or [ɨ] is inserted in or before the cluster by some speakers. Göksel & Kerslake (2005) describe the word-final phenomenon exemplified in (2) above as one of the exceptions to vowel harmony, which happens regularly in loan words that end in a palatal *l*.

The problem with Kornfilt (1997) and Göksel & Kerslake (2005) is that they do not define the problem in its entirety and make only partial descriptions of the two phenomena. Other books on Turkish Phonology do not deal with palatalization directly.

5.2. Harmony in Turkish

It is necessary to discuss how “harmony” works in Turkish in order to understand the interesting behavior of palatalized consonants. In this chapter, the term “harmony” is preferred to “vowel harmony” or “consonant harmony” since it is considered here that in Turkish, harmony is a phenomenon involving both consonants and vowels, as also claimed by Clements & Sezer (1982).

There are three “vowel harmony” analyses done on Turkish in GP, which will be summarized here. The first two studies done by Charette & Göksel (1996, 1998) are theories of spreading and involve the use of licensing constraints as briefly discussed in section 2.4, and the third one is Denwood’s (1997 a) study of harmony which used Turkish as the main illustration of the issues. Specific problems with those accounts that do not relate to our analysis, e.g. having two *e*’s created by licensing constraints (Charette & Göksel, 1998), will not be dealt with here.

5.2.1. Charette & Göksel (1996)

Charette & Göksel (1996) suggest licensing constraints for Turkish, Sakha and Kazakh to explain the conditions on U harmony. Charette & Göksel’s main objective is to make licensing constraints explain why harmonized nuclei do not contain *o/ö*, and the variation between Turkic languages. They do not attempt to explain disharmony, palatalization or why final harmonized empty nuclei occur (e.g. *keci* ‘cat’) even though the domain-final parameter of the ECP predicts that they should be silent. Consider the licensing constraints for Turkish suggested by Charette & Göksel (1996):

- (6) i. U must be head.
 ii. I does not license operators.
 iii. Operators must be licensed.

The vocalic inventory of Turkish following the licensing constraints above is as follows:

(7)	<i>a</i> (<u>A</u>)	<i>u</i> (<u>U</u>)	<i>i</i> (<u>I</u>)	<i>e</i> (<u>I.A</u>)
	<i>o</i> (A. <u>U</u>)	<i>ü</i> (I. <u>U</u>)	<i>ö</i> (A. I. <u>U</u>)	<i>ɪ</i> ()

Note that by following the licensing constraints in (6), all the vowels are headed except [i], which does not contain any elements. In (7), the heads of the expressions are also underlined for uniformity with the rest of the study.⁷⁷

In their study, vowel harmony is considered to be “element spreading”. That is to say, the elements I and U in the first nucleus position spread to the following nucleus positions. Charette & Göksel (1996) assume that non-initial nuclei contain either (A), or nothing (). The I element can spread from a preceding vowel into both (A) as an operator or into () as a head dictated by the licensing constraints; whereas, U from domain head can spread into an empty nucleus as a head, with or without an I operator, but U cannot spread into a nucleus containing (A) because U must be a head, but A is lexically head there. In other words, U can only be the head within an expression. When it spreads to A, which is already a head, it needs to move A into the operator position, which is called “switching”. Their claim is that A cannot be “switched” from head to operator, so U does not harmonize with nuclei containing A in Turkish. That is to say, unlike Sakha and Kazakh, “switching parameter” is OFF in Modern Turkish. Let us consider the following examples to make the explanations above clearer.

⁷⁷ In their paper, Charette & Göksel do not underline heads, but underlining is preferred for clarity here.

- (8) a. *kilim* ‘rug’ $k(\underline{\text{I}})l(\)m \longrightarrow k(\underline{\text{I}})l(\underline{\text{I}})m$
 b. *ev-ler* ‘house-Pl.’ $(\underline{\text{I.}\underline{\text{A}}})v l(\underline{\text{A}})r \longrightarrow (\underline{\text{I.}\underline{\text{A}}})v l(\underline{\text{I.}\underline{\text{A}}})r$
 c. *okul* ‘school’ $(\underline{\text{A.}\underline{\text{U}}})k(\)l \longrightarrow (\underline{\text{A.}\underline{\text{U}}})k(\underline{\text{U}})l$
 d. *olay* ‘event’ $(\underline{\text{A.}\underline{\text{U}}})l(\underline{\text{A}})y$

In (8 a), we observe that the element I as a head in (I) spreads to the empty position as a head. In (8 b), I as an operator in (I.A) can spread to the nucleus position already filled with A-head. In (8 c), U spreads to an empty nucleus similar to (8 a).⁷⁸ However, in (8 d), U cannot spread to a nucleus occupied by A as a head.

In this study, it is claimed that there has to be one set of licensing constraints for both vowels and consonants. Charette & Göksel’s proposals of licensing constraints on Turkish vowels are compared with the ones suggested in this study explaining phonological phenomena involving not only vowels but also consonants. The compatibility and incompatibility of the licensing constraints with those suggested in this thesis will be discussed at the end of section 5.2.2.

5.2.2. Charette & Göksel (1998)

In Charette & Göksel (1996), the impossibility of A spreading in Turkic languages is not explained. Charette & Göksel’s (1998) analysis addresses both this issue and the reason why U does not harmonize A in Turkish, but does harmonize A in other Turkic languages. In their new analysis, they change one of the licensing constraints they proposed in Charette & Göksel (1996). They also look at Kirghiz vowel

⁷⁸ This rule is only true for U-harmonic words. There are some exceptions where there are (A.U) combinations in the second nucleus as in *şoför* ‘driver’. These words can be considered as directly coming from the lexicon as a loan word. There are also words like *tavuk* ‘chicken’ and *kabuk* ‘skin’ in which N₂ and O₂ are claimed to have an interaction (Aksan et. al. 1978).

harmony in this study. The following are the licensing constraints suggested by Charette & Göksel (1998):

- (9) i. U must be head.
 ii. A is not a licenser.
 iii. Operators must be licensed.

In (9), only the second constraint, which is “A does not license operators”, is a new suggestion instead of “I does not license operators”. The vocalic inventory in their (1998) study is the same as the (1996) one, as given in (7) except for the representation of *e* (A.I). Charette & Göksel (1998) claim that A-harmony is not possible in Turkic languages following the licensing constraint stated in (9 ii). This licensing constraint does not only refer to the inability of A to license an operator within its own nuclear expression, but it also refers to the lack of licensing potential of A to harmonize. In other words, A can neither govern operators nor spread to other nuclear positions.

Below are the discussions of how compatible Charette & Göksel’s (1996, 1998) licensing constraints are with the licensing constraints proposed in this thesis.

5.2.2.i. U must be head

The licensing constraints suggested for Turkish in section 3.3 are repeated below. It is claimed in this study that the licensing constraints for consonants should account for the phenomena related to vowels:

- (10) i. ʔ must be head.
 ii. H, L and U cannot be head.
 iii. A is not a licenser.

The licensing constraint “U must be head” suggested in both Charette & Göksel (1996, 1998) is at odds with the licensing constraint “U cannot be head” suggested in this study. First of all, because of the licensing constraint “ʔ must be head”, U cannot be head in *p* and *b* since they are ʔ-headed. Secondly, their first constraint results in representing *m*, *l* and *v* as headed which would not account for inter-onset government in word-final consonant clusters as discussed in Chapter 4. Finally, the representation of vowels adopted in this study does not have U as a head following the constraint “U cannot be head”.

5.2.2.ii. Operators must be licensed

The second licensing constraint which was also suggested in both Charette & Göksel (1996) and (1998) results in having all the expressions headed, but in this study, many expressions must be headless as a result of the inter-onset government relationships. As discussed in Chapter 4, all governees should be headless expressions. As a result of the licensing constraints repeated in (10), the fricatives except for *z*, and the sonorants except for *y* are headless in Turkish, which accounts for the inter-onset government relationship between word-final onsets. This licensing constraint is also at odds with the representation of vowels given in (8) since it stipulates that all the expressions must be headed.

5.2.2. iii. I does not license operators

In Charette & Göksel (1996), the constraint “I does not license operators” was suggested. In our licensing constraints given in (10), there are no licensing constraints limiting the behavior of I, and as a result, I is head in true palatals, and an operator in palatalized consonants. Thus, this licensing constraint fails to account for the difference between true palatals and palatalized consonants. In other words, I can be a licensor in true palatals but cannot be a licensor in palatalized consonants. For the representation of *y*, this constraint accounts for its composition (I), since the element I does not license operators although it is headed. Since vowels are considered to be headless expressions in this study, this constraint does not contradict the representation of vowels. In this study, a licensing constraint is claimed to be the same for both vowels and consonants.

5.2.2. iv. A is not a licensor

This licensing constraint replaced the previous one in Charette & Göksel (1998) in order to account for the observation that A does not spread in Turkish. This is the only licensing constraint that does not contradict with the licensing constraints in this study since A is either an operator in the composition of consonants as in *t, d, s, ʃ* or a head without any operators as in *z*. Also in the representation of vowels, there is no contradiction since headless expressions are not affected by this constraint. This constraint, with the combination of other constraints, explains why A does not spread in Charette & Göksel (1998).

Besides the potential problems mentioned above, Charette & Göksel (1996, 1998) do not have any licensing constraints for the ? and H elements since they analyze only the vocalic system of Turkish. However, in this study, it is claimed that “ ? must be head”, and “H cannot be head”. In the representation of Turkish vowels, the contradictions between the licensing constraints suggested in this study and the licensing constraints suggested by Charette & Göksel (1996,1998) (as given in (6) and (9)) can be avoided by following Denwood’s (1997 a) analysis of vowel harmony.

5.2.3. Denwood (1997 a)

The third harmony proposal for Turkish is made by Denwood (1997 a), and will be adopted in this study because her representation of Turkish vowels does not contradict the licensing constraints given in (10) above. The reason why the composition of vowels is not at odds with our licensing constraints is that she represents all the vowels as headless. According to our licensing constraints, “U cannot be head” and “A does not license operators”, which are compatible with the representation of Turkish vowels. Also, in our licensing constraints provided in (10), there is no licensing constraint stipulating the use of I as head, which is in harmony with her representations.

Denwood’s (1997 a) aim in this harmony theory is to show that harmony phenomena could be accounted for without resorting to licensing constraints. The composition of Turkish vowels used in this study (given in section 2.4), which is proposed by Denwood (1997 a) is repeated below:

(11)	<i>a</i> (A)	<i>u</i> (U)	<i>i</i> (I)	<i>e</i> (A.I)
	<i>o</i> (A.U)	<i>ü</i> (U.I)	<i>ö</i> (A.U.I)	<i>ɨ</i> ()

In (11), all the elements are headless in the representation of vowels. As mentioned in the licensing constraints in section 3.3, there are no constraints on the headedness of the elements A, I and U, which form the vowels in Turkish. In other words, suggesting headless vowels does not clash with the composition of consonants discussed in Chapter 3. It should be noted that [ɨ] is composed of no elements; that is why, it is the interpretation of an empty nucleus when there is no other possible element to be interpreted.

In order to explain why A and U never combine in a non-initial nucleus, she proposes that there are only two possible specifications for a non-initial nucleus which are (A.I) and (U.I). In Denwood (1997 a), vowel harmony is considered to take place in the Lexicon, which means there is no spreading.

According to Denwood's (1997 a) view of harmony, there are two types of nuclei:

- (12)
- i. there are independent nuclei whose content is not restricted, like the N_1 in (13),

 - ii. there are dependent nuclei whose content is subject to constraints on the licensing of their content, like the N_2 in (13).

In Denwood's (1997 a) analysis, I and U do not spread, but when they are lexically present in dependent nuclei, they cannot be interpreted without a license, which is

given by the same element in a nucleus (harmonic domain head) which governs dependent nuclei. The following illustrations from Denwood (1997 a) are provided below to clarify our summary of her analysis:

(13) a. *beşik* ‘cradle’

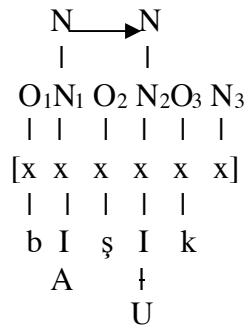

b. *buruk* ‘twisted’

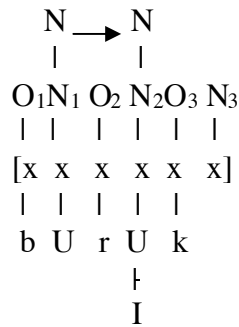

c. *höyük* ‘mound’

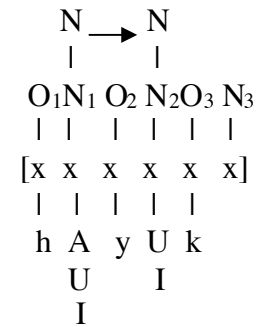

The examples in (13) are all I-harmonic words. In (13 a), the lexically specified I in N_2 is licensed by N_1 containing I, which is the harmonic domain head. Since there is no U in N_1 , U in N_2 is not licensed, and U in N_2 is delinked. In (13 b), the lexically specified U in N_2 is licensed by N_1 , but I is not. In (13 c), the lexically specified I and U in N_2 are both licensed by N_1 .

Denwood (1997 a) represents disharmonic words differently from harmonic words. The difference is that in harmonic words like *inek* ‘cow’, a harmonically dependent nucleus N_2 dominates a lexically specified (A.I), whose I element needs licensing to be interpreted, and in disharmonic words like *kitap* ‘book’, N_2 dominates only (A). Consider the following illustrations:

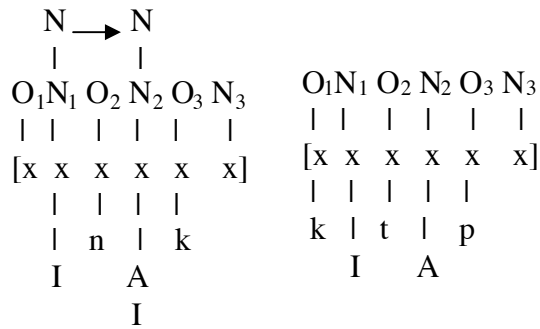
(14) *inek* ‘cow’b. *kitab* ‘book’

In (14 a), the A in N₂ occupies a dependent nucleus which is subject to constraints on licensing, whereas, the A in N₂ in *kitab* is independent (unconstrained). N₁ is the harmonic domain head in (14 a), which licenses I in N₂. However, N₂ in (14 b) is harmonically independent, and its content does not require licensing. In fact both N₁ and N₂ are harmonic domain heads, but two different kinds of harmony, one with I and one without I.

In Denwood (1997 a), the account of the difference between silent and non-silent final empty nuclei is also included. The difference between *kar* ‘snow’ and *kari* ‘wife’ is captured in her analysis. Consider the following illustrations:

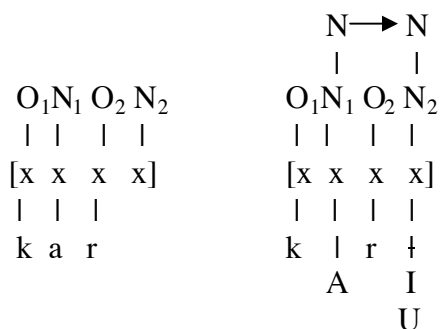
(15) a. *kar* ‘snow’b. *kari* ‘wife’

In (15 a), N₂ is a truly empty nucleus which is parametrically p-licensed since it is domain final. The reason why we hear ɿ in N₂ in (15 b) is that it has lexical I and U,

which are not phonetically interpreted since harmonic domain head N_1 does not contain I or U, therefore, she claimed that the phonological ECP cannot apply to N_2 . Note that ι does not contain any interpreted elements in its composition.

In the harmonic words above, nuclei are adjacent in the nuclear projection. However, harmony in Turkish is not only a phenomenon for adjacent nuclei, but it is also a long distance phenomenon. Let us look at a harmonic word with multiple suffixes to better understand how harmony works in GP:

(16) *göz-ümüz-ü* ‘eye+3rd.Pl.+Acc.’

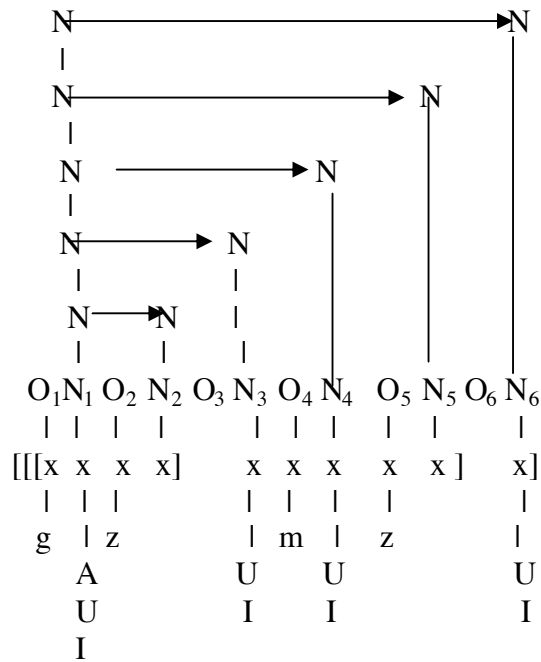

As can be seen in (16), the harmonic domain head N_1 can license all the nuclear positions (which have lexical I and U in them) to be interpreted with these elements. In GP, harmony does not take place between any two nuclei, let us say, N_4 and N_6 , but the content of dependent nuclei is licensed to be interpreted by the harmonic

domain head (N_1 in this case). Note that square brackets around skeletal points show the morphological domain.⁷⁹

In this analysis, N_1 in borrowed words with word-initial consonant clusters in their origin language is claimed to be occupied by I and U, which need a license to be interpreted in Dialect A in order to explain why the empty nucleus is not p-licensed as it is in Dialect B. In the word-final phenomenon, “unexpected” vowel harmony pattern or “disharmony” in the suffixes can be accounted for by the role stem-final palatalized consonants play, which is mentioned neither in Charette & Göksel (1996, 1998) nor in Denwood (1997 a) (Although disharmony in stems is discussed in her study). In this study, Denwood’s (1997 a) account is extended to cover cases of I-licensing domain triggered by the special relationship between a nucleus and the onset it licenses to contain a palatalised consonant.

5.3. Palatalized consonants

In this study, it is claimed that “palatalized” consonants play an important role in word-initial and word-final phenomena in Turkish. “Palatalization” is defined in this study as a lexical property of consonants having a shared I-operator in their elemental composition. In Turkish, all palatalized consonants are claimed to have the same composition, that is, they share the I-operator with the following nucleus, and thus they are different from true palatals which contain an I-head.

In this study, the sharing condition in Turkish is formally defined as “onsets licensed by a nucleus dominating I-operator must share the same I element with their

⁷⁹ The harmonic domains in [[geli][yorduk]] ‘come+Cont.+Past+3rdPl.’ are clearly independent. There are two domain heads in this word: N_1 is I-harmonic domain head, and N_3 is U-harmonic domain head. Since there is not only one domain, it is not a problematic case.

nucleus”. In other words, whenever I-operator is in the onset, I must be in the nucleus that licenses it, and whenever I-operator is in the nucleus, I must also be in the onset it licenses. It needs to be pointed out that this is an inter-dependent relationship. That is, the claim here is that the I element is shared between an onset and a nucleus rather than occupying one of them exclusively. How the sharing condition works in Turkish in order to account for the word-initial and word-final phenomena will be represented and discussed throughout this section.

When a word-final palatalized consonant shares I with the domain-final empty nucleus, that nucleus is called a “pseudo-empty nucleus”, which will be explained in section 5.3.1 below. Note that the sharing condition and “the pseudo-empty categories” might have some language specific characteristics, and might apply differently in different languages, which will be discussed by giving data from French (Haworth, 1994; Charette, 1998), Polish (Kaye, 1991; Gussmann and Kaye, 1993) and Khalkha Mongolian (Denwood, 1997 a).

Before we start discussing the sharing condition in Turkish in more detail, let us consider the previous work done on sharing. Kaye (1991) argues that in Polish it is impossible to claim that I is either in the onset or in the nucleus, that is, it is not possible to say which is affecting which. That is why, he represents the element I as “shared” between the onset and the nucleus, and not exclusive to one of them. According to Kaye’s notion of sharing, there is no derivation, no ‘process’, just a structural constraint on certain onsets and nuclei. Examples like *pies* ‘dog’- *psa* ‘dog+Gen.’ show us how sharing works in Polish, as illustrated below:

(17) a. *pies* ‘dog’ b. *psa* ‘dog+Gen.’

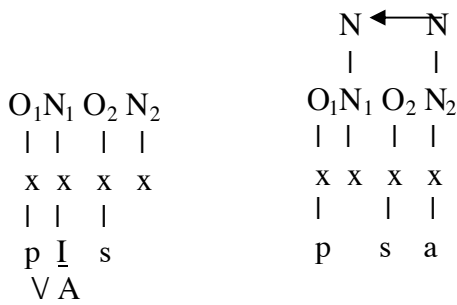

In (17 a), *pies* ‘dog’, the I and A elements are fused. O₁ and N₁ share an I element as a head in the nucleus and as an operator in the onset, and thus O₁ is palatalized. In (17 b), N₁ is properly governed by N₂, and thus remains silent. When N₁ is p-licensed, O₁ is not palatalized because according to Kaye, if there is no I-operator in the onset, then there is no I-head in the nucleus. That is why, it is impossible to say the nucleus palatalizes the onset, or the onset affects the nucleus.

Gussmann and Kaye (1993) propose sharing to explain why a palatalized consonant cannot precede a p-licensed nucleus in Polish, as shown in (17) above. It follows from this that it is also not possible to find a palatalized consonant word-finally.

Denwood (1997 b) extends and adapts Kaye’s sharing analysis to palatalized consonants in Khalkha Mongolian with the difference that palatalized consonants can precede a p-licensed N, as will be explained below. According to Denwood, there are two types of vowels which follow palatalized consonants in Khalkha Mongolian depending on whether or not there is additional content in the nucleus besides the shared I element. She discusses the first kind where the I element is not fused with A. For example, in [x^jam] ‘sausage’, the I element is not

fused.⁸⁰

(18) [x^jam] ‘sausage’

$$\begin{array}{cccc}
 O_1 N_1 & O_2 & N_2 & \\
 | & | & | & | \\
 [x & x & x & x] \\
 | & \wedge & | & \\
 H & / \setminus & m & \\
 | & \underline{I} & A & \\
 | & & & \\
 \wedge & & &
 \end{array}$$

In (18), the I element is doubly linked to the headless expression in the onset and as a head in the nucleus. (A) also occupies the nucleus besides the doubly linked (I).⁸¹ (A) determines the harmony in this case because it is uniquely associated with the nucleus, e.g. [x^jama:] ‘sausage+Poss.’ but not *[x^jame:].

We observe a very similar case to Khalkha Mongolian in Turkish. In this study, it is claimed that Turkish consonants which do not contain an I-head in their composition (true palatal consonants) are palatalized through sharing an I-operator with their nuclei. I in these nuclei might be fused or unfused. In the examples of palatalized consonants in words like [k^j]ar ‘profit’, [g^j]avur ‘pagan’, [f^j]a ‘musical note’, im[k^j]an ‘opportunity’, ha[f^j]a ‘still’ and rüz[g^j]ar ‘wind’, it is claimed here that these onsets containing palatalized consonants are licensed by the nuclei containing an unfused I element. Consider the illustration of such a word:

⁸⁰ In that analysis, I in the nucleus is a head, as it is the case in Polish too. In these two languages, the I-operator is not involved in sharing.

⁸¹ Denwood proposes ‘fronting’ of *a* in [x^jam] ‘sausage’ in Khalkha Mongolian by spreading an I operator into the nucleus to fuse with (A).

(19) [k^j]ar ‘profit’

O ₁ N ₁	O ₂	N ₂
[x	x	x
	∧	
H	/	A
<u>ɿ</u>	I	A
/		

In (19), [k^j] is palatalized since the I element is shared between O₁ and N₁. N₁ is not interpreted as *e* since I and A do not fuse, but it might be heard as fronted since it shares I with its onset.⁸² In Turkish, there is a minimal pair consisting of [k^j]ar ‘profit’ and *kar* ‘snow’, the former has a shared I between O₁ and N₁, and the latter does not have I. Note that in words like [k^j]ar ‘profit’, N₁ is the harmonic domain head. The type of harmony is determined by A rather than by the shared I, e.g. [k^j]ar-da ‘profit+Loc.’, but not *[k^j]ar-de.

In [k^j]ere⁸³ ‘times’, however, N₁ is different from N₁ in [k^j]ar ‘profit’:

(20) [k^j]ere ‘times’

O ₁ N ₁	O ₂	N ₂
[x	x	x
H	A	A
<u>ɿ</u>	I	\
/		I

⁸²Also, Selen (1979), Ergenç (1989 and 1995) discuss Turkish consonants and vowels by looking at sonograph analyses, but there is no mention of palatalized consonants or “fronted” vowels.

⁸³ Phonetic representation of palatalized consonants is given only when it is relevant to the discussion. Note that that all the consonants sharing an I element with their nuclei are claimed to be palatalized in Turkish. The “phonetic” degree of palatalization might vary depending on the type of consonant.

In (20), N_1 shares the I element with O_1 which is fused with A.⁸⁴ So, N_1 is the harmonic domain head of the I-domain. Note that O_2 also shares the I element with N_2 , which is a dependent nucleus which has an I element licensed by N_1 . According to the reduction harmony analysis N_2 contains both an A element, which needs no harmonic licensing, and an I element which needs licensing by the domain head. The difference between $[k^j]ar$ and $[k^j]ere$ is that (I) and (A) are two separate expressions associated with N_1 in $[k^j]ar$. Since they are not fused, the content of the nucleus which is not shared with the onset (A in this case) determines the harmony of the following suffix(es) as a harmonic domain head. However, in $[k^j]ere$, (I) and (A) are fused, and N_1 is the I-harmonic domain head.

When there is an I-harmonic domain head, all the onsets are in the I-licensing domain in addition to the dependent nuclei. Since in GP, all onsets are licensed by their nuclei, and since in the illustration (21), all nuclei are licensed by I-harmony domain head N_1 , onsets which do not contain true palatals are palatalized. Let us look at the following illustration to better understand the explanations:

⁸⁴ The question why I fuses in some cases but not others could be ideally answered by licensing constraints, but not within the present analysis.

(21) *git-tik-ten* ‘go+Nom.+Abl.’⁸⁵

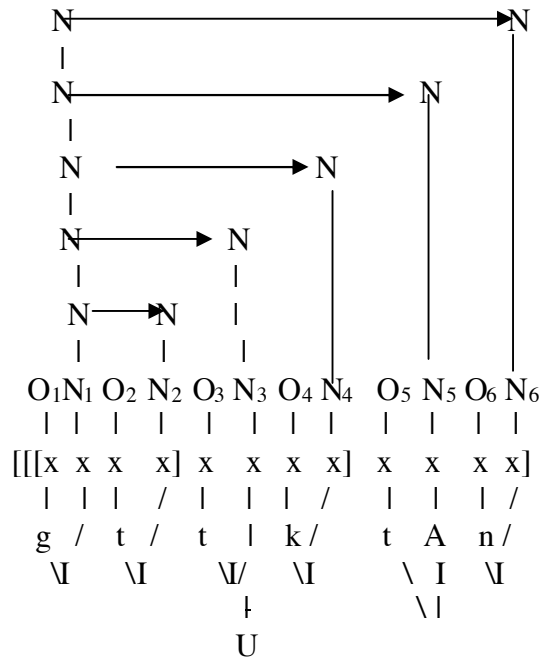

In (21), N_1 is the I-harmonic domain head and licenses all the dependent nuclei in its harmonic domain. Since all these nuclei license their onsets, all the onsets are in the I-harmonic domain too, which is the automatic consequence of a sharing condition. N_1 licenses not only I in N_3 and N_5 , which are lexically occupied by I, but also N_2 , N_4 and N_6 , which are “pseudo-empty final silent nuclei” which will be discussed below.

5.3.1 Pseudo-empty nucleus analysis

After having discussed sharing in some length, it is time to discuss “pseudo empty nucleus”, which follows naturally from sharing.

Haworth (1994) claimed the notion of pseudo-empty categories for the very first time by analyzing French. She defines a “pseudo-empty category” as the

⁸⁵ For practical reasons, the elemental composition of consonants is not represented completely, but all

otherwise empty category where the segmental material associated with a position is not exclusive to it, but shared between two positions. As far as the concept of pseudo-empty categories is involved, there seem to be two kinds of languages, (i) those which do not allow pseudo-empty categories, like Polish; therefore, there are no palatalized consonants before a p-licensed nucleus, (ii) languages which allow pseudo-empty categories, like Khalkha Mongolian. In this case, when, for example, the nucleus contains nothing but the shared element it can be p-licensed, therefore, it is possible for a palatalized consonant to precede a silent nucleus in this kind of language.

In the notion of pseudo-empty categories, the shared element does not have to be interpreted in both positions. That is, it can be either interpreted in the onset or nucleus. Also since pseudo-empty categories are subject to the conditions of the ECP like parametrical p-licensing, proper government and inter-onset government, the shared element does not necessarily need to be interpreted in both positions.

Let us look at the representation of pseudo-empty categories in French by Haworth (1994). Consider the illustration of Continental French [l^je] ‘tied’:

(22) [l^je] ‘tied’

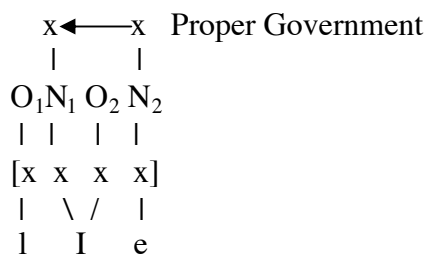

the consonants have I in their compositions eg. g (I.2).

In (22), the I element is shared between N_1 and O_2 , but it is only interpreted in O_2 since N_1 is properly governed by N_2 . Note that in French, the I element is not part of the onset containing [l], that is, the French analysis is not about palatalized consonants. In (22) both N_1 and O_2 are pseudo-empty, but it is N_1 that is p-licensed. As a result of p-licensing only O_2 is interpreted, and the word is interpreted as [lⁱe] not as *[lie] or *[lije]. The aims of this illustration are to discuss how pseudo-empty categories are first suggested and to show that pseudo-empty categories are subject to the ECP.

Charette (1998) adopts Haworth's (1994) pseudo-empty category analysis in order to account for different dialects of French. She considers cases where an empty nucleus follows a p-licensed pseudo-empty nucleus. She claims that proper government of an empty nucleus and proper government of a pseudo empty nucleus are different.⁸⁶

According to Kaye (1991) if the shared I is not interpreted in the nucleus, it cannot be interpreted in the preceding onset. Denwood (1997 b) proposes a sharing analysis for Khalkha Mongolian, which is different from Kaye's 'sharing' proposal in that Khalkha Mongolian has palatalized consonants before a p-licensed nucleus, whereas Polish does not. When sharing occurs word-finally, the nucleus which is "pseudo-empty" (it contains only a doubly linked I) is parametrically p-licensed, therefore, the I is interpreted only in the onset.

Denwood (1997 b) discusses I-sharing in Khalkha Mongolian to account for I-umlaut.⁸⁷ She states I-umlaut in Khalkha Mongolian as evidence that I is linked to

⁸⁶ She proposes "government licensing" in order to explain the difference, but in this study, this tool is not utilized. (For detailed discussion, see Charette, 1998)

⁸⁷ Denwood (1997 b) discusses umlaut as I-licensing in Khalkha Mongolian. She states that umlaut is the leftward spreading of the I element through a licensing relationship between nuclei in Khalkha Mongolian, and it is generally used for words in which vowel harmony is not active. I-licensing in Khalkha Mongolian is defined by Denwood (1997 b) as "A nucleus which dominates an I-head which

the uninterpreted nucleus since umlaut has to take place through a relationship between two nuclei, which could also be a long distance relationship. Let us consider a concrete example in Khalkha Mongolian:

(23) a. [æɫⁱim] ‘apple’

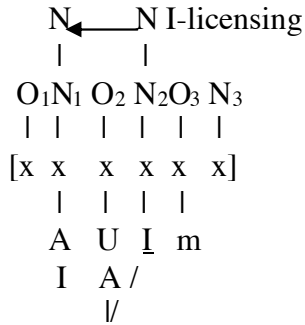

b. [æɫⁱma:] ‘apple+Poss.’

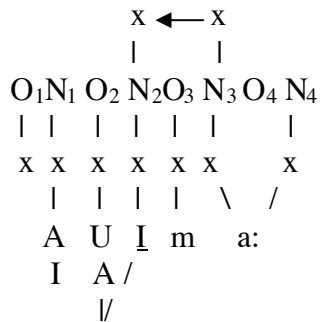

In (23 a), I is in the composition of O₂ and N₂. N₂ as a pseudo-empty nucleus I-licenses N₁. In (23 b), N₂, which contains only a shared I-element is p-licensed by N₃. Note that the p-licensed nucleus N₂ is still an I-licensor of N₁.

Denwood (1997 b) defines the Khalkha Mongolian sharing condition as: whenever an onset contains an I-operator, then the nucleus contains I-head, and whenever a nucleus contains I-head, the onset has an I-operator. Since Khalkha

is doubly-linked to the preceding onset is an I-licensor, licensing I to spread as an operator to the preceding nucleus.” I-licensing is not represented below, because it does not seem to be relevant to Turkish. Note that in Khalkha Mongolian harmony is not analyzed as I-licensing.

Mongolian has word-final palatalized consonants, this also involves the pseudo-empty concept, unlike Polish. For a pseudo-empty category to be p-licensed, it should not have any other content than I. When a position, i.e. the second onset in (24), has additional content, it is not a pseudo-empty category and must be interpreted. The domain final nucleus is parametrically p-licensed although it is occupied by the shared I element [mœrʲ] ‘horse’:

(24) [mœrʲ] ‘horse’

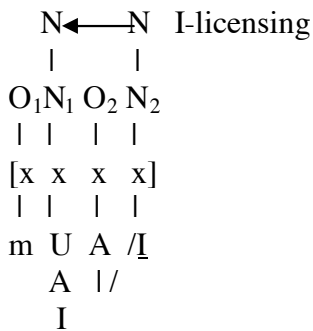

In (24), an onset dominating a palatalized consonant shares the I element with the nucleus licensing it. N₂ in this case is not empty, but pseudo-empty since it shares a single I element with the preceding onset. N₂, which is a p-licensed nucleus, takes part in I-licensing as in (23 b), with the difference that the pseudo-empty nucleus N₂ in (24) is parametrically p-licensed, whereas the one in (23 b) is p-licensed through proper government.

5.3.2. Word-initial phenomenon

In this study, how N₁ is vocalized in borrowed words with word-initial consonant clusters is described as the “word-initial phenomenon” considering the

pronunciation of Dialect A speakers. It is claimed here that Turkish does not have branching onsets in Dialect A. Since a branching onset is one onset with two branches, there cannot be a vowel between two branches. In this study, three kinds of empty nuclei are recognized: i. truly empty nuclei, which can be p-licensed, ii. pseudo-empty nuclei, which can also be p-licensed, and iii. the ones which are filled with uninterpreted elements, which cannot be p-licensed according to the reduction harmony analysis (Denwood 1997 a).

It is claimed that N_1 is not p-licensed in Dialect A since it contains lexical I and U. I is only interpreted when shared with O_1 . U needs to be licensed by N_2 U-licensing, which will be discussed in section 5.4. The direction of I-licensing is claimed to be left to right by mainly looking at certain “disharmonic” cases of word-initial phenomenon. When we consider harmonic words like *t[i]ren* ‘train’ as provided below, they do not give us any evidence about directionality.

(25) *t[i]ren* ‘train’

O_1	N_1	O_2	N_2	O_3	N_3
[x	x	x	x	x	x]
					/
t				n	I
\	I	A	A	/	
	†		I		
	U		/		

In (25), I is shared between O_1 and N_1 . Also, I in N_2 is shared by O_2 , and O_3 shares the I element with N_3 , which is a final silent pseudo-empty nucleus. In this case, it is not possible to test if N_2 is licensing N_1 , which would be a case of I-umlaut (leftward I-licensing), or N_1 is licensing N_2 , a case of regular rightward I-licensing, or N_1 is interpreted as [i] as a result of I-sharing with O_1 . It is lexically given that N_1 shares I

with O_1 in $t[i]ren$ but not in $t[i]raş$ ‘shave’. In other words, even if direction were right-left, which would mean that I in N_1 is licensed by I in N_2 which is shared by the palatalized O_2 , then the I-sharing condition would also hold between O_1 and N_1 . Since both O_1 and O_2 end up palatalized, it is not possible to know which way it was. It seems that in Turkish, examples like $t[i]ren$ do not really show the direction of I-licensing.

In Turkish, there are also words like $p[i^j]an$ ‘plan’ and $p[i^j]ak$ ‘record’, which do not provide us with evidence about directionality although they are “disharmonic”. In such words, N_1 is also interpreted as [i]. The difference between the words like (25) and these words is that O_2 in these words is palatalized through the sharing condition where I is shared with N_2 containing unfused I and A, which is why, a new harmonic domain starts here, e.g. $p[i^j]ak-lar$ ‘record+Pl.’. Consider the following illustration:

(26) $p[i^j]ak$ ‘record’

O_1N_1	O_2	N_2O_3	N_3
[x	x	x	x
			x
		^	
p /	/	A	k
\I	A	I	
†	U /		
U	/		

In (26), O_1 and N_1 share an I element, and O_2 and N_2 share an I element. It is not possible to test if N_1 is licensed by N_2 , or it is licensed by sharing I with O_1 . That is to say, even if I in N_1 were licensed by N_2 , O_1 would also be palatalized through the sharing condition, which makes it impossible to test for direction. Therefore, these words cannot be used as evidence for directionality either.

The words which do provide evidence for directionality are the ones in which there is an I element in N₂, but no I in N₁, like *k[i]riz* ‘crisis’, *g[i]rip* ‘flue’ etc. In the illustration (27) below, N₁ is pronounced as [i], although N₂ shares an I element with O₂.

(27) *k[i]riz* ‘crisis’

O ₁ N ₁	O ₂	N ₂ O ₃	N ₃
[x x	x x	x x	x]
			/
k	ɫ	l	z I
	I	A	l /
	U	\	/

The fact that N₁ in (27) is not interpreted with I although N₂ has I in its composition is claimed to be evidence that there is no head-final I-licensing in Turkish. Note that O₃ also shares I with the pseudo-empty N₃.

There are also some words in which N₂ contains I fused with another element:

(28) *k[i]rem* ‘creme’

O ₁ N ₁	O ₂	N ₂ O ₃	N ₃
[x x	x x	x x	x]
			/
k	ɫ	l	m I
	I	A	A /
	U	\	I

(In 28), N₂ has a fused content and I is the harmonic domain head, which results in O₃ and N₃ sharing an I element. N₁ is still interpreted as [i], since N₂ cannot I-license leftwards. Consider the following illustration in which N₁ is interpreted in the same way, but it is not a “disharmonic” word.

(29) $k[i^j]an$ ‘clan’

O ₁	N ₁	O ₂	N ₂	O ₃	N ₃
[x	x	x	x	x	x]
			\		
k	t	l	l	A	n
	I	A			
	U	U\	/		
		I			

In (29), there is no I-sharing between O₁ and N₁, but O₂ and N₂ share an I element which is not fused with A. Although O₂ is palatalized, it has not effect on harmonic domain.

In Turkish we have additional evidence from the distribution of [i] that I-licensing is head-initial. It is not possible to have [i] in the second nucleus of a word when N₁ contains I, e.g. **kilim*. That is to say, since I-licensing is left-to-right, such examples do not exist, but we find examples like *k[i]riz* ‘crisis’, which show that right-to-left licensing is not possible. Also, there is no [i] in the suffixes where the last nucleus has I, e.g. **kilim-i*. In other words, although we find I in the suffixes when the final nucleus does not have I in it, we cannot find [i] when we have I in the last nucleus of the stem. This is another piece of evidence that I-licensing is right-to-left, with no exceptions. Although there is no evidence for direction in *t[i]ren* ‘train’ and *p[il^j]ak* ‘record’, by claiming head-initial I-licensing throughout, there are no exceptions in the word-initial phenomenon, .

5.3.3. Word-final phenomenon

In section 5.3.1, we discussed pseudo-empty nucleus analysis in French and Khalkha Mongolian. Section 5.3.2 dealt with the word-initial phenomenon where pseudo-empty nuclei were mentioned, but did not play a role in our analysis. In this section, we are going to discuss the word-final phenomenon, which is about the interaction between word-final palatalized consonants and pseudo-empty nucleus, which in turn determines suffix harmony.

Similar to the Khalkha Mongolian word [mœrʲ] ‘horse’, in Turkish, there are palatalized consonants which share an I element with the final silent nucleus, which is pseudo-empty, e.g. *ha*[ʲ] ‘condition’⁸⁸. As mentioned earlier, pseudo-empty nuclei can be p-licensed. Let us consider more examples of such cases:

- (30) *ihla*[ʲ]-*i* ‘violation’ *idra*[kʲ]-*i* ‘realization’ *beraa*[tʲ]-*i* ‘acquittal’
sua[ʲ]-*i* ‘question’ *hila*[ʲ]-*i* ‘crescent’ *dikka*[tʲ]-*i* ‘attention’

All the words in (30) include the accusative suffix, which is interpreted as [i]. If vowel harmony were the sole source of the non-final vowel, then *sual-i* would be interpreted as **sual-i*. By looking at the words in (30), it is claimed in this study that pseudo-empty nuclei following word-final palatalized consonants are the new I-harmonic domain head since the I element in palatalized consonants is shared with

⁸⁸ In Khalkha Mongolian, harmony is not affected by the word-final palatalized consonant, which could be partly because “harmony” is not I-harmony, but there is umlaut in this context in KM i.e. [mœrʲ] ‘horse’.

the following “pseudo empty nucleus” (Haworth, 1994; Denwood, 1997 b; Charette, 1998).

Support for using the “pseudo-empty nucleus” analysis for Turkish comes from Denwood’s (1997 b) analysis of Khalkha Mongolian. The p-licensed nucleus in words like [æɪ̯ma:] ‘apple+Poss.’ as illustrated in (23 b) and [mœɪ̯] ‘horse’ as illustrated in (24) still has an inter-nuclear relationship. That is to say, N₂ I-licenses N₁ although it is p-licensed, as part of Khalkha Mongolian I-umlaut. Our analysis of the word-final phenomenon in Turkish follows from Denwood’s Khalkha Mongolian I-umlaut analysis in that a p-licensed pseudo-empty nucleus can license other nuclei. In Khalkha Mongolian, it is the preceding nucleus which is I-licensed as a condition of I-umlaut, in Turkish, it is dependent nuclei in the suffix(es) which are I-licensed.

Remember that Denwood’s (1997 a) view of harmony, which is adopted in this dissertation, is based on the licensing of the nuclei containing I and U, which need a license from the same elements in the initial nuclei to be interpreted since they are dependent nuclei. Let us look at the following illustration to see how this analysis works:

(31) *saa*[t̪]-i ‘watch+Acc.’

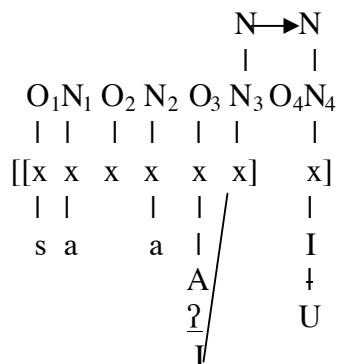

In (31), N_3 is a pseudo empty nucleus which shares the I element with O_2 . Note that pseudo-empty nuclei can be p-licensed, and in this example, N_3 is parametrically p-licensed since it is domain-final. As the new I-harmonic domain head, N_3 can license N_4 .⁸⁹ N_4 would be interpreted as [i], if O_3 were not palatalized, as in *sanat-i* ‘art+Acc.’. Note that U in N_4 can only be licensed by the U-licensing domain head, but since there is no U in the nuclei of the stem, U in N_4 does not have a license and cannot be interpreted (see section 5.4 for the detailed discussion of U-licensing).

One might wonder why a silent nucleus has been claimed to be a harmonic domain head in this context. First of all in GP, onsets cannot be the harmonic inter-nuclear domain head, since nuclei license onsets and not vice versa. Especially, since I-harmony in Turkish is not a short distance phenomenon simply a local relationship between an onset and its nucleus, that is, it does not take place locally, but a long distance phenomenon between all the nuclei of the harmonic domain (as represented in (32)). In GP, harmony, as a supra-segmental condition, takes place between projected nuclei: the I-harmonic domain head and the dependent nuclei. Secondly, as represented in (32) below, N_3 cannot be claimed to be the new harmonic domain head since it is a dependent nucleus, whose content need to be licensed in order to be interpreted. Since it would be illogical to propose that a governee should also be a governor in the same process, dependent nuclei cannot become independent in some contexts, or become a harmonic domain head. Thus, the only possibility is that the pseudo-empty nucleus acts like a new I-harmonic domain head.

⁸⁹ Sharing analysis makes the same predictions for vowel-zero alternating nuclei in 'exceptional' words like *vak[i]t* ‘time’ - *vakt-i* ‘time+Acc.’. I is shared between O_2 and N_2 , and when N_2 is p-licensed by N_3 as it is the case in *vakt-i*, N_2 is a silent pseudo-empty nucleus, which is the I-harmonic domain head licensing all the nuclei in the suffix(es). This is the same principle claimed for the word-final phenomenon in that a final silent pseudo-empty nucleus acts as the new I-harmonic domain head.

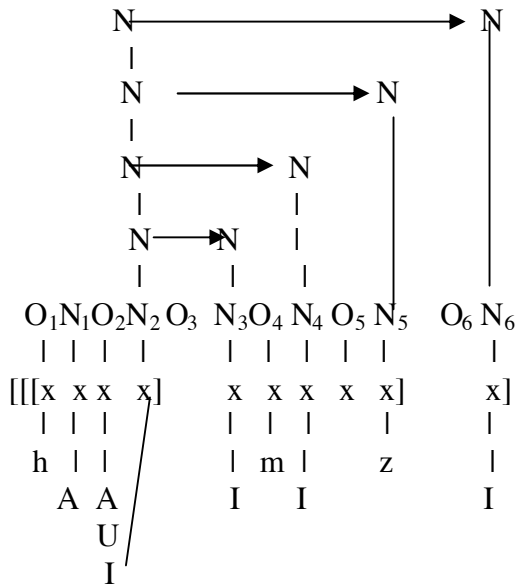
(32) *ha[F^h]-imiz-i* ‘condition+3rdPl.Poss+Acc.’

In (32), it can be seen that the I-harmonic domain head is N_2 , which is a pseudo empty nucleus as a result of I-sharing with O_2 . As a new I-harmonic domain head, N_2 licenses the I elements in the nuclei in the suffixes, which are all dependent on the harmonic head. Note that harmony in GP is not a chain relationship, that is, N_2 licensing N_3 , N_3 licensing N_4 etc., but it is a relationship between the harmonic domain head and all the other nuclei in its domain.

In (31) and (32) above, the palatalized consonants are stem-final, and their interaction with the pseudo-empty nuclei, in the sense of I-sharing, determines the suffix vowel harmony. There are also some cases where both consonants in the word-final clusters are palatalized. There are two possibilities to analyze the word-final phenomenon involving word-final consonant clusters. The new domain head is either N_2 as represented in (33 a), or N_3 as represented in (33 b). It is impossible to know which one is responsible for I-licensing since there is no way to test it, as in the discussion about *t[i]ren* ‘train’.

However, U does not alternate unless N_2 is in the U-harmonic domain as in *küf[ü]r* ‘swear’ *küfr-ü* ‘swear+Acc.’

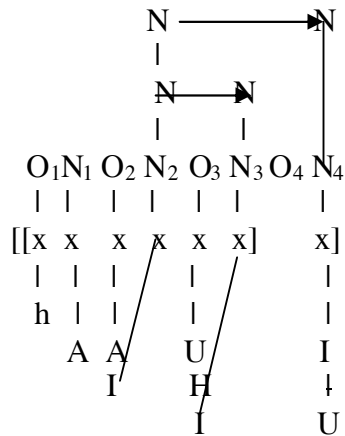
(33) a. *ha[r^{ij}]-i* ‘letter+Acc.’

b.

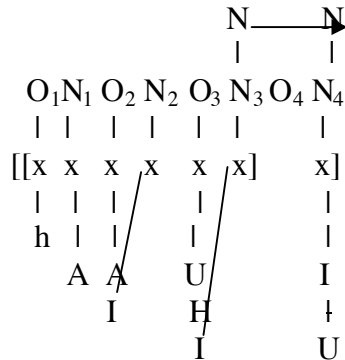

In (33 a), the pseudo empty nucleus N₂ shares the I element with the preceding onset, and thus becomes the I-harmonic domain head. N₄ is licensed by N₂, and interpreted as I. In (33 b), however, the I-harmonic domain head is represented as N₃. Note that both nuclei in question are p-licensed, N₂ by inter-onset government, and N₃ parametrically p-licensed. Inter-onset government between O₂ and O₃ is suggested in Chapter 4 for word-final consonant clusters, which results in non-interpretation of N₂.⁹⁰ As far as harmony is concerned, it does not seem to be important which one of the two pseudo-empty nuclei is the new I-harmonic domain head.

⁹⁰ Inter-onset government is not illustrated in (33) between O₃ and O₂ in order to avoid confusion between I-licensing and inter-onset government.

5.4. U-licensing

Although the focus of this chapter is the interactions between palatalized consonants and vowels, in addition to the I element, the U element is also licensed in the dependent nuclei in word-initial and word-final phenomena. It is claimed that U-licensing is quite different from I-licensing in terms of directionality and constraints.

5.4.1. Word-initial phenomenon

In a discussion of the word-initial phenomenon, I is not the only element in N_1 , there is also U in some contexts (as represented in (1) in the beginning of this chapter). In order to account for the source and direction of U in N_1 , we are going to consider some examples of the word initial phenomenon involving U.

Consider the following example where O_1 and N_2 contain the U element in its composition:

(34) *b[u]roʃ* ‘brooch’

O_1N_1	O_2	N_2O_3	N_3
[x	x	x	x x x]
U			ʃ
?	U	A	A
	†	U	
	I		

In (34), since both O_1 and N_2 contain U in their composition, they do not provide any evidence about the source or direction of U. There are many words which start with a labial stop like *b[u]rokoli* ‘broccoli’, *p[u]rotesto* ‘protest’, *p[u]rofesör* ‘professor’.⁹¹ There are also labial fricatives as the first onset, and N_1 is pronounced with U. In the following example, O_2 also contains U in its composition.

(35) *f[ü]lorit* ‘fluoride’⁹²

O_1N_1	O_2	N_2O_3	N_3	O_4	N_4
[x	x	x	x	x	x]
H		/\	r		t/
U	U	A	I	A	\
\	I	U/	U		
		/			

In (35), N_1 is interpreted with both U and I elements. I is shared between O_1 and N_1 , and O_2 shares an unfused I element with N_2 . Since I is not fused with A and U, N_2 is not interpreted as *ö*. However, the source of U could be O_1 , O_2 or N_2 . Therefore, considering such examples will not help us determine the source of the U element in N_1 .

There are some words in which there is only one possible source of U, which will give us evidence about directionality. Let us now consider a word in which N_1 is interpreted as [u]:

⁹¹ These words were tested with 40 subjects in a similar way to the one explained in section 3.3.1.4. N_1 in all these words was pronounced with the U element. However, in Dialect A, there might be a group of speakers who prefer [i] instead of *u* in their pronunciation of words having *o* in N_2 . For such a sub-dialect, it is suggested that when U is in a complex expression, (*o*, which consists of two elements: (U.A) is a complex expression) U in N_2 does not license U in N_1 . The exact quality of N_1 in such cases should be tested in Phonetics labs, which is the scope of further research.

⁹² Since this is a loan word, there are many harmonic domains, some of which overlap. It is not the purpose of this thesis to analyze all kinds of word-internal disharmony.

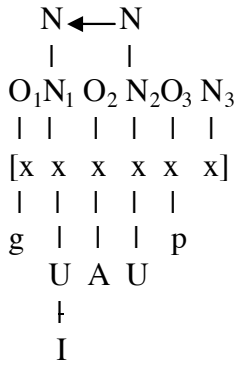
(36) *g[u]rup* ‘group’

In (36), U in N₁ can only be licensed by N₂ since other constituents do not have U in their composition. There are other words where U can only come from N₂ as in *k[u]rokan* ‘crunch’, *T[u]ruva* ‘Troy’, and *k[u]rom* ‘chromium’.

However, there are also words involving *s* as the first consonant of the word, in which N₁ is not interpreted as U although N₂ contains U.⁹³

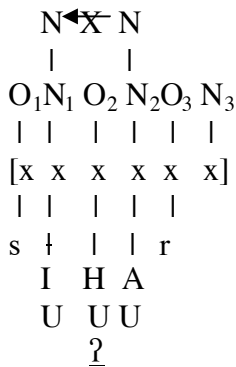
(37) *s[i]por* ‘sport’

⁹³There are some words starting with *s+C* in their source language, but these start with *i* or *ɪ* in Turkish. However, this is not a productive process in Turkish since there are only a restricted number of words in this category, e.g. *spanak* ‘spinach’, *istasyon* ‘station’, *iskelet* ‘skeleton’. Therefore, it is possible to analyze such examples in Standard Turkish as lexicalized. However, in the Trabzon Dialect of Turkish, this seems to be a more productive tool used with borrowed words even when they do not start with consonant clusters. For example, in words like *irecep* ‘proper name’, *iramazan* ‘proper name’, *ilimon* ‘lemon’, *ilazım* ‘necessity’ (Aksan et. al. (1978) also mention *urum* ‘Greek’ and *ürüzgar* ‘wind’), there is I in the nuclei of the added ON pair because *r* and *l* are palatalized. Historically, Turkish words did not begin with *r* or *l*. The reason why words starting with *r* and *l* go through this process might be related to the need to mark these words as borrowed in this dialect. Another reason might be that these two consonants do not make good initial consonants as a result of constraints on word-initial onsets in that particular dialect.

In (37), N_1 is interpreted as [i] since I is not shared between O_1 and N_1 , and U is not licensed by N_2 .

In the light of examples given above, in this study, leftward U-licensing is suggested for Turkish following Denwood's (1997 b) right-to-left I-licensing condition for Khalkha Mongolian which says "A nucleus which dominates an I-head which is doubly-linked to the preceding onset is an I-licensor, licensing I to spread as an operator to the preceding nucleus." Leftward U-licensing in Turkish is defined formally in this study as the following:

(38) Leftward U-licensing: A nucleus dominating U, which licenses a headless onset, licenses U in N_1 .

According to leftward U-licensing, N_2 as U-harmonic domain head licenses U in N_1 unless O_2 is headed. When O_2 dominates a headed expression like stops, N_2 dominating U cannot license U in N_1 .⁹⁴ For example in *s[i]por* 'sport', the U element in N_2 does not license U in N_1 since *p* is headed, thus N_1 is realized as [ɪ], which is represented in (37) above.

Another piece of evidence for leftward U-licensing could be that U in N_1 in the word-initial phenomenon is not possible when N_2 does not contain U. There are no words like **f[ü]ren* (*f[i]ren* 'brake') or **p[u]lak* (*p[il]ak* 'record') in Turkish. In both of these examples, O_1 contains U, and the latter even contains U in O_2 , but N_1 is not pronounced with U, which proves that U-licensing, as an inter-nuclear relationship between N_2 and N_1 , takes place leftwards.

⁹⁴ For speakers who pronounce *S[u]putnik* 'Sputnik' and *s[u]tudyö* 'studio' (Taylan, personal communication), there is no constraint on U-umlaut, which might a parametric difference between dialects.

In this dissertation, the only element shared between an onset and a nucleus is the I element. In Turkish, there is not any relationship between a final labial or labialized consonant and the following suffix, unlike palatalized consonants. For example, *sap* ‘handle’ becomes *sap-ı* ‘handle + Acc.’ not *sap-u*, although *p* has U in it. U-licensing is a purely inter-nuclear phenomenon, and has no relationship with the composition of the final consonant, unlike the case in I-licensing, that is, word-final labial consonants never trigger U in the following suffix.

In the following example, how leftward U-licensing works is represented:

(39) *k[u]rom* ‘chromium’

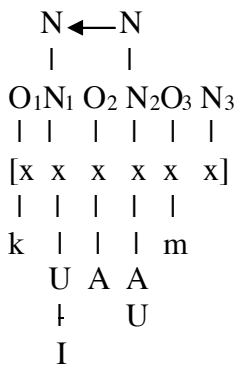

In (39), the U-harmonic domain head is N₂. Note that neither O₁ nor O₂ has U in their composition. Following the definition in (38), since O₂ is headless, U in N₂ can license U in N₁. I in N₁ is not licensed since it is not shared by O₁.

Words like *b[u]lüz* ‘blouse’ which could be accounted for neither in Yavaş (1980) nor Clements and Sezer in (1982) can be explained in this analysis.

(40) *b[u]lüz* ‘blouse’

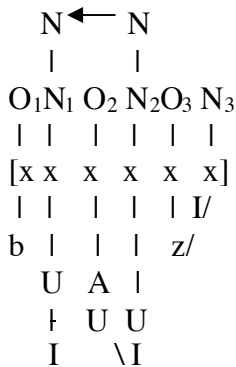

In (40), N₂, which has U in its composition, can license the U element in N₁, which is illustrated in the appropriate nuclear projection. It is proposed here that unless O₂ is headed, N₂ licenses U in N₁. N₁ does not contain the I element since in Turkish there is no leftward I-licensing, and O₁ does not share I because [b] is not palatalized. In (40), O₂ and N₂ share an I element, O₃ shares an I element with N₃, which is a final silent pseudo-empty nucleus.

Unlike I-licensing, U-licensing is claimed to be bi-directional. The U-harmonic domain head can license the dependent nuclei in both directions. We have talked about leftward licensing in this section, which is blocked by a headed onset; now let us consider the word-final phenomenon, where we observe rightward U-licensing.

5.4.2. Word-final phenomenon

In section 5.3.3, the word-final phenomenon is discussed only in relation to I-licensing. However, in Turkish, we also have rightward U-licensing. In Turkish I-harmonic domain heads can be different from U-harmonic domain heads. In the

word, represented in (41) and (42), has both I-licensing and U-licensing taking place. First I-licensing is represented in (41).

(41) *go*[ɟ]-*ümüz-ü* ‘goal+3rd.Pl.+Acc.’

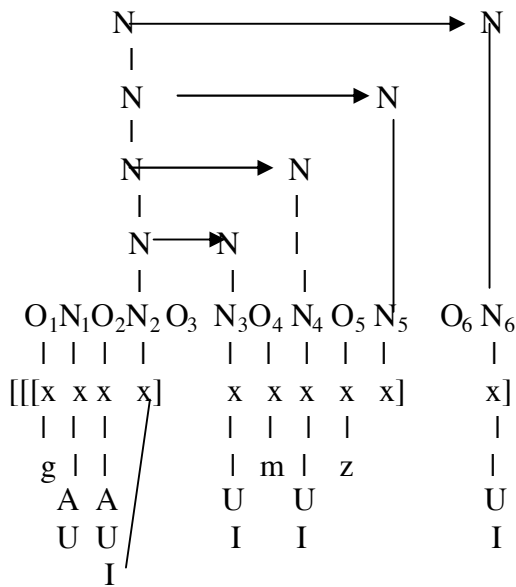

In (41), it can be seen that the I-harmonic domain head N_2 , which is a pseudo-empty nucleus, becomes I-harmonic domain head as a result of I-sharing with the stem-final palatalized consonant. N_2 licenses all the nuclei in its harmonic domain, as discussed in 5.3.3. Although both U-licensing and I-licensing take place simultaneously, U-licensing is represented separately below for clarity.

(42) *go*[^h]-*ümüz-ü* ‘goal+3rd.Pl.+Acc.’

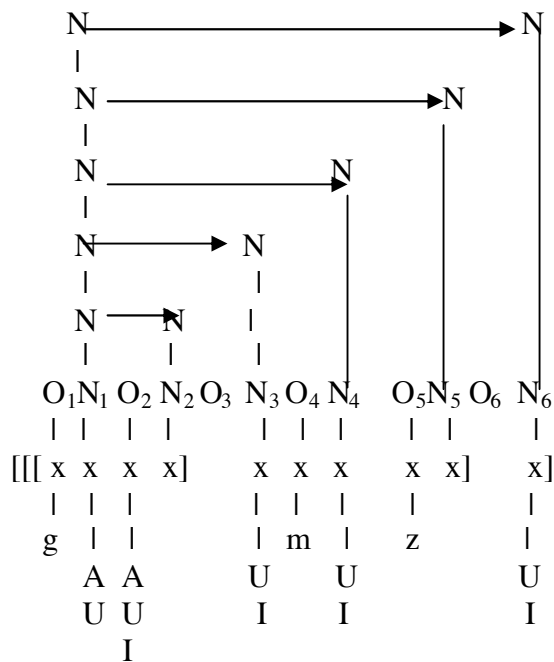

In (42), the U-harmonic domain head is N₁, and all the nuclei are licensed by N₁, and thus interpreted with U. Unlike leftward U-licensing, headed stops do not block rightward U-licensing.

5.5. Conclusion

In this chapter, interactions between palatalized consonants and vowels are discussed in word-initial and word-final positions. After presenting some of the previous studies in 5.1, in section 5.2 vowel harmony accounts of Charette & Göksel (1996, 1998) and Denwood (1997 a) are summarized. The discussions of licensing constraints suggested by Charette & Göksel (1996, 1998) show that their licensing constraints contradict the ones suggested in this study. As a result, Denwood's (1997

a) account is adopted since she represents Turkish vowels as headless expressions, which is parallel to the licensing constraints suggested in this study.

In section 5.3, palatalized consonants are claimed to share an I element with their nuclei. All the palatalized consonants have an I-operator in their composition, which is different from true palatals which have an I-head in their composition. I-licensing is claimed to be only left-to-right, so I-licensing does not play a role in the interpretation of N_1 . In order to account for the word-final phenomenon, the pseudo empty nucleus analysis is used. The pseudo-empty nucleus following a palatalized consonant becomes the I-harmonic head by sharing I with the palatalized consonant.

In section 5.4, U-licensing is discussed for both word-initial and word-final phenomena. Unlike I-licensing, U-licensing is claimed to be bi-directional, i.e. taking place from the U-harmonic domain both leftwards and rightwards. Leftward U-licensing is defined in this study as “a nucleus dominating U, which licenses a headless onset, licenses U in N_1 ”. In this chapter, rightward U-licensing is also discussed in relation to the word-final phenomenon, where U-licensing takes place at the same time with I-licensing. Rightward U-licensing is not blocked by a headed consonant, which shows head-final relationships may be different from head-initial relationships as far as U is concerned’ In short, I-licensing and U-licensing are found to be quite different from each other in Turkish.

The summary of the behavior of the elements A, I and U in nuclei, which are used in the representation of vowels, is given below:

(43)	Head	Operator	Sharing	Leftward Licensing	Rightward Licensing
I	No	Yes	Yes	No	Yes
U	No	Yes	No	Yes	Yes
A	No	Yes	No	No	No

The first column in (43) shows that all the vowels are headless. I-operator in an onset occupied by a palatalized consonant is shared with the following nucleus. U, however, cannot be shared in the data analyzed in this study. The U-harmonic domain head licenses dependent nuclei both directions, but the I-harmonic domain head can only license nuclei rightwards, and there is no A-licensing in Turkish, that is there is no A-harmony in Turkish.

CHAPTER 6

CONCLUSION

6.1. Summary of the dissertation

The table below shows the elemental composition of Turkish consonants. It is proposed in this thesis that these representations account for stem-final and suffix-initial voicing alternations, word-final consonant clusters, and word-initial and word-final phenomena.

(1)	Stops	Affricates	Fricatives	Sonorants
Voiced	<i>b</i> (U.ɿ) <i>d</i> (A.ɿ) <i>g</i> (ɿ)	<i>c</i> ((A.ɿ)(I))	<i>z</i> (A) <i>j</i> (A.I) <i>v</i> (U)	[ŋ] (L) <i>n</i> (A.L) <i>m</i> (U.L) <i>y</i> (I) <i>r</i> (A) <i>l</i> (A.U)
Voiceless	<i>p</i> (H.U.ɿ) <i>t</i> (H.A.ɿ) <i>k</i> (H.ɿ)	<i>ç</i> ((H.A.ɿ)(I))	<i>s</i> (A.H) <i>f</i> (U.H) <i>h</i> (H) <i>ş</i> (A.H.I)	

The elemental composition of consonants above was suggested in Chapter 3, where the representation of voice was discussed by considering stem-final and suffix-initial voicing alternations. In this study, it was claimed that stem-final voicing alternations can be accounted for by fortition, which strengthens the consonants in the weak onset

position by adding the H element before a final silent nucleus. ? -headed consonants which do not contain H are considered to be weak, and ? -headed onsets with H are strong. Also, final silent nuclei have a weaker status, and phonetically interpreted nuclei are considered to be strong. In the light of the definitions of “weak” and “strong”, it is claimed that weak nuclei require strong stem-final onsets, and this requirement is met through H-fortition. Suffix-initial voicing alternations were explained by claiming H-spreading from the stem final obstruents to the consonant-initial suffixes. In order to account for cases where H spreads to the suffix-initial onset, it is suggested that H requires the presence of ? -head to spread.

In Chapter 4, the composition of Turkish consonants provided above was used to account for word-final consonant clusters. It was discussed which consonants can be good governors and which consonants can be good governees depending on their elemental composition. Headed expressions are regarded to be good governors in general, and headless fricatives *s* and *f* and nasals *m* and *n* can be good governors of the sonorants *r* and *l*. The sequence of consonants in the word-final positions can be accounted for by inter-onset government, except for the sequences in which *s* follows stops, and *ʃ* precedes stops. The unexpected behavior of *s* and *ʃ* was considered as a case of Magic Licensing, type of licensing which is observed cross-linguistically with respect to *s*, since none of the other mechanisms of the phonological ECP explains the silencing of the nucleus between two onsets in these contexts.

In Chapter 5, the relationships between palatalized consonants and nuclei were discussed in relation to word-initial and word-final phenomena. It was claimed that N_1 in Turkish cannot remain silent in Dialect A because it is lexically occupied with I and U, which need to be licensed to be interpreted. N_1 is interpreted in one of

the four ways depending on I-sharing and U-licensing. All the palatalized consonants contain an I-operator, which is shared with the following nucleus.

In the word-final phenomenon, there are three possibilities: i. The pseudo empty nucleus which shares I with palatalized stem-final consonants becomes a harmonic domain head and licenses dependent nuclei, or ii. I-harmonic domain head N_1 or N_2 licenses I in the nuclei in suffixes, iii. U-harmonic domain head in the stem licenses U in the suffixes, or iv. Neither I nor U is licensed.

There are two licensing conditions in Turkish: I-licensing and U-licensing.

(2) I-licensing in Turkish

I-harmonic domain head can license nuclei in the following positions.

(3) U-licensing in Turkish

U-harmonic domain head can license U in the composition of preceding or following nuclei, but the headed onset blocks leftward licensing.

Now, let us summarize some of the claims of this study involving all the chapters. It is claimed in this study that all phonological expressions should be generated by one set of licensing constraints. The following are the licensing constraints proposed in Chapter 3 and discussed in Chapters 4 and 5:

- (4) i. ? must be head.
- ii. H, L and U cannot be head.
- iii. A is not a licensor.

As a result of these licensing constraints, consider the categories which are suggested depending on the elemental composition of consonants:

(5) a. ?-headed	<i>t</i>	<i>d</i>	<i>k</i>	<i>g</i>	<i>p</i>	<i>b</i>
b. I-headed	<i>ʃ</i>	<i>j</i>	<i>y</i>			
c. Complex expressions	<i>ç</i>	<i>c</i>				
d. A-headed	<i>z</i>					
e. Headless	<i>r</i>	<i>l</i>	<i>v</i>	<i>a</i>	<i>o</i>	<i>u</i>
f. Headless with L	[ŋ]	<i>n</i>	<i>m</i>			
g. Headless with H	<i>s</i>	<i>f</i>	<i>h</i>			
h. Headless with I	<i>i</i>	<i>ö</i>	<i>ü</i>	<i>e</i>		

In the list above, all the phonological expressions are categorized according to their elemental composition. As proposed in Chapter 3, the consonants in (5 a and c) undergo voicing alternations in stem-final and suffix-initial positions. As discussed in Chapter 4, the consonants in (5 a, b, c and d) make good governors. There are also vowels in (5 e and h) since they are headless. The consonants (5 e) and in (5 f) make good governees, but *m* and *n* can also be good governors of *l* and *r*. The fricatives *s* and *f* can be either governors or governees. In (5 h), there are vowels which contain I in their compositions. Note that palatalized consonants, which contain I in their composition, are not listed in the list above since all the consonants except true palatals can be palatalized.

Consider the following table summarizing the behavior and properties of elements in Turkish.

(6)	Onset	Nucleus	Head	Operator	Sharing	Leftward Licensing	Rightward Licensing
I	Yes	Yes	Yes	Yes	Yes	No	Yes
U	Yes	Yes	No	Yes	No	Yes	Yes
H	Yes	No	No	Yes	No	No	Yes
A	Yes	Yes	Yes	Yes	No	No	No
ʔ	Yes	No	Yes	No	No	No	No
L	Yes	No	No	Yes	No	No	No

In the first column in (6), it can be seen that all the elements are used in the representation of consonants by occupying an onset position. However, only A, I and U can be present in the composition of a nucleus. In the third and fourth columns, it is stated that ʔ is always head, and I and A can be either head or operator, whereas, the others cannot be heads.

As can be seen in the table above, the elements I, U and H can license the same elements in the other positions in Turkish. Element licensing is used here to refer to harmonic relationships between elements in the compositions of phonological expressions. In other words, harmony is considered to be a licensing relationship between nucleus to nucleus, onset to onset, onset to nucleus and nucleus to onset. The element I and U seem to have a special place among other elements in terms of their behavior in Turkish.

This thesis contributes to the field of Turkish phonology by looking at some phonological phenomena concerning consonants from a Government Phonology perspective. Voicing alternations, consonant clusters and the role of palatalized consonants in word-initial and word-final phenomena are analyzed with a new outlook in this study. It is claimed that the analyses of these phenomena are explanatory rather than only descriptive, which should be the aim of any phonological theory. Being the first study on the representations of all Turkish consonants in GP terms, and being one of the few studies on the elemental

composition of consonants, it strengthens the element theory by suggesting the composition of Turkish consonants by using the minimalist 6 element framework.

6.2. Remaining problems and implications for further studies

There are some potential problems with having minimal number of elements. It is claimed in this study that friction is represented with the lack of the stop element \emptyset . However, fricatives are not the only consonants which are not represented with \emptyset , there are sonorants as well. In the second chapter, the problem of differentiating sonorants from voiced fricatives is discussed in some length. However, this is one of the subjects for further studies.

Another area which needs a more in-depth research is the licensing constraints in accounting for the phenomena concerning consonants. Licensing constraints for vowels seem to account for harmony facts in many languages. However, licensing constraints can fail to eliminate all expressions which may not be needed. In this study, not all unused expressions can be deleted by the licensing constraints suggested. The main reason for this is that the elements I and A are used in two roles, i.e. as a head and an operator. There might be a way to be able to do that and to have the expressions used in that language exclusively by using licensing constraints, which is also in the domain of further research.

There are some phonological phenomena related to interactions between consonants and vowels, which cannot be easily accounted for by the elemental composition suggested here. For example, the phenomenon called “vowel raising” where $[e]$ is in free variation with $[\varepsilon]$ before the consonants l , m , n and r is one of them. Although the elemental composition of consonants does not offer a direct

answer, these consonants share three significant compositional similarities according to our representations: i. all of these expressions are headless, ii. they do not contain H, ʔ or I, and iii. they all consist of one or two of the elements A, U and L (Göksel, personal communication). Even though these characteristics help us to define the group of consonants involved in the phonological process, they do not account for the variation in the pronunciation of *e*. The prediction we can make is that adjacent vowels to sonorants without I undergo this phonetic process. The complete analysis of this subject is also beyond the scope of this thesis.

Another such phenomenon could be called “A-reduction”. The element A is sometimes not interpreted before phonological expressions containing I-head. In this study, we discussed different ways how I-operator plays a role in interactions between consonants and vowels. As proposed in Chapter 3, *y* and *c* are represented with I-head since they are true palatals. To exemplify, I-head in *y* as in *-yor* ‘Pres.’ causes A-reduction in the stem it attaches to, as in *gel-mi-yor* ‘come+Neg.+Pres.’ and I-head in *c* as in *bekli-cek* ‘wait+Fut.’ plays a role in the non-interpretation of preceding A element in spoken Turkish. Our proposed elemental composition sheds light on the issue in terms of the effect of an onset on a nucleus. However, how this phonological process takes place need to be explored in further studies.

In this study, the aim has been to account for as many examples of a phenomenon as possible. However, some words do not follow the majority of their group. It is a general problem with phonological research to consider some concrete data as exceptions. In a language like Turkish, where there are many loan words from different languages with various phonological and lexical peculiarities, although most loan words comply with the phonological principles of Turkish phonology. The question is whether phonology should have abundant language

specific principles, rules and constraints to account for all the data without exceptions, or whether there should be universal principles and parameters to explain language-specific data with few exceptions. The latter has been preferred in this study.

REFERENCES

- Aksan, D., Atabay, N., Özel, S., Çam, A. & Pirali, N. (1978). *Türkiye Türkçesi Gelişmeli Sesbilimi*. Ankara: Ankara Üniversitesi Basımevi.
- Anderson, J. & Jones, C. (1974). Three theses concerning phonological representations. *Linguistic Inquiry* 10: 1-23.
- Archangeli, D. (1988). Aspects of underspecification theory. *Phonology* 5. 183-207.
- Backley, P. & Takahashi, T. (1998). Element activation. *Structure and interpretation: studies in Phonology*. E. Cyran (ed.). Lublin: Folium. 13-40.
- Beckman, J. & Ringen, C. (2004). Contrast and redundancy in Optimality Theory. In *WCCFL 23 Proceedings*. V. Chand, A. Kelleher, A. J. Rodríguez, & B. Schmeiser (eds.). Somerville, MA: Cascadilla Press. 85-98.
- Blevins, J. (2005). Final Devoicing: A family of Facts. Presentation in MFM 13. 28 May 2005.
- Brockhaus, W. (1995). Skeletal and suprasegmental structure in GP. In *Frontiers of Phonology: Atoms, structures, derivations*. J. Durand & F. Katamba (eds.). New York, London: Longman. 180-121.
- Brockhaus, W. (1999). *The syllable in German: Exploring an alternative*. In *The Syllable: Views and Facts*, Studies in Generative Grammar 45. H. van der Hulst & N. Ritter (eds.). Berlin and New York: Mouton de Gruyter. 170-206.
- Charette, M. (1990). License to govern. *Phonology* 7: 233-254.
- Charette, M. (1991). *Conditions on phonological government*. Cambridge: Cambridge University Press.

- Charette, M. (1992). Mongolian and Polish meet government licensing. *SOAS Working Papers in Linguistics and Phonetics 2*: 275-291.
- Charette, M. (1998). Empty and pseudo-empty categories. *SOAS Working Papers in Linguistics and Phonetics 8*: 167-176.
- Charette, M. & Göksel, A. (1996). Switching and vowel harmony in Turkic languages. *SOAS working papers in Linguistics and Phonetic 6*: 31-52.
- Charette, M. & Göksel, A. (1998). Licensing constraints and vowel harmony in Turkic languages. In *Structure and interpretation: Studies in phonology*. E. Cyran (ed.). Lublin: Folium. 65-88.
- Clements, G. N. & Sezer, E. (1982). Vowel and Consonant disharmony in Turkish. In *The structure of phonological representations, vol II*. Hulst & Smith (eds.). Dordrecht: Foris. 213-235
- Cobb, M. (1997). *Conditions on Nuclear Expressions in Phonology*. Ph.D. thesis, SOAS, London.
- Demircan, Ö. (1979). *Türkiye Türkçesinin Ses Düzeni ve Türkiye Türkçesindeki Sesler*. Ankara: Türk Dil Kurumu Yayınları.
- Demircan, Ö. (1996). *Türkçe'nin Seseşizimi*. İstanbul: Der Yayınları.
- Denwood, M. A. (1997 a). Harmony: Three for the Price of One. *SOAS Working Papers in Linguistics and Phonetics 7*: 193-207.
- Denwood, M. A. (1997 b). *The role of the Element I in Khalkha Mongolian*. Ph.D. thesis, SOAS, University of London.
- Denwood, M. A. (1998). A Template for Turkish. *SOAS Working Papers in Linguistics and Phonetics 8*: 177-190.
- Denwood, M. A. (2002). K-Ø: morpho-phonology in Turkish. *SOAS Working Papers in Linguistics and Phonetics 12*: 89-98.

- Denwood, M. A. (2003). Template and Morphology in Khalkha Mongolian, and beyond. In *Living on the Edge: 28 Papers in Honour of Jonathan Kaye*, Studies in Generative Grammar 63. S. Ploch (ed.). Berlin, New York: Mouton de Gruyter. 543-562.
- Ergenç, İ. (1989). *Türkiye Türkçesinin Görevsel Sesbilimi*. Ankara: Türk Dil Kurumu Yayınları.
- Ergenç, İ. (1995). *Konuşma Dili ve Türkçenin Söyleyiş Sözlüğü*. Ankara: Simurg.
- Erguvanlı-Taylan, E. (unpublished class notes). *Structure of Modern Turkish*. Class Notes.
- Foster, J. F. (1969). *On some phonological rules of Turkish*. Ph.D. Dissertation, University of Illinois.
- Gibb, L. (1992). *Domains in Phonology: with evidence from Icelandic, Finnish and Kikuyu*. Ph.D. thesis, University of Edinburgh.
- Goh, Y. (1997). *The segmental phonology of Beijing Mandarin*. Taipei: Crane Publishing Co.
- Goldsmith, J. A. (1990). *Autosegmental and Metrical Phonology*. London: Blackwell Publishers.
- Göksel, A. & Kerslake, C. (2005). *Turkish: A Comprehensive Grammar*. London and New York: Routledge.
- Grijzenhout, J. (2000 a). Voicing and Devoicing in German, English and Dutch; evidence for domain specific identity constraints. *SFB 282*, Working paper no. 116. HHU, Düsseldorf.
- Grijzenhout, J. (2000 b). Final devoicing and voicing assimilation in Dutch derivation and cliticization. *SFB 282*, Working Paper No. 106. HHU, Düsseldorf.

- Gussmann, E. & Kaye, J. (1993). Polish notes from a Dubrovnik café, I. *SOAS Working Papers in Linguistics & Phonetics* 3. M. Cobb & J. Yan (eds.). 427-462.
- Harris, J. (1990). Segmental Complexity and Phonological Government. *Phonology* 7: 255-300.
- Harris, J. (1992). Licensing Inheritance. *UCL Working Papers in Linguistics* 4: 359-406.
- Harris, J. (1996). Phonological output is redundancy free and fully interpretable. *UCL Working Papers in Linguistics* 8: 551-574.
- Harris, J. (1997). Licensing Inheritance: an integrated theory of neutralization. *Phonology* 14: 315-370.
- Haworth, E. (1994). The trouble with French glides. *SOAS Working Papers in Linguistics and Phonetics* 4: 53-70.
- Hulst, van der H. & Weijer, van de, J. (1991) Topics in Turkish phonology. In *Turkish Linguistics Today*. H. Boeschoten & L. Verhoeven, (eds.). Leiden: Brill. 11-69.
- Inkelas, S. (1994). The consequences of optimization for underspecification. Ms. University of California, Berkeley, Rutgers Optimality Archive ROA-40-1294.
- Inkelas, S. (1995). The consequences of Optimization for Underspecification. In *Proceedings of North East Linguistics Society* 25. J. N. Beckman (ed.). Amherst, Mass: GLSA. 287-302.
- Inkelas, S. (1999). Exceptional stress-attracting suffixes in Turkish: representations vs. the grammar. In *The Prosody Morphology Interface*. R. Kager, H. van der

- Hulst & W. Zonneveld (eds.). Cambridge: Cambridge University Press. 134-187.
- Inkelas, S. & Orgun, O. (1994). Level economy, derived environment effects and the treatment of exceptions. In *Recent Developments in Lexical Phonology*. R. Wiese (ed.). Heinrich Heine Universität, Düsseldorf. 63-90.
- Inkelas, S. & Orgun, O. (1995) Level ordering and economy in the lexical phonology of Turkish. *Language 71*: 763-93.
- Jensen, S. (1994). Is ? an element? Towards a non-segmental phonology. *SOAS Working Papers in Linguistics and Phonetics 4*: 193-231.
- Kallestinova, E. (2004). Voice and aspiration of stops in Turkish. *Folia Linguistica Europa 38*: 117-143.
- Kaisse, E. M. (1992). Can [consonantal] spread? *Language 68*: 313-332.
- Kaye, J. (1989) *Phonology: a cognitive view*. New Jersey: Lawrence Erlbaum Associates.
- Kaye, J. (1990). 'Coda' Licensing. *Phonology 7*: 301-330.
- Kaye, J. (1992). Do you believe in magic? The story of s+C sequences. *SOAS Working Papers in Linguistics and Phonetics 2* : 293-313.
- Kaye, J. (1995). Derivations and interfaces. In *Frontiers of phonology: atoms, structures, derivations*, J. Durand & F. Katamba (eds.). London: Longman. 289-332.
- Kaye, J. (2000). A users' guide to Government Phonology. Ms., University of Ulster.
- Kaye, (2001). Working with licensing constraints. In *Constraints and Preferences*, K. Dziubalska-Kolaczyk (ed.). Berlin & New York: Mouton de Gruyter. 251-268.
- Kaye, J. Lowenstamm, J. & Vergnaud, R. (KLV) (1990). Constituent Structure and

- Government in Phonology. *Phonology* 7: 193-231.
- Kean, M. L. (1974). The strict cycle in Phonology. *Linguistic Inquiry* 5: 179-203.
- Kenstowicz, M. (1994). *Phonology in Generative Grammar*. Cambridge, Mass.: Blackwell Publishers.
- Kim, S. J. (1996). *The representations of Korean phonological expressions and their consequences*. Ph.D. Thesis, University of London.
- Kiparsky, P. (1985). Some consequences of lexical phonology. *Phonology Yearbook* 2: 85-138.
- Kiparsky, P. (1998). Partitive case and aspect. In *The Projection of Arguments: Lexical and Compositional Factors*. M. Butt & W. Geuder (eds.). Stanford: CSLI Publications. 265-308.
- Kornfilt, J. (1997). *Turkish*. London: Routledge.
- Kula, N. C. (2002). *The phonology of verbal derivation in Bemba*. Utrecht: LOT Publication.
- Leben, W. (1973). *Suprasegmental phonology*. Ph.D. Dissertation, MIT.
- Lewis, G. (1967). *Turkish Grammar*. Oxford: Oxford University Press.
- Lombardi, L. (2004) Positional Faithfulness and Voicing Assimilation in Optimality Theory. In *Optimality Theory in Phonology*, J. McCarthy (ed.). New York: Blackwell Publishers. 267-301.
- Lowenstamm, J. (1996). CV as the only syllable type. In *Current trends in Phonology. Models and Methods*. J. Durand, & B. Laks (eds.). Manchester: Salford. 419-441.
- McCarthy, J. & Prince, A. (1993). *Prosodic Morphology: Constraint Interaction and Satisfaction*. New Brunswick: Rutgers University Press.
- Nasukawa, K. (1997). Melodic structure in a nasal-voice paradox. *UCL Working*

Papers in Linguistics 9: 1-23.

- Nasukawa, K. (2000). *A unified approach to nasality and voicing*. Doctoral dissertation, University College London.
- Orgun, O. (2004). Metrical faithfulness. Presentation in WAFLE 2.
- Ploch, S. (1996). *The representation of English consonants*. Class Notes.
- Ploch, S. (1998). Non-switch harmony in Yawelmani (and Turkish and Yakha).
SOAS Working Papers in Linguistics and Phonetics 8: 209-238.
- Rhee, S.J. (1996). *Consonantal aspects of Government Phonology: lenition and fortition in Korean*. Ph.D. thesis, University of London.
- Rowicka, G. (1999). On trochaic Proper Government. In *Phonologica 1996. Syllables*. J. Rennison & K. Kühnhammer (eds.). Hague: Holland Academic Graphics, 273-88.
- Selen, N. (1979). *Söyleyiş Sesbilim, Akustik Sesbilim ve Türkiye Türkçesi*. Ankara: Ankara Üniversitesi Basımevi.
- Sezer, E. (1981). The k-Ø alternation in Turkish. In *Harvard Studies in Phonology, Vol. II*. G. N. Clements (ed.). Reproduced by the Indiana University Linguistics Club. 354 – 382.
- Sheer, T. (2004). *Volume 1: What is CVCV and Why should it be?* Berlin and New York: Mouton de Gruyter.
- Underhill, R. (1976). *Turkish Grammar*. Cambridge, MA: MIT Press.
- Wiese, R. (1996). *The phonology of German*. Oxford: Clarendon Press.
- Yavaş, M. (1980). Vowel and Consonant Harmony in Turkish. *Glossa 14, 2: 189-211.*
- Yoshida, S. (1993). Licensing of empty Nuclei: The case of Palestinian vowel harmony. *The Linguistic Review 10: 127-159.*