

STUDENTS' ACCEPTANCE OF AND  
INTENTION TO USE LEARNING MANAGEMENT SYSTEMS  
USING EXTENDED TAM



MÜYESSER ERASLAN YALÇIN

BOĞAZIÇI UNIVERSITY

2018

STUDENTS' ACCEPTANCE OF AND  
INTENTION TO USE LEARNING MANAGEMENT SYSTEMS  
USING EXTENDED TAM

Thesis submitted to the  
Institute of Graduate Studies in Social Sciences  
in partial fulfillment of the requirements for the degree of

Master of Arts  
in  
Management Information Systems

by  
Müyesser Eraslan Yalçın

Boğaziçi University

2018

Students' Acceptance of and Intention to Use  
Learning Management Systems Using Extended TAM

The thesis of Müyesser Eraslan Yalçın  
has been approved by:

Prof. Birgül Kutlu Bayraktar  
(Thesis Advisor)

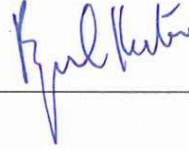

Prof. Zuhâl Tanrıkulu

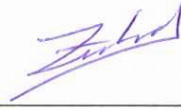

Assist. Prof. Eylem İlker Oyman  
(External Member)

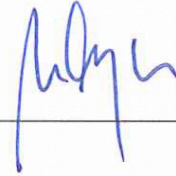

January 2018

## DECLARATION OF ORIGINALITY

I, Müyesser Eraslan Yalçın, certify that

- I am the sole author of this thesis and that I have fully acknowledged and documented in my thesis all sources of ideas and words, including digital resources, which have been produced or published by another person or institution;
- this thesis contains no material that has been submitted or accepted for a degree or diploma in any other educational institution;
- this is a true copy of the thesis approved by my advisor and thesis committee at Boğaziçi University, including final revisions required by them.

Signature..... *M Eraslan* .....

Date ..... *12.01.18* .....

## ABSTRACT

Students' Acceptance of and Intention to Use Learning Management Systems

Using Extended TAM

The aim of this study is to examine students' acceptance of and intention to use learning management systems for university education in Turkey using extended Technology Acceptance Model (e-TAM) that allows to find the dominant reason(s)/ factor(s) for learners when using a system. According to literature review, the factors are determined as Behavioral Intention to Use (BIU), Perceived Usefulness (PU), Perceived Ease of Use (PEOU), Perceived Interaction (PI), Social Norm (SN), Compatibility with Preferred Work Style (CPWS), User Interface Design (UID), Computer Self-Efficacy (CSE), and Previous Online Learning Experience (POLE).

To measure the effects of these factors, a questionnaire, composed of two parts: the items of demographic information and the items of variables, is distributed both by online and by hand. The study is conducted at two different places: Istanbul Bilgi University (56.73%) and Boğaziçi University (43.26%). The total sample of the study is 282. 43.3% of the participants are female and 56.7% of them are male. The data that was collected from the questionnaires were transferred to Excel and then transferred to Statistical Package for Social Sciences (SPSS) Version 20 and SPSS Amos 23 for SEM analysis.

The results show that BIU is affected from PU, PEOU, and SN, PU is affected from PEOU, SN, UID, and finally PEOU is affected from UID and CSE.

## ÖZET

Öğrencilerin Öğrenme Yönetim Sistemlerini Kabul ve Kullanma Niyetini

Genişletilmiş TKM Kullanarak Araştırma

Bu çalışmanın amacı, Türkiye’deki üniversite eğitimi için öğrencilerin öğrenme yönetim sistemlerini kabul ve kullanma niyetini, bir sistemi kullanan öğrenen kişiler için egemen neden(leri)/ faktör(leri) bulmaya imkan tanıyan genişletilmiş Teknoloji Kabul Methodu (TKM) ile araştırmaktır. Literatür taramasında göre, faktörler Davranışsal Kullanma Niyeti (DKN), Algılanan Kullanışlılık (AK), Algılanan Kullanım Kolaylığı (AKK), Algılanan Etkileşim (AE), Sosyal Norm (SN), Tercih Edilen Çalışma Stili ile Uyumluluk (TEÇSU), Kullanıcı Ara yüz Dizaynı (KAD), Bilgisayar Öz Yeterliliği (BÖY), ve Önceki Çevrimiçi Öğrenme Deneyimi (ÖÇÖD) olarak belirlenmiştir.

Bu faktörlerin etkilerini ölçmek için, iki parçadan oluşan: değişkenlerin ögeleri ve demografik bilgilerin ögeleri, bir anket hem çevrimiçi hem de elden dağıtılmıştır. Çalışma iki farklı yerde; İstanbul Bilgi Üniversitesi (%56.73) ve Boğaziçi Üniversitesi (%43.26) yürütülmüştür. Çalışmanın toplam örneği 282’dir. Katılımcıların %43.3’ü kadın ve %56.7’si erkektir. Anketlerden toplanan veri Excel’e aktarılmıştır ve sonra 20 Versiyonlu Sosyal Bilimler için İstatistik Paketi (SBİP)’ne ve YEM analizi için SBİP Amos 23’e aktarılmıştır.

Sonuçlar, DKN’nin AK, AKK ve SN’den etkilendiğini, AK’nın AKK, SN, KAD’dan etkilendiğini ve son olarak AKK’nın KAD ve BÖY’den etkilendiğini göstermiştir.

## ACKNOWLEDGEMENTS

The first, I am grateful to my thesis supervisor, Prof. Dr. Birgöl Kutlu Bayraktar, for her guidance, patience, effort, advice, and all support. This thesis could not have been completed without her. I also wish to thank Prof. Dr. Zuhâl Tanrıkulu and Assist. Prof. Eylem İlker Oyman, my thesis committee members, who devoted their valuable time and energy to this study.

I cannot thank enough my beloved husband, Enver Yalçın, for sharing all kinds of distress and happiness, and for not leaving me for a moment in the most unbearable situations. Also, I will never forget his encouragement, help, support, or his believing in me.

I am thankful to my daughter, Latife Yasemin Yalçın, who was born during the development of this thesis. Sometimes this made situations challenging, but she always gives me happiness.

I thank all of my family members for to their generous help and continuing support that resulted in the completion of this thesis.

I also appreciate my friends Çağla Demir and Esra Başođlu for their help collecting data at Bilgi University and Dr. Özge Kirezli for guidance and moral support.

Finally, I dedicate my thesis to my grandmother, Huriye Eraslan, and my grandfather, Mehmet Eraslan, who gave me moral and material support.

## TABLE OF CONTENTS

CHAPTER 1: INTRODUCTION .....	1
CHAPTER 2: LITERATURE REVIEW .....	3
2.1 Definition of e-learning .....	3
2.2 Benefits of e-learning .....	3
2.3 Definition of LMS .....	4
2.4 Features of LMS .....	5
2.5 Types of LMSs .....	7
2.6 The adoption and implementation of an LMS .....	9
2.7 General view of TAM .....	12
2.8 Structural equation modeling (SEM) .....	35
CHAPTER 3: THEORETICAL FRAMEWORK AND HYPOTHESES .....	37
3.1 Theoretical framework .....	37
3.2 Hypotheses .....	38
CHAPTER 4: METHODOLOGY .....	45
4.1 Research design .....	45
4.2 Items in the questionnaire .....	46
4.3 Population and sample .....	46
4.4 Data analysis tools .....	48
CHAPTER 5: ANALYSIS AND FINDINGS .....	49
5.1 Descriptive findings .....	49
5.2 Reliability / internal consistency of the survey items and scales .....	58
5.3 Hypotheses testing .....	61



5.4 Final model for regression analysis.....	97
5.5 Structural equation modeling (SEM) results.....	98
CHAPTER 6: DISCUSSION AND CONCLUSIONS .....	114
6.1 Discussion .....	115
6.2 Limitations of the study .....	120
6.3 Suggestions for future work .....	121
APPENDIX A: QUESTIONNAIRE.....	122
APPENDIX B: RELIABILITY ANALYSIS OUTPUTS .....	128
APPENDIX C: GROUP DIFFERENCES ABOUT BIU AN LMS .....	131
APPENDIX D: SEM ANALYSIS OUTPUTS.....	133
REFERENCES.....	137

## LIST OF TABLES

Table 1. Sources of Items in the Questionnaire .....	47
Table 2. The Female-Male Rate that are Included in This Study .....	49
Table 3. Year in the University .....	49
Table 4. The Departments Included in This Study .....	50
Table 5. Descriptive Analysis of the Age of Sample .....	51
Table 6. LMS Experience per Day, LMS Experience and Internet and Computer Experience.....	52
Table 7. Mean Values of Behavioral Intention to Use LMS.....	53
Table 8. Mean Values of Perceived Usefulness.....	53
Table 9. Mean Values of Perceived Ease of Use .....	54
Table 10. Mean Values of Perceived Interaction .....	55
Table 11. Mean Values of Social Norm.....	55
Table 12. Mean Values of Compatibility with Preferred Work Style.....	56
Table 13. Mean Values of User Interface Design.....	57
Table 14. Mean Values of Computer Self-Efficacy .....	57
Table 15. Mean Values of Previous Online Learning Experience.....	58
Table 16. Cronbach's Alpha Values of All Scales.....	59
Table 17. Model Summary for Hypothesis 1 .....	62
Table 18. ANOVA <sup>a</sup> for Hypothesis 1 .....	62
Table 19. Coefficients <sup>a</sup> for Hypothesis 1 .....	63
Table 20. Model Summary for Hypotheses 2 .....	63
Table 21. ANOVA <sup>a</sup> for Hypotheses 2.....	64

Table 22. Coefficients <sup>a</sup> for Hypotheses 2.....	64
Table 23. Model Summary for Hypothesis 3 .....	65
Table 24. ANOVA <sup>a</sup> for Hypothesis 3 .....	65
Table 25. Coefficients <sup>a</sup> for Hypothesis 3 .....	66
Table 26. Model Summary for Hypothesis 4 .....	66
Table 27. ANOVA <sup>a</sup> for Hypothesis 4 .....	67
Table 28. Coefficients <sup>a</sup> for Hypothesis 4 .....	67
Table 29. Model Summary for Hypothesis 5 .....	68
Table 30. ANOVA <sup>a</sup> for Hypothesis 5 .....	68
Table 31. Coefficients <sup>a</sup> for Hypothesis 5 .....	69
Table 32. Model Summary for Hypothesis 6 .....	69
Table 33. ANOVA <sup>a</sup> for Hypothesis 6 .....	70
Table 34. Coefficients <sup>a</sup> for Hypothesis 6 .....	70
Table 35. Model Summary for Hypothesis 7 .....	71
Table 36. ANOVA <sup>a</sup> for Hypothesis 7 .....	71
Table 37. Coefficients <sup>a</sup> for Hypothesis 7 .....	72
Table 38. Model Summary for Hypothesis 8 .....	72
Table 39. ANOVA <sup>a</sup> for Hypothesis 8 .....	73
Table 40. Coefficients <sup>a</sup> for Hypothesis 8 .....	73
Table 41. Model Summary for Hypothesis 9 .....	74
Table 42. ANOVA <sup>a</sup> for Hypothesis 9 .....	74
Table 43. Coefficients <sup>a</sup> for Hypothesis 9 .....	75
Table 44. Model Summary for Hypothesis 10 .....	75
Table 45. ANOVA <sup>a</sup> for Hypothesis 10 .....	76

Table 46. Coefficients <sup>a</sup> for Hypothesis 10 .....	76
Table 47. Model Summary for Hypothesis 11 .....	77
Table 48. ANOVA <sup>a</sup> for Hypothesis 11 .....	77
Table 49. Coefficients <sup>a</sup> for Hypothesis 11 .....	78
Table 50. Model Summary for Hypothesis 12 .....	78
Table 51. ANOVA <sup>a</sup> for Hypothesis 12 .....	79
Table 52. Coefficients <sup>a</sup> for Hypothesis 12 .....	79
Table 53. Model Summary for Hypothesis 13 .....	80
Table 54. ANOVA <sup>a</sup> for Hypothesis 13 .....	80
Table 55. Coefficients <sup>a</sup> for Hypothesis 13 .....	81
Table 56. Model Summary for Hypothesis 14 .....	81
Table 57. ANOVA <sup>a</sup> for Hypothesis 14 .....	82
Table 58. Coefficients <sup>a</sup> for Hypothesis 14 .....	82
Table 59. Model Summary for Hypothesis 15 .....	83
Table 60. ANOVA <sup>a</sup> for Hypothesis 15 .....	83
Table 61. Coefficients <sup>a</sup> for Hypothesis 15 .....	84
Table 62. Model Summary for Hypothesis 16 .....	84
Table 63. ANOVA <sup>a</sup> for Hypothesis 16 .....	85
Table 64. Coefficients <sup>a</sup> for Hypothesis 16 .....	85
Table 65. Model Summary for Hypothesis 17 .....	86
Table 66. ANOVA <sup>a</sup> for Hypothesis 17 .....	86
Table 67. Coefficients <sup>a</sup> for Hypothesis 17 .....	87
Table 68. Model Summary for Hypothesis 18 .....	87
Table 69. ANOVA <sup>a</sup> for Hypothesis 18 .....	88

Table 70. Coefficients <sup>a</sup> for Hypothesis 18 .....	88
Table 71. Summary of SPSS Hypotheses Test Results.....	89
Table 72. Group Statistics of Gender.....	90
Table 73. Independent Samples Test for Gender .....	90
Table 74. Group Statistics of University Differences .....	91
Table 75. Independent Samples Test for University Differences .....	91
Table 76. Group Statistics of LMS Differences.....	92
Table 77. Independent Samples Test for LMS Differences.....	92
Table 78. Descriptives for Educational Level according to BIU an LMS .....	93
Table 79. ANOVA for Educational Level according to BIU an LMS.....	93
Table 80. Factor Analysis for BIU.....	94
Table 81. Factor Analysis for PU.....	94
Table 82. Factor Analysis for PEOU .....	94
Table 83. Factor Analysis for PI .....	95
Table 84. Factor Analysis for POLE.....	95
Table 85. Factor Analysis for UID.....	96
Table 86. Factor Analysis for SN.....	96
Table 87. Factor Analysis for CPWS.....	96
Table 88. Factor Analysis for CPWS.....	97
Table 89. Factor Analysis for CSE .....	97
Table 90. Confirmatory Factor Analysis Results.....	102
Table 91. Convergent and Discriminant Validity Values .....	103
Table 92. Model Fit Values for Figure 23.....	105
Table 93. Model Fit Values with Deleted Constructs .....	105

Table 94. Regression Weights before the Removal of Hypotheses of CSE ..... 107

Table 95. Regression Weights after the Removal of Hypotheses of CSE ..... 108

Table 96. Final Convergent and Discriminant Validity Values ..... 108

Table 97. P Values for Every Hypothesis ..... 111

Table 98. P Values for Every Hypothesis ..... 112



## LIST OF FIGURES

Figure 1. Original technology acceptance model (TAM) (Davis, 1986) .....	12
Figure 2. Bajaj and Nidumolu (1998) e-TAM .....	14
Figure 3. Karahanna et al. (2006) e-TAM.....	15
Figure 4. Sanchez and Hueros (2010) e-TAM .....	16
Figure 5. Liu et al. (2010) e-TAM .....	17
Figure 6. Escobar-Rodriguez and Monge-Lozano (2012) e-TAM .....	19
Figure 7. Iglesias-Pradas et al. (2014) e-TAM.....	20
Figure 8. Tarhini et al. (2013) e-TAM .....	21
Figure 9. Tarhini et al. (2014) e-TAM .....	22
Figure 10. Ros et al. (2015) e-TAM.....	23
Figure 11. Mouakket and Bettayeb (2015) study model.....	25
Figure 12. Abdullah and Ward (2016) e-TAM .....	26
Figure 13. Kilic (2014) e-TAM.....	28
Figure 14. Acarli and Saglam (2015) TAM2 .....	30
Figure 15. Tosuntas et al. (2015) UTAUT model.....	31
Figure 16. Sezgin and Ozkan-Yildirim (2016) P-TAM .....	32
Figure 17. Kurfali et al. (2017) UTAUT model.....	34
Figure 18. SEM analysis example.....	36
Figure 19. Theoretical framework.....	38
Figure 20. Final model for regression analysis with path values .....	98
Figure 21. A flowchart of the incremental approach to SEM (Cheng, 2001).....	99
Figure 22. Amos covariance diagram for measurement model .....	100

Figure 23. Hypothesized structural model ..... 106

Figure 24. Final best fitting structural model..... 107

Figure 25. Final model ..... 110





## LIST OF APPENDIX TABLES

Table B1. Reliability Analysis for BIU Scale.....	128
Table B2. Reliability Analysis for PU Scale.....	128
Table B3. Reliability Analysis for PEOU Scale .....	128
Table B4. Reliability Analysis for PI Scale .....	129
Table B5. Reliability Analysis for SN Scale.....	129
Table B6. Reliability Analysis for CPWS Scale.....	129
Table B7. Reliability Analysis for UID Scale.....	129
Table B8. Reliability Analysis for CSE Scale .....	130
Table B9. Reliability Analysis for POLE Scale.....	130
Table C1. T-test for Gender Differences on BIU an LMS.....	131
Table C2. T-test for University Differences on BIU an LMS .....	131
Table C3. T-test for LMS Differences on the Behavioral Intention to Use an LMS.....	132
Table D1. Factor Loadings for Measurement Model.....	133
Table D2. Assessment of Normality for Measurement Model .....	134
Table D3. CMIN .....	135
Table D4. RMR, GFI .....	135
Table D5. Baseline Comparisons.....	135
Table D6. Parsimony-Adjusted Measures .....	135
Table D7. NCP .....	135
Table D8. FMIN.....	136
Table D9. RMSEA .....	136
Table D10. AIC.....	136

Table D11. ECVI ..... 136

Table D12. HOELTER ..... 136



## ABBREVIATIONS

AMOS: Analysis of Moment Structures

AVE: Average Variance Extracted

CFA: Confirmatory Factor Analysis

CR: Composite Reliability

CPWS: Compatibility with Preferred Work Style

CSE: Computer Self-Efficacy

E-TAM: Extended Technology Acceptance Model

LMS: Learning Management System

OSS: Open Source Software

PU: Perceived Usefulness

PEOU: Perceived Ease of Use

PI: Perceived Interaction

POLE: Previous Online Learning Experience

SEM: Structural Equation Modeling

SN: Social/Subjective Norm

SPSS: Statistical Package for Social Sciences

TAM: Technology Acceptance Model

UID: User Interface Design

# CHAPTER 1

## INTRODUCTION

Technology is a part of our lives and the usage of it has grown enormously in the last years. In every field, technology takes place and is developed day by day. In educational place, e-learning is started commonly to be used and is such a technology that allows to share documents, to provide interactions between instructors and learners or learners and learners without any time or place restriction (Liaw, 2008; Sanchez & Hueros, 2010; Momani, Emad, & Ababneh, 2012).

Learning Management System (LMS) is used as a software application to control the e-learning environment. It is used by the instructors to create and deliver content, monitor students' participation, and assess their performance online and by students to download materials, interact with instructors and peers (Alias & Zainuddin, 2005). Thus, learners' learning experience and academic success will be increasing if they accept such technology (Park, 2009; Tarhini, Hone, & Liu, 2014). Finding the factors of acceptance is significant to improve the learning environment and to attract learners to continue to use it as a part of educational life (Park, 2009).

Therefore, in order to get the exact and the proper information it is necessary to conduct research for finding the factors of learners' intention to use e-learning systems. These factors may include personal factors, such as perceived usefulness, perceived ease of use, perceived interaction, previous online learning experience, computer self-efficacy, compatibility with preferred work style together with social factors such as social/subjective norm and organizational factors such as user-interface design (Park, 2009).

The main purpose of this research was to examine students' acceptance of and intention to use learning management systems for university education in Turkey using extended Technology Acceptance Model (e-TAM). By applying e-TAM, it is expected to discover the dominant reason(s)/ factor(s) for learners when using a relatively new system. Questionnaires are distributed either online on the Internet or as printed copies during class or lecture time in order to collect the data. The questionnaire in this study contains total of 9 factors that will be introduced in Chapter 3 as detailed.

This study is organized as follows. Chapter 1 describes an introduction that includes general view of the study, the aim, and the study structure. Chapter 2 contains literature review about previous relevant studies, for instance, empirical studies about e-learning technology and LMS, theory of Technology Acceptance Model (TAM), and Structural Equation Modeling (SEM). Chapter 3 is about the theoretical framework that explains the research model development, proposed hypotheses and the questionnaire design. Chapter 4 explains the methodology. Chapter 5 reveals the respondent demography, questionnaire analysis and research findings. Finally, Chapter 6 draws the conclusion of the research, specifies the limitations and the recommendations for future studies.

## CHAPTER 2

### LITERATURE REVIEW

#### 2.1 Definition of e-learning

Technology is very important for people's lives as it helps them and simplifies what they do. In educational context, e-learning represents technology. There is no common definition for e-learning that stands for electronic learning. E-learning is a tool that uses computer network technology to make it easy for users to reach necessary material for educational purposes (Momani et al., 2012; Abdullah & Ward, 2016). E-learning is online learning offering tools such as e-mail, online discussions, forums, online quizzes, assignments and instructional materials such as audio, video, and text mediums (Arkorful & Abaidoo, 2015; Abdullah & Ward, 2016).

E-learning is a way to reach all course related resources via electronic media such as Internet (Wang, Wang, & Shee, 2007; Selim, 2007; Park, 2009; Abu-Shanab & Ababneh, 2015; Arkorful & Abaidoo, 2015) and also allows learners to reach all the content by using their own electronic devices such as personal computers, smart phones, etc. (Abu-Shanab & Ababneh, 2015). Learners can access the information whenever they want, if they have Internet access and proper device(s).

#### 2.2 Benefits of e-learning

E-learning is a new way to teach that is different from the traditional one (Capper, 2001) and seen as the best method of education in terms of meeting the needs of the learners (Arkorful & Abaidoo, 2015). In e-learning systems, learners are in the center because these systems are designed to answer their needs for performing their work easily

whenever they want, without any time and place restrictions. Thanks to e-learning, people do not have to be physically present at any place and any time (Capper, 2001; Momani et al., 2012; Liaw & Huang, 2013; Arkorful & Abaidoo, 2015). They can reach all educational documents even if they are far away. These documents are always available on e-learning web sites. If learners want to study, they can download or review the contents again and again, whenever they wish. Web sites also offer recorded video about the lectures that is available all the time (Arkorful & Abaidoo, 2015). In short, comparing to traditional learning, learners have more freedom about the accessibility of the related course materials and the access time.

E-learning provides more interaction between learners and instructors, and between learners and learners using communication tools such as e-mail, discussion boards, etc. (Capper, 2001; Liaw & Huang, 2013; Arkorful & Abaidoo, 2015). If learners have questions about the course related to the content or the assignments they can ask via these communication tools. This encourages learners to interact with others. Also, these tools simplify the group works (Capper, 2001). Sometimes, meeting with others is not easy in terms of determining the time and the place. Group members can use online tools to complete their tasks. In this respect, e-learning is cost effective because group members do not have to meet at a specified place to complete the project (Arkorful & Abaidoo, 2015). Moreover, this is also good for disabled learners with mobility difficulties.

### 2.3 Definition of LMS

Learning Management System is software that supports e-learning in terms of designing/managing the learning environment, tracking the learners' performance and

delivering the learning materials (Park, 2009; Mahnegar, 2012). According to Pifia (2013), LMS is an innovation for educational technology that may be a server-based or cloud-based software program with a database storing information about the users, the courses and the content. LMSs can be used without any time and place restriction through a web browser with a computer or an application with a mobile device. Instructors can manage and design the educational environment using the LMS tools for uploading a material, creating an assignment, etc. Also, using the LMS logs, learners' progresses can be tracked by attendance records, time spent on tasks, etc. Learners can reach the content and the materials from the LMS, and also they can communicate with each other. Moreover, the institutions can manage a large number of courses and their users by using LMS interface and its tools.

#### 2.4 Features of LMS

According to Pifia (2013), features of an LMS are divided into categories;

- **Content creation and display tools:** It is an interface for instructors to upload documents, spreadsheets, presentations, images, animations, audio or video into the LMS and create hyperlinks outside the LMS. Also, instructors can create assignments to grade their students and students can upload materials to be graded. Moreover, instructors can design the environment by creating folders and subfolders that are controllable by the instructor.
- **Communication tools:** These tools allow interactions between instructors, students, and the system. They include course announcements, student web pages, e-mail to instructors and class members, threaded discussion boards, wikis, blogs, file sharing,



text chat, whiteboard, and sharable web browser. Also, for team members, LMSs allow creation of an environment that only selected people can write to each other using text chat or threaded discussion, and share files.

- **Assessment tools:** LMSs provide tools for the instructors to create tests, create surveys and track student achievement and activity in the course including number of logins, time spent, and specific areas visited. The instructors can create exams using a generator for creating different types of questions (multiple choice, true/false, essay, short answer, matching, etc.) and create question pools or test banks to store questions that can be used for multiple exams. Instructors can determine which questions can be seen by which students, one-at-a-time or all at once. The instructor can specify the duration of the exam and also instructors can create feedback for the questions. The students can see their exam/assignment grades using the electronic grade book. Anonymous surveys can be used to get feedback from the students.
- **Administrative tools:** By using administrative tools, instructors can manage the settings for the content creation, communication and assessment tools, customize the look of the course, make tools, content and resources available or unavailable to users, manage files and move or copy content. Also, a system administrator can manage the creation of user accounts and courses, enrollment of instructors and students into the courses, enabling and disabling of accounts and courses, and tracking the activity in the system.

In large systems, additional products are needed for additional features such as data analysis, extra storage, etc. According to Pifia (2013), the products to extend the capabilities of LMSs are listed as:

- Learning object repositories: These repositories are additional storage outside of LMSs that enable instructors to manage, edit and link the material(s). Also, they allow students to store their materials that are needed for their papers and projects.
- E-portfolios: These allow students to create their work in a format like a digital resume or curriculum vitae using templates. Also, they allow students to archive their course works to be used in other courses.
- Analytics and outcome assessment: These tools are needed to achieve and improve institutional objectives and standards.

## 2.5 Types of LMSs

LMSs can be divided into two categories as commercial and open source (Pifia, 2013).

According to Henley and Kemp (2008), the Open Source is defined as:

- Free redistribution: software is available for redistribution without payment.
- Source code: software is distributed with the source code or well-publicized access to it.
- Derived works: license to allow the modification of the software and the distribution of derived works.
- Integrity of the author's source code: distribution of "patch files" used to recreate the derived work (rather than full source code) to be permitted.
- No discrimination against persons or groups.

- No discrimination against fields of endeavor; for example, limiting use to non-commercial purposes is not permitted.
- Distribution of license: no need to execute extra licenses for redistributed software.
- License must not be specific to a product: license rights not to depend on the software being distributed with other specified software.
- License must not restrict other software: the license must not place restrictions on software distributed together with the licensed software.
- License must be technology-neutral.

If an LMS has no charge and the source code is open then it is easy to program its code (Henley & Kemp, 2008). However, according to Pifia (2013), open source LMS may require substantial investment in infrastructure including the server hardware and software, server administration, database administration, programming and technical support. For the sake of high quality in open source LMSs, it is needed to take support from the vendor of a commercial system. For example, if you choose Moodle as LMS, you need in-house expertise in MySQL and PHP programming.

According to Pifia (2013), commercial LMSs are more complex, expensive and far from customization. Before public release, these systems are tested in the field whether there is any bug or error, and are guaranteed for customer support and downtime limitations with a warranty. However, open source code carries no customization, guarantee or warranty (Pifia, 2013). Also, Open Source Software (OSS) has large communities and these communities support the software by contributing improvements (Hauge, Ayala, & Conradi, 2010). Thanks to these contributions, the users can rapidly find response to their requests.

According to Brown and Booch (2002), finding security flaws in OSS LMS is practically impossible because large systems can contain millions of lines of code and can be developed by many developers. From security perspective, many companies prefer to use commercial software due to vendor support. Also, there are some strategies to secure the systems listed below when reusing OSS (Brown & Booch, 2002):

1. Don't reuse open source software;
2. Only reuse open-source software that has been through extensive internal code reviews typical of all software developed;
3. Foster a strong relationship and understanding of the open-source software community, closely follow the newsgroups for open-source software that needs to be reused, and get involved in the development of that open source software.

However, according to Fuggetta (2003), in terms of security, safety, and trustworthiness, OSS provides more opportunities than commercial ones acknowledged by the availability of the source code. Moreover, it can have better security level by finding security bug or following the community who use the OSS because people who use the OSS share their experience and solutions on the blogs.

## 2.6 The adoption and implementation of an LMS

According to Black, Beck, Dawson, Jinks, and DiPietro (2007), LMSs software products contain more similarities than differences because they offer same type of tools such as quiz/test options, forums, a scheduling tool, collaborative workspace and grading mechanisms. Although they have more similarities and they are standardized, the adoption of them is differentiating from each other due to the environmental factors that are addressed in Rogers' theory of innovation diffusion (2003). These are five

outstanding attributes that increase the likelihood of LMS adoption and implementation (Black et al., 2007) and need to be considered (Goncalves & Pedro, 2012):

1. **Compatibility:** refers to “the degree to which an innovation is perceived as consistent with the existing values, past experiences, and needs of potential adopters” (Rogers, 2003). If LMSs are not compatible with the current culture, the adoption of it is difficult (Black et al., 2007). Thus, if an individual or other decision-making unit continues to use any innovation, they categorize it as relevant to their needs and consistent with their attitudes and beliefs (Goncalves & Pedro, 2012). All in all, the adoption is related to familiarities of innovation.
2. **Relative Advantage:** refers to the superiority of an innovation when compared to its predecessor (Rogers, 2003). A person chooses an innovation to use if s/he thinks that it is better, more efficient or more effective than any other innovation (Goncalves & Pedro, 2012). According to Black et al. (2007), cost is another factor to be chosen. Additionally, the price of an innovation can differ from others in the same category and if it is more expensive, the benefits of the technology will be negated.
3. **Trialability:** refers to “the degree to which an innovation can be tried on a limited basis before full scale adoption” (Rogers, 2003). For the good of adoption, all users (support staff, instructors, learners) should try to use the new technology on a trial basis and this will save cost, logistics, training and time (Black et al., 2007). Also, if instructors use the system in a blended environment, it will be useful for future usage.
4. **Observability:** refers to “the degree to which the successes and failures of an innovation are visible to others” (Rogers, 2003). According to Goncalves and Pedro (2012), it refers to “the degree to which the benefits of an innovation are visible,

meaningful and measurable”. In the development process, if developers are in close contact with users and give opportunity to use on a trial basis, the adoption process will work better (Black et al., 2007). Also, decreasing/solving user problems are related to increase adoption.

5. Complexity: refers to “the degree to which an innovation is perceived as difficult to understand and to use” (Goncalves & Pedro, 2012). The more simple the usage and implementation of an innovation is, the more easily the adoption is (Rogers, 2003). Implementing a system may require many resources and if the institutions hesitate to support these needs, the adoption will be failure (Black et al., 2007).

In the light of this information, the institutions can successfully implement the LMS and the users can easily adopt it. However, Goncalves and Pedro (2012) state that time is an important factor to adopt any system and the ideal time for educational institutions is between two-three to five years for a full adoption and the establishment of new habits and routines. According to Rogers’s theory (2013), the adoption distribution is similar to Gaussian distribution, and Goncalves and Pedro (2012) observe this distribution by analyzing the data of three academic years containing the number of faculty and students, and the usage rate of them. Mostly faculty members or teachers affect the adoption process (Alias & Zainuddin, 2005; Gautreau, 2011) and Gautreau’s (2011) findings supported prior research and showed that a relationship exists between motivating factors of faculty members (salary, responsibility, achievement, advancement, company policy, the work itself, and recognition) and the adoption of a LMS. Thus, determining faculty needs and meeting them are more important for the adoption because support is the most important factor (Alias & Zainuddin, 2005).

For the perspective of the students, the adoption is determined by organizational factors such as instructor status related with the usage of LMS in courses and course discipline related with teaching style (Naveh, Tubin, & Pliskin, 2010).

Finally, to find users' behavior toward the adoption of any system TAM, e-TAM and derived models are used.

## 2.7 General view of TAM

One of the well-known models related to technology acceptance and use is the technology acceptance model, originally proposed by Davis in 1986, 1989 and 1993 derived from Ajzen's Theory of Reasoned Action (TRA) which is a very general theory to predict and explain any human behavior across a wide variety of domains. Also, in technological projects, TAM should be used to have successful system implementations (Vankatesh & Davis, 1996). The original TAM model is shown in Figure 1.

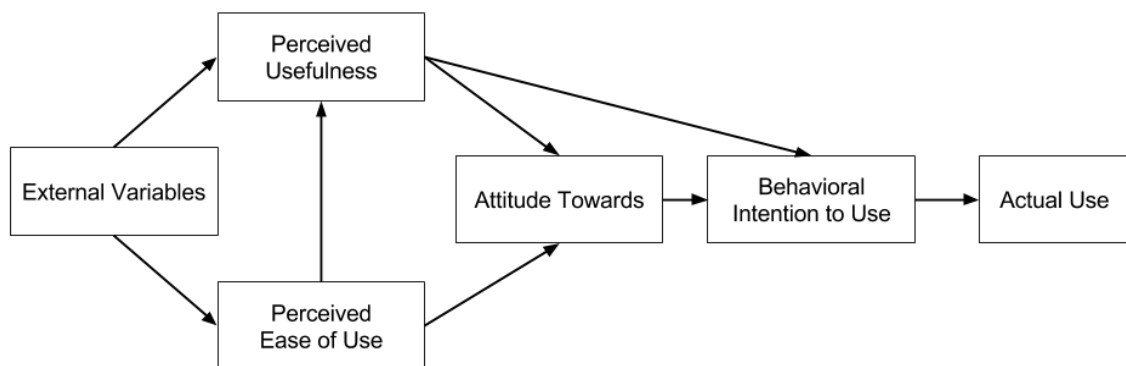

Figure 1. Original technology acceptance model (TAM) (Davis, 1986)

Davis, Bagozzi and Warshaw (1989) found out that attitude and behavioral intention link becomes non-significant and perceived usefulness and perceived ease of use were the key factors for predicting and explaining the user behavior. Also, Davis (1989) conducted a study without attitude and stated the reason by referring Davis (1986) and Davis et al. (1989) that attitudes do not fully mediate the effect of perceived usefulness and perceived ease of use on behavior. Davis (1993) found that perceived usefulness has more direct influence than attitude towards on usage but he finds significant effect between attitude-perceived usefulness, attitude-perceived ease of use, and attitude-usage. Venkatesh and Davis (1996) studied without attitude and found perceived ease of use and usefulness as the key variables.

Since its development, the TAM has been used as a research framework with external variables in many studies in a variety of contexts such as social networks, e-shopping, online games, healthcare, etc. (Davis, 1993; Karahanna, Agarwal, & Angst, 2006; Tarhini et al., 2014, Bajaj & Nidumolu, 1998; Teo, Ursavas, & Bahcekapili, 2012).

Bajaj and Nidumolu (1998) used TAM model by extending it and tried to find the acceptance of a debugger (DBG) system. The model of their research is shown in Figure 2. They hypothesized and found that attitude positively affects usage, usefulness does not positively affect usage, past usage positively affects ease of use, ease of use does not positively affect usefulness, ease of use positively affects attitude, and whether usefulness positively affects attitude or not is contrary. This contrary condition was explained that if it was mentioned to the users that DBG was useful, they had a positive attitude towards using it and if not, they had a negative attitude. They have limitations about the training time and giving positive information about DBG.



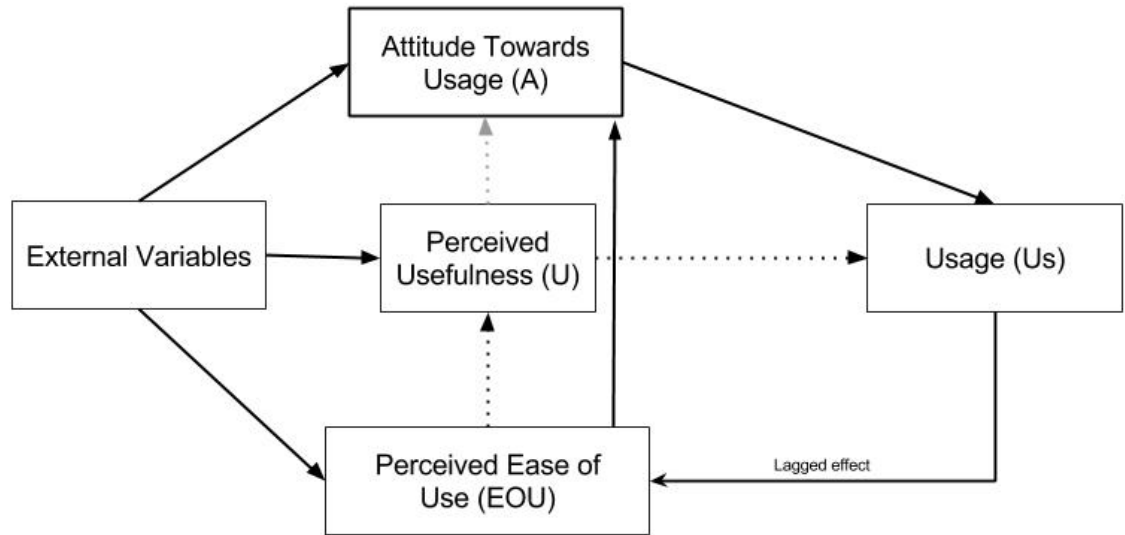

Figure 2. Bajaj and Nidumolu (1998) e-TAM

Karahanna et al. (2006) tried to find the acceptance of CRM and developed their framework by using original TAM and extended variables which were usage, compatibility with preferred work style, compatibility with existing work practices, compatibility with prior experience, and compatibility with values. The model of their research is shown in Figure 3. They found that:

- Ease of use, usefulness, and compatibility with prior experience have positive influence on usage.
- Ease of use, compatibility with prior experience, compatibility with existing work practice and compatibility with values have positive influence on usefulness.
- Compatibility with prior experience, and compatibility with existing work practice have positive influence on ease of use.
- Compatibility with prior experience, compatibility with existing work practice and compatibility with values have positive influence on perceived usefulness.

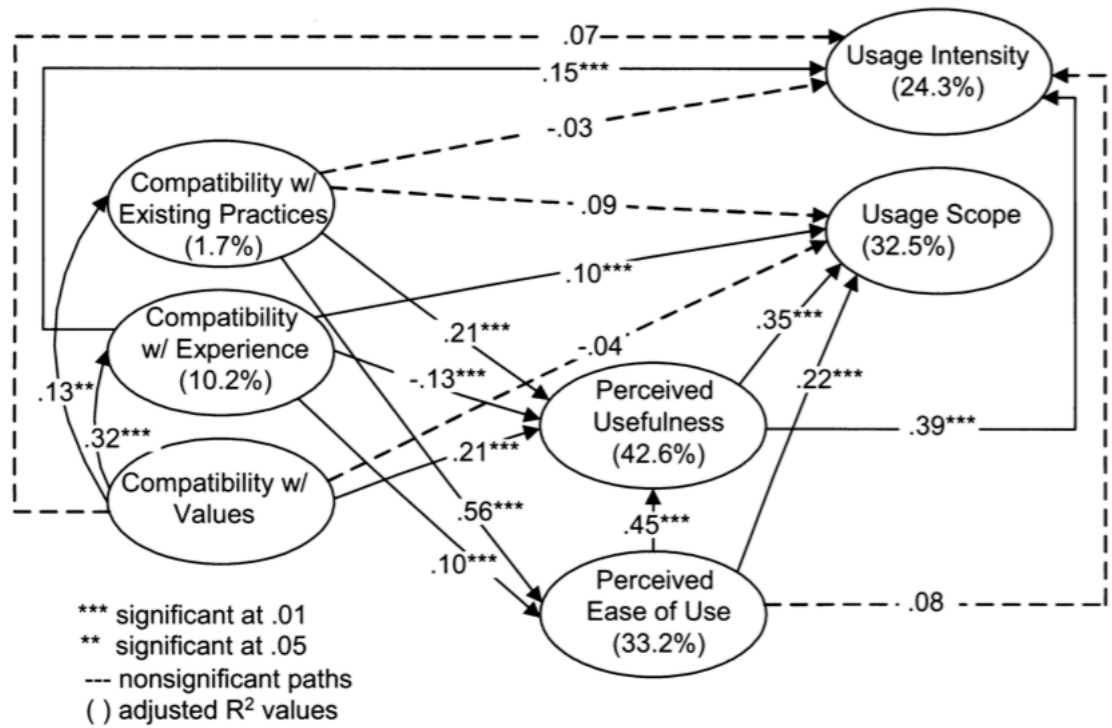

Figure 3. Karahanna et al. (2006) e-TAM

They suggested investigating conditions that influence the relative salience and relationships among compatibility beliefs for future research and also the effect of the social context and moderating effects of age, gender, experience, and voluntariness.

Sanchez and Hueros (2010) used TAM to investigate motivational factors that influence the acceptance of Moodle by including technical support and computer self-efficacy. Also, they used SEM analysis to test their hypotheses. The model of their research is shown in Figure 4. In their study, technical support had a positive effect on perceived ease of use and perceived usefulness of Moodle but had a negative effect on computer self- efficacy towards using Moodle and on attitude towards the use of Moodle. Computer self-efficacy did not have a positive effect on perceived ease of use and perceived usefulness. Perceived ease of use and perceived usefulness had a positive

effect on attitude towards use of Moodle but computer self-efficacy did not. Perceived ease of use had a positive effect on perceived usefulness and use of Moodle. Attitude towards using Moodle had a positive effect on the use of Moodle but perceived usefulness had not. Finally, like other researchers, Sanchez and Hueros (2010) suggested to explore other variables that might affect the usage of the Moodle system. These variables were specified as teacher support for the students, peer support, system accessibility, system appearance, etc.

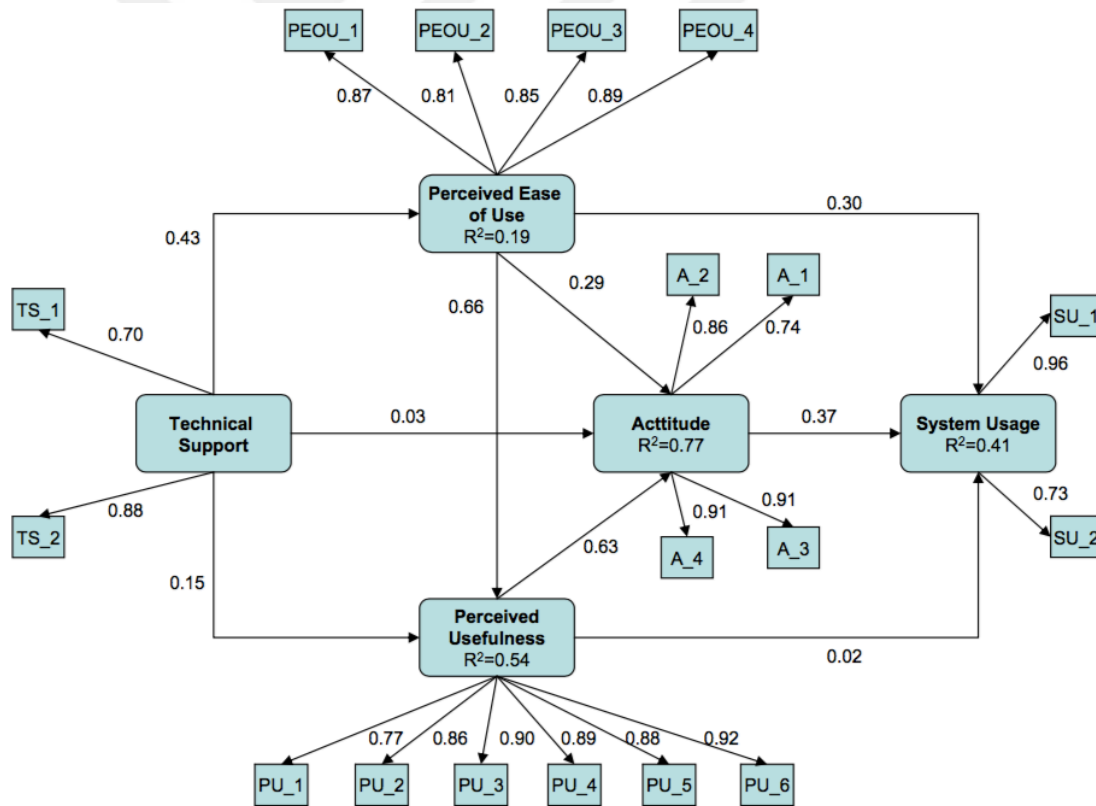

Figure 4. Sanchez and Hueros (2010) e-TAM

Liu, Chen, Sun, Wible, and Kuo (2010) used e-TAM model to explore the factors that affect intention to use Intelligent Web-based Interactive Language Learning (IWILL) community as an online English learning platform for high school students. The model of their research is shown in Figure 5.

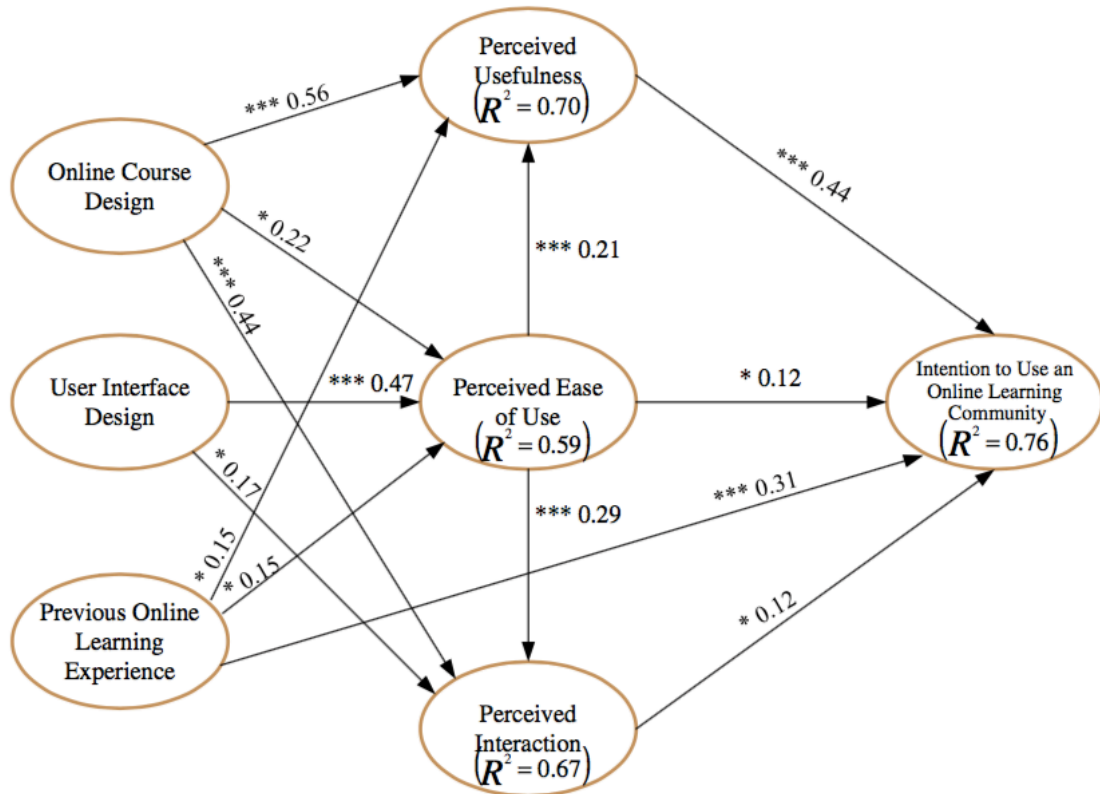

Figure 5. Liu et al. (2010) e-TAM

According to their study, online course design had a significant positive effect on perceived usefulness, perceived ease of use and perceived interaction. User-interface design had a significant positive effect on perceived ease of use and perceived interaction. Previous online learning experience had a significant positive effect on perceived usefulness, perceived ease of use and intention to use an online learning

community. Perceived ease of use had a significant positive effect on perceived usefulness and perceived interaction. Finally, perceived usefulness, perceived ease of use, and perceived interaction had a significant effect on intention to use an online learning community. In their study, the most powerful variable, which was affected intention to use an online learning community, was perceived usefulness and secondly previous online learning experience.

There are some limitations and advices given by Liu et al. (2010). The first one is that the sample contained mostly high school students. In other words, there were very few students who had graduated from high school. They advised for future research to seek ways to get responses from graduated students. The second limitation was lack of demographic data analysis due to improper categorization. They stated that the data should be divided into categories such as gender, age, educational background, as well as current class. The third one is getting data from the database about the number of logins, the number of learning hours, the frequency of interacting with others, and the learning scores from the user profiles. The last one is to encourage the learners by the teachers about participating the online learning system. According to Liu et al. (2010), finding the factors that motivate the students to use the system is so important and should be part of future research.

Escobar-Rodriguez and Monge-Lozano (2012) analyzed students' intention to use Moodle platforms to improve the teaching-learning process using TAM. The model of their research is shown in Figure 6. They extend the TAM model by using perceived usefulness for professors, perceived compatibility with student tasks, and training.

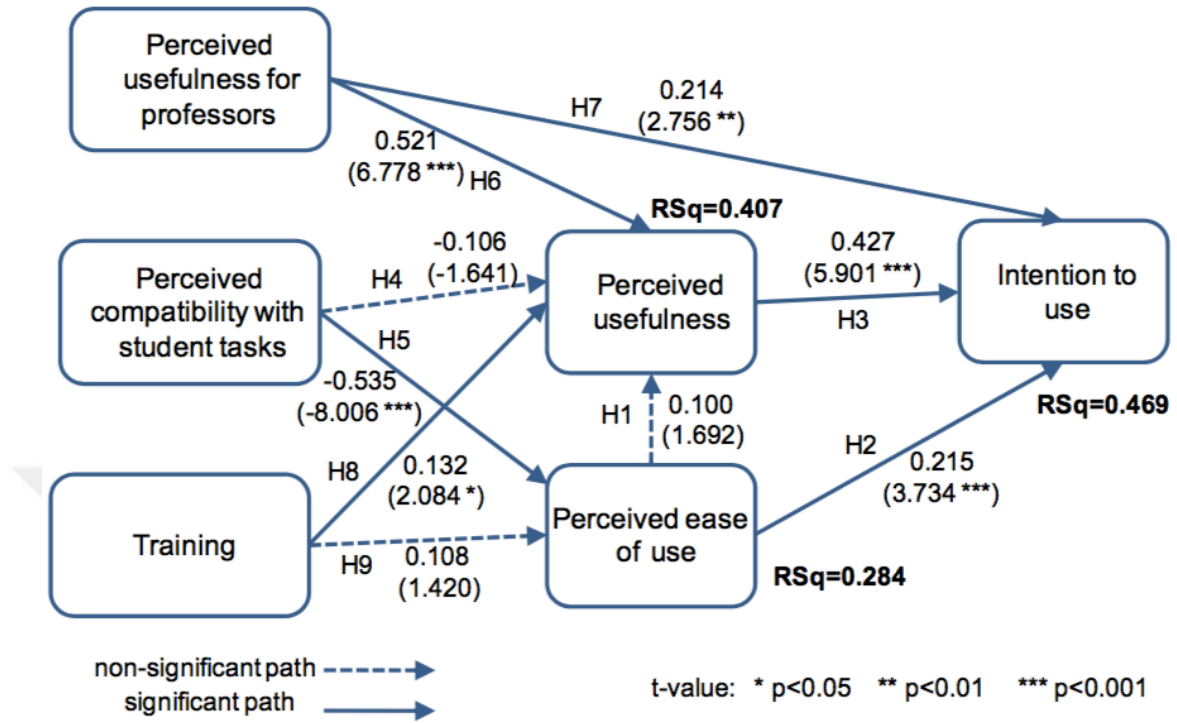

Figure 6. Escobar-Rodriguez and Monge-Lozano (2012) e-TAM

According to Escobar-Rodriguez and Monge-Lozano's research (2012), perceived usefulness for professors, perceived ease of use and perceived usefulness had a significant effect on intention to use Moodle. Perceived compatibility with student tasks had a significant effect on perceived ease of use but not on perceived usefulness. Training and perceived usefulness for professors had a significant effect on perceived usefulness but training did not have any effect on perceived ease of use. Finally, they advised for future research to extend models of technology acceptance to encompass other important theoretical constructs in education.

Iglesias-Pradas, Hernandez-Garcia, and Fernandez-Cardador (2014) used e-TAM to find factors that affect adoption of corporate blogs. The model of their research is shown in Figure 7. According to their findings:

- Perceived usefulness had a significant effect on behavioral intention to use corporate blogs.
- Social presence had a significant effect on perceived ease of use and perceived usefulness.
- Values had a significant effect on preferred work style, prior experience, existing work practice, and perceived usefulness.
- Preferred work style had a significant effect on existing work practice.

In that study, they chose the employees of a department as a sample from a multinational industrial company in Spain. They advised for future research that the sample must be chosen from different departments. They indicated that collecting data using self-reported questionnaires may result in common method bias and common variance tests should be used for further generalization. Finally, they stated that there were some unexpected differences between current work practices, and preferred work style.

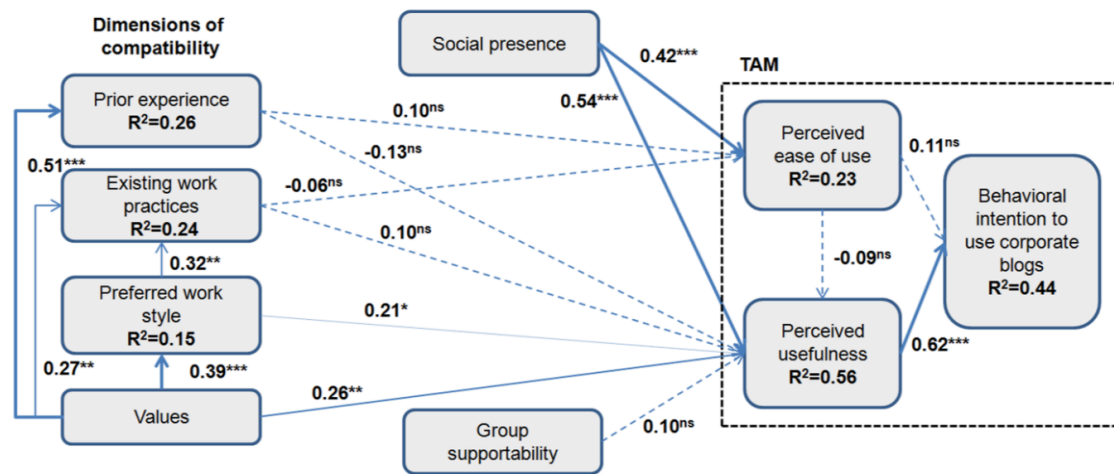

\*p<.05; \*\*p<.01; \*\*\*p<.001 (one-tailed)

Figure 7. Iglesias-Pradas et al. (2014) e-TAM

Tarhini et al. (2013) aimed to study on empirical validation of an e-TAM (included social norms and quality of work life constructs) in the Lebanese web-based learning system by analyzing their data using SEM technique in conjunction with multi-group analysis. The model of their research is shown in Figure 8. All their variables, perceived ease of use, perceived usefulness, social norm, and quality of work life construct, had a significant effect on behavioral intention to use. Their study supported the idea that social contexts are more important than technological solution in terms of e-learning implementation.

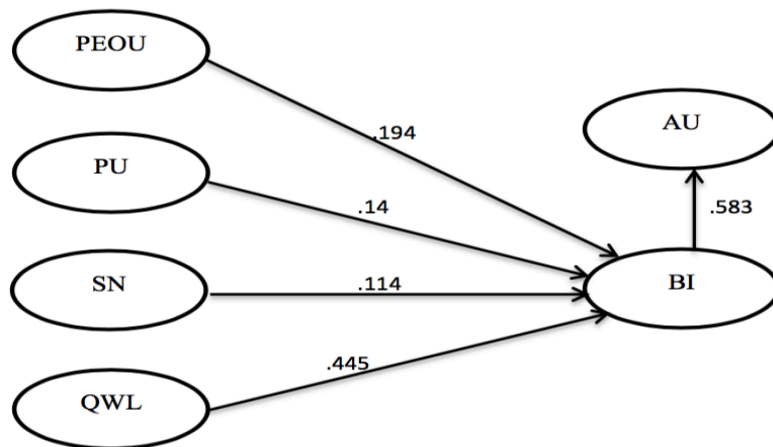

Figure 8. Tarhini et al. (2013) e-TAM

Tarhini et al. (2014) aimed to investigate the factors affecting students' behavioral intention to adopt e-learning technology and to explore the moderating effect of age and gender on the relationships among the determinants affecting e-learning acceptance by using e-TAM and they analyze their data by using structural equation modeling (SEM) technique. The model of their research is shown in Figure 9.



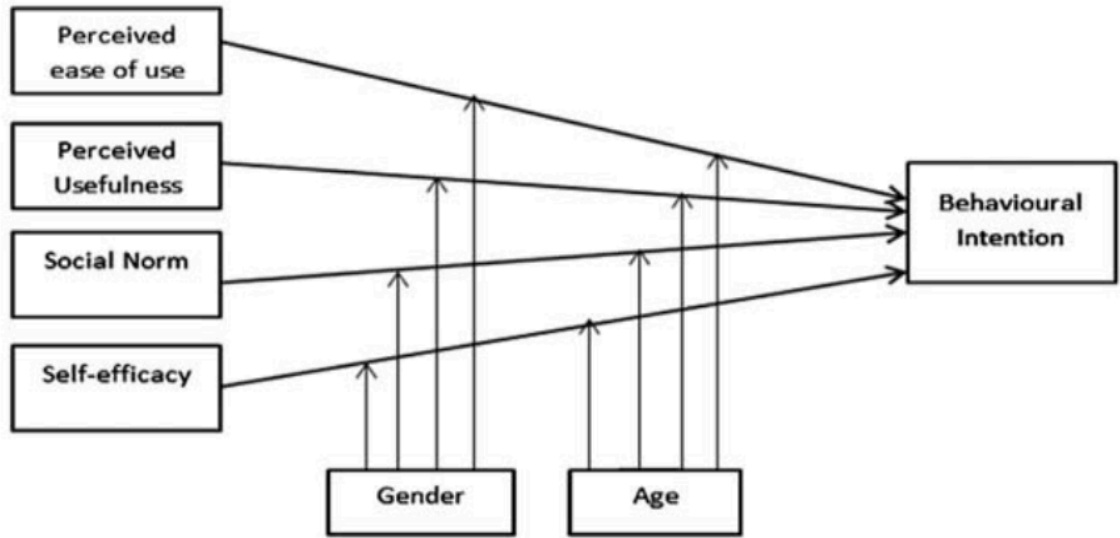

Figure 9. Tarhini et al. (2014) e-TAM

According to their findings, perceived ease of use, perceived usefulness, social norm and self-efficacy had a positive influence on behavioral intention towards using a web-based learning system. Also, age as a moderate variable had a significant effect on determinants (PEOU, PU, SE, and SN) towards behavior intention and gender as a moderating effect on determinants (PEOU, PU, SE, SN) towards behavioral intention. Moreover, they faced some limitations. Firstly, they studied only gender and age, but not other demographic characteristics such as educational level, experience, or culture. Secondly, sampling was an important factor to generalizability and they used a convenience sampling technique and their sample was not representative of the population. Finally, their sample's age range was mostly between 17 and 28, this was not a big generational gap between the two groups in the university but this was representative of students in higher education institutions.

In Ros et al. (2015) study, the aim was to assess the acceptance and the intention to use a third generation LMS in terms of flexibility to build personal learning environments. The model of their research is shown in Figure 10.

According to Ros et al. (2015) findings:

- Gadget design had a significant effect on perceived usefulness and perceived interaction.
- Container design had a significant effect on perceived ease of use.
- Previous experience had a significant effect on perceived ease of use.
- Perceived ease of use had a significant effect on perceived usefulness and perceived interaction.
- Perceived usefulness and perceived interaction had a significant effect on intention to use.

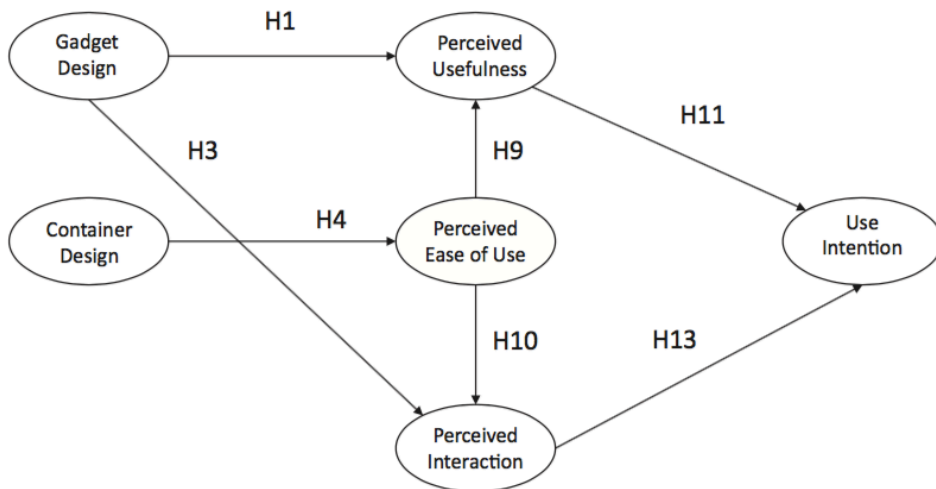
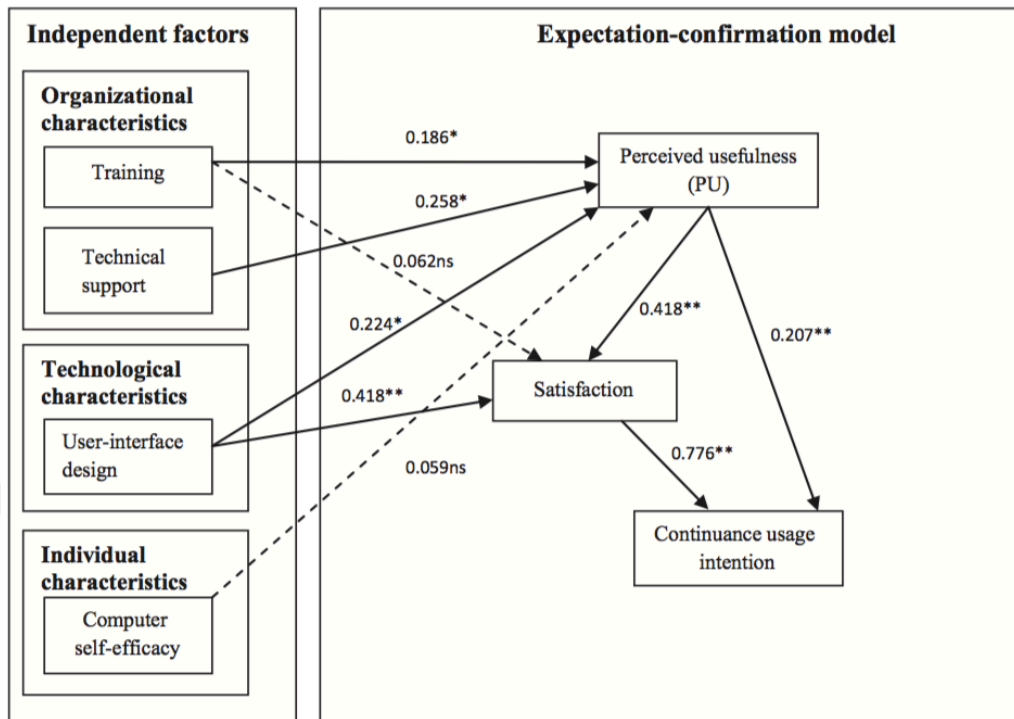

Figure 10. Ros et al. (2015) e-TAM

Ros et al. (2015) faced some limitations. Firstly, it was necessary to distinguish different factors to find the use intention of third-generation LMSs. Secondly, sample was important in terms of size and type. Their sample size was moderate and their sample composed of only students of computer science department. They advised for further research to select large and different type of samples. Thirdly, the design of the questionnaire was very important that each component of the study should be analyzed. Thus, in this study, gadgets were used as a component and each gadget should have been analyzed separately or multimethod measurement could be used. Finally, conducting a study by determining learning styles or models was another important factor to determine the use intention.

Mouakket and Bettayeb (2015) conducted a research to find the factors affecting the university instructors' continuance intention to use LMSs, specifically the Blackboard system. The model of their research is shown in Figure 11. According to their findings, training, technical support and user interface design had a significant effect on perceived usefulness. Perceived usefulness and user interface design had a significant effect on satisfaction. Also, satisfaction and perceived usefulness had a significant effect on continuance usage intention of the Blackboard system.



Notes: \* $p < 0.05$ ; \*\* $p < 0.001$ ; ns = not significant

Figure 11. Mouakket and Bettayeb (2015) study model

Mouakket and Bettayeb (2015) faced some limitations. Firstly, only Blackboard is used to find the factors affecting intention to use LMSs but further research should focus on other LMSs. Secondly, the sample in the study used Blackboard voluntarily not mandatorily. Thus, the further research can choose the sample that uses Blackboard system as mandatory. Thirdly, the other factors could be researched such as computer anxiety and subjective norms, and also, the role of individual differences, such as gender and personality traits on user's continuance intention towards LMS can be taken into account for future research. Finally, their research study used the influence of critical factors about the individual, organizational and technological characteristics on the expectation-confirmation model (ECM). The influence of other characteristics can be taken into account for future research such as environmental characteristics.

Abdullah and Ward (2016) developed a general e-TAM for e-learning (GETAMEL) by analyzing 107 papers covering last ten years. They analyzed the e-learning adoption studies with e-TAM for the last ten years and found that the most commonly used external factors were self-efficacy, social norm, enjoyment, computer anxiety, and experience. They proposed a general extended TAM shown in Figure 12.

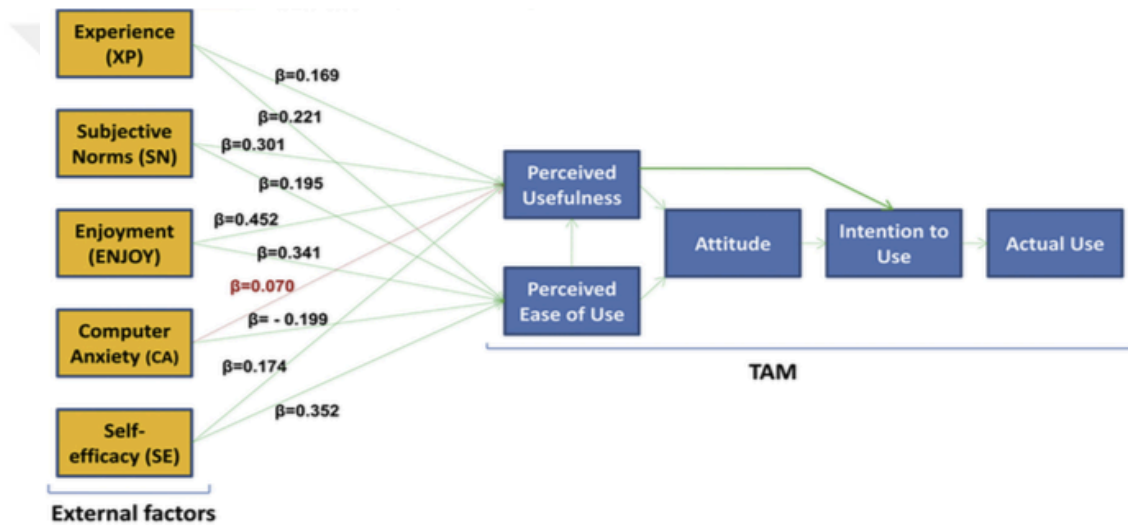

Figure 12. Abdullah and Ward (2016) e-TAM

They determined these factors according to the strength of the relationships between the commonly used external factors and students' perceived ease of use and perceived usefulness. However, they said that technology in e-learning field has changed so fast in the past ten years and so; the findings should be used with caution. Finally, they advised for future research to find the other factors that influence learners' behavior to use any e-learning system.

Yucel and Gulbahar (2013) analyzed fifty papers about TAM between the years 1999 and 2010. The aim of examining these papers were to investigate TAM variables that were found effective and ineffective from a critical point of view, to highlight the top use of the effective variables and to compose the study fields of TAM. They found perceived usefulness, perceived ease of use, intention, investigation of system and tools and technological competency as top variables. Also, they found anxiety, organizational effects, satisfaction, perceived enjoyment and demographic characteristics as the five least used variables. Moreover, analyzed papers were mainly in the field of education and business. Yucel and Gulbahar (2013) used keywords as “Technology Acceptance Model (TAM)” and publication years between 1999 and 2010 to analyze the papers and they had seen these as a limitation. They stated that if they chose different date and keywords, they would find different results. Also, the other limitation was the number of articles used in the research. For the future research, it is advised that new predictor variables for new technologies should be explored and other areas where the technology acceptance seems important should be identified.

In Turkey, Kilic (2014) conducted a research similar to Sanchez and Hueros (2010) and Escobar-Rodriguez and Monge-Lozano (2012) to investigate the factors, which might affect the intention to use Moodle by university students using TAM in case of earthquakes. The model of her research is shown in Figure 13. Due to a destructive earthquake in 2011, Moodle was used to deliver the courses’ contents to all of the students and TAM was applied to analyze the effects of this new technique. Kilic (2014) used Sanchez and Hueros’ basic model (2010) but added an extra variable from Escobar-Rodriguez and Monge-Lozano’s model (2012): perceived usefulness for professors. She found that all the hypotheses were significant but perceived usefulness

for professors had no significant effect on perceived usefulness but had a significant effect on intention to use as Escobar-Rodriguez and Monge-Lozano found. She explained the reason why perceived usefulness was not affected by perceived usefulness for professors as the improper use of Moodle tools by instructors. All in all, her research supported that users' acceptance was affected from environmental factors such as earthquake.

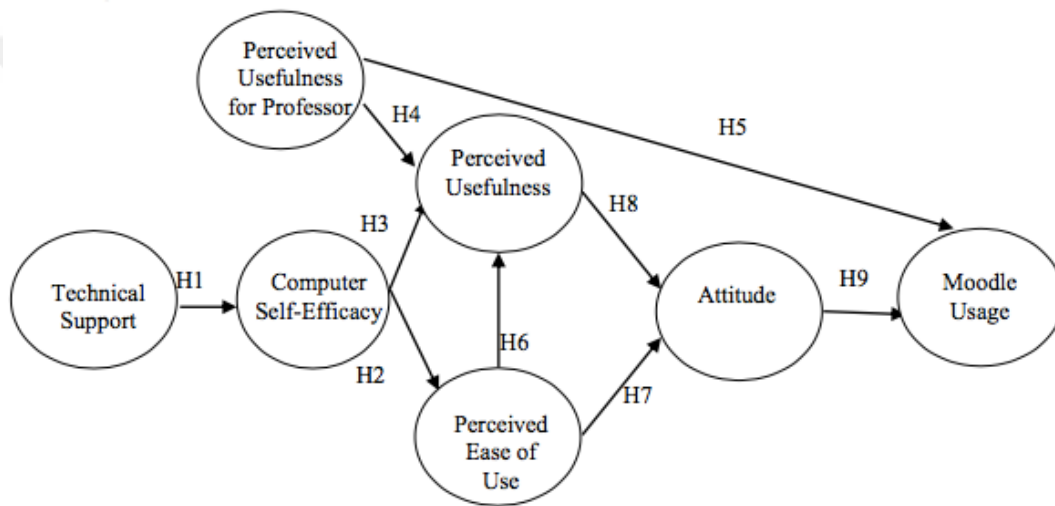

Figure 13. Kilic (2014) e-TAM

Ursavas, Sahin, and McIlroy (2014) made a deeper research and realized that research about teachers' technology acceptance is limited. Their study aim is to develop a valid and reliable scale for explaining teachers' technology uses and acceptance. They used teacher technology acceptance measure (T-TAM) and SEM technique to analyze the data. According to their literature research, many studies about teachers' technology acceptances were related to infrastructural factors such as software, hardware and classroom management but on the contrary, few studies are related to psychological

factors such as computer anxiety, attitudes towards computers and computer self-efficacy.

Finally, Ursavas et al. (2014) developed a valid and robust scale with 37 items under 11 factors: perceived usefulness (4 items), perceived ease of use (3 items), perceived enjoyment (4 items), anxiety (3 items), intention (4 items), compatibility (3 items), technological complexity (3 items), subjective norms (3 items), facilitating conditions (3 items), attitude towards use (4 items), and self-efficacy (3 items). They used original TAM and integrated the new variables to it. They tested the modified TAM with a different sample and provided the explanation of the relationships between factors in the model. However, although their model and scale had high validity and reliability, they advise for further research to test the model with a similar sample. Also, further researcher should use the model for a specific scope to a specific sample and technology.

Acarli and Saglam (2015) used a TAM model that was developed by Davis (1986) and extended by Venkatesh and Davis (1996) to investigate pre-service teachers' intentions to use of social media in teaching activities that becomes indispensable in technologic environments. These pre-service teachers were studying at a university in the faculty of education in Ankara but they were from different regions of Turkey. Also, Acarli and Saglam (2015) used SEM to analyze their data. The model of their research is shown in Figure 14.



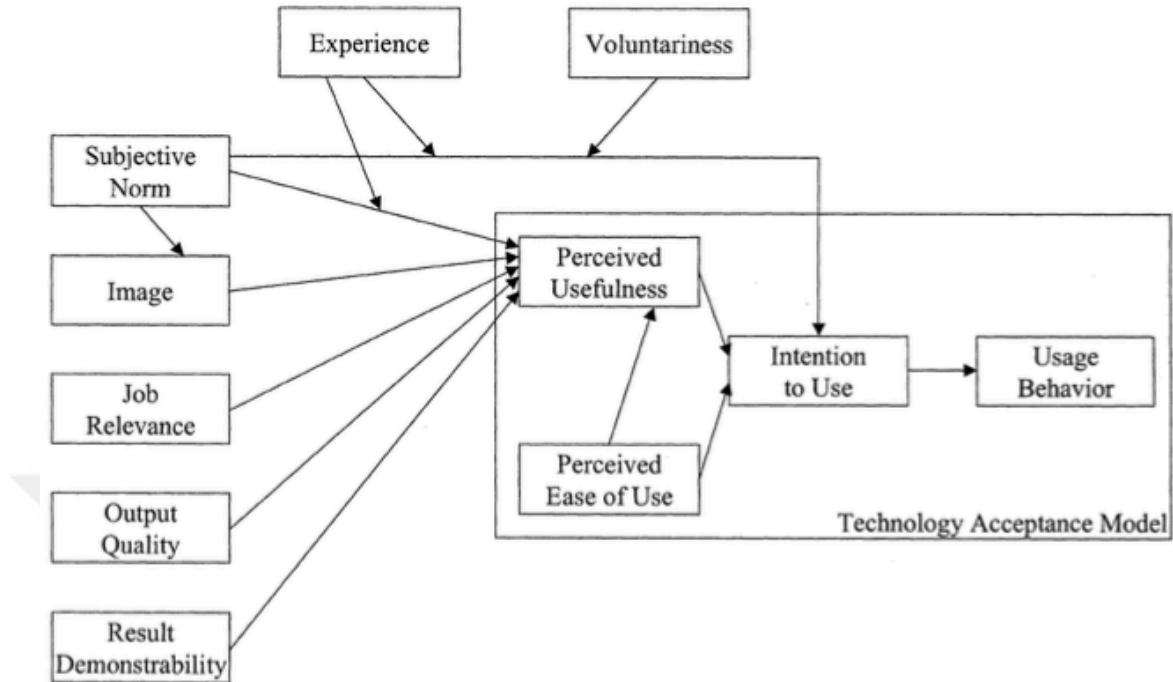

Figure 14. Acarli and Saglam (2015) TAM2

Finally, according to SEM results, Acarli and Saglam (2015) found that their scale used for the study is proper to measure the tendencies of teacher candidates' in terms of usage of the social media in their professional lives. Also, their findings showed that pre-service teachers want to use social media in their professional lives. Moreover, for further research, they had advised applying the developed scale to wider groups.

The aim of Tosuntas, Karadag, and Orhan (2015) was to find the factors affecting high school teachers' acceptance and use of interactive whiteboard within the scope of FATIH project. They used the unified theory of acceptance and use of technology (UTAUT) that is a model of technology acceptance and also they analyzed the findings using SEM technique. The model of their research is shown in Figure 15.

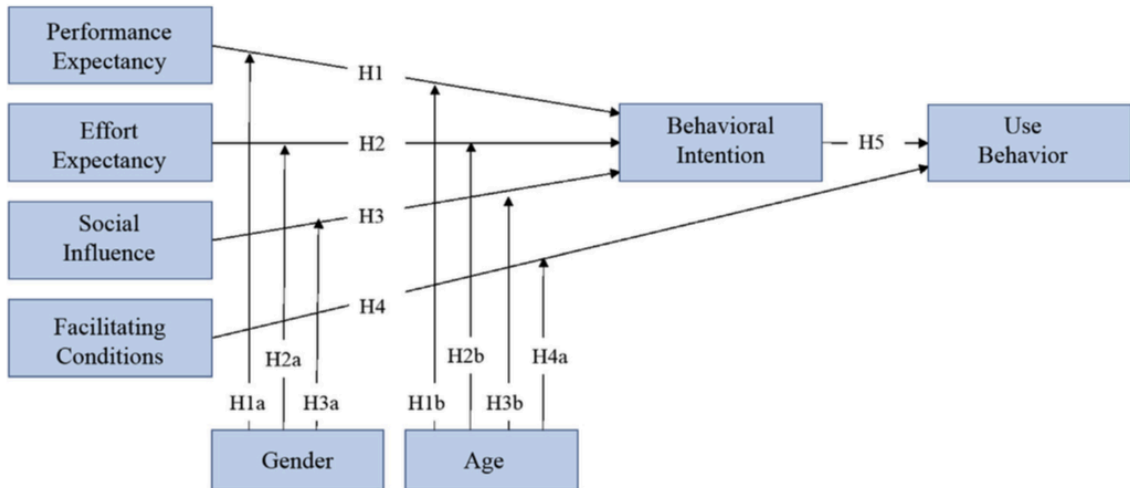

Figure 15. Tosuntas et al. (2015) UTAUT model

According to Tosuntas et al. (2015), the significant findings are listed as:

- Performance expectancy, effort expectancy, social influence and facilitating conditions have a positive effect on behavioral intention regarding the acceptance and use of interactive whiteboards. Also, behavioral intention has a positive effect on the use of interactive whiteboards.
- Effort expectancy affects women's behavioral intention more strongly than men's regarding the acceptance and use of interactive whiteboards.
- Performance expectancy affects behavioral intention more strongly in advanced ages regarding the acceptance and use of interactive whiteboards.
- Effort expectancy affects behavioral intention more strongly in advanced ages regarding the acceptance and use of interactive whiteboards.
- Facilitating conditions affect the use of interactive whiteboards more strongly in advanced ages.

Finally, the stakeholders who want the successful execution of FATIH project can examine the framework of Tosuntas et al.'s study (2015). Similarly, Tosuntas et al.'s study is a guiding study to the researchers to maintain the validity of UTAUT model in the adoption and use of different technologies.

The study conducted by Sezgin and Ozkan-Yildirim (2016) was about finding the factors on pharmacists' acceptance of pharmaceutical service systems. With the help of experts, they developed P-TAM that is composed of TAM, UTAUT and TPB and they used SEM technique for data analysis. The model of their research is shown in Figure 16.

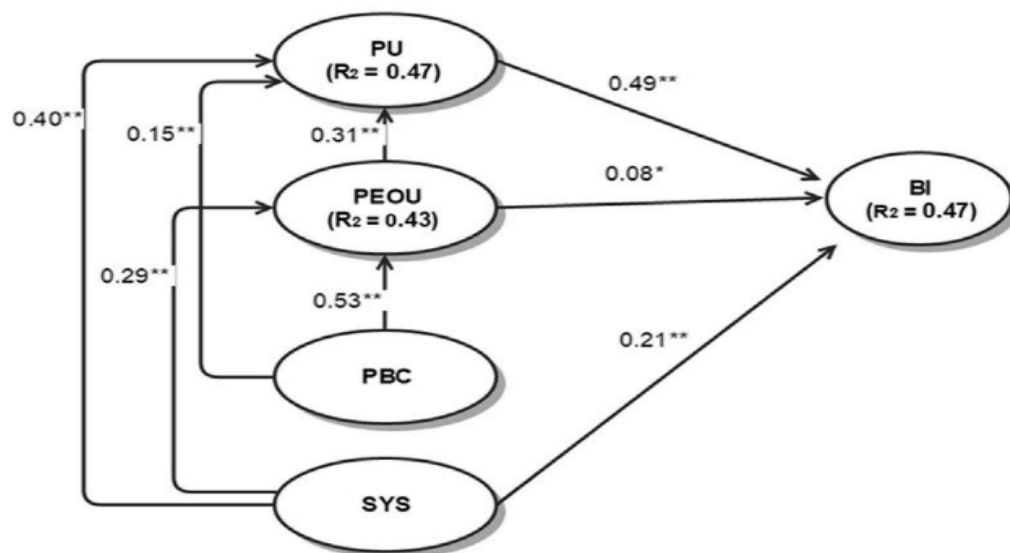

Path coefficients and R<sup>2</sup> values and \*\*P < 0.001, \*P < 0.05

Figure 16. Sezgin and Ozkan-Yildirim (2016) P-TAM

According to the data analysis findings of Sezgin and Ozkan-Yildirim (2016), the significance of factors were listed as:

- Perceived usefulness had a significant influence on behavioral intention.

- System factors had a significant influence on behavioral intention.
- Perceived behavioral control had no significant effect on behavioral intention.
- Perceived ease of use had a significant influence on both perceived usefulness and behavioral intention.
- System factors construct had a significant influence on both perceived usefulness and perceived ease of use.
- Perceived behavioral control had a significant influence on both perceived usefulness and perceived ease of use.

Finally, this study was a first research study applied in Turkey for the assessment of pharmacists' acceptance of a technology. Thus, it is an appropriate tool for system developers and policy makers in pharmaceutical services. For future research, the researchers advised that the model can be expanded by additional factors to get detailed predictions about user intention to use and the sample size can be increased to protect self-selection biases.

Kurfali, Arifoglu, Tokdemir, and Pacin (2017) conducted a research to find factors that effected citizens' decision to use e-government services in Turkey. The model of their research is shown in Figure 17. Their model is UTAUT that is a model of technology acceptance and they use SEM technique for analysis.

According to their findings, trust of Internet, performance expectancy, social influence and facilitating conditions had a significant effect on behavioral intention to use an e-government service. Also, trust of Internet and trust of government had positive influence on the performance expectancy of citizens from e-government services. They took more importance to these results because performance expectancy was the most

influential factor of behavioral intention to use e-government services according to their findings.

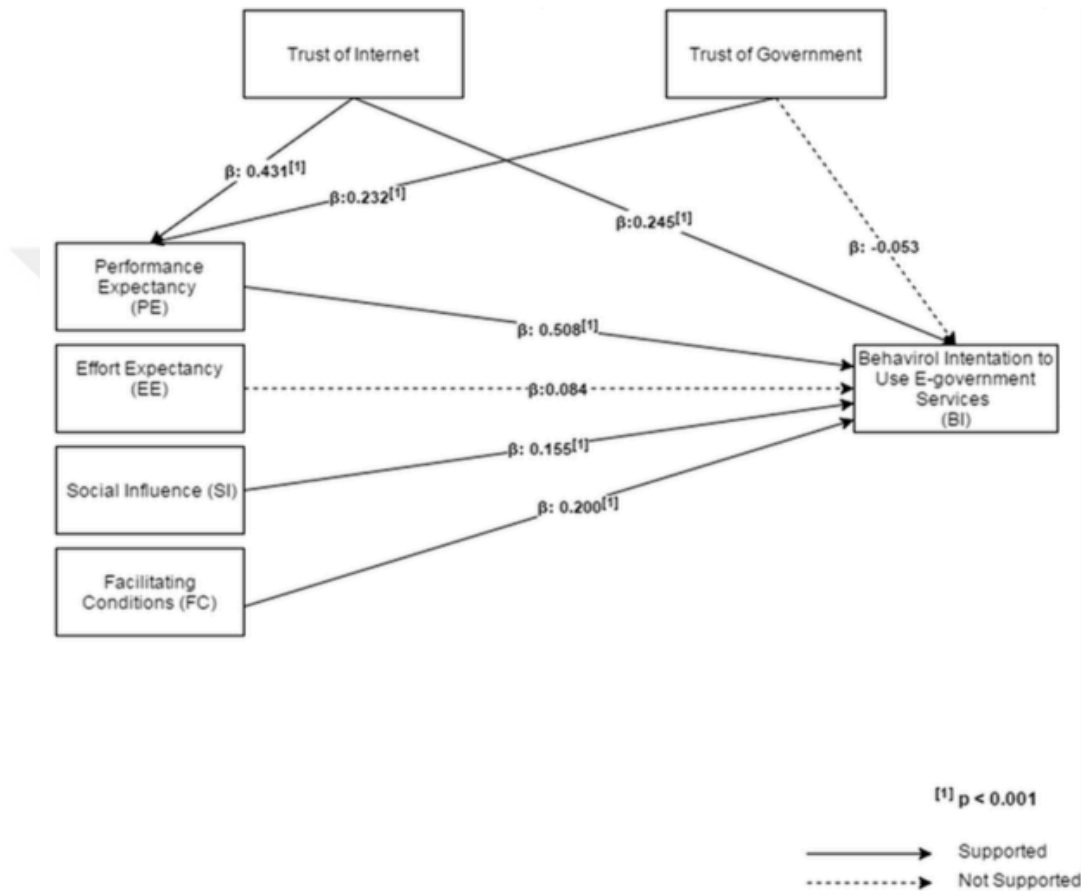

Figure 17. Kurfali et al. (2017) UTAUT model

Finally, Kurfali et al. (2017) did not measure the moderating effects of age, gender and Internet experience due to heterogenous distribution of the data.

Additionally, the distributions of demographic information are not homogeneous such as Internet experience and education level. As a result of this, they advise to increase the number of users. Moreover, Kurfali et al. (2017)'s study covered all e-services provided by the government. According to their findings,  $R^2$  of behavioral intention to use e-

government services was 0.584 that is not so close to 1. Thus, they suggest for further research that one or more additional factors can be added and e-government services can be narrowed down for better understanding of behavioral intention to use e-government services.

In conclusion, TAM has been mostly used in different fields of technology acceptance in the last years and seen as valuable and useful for determination of the factors influencing the intention to use and acceptance of e-learning platforms at universities (Liu et al., 2010; Escobar-Rodriguez & Monge-Lozano, 2012; Kilic, 2014; Ros et al., 2015). However, all studies showed that there are no common models or factors. Almost all studies used different factors, samples or technologies to find the behavioral intention to use. On the contrary to these studies, in this study the most common factors are considered and the model is applied to two different sample groups.

## 2.8 Structural equation modeling (SEM)

Structural Equation Modeling (SEM) has been widely used in so many disciplines to analyze the relationships between latent and observed constructs and especially to analyze the causal links between latent constructs (Reisinger & Turner, 1999).

Byrne (2010) stated that SEM is a statistical methodology that takes a confirmatory (i.e., hypothesis-testing) approach to the analysis of a structural theory bearing on some phenomenon. Moreover, SEM conveys two important aspects of the procedure: a) that the causal processes under study are represented by a series of structural (i.e., regression) equations, and (b) that these structural relations can be modeled pictorially to enable a clearer conceptualization of the theory under study. Also, Cheng's study (2001) revealed that SEM is more effective than multiple regression in

finding the “best fitting” model. Thus, the hypotheses in the study are statistically tested with all variables simultaneously. After analysis with SEM, the researchers check the goodness-of-fit values. If the values are in desired range, the model is appropriate and researchers can check whether the hypotheses are supported or not. However, if the values are not adequate, the hypotheses are rejected.

SEM consists of two variable types as Observed Variable (Measured Variable) and Unobserved Variable (Latent Variable) (Reisinger & Turner, 1999). Observed variable consists of finite number of values such as distance, cost, size, weight or height and is measured and observed from sample through data collection methods, or secondary data collection from a published source. Unobserved variable, is also called latent variable, is not measured or observed directly such as attitudes, customer satisfaction, perception of value or quality and also have an infinite variable compared to observed variable. However, these two variables are usually continuous.

SEM can be analyzed using SPSS AMOS software. Variables are represented by different shapes, such as observed variables by a rectangle or box and unobserved variables by a circle or an oval. An example of SEM is shown in Figure 18.

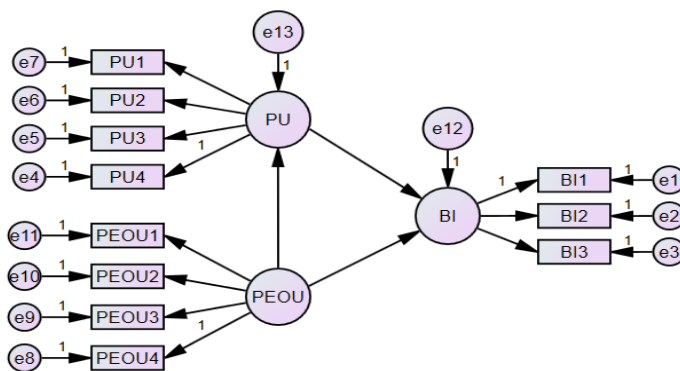

Figure 18. SEM analysis example

## CHAPTER 3

### THEORETICAL FRAMEWORK AND HYPOTHESES

#### 3.1 Theoretical framework

In e-TAM models, there is not any common model because every study chooses different external variables. Therefore, to determine the external variables in the framework, the most common variables are chosen from the literature. The variables used in this study were not used altogether in one framework in other studies. Moreover, this framework will be analyzed by SEM technique that is widely used lately.

A theoretical model for university students' acceptance and intention to use LMSs based on the previous research was developed (Figure 19). The variables that formed this model will be introduced in the following part. This model aims to explain students' acceptance and intention to use learning management systems (LMSs) using extended technology acceptance model (e-TAM). In this study, nine factors are used to define users' acceptance towards the system: Behavioral Intention to Use (BIU), Perceived Usefulness (PU), Perceived Ease of Use (PEOU), Perceived Interaction (PI), Social Norm (SN), and Compatibility with Preferred Work Style (CPWS), User Interface Design (UID), Computer Self-Efficacy (CSE), and Previous Online Learning Experience (POLE).



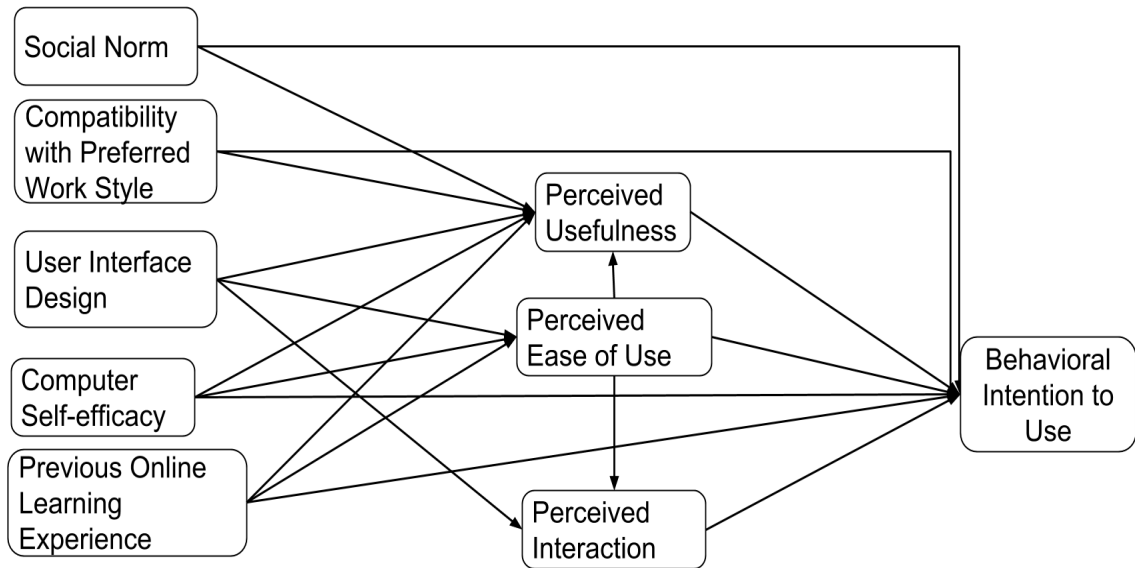

Figure 19. Theoretical framework

## 3.2 Hypotheses

### 3.2.1 Behavioral intention to use

Behavioral intention to Use (BIU) is defined as “a measure of the likelihood that a person will employ the application” (Ajzen & Fishbein, 1980 cited in Lederer, Maupin, Sena, and Zhuang, 2000). BIU is taken as a dependent variable in previous TAM studies (Karahanna et al., 2006; Park, 2009; Sanchez & Hueros, 2010; Escobar-Rodriguez & Monge-Lozano, 2012; Tarhini et al., 2014; Iglesias-Pradas et al., 2014; Kilic, 2014; Ros et al., 2014; Ros et al., 2015; Kurfali et al., 2017).

### 3.2.2 Perceived usefulness

Perceived Usefulness (PU) is defined in general as “the degree to which an individual believes that using a particular system would enhance his or her job performance”

(Davis, 1986, 1989 and 1993; Davis et al., 1989; Venkatesh & Davis, 1996; Bajaj & Nidimolu, 1998; Lederer et al., 2000; Escobar-Rodriguez & Monge-Lozano, 2012; Kilic, 2014; Abu-Shanab & Ababneh, 2015; Chung & Ackerman, 2015). If people believe that technology will provide an advantage and will improve their performance, they continue to use it (Davis, 1989; Liu et al., 2010). Also, according to Sanchez and Hueros (2010), the user has an extrinsic motivation for PU, and is defined as “the degree to which a person believes that the use of a particular system can enhance work performance”.

Karahanna et al. (2006) define PU as “the instrumental value derived from the use of a technology”. PU has a direct effect on BIU and the related hypothesis is formed below:

- H1. Perceived Usefulness will positively affect the Behavioral Intention to Use of a learning management system.

### 3.2.3 Perceived ease of use

Perceived Ease of Use (PEOU) is defined as “the degree to which an individual believes that using a particular system would be free of physical and mental effort” (Davis, 1986, 1989, 1993; Davis et al., 1989; Bajaj & Nidumolu, 1998; Liu et al., 2010; Escobar-Rodriguez & Monge-Lozano, 2012; Chung & Ackerman, 2015). PEOU is also seen as the user’s perception of the amount of effort and time needed to use the system (Venkatesh & Davis, 1996). If people spend a lot of time for a technology and the usage of it is too hard, they think that the system is useless (Davis, 1989; Sanchez & Hueros, 2010; Kilic 2014). Sanchez and Hueros (2010) state that “perceived ease of use, which is the degree to which the user considers that the usage of a particular technology does not require extra effort” and if the perceived complication increases, the perceived ease of use decreases. Thus, people mostly use user-friendly systems and such systems are

mostly successful and easily adopted (Abu-Shanab & Ababneh, 2015). The related hypotheses about PEOU are listed below:

H2. Perceived Ease of Use will positively affect the Perceived Usefulness of a learning management system.

H3. Perceived Ease of Use will positively affect the Perceived Interaction with a learning management system.

H4. Perceived Ease of Use will positively affect the Intention to Use a learning management system.

#### 3.2.4 Perceived interaction

Perceived Interaction (PI) is defined as “the interaction between human-system interaction and interpersonal interaction in the online learning community” (Liu et al., 2010; Ros et al., 2015). Human system interaction is related with the operating environment of the online course; interpersonal interaction occurring between peers and instructors (Liu et al., 2010). LMS usage requires the system participation. Thus, this participation enhances the communication of knowledge and sharing interaction with users in the LMS environment (Liu et al., 2010). Also, the interaction between users, and between learners and instructors, will lead to knowledge construction and knowing each other. Moreover, Sanchez and Hueros (2010) propose for future research to explore teacher support for students and peer support. Hence, PI has a direct effect on BIU and the related hypothesis is listed below:

H5. Perceived Interaction will positively affect the Intention to Use a learning management system.

### 3.2.5 Social norm

Social Norm (SN) is also known as subjective norm and defined as “the person’s perception that most people who are important to him or her think that he or she should or should not perform the behavior in question” (Ajzen and Fishbein, 1980 cited in Tarhini et al., 2013, 2014). SN is such social pressure that affects students’ perception to use LMSs (Liu et al., 2010) and affects students’ perception of perceived usefulness (Park, 2009; Acarli & Saglam, 2015). Abdullah and Ward (2016) analysis of 107 TAM papers covering the last ten years concluded that SN is classified as the most commonly used external factors. SN is presumed to have a direct effect on BIU and the related hypotheses are listed below:

- H6. Social Norm will positively affect student’s Behavioral Intention to Use a learning management system.
- H7. Social Norm will positively affect the Perceived Usefulness of a learning management system.

### 3.2.6 Compatibility with preferred work style

Compatibility with Preferred Work Style (CPWS) is defined as “the perceived cognitive distance between an innovation and precursor methods for accomplishing tasks” (Karahanna et al., 2006). According to Karahanna et al. (2006), the usage of the new technology should not require substantial change in work style for better utilization and high usage rate. Thus, it should be prepared for a proper lecture environment on the online platform and that is consistent with students’ usual work style. Although there are many benefits of e-learning platforms, students may not accept the new technology if it is not compatible with their usual way of work style (Escobar-Rodriguez & Monge-

Lozano, 2012; Ahmed & Ward, 2016). CPWS has a direct effect on BIU and PU related hypotheses are listed below:

H8. Compatibility with Preferred Work Style will positively affect student's Behavioral Intention to Use a learning management system.

H9. Compatibility with Preferred Work Style will positively affect Perceived Usefulness of a learning management system.

### 3.2.7 User interface design

User Interface Design (UID) is related with menu design including control bars, screen design, icons, touch screens, etc. Proper use of UID increases the technology acceptance and the usability (Davis et al., 1989; Mouakket & Bettayeb, 2015). Technological characteristics affect the feeling of the benefits and usefulness of the systems (Mouakket & Bettayeb, 2015). The user-friendlier a system is, the more learners will use it. Thus, if the developers of LMS want to attract their customers, they should design their products more user-friendly and this will make users more comfortable to use the systems (Mouakket & Bettayeb, 2015). UID has a direct effect on BIU, PU, and PEOU and the related hypotheses are listed below:

H10. User-interface Design will positively affect Perceived Usefulness of a learning management system.

H11. User-interface Design will positively affect the Perceived Ease of Use of a learning management system.

H12. User-interface Design will positively affect Perceived Interaction of a learning management system.

### 3.2.8 Computer self-efficacy

Computer Self-Efficacy (CSE) is defined as “a judgment of one’s capability to use a computer and the belief people have in their own ability to cope with the challenges” (Venkatesh & Davis, 1996; Sanchez & Hueros, 2010; Teo et al., 2012; Kilic, 2014; Ahmed & Ward, 2016). CSE has a great influence on technology acceptance because people are more likely to use an innovation when they do something with less effort (Abdullah & Ward, 2016). Thus, CSE is important for students to use technology in their everyday educational practices (Teo et al., 2012). According to Venkatesh and Davis (1996), the reason of rejection or acceptance of systems is the degree of computer self-efficacy. Thus, increasing the level of CSE among the learners leads to improve their acceptance of systems (Mouakket & Bettayeb, 2015). CSE has a direct effect on PU, PEOU and BIU and the following hypotheses were proposed:

H13. Computer Self-efficacy will positively affect Perceived Usefulness of a learning management system.

H14. Computer Self-efficacy will positively affect Perceived Ease of Use of a learning management system.

H15. Computer Self-efficacy will positively affect the Intention to Use a learning management system.

### 3.2.9 Previous online learning experience

Previous Online Learning Experience (POLE) is found as the most commonly used external factors according to Abdullah and Ward’s study (2016). If the utilized technology is compatible with prior experience, the users has lower cognitive burden (Karahanna et al., 2006; Iglesias-Pradas et al., 2014). Thus, using any similar system has

a significant effect on BIU (Ros et al., 2015). Also, the future usage of a system is affected by users' previous usage and POLE should be taken as a factor to determine users' BIU (Liu et al., 2010). POLE is assumed to have a direct effect on PU, PEOU and BIU and the following hypotheses were proposed:

H16. Previous Online Learning Experience will positively affect the Perceived Usefulness of a learning management system.

H17. Previous Online Learning Experience will positively affect the Perceived Ease of Use of a learning management system.

H18. Previous Online Learning Experience will positively affect the Intention to Use a learning management system.

## CHAPTER 4

### METHODOLOGY

#### 4.1 Research design

Firstly, the literature was reviewed and framework was created after which variables will be used was decided. During the questionnaire creation period, two experts, Prof. Dr. Birgül Kutlu Bayraktar and Prof. Dr. Zuhâl Tanrıkulu, chose the items to be used in this study. According to their advice, the items were deleted, added or adapted from original items.

Secondly, data was collected using a convenience sampling method and using an online self-administered questionnaire on Google Form together with hard copies in class. The instructional term that the questionnaire was administered was 2016-2017 Spring. For the data collection, the questionnaire link was shared via social media platforms but the contribution was not noticeable. For this reason in Istanbul Bilgi University, the data were mostly collected using hardcopies and private links sent to the students of assisted class. In Boğaziçi University, the questionnaire link was announced via the university's communication office and then also emailed to the students of the Department of Management Information Systems. Also, e-mail was sent to related instructors so that they can share the link. Hard copies of the questionnaire were administered to the students of related classes after permission was granted. Finally, at south Campus of Boğaziçi University, with the help of personal and family efforts the surveys were filled out.

After the data collection, the analysis period is conducted and hypothesis testing is performed.



#### 4.2 Items in the questionnaire

The questionnaire is composed two parts: the items of demographic information and the items of variables (Appendix A).

The demographic information included university name, department name, educational level, year of study in the university, gender, age, LMS used, LMS experience, Internet and computer experience, number of courses using LMS in previous semester, number of courses using LMS in current semester, and finally usage of LMS per day.

For all items of variables, 5-point Likert scale where 1 is strongly disagree and 5 is strongly agree is used. The items are adapted from literature and shown in Table 1.

#### 4.3 Population and sample

The study is conducted at two different places (Istanbul Bilgi University and Boğaziçi University) because the items in the questionnaire were prepared in English and the language of education in both universities is English:

- Istanbul Bilgi University is chosen because almost all instructors use Moodle and Blackboard. They actively use LMS. Every student is registered automatically to the courses that they take.
- Boğaziçi University is chosen because some departments use Moodle. Students have a password given by the instructors, have to visit web site and register themselves.

Table 1. Sources of Items in the Questionnaire

Name of Construct	Items of Construct	Origin from literature
Behavioral Intention to Use	BIU1, BIU2 and BIU3	Adapted from Tarhini et al. (2014)
Perceived Usefulness	PU1, PU2, PU3, PU4 and PU5	Adapted from Tarhini et al. (2014)
	PU6	Adapted from Ros et al. (2015)
Perceived Ease of Use	PEOU1, PEOU2, PEOU3, PEOU4 and PEOU5	Adapted from Tarhini et al. (2014)
	PEOU6	Adapted from Sanchez & Hueros (2010)
Perceived Interaction	PI1, PI2 and PI3	Adapted from Liu et al. (2010)
Previous Online Learning Experience	POLE1, POLE2 and POLE3	Adapted from Ros et al. (2015)
	POLE4	Adapted from Liu et al. (2010)
User Interface Design	UID1, UID2 and UID3	Adapted from Mouakket & Bettayeb (2015)
	UID4	Adapted from Liu et al. (2010)
Social Norm	SN1 and SN2	Adapted from Tarhini et al. (2014)
	SN3	Self-developed
Compatibility with Preferred Work Style	CPWS1 and CPWS2	Adapted from Ahmed & Ward (2016)
	CPWS3	Adapted from Escobar-Rodriguez & Monge-Lozano (2012)
Computer Self-Efficacy	CSE1, CSE2, CSE3, CSE4, CSE5 and CSE6	Adapted from Sanchez & Hueros (2010)

Finally, it is paid attention to choose samples according to the adoption issues (explained in Chapter 2). Especially in Boğaziçi University, LMS was not used effectively in some courses. Their instructors inform and warn about LMS usage. Thus, the data is not gathered from these courses. However, how much the students took courses with LMS in new term is listed below:

- The percentage of taking 1-2 courses is
  - 6.25 in Bilgi University,

- 49.18 in Boğaziçi University,
- The percentage of taking 3-4 courses is
  - 13.75 in Bilgi University,
  - 32.79 in Boğaziçi University,
- The percentage of taking 5-6 courses is
  - 40.63 in Bilgi University,
  - 10.66 in Boğaziçi University,
- The percentage of taking 7 or more courses is
  - 39.37 in Bilgi University,
  - 7.38 in Boğaziçi University,

Also, the percentages about taking courses with LMS in previous academic year are almost similar to listed values.

#### 4.4 Data analysis tools

The data obtained from the questionnaires were transferred to Excel and then transferred to Statistical Package for Social Sciences (SPSS) Version 20 and SPSS Amos 23 for SEM analysis.

CHAPTER 5  
ANALYSIS AND FINDINGS

5.1 Descriptive findings

The total sample of the study is 282. 43.3% of them are female and 56.7% of them are male (Table 2).

Table 2. The Female-Male Rate that are Included in This Study

University Name	Female	Male	Total
Boğaziçi University	51	71	122
Istanbul Bilgi University	71	89	160
Total	122	160	282
	43.3%	56.7%	

According to Table 3, 1% of the students are in preparation class, 10% of them are first year, 27% of them are second year, 32% of them are third year, and 31% of them are fourth year or more.

Table 3. Year in the University

University Name	Preparation Year Freq. (%)	First Year Freq. (%)	Second Year Freq. (%)	Third Year Freq. (%)	Four or more Years Freq. (%)
Boğaziçi University	2 (2%)	22 (18%)	36 (30%)	23 (19%)	39 (32%)
Istanbul Bilgi University	0 (0%)	5 (3%)	40 (26%)	60 (39%)	49 (32%)
Total	2 (1%)	27 (10%)	76 (27%)	89 (32%)	88 (31%)

Finally, the departments of the students are shown in Table 4.

Table 4. The Departments Included in This Study

	Number of Participants
Chemical Engineering	4
Civil Engineering	1
Computer Education and Educational Technology	6
Computer Engineering	31
Computer Science	1
Economics	1
Foreign Language Education	2
History	1
Industrial Engineering	22
International Trade	4
Management	7
Management Information Systems	10
Mechanical Engineering	1
Physics teaching	1
Physics	2
Political Science	2
Psychology	6
Science education	1
Tourism Administration	4
Translation and Interpreting Studies	1
Turkish Language and Literature	6
Undergraduate Mathematics Education	5
Western Language and Literature	3
<b>Total Boğaziçi University</b>	<b>122</b>
Banking and Finance	7
Business Administration	72
Business Informatics	27
Business-Economics	9
Civil Engineering	1
Economics	1
Industrial Engineering	2
International Finance	3
International Relations	1
International Trade and Business	35
International Retail Management	1
Psychology	1
<b>Total Istanbul Bilgi University</b>	<b>160</b>
<b>General Total</b>	<b>282</b>

Descriptive statistics about participants are shown in Table 2. As can be seen from Table 2, 43.3% of students are female and 56.7% of them are male. For Boğaziçi University, 61% of them are undergraduate, 24% of them are MA and 15% of them are PHD students where for Istanbul Bilgi University, 98% of them are undergraduate and 2% of them are PHD students. Most of the participants are 21-23 years old.

Table 5. Descriptive Analysis of the Age of Sample

University Name		18-20	21-23	24-26	27-29	29<
Boğaziçi University	Freq. (%)	25 (20%)	58 (48%)	23 (19%)	7 (6%)	9 (7%)
Istanbul Bilgi University	Freq. (%)	27 (17%)	105 (66%)	22 (14%)	4 (2%)	2 (1%)
Total	Freq. (%)	52 (18%)	163 (58%)	45 (16%)	11 (4%)	11 (4%)

As shown in Table 6, 69% of the participants use LMS more than 1 hour per day, 24% of them use 1-2 hours, 6% of them use 3-4 hours, and only 1% of them use more than 5 hours. Also, in general, 29% of the students use LMS always, 32% of them use often, 28% of them use sometimes and 10% of them use rarely. Finally, 61% of the students use Internet and Computer always, where 26% of them use often.

Table 6. LMS Experience per Day, LMS Experience and Internet and Computer Experience

LMS Experience per day (hour)						
		>1	1-2	3-4	5-6	6<
Boğaziçi University	Freq. (%)	102 (83%)	18 (15%)	1 (1%)	1 (1%)	0 (0%)
Istanbul Bilgi University	Freq. (%)	92 (57%)	49 (31%)	16 (10%)	2 (1%)	1 (1%)
Total	Freq. (%)	194 (69%)	67 (24%)	17 (6%)	3 (0.9%)	1 (0.1%)
LMS Experience						
		Never	Rarely	Sometimes	Always	Often
Boğaziçi University	Freq. (%)	1 (1%)	16 (13%)	47 (39%)	25 (20%)	33 (27%)
Istanbul Bilgi University	Freq. (%)	3 (2%)	11 (6%)	31 (19%)	57 (36%)	58 (36%)
Total	Freq. (%)	4 (1%)	27 (10%)	78 (28%)	82 (29%)	91 (32%)
Internet and Computer Experience						
		Never	Rarely	Sometimes	Always	Often
Boğaziçi University	Freq. (%)	2 (2%)	3 (2%)	8 (6%)	81 (65%)	30 (24%)
Istanbul Bilgi University	Freq. (%)	0 (0%)	9 (6%)	15 (9%)	90 (57%)	44 (28%)
Total	Freq. (%)	2 (1%)	12 (4%)	23 (8%)	171 (61%)	74 (26%)

### 5.1.1 Descriptive statistics for behavioral intention to use LMS

This part of the questionnaire attempts to measure respondents' behavioral intention to use LMS. There are 3 items in the scale. Respondents were asked to answer the questions on a 5-point Likert scale (1: Strongly Disagree, 2: Disagree, 3: Neutral, 4: Agree, 5: Strongly Agree). As a result, respondents have tendency to use LMS since their responses are higher than the average value (3.00) (Table 7).

Table 7. Mean Values of Behavioral Intention to Use LMS

Scale Item	Mean	Std. Deviation
Given the chance, I intend to use the learning management system to do different things, from downloading lecture notes and participating in chat rooms to learning on the Web.	3.60	1.043
I predict I would use the learning management system in the next semester.	3.90	1.044
In general, I plan to use the learning management system frequently for my coursework and other activities in the next semester.	3.72	1.056
Valid N (listwise) = 282		

#### 5.1.2 Descriptive statistics for perceived usefulness

This part of the questionnaire attempts to measure the tendency of respondents in terms of perceived usefulness of LMS. There are 6 items in the scale. Respondents were asked to answer the questions on a 5-point Likert scale (1: Strongly Disagree, 2: Disagree, 3: Neutral, 4: Agree, 5: Strongly Agree). As a result, since their responses are higher than the average value (3.00), respondents find LMS useful (Table 8).

Table 8. Mean Values of Perceived Usefulness

Scale Item	Mean	Std. Deviation
Using LMS will allow me to accomplish learning tasks more quickly.	3.61	0.899
Using LMS will improve my learning performance.	3.55	0.908
Using LMS will make it easier to learn course content.	3.82	0.908
Using will increase my learning productivity.	3.55	0.935
Using LMS will enhance my effectiveness in learning.	3.56	0.916
This system helps me keep active and motivated as I can have LMS available in my work/leisure space.	3.43	1.039
Valid N (listwise) = 282		



### 5.1.3 Descriptive statistics for perceived ease of use

This part of the questionnaire attempts to measure the tendency of respondents in terms of perceived ease of use of LMS. There are 6 items in the scale. Respondents were asked to answer the questions on a 5-point Likert scale (1: Strongly Disagree, 2: Disagree, 3: Neutral, 4: Agree, 5: Strongly Agree). As a result, since their responses are higher than the average value (3.00), respondents find LMS easy to use (Table 9).

Table 9. Mean Values of Perceived Ease of Use

Scale Item	Mean	Std. Deviation
Learning to operate LMS is easy for me.	3.95	0.963
I find it easy to get LMS to do what I want it to do.	3.89	0.990
My interaction with LMS is clear and understandable.	3.97	0.947
It is easy for me to become skillful at using LMS.	3.82	0.995
I find LMS easy to use.	3.93	1.001
It is easy to get materials from LMS.	4.15	0.892
Valid N (listwise)= 282		

### 5.1.4 Descriptive statistics for perceived interaction

This part of the questionnaire attempts to measure the tendency of respondents in terms of perceived interaction of LMS. There are 3 items in the scale. Respondents were asked to answer the questions on a 5-point Likert scale (1: Strongly Disagree, 2: Disagree, 3: Neutral, 4: Agree, 5: Strongly Agree). As a result, since their responses are lower than the average value (3.00), respondents do not find LMS useful for communication with others (Table 10).

Table 10. Mean Values of Perceived Interaction

Scale Item	Mean	Std. Deviation
I discuss relevant learning topics with others on the discussion board.	2.44	1.162
I send e-mails to others as a way of communicating.	2.64	1.281
In general, I think this LMS environment provides good opportunities for interaction with other users.	2.83	1.148
Valid N (listwise)= 282		

### 5.1.5 Descriptive statistics for social norm

This part of the questionnaire attempts to measure the tendency of respondents in terms of social norm of LMS. There are 3 items in the scale. Respondents were asked to answer the questions on a 5-point Likert scale (1: Strongly Disagree, 2: Disagree, 3: Neutral, 4: Agree, 5: Strongly Agree). As a result, since their responses are higher than the average value (3.00), respondents care about other people's thoughts (Table 11).

Table 11. Mean Values of Social Norm

Scale Item	Mean	Std. Deviation
My Instructors thinks that it is important to use the learning management system.	3.72	0.957
Other students think that it is important to use the learning management system.	3.42	1.003
My friends think that it is important to use the learning management system.	3.39	1.069
Valid N (listwise)= 282		

### 5.1.6 Descriptive statistics for compatibility with preferred work style

This part of the questionnaire attempts to find out that LMS is compatible with respondents' work style. There are 3 items in the scale. Respondents were asked to answer the questions on a 5-point Likert scale (1: Strongly Disagree, 2: Disagree, 3: Neutral, 4: Agree, 5: Strongly Agree). As a result, since their responses are higher than the average value (3.00), respondents find LMS more compatible with their work style (Table 12).

Table 12. Mean Values of Compatibility with Preferred Work Style

Scale Item	Mean	Std. Deviation
Using the learning management system is compatible with my study.	3.72	0.751
Using the learning management system fits well with my personal, academic and professional development needs.	3.62	0.881
I think that using the learning management system fit well with the way I like to study.	3.57	0.914
Valid N (listwise)= 282		

### 5.1.7 Descriptive statistics for compatibility with user interface design

This part of the questionnaire attempts to measure the thought of respondents about the interface design of LMS. There are 4 items in the scale. Respondents were asked to answer the questions on a 5-point Likert scale (1: Strongly Disagree, 2: Disagree, 3: Neutral, 4: Agree, 5: Strongly Agree). As a result, since their responses are higher than the average value (3.00), respondents find the interface design LMS appropriate (Table 13).

Table 13. Mean Values of User Interface Design

Scale Items	Mean	Std. Deviation
LMS layout is user-friendly.	3.45	0.916
LMS layout is in good structure.	3.50	0.925
Overall, LMS user-interface design is satisfactory.	3.47	0.981
The layout design of the LMS makes it easy to read.	3.57	0.919
Valid N (listwise)= 282		

#### 5.1.8 Descriptive statistics for computer self-efficacy

This part of the questionnaire attempts to measure the tendency of respondents in terms of computer self-efficacy. There are 6 items in the scale. Respondents were asked to answer the questions on a 5-point Likert scale (1: Strongly Disagree, 2: Disagree, 3: Neutral, 4: Agree, 5: Strongly Agree). As a result, since their responses are higher than the average value (3.00), respondents are competent to use LMS (Table 14).

Table 14. Mean Values of Computer Self-Efficacy

Scale Items	Mean	Std. Deviation
I can access the contents of the learning management system.	4.07	0.744
I can freely navigate the contents of the learning management system.	3.84	0.874
I can use the learning management system without needing to be told how it functions.	3.87	0.911
I can solve problems that arise on the learning management system.	3.50	1.017
I can use the learning management system if there are user manuals available.	3.62	0.985
Overall, I am able to use the learning management system.	4.25	0.776
Valid N (listwise)= 282		

### 5.1.9 Descriptive statistics for previous online learning experience

This part of the questionnaire attempts to measure the previous online learning experience of respondents. There are 4 items in the scale. Respondents were asked to answer the questions on a 5-point Likert scale (1: Strongly Disagree, 2: Disagree, 3: Neutral, 4: Agree, 5: Strongly Agree). As a result, since their responses are higher than the average value (3.00), respondents have previous experience about LMS (Table 15).

Table 15. Mean Values of Previous Online Learning Experience

Scale Items	Mean	Std. Deviation
I will have a better knowledge of how to use LMS if a teacher or peer shows me how to use it first.	3.23	1.080
I will have a better knowledge of how to use LMS if there is an online utility to guide me.	3.40	1.026
I will have a better knowledge of how to use LMS if I have previously used any of LMSs.	3.70	0.943
I feel it would easier to operate the system if I had previous experience of using it.	3.78	0.924
Valid N (listwise)= 282		

### 5.2 Reliability / internal consistency of the survey items and scales

Reliability of the survey items including 9 scales has been checked by Cronbach's Alpha (Table 16).

Table 16. Cronbach's Alpha Values of All Scales

Factors	Number of Items	Cronbach's Alpha
Behavioral Intention to Use (BIU)	3	0.722
Perceived Usefulness (PU)	6	0.909
Perceived Ease of Use (PEOU)	6	0.937
Perceived Interaction (PI)	3	0.814
Social Norm (SN)	3	0.869
Compatibility with Preferred Work Style (CPWS)	3	0.867
User Interface Design (UID)	4	0.903
Computer Self-Efficacy (CSE)	6	0.824
Previous Online Learning Experience (POLE)	4	0.810

#### 5.2.1 Reliability analysis for behavioral intention to use LMS scale

Cronbach's Alpha value of Behavioral Intention to Use LMS Scale is 0.722 which is greater than 0.7 as seen in Table 16. This result shows that items in this scale are consistent with each other for measuring behavioral intention to use LMS. See Appendix B, Table B1 for detailed information and SPSS results.

#### 5.2.2 Reliability analysis for perceived usefulness scale

Cronbach's Alpha value of Perceived Usefulness Scale is 0.909 which is greater than 0.7 as seen in Table 16. This result shows that items in this scale are consistent with each other for measuring Perceived Usefulness. See Appendix B, Table B2 for detailed information and SPSS results.

#### 5.2.3 Reliability analysis for perceived ease of use scale

Cronbach's Alpha value of Perceived Ease of Use Scale is 0.937 which is greater than 0.7 as seen in Table 16. This result shows that items in this scale are consistent with each

other for measuring Perceived Ease of Use. See Appendix B, Table B3 for detailed information and SPSS results.

#### 5.2.4 Reliability analysis for perceived interaction scale

Cronbach's Alpha value of Perceived Interaction Scale is 0.814 which is greater than 0.7 as seen in Table 16. This result shows that items in this scale are consistent with each other for measuring Perceived Interaction. See Appendix B, Table B4 for detailed information and SPSS results.

#### 5.2.5 Reliability analysis for social norm scale

Cronbach's Alpha value of Social Norm Scale is 0.869 which is greater than 0.7 as seen in Table 16. This result shows that items in this scale are consistent with each other for measuring Social Norm. See Appendix B, Table B5 for detailed information and SPSS results.

#### 5.2.6 Reliability analysis for compatibility with preferred work style scale

Cronbach's Alpha value of Compatibility with Preferred Work Style Scale is 0.867 which is greater than 0.7 as seen in Table 16. This result shows that items in this scale are consistent with each other for measuring Compatibility with Preferred Work Style. See Appendix B, Table B6 for detailed information and SPSS results.

#### 5.2.7 Reliability Analysis for User Interface Design Scale

Cronbach's Alpha value of User Interface Design Scale is 0.903 which is greater than 0.7 as seen in Table 16. This result shows that items in this scale are consistent with each

other for measuring User Interface Design. See Appendix B, Table B7 for detailed information and SPSS results.

#### 5.2.8 Reliability analysis for computer self-efficacy scale

Cronbach's Alpha value of Computer Self-Efficacy Scale is 0.824 which is greater than 0.7 as seen in Table 16. This result shows that items in this scale are consistent with each other for measuring Computer Self-Efficacy. See Appendix B, Table B8 for detailed information and SPSS results.

#### 5.2.9 Reliability analysis for previous online learning experience scale

Cronbach's Alpha value of Previous Online Learning Experience Scale is 0.810 which is greater than 0.7 as seen in Table 16. This result shows that items in this scale are consistent with each other for measuring Previous Online Learning Experience. See Appendix B, Table B9 for detailed information and SPSS results.

### 5.3 Hypotheses testing

#### 5.3.1 Regression analyses

To measure the relationship between independent variables and the dependent variable, regression analyses is conducted. For this, the average values of all variables are calculated using SPSS. All items of scales are consistent with each other and scales are reliable.



### 5.3.1.1 Hypothesis 1:

Hypothesis 1 is “Perceived Usefulness (PU) will positively affect the Behavioral Intention to Use (BIU) a learning management system”. In order to test this hypothesis, linear regression analysis is conducted.

Model summary shows that R value is 0.480 and R square value is 0.230 which mean regression result is satisfying but it is required to check significance levels.

Table 17. Model Summary for Hypothesis 1

Model	R	R Square	Adjusted R Square	Std. Error of the Estimate
1	0.480 <sup>a</sup>	0.230	0.227	0.738
a. Predictors: (Constant), PU				

Anova result shows that significance level of predictor Perceived Usefulness is under 0.05 so it is significant (in Table 18). This means that, there is a strong positive relationship between PU and BIU.

Table 18. ANOVA<sup>a</sup> for Hypothesis 1

Model		Sum of Squares	df	Mean Square	F	Sig.
1	Regression	45.612	1	45.612	83.699	0.000 <sup>b</sup>
	Residual	152.588	280	0.545		
	Total	198.201	281			
a. Dependent Variable: BIU						
b. Predictors: (Constant), PU						

According to coefficient table (Table 19), coefficient of Perceived Usefulness is significant so Perceived Usefulness (PU) can be used in an equation as a predictor of Behavioral Intention to Use (BIU) a learning management system. Thus, hypothesis 1 is supported. Equation can be written as  $BIU = a + 0.48 PU$  (Table 19).

Table 19. Coefficients<sup>a</sup> for Hypothesis 1

Model		Unstandardized Coefficients		Standardized Coefficients	t	Sig.
		B	Std. Error	Beta		
1	(Constant)	1.876	0.208		9.003	0.000
	PU	0.519	0.057	0.48	9.149	0.000
a. Dependent Variable: BIU						

### 5.3.1.2 Hypothesis 2:

Hypothesis 2 is “Perceived Ease of Use will positively affect the Perceived Usefulness of a learning management system”. In order to test this hypothesis, linear regression analysis was conducted.

Model summary shows that R value is 0.478 and R square value is 0.229 which mean regression result is satisfying but it is required to check significance levels.

Table 20. Model Summary for Hypotheses 2

Model	R	R Square	Adjusted R Square	Std. Error of the Estimate
1	0.478 <sup>a</sup>	0.229	0.226	0.682
a. Predictors: (Constant), PEOU				

Anova result shows that significance level of predictor Perceived Ease of Use is under 0.05 so it is significant (in Table 21). This means that, there is a strong positive relationship between PEOU and PU.

Table 21. ANOVA<sup>a</sup> for Hypotheses 2

Model		Sum of Squares	df	Mean Square	F	Sig.
1	Regression	38.659	1	38.659	83.041	0.000 <sup>b</sup>
	Residual	130.352	280	0.466		
	Total	169.011	281			
a. Dependent Variable: PU						
b. Predictors: (Constant), PEOU						

According to coefficient table (Table 22), coefficient of Perceived Ease of Use is significant so Perceived Ease of Use (PEOU) can be used in an equation as a predictor of Perceived Usefulness (PU). Thus, hypothesis 2 is supported. Equation can be written as  $PU = a + 0.478 \text{ PEOU}$  (Table 22).

Table 22. Coefficients<sup>a</sup> for Hypotheses 2

Model		Unstandardized Coefficients		Standardized Coefficients	t	Sig.
		B	Std. Error	Beta		
1	(Constant)	1.847	0.195		9.462	0.000
	PEOU	0.44	0.048	0.478	9.113	0.000
a. Dependent Variable: PU						

### 5.3.1.3 Hypothesis 3:

Hypothesis 3 is “Perceived Ease of Use will positively affect the Perceived Interaction with a learning management system”. In order to test this hypothesis, linear regression analysis was conducted.

Model summary shows that R value is 0.306 and R square value is 0.093 which mean regression result is satisfying but it is required to check significance levels.

Table 23. Model Summary for Hypothesis 3

Model	R	R Square	Adjusted R Square	Std. Error of the Estimate
1	0.306 <sup>a</sup>	0.093	0.090	0.976
a. Predictors: (Constant), PEOU				

Anova result shows that significance level of predictor Perceived Ease of Use is under 0.05 so it is significant (Table 24). This means that, there is a strong positive relationship between PEOU and PI.

Table 24. ANOVA<sup>a</sup> for Hypothesis 3

Model		Sum of Squares	df	Mean Square	F	Sig.
1	Regression	27.505	1	27.505	28.880	0.000 <sup>b</sup>
	Residual	266.673	280	0.952		
	Total	294.178	281			
a. Dependent Variable: PI						
b. Predictors: (Constant), PEOU						

According to coefficient table (Table 25), coefficient of Perceived Ease of Use is significant so Perceived Ease of Use (PEOU) can be used in an equation as a predictor of Perceived Interaction (PI). Thus, hypothesis 3 is supported. Equation can be written as  $PI = a + 0.306 \text{ PEOU}$  (Table 25).

Table 25. Coefficients<sup>a</sup> for Hypothesis 3

Model		Unstandardized Coefficients		Standardized Coefficients	t	Sig.
		B	Std. Error	Beta		
1	(Constant)	1.169	0.279		4.186	0.000
	PEOU	0.371	0.069	0.306	5.374	0.000

a. Dependent Variable: PI

#### 5.3.1.4 Hypothesis 4:

Hypothesis 4 is “Perceived Ease of Use will positively affect the Intention to Use a learning management system”. In order to test this hypothesis, linear regression analysis was conducted.

Model summary shows that R value is 0.422 and R square value is 0.178 which mean regression result is satisfying but it is required to check significance levels.

Table 26. Model Summary for Hypothesis 4

Model	R	R Square	Adjusted R Square	Std. Error of the Estimate
1	0.422 <sup>a</sup>	0.178	0.175	0.763

a. Predictors: (Constant), PEOU

Anova result shows that significance level of predictor Perceived Ease of Use is under 0.05 so it is significant (Table 27). This means that, there is a strong positive relationship between PEOU and BIU.

Table 27. ANOVA<sup>a</sup> for Hypothesis 4

Model		Sum of Squares	df	Mean Square	F	Sig.
1	Regression	35.291	1	35.291	60.656	0.000 <sup>b</sup>
	Residual	162.910	280	0.582		
	Total	198.201	281			
a. Dependent Variable: BIU						
b. Predictors: (Constant), PEOU						

According to coefficient table (Table 28), coefficient of Perceived Ease of Use is significant so Perceived Ease of Use (PEOU) can be used in an equation as a predictor of Behavioral Intention to Use (BIU) a learning management system. Thus, hypothesis 4 is supported. Equation can be written as  $BIU = a + 0.422 PEOU$  (Table 28).

Table 28. Coefficients<sup>a</sup> for Hypothesis 4

Model		Unstandardized Coefficients		Standardized Coefficients	t	Sig.
		B	Std. Error	Beta		
1	(Constant)	2.077	0.218		9.518	0.000
	PEOU	0.421	0.054	0.422	7.788	0.000
a. Dependent Variable: BIU						

### 5.3.1.5 Hypothesis 5:

Hypothesis 5 is “Perceived Interaction will positively affect the Intention to Use a learning management system”. In order to test this hypothesis, linear regression analysis was conducted.

Model summary shows that R value is 0.198 and R square value is 0.039 which mean regression result is satisfying but it is required to check significance levels.

Table 29. Model Summary for Hypothesis 5

Model	R	R Square	Adjusted R Square	Std. Error of the Estimate
1	0.198 <sup>a</sup>	0.039	0.036	0.825
a. Predictors: (Constant), PI				

Anova result shows that significance level of predictor Perceived Interaction is under 0.05 so it is significant (Table 30). This means that, there is a strong positive relationship between PI and BIU.

Table 30. ANOVA<sup>a</sup> for Hypothesis 5

Model		Sum of Squares	df	Mean Square	F	Sig.
1	Regression	7.746	1	7.746	11.388	0.001 <sup>b</sup>
	Residual	190.454	280	0.680		
	Total	198.201	281			
a. Dependent Variable: BIU						
b. Predictors: (Constant), PI						

According to coefficient table (Table 31), coefficient of Perceived Interaction is significant so Perceived Interaction (PI) can be used in an equation as a predictor of

Behavioral Intention to Use (BIU) a learning management system. Thus, hypothesis 5 is supported. Equation can be written as  $BIU = a + 0.198 PI$  (Table 31).

Table 31. Coefficients<sup>a</sup> for Hypothesis 5

Model		Unstandardized Coefficients		Standardized Coefficients	t	Sig.
		B	Std. Error	Beta		
1	(Constant)	3.311	0.136		24.358	0.000
	PI	0.162	0.048	0.198	3.375	0.001

a. Dependent Variable: BIU

#### 5.3.1.6 Hypothesis 6:

Hypothesis 6 is “Social Norm will positively effect on student’s behavioral intention to use online learning system”. In order to test this hypothesis, linear regression analysis was conducted.

Model summary shows that R value is 0.416 and R square value is 0.173 which mean regression result is satisfying but it is required to check significance levels.

Table 32. Model Summary for Hypothesis 6

Model	R	R Square	Adjusted R Square	Std. Error of the Estimate
1	0.416 <sup>a</sup>	0.173	0.170	0.765

a. Predictors: (Constant), SN



Anova result shows that significance level of predictor Social Norm is under 0.05 so it is significant (Table 33). This means that, there is a strong positive relationship between SN and BIU.

Table 33. ANOVA<sup>a</sup> for Hypothesis 6

Model		Sum of Squares	df	Mean Square	F	Sig.
1	Regression	34.369	1	34.369	58.739	0.000 <sup>b</sup>
	Residual	163.831	280	0.585		
	Total	198.201	281			
a. Dependent Variable: BIU						
b. Predictors: (Constant), SN						

According to coefficient table (Table 34), coefficient of Social Norm is significant so Social Norm (SN) can be used in an equation as a predictor of Behavioral Intention to Use (BIU) a learning management system. Thus, hypothesis 6 is supported. Equation can be written as  $BIU = a + 0.416 SN$  (Table 34).

Table 34. Coefficients<sup>a</sup> for Hypothesis 6

Model		Unstandardized Coefficients		Standardized Coefficients	t	Sig.
		B	Std. Error	Beta		
1	(Constant)	2.375	0.184		12.937	0.000
	SN	0.389	0.051	0.416	7.664	0.000
a. Dependent Variable: BIU						

### 5.3.1.7 Hypothesis 7:

Hypothesis 7 is “Social Norm will positively affect the Perceived Usefulness of a learning management system”. In order to test this hypothesis, linear regression analysis was conducted.

Model summary shows that R value is 0.550 and R square value is 0.303 which mean regression result is satisfying but it is required to check significance levels.

Table 35. Model Summary for Hypothesis 7

Model	R	R Square	Adjusted R Square	Std. Error of the Estimate
1	0.550 <sup>a</sup>	0.303	0.301	0.649
a. Predictors: (Constant), SN				

Anova result shows that significance level of predictor Social Norm is under 0.05 so it is significant (Table 36). This means that, there is a strong positive relationship between SN and PU.

Table 36. ANOVA<sup>a</sup> for Hypothesis 7

Model		Sum of Squares	df	Mean Square	F	Sig.
1	Regression	51.217	1	51.217	121.743	0,000 <sup>b</sup>
	Residual	117.795	280	0.421		
	Total	169.011	281			
a. Dependent Variable: PU						
b. Predictors: (Constant), SN						

According to coefficient table (Table 37), coefficient of Social Norm is significant so Social Norm (SN) can be used in an equation as a predictor of Perceived

Usefulness (PU). Thus, hypothesis 7 is supported. Equation can be written as below:

$$PU = a + 0.550 SN \text{ (Table 37).}$$

Table 37. Coefficients<sup>a</sup> for Hypothesis 7

Model		Unstandardized Coefficients		Standardized Coefficients	t	Sig.
		B	Std. Error	Beta		
1	(Constant)	1.922	0.156		12.344	0.000
	SN	0.474	0.043	0.550	11.034	0.000
a. Dependent Variable: BIU						

### 5.3.1.8 Hypothesis 8:

Hypothesis 8 is “Compatibility with Preferred Work Style will positively effect on student’s behavioral intention to use online learning system”. In order to test this hypothesis, linear regression analysis was conducted.

Model summary shows that R value is 0.483 and R square value is 0.234 which mean regression result is satisfying but it is required to check significance levels.

Table 38. Model Summary for Hypothesis 8

Model	R	R Square	Adjusted R Square	Std. Error of the Estimate
1	0.483 <sup>a</sup>	0.234	0.231	0.737
a. Predictors: (Constant), CPWS				

Anova result shows that significance level of predictor Compatibility with Preferred Work Style is under 0.05 so it is significant. This means that, there is a strong positive relationship between CPWS and BIU.

Table 39. ANOVA<sup>a</sup> for Hypothesis 8

Model		Sum of Squares	df	Mean Square	F	Sig.
1	Regression	46.289	1	46.289	85.318	0.000 <sup>b</sup>
	Residual	151.912	280	0.543		
	Total	198.201	281			
a. Dependent Variable: BIU						
b. Predictors: (Constant), CPWS						

According to coefficient table (Table 40), coefficient of Compatibility with Preferred Work Style is significant so Compatibility with Preferred Work Style (CPWS) can be used in an equation as a predictor of Behavioral Intention to Use (BIU) a learning management system. Thus, hypothesis 8 is supported. Equation can be written as below:  $BIU = a + 0.483 CPWS$  (Table 40).

Table 40. Coefficients<sup>a</sup> for Hypothesis 8

Model		Unstandardized Coefficients		Standardized Coefficients	t	Sig.
		B	Std. Error	Beta		
1	(Constant)	1.786	0.216		8.273	0
	CPWS	0.536	0.058	0.483	9.237	0
a. Dependent Variable: BIU						

#### 5.3.1.9 Hypothesis 9:

Hypothesis 9 is “Compatibility with Preferred Work Style will positively effect on Perceived Usefulness of a learning management system”. In order to test this hypothesis, linear regression analysis was conducted.

Model summary shows that R value is 0.731 and R square value is 0.535 which mean regression result is satisfying but it is required to check significance levels.

Table 41. Model Summary for Hypothesis 9

Model	R	R Square	Adjusted R Square	Std. Error of the Estimate
1	0.731 <sup>a</sup>	0.535	0.533	0.52976
a. Predictors: (Constant), CPWS				

Anova result shows that significance level of predictor Compatibility with Preferred Work Style is under 0.05 so it is significant (Table 42). This means that, there is a strong positive relationship between CPWS and PU.

Table 42. ANOVA<sup>a</sup> for Hypothesis 9

Model		Sum of Squares	df	Mean Square	F	Sig.
1	Regression	90.431	1	90.431	322.230	0.000 <sup>b</sup>
	Residual	78.580	280	0.281		
	Total	169.011	281			
a. Dependent Variable: PU						
b. Predictors: (Constant), CPWS						

According to coefficient table (Table 43), coefficient of Compatibility with Preferred Work Style is significant so Compatibility with Preferred Work Style (CPWS) can be used in an equation as a predictor of Perceived Usefulness (PU). Thus, hypothesis 9 is supported. Equation can be written as below:

$$PU = a + 0.731 \text{ CPWS (Table 43).}$$

Table 43. Coefficients<sup>a</sup> for Hypothesis 9

Model		Unstandardized Coefficients		Standardized Coefficients	t	Sig.
		B	Std. Error	Beta		
1	(Constant)	0.857	0.155		5.520	0
	CPWS	0.750	0.042	0.731	17.951	0
a. Dependent Variable: PU						

5.3.1.10 Hypothesis 10:

Hypothesis 10 is “User-interface Design will positively affect Perceived Usefulness of a learning management system”. In order to test this hypothesis, linear regression analysis was conducted.

Model summary shows that R value is 0.491 and R square value is 0.242 which mean regression result is satisfying but it is required to check significance levels.

Table 44. Model Summary for Hypothesis 10

Model	R	R Square	Adjusted R Square	Std. Error of the Estimate
1	0.491 <sup>a</sup>	0.242	0.239	0.677
a. Predictors: (Constant), UID				

Anova result shows that significance level of predictor User Interface Design is under 0.05 so it is significant (Table 45). This means that, there is a strong positive relationship between UID and PU.

Table 45. ANOVA<sup>a</sup> for Hypothesis 10

Model		Sum of Squares	df	Mean Square	F	Sig.
1	Regression	40.828	1	40.828	89.185	0.000 <sup>b</sup>
	Residual	128.183	280	0.458		
	Total	169.011	281			
a. Dependent Variable: PU						
b. Predictors: (Constant), UID						

According to coefficient table (Table 46), coefficient of User Interface Design is significant so User Interface Design (UID) can be used in an equation as a predictor of Perceived Usefulness (PU). Thus, hypothesis 10 is supported. Equation can be written as below:

$$PU = a + 0.491 \text{ UID (Table 46).}$$

Table 46. Coefficients<sup>a</sup> for Hypothesis 10

Model		Unstandardized Coefficients		Standardized Coefficients	t	Sig.
		B	Std. Error	Beta		
1	(Constant)	1.966	0.176		11.160	0.000
	UID	0.463	0.049	0.491	9.444	0.000
a. Dependent Variable: PU						

#### 5.3.1.11 Hypothesis 11:

Hypothesis 11 is “User-interface Design will positively affect the Perceived Ease of Use of a learning management system”. In order to test this hypothesis, linear regression analysis was conducted.

Model summary shows that R value is 0.639 and R square value is 0.408 which mean regression result is satisfying but it is required to check significance levels.

Table 47. Model Summary for Hypothesis 11

Model	R	R Square	Adjusted R Square	Std. Error of the Estimate
1	0.639 <sup>a</sup>	0.408	0.406	0.649
a. Predictors: (Constant), UID				

Anova result shows that significance level of predictor User Interface Design is under 0.05 so it is significant. This means that, there is a strong positive relationship between UID and PEOU.

Table 48. ANOVA<sup>a</sup> for Hypothesis 11

Model		Sum of Squares	df	Mean Square	F	Sig.
1	Regression	81.455	1	81.455	193.129	0.000 <sup>b</sup>
	Residual	118.093	280	0.422		
	Total	199.548	281			
a. Dependent Variable: PEOU						
b. Predictors: (Constant), UID						

According to coefficient table (Table 49), coefficient of User Interface Design is significant so User Interface Design (UID) can be used in an equation as a predictor of Perceived Ease of Use (PEOU). Thus, hypothesis 11 is supported. Equation can be written as below:

$$PEOU = a + 0.639 \text{ UID (Table 49).}$$



Table 49. Coefficients<sup>a</sup> for Hypothesis 11

Model		Unstandardized Coefficients		Standardized Coefficients	t	Sig.
		B	Std. Error	Beta		
1	(Constant)	1.664	0.169		9.839	0.000
	UID	0.654	0.047	0.639	13.897	0.000

a. Dependent Variable: PEOU

5.3.1.12 Hypothesis 12:

Hypothesis 12 is “User-interface Design will positively affect Perceived Interaction of a learning management system”. In order to test this hypothesis, linear regression analysis was conducted.

Model summary shows that R value is 0.368 and R square value is 0.136 which mean regression result is satisfying but it is required to check significance levels.

Table 50. Model Summary for Hypothesis 12

Model	R	R Square	Adjusted R Square	Std. Error of the Estimate
1	0.368 <sup>a</sup>	0.136	0.133	0.953

a. Predictors: (Constant), UID

Anova result shows that significance level of predictor User Interface Design is under 0.05 so it is significant (Table 51). This means that, there is a strong positive relationship between UID and PI.

Table 51. ANOVA<sup>a</sup> for Hypothesis 12

Model		Sum of Squares	df	Mean Square	F	Sig.
1	Regression	39.903	1	39.903	43.94	0.000 <sup>b</sup>
	Residual	254.275	280	0.908		
	Total	294.178	281			
a. Dependent Variable: PI						
b. Predictors: (Constant), UID						

According to coefficient table (Table 52), coefficient of User Interface Design is significant so User Interface Design (UID) can be used in an equation as a predictor of Perceived Interaction (PI). Thus, hypothesis 12 is supported. Equation can be written as below:

$$PI = a + 0.368 \text{ UID (Table 52).}$$

Table 52. Coefficients<sup>a</sup> for Hypothesis 12

Model		Unstandardized Coefficients		Standardized Coefficients	t	Sig.
		B	Std. Error	Beta		
1	(Constant)	1.034	0.248		4.169	0.000
	UID	0.458	0.069	0.368	6.629	0.000
a. Dependent Variable: PI						

### 5.3.1.13 Hypothesis 13:

Hypothesis 13 is “Computer Self-efficacy will positively affect Perceived Usefulness of a learning management system”. In order to test this hypothesis, linear regression analysis was conducted.

Model summary shows that R value is 0.495 and R square value is 0.245 which mean regression result is satisfying but it is required to check significance levels.

Table 53. Model Summary for Hypothesis 13

Model	R	R Square	Adjusted R Square	Std. Error of the Estimate
1	0.495 <sup>a</sup>	0.245	0.242	0.675
a. Predictors: (Constant), CSE				

Anova result shows that significance level of predictor Computer Self-efficacy is under 0.05 so it is significant (Table 54). This means that, there is a strong positive relationship between CSE and PU.

Table 54. ANOVA<sup>a</sup> for Hypothesis 13

Model		Sum of Squares	df	Mean Square	F	Sig.
1	Regression	41.412	1	41.412	90.873	0.000 <sup>b</sup>
	Residual	127.599	280	0.456		
	Total	169.011	281			
a. Dependent Variable: PU						
b. Predictors: (Constant), CSE						

According to coefficient table (Table 55), coefficient of Computer Self-efficacy is significant so Computer Self-efficacy (CSE) can be used in an equation as a predictor of Perceived Usefulness (PU). Thus, hypothesis 13 is supported. Equation can be written as below:

$$PU = a + 0.495 \text{ CSE (Table 55).}$$

Table 55. Coefficients<sup>a</sup> for Hypothesis 13

Model		Unstandardized Coefficients		Standardized Coefficients	t	Sig.
		B	Std. Error	Beta		
1	(Constant)	1.305	0.243		5.379	0.000
	CSE	0.591	0.062	0.495	9.533	0.000

a. Dependent Variable: PU

5.3.1.14 Hypothesis 14:

Hypothesis 14 is “Computer Self-efficacy will positively affect Perceived Ease of Use of a learning management system”. In order to test this hypothesis, linear regression analysis was conducted.

Model summary shows that R value is 0.690 and R square value is 0.477 which mean regression result is satisfying but it is required to check significance levels.

Table 56. Model Summary for Hypothesis 14

Model	R	R Square	Adjusted R Square	Std. Error of the Estimate
1	0.690 <sup>a</sup>	0.477	0.475	0.611

a. Predictors: (Constant), CSE

Anova result shows that significance level of predictor Computer Self-efficacy is under 0.05 so it is significant (Table 57). This means that, there is a strong positive relationship between CSE and PEOU.

Table 57. ANOVA<sup>a</sup> for Hypothesis 14

Model		Sum of Squares	df	Mean Square	F	Sig.
1	Regression	95.123	1	95.123	255.06	0.000 <sup>b</sup>
	Residual	104.425	280	0.373		
	Total	199.548	281			
a. Dependent Variable: PEOU						
b. Predictors: (Constant), CSE						

According to coefficient table (Table 58), coefficient of Computer Self-efficacy is significant so Computer Self-efficacy (CSE) can be used in an equation as a predictor of Perceived Ease of Use (PEOU). Thus, hypothesis 14 is supported. Equation can be written as below:

$$\text{PEOU} = a + 0.690 \text{ CSE (Table 58).}$$

Table 58. Coefficients<sup>a</sup> for Hypothesis 14

Model		Unstandardized Coefficients		Standardized Coefficients	t	Sig.
		B	Std. Error	Beta		
1	(Constant)	0.495	0.220		2.254	0.025
	CSE	0.896	0.056	0.690	15.971	0.000
a. Dependent Variable: PEOU						

### 5.3.1.15 Hypothesis 15:

Hypothesis 15 is “Computer Self-efficacy will positively affect the Intention to Use a learning management system”. In order to test this hypothesis, linear regression analysis was conducted.

Model summary shows that R value is 0.425 and R square value is 0.181 which mean regression result is satisfying but it is required to check significance levels.

Table 59. Model Summary for Hypothesis 15

Model	R	R Square	Adjusted R Square	Std. Error of the Estimate
1	0.425 <sup>a</sup>	0.181	0.178	0.761
a. Predictors: (Constant), CSE				

Anova result shows that significance level of predictor Computer Self-efficacy is under 0.05 so it is significant (Table 60). This means that, there is a strong positive relationship between CSE and BIU.

Table 60. ANOVA<sup>a</sup> for Hypothesis 15

Model		Sum of Squares	df	Mean Square	F	Sig.
1	Regression	35.857	1	35.857	61.844	0.000 <sup>b</sup>
	Residual	162.344	280	0.580		
	Total	198.201	281			
a. Dependent Variable: BIU						
b. Predictors: (Constant), CSE						

According to coefficient table (Table 61), coefficient of Computer Self-efficacy is significant so Computer Self Efficacy (CSE) can be used in an equation as a predictor of Behavioral Intention to Use (BIU) a learning management system. Thus, hypothesis 15 is supported. Equation can be written as below:

$$BIU = a + 0.425 \text{ CSE (Table 61).}$$

Table 61. Coefficients<sup>a</sup> for Hypothesis 15

Model		Unstandardized Coefficients		Standardized Coefficients	t	Sig.
		B	Std. Error	Beta		
1	(Constant)	1.616	0.274		5.905	0.000
	CSE	0.550	0.070	0.425	7.864	0.000

a. Dependent Variable: BIU

5.3.1.16 Hypothesis 16:

Hypothesis 16 is “Previous Online Learning Experience will positively affect the Perceived Usefulness of a learning management system”. In order to test this hypothesis, linear regression analysis was conducted.

Model summary shows that R value is 0.256 and R square value is 0.065 which mean regression result is satisfying but it is required to check significance levels.

Table 62. Model Summary for Hypothesis 16

Model	R	R Square	Adjusted R Square	Std. Error of the Estimate
1	0.256 <sup>a</sup>	0.065	0.062	0.751

a. Predictors: (Constant), POLE

Anova result shows that significance level of predictor Previous Online Learning Experience is under 0.05 so it is significant (Table 63). This means that, there is a strong positive relationship between POLE and PU.

Table 63. ANOVA<sup>a</sup> for Hypothesis 16

Model		Sum of Squares	df	Mean Square	F	Sig.
1	Regression	11.034	1	11.034	19.556	0.000 <sup>b</sup>
	Residual	157.978	280	0.564		
	Total	169.011	281			
a. Dependent Variable: PU						
b. Predictors: (Constant), POLE						

According to coefficient table (Table 64), coefficient of Previous Online Learning Experience is significant so Previous Online Learning Experience (POLE) can be used in an equation as a predictor of Perceived Usefulness (PU). Thus, hypothesis 16 is supported. Equation can be written as below:

$$PU = a + 0.425 \text{ POLE (Table 64).}$$

Table 64. Coefficients<sup>a</sup> for Hypothesis 16

Model		Unstandardized Coefficients		Standardized Coefficients	t	Sig.
		B	Std. Error	Beta		
1	(Constant)	2.706	0.204		13.264	0.000
	POLE	0.249	0.056	0.256	4.422	0.000
a. Dependent Variable: PU						

#### 5.3.1.17 Hypothesis 17:

Hypothesis 17 is “Previous Online Learning Experience will positively affect the Perceived Ease of Use of a learning management system”. In order to test this hypothesis, linear regression analysis was conducted.

Model summary shows that R value is 0.126 and R square value is 0.016 which mean regression result is satisfying but it is required to check significance levels.



Table 65. Model Summary for Hypothesis 17

Model	R	R Square	Adjusted R Square	Std. Error of the Estimate
1	0.126 <sup>a</sup>	0.016	0.012	0.837
a. Predictors: (Constant), POLE				

Anova result shows that significance level of predictor Previous Online Learning Experience is under 0.05 so it is significant (Table 66). This means that, there is a strong positive relationship between POLE and PEOU.

Table 66. ANOVA<sup>a</sup> for Hypothesis 17

Model		Sum of Squares	df	Mean Square	F	Sig.
1	Regression	3.162	1	3.162	4.508	0.035 <sup>b</sup>
	Residual	196.386	280	0.701		
	Total	199.548	281			
a. Dependent Variable: PEOU						
b. Predictors: (Constant), POLE						

According to coefficient table (Table 67), coefficient of Previous Online Learning Experience is significant so Previous Online Learning Experience (POLE) can be used in an equation as a predictor of Perceived Usefulness (PU). Thus, hypothesis 17 is supported. Equation can be written as below:

$$PEOU = a + 0.126 \text{ POLE (Table 67).}$$

Table 67. Coefficients<sup>a</sup> for Hypothesis 17

Model		Unstandardized Coefficients		Standardized Coefficients	t	Sig.
		B	Std. Error	Beta		
1	(Constant)	3.481	0.227		15.303	0.000
	POLE	0.134	0.063	0.126	2.123	0.035

a. Dependent Variable: PEOU

5.3.1.18 Hypothesis 18:

Hypothesis 18 is “Previous Online Learning Experience will positively affect the Intention to Use a learning management system”. In order to test this hypothesis, linear regression analysis was conducted.

Model summary shows that R value is 0.105 and R square value is 0.011 which mean regression result is satisfying but it is required to check significance levels.

Table 68. Model Summary for Hypothesis 18

Model	R	R Square	Adjusted R Square	Std. Error of the Estimate
1	0.105 <sup>a</sup>	0.011	0.007	0.837

a. Predictors: (Constant), POLE

Anova result shows that significance level of predictor Previous Online Learning Experience is more than 0.05 so it is not significant (Table 69). This means that, there is no strong positive relationship between POLE and BIU.

Table 69. ANOVA<sup>a</sup> for Hypothesis 18

Model		Sum of Squares	df	Mean Square	F	Sig.
1	Regression	2.183	1	2.183	3.119	0.078 <sup>b</sup>
	Residual	196.017	280	0.700		
	Total	198.201	281			
a. Dependent Variable: BIU						
b. Predictors: (Constant), POLE						

According to coefficient table (Table 70), coefficient of Previous Online Learning Experience has no direct effect on BIU and cannot be used as a predictor. Thus, hypothesis 18 is rejected.

Table 70. Coefficients<sup>a</sup> for Hypothesis 18

Model		Unstandardized Coefficients		Standardized Coefficients	t	Sig.
		B	Std. Error	Beta		
1	(Constant)	3.347	0.227		14.729	0.000
	POLE	0.111	0.063	0.105	1.766	0.078
a. Dependent Variable: BIU						

### 5.3.1.19 Hypotheses table summary

The summary of the SPSS hypotheses tests are shown below table (Table 71):

Table 71. Summary of SPSS Hypotheses Test Results.

	Hypothesis		Support
H1	PU	→ BIU	Yes
H2	PEOU	→ PU	Yes
H3	PEOU	→ PI	Yes
H4	PEOU	→ BIU	Yes
H5	PI	→ BIU	Yes
H6	SN	→ BIU	Yes
H7	SN	→ PU	Yes
H8	CPWS	→ BIU	Yes
H9	CPWS	→ PU	Yes
H10	UID	→ PU	Yes
H11	UID	→ PEOU	Yes
H12	UID	→ PI	Yes
H13	CSE	→ PU	Yes
H14	CSE	→ PEOU	Yes
H15	CSE	→ BIU	Yes
H16	POLE	→ PU	Yes
H17	POLE	→ PEOU	Yes
H18	POLE	→ BIU	No

### 5.3.2 Group differences

#### 5.3.2.1 T-test for gender differences on the behavioral intention to use (BIU) an LMS

According to T-test for gender in Table 72, the average score of sample on BIU is very close to each other but it is required to check significance level of T-test.

Table 72. Group Statistics of Gender

	Gender	N	Mean	Std. Deviation	Std. Error Mean
BIU	Male	160	3.640	0.866	0.068
	Female	122	3.869	0.788	0.071

According to significance value of T-test in Table 73, there is no difference between behavioral intention to use an LMS in terms of sample's gender because the significance value is 0.441 and is not smaller than 0.05. The detailed result can be seen Appendix C, Table C1.

Table 73. Independent Samples Test for Gender

		Levene's Test for Equality of Variances		t-test for Equality of Means		
		F	Sig.	t	df	Sig. (2-tailed)
BIU	Equal variances assumed	0.595	0.441	-2.288	280	0.023
	Equal variances not assumed			-2.317	271.321	0.021

### 5.3.2.2 T-test for university differences on the behavioral intention to use (BIU) an LMS

According to T-test for university in Table 74, the average score of sample on BIU is very close to each other but it is required to check significance level of T-test.

Table 74. Group Statistics of University Differences

	University Name	N	Mean	Std. Deviation	Std. Error Mean
BIU	Istanbul Bilgi University	160	3.773	0.887	0.070
	Boğaziçi University	122	3.694	0.774	0.070

According to significance value of T-test in Table 75, there is no difference between behavioral intention to use an LMS in terms of sample's university because the significance value is 0.176 and is not smaller than 0.05. The detailed result can be seen Appendix C, Table C2.

Table 75. Independent Samples Test for University Differences

		Levene's Test for Equality of Variances		t-test for Equality of Means		
		F	Sig.	t	df	Sig. (2-tailed)
BIU	Equal variances assumed	1.842	0.176	0.781	280	0.435
	Equal variances not assumed			0.796	274.879	0.427

### 5.3.2.3 T-test for LMS differences on the behavioral intention to use (BIU) an LMS

According to T-test for LMS in Table 76, the average score of sample on BIU is very close to each other but it is required to check significance level of T-test.

Table 76. Group Statistics of LMS Differences

	Name of LMS	N	Mean	Std. Deviation	Std. Error Mean
BIU	BlackBoard	157	3.758	0.887	0.071
	Moodle	125	3.715	0.779	0.070

According to significance value of T-test in Table 77, there is no difference between behavioral intention to use an LMS in terms of sample's name of LMS because the significance value is 0.223 and is not smaller than 0.05. The detailed result can be seen Appendix C, Table C3.

Table 77. Independent Samples Test for LMS Differences

		Levene's Test for Equality of Variances		t-test for Equality of Means		
		F	Sig.	t	df	Sig. (2-tailed)
BIU	Equal variances assumed	1.491	0.223	0.429	280	0.668
	Equal variances not assumed			0.436	277.286	0.663

#### 5.3.2.4 One way Anova for education level on the behavioral intention to use (BIU) an LMS

According to descriptive statistics about educational level in Table 78, the average of BUI is increasing but number of sample is not distributed equally and so, whether this increase is coincidental or not, it is required to check significance level of ANOVA.

Table 78. Descriptives for Educational Level according to BIU an LMS

	N	Mean	Std. Deviation	Std. Error	95% Confidence Interval for Mean	
					Lower Bound	Upper Bound
Undergraduate	254	3.714	0.846	0.053	3.609	3.818
MA	19	3.947	0.803	0.184	3.560	4.334
PHD	9	4.000	0.687	0.229	3.472	4.528
Total	282	3.739	0.840	0.050	3.640	3.837

The significance value of ANOVA is seen as 0.323 in Table 79. This value should be smaller than 0.05 but it is not. This means that students' Behavioral Intention to Use an LMS do not change with the level of educational.

Table 79. ANOVA for Educational Level according to BIU an LMS

	Sum of Squares	df	Mean Square	F	Sig.
Between Groups	1.598	2	0.799	1.134	0.323
Within Groups	196.603	279	0.705		
Total	198.201	281			

### 5.3.3 Factor analysis

#### 5.3.3.1 Factor analysis of behavioral intention to use (BIU)

For the factor analysis of BIU, only one factor is seen in Table 80 as we thought. All factor loading values are satisfying and 64.918% of total variance is explained.



Table 80. Factor Analysis for BIU

Factor	Factor Loading	Cumulative Variance Explained (%)
BIU1	0.654	64.918
BIU2	0.873	
BIU3	0.871	

### 5.3.3.2 Factor analysis of perceived usefulness (PU)

For the factor analysis of PU, only one factor is seen in Table 81 as we thought. All factor loading values are satisfying and 69.16% of total variance is explained.

Table 81. Factor Analysis for PU

Factor	Factor Loading	Cumulative Variance Explained (%)
PU1	0.795	69.16
PU2	0.881	
PU3	0.799	
PU4	0.863	
PU5	0.862	
PU6	0.784	

### 5.3.3.3 Factor analysis of perceived ease of use (PEOU)

For the factor analysis of PEOU, only one factor is seen in Table 82 as we thought. All factor loading values are satisfying and 76.226% of total variance is explained.

Table 82. Factor Analysis for PEOU

Factor	Factor Loading	Cumulative Variance Explained (%)
PEOU1	0.872	76.226
PEOU2	0.876	
PEOU3	0.896	
PEOU4	0.874	
PEOU5	0.899	
PEOU6	0.819	

#### 5.3.3.4 Factor analysis of perceived interaction (PI)

For the factor analysis of PI, only one factor is seen in Table 83 as we thought. All factor loading values are satisfying and 73.005% of total variance is explained.

Table 83. Factor Analysis for PI

Factor	Factor Loading	Cumulative Variance Explained (%)
PI1	0.839	73.005
PI2	0.864	
PI3	0.860	

#### 5.3.3.5 Factor analysis of previous online learning experience (POLE)

For the factor analysis of POLE, only one factor is seen in Table 84 as we thought. All factor loading values are satisfying and 64.247% of total variance is explained.

Table 84. Factor Analysis for POLE

Factor	Factor Loading	Cumulative Variance Explained (%)
POLE1	0.738	64.247
POLE2	0.793	
POLE3	0.833	
POLE4	0.839	

#### 5.3.3.6 Factor analysis of user interface design (UID)

For the factor analysis of UID, only one factor is seen in Table 85 as we thought. All factor loading values are satisfying and 77.43% of total variance is explained.

Table 85. Factor Analysis for UID

Factor	Factor Loading	Cumulative Variance Explained (%)
UID1	0.891	77.43
UID2	0.882	
UID3	0.899	
UID4	0.847	

### 5.3.3.7 Factor analysis of social norm (SN)

For the factor analysis of SN, only one factor is seen in Table 86 as we thought. All factor loading values are satisfying and 79.39% of total variance is explained.

Table 86. Factor Analysis for SN

Factor	Factor Loading	Cumulative Variance Explained (%)
SN1	0.830	79.39
SN2	0.928	
SN3	0.912	

### 5.3.3.8 Factor analysis of compatibility with preferred work style (CPWS)

For the factor analysis of CPWS, only one factor is seen in Table 87 as we thought. All factor loading values are satisfying and 79.386% of total variance is explained.

Table 87. Factor Analysis for CPWS

Factor	Factor Loading	Cumulative Variance Explained (%)
CPWS1	0.883	79.386
CPWS2	0.911	
CPWS3	0.879	

### 5.3.3.9 Factor analysis of compatibility with preferred work style (CPWS)

For the factor analysis of CPWS, only one factor is seen in Table 88 as we thought. All factor loading values are satisfying and 79.386% of total variance is explained.

Table 88. Factor Analysis for CPWS

Factor	Factor Loading	Cumulative Variance Explained (%)
CPWS1	0.883	79.386
CPWS2	0.911	
CPWS3	0.879	

#### 5.3.3.10 Factor analysis of computer self-efficacy (CSE)

For the factor analysis of CSE, only one factor is seen in Table 89 as we thought. All factor loading values are satisfying and 55.457% of total variance is explained.

Table 89. Factor Analysis for CSE

Factor	Factor Loading	Cumulative Variance Explained (%)
CSE1	0.799	55.457
CSE2	0.823	
CSE3	0.794	
CSE4	0.710	
CSE5	0.509	
CSE6	0.786	

#### 5.4 Final model for regression analysis

According to the regression analysis, all hypotheses are confirmed except for hypothesis 18 (seen on Figure 20). After the SPSS analysis, SEM analysis will be used for the model fit and for the creation of study model because SEM analyses all data and variables as a whole. The detailed information will be explained in the next section.

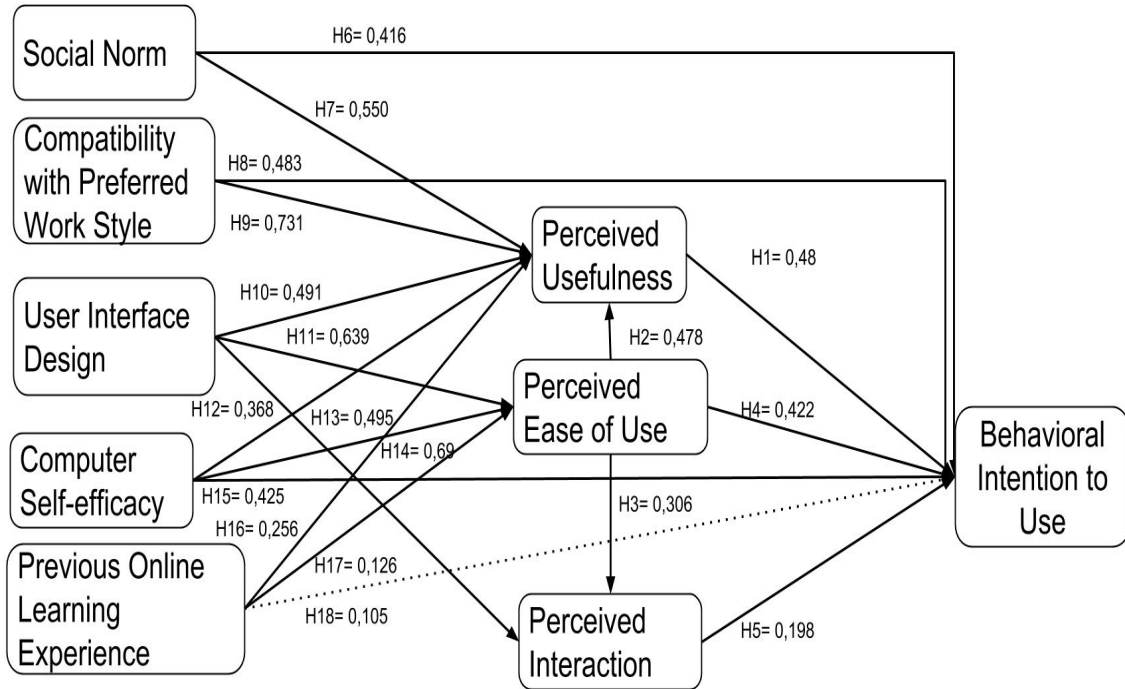

Figure 20. Final model for regression analysis with path values

### 5.5 Structural equation modeling (SEM) results

According to Byrne (2010), for SEM analysis, there are two model types: measurement model “depicting the links between the latent variables and their observed measures (i.e., the CFA model)” and structural model “depicting the links among the latent variables themselves”.

In this study, Cheng’s incremental approach (2001) will be used for SEM analysis and model testing (on Figure 21). According to Cheng, “this model helps to establish the ‘best fitting’ measurement model and the ‘best fitting’ structural model using SEM”. However, it is not easy to find the best fitting model because it is needed to create a series of structural models and to test them.

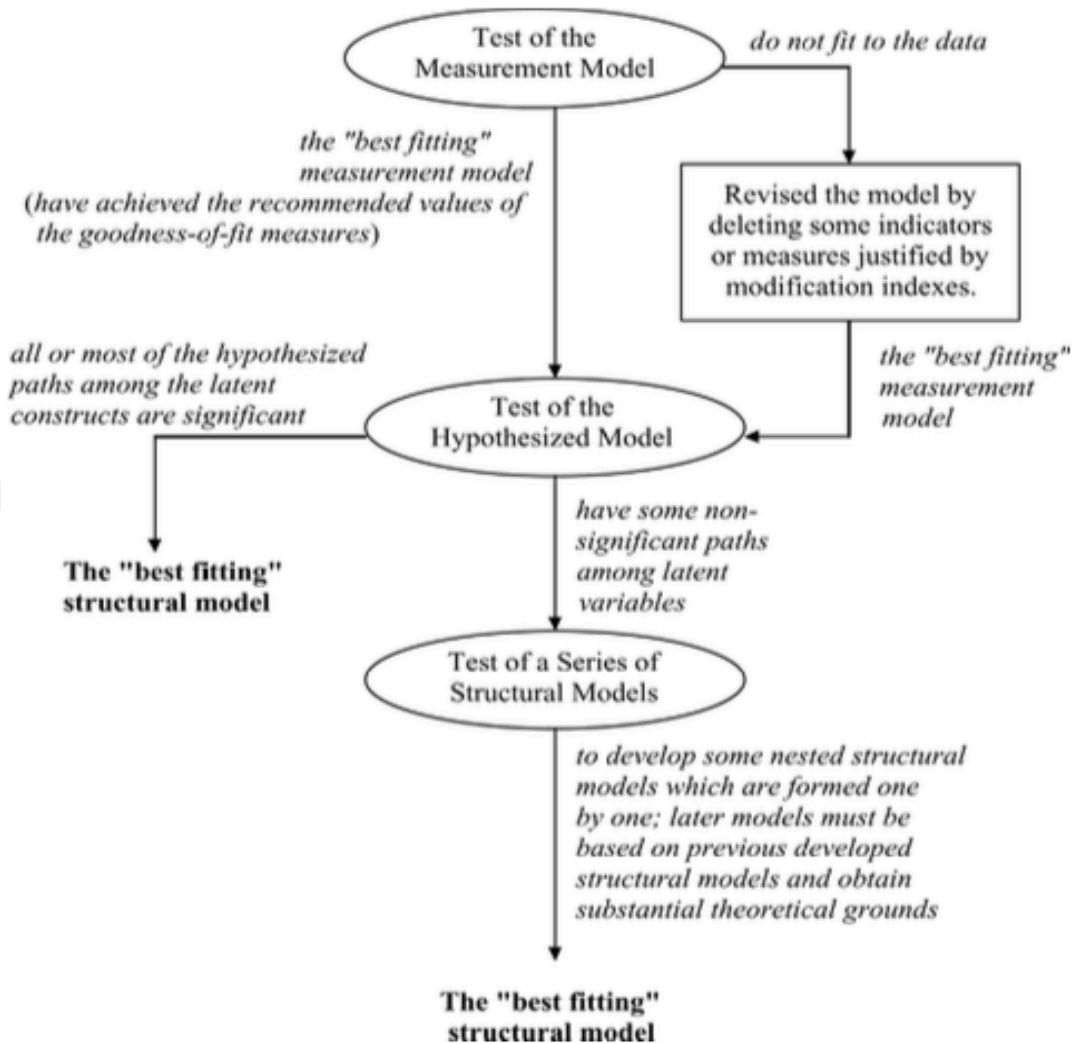

Figure 21. A flowchart of the incremental approach to SEM (Cheng, 2001)

Firstly, the measurement model (Figure 22) is drawn using AMOS “draw covariances” plugins and the values of normality, factor loadings, and reliabilities are measured.

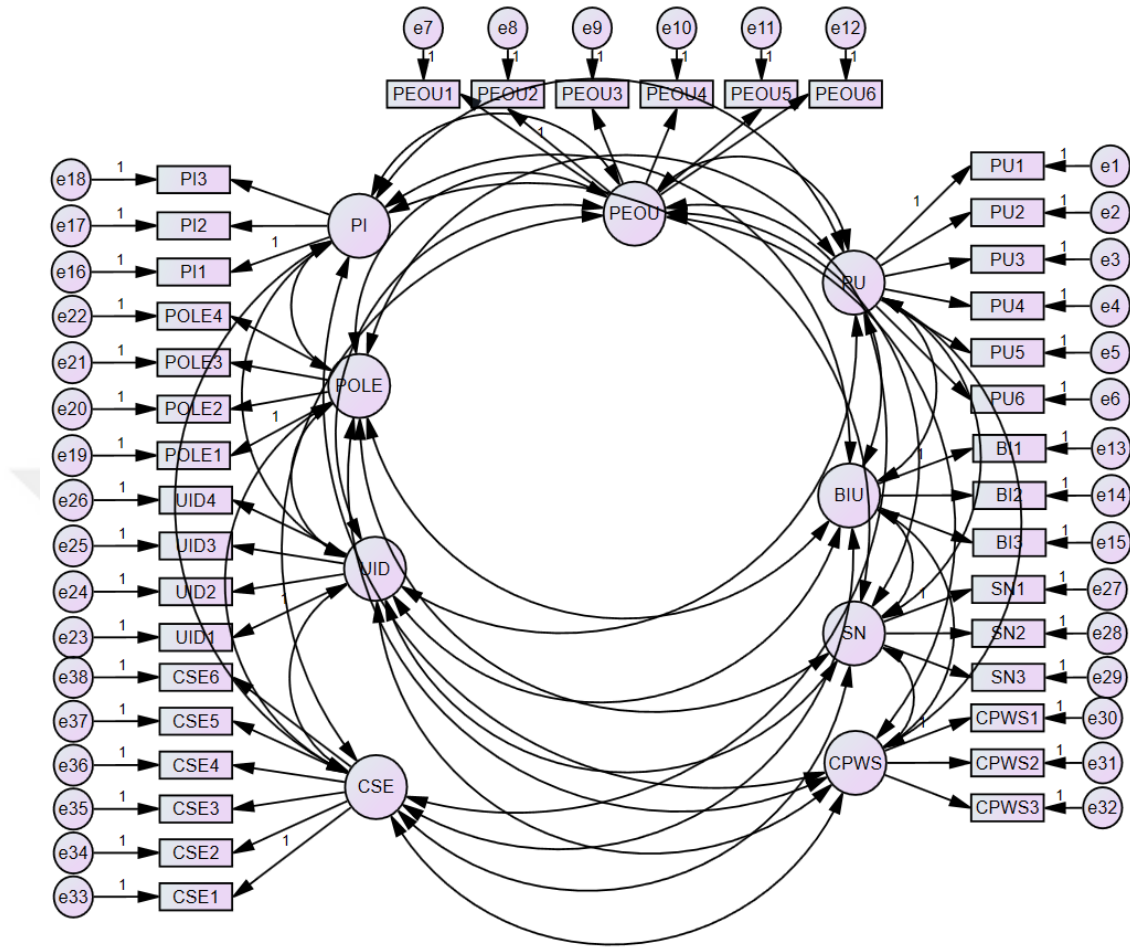

Figure 22. Amos covariance diagram for measurement model

### 5.5.1 Confirmatory factor analysis (CFA)

#### 5.5.1.1 Assessment of normality

According to Byrne (2010), the skew and kurtosis values of factors should be between -3 and 3 in normal distribution. In Appendix D, Table D2, the distributions of them are shown. The value of skew is between -1.23 and 0.303 and the value of kurtosis is between -1.165 and 2.362. This shows that the data is normally distributed.

### 5.5.1.2 Factor loadings

Confirmatory Factor Analysis (CFA) is used to find factor loadings because we do not use a new questionnaire and have some knowledge of the underlying latent variable structure (Byrne, 2010). Factor loadings are called in AMOS as “Standardized Regression Weights”. The recommended factor loading is 0.50 or higher (Junior, Joseph, Anderson, & Tatham, 1992; Park, 2009; Escobar-Rodriguez & Monge-Lozano, 2012; Kilic, 2014; Ahmed & Ward, 2016) and ideally 0.70 or higher (Karahanna et al., 2006; Ahmed & Ward, 2016). According to Junior et al. (1992), if the factor loading value is greater than 0.5, it is significant. If the condition is not satisfied, the variables under 0.5 must be deleted for the sake of getting good results. According to covariance analysis, CSE5 is 0.39 and deleted from the model (See in Appendix D, Table D1). However, the factor loading of BIU1 is 0.45 lower than 0.50 but close to. According to Urbach and Ahlemann (2010) and Sanchez and Hueros (2010), if any factor loading exceeds 0.4, the measurement satisfies the validity. Also, according to Raubenheimer (2004), if a scale measures more than one factor, each factor is analysed at least three items but there are examples about two items per factor despite seen as the exception. Thus, BIU is measured with three items in this study and BIU1 is not deleted from the model due to the explained reasons and good validity and reliability values are explained in the next part. Finally, factor loading squared, measurement errors and p-values were calculated, and they are seen significant with p value 0.001 in Table 90.



Table 90. Confirmatory Factor Analysis Results

Latent Variable	Indicator	Factor Loading	Factor Loading Squared	Measurement Error	p-Value
Perceived Usefulness	PU1	0.75	0.56	0.44	-*
	PU2	0.86	0.74	0.26	0.001
	PU3	0.75	0.56	0.44	0.001
	PU4	0.84	0.71	0.29	0.001
	PU5	0.84	0.70	0.30	0.001
	PU6	0.73	0.53	0.47	0.001
Perceived Ease of Use	PEOU1	0.84	0.70	0.30	-*
	PEOU2	0.85	0.72	0.28	0.001
	PEOU3	0.88	0.77	0.23	0.001
	PEOU4	0.85	0.73	0.27	0.001
	PEOU5	0.88	0.77	0.23	0.001
	PEOU6	0.78	0.60	0.40	0.001
Behavioral Intention to Use	BIU1	0.45	0.21	0.79	-*
	BIU2	0.76	0.58	0.42	0.001
	BIU3	0.88	0.77	0.23	0.001
Perceived Interaction	PI1	0.72	0.52	0.48	-*
	PI2	0.77	0.59	0.41	0.001
	PI3	0.82	0.67	0.33	0.001
Previous Online Learning	POLE1	0.50	0.25	0.75	-*
	POLE2	0.58	0.33	0.67	0.001
	POLE3	0.88	0.77	0.23	0.001
	POLE4	0.87	0.75	0.25	0.001
User Interface Design	UID1	0.86	0.73	0.27	-*
	UID2	0.85	0.73	0.27	0.001
	UID3	0.86	0.74	0.26	0.001
	UID4	0.78	0.60	0.40	0.001
Social Norm	SN1	0.70	0.49	0.51	-*
	SN2	0.93	0.86	0.14	0.001
	SN3	0.88	0.77	0.23	0.001
Compatibility with Preferred Work Style	CPWS1	0.83	0.69	0.31	-*
	CPWS2	0.86	0.74	0.26	0.001
	CPWS3	0.81	0.65	0.35	0.001
Computer Self-Efficacy	CSE1	0.77	0.59	0.41	-*
	CSE2	0.77	0.60	0.40	0.001
	CSE3	0.74	0.54	0.46	0.001
	CSE4	0.63	0.39	0.61	0.001
	CSE6	0.75	0.57	0.43	0.001

\*not estimated when loading set to fixed value of 1.0

### 5.5.1.3 Construct validity

According to Byrne (2010), construct validity focuses on convergent validity and discriminant validity. Convergent validity is “the extent to which different assessment methods concur in the measurement of the same trait (i.e., construct; ideally, these values should be moderately high)” and discriminant validity is “the extent to which independent assessment methods diverge in the measurement of different traits” (ideally, these values should demonstrate minimal convergence) (Byrne, 2010).

Convergent validity values are related to Average Variance Extracted (AVE) and Composite Reliability (CR). The threshold value for CR is commonly used as 0.7 and for AVE is 0.5 (Park, 2009; Escobar-Rodriguez & Monge-Lozano, 2012; Kilic, 2014; Tarhini et al., 2014; Ahmed & Ward, 2016). If the values exceed those values, they are accepted as significant. In this study, the values are seen in Table 91, values for AVE ranges from 0.52 to 0.72 and values for CR ranges from 0.75 to 0.94. In short, they have acceptable values.

Table 91. Convergent and Discriminant Validity Values

	CR	BIU	PU	PEOU	PI	POLE	UID	SN	CPWS	CSE
BIU	0.75	0.52								
PU	0.91	0.26	0.63							
PEOU	0.94	0.21	0.25	0.72						
PI	0.81	0.05	0.18	0.14	0.59					
POLE	0.81	0.02	0.09	0.05	0.10	0.53				
UID	0.90	0.16	0.28	0.48	0.20	0.09	0.70			
SN	0.88	0.21	0.34	0.19	0.08	0.04	0.24	0.71		
CPWS	0.87	0.30	0.65	0.43	0.24	0.11	0.49	0.43	0.69	
CSE	0.85	0.23	0.29	0.64	0.13	0.07	0.49	0.19	0.52	0.54

Discriminant validity compares the square of correlation between constructs and AVE values and the AVE values should be greater than the square of correlation value (Escobar-Rodriguez & Monge-Lozano, 2012; Ahmed & Ward, 2016). The discriminant validity values are calculated as seen in Table 91. Most of the AVE values of constructs are greater than the square of correlation except perceived usefulness and compatibility with preferred work style, and perceived ease of use and computer self-efficacy. However, these four constructs are totally different than each other. Thus, it can be concluded that nearly all constructs provide discriminant validity requirement.

#### 5.5.1.4 Model fit values for measurement model

Firstly, according to the literature, acceptable values for SEM are listed below:

- Chi-squared/degree of freedom is equal or lower than 3 (Sanchez & Hueros, 2010; Tarhini et al., 2014; Ros et al., 2015)
- GFI is equal or greater than 0.8 (Hsu & Lin, 2008)
- Comparative Fit Index (CFI) is equal or greater than 0.9 (Byrne, 2010; Sanchez & Hueros, 2010; Tarhini et al., 2014; Ros et al., 2015)
- Normed Fit Index (NFI) is equal or greater than 0.8 (Ros et al., 2015)
- Root Mean Squared Error of Approximation (RMSEA) is equal or lower than 0.08 (Sanchez & Hueros, 2010; Tarhini et al., 2014) or 0.10 (Park, 2009; Ros et al., 2015).

According to SEM analysis, chi-squared/degree of freedom is 1.901, GFI is 0.82, CFI is 0.92, NFI is 0.85 and RMSEA is 0.06. All values are in acceptable range (see Appendix D, Tables D3-D12 for detailed results).

Next step is to test the series of structural models to find “best fitting” structural model (Cheng, 2001).

### 5.5.2 Hypothesized structural model

Initial structural model is formed as shown in Figure 23. As seen from the Table 92, the model fit values are not in acceptable range. For this reason as Cheng (2001) specifies constructs are deleted from the structure and the best model fitting is searched until it is found.

Table 92. Model Fit Values for Figure 23

chi-squared /degree of freedom	2.66
GFI	0.74
CFI	0.86
NFI	0.79
RMSEA	0.08

According to Table 93, best model fitting results are achieved after deleting POLE, PI and CPWS constructs.

Table 93. Model Fit Values with Deleted Constructs

Deleted Constructs	chi-squared /degree of freedom	GFI	CFI	NFI	RMSEA
POLE - PI - CPWS	2.50	0.83	0.91	0.86	0.07
POLE - PI - UID	2.88	0.82	0.89	0.85	0.08
POLE - PI - CSE	2.77	0.83	0.91	0.86	0.08
POLE - PI - SN	2.82	0.81	0.89	0.84	0.08

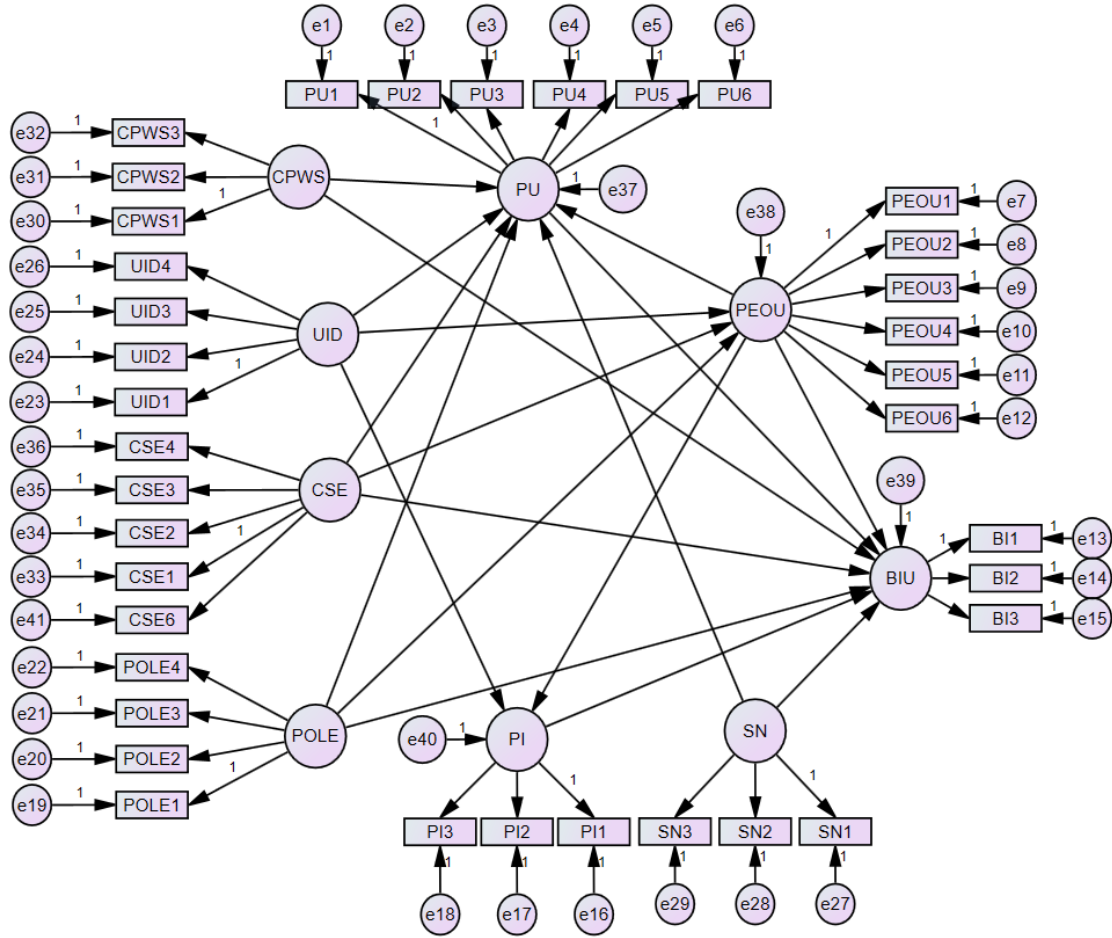

Figure 23. Hypothesized structural model

After the process of deleting determined constructs (POLE, PI and CPWS), the regression weights values are controlled and these values show that CSE has no effect on BIU and affects the regression of PEOU and PU adversely (Table 94). Thus, the relationships between CSE and BIU, and CSE and PU are removed from the model and new best fitting model is shown in Figure 24 and new regression values are in Table 95. Moreover, the value of PU and PEOU regression weight is not significant (Table 94) but it is not deleted due to the nature of TAM and after deleting CSE relations on the model, the regression weight between PU and PEOU is in acceptable range.

Table 94. Regression Weights before the Removal of Hypotheses of CSE

Relationships of Constructs	Regression Weights	p-value
PEOU <--- CSE	0.814	***
PEOU <--- UID	0.349	***
PU <--- CSE	0.257	0.010
PU <--- UID	0.160	0.004
PU <--- PEOU	0.043	0.607
PU <--- SN	0.408	***
BIU <--- PU	0.176	0.004
BIU <--- PEOU	0.070	0.211
BIU <--- SN	0.133	0.011
BIU <--- CSE	0.144	0.049

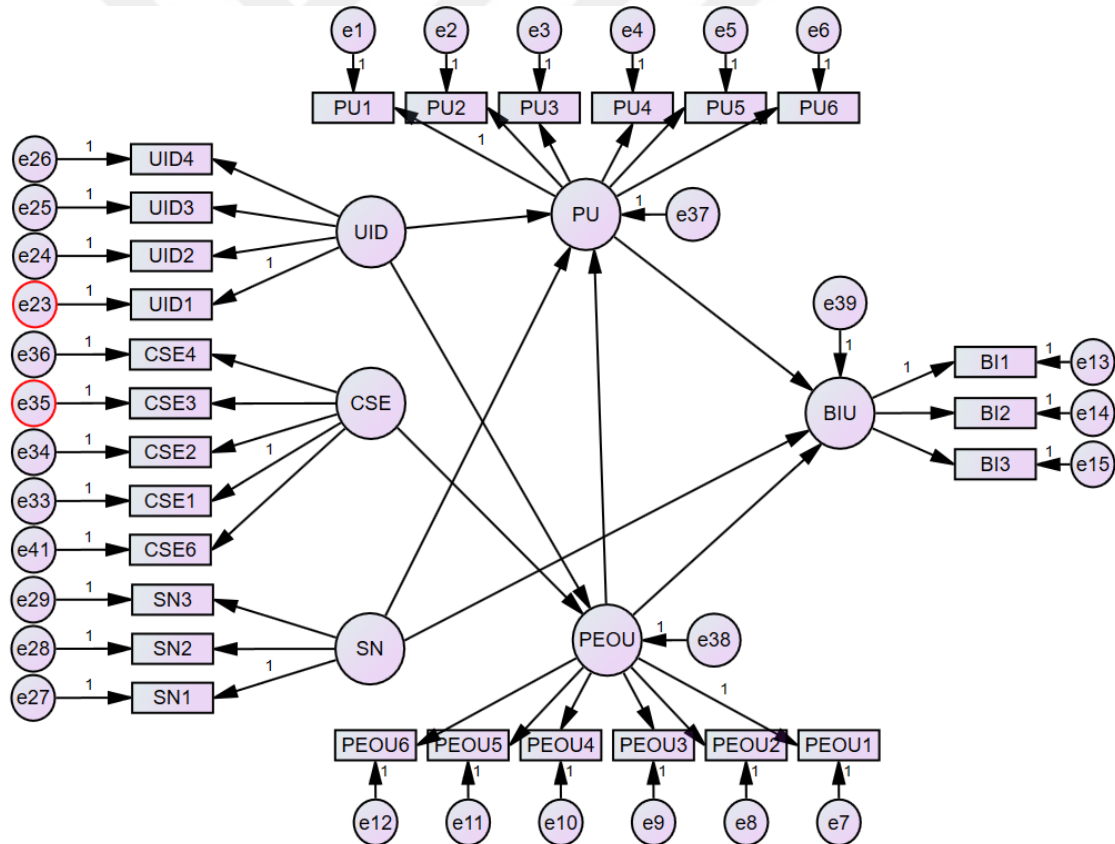

Figure 24. Final best fitting structural model

As seen in Table 95, first five hypotheses are significant at the alpha level of 0.01 and the others are significant at alpha level of 0.05.

Table 95. Regression Weights after the Removal of Hypotheses of CSE

Relationships of Constructs	Regression Weights	p-value
PEOU <--- CSE	0.828	***
PEOU <--- UID	0.344	***
PU <--- UID	0.169	***
PU <--- PEOU	0.182	***
PU <--- SN	0.416	***
BIU <--- PU	0.191	0.002
BIU <--- PEOU	0.146	0.001
BIU <--- SN	0.132	0.011

### 5.5.3 Final measurement model

After deleting determined constructs, it will be needed to draw measurement model to control the values of normality, factor loadings, and reliabilities. In Appendix D, Table D2, the new distributions of them are shown. The value of skew is between -1.23 and 0.27 and the value of kurtosis is between -0.45 and 2.362. The data is same only the range is changed due to deletion. This shows that the data is normally distributed. Also, final CFA values in Table 96 are same in the first model in Table 90. Thus, reliabilities are also the same. In short, they have acceptable values.

Table 96. Final Convergent and Discriminant Validity Values

	CR	BIU	PU	PEOU	UID	SN	CSE
BIU	0.75	0.52					
PU	0.91	0.26	0.63				
PEOU	0.94	0.21	0.25	0.72			
UID	0.90	0.16	0.28	0.48	0.70		
SN	0.88	0.21	0.34	0.19	0.24	0.71	
CSE	0.85	0.23	0.29	0.64	0.49	0.19	0.54

Most of the AVE values of constructs are greater than the square of correlation except perceived ease of use and computer self-efficacy. However, these two constructs are totally different than each other. Thus, it can be concluded that nearly all constructs provide discriminant validity requirement.

Finally, model fit values for measurement model that are in acceptable range is listed below:

- Chi-squared /degree of freedom is 2.50
- GFI is 0.83
- CFI is 0.91
- NFI is 0.86
- RMSEA is 0.07

Finally, six of nine constructs and eight of eighteen hypotheses are empirically supported. The supported hypotheses are listed as follows:

- Perceived Usefulness will positively affect the Behavioral Intention to Use of a learning management system.
- Perceived Ease of Use will positively affect the Perceived Usefulness of a learning management system.
- Perceived Ease of Use will positively affect the Intention to Use a learning management system.
- Social Norm will positively affect student's behavioral intention to use a learning management system.
- Social Norm will positively affect the Perceived Usefulness of a learning management system.



- User-interface Design will positively affect Perceived Usefulness of a learning management system.
- User-interface Design will positively affect the Perceived Ease of Use of a learning management system.
- Computer Self-efficacy will positively affect Perceived Ease of Use of a learning management system.

After SEM analysis, the final model is can be found in Figure 25. After deleting CPWS, POLE and PI, the model takes the final form and H3, H5, H8, H9, H12, H16, H17 and H18 are rejected automatically due to these deletions. Moreover, H13 (CSE->PU) and H15 (CSE->BIU) are deleted because the value of PU and PEOU regression weight is not significant due to these two hypotheses. According to the nature of TAM, PU and PEOU relation is always found positive and significant. Thus, after deleting H13 and H15 on the model, the regression weight between PU and PEOU is found in acceptable range in Table 95.

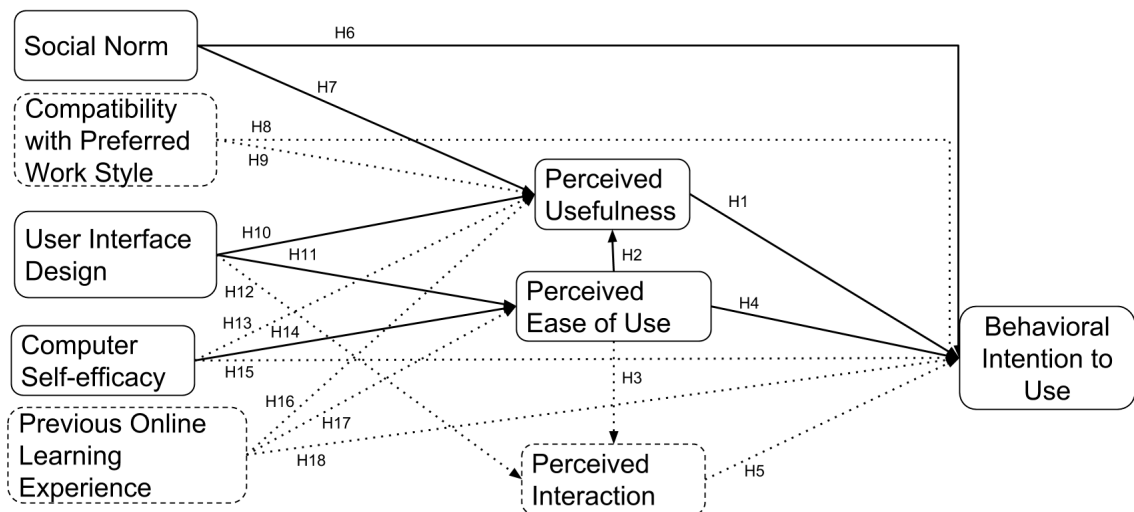

Figure 25. Final model

#### 5.5.4 Comparison of the data

Firstly, comparing the data about universities using SEM analysis, it is found that groups are not different at the model level but they may be different at the path level. The values of model level in the model comparison are;

- Df is 29
- CMIN is 30.726
- P value is 0.378 (the value is higher than 0.1 in 90% confidence thresholds).

Then all the p values at the path level are found for every hypothesis. The values are shown in Table 97. The p values of all hypotheses are greater than 0.1 except for the hypothesis between UID and PU. This means that the positive effect User Interface Design on Perceived Usefulness is stronger for Bilgi University than for Boğaziçi University. The reason for this may be the usage of LMS type. Some of students in Bilgi University used Moodle before the Blackboard. This can has effect on their opinion.

Table 97. P Values for Every Hypothesis

Hypothesis	Df	CMIN	P
PU->BIU	1	0.338	0.561
PEOU->BIU	1	1.392	0.238
SN->BIU	1	0.094	0.759
CSE->PEOU	1	0.481	0.488
UID->PEOU	1	0.220	0.639
PEOU->PU	1	0.836	0.360
SN->PU	1	0.290	0.590
UID->PU	1	3.724	0.054

Secondly, comparing the data about gender using SEM analysis, it is found that groups are different at the model level. The values of model level in the model comparison are:

- Df is 8
- CMIN is 19.973
- P value is 0.01 (the value is lower than 0.05 in 95% confidence thresholds).

Then all the p values at the model level are shown in Table 98. The p values of 7 hypotheses are lower than 0.01 in 99% confidence interval thresholds, and the p values of 1 hypothesis is lower than 0.05 in 95% confidence interval thresholds.

Table 98. P Values for Every Hypothesis

Hypothesis	P
PU->BIU	0.003
PEOU->BIU	***
SN->BIU	0.011
CSE->PEOU	***
UID->PEOU	***
PEOU->PU	***
SN->PU	***
UID->PU	0.002

The hypotheses are listed below:

- The positive effect Perceived Usefulness on the Behavioral Intention to Use of a learning management system is stronger for male than female.
- The positive effect Perceived Ease of Use on the Perceived Usefulness of a learning management system is stronger for male than female.
- The positive effect Perceived Ease of Use on the Behavioral Intention to Use a learning management system is stronger for male than female.

- The positive effect Social Norm on the Perceived Usefulness of a learning management system is stronger for male than female.
- The positive effect User-interface Design on Perceived Usefulness of a learning management system is stronger for male than female.
- The positive effect User-interface Design on the Perceived Ease of Use of a learning management system is stronger for male than female.
- The positive effect Computer Self-efficacy on Perceived Ease of Use of a learning management system is stronger for male than female.

## CHAPTER 6

### DISCUSSION AND CONCLUSIONS

There is no area that does not use technology, and in every field its usage is increased and development of it is fast. In education, e-learning has taken place and allows learners to make their educational processes easier. They can share documents, communicate with instructors and their peers without any time or place restriction. Learning Management System is a software application that allows configuring the e-learning environment for users. Also, LMS provides the institutions to manage a large number of courses and their users.

The main purpose of this research was to examine students' acceptance of and intention to use LMSs for university education in Turkey using extended Technology Acceptance Model (e-TAM). E-TAM provides opportunity to find the dominant reason(s)/ factor(s) for learners when using a relatively new system. A survey is created by using literature and questionnaires are distributed either online on the Internet or as printed copies during class, lecture or appropriate time in order to collect the data. The questionnaire in this study contains 9 factors: perceived usefulness, perceived ease of use, perceived interaction, previous online learning experience, computer self-efficacy, compatibility with preferred work style, social/subjective norm and user-interface design.

The survey is composed of 10 parts. First part is about demographic information of participants and their LMS experiences. The other parts are about factors affecting participants' intention to use LMS and about future intention to use LMS. The questions are answered on a 5-point Likert scale ("Strongly Disagree", "Disagree", "Neutral",

“Agree”, “Strongly Agree”) and consisted of 38 items. The survey is applied to 282 participants at Istanbul Bilgi University (56.73%) and Boğaziçi University (43.26%). 43.3% of them are female and 56.7% of them are male. After receiving the sufficient number of participants, data is transferred to Excel and then transferred to Statistical Package for Social Sciences (SPSS) Version 20 and SPSS Amos 23 for SEM analysis.

In SPSS, the eighteen hypotheses are tested with the regression analysis and all hypotheses are supported except for H18 that is “Previous Online Learning Experience will positively affect the Intention to Use a learning management system”. However, in SEM analysis, three other factors are deleted to find the “best fitting” model, and eight of the eighteen hypotheses are supported. The detailed information will be given in Discussion part.

## 6.1 Discussion

According to Byrne (2010), most other multivariate procedures are essentially descriptive by nature (e.g., exploratory factor analysis), so that hypothesis testing is difficult, if not impossible. Also, multivariate relations can be analyzed easily and better by using SEM analysis. Thus, the framework of this study takes its final form thanks to SEM because the study consists of multiple dependent variables related with multiple connected independent variables.

In SEM analysis, there are two model types: measurement and structural. In measurement model, the values of normality, factor loadings, and reliabilities are measured and controlled by drawing covariances between variables. Normality of factors is found in the desired range and so; it was concluded that data was normally

distributed. After CFA, CSE5 was deleted due to low factor loading. Finally, the reliabilities of all constructs are calculated and they had acceptable values.

After finding the goodness-of-fit of the measurement model adequate, testing the series of structural models to find the “best fitting” model was done as Cheng’s suggestion (2001). The structural hypothesized model is drawn with nine factors and eighteen hypotheses, and controlled its model fit values. The values are not in the acceptable range. Thus, a series of structural models are drawn and the values are recorded. When POLE and PI are deleted together, the values have increased noticeably but not enough. CPWS, UID, CSE and SN are respectively deleted and the values are recorded in Table 93. It is seen that the “best fitting” values were found by the deletion of POLE, PI and CPWS. Then, the regression weights values are checked to support or reject the hypotheses, and it is realized that CSE has no effect on BIU and affects the regression of PEOU and PU adversely. Therefore, two hypotheses between CSE and BIU, and CSE and PU are deleted to move regression weight between PU and PEOU to an acceptable range. After deletion of three constructs and two hypotheses, the measurement model is drawn again to control the values of normality, factor loadings, and reliabilities but it is realized that they did not change. According to SEM analysis, eight supported hypotheses are explained below.

According to studies, the effect of PU on BIU is mostly found significant (Davis, 1986, 1989 and 1993; Davis et al., 1989; Lederer et al., 2000; Karahanna et al., 2006; Liu et al., 2010; Sanchez & Hueros, 2010; Escobar-Rodriguez & Monge-Lozano, 2012; Kilic, 2014; Abu-Shanab & Ababneh, 2015; Chung & Ackerman, 2015; Ros et al., 2015). Also, in this study, PU positively affects BIU of a learning management system (Hypothesis 1).

The effect of PEOU on PU of a learning management system is found significant in most studies (Davis, 1986, 1989, 1993; Davis et al., 1989; Liu et al., 2010; Chung & Ackerman, 2015; Venkatesh & Davis, 1996; Sanchez & Hueros, 2010; Kilic 2014; Ros et al., 2015) but is found not significant in some researches (Bajaj & Nidumolu, 1998; Escobar-Rodriguez & Monge-Lozano, 2012). In this study, PEOU positively affects the PU of a learning management system (Hypothesis 2).

The effect of PEOU on BIU a learning management system is mostly found significant in studies (Davis, 1986, 1989, 1993; Davis et al., 1989; Liu et al., 2010; Escobar-Rodriguez & Monge-Lozano, 2012; Venkatesh & Davis, 1996; Sanchez & Hueros, 2010; Kilic 2014; Abu-Shanab & Ababneh, 2015) and is not found significant in some research (Bajaj & Nidumolu, 1998; Ros et al., 2015). Also, in this study, PEOU positively affects BIU a learning management system (Hypothesis 4).

The effect of SN on BIU a learning management system is found significant in some studies (Park, 2009; Tarhini et al., 2013; Tarhini et al., 2014; Acarli & Saglam, 2015; Kurfali et al., 2017) but is not found significant in the study of Tosuntas et al. (2015). Also, in this study, SN positively affects BIU a learning management system (Hypothesis 6).

The effect of SN on PU of a learning management system is found significant in the study of Acarli and Saglam (2015) but is not found significant in the study of Park (2009). Also, SN positively affects PU of a learning management system (Hypothesis 7).

The effect of UID on PU of a learning management system is found significant in the study of Mouakket and Bettayeb (2015) and also, in this study, UID positively affects PU of a learning management system (Hypothesis 10).



The effect of UID on PEOU of a learning management system is found significant in the study of Liu et al. (2010) and also, in this study, UID positively affects the PEOU of a learning management system (Hypothesis 11).

The effect of CSE on PEOU of a learning management system is found significant in some researches (Venkatesh & Davis, 1996; Teo et al., 2012; Kilic, 2014) but is not found significant in the study of Sanchez and Hueros (2010). Also, in this study, CSE positively affects PEOU of a learning management system (Hypothesis 14).

The other eight hypotheses, rejected due to deletion of POLE, PI and CPWS, are listed below.

The effect of PEOU on PI with a learning management system is found significant (Liu et al., 2010; Ros et al., 2015) but in this study, PEOU does not positively affect PI with a learning management system (Hypothesis 3).

The effect of PI on BIU a learning management system is found significant (Liu et al., 2010; Ros et al., 2015) but in this study, PI does not positively affect BIU a learning management system (Hypothesis 5).

The effect of CPWS on BIU a learning management system is not found significant (Karahanna et al., 2006) and also, in this study, CPWS does not positively effect on BIU online learning system (Hypothesis 8).

The effect of CPWS on PU of a learning management system is found significant in some studies (Karahanna et al., 2006; Iglesias-Pradas et al., 2014) but not found significant in the study of Escobar-Rodriguez and Monge-Lozano (2012). Also, in this study, CPWS does not positively effect on PU of a learning management system (Hypothesis 9).

The effect of UID on PI of a learning management system is found significant in the study of Liu et al. (2010) but in this study, UID does not positively affect PI of a learning management system (Hypothesis 12).

The effect POLE on PU of a learning management system is found significant in some studies (Karahanna et al., 2006; Liu et al., 2010) but is not found in recent studies (Iglesias-Pradas et al., 2014; Ros et al., 2015). Also, in this study, POLE does not positively affect PU of a learning management system (Hypothesis 16).

The effect POLE on PEOU of a learning management system is found significant in some studies (Venkatesh & Davis, 1996; Bajaj & Nidumolu, 1998; Karahanna et al., 2006; Liu et al., 2010) but is not found in recent studies (Iglesias-Pradas et al., 2014; Ros et al., 2015). Also, in this study, POLE does not positively affect PEOU of a learning management system (Hypothesis 17).

The effect POLE on BIU a learning management system is found significant in some studies (Karahanna et al., 2006; Liu et al., 2010) but is not found in recent study of Ros et al. (2015). Also, in this study, POLE does not positively affect BIU a learning management system.

After the SEM analysis, it is seen that CSE badly affect TAM model and some hypotheses are removed as listed:

The effect of CSE on PU of a learning management system is found significant in some researches (Teo et al., 2012; Kilic, 2014; Mouakket & Bettayeb, 2015) but is not found significant in the study of Sanchez and Hueros (2010). Also, in this study, CSE is not positively affect Perceived Usefulness of a learning management system (Hypothesis 13).

The effect of CSE on BIU a learning management system is found significant in the study of Teo et al. (2012) but in this study, CSE is not positively affect BIU a learning management system (Hypothesis 15).

Finally, the study contributes the literature by testing the most common nine factors all at the same time. Also, the data was collected from two different samples to check whether there is a difference between them or not. After the analysis, it is found that six factors are relevant and there is no difference between two samples.

## 6.2 Limitations of the study

First limitation is about data collection. Most people do not want to fill online surveys. Thus, in Bilgi University, the questionnaires were distributed as hardcopy. Also, the data collection in Boğaziçi University was not easy. Sending the questionnaire link was worthless and resulted in waste of time. Thus, due to the time constraint, the data was needed to be collected in a short time. With the help of personal and family efforts, the surveys were filled out as hardcopy at South Campus of Boğaziçi University.

Another limitation of this study can be the usage of LMS. In Bilgi University, all courses are given on LMS but in Boğaziçi University, all courses are not. Thus, in Boğaziçi University, some users use LMS only to download the materials. Maybe, it is the same for Bilgi University. As a result, this condition has affected the study negatively.

### 6.3 Suggestions for future work

The framework of the study is big and some of external factors are deleted. Maybe, this is because two different samples are chosen and their background of using LMS is different. The future researches should add some extra questions to the questionnaire to understand the background of users such as the usage rate of functionalities of LMS.

Also, whole framework can be applied to a population who often uses functionalities of LMS to see whether the problem arises from sample's background or not.

Like the other studies (Liu et al., 2010; Escobar-Rodriguez & Monge-Lozano, 2012; Ros et al., 2015; Mouakket & Bettayeb, 2015; Abdullah & Ward, 2016; Sezgin & Ozkan-Yildirim, 2016; Kurfali et al., 2017), the future research can find other factors to affect the behavioral intention to use LMS.

APPENDIX A  
QUESTIONNAIRE

Survey about Usage of Learning Management Systems

This questionnaire is being performed in the concept of Boğaziçi University, Management Information Systems Department master's student Müyesser Eraslan Yalçın's master's thesis which has a topic as "Students' Acceptance of and Intention of Learning Management Systems using Extended TAM" with consultation of Prof. Dr. Birgül Kutlu Bayraktar. It will take approximately 10 minutes to answer this questionnaire. Your answers will be completely anonymous. Thank you for taking the time.

**\* Required**

### Personal Information

---

1. **University Name:** \*

---

2. **Department Name:** \*

---

3. **Education**

**Level:** \* *Mark*

*only one oval.*

- Undergraduate  
 MA  
 PHD

4. **Year of study in the university:** \* *Mark only one oval.*

- Preparation  
 First Year  
 Second Year  
 Third Year  
 Fourth Year or more

5. **Your Gender:**

*\* Mark only one oval.*

- Male  
 Female

6. **Your Age: \***

*Mark only one oval.*

- 18-20
- 21-23
- 24-26
- 27-29
- 30 or more

## **Questions about Learning Management Systems (LMSs)**

---

7. **Write the name of LMS you use: \***

\_\_\_\_\_

8. **Please indicate the level of your experience for the followings: \* Mark only one oval per row.**

	Never	Rarely	Sometimes	Often	Always
LMS Experience	<input type="radio"/>	<input type="radio"/>	<input type="radio"/>	<input type="radio"/>	<input type="radio"/>
Internet And Computer Experience	<input type="radio"/>	<input type="radio"/>	<input type="radio"/>	<input type="radio"/>	<input type="radio"/>

9. **Please indicate the number of Courses using LMS \* Mark only one oval per row.**

	1-2	3-4	5-6	7-8	9 or more
in previously semester	<input type="radio"/>	<input type="radio"/>	<input type="radio"/>	<input type="radio"/>	<input type="radio"/>
in this semester	<input type="radio"/>	<input type="radio"/>	<input type="radio"/>	<input type="radio"/>	<input type="radio"/>

**10. Your Usage of LMS per day \***

*Mark only one oval.*

- less than 1 hour
- 1-2 hours
- 3-4 hours
- 5-6 hours
- 7 hours or more

**11. Please indicate the level of your agreement for the below statements related to LMS usage**

\*

*Mark only one oval per row.*

	Strongly Disagree	Disagree	Neutral	Agree	Strongly Agree
Given the chance, I intend to use LMS to do different things, from downloading lecture notes and participating in chat rooms to learning on the Web.	<input type="radio"/>	<input type="radio"/>	<input type="radio"/>	<input type="radio"/>	<input type="radio"/>
I predict I would use LMS in the next semester.	<input type="radio"/>	<input type="radio"/>	<input type="radio"/>	<input type="radio"/>	<input type="radio"/>
In general, I plan to use LMS frequently for my coursework and other activities in the next semester	<input type="radio"/>	<input type="radio"/>	<input type="radio"/>	<input type="radio"/>	<input type="radio"/>

**12. Please indicate the level of your agreement for the below statements related to LMS Usefulness \***

*Mark only one oval per row.*

	Strongly Disagree	Disagree	Neutral	Agree	Strongly Agree
Using LMS will allow me to accomplish learning tasks more quickly.	<input type="radio"/>	<input type="radio"/>	<input type="radio"/>	<input type="radio"/>	<input type="radio"/>
Using LMS will improve my learning performance.	<input type="radio"/>	<input type="radio"/>	<input type="radio"/>	<input type="radio"/>	<input type="radio"/>
Using LMS will make it easier to learn course content.	<input type="radio"/>	<input type="radio"/>	<input type="radio"/>	<input type="radio"/>	<input type="radio"/>
Using will increase my learning productivity.	<input type="radio"/>	<input type="radio"/>	<input type="radio"/>	<input type="radio"/>	<input type="radio"/>
Using LMS will enhance my effectiveness in learning.	<input type="radio"/>	<input type="radio"/>	<input type="radio"/>	<input type="radio"/>	<input type="radio"/>
This system helps me keep active and motivated as I can have LMS available in my work/leisure space.	<input type="radio"/>	<input type="radio"/>	<input type="radio"/>	<input type="radio"/>	<input type="radio"/>

**13. Please indicate the level of your agreement for the below statements related to LMS Ease of Use \***

*Mark only one oval per row.*

	Strongly Disagree	Disagree	Neutral	Agree	Strongly Agree
Learning to operate LMS is easy for me.	<input type="radio"/>	<input type="radio"/>	<input type="radio"/>	<input type="radio"/>	<input type="radio"/>
I find it easy to get LMS to do what I want it to do.	<input type="radio"/>	<input type="radio"/>	<input type="radio"/>	<input type="radio"/>	<input type="radio"/>
My interaction with LMS is clear and understandable.	<input type="radio"/>	<input type="radio"/>	<input type="radio"/>	<input type="radio"/>	<input type="radio"/>
It is easy for me to become skilful at using LMS.	<input type="radio"/>	<input type="radio"/>	<input type="radio"/>	<input type="radio"/>	<input type="radio"/>
I find LMS easy to use.	<input type="radio"/>	<input type="radio"/>	<input type="radio"/>	<input type="radio"/>	<input type="radio"/>
It is easy to get materials from LMS.	<input type="radio"/>	<input type="radio"/>	<input type="radio"/>	<input type="radio"/>	<input type="radio"/>

**14. Please indicate the level of your agreement for the below statements related to LMS Interaction \***

*Mark only one oval per row.*

	Strongly Disagree	Disagree	Neutral	Agree	Strongly Agree
I discuss relevant learning topics with others on the discussion board.	<input type="radio"/>	<input type="radio"/>	<input type="radio"/>	<input type="radio"/>	<input type="radio"/>
I send e-mails to others as a way of communicating.	<input type="radio"/>	<input type="radio"/>	<input type="radio"/>	<input type="radio"/>	<input type="radio"/>
In general, I think this LMS environment provides good opportunities for interaction with other users.	<input type="radio"/>	<input type="radio"/>	<input type="radio"/>	<input type="radio"/>	<input type="radio"/>



**15. Please indicate the level of your agreement for the below statements related to your Previous LMS Experience \***

*Mark only one oval per row.*

	Strongly Disagree	Disagree	Neutral	Agree	Strongly Agree
I will have a better knowledge of how to use LMS if a teacher or peer shows me how to use it first.	<input type="radio"/>	<input type="radio"/>	<input type="radio"/>	<input type="radio"/>	<input type="radio"/>
I will have a better knowledge of how to use LMS if there is an online utility to guide me.	<input type="radio"/>	<input type="radio"/>	<input type="radio"/>	<input type="radio"/>	<input type="radio"/>
I will have a better knowledge of how to use LMS if I have previously used any of LMSs.	<input type="radio"/>	<input type="radio"/>	<input type="radio"/>	<input type="radio"/>	<input type="radio"/>
I feel it would easier to operate the system if I had previous experience of using it.	<input type="radio"/>	<input type="radio"/>	<input type="radio"/>	<input type="radio"/>	<input type="radio"/>

**16. Please indicate the level of your agreement for the below statements related to User Interface Design of the LMS \***

*Mark only one oval per row.*

	Strongly Disagree	Disagree	Neutral	Agree	Strongly Agree
LMS layout is user-friendly.	<input type="radio"/>	<input type="radio"/>	<input type="radio"/>	<input type="radio"/>	<input type="radio"/>
LMS layout is in good structure.	<input type="radio"/>	<input type="radio"/>	<input type="radio"/>	<input type="radio"/>	<input type="radio"/>
Overall, LMS user-interface design is satisfactory.	<input type="radio"/>	<input type="radio"/>	<input type="radio"/>	<input type="radio"/>	<input type="radio"/>
The layout design of the LMS makes it easy to read.	<input type="radio"/>	<input type="radio"/>	<input type="radio"/>	<input type="radio"/>	<input type="radio"/>

**17. Please indicate the level of your agreement for the below statements related to Social Norm of the LMS \***

*Mark only one oval per row.*

	Strongly Disagree	Disagree	Neutral	Agree	Strongly Agree
My Instructors think that it is important to use LMS.	<input type="radio"/>	<input type="radio"/>	<input type="radio"/>	<input type="radio"/>	<input type="radio"/>
Other students think that it is important to use LMS.	<input type="radio"/>	<input type="radio"/>	<input type="radio"/>	<input type="radio"/>	<input type="radio"/>
My friends think that it is important to use LMS.	<input type="radio"/>	<input type="radio"/>	<input type="radio"/>	<input type="radio"/>	<input type="radio"/>

**18. Please indicate the level of your agreement for the below statements related to LMS Task Compatibility \***

*Mark only one oval per row.*

	Strongly Disagree	Disagree	Neutral	Agree	Strongly Agree
Using LMS is compatible with my study.	<input type="radio"/>	<input type="radio"/>	<input type="radio"/>	<input type="radio"/>	<input type="radio"/>
Using LMS fits well with my personal, academic and professional development needs.	<input type="radio"/>	<input type="radio"/>	<input type="radio"/>	<input type="radio"/>	<input type="radio"/>
I think that using LMS fits well with the way I like to study.	<input type="radio"/>	<input type="radio"/>	<input type="radio"/>	<input type="radio"/>	<input type="radio"/>

**19. Please indicate the level of your agreement for the below statements related to LMS Self- Efficacy \***

*Mark only one oval per row.*

	Strongly Disagree	Disagree	Neutral	Agree	Strongly Agree
I can access the contents of LMS.	<input type="radio"/>	<input type="radio"/>	<input type="radio"/>	<input type="radio"/>	<input type="radio"/>
I can freely navigate the contents of LMS.	<input type="radio"/>	<input type="radio"/>	<input type="radio"/>	<input type="radio"/>	<input type="radio"/>
I can use LMS without needing to be told how it functions.	<input type="radio"/>	<input type="radio"/>	<input type="radio"/>	<input type="radio"/>	<input type="radio"/>
I can solve problems that arise on LMS.	<input type="radio"/>	<input type="radio"/>	<input type="radio"/>	<input type="radio"/>	<input type="radio"/>
I can use LMS if there are user manuals available.	<input type="radio"/>	<input type="radio"/>	<input type="radio"/>	<input type="radio"/>	<input type="radio"/>
Overall, I am able to use LMS.	<input type="radio"/>	<input type="radio"/>	<input type="radio"/>	<input type="radio"/>	<input type="radio"/>

APPENDIX B

RELIABILITY ANALYSIS OUTPUTS

Table B1. Reliability Analysis for BIU Scale

	Scale Mean if Item Deleted	Scale Variance if Item Deleted	Corrected Item-Total Correlation	Cronbach's Alpha if Item Deleted
BIU1	7.61	3.704	0.388	0.810
BIU2	7.32	2.980	0.633	0.522
BIU3	7.50	2.956	0.627	0.527

Table B2. Reliability Analysis for PU Scale

	Scale Mean if Item Deleted	Scale Variance if Item Deleted	Corrected Item-Total Correlation	Cronbach's Alpha if Item Deleted
PU1	17.91	15.806	0.705	0.899
PU2	17.97	15.088	0.813	0.883
PU3	17.70	15.727	0.708	0.898
PU4	17.96	15.045	0.790	0.886
PU5	17.96	15.184	0.789	0.887
PU6	18.09	15.011	0.691	0.903

Table B3. Reliability Analysis for PEOU Scale

	Scale Mean if Item Deleted	Scale Variance if Item Deleted	Corrected Item-Total Correlation	Cronbach's Alpha if Item Deleted
PEOU1	19.76	17.999	0.813	0.926
PEOU2	19.82	17.762	0.817	0.925
PEOU3	19.74	17.901	0.845	0.922
PEOU4	19.90	17.744	0.815	0.926
PEOU5	19.78	17.460	0.849	0.921
PEOU6	19.56	18.987	0.743	0.934

Table B4. Reliability Analysis for PI Scale

	Scale Mean if Item Deleted	Scale Variance if Item Deleted	Corrected Item-Total Correlation	Cronbach's Alpha if Item Deleted
PI1	5.47	4.798	0.643	0.767
PI2	5.27	4.203	0.682	0.730
PI3	5.08	4.730	0.675	0.736

Table B5. Reliability Analysis for SN Scale

	Scale Mean if Item Deleted	Scale Variance if Item Deleted	Corrected Item-Total Correlation	Cronbach's Alpha if Item Deleted
SN1	6.81	3.906	0.652	0.900
SN2	7.11	3.291	0.822	0.749
SN3	7.13	3.156	0.787	0.782

Table B6. Reliability Analysis for CPWS Scale

	Scale Mean if Item Deleted	Scale Variance if Item Deleted	Corrected Item-Total Correlation	Cronbach's Alpha if Item Deleted
CPWS1	7.20	2.758	0.735	0.831
CPWS2	7.30	2.281	0.788	0.773
CPWS3	7.35	2.292	0.732	0.830

Table B7. Reliability Analysis for UID Scale

	Scale Mean if Item Deleted	Scale Variance if Item Deleted	Corrected Item-Total Correlation	Cronbach's Alpha if Item Deleted
UID1	10.54	6.321	0.798	0.868
UID2	10.49	6.329	0.784	0.873
UID3	10.52	5.980	0.812	0.863
UID4	10.42	6.543	0.734	0.891

Table B8. Reliability Analysis for CSE Scale

	Scale Mean if Item Deleted	Scale Variance if Item Deleted	Corrected Item-Total Correlation	Cronbach's Alpha if Item Deleted
CSE1	19.08	11.378	0.649	0.789
CSE2	19.32	10.474	0.698	0.774
CSE3	19.28	10.417	0.669	0.779
CSE4	19.66	10.340	0.583	0.801
CSE5	19.54	11.623	0.386	0.843
CSE6	18.90	11.261	0.638	0.789

Table B9. Reliability Analysis for POLE Scale

	Scale Mean if Item Deleted	Scale Variance if Item Deleted	Corrected Item-Total Correlation	Cronbach's Alpha if Item Deleted
POLE1	10.88	5.940	0.567	0.794
POLE2	10.71	5.858	0.641	0.755
POLE3	10.42	6.159	0.651	0.751
POLE4	10.33	6.193	0.663	0.747

APPENDIX C

GROUP DIFFERENCES ABOUT BIU AN LMS

Table C1. T-test for Gender Differences on BIU an LMS  
Independent Samples Test

BIU	Levene's Test for Equality of Variances		t-test for Equality of Means						
	F	Sig.	t	df	Sig. (2-tailed)	Mean Difference	Std. Error Difference	95% Confidence Interval of the Difference	95% Confidence Interval of the Difference
								Lower	Upper
1*	0.595	0.441	-2.288	280	0.023	-0.22927	0.10019	-0.4265	-0.03204
2*			-2.317	27.321	0.021	-0.22927	0.09893	-0.42404	-0.0345

Note: 1\*=Equal variances assumed and 2\* = Equal variances not assumed

Table C2. T-test for University Differences on BIU an LMS  
Independent Samples Test

BIU	Levene's Test for Equality of Variances		t-test for Equality of Means						
	F	Sig.	t	df	Sig. (2-tailed)	Mean Difference	Std. Error Difference	95% Confidence Interval of the Difference	95% Confidence Interval of the Difference
								Lower	Upper
1*	1.842	0.176	0.781	280	0.435	0.07893	0.10101	-0.11992	0.27777
2*			0.796	274.879	0.427	0.07893	0.09918	-0.11633	0.27418

Note: 1\*=Equal variances assumed and 2\* = Equal variances not assumed

Table C3. T-test for LMS Differences on the Behavioral Intention to Use an LMS  
Independent Samples Test

BIU	Levene's Test for Equality of Variances		t-test for Equality of Means						
	F	Sig.	t	df	Sig. (2-tailed)	Mean Difference	Std. Error Difference	95% Confidence Interval of the Difference	95% Confidence Interval of the Difference
								Lower	Upper
1*	1.491	0.223	0.429	280	0.668	0.0433	0.10082	-0.15517	0.24176
2*			0.436	277.286	0.663	0.0433	0.09935	-0.15228	0.23887

Note: 1\*=Equal variances assumed and 2\* = Equal variances not assumed

APPENDIX D  
SEM ANALYSIS OUTPUTS

Table D1. Factor Loadings for Measurement Model

Factor	Estimate	Factor	Estimate
BI1	0.453	SN1	0.703
BI2	0.759	SN2	0.926
BI3	0.880	SN3	0.879
PU1	0.748	CPWS1	0.832
PU2	0.858	CPWS2	0.860
PU3	0.749	CPWS3	0.805
PU4	0.841	UID1	0.855
PU5	0.839	UID2	0.854
PU6	0.727	UID3	0.858
PEOU1	0.839	UID4	0.777
PEOU2	0.851	CSE1	0.768
PEOU3	0.876	CSE2	0.773
PEOU4	0.853	CSE3	0.737
PEOU5	0.877	CSE4	0.625
PEOU6	0.777	CSE5	0.392
POLE1	0.500	CSE6	0.754
POLE2	0.576	PI1	0.719
POLE3	0.877	PI2	0.770
POLE4	0.868	PI3	0.821



Table D2. Assessment of Normality for Measurement Model

Item	skew	c.r.	kurtosis	c.r.
POLE4	-0.916	-6.279	0.932	3.195
POLE3	-0.840	-5.760	0.857	2.938
POLE2	-0.592	-4.060	-0.145	-0.496
POLE1	-0.416	-2.854	-0.606	-2.077
CSE6	-1.201	-8.231	2.362	8.098
CSE5	-0.663	-4.546	0.262	0.899
CSE4	-0.448	-3.069	-0.221	-0.758
CSE3	-0.763	-5.231	0.418	1.434
CSE2	-0.608	-4.171	0.122	0.417
CSE1	-0.796	-5.456	1.472	5.047
UID4	-0.789	-5.410	0.608	2.084
UID3	-0.737	-5.052	0.205	0.703
UID2	-0.651	-4.466	0.318	1.091
UID1	-0.702	-4.812	0.241	0.827
CPWS3	-0.599	-4.103	0.224	0.768
CPWS2	-0.599	-4.109	0.428	1.466
CPWS1	-0.712	-4.883	1.450	4.970
SN3	-0.352	-2.411	-0.439	-1.505
SN2	-0.274	-1.877	-0.331	-1.134
SN1	-0.678	-4.646	0.326	1.118
PI3	-0.081	-0.555	-0.979	-3.356
PI2	0.223	1.526	-1.165	-3.995
PI1	0.303	2.078	-1.025	-3.513
PEOU6	-1.229	-8.424	1.856	6.361
PEOU5	-0.866	-5.940	0.260	0.892
PEOU4	-0.905	-6.201	0.617	2.116
PEOU3	-1.003	-6.875	0.985	3.375
PEOU2	-0.924	-6.335	0.491	1.684
PEOU1	-0.963	-6.602	0.682	2.336
PU6	-0.307	-2.101	-0.447	-1.532
PU5	-0.321	-2.202	-0.136	-0.465
PU4	-0.312	-2.137	-0.250	-0.858
PU3	-0.778	-5.337	0.553	1.896
PU2	-0.351	-2.407	-0.225	-0.770
PU1	-0.626	-4.290	0.550	1.885
BI3	-0.778	-5.334	0.170	0.582
BI2	-1.055	-7.232	0.816	2.797
BI1	-0.586	-4.017	-0.106	-0.364

Model Fit Summary for Measurement Model

Table D3. CMIN

Model	NPAR	CMIN	DF	P	CMIN/DF
Default model	110	1127.175	593	.000	1.901
Saturated model	703	0.000	0		
Independence model	37	7686.648	666	.000	11.542

Table D4. RMR, GFI

Model	RMR	GFI	AGFI	PGFI
Default model	0.060	0.818	0.784	0.690
Saturated model	0.000	1.000		
Independence model	0.331	0.163	0.116	0.154

Table D5. Baseline Comparisons

Model	NFI Delta1	RFI rho1	IFI Delta2	TLI rho2	CFI
Default model	0.853	0.835	0.925	0.915	0.924
Saturated model	1.000		1.000		1.000
Independence model	0.000	0.000	0.000	0.000	0.000

Table D6. Parsimony-Adjusted Measures

Model	PRATIO	PNFI	PCFI
Default model	0.890	0.760	0.823
Saturated model	0.000	0.000	0.000
Independence model	1.000	0.000	0.000

Table D7. NCP

Model	NCP	LO 90	HI 90
Default model	534.175	443.228	632.918
Saturated model	0.000	0.000	0.000
Independence model	7020.648	6741.790	7305.977

Table D8. FMIN

Model	FMIN	F0	LO 90	HI 90
Default model	4.011	1.901	1.577	2.252
Saturated model	0.000	0.000	0.000	0.000
Independence model	27.355	24.985	23.992	26.000

Table D9. RMSEA

Model	RMSEA	LO 90	HI 90	PCLOSE
Default model	0.057	0.052	0.062	0.016
Independence model	0.194	0.190	0.198	0.000

Table D10. AIC

Model	AIC	BCC	BIC	CAIC
Default model	1347.175	1381.578	1747.785	1857.785
Saturated model	1406.000	1625.868	3966.261	4669.261
Independence model	7760.648	7772.220	7895.399	7932.399

Table D11. ECVI

Model	ECVI	LO 90	HI 90	MECVI
Default model	4.794	4.471	5.146	4.917
Saturated model	5.004	5.004	5.004	5.786
Independence model	27.618	26.626	28.633	27.659

Table D12. HOELTER

Model	HOELTER .05	HOELTER .01
Default model	163	169
Independence model	27	28

## REFERENCES

- Abdullah, F., & Ward, R. (2016). Developing a general extended technology acceptance model for e-learning (GETAMEL) by analyzing commonly used external factors. *Computers in Human Behavior*, 56 (2016), 238-256.
- Abu-Shanab, E., & Ababneh, L. (2015). Exploring academicians acceptance of e-learning using an extended TAM: The case of Yarmouk University. *Journal of Network Communications and Emerging Technologies (JNCET)*, 1(1), 1-5. Retrieved from <http://www.jncet.org/Manuscripts%5CVolume-1%5CIssue-1%5CVol-1-issue-1-M-01.pdf>.
- Acarli, D. S., & Saglam, Y. (2015). Investigation of pre-service teachers' intentions to use of social media in teaching activities within the framework of technology acceptance model. *Procedia-Social and Behavioral Sciences*, 176(0), 709-713.
- Alias, N. A., & Zainuddin, A. M. (2005). Innovation for better teaching and learning: adopting the learning management system. *Malaysian Online Journal of Instructional Technology*, 2(2), 27-40.
- Arkorful, V., & Abaidoo, N. (2015). The role of e-learning, advantages and disadvantages of its adoption in higher education. *International Journal of Instructional Technology and Distance Learning*, 12(1), 29-42.
- Bajaj, A., & Nidumolu, S. R. (1998). A feedback model to understand information system usage. *Information & Management*, 33(4), 213-224.
- Black, E. W., Beck, D., Dawson, K., Jinks, S., & DiPietro, M. (2007). Considering implementation and use in the adoption of an LMS in online and blended learning environments. *TechTrends*, 51(2), 35-53.
- Brown, A. W., & Booch, G. (2002, April). *Reusing open-source software and practices: the impact of open-source on commercial vendors*. In software reuse: methods, techniques, and tools. Paper presented at International Conference on Software Reuse (pp. 123-136). Springer, Berlin, Heidelberg.
- Byrne, B. M. (2010). *Structural equation modeling with AMOS, basic concepts, applications, and programming* (2nd edition). New York: Routledge Taylor & Francis Group.

- Capper, J. (2001). E-learning growth and promise for the developing world. *TechKnowLogia*, 2(2), 7-10.
- Cheng, E. W. (2001). SEM being more effective than multiple regression in parsimonious model testing for management development research. *Journal of Management Development*, 20(7), 650-667.
- Chung, C., & Ackerman, D. (2015). Student reactions to classroom management technology: Learning styles and attitudes toward Moodle. *Journal of Education for Business*, 90(4), 217-223.
- Davis, F. D. (1989). Perceived usefulness, perceived ease of use, and user acceptance of information technology. *MIS Quarterly*, 13(3), 319-340.
- Davis, F. D. (1993). User acceptance of information technology: System characteristics, user perceptions and behavioral impacts. *International Journal Of Man-Machine Studies*, 38(3), 475-487.
- Davis, F. D., Bagozzi, R. P., & Warshaw, P. R. (1989). User acceptance of computer technology: A comparison of two theoretical models. *Management Science*, 35(8), 982-1003.
- Escobar-Rodriguez, T., & Monge-Lozano, P. (2012). The acceptance of Moodle technology by business administration students. *Computers & Education*, 58(4), 1085-1093.
- Fuggetta, A. (2003). Open source software—an evaluation. *Journal of Systems and Software*, 66(1), 77-90.
- Gautreau, C. (2011). Motivational factors affecting the integration of a learning management system by faculty. *Journal Of Educators Online*, 8(1), 1-25.
- Goncalves, A., & Pedro, N. (2012). Innovation, e-learning and higher education: An example of a University' LMS adoption process. In *WASET, Proceedings of the International Conference in Higher Education* (pp. 1075-1082). World Academy of Science, Engineering and Technology.

- Junior, J. H., Joseph, F., Anderson, R. E., & Tatham, R. L. (1992). *Multivariate data analysis with readings*. London: Macmillan.
- Hauge, O., Ayala, C., & Conradi, R. (2010). Adoption of open source software in software-intensive organizations—a systematic literature review. *Information and Software Technology*, 52(11), 1133-1154.
- Henley, M., & Kemp, R. (2008). Open source software: An introduction. *Computer Law & Security Review*, 24(1), 77-85.
- Iglesias-Pradas, S., Hernandez-Garcia, A., & Fernandez-Cardador, P. (2014). How socially derived characteristics of technology shape the adoption of corporate Web 2.0 tools for collaboration. *Service Business*, 8(3), 465-478.
- Karahanna, E., Agarwal, R., & Angst, C. M. (2006). Reconceptualizing compatibility beliefs in technology acceptance research. *MIS Quarterly*, 30(4), 781-804.
- Kilic, E. (2014). Determining the factors of affecting the Moodle use by using TAM. The story of a university after a destructive earthquake. *Hacettepe Üniversitesi Eğitim Fakültesi Dergisi*, 29(1), 169-179.
- Kurfali, M., Arifoglu, A., Tokdemir, G., & Pacin, Y. (2017). Adoption of e-government services in Turkey. *Computers in Human Behavior*, 66(2017), 168-178.
- Lederer, A. L., Maupin, D. J., Sena, M. P., & Zhuang, Y. (2000). The technology acceptance model and the World Wide Web. *Decision Support Systems*, 29(3), 269-282.
- Liaw, S. S. (2008). Investigating students' perceived satisfaction, behavioral intention, and effectiveness of e-learning: A case study of the Blackboard system. *Computers & Education*, 51(2), 864-873.
- Liaw, S. S., & Huang, H. M. (2013). Perceived satisfaction, perceived usefulness and interactive learning environments as predictors to self-regulation in e-learning environments. *Computers & Education*, 60(1), 14-24.

- Liu, I. F., Chen, M. C., Sun, Y. S., Wible, D., & Kuo, C. H. (2010). Extending the TAM model to explore the factors that affect intention to use an online learning community. *Computers & Education, 54*(2), 600-610.
- Mahnegar, F. (2012). Learning management system. *International Journal of Business and Social Science, 3*(12), 144-150.
- Momani, A., Emad, A. S., & Ababneh, N. (2012). E-learning systems' acceptance: The case of Eduwave In Jordan. In *The International Scientific Conference eLearning and Software for Education* (Vol. 2, p. 463-467). Carol I National Defence University.
- Mouakket, S., & Bettayeb, A. M. (2015). Investigating the factors influencing continuance usage intention of Learning management systems by university instructors: The Blackboard system case. *International Journal of Web Information Systems, 11*(4), 491-509.
- Naveh, G., Tubin, D., & Pliskin, N. (2010). Student LMS use and satisfaction in academic institutions: The organizational perspective. *The Internet and Higher Education, 13*(3), 127-133.
- Park, S. Y. (2009). An analysis of the technology acceptance model in understanding university students' behavioral intention to use e-learning. *Journal of Educational Technology & Society, 12*(3), 150-162.
- Pifia, A. A. (2013). Learning management systems: a look at the big picture. In Y. Kats (Ed.), *Learning management systems and instructional design: Best practices in online education* (pp. 1-19). Hershey, PA: Information Science Research.
- Reisinger, Y., & Turner, L. (1999). Structural equation modeling with Lisrel: Application in tourism. *Tourism Management, 20*(1), 71-88.
- Rogers, E. (2003). *Diffusion of innovations* (5th ed.). New York: Free Press.
- Ros, S., Hernandez, R., Caminero, A., Robles, A., Barbero, I., Macia, A., & Holgado, F. P. (2015). On the use of extended TAM to assess students' acceptance and intent to use third-generation learning management systems. *British Journal of Educational Technology, 46*(6), 1250-1271.

- Raubenheimer, J. (2004). An item selection procedure to maximize scale reliability and validity. *SA Journal of Industrial Psychology*, 30(4), 59-64.
- Sanchez, R. A., & Hueros, A. D. (2010). Motivational factors that influence the acceptance of Moodle using TAM. *Computers in Human Behavior*, 26(6), 1632-1640.
- Selim, H. M. (2007). Critical success factors for e-learning acceptance: Confirmatory factor models. *Computers & Education*, 49(2), 396-413.
- Sezgin, E., & Ozkan-Yildirim, S. (2016). A cross-sectional investigation of acceptance of health information technology: A nationwide survey of community pharmacists in Turkey. *Research in Social and Administrative Pharmacy*, 12(6), 949-965.
- Tarhini, A., Hone, K., & Liu, X. (2013). Factors affecting students' acceptance of e-learning environments in developing countries: A structural equation modeling approach. *International Journal of Information and Education Technology*, 3(1), 54-59.
- Tarhini, A., Hone, K., & Liu, X. (2014). Measuring the moderating effect of gender and age on e-learning acceptance in England: A structural equation modeling approach for an extended technology acceptance model. *Journal of Educational Computing Research*, 51(2), 163-184.
- Teo, T., Ursavas, O. F., & Bahcekapili, E. (2012). An assessment of pre-service teachers' technology acceptance in Turkey: A structural equation modeling approach. *The Asia-Pacific Education Researcher*, 21(1), 191-202.
- Tosuntas, S. B., Karadag, E., & Orhan, S. (2015). The factors affecting acceptance and use of interactive whiteboard within the scope of FATİH project: A structural equation model based on the unified theory of acceptance and use of technology. *Computers & Education*, 81(2), 169-178.
- Ursavas, O. F., Sahin, S., & McIlroy, D. (2014). Technology acceptance measure for teachers: T-TAM/öğretmenler için teknoloji kabul ölçeği: O-TKO. *Eğitimde Kuram ve Uygulama*, 10(4), 885-917.



Venkatesh, V., & Davis, F. D. (1996). A model of the antecedents of perceived ease of use: Development and test. *Decision Sciences*, 27(3), 451–481.

Wang, Y. S., Wang, H. Y., & Shee, D. Y. (2007). Measuring e-learning systems success in an organizational context: Scale development and validation. *Computers in Human Behavior*, 23(4), 1792-1808.

Yucel, U. A., & Gulbahar, Y. (2013). Technology acceptance model: A review of the prior predictors. *Ankara University Journal of Faculty of Educational Sciences*, 46(1), 89-109.

