

A NOVEL REPORT GENERATION APPROACH FOR MEDICAL  
APPLICATIONS: THE SISDS METHODOLOGY AND ITS APPLICATIONS

A THESIS SUBMITTED TO  
THE GRADUATE SCHOOL OF INFORMATICS INSTITUTE  
OF  
THE MIDDLE EAST TECHNICAL UNIVERSITY

BY

KAYA KURU

IN PARTIAL FULFILLMENT OF THE REQUIREMENTS FOR THE DEGREE OF  
DOCTOR OF PHILOSOPHY  
IN  
THE DEPARTMENT OF MEDICAL INFORMATICS

FEBRUARY 2010

Approval of the Graduate School of Informatics Institute.

---

Prof. Dr. Nazife Baykal  
Director

I certify that this thesis satisfies all the requirements as a thesis for the degree of Doctor of Philosophy.

---

Prof. Dr. Nazife Baykal  
Head of Department

This is to certify that we have read this thesis and that in our opinion it is fully adequate, in scope and quality, as a thesis for the degree of Doctor of Philosophy.

---

Assoc.Prof. Dr. Kürşat Çağiltay  
Co-Supervisor

---

Assoc. Prof. Dr. Kemal Arda  
Supervisor

Examining Committee Members

Prof. Dr. Ergun Karaağaoğlu (HACETTEPE) \_\_\_\_\_

Assoc. Prof. Dr. Kemal Arda (ONCOLOGY HOSP) \_\_\_\_\_

Assoc. Prof. Dr. Uğur Bozlar (GATA) \_\_\_\_\_

Prof. Dr. Bülent Celasun (GÖREN PATH) \_\_\_\_\_

Assist. Prof. Dr. Didem Gökçay (METU, II) \_\_\_\_\_

I hereby declare that all information in this document has been obtained and presented in accordance with academic rules and ethical conduct. I also declare that, as required by these rules and conduct, I have fully cited and referenced all material and results that are not original to this work.

Name, Last name : Kaya KURU

Signature :

# ABSTRACT

A NOVEL REPORT GENERATION APPROACH FOR MEDICAL APPLICATIONS:  
THE SISDS METHODOLOGY AND ITS APPLICATIONS

KURU, Kaya

Ph.D., Department of Medical Informatics

Supervisor: Assoc. Prof. Dr. Kemal Arda

Co-Supervisor: Assoc.Prof. Dr. Kürşat Çağiltay

February 2010, 174 pages

In medicine, reliable data are available only in a few areas and necessary information on prognostic implications is generally missing. In spite of the fact that a great amount of money has been invested to ease the process, an effective solution has yet to be found. Unfortunately, existing data collection approaches in medicine seem inadequate to provide accurate and high quality data, which is a prerequisite for building a robust and effective DDSS. In this thesis, many different medical reporting methodologies and systems which have been used up to now are evaluated; their strengths and deficiencies are revealed to shed light on how to set up an ideal medical reporting type. This thesis presents a new medical reporting method, namely “*Structured, Interactive, Standardized and Decision Supporting Method*” (SISDS) that encompasses most of the favorable features of the existing medical reporting methods while removing most of their deficiencies such as inefficiency and cognitive overload as well as introducing and promising new advantages. The method enables professionals to produce multilingual medical reports much more efficiently than the existing approaches in a novel way by allowing free-text-like data entry in a structured form. The proposed method in this study is proved to be more effective in many perspectives, such as facilitating the complete and the accurate data collection process and providing opportunities to build DDSS without tedious pre-processing and data preparation steps, mainly helping health care professionals

practice better medicine.

Keywords: medical reporting, diagnostic decision support systems, hierarchical data entry, inline editing, classification

# ÖZ

## TIBBİ UYGULAMALAR İÇİN YENİ BİR RAPOR ÜRETİM YAKLAŞIMI: SISDS METODU VE UYGULAMALARI

KURU, Kaya

Doktora, Tıp Bilişimi Bölümü

Tez Yöneticisi: Doç. Dr. Kemal Arda

Ortak Tez Yöneticisi: Doç. Dr. Kürşat Çağiltay

Şubat 2010, 174 sayfa

Tıpta güvenilir veri sadece birkaç alanda mevcuttur ve tanısal çıkarımlar için gerekli bilgiler genelde eksiktir. Süreci kolaylaştırmak için önemli miktarlarda paralar harcanmış olmasına rağmen, henüz tam olarak etkili bir çözüm bulunamamıştır. Maalesef, hâlihazır-  
daki veri toplama yaklaşımları tam ve yüksek kalitede verileri sağlama yönünden -ki bu konu güçlü ve etkili Tanısal Karar Destek Sistemleri (TKDS) için ön koşuldur- yetersizdir. Bu tezde, şimdiye kadar kullanılan tıbbi raporlama metotları ve uygulamaları değerlendirildi; nasıl bir ideal tıbbi raporlama çeşidinin oluşturulmasına ışık tutmak için onların güçlü ve zayıf taraflarının neler olduğu ortaya koyuldu. Bu tez, “Yapısal, Etkileşimli, Standartlaştırılmış ve Karar Destekleyici Metot (SISDS)” ismi verilen yeni bir tıbbi raporlama metodu önermektedir ki bu metot, mevcut raporlama metotlarının çoğu avantajlı özelliklerini kapsayan, bu metotların yetersizlik ve kavramsal yüklenme gibi dezavantajlarını ortadan kaldıran ve yeni bir takım özellikler sunan bir metottur. Metot, tıp çalışanlarının, hâlihazırdaki yaklaşımlara kıyasla çok daha etkili bir biçimde çok dilli tıbbi raporlar üretmelerine olanak sağlamak ve bunu serbest metin benzeri veriyi yapısal bir biçimde girmelerine olanak sağlayarak alışılmışın dışında bir yolla yapmaktadır. Önerilen yöntemin, tam ve doğru verilerin toplanması ile biktırıcı ön işlemler ve veri hazırlama adımları olmadan karar destek sistemlerinin

inşa edilebilmesi ile tıbbın çok daha iyi uygulanabilmesi gibi pek çok açıdan çok daha etkili olduğu görülmektedir.

Anahtar Kelimeler: tıbbi raporlama, tanısal karar destek sistemleri, hiyerarşik data girişi, metin içi yazım, sınıflandırma

# ACKNOWLEDGMENTS

First of all, my thanks go to my supervisor Dr. Kemal Arda for his continuous support and encouragement throughout my PhD years. I am furthermore grateful to Dr. Bülent Celasun, Dr. Ergun Karaağaoğlu, Dr. Kürşat Çağiltay and the members of the Informatics Institute at METU for their cooperation (especially Dr. Didem Gökçay and Dr. Nazife Baykal) and for generally improving my knowledge and PhD studies. Special thanks are due to Dr. Sertan Girgin from Computer Engineering Department at METU for his advices during the realization of the established method. I appreciated all the useful comments of reviewers at the conferences on Artificial Intelligence in Medicine (AIME'09) held in Italy and on Knowledge Science, Engineering and Management (KSEM'2009) held in Austria and during the publication phases. I am grateful to the radiology departments of six institutions that are Hacettepe Medical University, Medicana International Training and Research Hospital, Gülhane Military Medical Academy, Başkent University, Turkish Oncology Training and Research Hospital and Yüksek İhtisas Training and Research Hospital for providing the set of instances used in the study within the context of the ethic rules. I especially thank Dr. Ferhun Balkancı from Hacettepe University and Dr. Nazan Gökbayrak from Turkish Oncology Training and Research Hospital for their useful comments on the preparation of the esophagus report architecture that is used for data collection phase. I am also grateful to Dr. Barış Diren, Dr. Macit Arıyürek and Dr. Emin Alp Niron for their support during the data collection phase as being the head of their departments, and Dr. Uğur Bozlar for entering most of the instances in the system. Moreover, I have to express my gratitude to my manager, Colonel Gürcan Çiftlikoğlu, for his great support throughout my study. Last but not least I would like to thank my wife Arzu for her assistance throughout my education. To my sons, Kaan and newborn baby Kuzey, I thank them for understanding my frequent absences.



To My Family

# TABLE OF CONTENTS

ABSTRACT . . . . .	iv
ÖZ . . . . .	vi
ACKNOWLEDGMENTS . . . . .	viii
DEDICATON . . . . .	ix
TABLE OF CONTENTS . . . . .	x
LIST OF TABLES . . . . .	xiii
LIST OF FIGURES . . . . .	xv
LIST OF SYMBOLS . . . . .	xviii
CHAPTER	
1 INTRODUCTION . . . . .	1
1.1 Definition of Medical Reporting . . . . .	1
1.2 Problem Areas in Medical Reporting in General . . . . .	1
1.3 Significance of the Study . . . . .	4
1.4 Problem Statement Covered in the Thesis . . . . .	7
1.5 Organization of the Thesis . . . . .	8
1.6 Definition of Terms . . . . .	9
2 RELATED WORKS AND SOME ASPECTS OF MEDICAL REPORTING . . . . .	14
2.1 Some Early Systems in Medical Reporting . . . . .	15
2.2 Most Common Approaches in Medical Reporting . . . . .	21
2.3 Summary of the Analysis of the Related Works . . . . .	29
3 CONCEPTUAL UNDERSTANDING OF THE SISDS METHODOLOGY . . . . .	35
3.1 Some Essential Characteristics of an Effective Reporting Method . . . . .	36
3.2 Features of the SISDS Methodology . . . . .	40

4	DESIGN AND IMPLEMENTATION OF THE SISDS METHODOLOGY	49
4.1	Architectural Design of the Web-based Prototype . . . . .	49
4.2	System Requirements . . . . .	51
4.3	General Overview of the Established Methodology . . . . .	51
4.4	Design of the Features of the Methodology: Back-end . . . . .	52
4.5	Implementation of the Designed Features of the Methodology: Front-end .	61
5	EXPERIMENTAL RESULTS: EVALUATION AND TESTING OF THE SISDS METHODOLOGY	79
5.1	Preparation of a Questionnaire to Evaluate the SISDS Methodology . . . .	87
5.2	Evaluation of the Viability of the System by Field Experts with the Ques- tionnaire . . . . .	89
5.3	Evaluation of the System in terms of Building a DDSS . . . . .	90
5.4	Testing of the System's Real World Performance . . . . .	103
5.5	Summary of the Evaluation and the Testing of the SISDS Methodology . .	107
6	CONCLUSION	109
7	DISCUSSION	113
7.1	Limitations and Further Study . . . . .	115
	REFERENCES	118
	APPENDICES	125
A	RADIOLOGY ESOPHAGUS REPORT FORMAT APPLIED TO THE SISDS METHODOLOGY	125
B	A QUESTIONNAIRE TO EVALUATE THE ACCEPTANCE OF THE SISDS METHODOLOGY	147
C	THE ER DIAGRAM OF THE DATABASE	156
D	COMPARISON OF THE COMPLEXITY, VALUE, AND CHARACTERISTICS OF INFORMATION CAPTURE STYLES	158
E	THE INPUT ATTRIBUTE LIST USED IN BUILDING DDSS	161

F THE OUTPUT ATTRIBUTE LIST (ICD-10 DIAGNOSTIC CODES) USED IN BUILDING DDSS	166
G AN EXAMPLE OF DATA SET (INSTANCES) USED IN BUILDING DDSS	168
H THE AVERAGE RATES AND ACCURACIES OF THE CLASSIFICATION ALGORITHMS FOR K22.4 DIAGNOSIS	171
VITA . . . . .	174

# LIST OF TABLES

## TABLES

Table 2.1 General evaluation of the existing medical reporting approaches in terms of advantages and disadvantages . . . . .	33
Table 3.1 Formulas of definitions . . . . .	44
Table 3.2 Formulas of DRVDs . . . . .	45
Table 4.1 Syntax of variable, data entry/view definitions and trigger conditions . .	57
Table 5.1 Average results of the user evaluation questionnaire . . . . .	91
Table 5.2 Average accuracies of the classification algorithms for K22.4 diagnosis, .	96
Table 5.3 Average accuracies of the classification algorithms with parameter selection using information gain attribute evaluation (IG) and principal component analysis (PCA) . . . . .	97
Table 5.4 Average accuracies of the classification algorithms with bagging and bagging together with cost sensitive analysis for K22.4 diagnosis . . . . .	99
Table 5.5 Average accuracies of the classification algorithms for K22.4 diagnosis .	100
Table 5.6 Average accuracies of the classification algorithms for K22.4 diagnosis .	101
Table 5.7 A general evaluation of the questionnaire and the test of the SISDS methodology . . . . .	108
Table B.1 Question numbers in the questionnaire to measure the criterions . . . .	155
Table D.1 Complexity, Value, and Characteristics of Information Capture Styles . .	159
Table D.2 Information Capture Matrix . . . . .	160
Table H.1 Average rates and accuracies of the classification algorithms named ADTree and BayesNet . . . . .	172

Table H.2 Average rates and accuracies of the classification algorithms named Logistic and SMO . . . . .	173
--	-----

# LIST OF FIGURES

## FIGURES

Figure 2.1	An early computer reporting systems:The CLIP system . . . . .	16
Figure 2.2	An early computer reporting systems:The SCRIBE system . . . . .	17
Figure 2.3	Mark Sense Form RAPORT System . . . . .	20
Figure 2.4	An example for ASDCS Method . . . . .	27
Figure 2.5	An example for ASDCS Method, UltraStar . . . . .	29
Figure 3.1	An example of the hierarchical structure . . . . .	37
Figure 3.2	Elements and hierarchical structure of the formal specification of the SISDS method . . . . .	46
Figure 3.3	Interrelation among the layers of data, logic and presentation, and the user . . . . .	47
Figure 3.4	Diagram of Model-View-Controller . . . . .	48
Figure 4.1	Architecture of the Web-based prototype . . . . .	50
Figure 4.2	Header menu lists in all screens . . . . .	52
Figure 4.3	Screenshot of the user management task . . . . .	53
Figure 4.4	Screenshot to create new user or edit pre-created users . . . . .	53
Figure 4.5	User interface to define and edit a report . . . . .	55
Figure 4.6	User interface to define and edit a data group (question) . . . . .	56
Figure 4.7	Screen to filter collected data in accordance with some criterions to make research or to build DDSS . . . . .	59
Figure 4.8	Screen to add new departments . . . . .	59
Figure 4.9	Free text version of the same report in two languages . . . . .	60
Figure 4.10	An example of the definitions of report sections . . . . .	60
Figure 4.11	An example for the language mapping file . . . . .	62

Figure 4.12 Screenshot of the list of patients . . . . .	63
Figure 4.13 An example of the filter section to list the patients in several categories	64
Figure 4.14 Patient information screen for clinicians to order medical reports . . . . .	65
Figure 4.15 Interaction of the user with the front-end presentation layer to generate medical reports . . . . .	66
Figure 4.16 A split view approach having two separate data entry and report views to accomplish to compose an interactive medical reporting . . . . .	67
Figure 4.17 Inline data entry in free-text format . . . . .	68
Figure 4.18 Main Report Generation Page . . . . .	70
Figure 4.19 Screen to add diagnosis . . . . .	71
Figure 4.20 Screen of adding any kind of patient files . . . . .	71
Figure 4.21 Two different views of the same report . . . . .	72
Figure 4.22 An example of free-text view form for generated reports . . . . .	73
Figure 4.23 An example of structured nested and hierarchical view form of gener- ated reports . . . . .	74
Figure 4.24 Screen of user settings . . . . .	76
Figure 4.25 Screen of the questionnaire to evaluate the methods . . . . .	77
Figure 5.1 Initial skeleton of the esophagus report with normal values in free-text form . . . . .	80
Figure 5.2 Initial skeleton of the esophagus report with normal values as structured question/answer view . . . . .	81
Figure 5.3 Esophagus report with most of the triggered report-wide trigger condi- tions . . . . .	84
Figure 5.4 Esophagus report with most of the triggered report-wide trigger condi- tions as structured tabular nested list in Turkish . . . . .	85
Figure 5.5 Esophagus report with most of the triggered report-wide trigger condi- tions as structured tabular nested list in English . . . . .	86
Figure 5.6 Distribution of the data set . . . . .	94
Figure 5.7 An example to compose DDSS in the prototype for K21.9 . . . . .	94
Figure 5.8 Average classification accuracy with parameter selection using informa- tion gain attribute evaluation and principal component analysis . . . . .	98
Figure 5.9 Average accuracies of classification algorithms when applied to the data set . . . . .	99



Figure 5.10 Average classification accuracy of boosting together with information gain attribute evaluation and principal component analysis . . . . .	102
Figure 5.11 Screenshot of the SISDS method for generating medical reports . . . . .	105
Figure 5.12 Screenshot of the SISDS method for generating medical reports . . . . .	106
Figure B.1 An example for the questionnaire . . . . .	147
Figure C.1 ER diagram of the SISDS methodology . . . . .	157

# LIST OF SYMBOLS

<b>AHIMA</b>	American Health Information Management Association	<b>HIS</b>	Hospital Information System
<b>ASDCS</b>	All Structured Data Collected in a Screen	<b>HTML</b>	Hyper Text Markup Language
<b>BNF</b>	Backups Naur Form	<b>HW</b>	Hand Writing
<b>CLIP</b>	The Coded Language Information Processing	<b>IWONS</b>	Interactive Walk on Necessary Steps
<b>CPR</b>	The Computer-based Patient Record	<b>ICD</b>	International Classification of Diseases
<b>CPU</b>	The Central Processing Unit	<b>IG</b>	Information Gain
<b>CRT</b>	Cathode Ray Tube	<b>ISR</b>	Isolated speech recognition
<b>CSR</b>	Continuous Speech Recognition	<b>LDS</b>	Latter Day Saints Hospital
<b>CT</b>	Computed Tomography	<b>MARS</b>	Missouri Automated Radiology System
<b>CVS</b>	Comma Separated Values	<b>MCS</b>	Mid-Continent Computer Systems
<b>DB</b>	Database	<b>METU</b>	Middle East Technical University
<b>DBSR</b>	Dictation by Speech Recognition	<b>ML</b>	Machine Learning
<b>DICOM</b>	Digital Imaging and Communications in Medicine	<b>MRI</b>	Magnetic Resonance Imaging
<b>DSS</b>	Decision Support System	<b>MVC</b>	Model-View-Controller
<b>DDSS</b>	Diagnostic Decision Support System	<b>NLP</b>	Natural Language Processing
<b>DRVD</b>	Data Request/View Definitions	<b>PACS</b>	Picture Archiving and Communication Systems
<b>EHR</b>	Electronic Health Record	<b>PCA</b>	Principal Component Analysis
<b>EPSS</b>	Electronic Performance Support System	<b>RAM</b>	Read Access Memory
<b>GB</b>	Gigabyte	<b>RIS</b>	Radiology Information System
<b>GHz</b>	Gigahertz	<b>ROI</b>	Return On Investment
<b>GUI</b>	Graphical User Interface	<b>RSI</b>	Repetitive Stress Injury
		<b>RTAS</b>	The Automated Voice Recording Systems

**RTTOS** Real Time Transcriptionist-Oriented Systems

**SISDS** Structured, Interactive, Standardized, and Decision Supporting

**SNOMED** The Systematized Nomenclature of Medicine

**SMO** SVM implementation is called SMO

**SPSS** Statistical Package for the Social Sciences

**SVM** Support Vector Machine

**TA** Telephone Access

**TKDS** Tanısal Karar Desdek Sistemleri

**TNR** True Negative Rate

**TPR** True Positive Rate

**TOS** Transcriptionist-Oriented Systems

**UltraSTAR** Ultrasound Structured Attribute Reporting

**USD** United States Dolor

**WEKA** the Waikato Environment for Knowledge Analysis

# CHAPTER 1

## INTRODUCTION

### 1.1 Definition of Medical Reporting

A medical report can be defined as the results of a medical examination of a patient or a written document describing the findings of a patient. It provides physicians with a better diagnostic decision supporting ability and subsequently guides physicians through a better health care service for the patient. Medical reports are the primary means of communication between laboratory professionals and referring physicians. *The Computer-based patient record* (CPR) is moving from the notion of one location, one patient care event, one device to a much enhanced information utility for the care of patients including the ability to provide longitudinal account of care and an extension of medical knowledge (Lehmann et al., 2006). Medical reports constitute one of the main sources of medical knowledge.

### 1.2 Problem Areas in Medical Reporting in General

Originally, health care professionals recorded medical reports themselves on paper with specific authentication methods such as signatures in black ink. With emerging technologies and ever increasing need for accessibility and ease of use, the process of producing and distributing medical reports started to be computerized (Jost, 1986). Medical departments have made an effort to achieve a goal of collecting data in a structured format and some of the earliest attempts focused on developing custom computer terminals at which professionals could produce coded reports themselves (Jost, 1986). With time, the features that allowed professionals to produce reports based on coded input were used less and less (Waegemann et al., 2002). Bell et al. indicate that one major obstacle to the success of computer systems is that *physicians have difficulty in entering data* (D. S. Bell, Greenes, & Doubilet, 1992). In addition to that, the difficulty of reproducing or acquiring the information capture

technology for widespread use is hampered by *cost considerations*, *the lack of standardization* (Waegemann et al., 2002; Sim & Rennels, 1995) and *cognitive overload* (Sistrom, 2005; Garrod, 1998; Cimino & Patel, 2001) imposed by existing medical data entry approaches. The shortcomings of existing medical reporting approaches such as standardization, cost consideration, cognitive overload and some others are mentioned in the following paragraphs in detail.

There is a lack of standards and a lack of consensus on proposed standards in medicine. The standard coding systems upon which professionals or institutions compromised are very limited such as ICD-10 and SNOMED. Thus, the coding systems in terms of the medical terms used in some applications didn't gained widespread acceptance by other professionals or institutions. Without agreed upon standard coding system, healthcare professionals inclined to generate medical reports in free text form to be more flexible and to establish an unequivocal communication. In this manner, vast majority of providers are necessary to keep paper-based information systems for backup, as well as, tries to keep computer-based unstructured format (Waegemann et al., 2002). It is a reality that a large percentage of information in medical departments is unstructured, taking the form of free text, and is therefore difficult to search, sort, analyze, summarize, and present (Taira, Soderland, & Jakobovits, 2001). Medical reports are usually in unstructured format with equivocal abbreviations depending on the professionals, a large vocabulary, ungrammatical writing styles, many different codes and complex medical terms and furthermore incomplete since details are assumed to be *common knowledge* and left out (Taira et al., 2001). Therefore, decisions upon medical reports are prone to *medical errors* that cause many avoidable deaths. Moreover, *lack of quick dissemination of medical reports*, *suboptimal report quality and accuracy*, *and the unsuitability of report information for quality improvement, research and decision supporting* are some of the shortcomings of the conventional reporting. These shortcomings, as a result, require additional and in general tedious preprocessing steps to prepare the data for further analysis and use, as in the case of *diagnostic decision support systems* (DDSSs) and *research*.

In addition to the problems mentioned above, most of the early systems and common approaches currently used in medical reporting have many deficiencies as detailed in next Chapter 2, such as inefficiency and *cognitive overload*, which is an other cause of directing professionals towards generating medical reports in free-text style rather than structured and coded form. Cognitive overload seems one of the most important bottlenecks for the success of any medical system by which data are entered, processed (Sistrom, 2005; Garrod,

1998; Cimino & Patel, 2001) and viewed. During medical reporting, many windows remain open simultaneously having radio buttons, combo boxes, buttons and checkboxes to select concepts and in its use of multiple small windows, a cause for cognitive overload. One major obstacle to the success of computer systems is that physicians have difficulty in entering data (D. S. Bell et al., 1992). Systems difficult to generate medical reports are complex both visually and cognitively, as in the case of locating the cursor (cognitive focus) at the right dedicated section (combo boxes, text boxes, check boxes, radio buttons, etc.) on the screen among many complex predefined concepts. Cognitive load necessitates an extensive computer knowledge in design as well. Dependence to extensive computer knowledge for updates for the architecture of report formats have been the most effecting factor for structured reporting systems to be used less and less, thought, they have many advantages. A recent report by the Institute of Medicine in this respect lists *inadequate methods* for generating and relaying information as one of the several potential causes of medical errors (IOM, 2006).

Despite many years of research and millions of dollars of expenditure on medical diagnostic systems (Graber, Gordon, & Franklin, 1994) parallel to medical professionals' indication to a need for computer-aided diagnostic support systems (Graber et al., 1994), devices that may provide such support are not in widespread use and of all medication related errors about 60 - 70 percent occur on the stage of decision making (Wilson, McCartney, & Newcombe, 1998). Although some highly specialized programs are in routine use, many of the broad-based diagnostic programs are still not widely used, possibly because it is unclear how much they can assist professionals (Berner, 1999) and most possibly collected data are not sufficient in content and suitable to serve decision making. In addition to that, current diagnostic decision support applications are usually not including the most scientific observations in most of the current DSS. A very limited number of data are being generally examined, some of which as testing data and the remaining data as a training, and DSSs are being built depending on this examination, a major cause of DSSs not used and accepted as valid systems. However, DDS systems should augment reasoning by every new value in medical reporting and improve themselves automatically without needing extensive computer knowledge. Because, practices to cure diseases change, and the number and the diversity of diseases increases in a quicker pace now rather than that in the past. Furthermore, the implementation and complete integration of disease specific and patient specific DSS into implementations is challenging, because developers face both technical and behavioral problems that are difficult to overcome. Building DSSs in today's systems are depending on a high degree of computer expertise, a cause of high cost of building decision support systems

permanently including most recent data into the system.

In all sectors, technological diseases, a cause for concern where transcriptionists dictate huge number of medical reports using keyboard in reporting phase in free-text machine readable format either from speeches of professionals in real time or from speeches in speech recording devices, cost economies all around the world <sup>1</sup>. The approaches in medical reporting seem behind the available technology that could provide more abilities than that medical institutions have in hand.

The problem areas of medical reporting mentioned in previous paragraphs are the most common types as well as there are more other types in addition to these problems. More problems specific to the approaches are indicated in next Chapter 2.

### 1.3 Significance of the Study

Even though medical reports constitute one of the main sources of medical knowledge, reports are difficult to find, read, and apply to clinical care due to some difficulties, one of which is the lack of a common, standardized structure in medical reporting. A common complaint by laboratory professionals is that of inadequate information from clinicians requesting studies (Sistrom & Langlotz, 2005a; Dacher & Lechevallier, 1999; Gunderman, Phillips, & Cohen, 2001). Clinicians, on the other hand, express concerns that interpretations in medical reports are often not relevant to the clinical questions they seek to answer (Sistrom & Langlotz, 2005a; Sistrom, 2005). There is a need to improve the clarity of communication among laboratory professionals and referring physicians, and to improve the quality of laboratory professionals' and clinicians' interpretations. In many cases, laboratory professionals and referring physicians need to come together to accomplish an unequivocal communication for optimal outcomes (Sistrom, 2005), which is not an easy task in a crowded and sometimes chaotic atmosphere of hospitals. Unfortunately, current reporting methods are not sufficient in establishing the required communication medium (Sistrom, 2005). This leads to avoidable *medical errors* which cost both human life and substantial amount of money (DynamicChiropractic, 2004; IOM, 2006; Nosek, 2006) <sup>2</sup>. These errors could be re-

---

<sup>1</sup>Approximately 100 billion dollar for USA economy (Mogensen, 1999)

<sup>2</sup>Only in USA, more than 100.000 people die each year from medical errors (HealthGrades, 2004) with an estimated cost of 20 billion USD between 2000 and 2002 (DynamicChiropractic, 2004). We haven't encountered any study in the literature about how many people there are in a miserable living condition because of avoidable medical errors, although they are still living in spite of improper practices applied on them

duced and avoidable with more effective methodologies that help practitioners to practice better medicine.

DDSSs are computer programs that are designed to provide accurate and useful patient specific and situation specific advice and *assist* health professionals in making proper diagnosis at the point of care as a technological solution for the reduction of diagnostic errors in practice (Graber, Gordon, & Franklin, 2002). A DDSS would take the medical data and propose a set of appropriate diagnoses in terms of these data. However, developing a DDSS is a non-trivial task owing to the multitude of variables and complex relationship between them. A physician may be confronted with more than 200 variables in critical cases (A. Morris & Gardner, 1992). Early decision support systems such as Mycin and Internist were designed at academic medical institutions to assist physicians in the diagnosis and treatment of complex problems (Lehmann et al., 2006). However these early DDS systems were limited in scope and capabilities. As the clinical community learned more about how computers could play a role in communications and decision making, as programming tools became more robust, and as the price of hardware systems decreased, more broad-based applications were developed (Lehmann et al., 2006). Some of the most significant products were developed at Latter Day Saints Hospital (LDS), Regenstrief Institute, Brigham and Womens Hospital, Duke University Medical Center, and at Wanderbilt University Medical Center (Lehmann et al., 2006)<sup>3</sup>. Yet, these systems are not in widespread use.

One possible approach to build a DDSS is to define rule sets based on experts' opinion. Even though this approach may be feasible in certain cases, it has certain drawbacks and prone to errors. The volume of scientific information is growing exponentially. It is practically impossible for health care professionals to keep track of all relevant medical knowledge, and they have limited ability to deal effectively with large amounts of information. For instance, humans may not be able to develop a systematic response to any problem involving more than seven variables (Miller, 1999). Moreover, humans are limited in their ability to estimate the degree of relatedness between only two variables (Jennings, Amabile, & Ross, 1982). If it is for sure that there is a consensus about a diagnosis for some values entered for data entries, this knowledge can be defined into a computer application to be proposed when the right conditions occur as a ruled-based understanding. The prototype of the presented medical reporting system provides this kind of definitions and the SISDS method alerts as any specific condition succeeds. We may call the prototype system as an expert system

---

<sup>3</sup>See the book written by Lehmann et al. (2006) for more information about these decision supporting systems that are not widespread use.



in terms of this functionality by using a ruled-based understanding. However, rule-based systems are simpler and are descriptive rather than inferential from gained knowledge in that they reflect the biases and logical errors of human thinking. The process of knowledge acquisition often involves multiple experts and in some cases, groups of experts have different opinions or solutions. In those situations, one approach to deal with the different solutions is to choose the consensus position as the basis for the knowledge used in the system. Unfortunately, in some cases the consensus judgment is incorrect. Personal bias may distort an objective judgment. Furthermore, even agreement among the experts *does not always guarantee correctness* (Sorenson, Grove, & Selto, 1982) <sup>4</sup>. What's more, the problem with the rule-based systems is that in complex areas, the amount of knowledge is so vast that it is extremely difficult to absorb all of it in medical domains based on decision trees. Thus, constructing the rule set can be labor intensive. Therefore building an intelligent system using knowledge is not an easy issue, but indispensable. The process of constructing the knowledge base is dependent on knowledge acquisition. The original goal of knowledge-base systems was to capture physician knowledge of experts in their domain of expertise and to be able to reason using this knowledge. The acquisition of physician knowledge in real-time has been a major bottleneck in development of knowledge-base systems. This is one of the most important and most difficult steps of building a DDSS (Grzymala, Grzymala, & Grzymala, 1995). By automating the induction of general concepts or rules from available data, this bottleneck can be eased (Cunningham & Denize, 1994). In view of the difficulties in applying rule-based systems in areas of extensive knowledge, the solution as an alternative approach is to apply *machine learning* (ML), in particular *classification*, techniques to predict possible diagnoses automatically based on existing medical data, which has the potential to build more accurate and reliable models as we aim to establish in the methodology named SISDS that is proposed in this study.

Since the early days of medical reporting systems, there has been very little that has changed in the commercial products available for effective medical reporting. However, it is apparent that more recent technological advances should result in improved tools for data capture at the point of care (Lehmann et al., 2006). The difficulties that medical professionals face during medical reporting necessitate the use of new and *efficient* data collection and dissemination methods that would essentially *reduce the cognitive overload*. There is a need for better applications to generate medical reports in terms of the available technology that

---

<sup>4</sup>Empirically, researchers have found that experts in some domains have been correct only 40-60% of the time (Sorenson et al., 1982).

provides more abilities than that medical professionals have in hand. In this study, we aim to establish a better medical reporting approach than the most common and widespread approaches by taking into consideration of their advantages and shortcomings as well as including some more abilities that haven't been encompassed by them.

## 1.4 Problem Statement Covered in the Thesis

In this study, our main objective is to provide an alternative electronic data collection and dissemination methodology in the field of medical reporting that has an optimized reporting process and possesses a better decision supporting capability. The establishment of the novel methodology in this study depends on firstly the detail analysis of the previous and current approaches by revealing their strengths and deficiencies, failures and achievements of these approaches and secondly the expectations of the actors such as laboratory professionals, examining physicians, institutions, patients, government, health insurance companies, etc. in the medical field by encompassing their priorities into the methodology. In this perspective, the necessary features of an effective data collection and reporting system are presented. A novel method ensuring these features is aimed to be built. The method that is proposed in this study enables professionals to produce multilingual medical reports much more efficiently than existing approaches in a novel way by allowing free-text like data entry in a structured form by using an interactive interface. The interactivity with its versatile, user and problem-driven, scalable and dynamic reporting mechanism helps to avoid the inefficiency and the cognitive overload. Moreover, the proposed methodology is realized together with decision supporting ability in that the data collected by the methodology are used to put forward whether the data collected by using the proposed approach can be used effectively for designing DDSS without tedious data preprocessing steps. The methodology is evaluated and tested by medical professionals is several aspects. The evaluation of the implementation by professionals in real environment indicates its success as professionals seem to be eager to migrate from the existing approaches to a more satisfactory approach such as the one we propose.

We propose the “*Structured, Interactive, Standardized and Decision Supporting*” (SISDS) medical reporting method that encompasses most of the favorable features of existing medical reporting methods while trying to remove their deficiencies, such as inefficiency and cognitive overload. Moreover, it introduces and promises new advantages. SISDS is designed to be an *electronic performance-support system* (EPSS) that enhances the process of medical reporting

by improving the poor performance while providing decision supporting and just-in-time learning abilities to users. It enables an apprentice to perform properly at an expert's level with minimal cognitive effort, support and intervention by others.

The present methodology with some clues has the ability to show results reporting of normal and abnormal values during report generation as well as while writing final reports. Having this property, the present method calls attention to abnormal values and help physicians in their decisions. Furthermore, the SISDS methodology eases the establishment of accurate *diagnostic decision support systems* (DDSS) by avoiding tedious data preprocessing steps – a process that depends on two interrelated factors: the structure and the quality of the data, which directly depends on the reporting system being used, and the chosen machine learning method that suits the data best. In particular, we discuss the particular characteristics of the collected medical data and how it can be leveraged to improve the diagnostic predictions and then we deliver the results of the applied testbed of the SISDS method put into practice at several radiology departments to test the viability of the method. The feedbacks that we received from the users who evaluated SISDS alongside with other existing methods show that the proposed method is more effective in many perspectives mainly helping health care professionals practice better medicine.

## 1.5 Organization of the Thesis

The remainder of this thesis is organized as follows:

In Chapter 2, medical reporting is evaluated up to now by providing a detailed analysis of the different types of medical reporting methods to reveal the advantages and shortcomings of these reporting methods, together with some aspects of medical reporting. First, some of the earliest computerized medical reporting attempts focused on developing specialized and to some extent customized computer terminals at which professionals could produce reports themselves with predefined coded forms to reduce errors and increase health care services are evaluated. Secondly, various existing most common medical reporting methodologies are presented by including their shortcomings and advantages in terms of the actors who are related to generated medical reports such as laboratory professionals, physicians, patients, etc.. And, finally, a summary of deficiencies and superiorities of these approaches is given in a comparison to each other in a table.

In Chapter 3, we first discuss some necessary and essential features of an effective data collection and reporting system, and then reveal the conceptual understanding and formal

definition of a novel method named as the SISDS methodology that aims to encompass these features as well as the favorable features of most common approaches mentioned in the previous chapter. How medical reporting is benefited from structured, interactive, and standardized reporting and how decision supporting is eased is pointed out. Moreover, how the criterions of learning organization and EPSS for a system to be in a long life span is included in the methodology is presented.

In Chapter 4, how that the realization of the SISDS is employed is revealed. We built a Web-based prototype to check the usability and the benefits of SISDS approach and to verify what we suggested by applying SISDS to remove the deficiencies of current medical reporting systems. Firstly, an architectural design of the web-based prototype of the SISDS methodology is demonstrated. Secondly, system requirements and general overview of the established methodology are defined, followed by design of the back-end and the implementation of the front-end.

In Chapter 5, how knowledge obtained by previous standardized and coded information is utilized to propose possible diagnosis for successive report generation in the SISDS methodology is discussed. Several common machine learning algorithms, especially classification techniques together with some meta learning algorithms such as cost sensitive analysis, bagging, boosting, PCA, IG, etc. by 10-fold cross validation, are evaluated to find the best classifiers and how these classifiers are employed to trigger right diagnoses is revealed. Feedbacks about the different aspects of the methodology were collected from users by using a questionnaire that was prepared by field experts. Some different medical reporting methods including SISDS are compared to each other by this questionnaire. Moreover, the real world performance of the SISDS approach is tested in terms of some criterions in a comparison to most common approaches.

Chapter 6 discloses a general summary titled conclusion following a discussion with Chapter 7 including limitations and suggestions for future work.

## 1.6 Definition of Terms

**AJAX:** AJAX is a group of interrelated web development techniques used on the client-side to create interactive web applications: with Ajax, web applications can retrieve data from the server asynchronously in the background without interfering with the display and behavior of the existing page; the use of Ajax techniques has led to an increase in interactive or dynamic interfaces on web pages (Wikipedia, 2004a).

**Backus Naur Form (BNF) Notation:** In computer science, Backus Naur Form, BNF, is a metasyntax used to express context free grammars, that is, a formal way to describe formal languages (Wikipedia, 2005a). John Backus and Peter Naur developed a context free grammar to define the syntax of a programming language by using two sets of rules, lexical rules and syntactic rules (Wikipedia, 2005a). BNF is widely used as a notation for the grammars of computer programming languages, instruction sets and communication protocols, as well as a notation for representing parts of natural language grammars (Wikipedia, 2005a).

**Cognitive overload:** During medical reporting, many windows remain open simultaneously having radio buttons, combo boxes, buttons and checkboxes to select concepts and in its use of multiple small windows, a cause for cognitive overload. One major obstacle to the success of computer systems is that physicians have difficulty in entering data (D. S. Bell et al., 1992). Systems difficult to generate medical reports are complex both visually and cognitively, as in the case of locating the cursor (cognitive focus) at the right dedicated section (combo boxes, text boxes, check boxes, radio buttons, etc.) on the screen among many complex predefined concepts, as in the case of ASDCS.

**Comma-separated values (CSV) format:** A comma-separated values (CSV) file is used for the digital storage of data structured in a table of lists form, where each associated item (member) in a group is in association with others also separated by the commas of its set (Wikipedia, 2001). Each line in the CSV file corresponds to a row in the table; within a line, fields are separated by commas, each field belonging to one table column (Wikipedia, 2001). Since it is a common and simple file format, CSV files are often used for moving tabular data between two different computer programs, for example between a database program and a spreadsheet program (Wikipedia, 2001).

**Data Request/View Definitions (DRVD):** DRVDs are used by the presentation layer to render data entry forms or reports based on their type such as in nested tabular form, in textual report format or in different languages according to the request from the user. This gives rise to a unified view in which data collection and viewing are handled similarly.

**Digital Imaging and Communications in Medicine (DICOM):** DICOM is an Image Standard for Digital Communication usually used in medicine, especially in radiology. DICOM standard includes personal information of the patient, the doctor and the

related text information about the image such as time and the kind of the image captured.

**Electronic Health Record (EHR):** It is a record in digital format that is capable of being shared within across different health care settings (Wikipedia, 2005b). EHR records include a whole range of data in comprehensive or summary form, including demographics, medical history, medication and allergies, immunization status, laboratory test results, radiology images, and billing information (Wikipedia, 2005b).

**Electronic Performance Support System (EPSS):** An established system could be called as an EPSS if it is leading an apprentice through a task to perform at the expert's level without intervention by others by providing just-in-time learning abilities.

**Hospital Information Systems (HIS):** HIS is a system in which patients information is stored and managed via a network. It incorporates interrelated several modules depending on the hospital such as admission, accounting, discharging, laboratory.

**Interactively walking on the necessary steps:** Although the total number of possible realizations may be large in a medical reporting (due to the combinatorial expansion), by *interactively walking on the necessary steps* while completing the report, the number of data entries that need to be specified can be reduced considerably – a process which effectively corresponds to following a path on the hierarchy. Related and necessary information is displayed to the user by means of interactivity with the user to reduce cognitive overload.

**International Classification of Diseases (ICD):** The International Statistical Classification of Diseases and Related Health Problems 10th Revision (ICD-10) is a coding of over 155000 diseases and signs, symptoms, abnormal findings, complaints, social circumstances and external causes of injury or diseases (Wikipedia, 2005c).

**Lesion blindness:** The condition in which a medical professional could not see other pertinent details while concentrating on a specific subject (lesion, etc.). This term is generally used by radiologists and pathologists. “change blindness” is a similar and more general term that is used in psychology.

**Look-away problem:** It is caused by tasks other than examining patients or images that need to be done frequently, eg. in case of dictation, users that have to check what

is dictated and correct mistakes while generating reports are faced with a look-away problem.

**Model-View-Controller (MVC):** (MVC) is an architectural pattern used in software engineering. The pattern isolates "domain logic" (the application logic for the user) from input and presentation (GUI), permitting independent development, testing and maintenance of each (Wikipedia, 2005d).

**Natural Language Processing(NLP):** NLP is a field of computer science and linguistics concerned with the interactions between computers and human languages (Wikipedia, 2005e).

**Picture Archiving and Communication Systems (PACS):** A PACS has the ability to deliver timely and efficient access to images, interpretations and related data (Wikipedia, 2004b). A PACS includes computers, commonly servers, dedicated to the storage, retrieval, distribution and presentation of images (Wikipedia, 2004b). A PACS consists of four major components: the imaging modalities such as CT and MRI, a secured network for the transmission of patient information, workstations for interpreting and reviewing images, and long and short term archives for the storage and retrieval of images and reports (Wikipedia, 2004b).

**Radiology Information System (RIS):** RIS is a system specific to the radiology department where patient information such as generated reports and appointments for the doctor or for the modality is stored and managed. It is usually integrated into the HIS in hospitals and information is shared between them.

**Social mask:** The term of social masks is generally used for concealing some facts: for example, unsatisfied people may tend to present a positive image for some of the approaches to hide their real point of view (Corpo, 2005).

**The Systematized Nomenclature of Medicine (SNOMED):** SNOMED is a systematically organized computer processable collection of medical terminology covering most areas of clinical information such as diseases, findings, procedures, microorganisms, pharmaceuticals (Wikipedia, 2003). It allows a consistent way to index, store, retrieve, and aggregate clinical data across specialties and sites of care; it also helps organizing the content of medical records, reducing the variability in the way data is captured, encoded and used for clinical care of patients and research (Wikipedia, 2003).

**Statistical Package for the Social Sciences (SPSS):** SPSS is a computer application in which many statistical algorithms were embedded and especially developed for statistical analysis.

**Three-tier architecture:** Three-tier architecture is an application design in which the management of the presentation, the application logic, and the data layers are logically separated.



# CHAPTER 2

## RELATED WORKS AND SOME ASPECTS OF MEDICAL REPORTING

In this section, many different medical reporting methodologies and systems which have been used up to now are evaluated. What their strengths and deficiencies are revealed to shed light on how to set up an ideal medical reporting type. Laboratory departments are required to write, edit, sort, and distribute several hundred reports each day. Most of the reports are examined by other physicians. Standardization of medical reporting systems has not been well established. Some of the earliest attempts focused on developing specialized computer terminals at which professionals could produce the report themselves. Over the ensuing years, several different approaches to computerized reporting have evolved either with well-formed domain sets in structured form or with free-text. There is a need for international standardization of terminology, common methods for measurement, and compatible reporting of abnormal conditions in medical reporting (WHO, 2005). Standardization would enable comparison of research findings, better benchmarking across healthcare organizations, and the development of reliable reporting (WHO, 2005). Conclusions drawn from national and international data would therefore provide a broader and more meaningful picture of individual and population health (WHO, 2005). The desire to analyze outcomes and other measures across institutions has led to the development of standardized reporting lexicons such as Breast Imaging Reporting and Data Systems and Fleischner Society's thoracic imaging vocabulary (Wang & Kahn, 2000). These vocabularies form a basis for some structured reporting applications. Without acceptable domain set, free-text reporting is usually preferred. Before looking into the SISDS methodology to evaluate its merits, first, let's look over some of the earliest attempts focused on developing specialized computer terminals to generate medical reports and later, the existing predominant medical reporting approaches.

## 2.1 Some Early Systems in Medical Reporting

Some of the earliest computerized medical reporting attempts focused on developing specialized and to some extent customized computer terminals at which professionals could produce reports themselves with predefined coded forms to reduce errors and increase health care services. Jost lists some early uses of computers in structured medical reporting based on coded input (Jost, 1986). These systems include the Missouri Automated Radiology System (MARS), the Coded Language Information Processing (CLIP) system, the touch-sensitive CGR systems with IBM 3760 terminal, the Siemens SIREP system (SCRIBE system that is an emulated version of SIREP system (Jeans, Danton, & Kilburn, 1980)), and mark sense technology RAPORT introduced by General Electric. Some of the descriptions from the Jost's study about these system are as follows: "The *Missouri Automated Radiology System* (MARS) was one of the very first systems designed to produce radiology reports using a computer. It was developed initially in 1965 as a prototype system requiring punched card input on an IBM 1620 computer. Later, the system was rewritten in the MUMPS language and installed on a Digital PDP-15 time-sharing system. In order to produce a report, a radiologist was asked to enter coded symbols at a standard computer terminal. The code "P4" might stand for the sentence, "There has been essentially no change in findings since the previous examination." If the proper code could not be remembered, simply typing a "P" would cause a list of possibilities to be presented from which the radiologist would choose. A concatenation of these symbols would eventually lead to the production of a complete report. The final report was presented to the radiologist on the CRT screen for his or her approval and signature. If a report required terms that could not be expressed in coded language, free text could be appended to the report by typing it directly into the terminal. Later, in the early 1970s, the *Coded Language Information Processing* (CLIP) system was developed at the Beth Israel Hospital (Figure 2.1). The CLIP reporting system embodies a philosophy of medical classification and that divides the description of disease into anatomic, descriptive, and etiologic components, the computed displays sets of pre-entered statements. The radiologists then select by letter or number the desired statements, which can be modified by appropriate adjectival or adverbial insertions. The core of this system is an array of about 5800 frames on which the pre-entered statements are organized. Each frame can carry 35 items, which are identified by the numbers or letters on the keyboard. The string of statements selected for inclusion in the report is displayed on the terminal for review as it's is composed. The radiologist then works his or her way through a report, selecting from

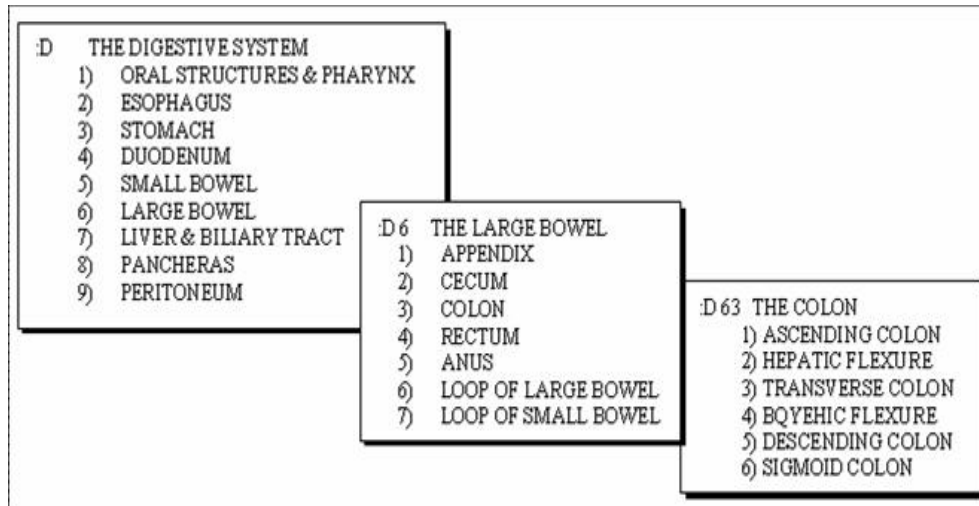

Figure 2.1: Early computer reporting systems often required a radiologist to choose from a list of possibilities. The CLIP system represents a highly developed reporting system based on this principle.

the items presented on the screen. This unique system was undergone steady evolution at Beth Israel Hospital. It seemed to lend itself particularly well to certain types of reports, such as computed tomography (CT) of the head and spine, for which, at Beth Israel Hospital, direct-entry reporting of this type was used for nearly 90 per cent of reports. One of the major advantages of this approach is that reports can be reviewed and “signed” at the time of report generation, thus eliminating the signature cycle, and reports can therefore be printed and distributed immediately. Furthermore, reports are frequently entered in coded form, it is easier to retrieve reports later according to diagnostic codes. Nevertheless, except for a very few medical centers, CRT terminals were seldom used by radiologists. To type at a CRT terminal remains a major obstacle in most departments when the cost is taken into consideration.”

From the early days of computerized reporting there has been an interest in developing a better interface between laboratory professionals and the computer to allow a professional to compose a report more easily and efficiently (Jost, 1986): “one solution has been the development of touch-sensitive terminals on which diagnostic possibilities are projected on a touch-sensitive screen and a radiologist is able to compose a report simply by touching the desired items. The first use of touch-sensitive screens was described by Inger Brodin using a Saab terminal in Sweden in 1967. The firm of CGR was also an early innovator of this type of technology and introduced a French-made terminal at the International Congress of Radiology in 1973. Subsequent versions of this terminal were evaluated in this country.

ANAT INDEX	PATH INDEX	ABDOMEN	ANKLE	BONES	C-SPINE	CHEST AP	CHEST PA	CYS	DIAPHR/MEDIAST	FRACTURE	LUNG/TRACH	MEASURE-MENT	MUSC-SKEL	COLON	ELBOW	FACE	FOOT	GB-LIVER PANCR
Hours	Radio-Density	-LY	-S	GI GEN	GI UPPER	GU	HAND	HIP	JOINTS	KNEE	PELVIS	RIBS	SHOULDER	SINUS	SKULL	SPINE	TECH	Main-Fr
Acute	Healed	Complete	Min	ACCESSORY OSSICLE	EROSION(S)	LINE(S)	SURGERY	ANKLE	-Joint	SOFT TISSUE	Since	Since Last Exam						
Chronic	Healing	Partial	Mod	AND-ALY	FOREIGN MATTER	-Growth	SWELLING	FOOT	-Soft Tis		Appearing							
Non-Specific	Large	Diffuse	Markd	Arthritis	Fracture	-Epiphyseal	TRAUMA	MEDIAL MALLEO	ANKLE	Distal Tibia	Decreasing							
One	Small	Focal	Curved	ATROPHY	-Soft Tis	-Chp	WIDENING	MEDIAL MALLEO		Interos Lig	Gone							
Few	Subtle	Ill-Defined	Irrag	BONE ISLAND	-Bimalleolar	NARROWING	CORTEX	MEDIAL MALLEO		Distal Fibula	Increasing							
Many	Thickened	Scattered	Linear	CALCIFICATION	-Trimalleolar	Osteoporosis	EPIPHYSIS	MEDIAL MALLEO		Talus	Unchanged							
Very	Top Normal	Well-Defined	Lobulated	CYST(S)	-Degen	FUSION	PERIOSTEAL REACTN	MEDIAL MALLEO		Sustentac								
CTR:	cm	mm	%	DEFECT	INFLAM DIS	INFLAM DIS	SCLEROSIS	MEDULLA		DORSALIS PEDIS	Advise Exam							
	0		-	-Fibrous Cortical	INVOLVING	INVOLVING	SPRAIN	MEDULLA		TIBIA	Advise Follow-Up							
1	2	3	/	Deformity	Irregular	Irregular	SPUR	MEDULLA		TALUS	Advise CT Scan							
4	5	6	.	DISLOCATION	LESION BLAST	LYTIC	-Calcaneal	MEDULLA		TALUS	If Clinically Indicated							
7	8	9	X	EFFUSION	EXPANSILE	EXPANSILE	SUBLUXATION	MEDULLA		TALUS	Incomplete Exam							
Normal	Normal Except	Normal Post-Op	Normal Variant	Cannot RIO	POSS	Prob	.	And	And/Or	Or	R	On Rt Side	To	Ant	Distal	Inf	Sug	Clin Correl
Artifact	No Comparison Films	No Def Abnorm	Change Compat With	-LY	-LY	Above	Below	Between	By	L	On Lt Side	Portion	Lat	Lower	Medial	Addendum		
No Evidence	No Inform	No Other Abnorm	Compatible with	Non-Specific	Clinical Dx:	Due to	For	From	In	Both	Bilat	>	Mid	Post	Prox	Addendum		
No Other Change	No Signif Abnorm	Opinion: ?	Proven Case	Unknown Signif	Near	On	Outside	With	Without			Sup	Upper	Amended Report				

RIGHT ANKLE

NORMAL EXCEPT FOR SMALL CALCANEAL SPUR.

NO EVIDENCE OF FRACTURE.

End Entry

Cancel Entry

End Exam

Cancel Report

List

List Only

Diff DR

Scribe 2.0

SMITH, JANE  
032YWF 1-234-56-78 1oft

Undo Find

Figure 2.2: The screen of the SCRIBE system, an emulated version of SIREP system: a stand-alone, touch-screen, computerized radiological reporting system introduced by Siemens. Main display frame for the ankle. Terminology specific to ankle is contained within central heavy black-outlined box. General descriptive terminology is grouped around periphery of display. Report is displayed in lower left corner.

Some of the most influential work in this area emerged at Johns Hopkins University, where the touch-sensitive IBM 3760 terminal was introduced in the radiology department in 1972. This system was nurtured in the early 1970s and became a predominant influence in the development of the Siemens SIREP system, a microcomputer-based, stand-alone, touch-screen, computer-based reporting system.” An emulated version of SIREP system is SCRIBE system presented in Figure 2.2. The system is operated by a radiologist who signals to a computer by touching a glass surface on to which is projected the image of one of 165 slides, each containing words and phrases relevant to the radiographs to be reported (Jeans et al., 1980). The radiologist constructs a report by choosing appropriate words and phrases from lists of standard terms presented graphically on a touch-activated screen (Jeans et al., 1980). Additional lists of more specific terms and differential diagnoses can be requested by the user for abnormal findings and the report is shown on a television screen and is typed automatically when completed (Jeans et al., 1980). Elimination of transcription costs is one of the most advantages of this system while the high cost of each workstation is one of the most important disadvantages. The Siemens system provided a rapid method for optically projecting a number of diagnostic choices on a touch-sensitive panel. Each examination model had a main frame of information with enough pathology and anatomy to report most cases, and a laboratory professional could easily flip from one frame to another. To assist the user, diagnostic terms were arranged around simple anatomic diagrams, and to create a report, items could be probed in any desired order (Jost, 1986). This type of terminal seems to work best in high-volume areas of the department where there is a high percentage of normal studies (Jost, 1986). In this environment, proponents of this type of system believe that computer reporting using a touch-screen terminal is only slightly slower than traditional transcribing methods, and since reports are available immediately for printing and distribution, the overall report turn-around time can be reduced considerably, one of the major limitations of the SIREP system was the high cost of each station (Jost, 1986). The system did not find a wide enough market, and it was discontinued. Another system was RAPORT, an example of which is depicted in Figure 2.2. Mark sense technology has provided a unique method for entering radiology reports into a computer. A radiologist indicates a diagnosis by marking in pencil on specially prepared machine-readable forms. The computer then translates these marks into standard text. This approach to radiology reporting was introduced by General Electric with the RAPORT system in 1970 (Jost, 1986): each diagnostic form contains terms and anatomic diagrams pertinent to a specific topic, such as the hand and wrist or the foot and ankle. In many cases, the laboratory

professional can compose the entire report on the machine-readable form; however, dictation can be appended if necessary. An important advantage of this approach is that a laboratory professional need not be located at a computer terminal in order to generate a report. In the event of a computer failure, the laboratory professional can continue to interpret studies and to generate medical reports using the mark sense forms, and only the printing of the reports is delayed. An example of a similar system to load ordered laboratory tests marked on papers into the database is employed in Hacettepe University and it is still being used very efficiently in terms of ordering laboratory tests rather than generating medical reports. Designing new report forms for new needed report fields on paper and updating these designs is difficult and labor intensive as well as these kind of designs doesn't satisfy most of the medical professionals as they don't prefer to be restricted strictly while generating medical reports. Furthermore, these kinds of systems are complex both visually and cognitively, as in the case of locating the pencil (cognitive focus) at the right dedicated section on the paper.

There are definitely too many similar systems in addition to the systems mentioned in this section in that some most common general approaches in terms of the available technologies are aimed to be described. To explain all these systems is not the subject of this study. To conclude, during the early years of the introduction of personal computers into the medical arena, data collection on coded input was the major policy in terms of clinicians having more available time in the past than now, and moreover they weren't in an environment in a complex of modern practice when compared to that now.

With time, the features that allowed professionals to produce reports based on coded input were used less and less (Waegemann et al., 2002). According to Siström, despite the fact that the concept of using a sophisticated *menu-driven interface* with predefined report shells that provide consistent structure to the report is quite attractive, the very sophistication of the concept causes the interface to be rather complex both cognitively and visually (Siström, 2005). Overly structured data can lead to loss of cognitive focus by professionals, both during input and review (Patel & Kaufman, 1998). Most clinicians note that they have less available time than in the past, because of increased patient volumes, greater demands for documentation, and the increasing complexity of modern practice (Iezzoni, 1999). Now, as medical data sets become increasingly large and complex, much of a professional's time and cognitive effort must be devoted to manipulating the display and post processing controls of workstations for medical reporting in the contemporary structured understanding. This can cause clinicians to experience a loss of overview about the case they are working on when they have to deal with data from different fields, sometimes on different screens (Patel &

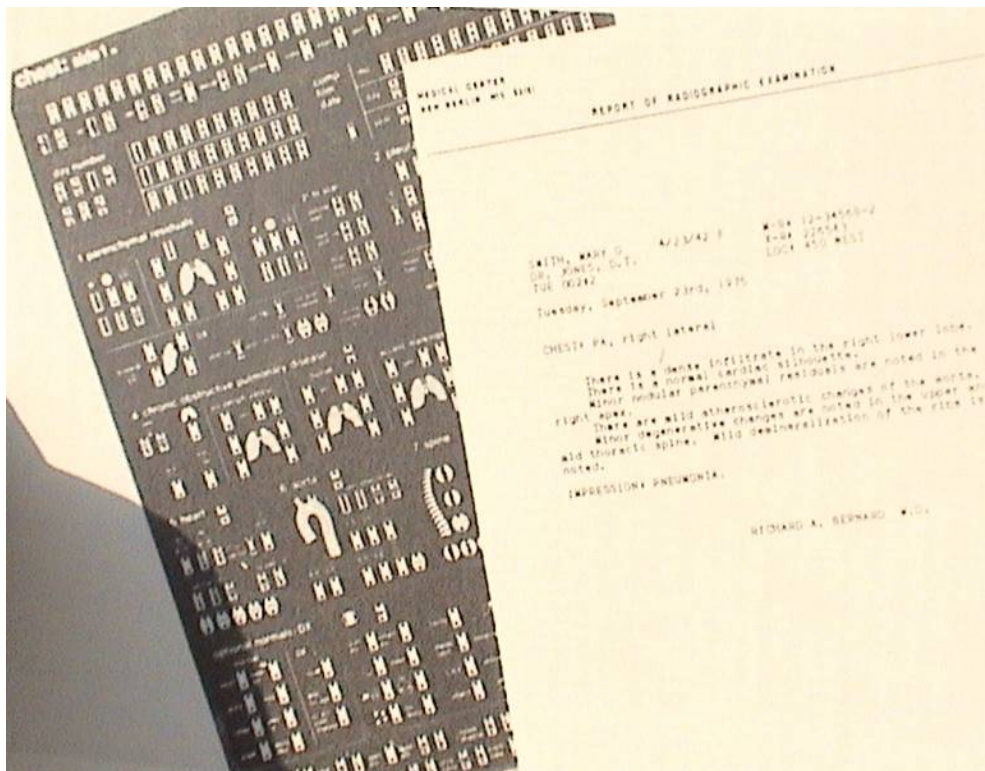

Figure 2.3: The Mark Sense Form RAPORT System: a professional indicates a diagnosis by marking in pencil on specially prepared machine-readable forms as seen at the left. The computer then translates these marks into standard text as seen at the right.

Kushniruk, 1998; Berg, 1996). Furthermore, the coding systems in terms of the medical terms used in the applications didn't gained widespread acceptance by other users or institutions. And, these applications are mainly dependent on computer expert or commercial computer firms for any update, another cause of cost in addition to the high cost of workstations. In this manner, they are restricting healthcare professionals to be more flexible and they are directing them to generate medical reports in free text form as mentioned in the next section.

## 2.2 Most Common Approaches in Medical Reporting

In this section, various existing medical reporting methodologies are evaluated. Their strengths and deficiencies are revealed to bring up some best practices on how to set up an ideal medical reporting scheme. Some of the earliest approaches focused on developing specialized computer terminals at which professionals could produce the report themselves. Some early attempts in medical reporting are mentioned in previous Section 2.1. Over the ensuing years, several different approaches to computerized reporting have evolved mostly depending on free-text. Detail analysis of systems in every approach is the subject of another study. Here, most general approaches are mentioned in summary with their advantages and disadvantages by just explaining several examples of systems in the approaches.

In addition to Some Early Systems in Medical Reporting mentioned in previous section, the existing predominant medical reporting approaches can be grouped under six categories: *handwriting (HW)*, *telephone access (TA)*, *transcriptionist-oriented systems (TOS)*, *real time transcriptionist-oriented systems (RTTOS)*, *dictation by speech recognition (DBSR)* and *all structured data collected in a screen (ASDCS)*.

Some more detailed information about these most common approaches is described as follows:

**Handwriting** Handwriting is usually in free text, but several templates are increasingly used (Waagemann et al., 2002) and they are signed by authors when recorded. Handwriting is often illegible, and varying terminologies and abbreviations represent different meanings to different professionals and lack of a universal common structure of patient information makes it difficult to find relevant information in a record created with a free text. Manual methods are difficult to draw a conclusion both for patients and also for physicians since reports are illegible and not detailed enough as details are assumed to be common knowledge and neglected. Research and building DSS for further use is not possible without machine readable format. Moreover, applying a



DSS is out of question since reports are generated in ink on paper.

**Telephone Access** An interesting supplement to a computerized reporting system is the automated voice recording system known as RTAS (Jost, 1986): In its original form, described by Kolodny in 1974, the system was composed of several reel-to-reel audiotapes, each one of which was accessed by dialing an individual code number from a touch-tone telephone. Thus, the laboratory personal would dictate a report, the dictation would be recorded in analog form, and a specific dictation could then be accessed by any physician using a standard telephone. Since its original development, the system has been redesigned so that the voice information is now stored digitally, and in this form, the system has been installed successfully in a number of departments and voice records can be accessed by computers as well. Although, it can provide rapid access to reports, it suffers the same drawbacks of handwriting in terms of building DSSs and making research, since current technologies are still limited to turn speech into machine-readable form in a high accuracy rate.

**Transcriptionist-Oriented Systems** The process of dictation was born as doctors dictated to secretaries or other assistants, and ultimately to medical transcriptionists, who captured the spoken text with shorthand to be transcribed later; in the second half of the 20th century, dictation devices were introduced, thus replacing the human interface in the dictation process (Waegemann et al., 2002). By far the most widespread technique for entering radiology reports into a computer involves the use of transcriptionists. These systems allow the professionals to dictate a report in the usual way, using standard dictation equipment. Sometime later, a transcriptionist transcribes the report but uses a computer terminal instead of a standard typewriter to prepare the report. The editing of reports is, of course, a simpler task, because with word-processing techniques, it is possible to correct a mistake without retyping the entire report. This method is being used in the hospitals at which we studied. While recording voice to be transferred into the free-text machine readable form by transcriptionist later, an expert's eyes never leave images or patients and his/her hands are free to manipulate image display controls or examine patients. Although TOS is generally well received and well accepted in most laboratory departments and look-away problem in this way is removed, it carries many drawbacks. it can often take a long time for patients/physicians to access generated medical reports. Once the report is completed and a diagnosis is specified, the report still has to be dictated and then

typed up by transcriptionists. Another drawback is that all recording process often has to be repeated by professionals if any update is needed in recorded speech for the sake of completeness. Furthermore, reports still must be submitted to the laboratory professionals for approval and signature even if it is dictated into text by transcriptionist, that is, some more time has to be reserved by professionals to examine the correctness of transcribed reports before approval phase. Once a report is approved, it is then necessary to go back to the computer and indicate that the report is finalized. Thus, the signature cycle remains a problem that must be addressed. Moreover, because a professional's review of the report documents, prior to signature, happens hours to days (Jost, 1986) after the dictation, specific details of each case might not be fully remembered. This could result in errors. The remedy for this problem requires rework to review images or findings, a process that can be cumbersome and time-consuming even in a soft copy reading environment. Furthermore, patients are becoming increasingly anxious about the privacy of their medical records, one concern where transcriptionists rather than professionals transcribe medical reports in speech into machine readable form; in that, the privacy in ethic rules between doctors and patients in terms of keeping patient information in secret without the permission of patients is not abided by. Policy makers still doubt that Electronic Health Record (EHR) environments can protect patient privacy, despite a decade of effort (Lehmann et al., 2006). On the other hand, economically, some healthcare providers show substantial savings as transcription is diminished or eliminated while some of the return on investment (ROI) could be quite impressive (Sinha, 2000)<sup>1</sup>. In all sectors, technological diseases, a cause for concern where transcriptionists dictate huge number of medical reports using keyboard in reporting phase, cost approximately 100 billion dollar for USA economy (Mogensen, 1999). Decision supporting ability in real time seems impossible since professionals don't use computers during recording reports as speech in free-text form.

**Real Time Transcriptionist-Oriented System** RTTOS has been preferred to address the signature cycle to provide immediate access to reports once completed by saving overall time although it carries most of the other drawbacks that TOS has. Real time reports are not returned to the professionals for formal signature but are distributed immediately, thus eliminating the signature cycle and reexamining images or patients.

---

<sup>1</sup>400,000 medical transcriptionist are needed in the USA alone and this represents \$18 billion to \$24 billion cost in a year (Sinha, 2000)

However, a medical transcriptionist is required in real time during reporting process, a state which is very costly (Mogensen, 1999) and necessitates a thorough communication between laboratory professionals and transcriptionists. Generally all dictated report has to be reexamined by professionals before signature and dissemination for the sake of truthfulness, which means doubling the efforts.

**Dictation by Speech Recognition** The development of a conversational computer has been an elusive goal for many years (Grasso, 2003). SR is a very complicated process although it seems simple for human being. Many misunderstandings occur when a listener cannot see the person who is speaking. Negative and positive feedback is continuously used in human-human communication as a way of showing attention, recognizing the intention of what the other person is saying or to signal non-understanding and misunderstanding by using many other ways to express ourselves such as facial expressions, gesture, bodily posture, speech reading and other objects in our environment to clarify things, as texts, maps, images, physical models etc (Sistrom & Langlotz, 2005a).

The secrecy to the ability of the human being for SR is: excellent perception of both the visual and the auditory; a great amount of knowledge gained mostly by the help of education and experience; people living next to the airport and railway stations very soon filter out the noisy air traffic and train the ability of comprehension and construction relations. Moreover, the following kinds of skills and abilities are not applicable to computers: (1) the microphone used for the perception has a very simple structure when compared to the human ear. Human ears can select and listen to just one of the sources of different voices produced at the same time. For example, human ears can choose to listen to one person from four different persons speaking at the same time in a room. This is caused filtering out “white noise”. Unfortunately there is no electronic technology to accomplish this process. Close mouth microphones (headphones with microphone) are the most successful microphones to perceive the voice in today’s technology. Higher signal/noise ratio (SNR) is the success of this technology. In this technology, the signal is the sound produced by mouth and the noise is the sound emitted around. The intensity of a sound produced by the mouth is much greater than the sound coming around when the microphone is positioned near to the mouth. But, this method is unfortunately badly affected easily when a noise coming from around is greater in intensity than the due signal. Furthermore,

the human being has another ability called completion in the perception. The brain completes easily any word even though the greater section of it is not actually heard by the ear, (2) the criteria about the knowledge and the understanding of a speech language are very important in SR. It is very difficult to write some speech that is in an unknown language, i.e. not the native language. It can be also difficult to write some speech that is in any other language which is known, but different from the native language. Recognizing of any speech without understanding it, is very difficult even for human beings. The computer is to face to face these difficulties and try to convert speech into literary without understanding, (3) Reading lips is done automatically by the human being and this increases the success of SR fairly well. The computer unfortunately has no such abilities.

New technologies, such as speech recognition and structured reporting systems, have been developed to address many shortcomings (Sistrom & Langlotz, 2005a) mentioned in previous data collecting methods. A study suggested that health care providers might use medical applications more often if speech, rather than conventional input techniques, were the interface modality (Shiffman, W.M Detmer, & Fagan, 1995). Although several studies have analyzed the speech-driven approach to facilitate the collection of data in medical area as radiology, pathology, dental examination (Feldman & Stevens, 1990), anesthesia (Smith, Brian, Pettus, Jones, & Sarnat, 1990), Pediatric Gastroenterology (Smith, Brian, Pettus, Jones, & Sarnat, 2001), Orthopedic Surgery (Svanfeldt, n.d.), we haven't encountered a study which both uses a speech-driven approach and analyzes the method of data collection in a bilateral interactive, dynamic and structured (controlled vocabulary) understanding in the literature. Isolated speech recognition (ISR) and continuous speech recognition (CSR) are the two approaches in dictation by speech recognition. Continuous-speech systems recognize words spoken in a natural rhythm, while isolated-word systems require a deliberate pause between each word. Although more desirable, continuous-speech is harder to process, because of the difficulty in detecting word boundaries. ISR is the simplest speech recognition approach. ISR works best for very limited vocabulary which is not suitable to medical fields having very complex vocabulary. Large vocabularies cause difficulties in maintaining recognition accuracy, but small vocabularies can impose unwanted restrictions on the naturalness of communication (Grasso, 2003). Current medical applications in which a speech interface modality has been integrated generally

uses CSR free-text data collecting methods unilaterally, user-to-computer, speech-to-text simultaneously. While dictating reports into the free text machine readable form in real-time using the speech interface, users are necessary to return computer to confirm what is dictated and to correct mistakes with facing a real look-away problem. Slow report turnaround, suboptimal report quality and accuracy, and the unsuitability of report information for quality improvement and research are some of the limitations of these applications. Ricky, Taira, and G Soderland (2001) states by addressing many shortcomings that NLP (natural language processing) functionality in medical area has still been recognized as a promising research area to turn free text into structured data mainly to be used for designing DSSs. While improvements have taken place, speech technology has several limitations that keep it out of the mainstream such as speaker dependence, continuity, and vocabulary size. It is usually believed that speech recognition technology can be used when there is a compelling reason such as hands-busy, eyes-busy, and mobility required applications. The current generation of continuous speech recognition systems claims to offer high accuracy (greater than 95%) SR at natural speech rates (150 words per minute) (Zafar, Overhage, Clement, & McDonald, 1999). But, providing an accuracy rate greater than 95% is not an easy issue to handle in a natural rhythm and in the noisy environment of hospitals: the accuracy rate is strictly dependent on many factors as teaching grammar, well-trained speech files for specific users and vocabulary size. Speech recognition holds promise for medical reporting. Despite considerable advances in computer technology, no machine can possess as sophisticated an ability as the human being. Therefore the success of SR for the machine compared to the human being is limited and the keyboard and mouse are still the principal means of entering data.

Our next study is going to include a speech interface modality (SIM) which is integrated into the SISDS methodology. A bilateral interaction is aimed to perform with the SIM to remove look-away problem during examination as health professionals will be guided by computers through medical reporting (text-to-speech) and will be able to generate their reports by entering data with their voices (speech-to-text) via a headphone attached to a microphone without the need to look at monitor and return computer to record results. Moreover, users are aimed to activate a computer to examine and record specific data entries in a report. Bidirectional intelligent interactivity is going to be provided with speech to enable hands-free and eyes-free collection of data

Figure 2.4: An example for ASDCS Method: 156 different fields to be entered for every patient to compose a colon report in its use of multiple combo boxes, text boxes, a cause for cognitive overload.

in real-time by the help of the advantages that the SISDS methodology presents.

**All Structured Data Collected in a Screen** Unlike conventional “free-text” reports, structured reports incorporate a standardized set of concepts in a predefined format (Wang & Kahn, 2000). A practical goal of structured reporting applications is to capture most of the information in structured format and allow free-text comments as needed; the major advantages of this approach include reduced transcription cost and turn-around times, increase report completeness, greater usefulness of cases for teaching and research, and improved quality assurance, better review (Wang & Kahn, 2000). Efforts to apply structured reporting to laboratory data from the 1960s (Wang & Kahn, 2000; Jost, 1986). In these systems, the documentation process is guided through the use of titles and templates (Waegemann et al., 2002) <sup>2</sup>. The purpose is to produce data of more consistent quality, make information more usable for decision support, make information more complete and more easily retrievable and templates may also present data for the physician to choose from menus, lists, or forms (Waegemann et al., 2002). A haphazard premeditated example for this approach to compose a colon report is

<sup>2</sup>Templates are guides used to create standardized health information documentation

presented in Figure 2.4. The appearance seems very complicated and irritating; it is difficult to determine necessary and optional fields; it is very difficult to constitute algorithms which provide instantaneous decisions to assert necessary and optional data entries if a new condition occurs in terms of the entered fields. For instance, a data entry for the question of “how is the position of rectum segment” might have a value of “normal” or a value of “there is anomaly”. If it takes the value of “normal”, there is no need to fill the data entry for “how is the settlement of rectum segment”, which may have the values of medial, lateral, superior or inferior. One other example is the question of “is there a narrowness in the rectum segment”, which may have a value of “there is” or a value of “there isn’t”. If it takes the value of “there isn’t”, there is no need to fill the data entry for “what is the length of the narrowness”, “what is the diameter of the most narrow section” and “how is the mucosal shape of the narrowness”, which may have a value of “regular” or a value of “irregular”. Controls are very difficult to handle even if you constitute a structured design to collect data in a high quality standard. You still need new computer programs to be built to define all these controls for every medical report formats and you need a computer engineer near you to build these programs. Professionals face several messages like “you can not save without filling the field of ...)” when they try to save reports even if all these controls are established. And these kinds of warnings irritate professionals not to use a structured reporting design and they may prefer to use free-text forms instead of structured forms which cause a cognitive overload. The capturing of information in a standard structured format can be used for population-based health policy decisions, and it is becoming important for medical departments to provide information that can be aggregated locally, regionally, and nationally for outcome analysis. Another example to these systems is the UltraSTAR (Ultrasound Structured Attribute Reporting) system at the Brigham and Women’s Hospital (D. Bell & Greenes, 1994) and chest radiography reporting system at John Hopkins Medical Institution (Wang & Kahn, 2000). In this system, data are stored after all processes are completed in notes whether they are in free text or formatted form. Ultra-STAR mainly aims to store standardized pelvic ultrasound patient data for retrospective study rather than serving a DSS (D. Bell & Greenes, 1994). An example of it’s screenshot is depicted in Figure 2.5. Many windows remain open simultaneously having radio buttons, combo boxes, buttons and checkboxes to select concepts and in its use of multiple small windows, a cause for cognitive overload. Cognitive overload and dependence to extensive computer knowledge for updates for

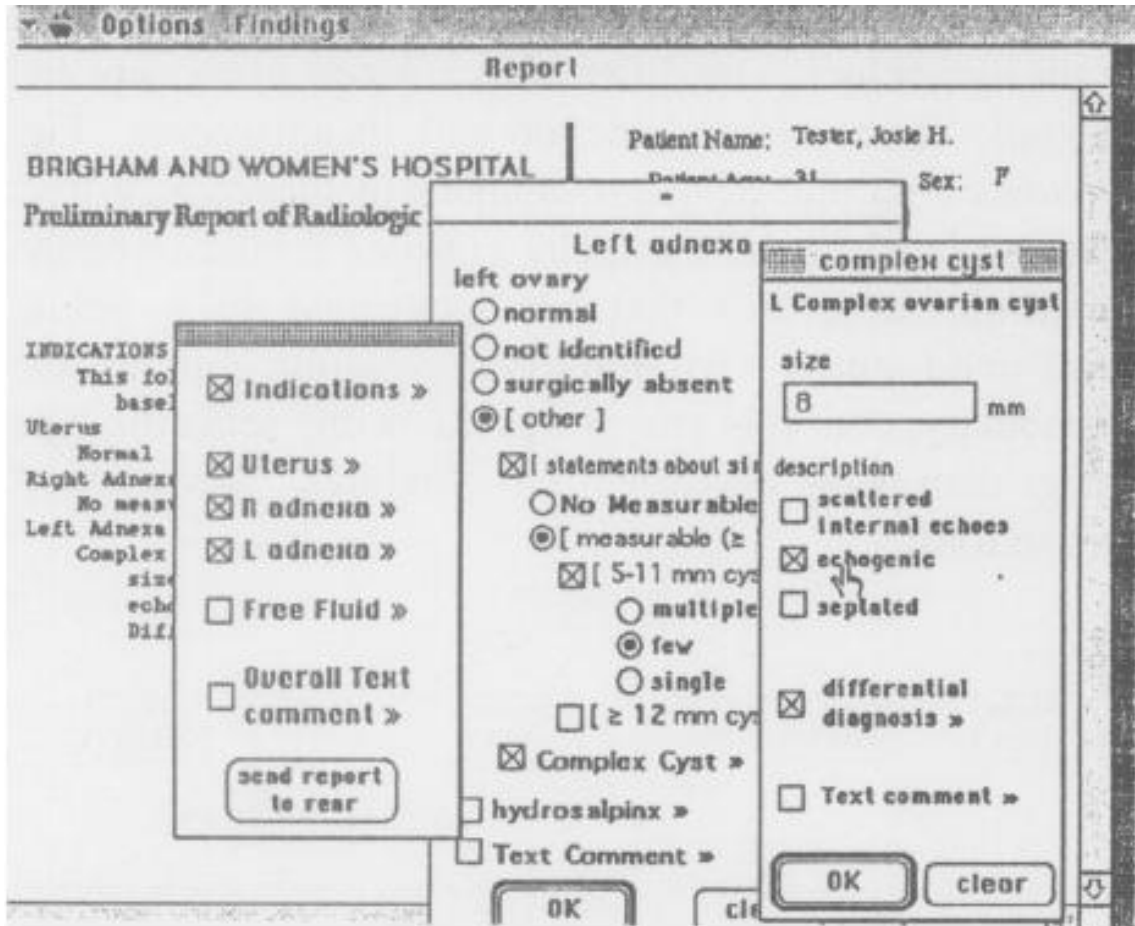

Figure 2.5: An example for ASDCS Method, UltraStar: Many windows remain open simultaneously having radio buttons, combo boxes, buttons and checkboxes to select concepts and in its use of multiple small windows, a cause for cognitive overload.

the architecture of report formats have been the most effecting factor for these kinds of systems to be used less and less, thought, they have many advantages. We would like to emphasize that one major obstacle to the success of computer systems is that physicians have difficulty in entering data (D. S. Bell et al., 1992). Furthermore, these kinds of systems are complex both visually and cognitively, as in the case of locating the cursor (cognitive focus) at the right dedicated section (combo boxes, text boxes, check boxes, radio buttons, etc.) on the screen.

## 2.3 Summary of the Analysis of the Related Works

These approaches except ASDCS mostly depend on free-text format. Free text is the unguided, free-flowing recording of a professionals' thoughts and observations. In *handwrit-*



ing, the reports are generated manually, conventionally ink on paper. *Telephone access* includes voice records recorded by report generators themselves in digital or in tape format and data can be accessed with specific patient numbers using telephones or computers. *Transcriptionist-oriented systems* allow the report generators to dictate reports in speech recording devices. Recordings are later transcribed by transcriptionists using word processing tools at computer terminals. In *real time transcriptionist-oriented systems*, reports are transcribed by transcriptionists in real-time by an interaction with report generators. On the other hand, in *speech recognition approach*, professionals' speeches are transcribed into machine readable free-text form in real-time by an application that is integrated to a speech interface by which transcriptionists are aimed to be eliminated.

Despite the fact that those systems that allow transcriptionists to enter reports in free text are currently the most prevalent<sup>3</sup>, overall process is not cost effective (Sinha, 2000). The time between dictation and report availability is long on average (Sistrom, 2005). In addition, automatic methods fail to turn free text into structured format at a satisfactory level, on account of several factors such as equivocal abbreviations, large vocabulary, ungrammatical writing styles, many different codes and complex medical terms. What's more, details in reports are neglected since they are assumed to be common knowledge (Taira et al., 2001).

In order to remove the deficiencies of free-text recording, *structured data entry* has been proposed as an alternative approach by different groups, but has not yet gained widespread acceptance primarily on account of additional, and sometimes excessive, *cognitive overload* (Kahn, Wang, & Bell, 1996; Kahn, 1997). The *all structured data collected in a screen* (ASDCS) approach aims to collect structured data by incorporating a standardized set of concepts in a predefined format on a screen supported by visual elements, such as sub-screens, buttons, combo-boxes etc. Structured data collected in the ASDCS approach are mainly designed to be used for further research rather than a good care for patients in real time.

DDSSs are difficult to built without tedious pre-processing, data preparation and new data insertion steps since data are collected in free-text in these methods except ASDCS. Medical reports are usually in free-text format and "natural language processing (NLP)" methods are not successful to turn free text into structured format because of equivocal abbreviations, large vocabulary, ungrammatical writing styles, many different codes and complex medical terms. On the other hand, doctors acknowledged that there is no need for completeness, as colleagues would be able to fill in the gaps via an inferential process in

---

<sup>3</sup>Surprisingly, second to handwriting (Waegemann et al., 2002).

medical reports. Medical records are recognized as imperfect, even for their primary purpose of assisting in patient care (Patel & Kaufman, 1998). Unfortunately, reliable data is available in very few areas of medicine (Delaney, Fitzmaurice, Riaz, & Hobbs, 1999). Consequently, medical reports, which constitute the main source of medical data, are almost always in unstructured format and incomplete since details are assumed to be common knowledge and left out (Taira et al., 2001).

All these medical reporting approaches mentioned above have some strengths as well as deficiencies when compared to each other whereas they all have many deficiencies for being an ideal platform which satisfies everyone whose priorities are different from each other. We briefly mention the related approaches in medical reporting to reveal how to set up an ideal medical reporting scheme by revealing their advantages and disadvantages/deficiencies described in the following paragraphs, a summary of which is presented in Table 2.1 by rating them on a four-level evaluation scale based on the general views as highlighted by the results of several studies (Waegemann et al., 2002; Siström & Langlotz, 2005a; Sinha, 2000; Jost, 1986; Patel & Kaufman, 1998; Feldman & Stevens, 1990; Delaney et al., 1999; Mogensen, 1999; Grasso, 2003; Shiffman et al., 1995; Smith et al., 1990, 2001; Svanfeldt, n.d.; Ricky et al., 2001; Zafar et al., 1999; Wang & Kahn, 2000; Siström & Langlotz, 2005b). The criteria decompose as “*cost effective (money)*”, “*quality of care*”, “*patient safety*”, “*report completeness*”, “*retrospective study/research*”, “*teaching*”, “*establishment of DDSS*”, “*public health*”, “*reducing cognitive load*”, “*quick preparation*”, “*rapid dissemination/access*”, “*reducing look-away problem*”, “*not needing extensive computer knowledge*” and “*privacy*” to cover the different needs of all the actors in the field such as laboratory professionals, examining physicians, institutions, patients, government, health insurance companies. These criteria are most commonly mentioned in the references in different terms by emphasizing the several aspects of the six common data collecting methods in medical reporting as “Handwriting”, “Telephone Access” (TA), “Transcriptionist Oriented System” (TOS – recorded speech files to be dictated later by medical transcriptionists), “Real Time Transcriptionist Oriented Systems” (RTTOS – recording in real-time using medical transcriptionists), “Dictation by Speech Recognition” (DSR) and “All Structured Data Collected in a Screen” (ASDCS). For instance, as seen in Table 2.1, medical errors (the criterion of patient safety) are very likely to occur while generating medical reports as a disadvantage (- -) whereas there is no need any computer expertise (the criterion of not needing extensive computer knowledge) as an advantage (+ +) in the approach of TOS. Besides, in the same approach, TOS, report completeness has been moderate (0) since contents of medical reports depend on the laboratory

professionals who generate these reports, sometimes reports seem complete and other times details are assumed to be common information and left out of medical reports. Furthermore, the criterion of reducing look-away problem seems as a slightly advantageous (+) in the same approach, TOS, as laboratory professionals doesn't need to leave their eyes out of images or patients while generating medical reports by recording their speeches in recording devices, which are afterwards transcribed into machine readable form by transcriptionists. However it still bears some shortcomings as laboratory professionals have to check machine readable forms before signature/approval phase. On the other hand, the criterion of reducing look-away problem is completely well ensured (+ +) in the approach of TA where speeches are recorded to be reached by physicians by specific patient numbers, there is no need of signature/approval step before dissemination as in the case of TOS approach.

On one side, when thinking about the design of reporting systems, all reporting system above have proven that, the success of a reporting system lies on firstly efficient recording as being the primary goal rather than the secondary goals such as statistical analysis and research. On the other side, it is a reality that most current methods of medical reporting are insufficient in generating structured reports and helping experts make statistical analysis for further conclusions to make use of huge amounts of information. Current methods of medical reporting are also insufficient in providing simple standardized interface while handling structured data and customizing patterns to the users' needs. The reporting cycle might be closed instantly and qualified data might be collected as experts themselves record on effective systems when such systems provide the benefits of structured and bilateral interactive recording and become easier and faster than conventional data collecting techniques. In this study, we aim to establish a novel method that encompasses most of the favorable features of several existing medical reporting methods as indicated high (+) and relatively high (++) in Table 2.1 such as "not needing extensive computer knowledge" for the approaches of HW, TOS and RTTOS in an implementation wholly while removing most of their deficiencies as pointed out relatively low (—), low (-) in Table 2.1 such as "establishment of DDSS" for HW, TOS, RTTOS, TA and DBSR, and "reducing cognitive overload" for TA, DBSR and ASDCS . Moreover, it aims to introduce and promise new advantages such as an easy way of both defining complex interactive structure architecture of specific report formats and building a DDSS in terms of the most recent knowledge by privileged users without any extensive

---

<sup>4</sup>The *look-away problem* is caused by tasks other than examining patients or images that need to be done frequently, eg. in case of dictation, users that have to check what is dictated and correct mistakes while generating reports are faced with a look-away problem.

Table 2.1: General evaluation of the existing medical reporting approaches in terms of advantages and disadvantages: Handwriting (HW), Telephone Access (TA), Transcriptionist-Oriented Systems (TOS), Real Time Transcriptionist Oriented System (RTTOS), Dictation by Speech Recognition (DBSR) and All Structured Data Collected in a Screen (ASDCS). The four-level evaluation scale is defined as follows: relatively low (--), low (-), moderate (0), high (+) and relatively high (++).

Criteria	HW	TOS	RTTOS	TA	DBSR	ASDCS
Cost effective (money)	++	-	--	0	0	0
Quality of care	--	0	0	-	0	0
Patient safety	-	--	0	+	0	+
Report completeness	--	0	0	0	0	+
Retrospective study/research	--	-	-	-	-	++
Teaching	--	-	-	-	-	+
Establishment of DDSS	--	--	--	--	--	0
Public health	--	--	--	--	0	+
Reducing cognitive load	++	0	0	-	-	--
Quick preparation	0	0	+	++	0	--
Rapid dissemination/access	--	--	0	+	+	+
Reducing look-away problem <sup>4</sup>	--	+	+	++	--	--
Not needing extensive computer knowledge	++	++	++	-	-	--
Privacy	--	-	-	-	++	++

computer knowledge. Furthermore, medical reports could be generated in several predefined languages and could be transformed from one language to another instantaneously as is in terms of the same domain set; thus report sharing is simplified. These extra advantages haven't been covered yet by any medical approaches explained in previous two sections.

# CHAPTER 3

## CONCEPTUAL UNDERSTANDING OF THE SISDS METHODOLOGY

A common problem confronting architects of *electronic healthcare record* (EHR) systems is how to present the detail that is required by some users while at the same time permitting the experienced users to easily find the information they need (Waegemann et al., 2002). According to some studies in cognitive psychology and sociology, *free-text communication* is the most effective way for coordinating a complex medical task (Sistrom, 2005; Garrod, 1998; Cimino & Patel, 2001). Consequently, it is not surprising that medical reports, whether on computer or in paper, are usually in free-text and almost non-structured format such as, simple templates with contents completely dependent on the professionals who generate them. This situation poses difficulties as converting the reports into structured electronic form and then extracting semantics is still a challenging task. Some practitioners regard free text as a symbol for medicine as an art in contrast to structured text and interactive recording, to which some other practitioners may regard as scientific healthcare processes (Waegemann et al., 2002). Users who wish to place a priority on minimizing the time required for the capture of data usually prefer non-structural methods (Waegemann et al., 2002), a cause for making the TOS approach most widespread. On the contrary, users who place a priority on improving the efficiency of reviewing or analyzing the information have tended towards structured information capture methods (Waegemann et al., 2002) by which collected data can be easily used both for further research and for constructing DDSSs. On the other hand, users who place a priority on improving the quality and efficiency of patient care by using more effective workflow processes have increasingly moved towards interactive methods (Waegemann et al., 2002)<sup>1</sup>. The transcription section or auxiliary procedures to write

---

<sup>1</sup>Interactive recording is a more complex version of structured recording as it interactively prompts for information and provides feedback to the person using it (Waegemann et al., 2002), i.e, guides the user

reports is consequently removed with interactive recording. The methodology that we propose is aimed to serve promptly to all of the users in these three categories with different priorities. Waegemann et al. (2002) makes a comparison which is about complexity, value, and characteristics of information capture styles in Appendix D. The comparison asserts that structured and interactive methods are superior to unstructured methods in many perspectives, although they are more complex to be built and unstructured free-text methods are currently predominantly widespread. In our methodology, a structured design supports an interactive design and vice versa. They both use each others superiorities when used together during report generation as well as a user-friendly interface is performed especially firstly for the laboratory professionals to generate robust medical reports effectively and secondly for physicians to interpret these reports better to practice a desirable medicine.

First of all, a medical reporting approach has to provide an ease of use for the author of medical reporting with a user-friendly interface. In addition to that, it also has to take into consideration of the differing needs of other users who benefit from it. These other users differ in some aspects as knowledge, responsibility in the health care service process, need for content, ability to locate the needed content, time available to read and analyze, and motivation to understand health information. Professionals frequently declare the need for improvements in medical report quality at their institutions (O’Leary, 1999; Clinger, Hunter, & Hillman, 1998; Naik, Hanbidge, & Wilson, 2001; Siström & Langlotz, 2005a), mainly due to the intensive deficiencies of the most common approaches presented in Table 2.1. These declarations indicate a necessity for new methods that are both effective and have less cognitive pressure – in between free-text reporting and sophisticated menu-driven structured approaches, which would provide a through communication among professionals, and also facilitate high level operations, such as population based inferences and diagnosis/decision support. In this section, we will first discuss some essential characteristics of such a method, and then formally describe a particular solution that provides them. A Web-based realization and implementation of the proposed solution is presented in the next Chapter 4.

### **3.1 Some Essential Characteristics of an Effective Reporting Method**

*Cognitive load and hierarchical structure:* As already mentioned in the previous paragraphs, reducing the cognitive overload is of utmost importance in composing medical reports. There

---

through the data entry process.

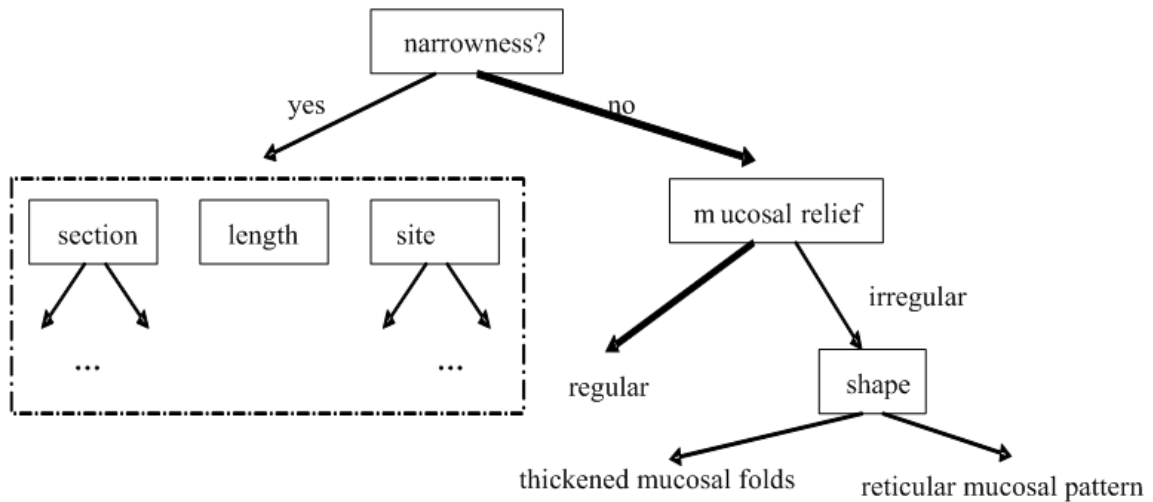

Figure 3.1: An example of the hierarchical structure inherent in the medical reports. The question of interest is the following: “*Is there any narrowness without a clear expansion in the esophagus during the transition of the contrast media?*” (see text for the details). Boxes correspond to data entries and line labels indicate possible answers. The dashed box groups a set of data entries that are activated when there is narrowness. The normal values are shown with thick edges.

exists a direct relationship between the amount and complexity of information that need to be entered/processed by users and the cognitive load. Hence, *reducing the amount and complexity of information would also reduce the cognitive load.*

Let us consider a typical esophagus radiology report <sup>2</sup> which would, among other things, contain observations about the shape of the mucosal relief, the section, length and the site of the narrowness of the esophagus etc. When entering data for a particular case, only a subset of this information may actually be relevant. For instance, one of the questions to be answered in this report would be the following: “*Is there any narrowness without a clear expansion in the esophagus during the transition of the contrast media?*” <sup>3</sup>. Usually, the answer to this question is *no* (“There isn’t” in English, “yok” in Turkish in the report), and in this case the mucosal relief should be entered, which can be either *regular* (“normal” in English, “normal” in Turkish in the report) or *irregular* (“not normal” in English, “normal değil” in Turkish in the report). If the mucosal relief is irregular then the shape of the irregularity should also be specified; otherwise, this information is not required. As long as there

<sup>2</sup>The entire structure of the esophagus report including all data entries and triggers can be found in Appendix A.

<sup>3</sup>All related data entries can be reached in the data group numbered as 6 in Appendix A.



is a narrowness, which is the answer to the question is *yes* (“There is” in English, “var” in Turkish in the report), mucosal relief is not important and a completely different set of information should be entered including and depending on the properties of the narrowness, such as its section, length and site. Note that, this inherently leads to a *nested and hierarchical* structure as depicted in Figure 3.1, in which data entered at a certain point determines the information flow, and consequently, the related data that should be entered. Although the total number of possible realizations may be large in such a setting (due to the combinatorial expansion), by *interactively walking on the necessary steps* while completing the report, the number of data entries that need to be specified can be reduced considerably (ex. it is unnecessary to ask for/display anything related to narrowness unless the user explicitly indicates that it exists) – a process which effectively corresponds to following a path on the hierarchy. This hierarchical structure is indeed not specific to this particular example, and emerges as a common feature of almost all kinds of medical reports (Waegemann et al., 2002). We would like to note that the dependencies between data fields may be more complex, i.e. *the condition of requesting a certain information may also depend on the values of various other data fields that may or may not be dependent on each other*. Furthermore, as several sources point out, in most cases medical reports belong to normal cases in which there are only few fields with abnormal values depending on the case under examination. Ideally, much less time should be spent to record normality, and for the sake of cognitive simplicity the user should not receive data entries related to unnecessary abnormal situations. In the hierarchical structure this can simply be achieved by conducting an initial simulated walk on the necessary steps using the default values for the normal cases (i.e. no narrowness and regular mucosal relief in our example above). To be more specific, an constituted example of this kind of report format is presented in Appendix A. In this report format, initial data entries in the main data groups, which are written towards the main numbers, are triggered automatically as the initial report format ( Figure 5.2). The initial report format may include some other data entries for which conditions specified as normal for the main data entries succeed: for instance, narrowness is triggered as *no* as a normal case in the initial skeleton of the report, and there is a specified condition (*[narrowness] == “no”*) linked to this initial main data entry, thus, the data entry “mucosal relief” is included in the main report with the normal case of “regular” as indicated in Figure 3.1. Later, the report is rearranged in terms of “the conditions” triggered by the requests from the user to take its final form.

*Abstraction:* In medical reporting, we can identify three main goals: (i) to provide an ease of use for the author who generates reports, (ii) to make medical reports easily accessible,

complete and comprehensible by all users, and (iii) to be able to extract medical data out of them for further analysis such as building DDSSs and making research. In order to accomplish these goals, abstraction at several levels seems essential. Here, we will consider three main levels of abstraction: data level, logic level and presentation level.

**Data level** *Data Level keeps the data.* The data fields, or *variables*, which constitute a report must be consistent and *well defined*. A typical medical report contains many nominal and numerical values with different measurement units (such as, temperature, length, weight, volume, date, etc.), and without specific data-types for each such variable it is unavoidable to lose some information when working directly with the data afterwards. What’s more, specific data-types enable unit conversion (eg. converting weight from kg to lbs or vice-versa), which facilitates information sharing. The ability to assign *default values* to data fields and to *define constraints* over them, such as a permissible value range, are other useful features that would reduce the cognitive overload and prevent erroneous input by guiding the user during data entry. A structured and normalized relational database including all these features in terms of the syntax presented in Table 4.1 is constructed and mentioned in the following chapter as presented in Appendix C.

**Logic level** *This level uses and manipulates the data model in data level.* In a medical report, a data entry can *encapsulate* multiple data fields. To exemplify, in our sample esophagus radiology report, the size of the first ulcerated lesion may be defined in an interval by specifying its lower and upper bounds (one data field for each). In addition that, as discussed above there may exist dependencies and relations between data entries that trigger their activation (eg. information about mucosal relief is required only when there isn’t any narrowness); here, the trigger conditions are defined in terms of boolean expressions that refer to the data fields (eg. *narrowness = none*), and thereby require an abstraction above the data level. The activation may also be realized by constraints that are defined for the current data entries as well as the values of other data entries either to include data entries into the report or to alert the user about a case such as a diagnosis by specifying a rule-based conditions. An example of which is a specified trigger for a report wide triggering condition either to trigger a new data entry in any data group, to trigger a data group or to trigger a warning or a diagnosis such as:

**Condition:**  $[3.extravasating] == \text{“none”} \ \&\& \ [4.transition] == \text{“delayed transition”},$

, in which the numbers of 3 and 4 refers to the labels (unique identifiers) of the specific data groups and “*extravasating*” and “*transition*” refer to the name of parameters in the data fields that are in the data groups, and “none” and “delayed transition” are the values of the data fields. The condition comes true if each value of the both data fields exists concurrently, since the sign  $\langle \&\& \rangle$  refers to “AND” in programming languages.

Another example for an other kind of a specified trigger, which is defined for the data group numbered as 5 in Appendix A, for a specific data entry to trigger a new data entry when the specified condition succeeds is:

**Condition:**  $[peristalsis\_wave] == \text{“primer secondary tertiary”} \ || \ [peristalsis\_wave] == \text{“tertiary”}$ ,

in which “*peristalsis\_wave*” refers to the name of parameter in the data field that is in the data group numbered as 5, and “primer secondary tertiary” and “tertiary” are the values of the data field. The condition comes true if one of the values exists, since the sign  $\langle || \rangle$  refers to “OR” in programming languages. Conditions are defined as boolean expression and the boolean expression evaluates to true. Some other detailed information about the triggering conditions are explained in the next section while clarifying features of data group in the proposed methodology.

**Presentation level** Data and logic levels together can be regarded as constituting the back-end that defines the structure of the report. Presentation level, on the other hand, is the front-end that defines *how the report is rendered for data collection and viewing*. The separation of presentation from data and logic would enable to generate different views of the same data based on user requirements (for instance, in tabular form or in a natural free-text like style as described in the next chapter (Figure 4.21)). Moreover, this when combined with data and logic levels brings support for report generation in multiple languages (Figure 4.9) without requiring natural language processing methods, which are liable to medical errors and still not reliable especially for medicine (A. H. Morris, 2002).

## 3.2 Features of the SISDS Methodology

Now, starting from the data level we will describe the SISDS method and discuss how it possesses the features listed so far. The formal definition explained here will allow us to implement a sound realization of the proposed method and make sure the data quality that is the key issue to the success to accomplish our objectives.

The building block in SISDS is a *data field* defined by a tuple  $\langle var, type, val, opts \rangle$  where *var* is the name of the data field, or *variable*, *type* is the type of the variable, *val* is its initial value, and *opts* is a list of options which may be empty. *type* is either

1. one of pre-defined types, such as integer, float, string, date, length, weight and volume <sup>4</sup>, or
2. if it is a nominal variable it is a set of possible values as multiple choices in menu-oriented understanding, ex.  $\{male, female\}$ ,  $\{primary, primer\}$ ,  $\{secondary, tertiary, not\ observed\ specifically, decreased, tertiary\}$  that is defined for the data field whose name is “peristalsis\_wave” that is in the data group numbered as 5 <sup>5</sup>.

For measurement data types, such as length, the initial value should also contain the unit of measurement, eg.  $1.2cm$  <sup>6</sup>. *opts* is a set of pairs of the form

$$\{\langle name_1, val_1 \rangle, \dots, \langle name_n, val_n \rangle\}$$

where  $name_i$  denotes the name of the  $i^{th}$  option and  $val_i$  is its value; typical options include the minimum, maximum and normal values of a variable.

A *data entry* is a unit of data request and encapsulates one or more variables; it is defined by a tuple  $\langle label, vars, defs \rangle$  where *label* is a unique identifier denoting the data entry, *vars* is a set of variable (i.e. data field) definitions and *defs* is a set of data request/view definitions (DRVDs). Each DRVD is a tuple of the form  $\langle type, lang, def \rangle$  where *type* denotes the type of the DRVD, *lang* denotes the language of the definition, and *def* is the body of the definition. The *lang* attribute enables multilingual reporting and allows different DRVDs be chosen for a data entry based on the specified language and rendered accordingly. An example that is rendered in two languages is given in Figure 4.9. The body of the definition is an arbitrary string with embedded variable references of the form  $\langle var, vals, opts \rangle$  where *var* is the name of the variable, *vals* is a set of mappings that map possible values of the variable to string counterparts (this is especially useful for nominal values), and *opts* is a set of options as in the definition of variables. Typical options include format specifiers to determine the rendering of the variable (such as, display format, default unit etc.). The general elements of formal specification of DRVD are summarized in Table 3.2. Note that, for consistency

---

<sup>4</sup>This list is not exhaustive and other types are also possible.

<sup>5</sup>see Appendix A.

<sup>6</sup>An example for the explanation is presented in Figure 4.17 as 2cm at the presentation level.

the definitions of all DRVDs of a data entry should contain references to the same set of variables. DRVDs are used by the presentation layer to render data entry forms or reports based on their *type*; for instance in nested tabular form ( Figure 5.4 and Figure 5.5) or in textual report format ( Figure 5.3). This gives rise to a unified view in which data collection and viewing are handled similarly. This is a property that makes the data entering screen cognitively as simple as the data viewing screen – all complete report may be seen in a free-text style even while entering structured data <sup>7</sup>, or preferably in an enumerated style (Figure 4.21), what you want to get as the final report is what you view while entering the data; this is certainly preferable by the health professionals.

A *data group* defined by a tuple  $\langle label, data-items, triggers \rangle$  groups together related items. The *label* attribute uniquely identifies the data group. *data-items* is a list of  $n$  items of the form  $\langle deg_1, deg_2, \dots, deg_n \rangle$  where  $deg_i$  is either a data entry as defined above or denotes a data group that is placed under the current data group (i.e. a child data group). Note that, it is this recursive definition that allows to build the hierarchical structure. *triggers* is a set of triggers that activate associated child data groups, as well as activate and display expert opinions and advices that are defined for various specific conditions. Each trigger in *triggers* is a pair of the form  $\langle cond, action \rangle$  where *cond* is a boolean expression with embedded variable references and *action* specifies an action to be executed when the condition holds, that is, the boolean expression evaluates to true. Some examples for conditions are given in the previous section while explaining logic level. The boolean expression may include arithmetic and logic operators, function calls, constants and variables references. The variable references in the boolean expression are of the form  $\langle label, var \rangle$  where *var* is the name of the variable and *label* is the identifier of the data entry that the variable belongs to. The variable references are not restricted to refer to the variables that belong to the data entries in *data-items*. While evaluating the boolean expression, the variable references are replaced with the current value (default value or that entered by the user) of the corresponding variables. Note that, the values of the variables with measurement data types must be normalized, i.e. converted into a common unit, before evaluation since the actual unit of such variables may be altered by the user during data entry. This can be done by automatically calling a unit conversion function while evaluating the condition expression. An *action* can be either a list of labels that denote the data groups to be activated, a message to be displayed, a diagnosis prediction or constraints on the values of other variables depending on the triggered condition. Once

---

<sup>7</sup>We would like to emphasize again that *free-text communication* is known to be the most effective way for *coordinating* a complex medical task (Sistrom, 2005; Garrod, 1998; Cimino & Patel, 2001)

a data group is activated, all of its data items (data entries and nested data groups that are not deactivated by any other condition) are displayed to user. Similarly, they become hidden when the data group is deactivated. It is important to note that in our formulation *cyclic activations* are not allowed, that is, a descendant of a data group can not activate or deactivate its parents via its triggers.

Finally, a *report* is a tuple  $\langle E, M, triggers \rangle$  where  $E$  is a set of consistent data groups, that is, all data groups referred in their trigger conditions and associated data entries exist in the report (i.e. are contained in  $E$ ),  $M$  is an ordered list of data group identifiers denoting the *main data groups* that are initially activated, and *triggers* is a set of report-wide triggers. For each identifier in  $M$  there must be a corresponding data group in  $E$ . An example for  $E$  is the entire esophagus report including all data entries and triggers presented in Appendix A. An example for  $M$  is the initial skeleton of the report including main data entries presented in Figure 5.1 as free-text style, and in Figure 5.2 as a nested structured tabular question/answer view. The main data groups constitute the initial skeleton of the report including normal or most common values. The report-wide triggers enable to both provide rule-based diagnosis and other suggestions to the user to automatically flag alarm conditions as well as rearrange the report based on the data entries. Furthermore, overall consistency of reports can be checked by these triggers.

To be more clear about what is described in this section, first, the general elements of formal specification of SISDS are summarized in Table 3.1: the header information consists of *definition* in which data elements are specified, *description of variables* in which each data element is defined one by one and *examples* in which a specific example is given to clarify the description of variables. Second, the relationship of data elements are depicted in Figure 3.2: the elements and hierarchical structure of the formal specification is organized from top to down as a report consists of data groups, data groups comprise data entries or/and new data groups, data entries contain data fields. And lastly, the interaction among the data, logic and presentation layers, and the user and the triggering process as described above is presented visually in Figure 3.3: data level and logic level constitute the backend of the report and these levels that are used to form the structures of medical reports are in the control of privileged users. On the other hand presentation level is the frontend of the application and used to compose medical reports. The contents of the reports are rearranged by the logic level in which report-wide triggers in terms of conditions are defined: a new data entry by the user may trigger a new data entry and/or a new data group. A new data entry may deactivate any active data entry or data group as well.

Table 3.1: Formulas of definitions in tabular.

definition	description of variables	examples
data field		
<var,type,val,opts>	var :the name of the data field type:the type of the variable val :the initial value of the variable opts:a list of options(name1,val1;...)	patient sex integer, nominal(M,F) male male,M;female,F
data entry		
<label,vars,defs>	label :a unique identifier vars :a set of variable definitions(i.e. data field), defs :a set of data DRVDs[type; lang; def(label; var; vals; opts)],	relief normal,not normal details are in Table 3.2 and in Table 4.1
data group		
<label; data-items; triggers>	label :a unique identifier data-items:a list of either data entries or data groups, triggers :a set of triggers,each of which is a pair of the form [cond(label; var)],[action],	data-entries-1 <deg1,deg2,...,degn> [relief == "not normal"], [trigger DRVD]
report		
<E,M,triggers>	E :a set of consistent data groups M :an ordered list of data group identifiers triggers:a set of report-wide triggers	all data entries main data entries(initial skeleton) triggers

Table 3.2: Formulas of DRVDs in tabular.

definition	description of variables	examples
DRVDs		
<type,lang,def>	<p>type :the type of the DRVD</p> <p>lang:the language of the definition,</p> <p>def :the body of the definition (var,vals,opts)</p>	<p>nested tabular form, in textual report format</p> <p>English, Turkish etc</p> <p>embedded variable references of the form</p>
def in DRVDs		
<var,vals,opts>	<p>var :the name of the variable</p> <p>vals :a set of mappings(ex. for nominal values),</p> <p>opts :a set of options(such as, display format, default unit etc.)</p>	<p>peristalsis_wave_1, peristalsis_wave_2</p> <p>primary, primer seconder</p> <p>kg to lbs ; the number of significant digits for numerical variables</p>



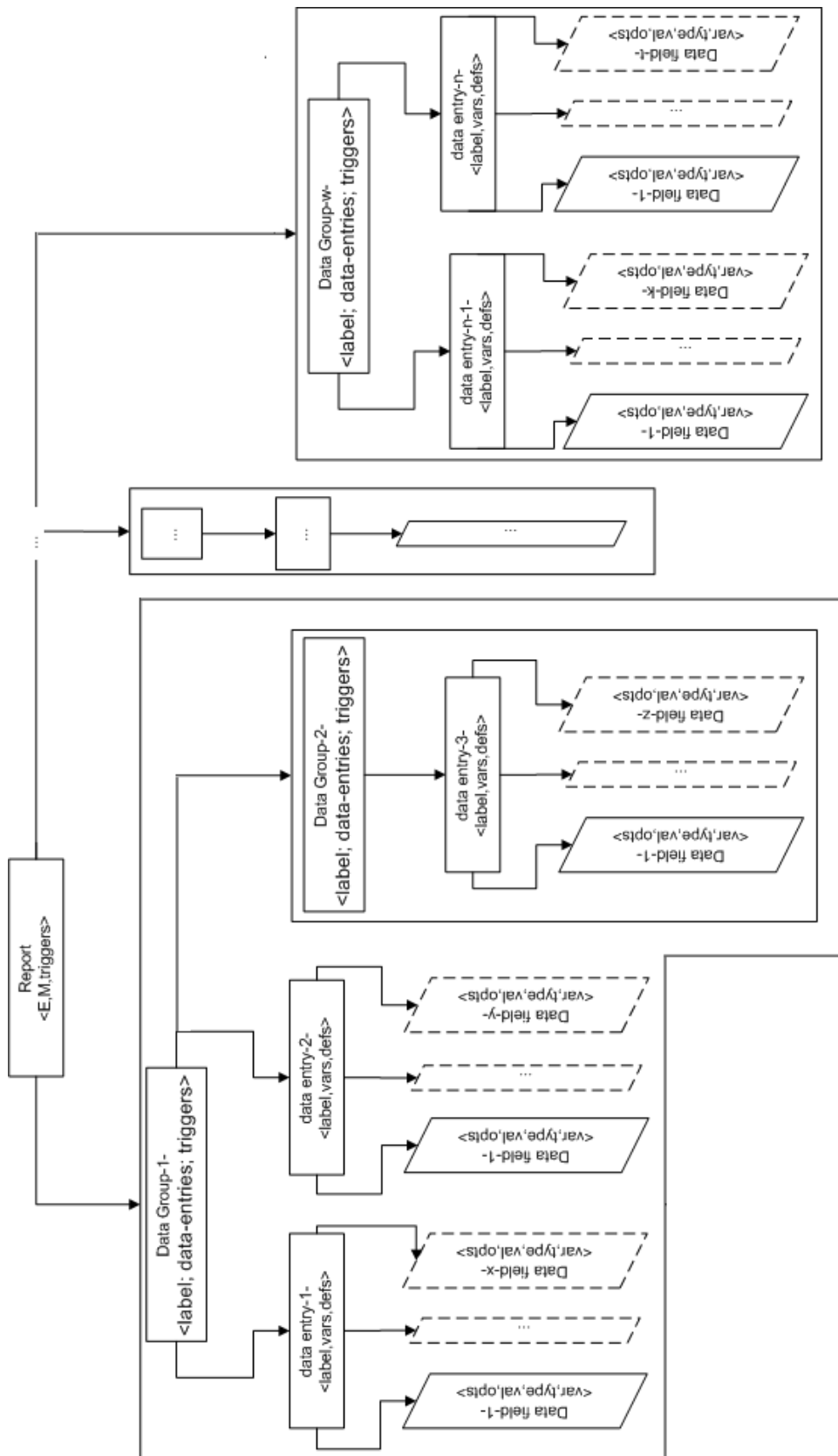

Figure 3.2: Elements and hierarchical structure of the formal specification of the SISDS method: A report consists of data groups; data groups comprise data entries or/and new data groups; data entries contain data fields.

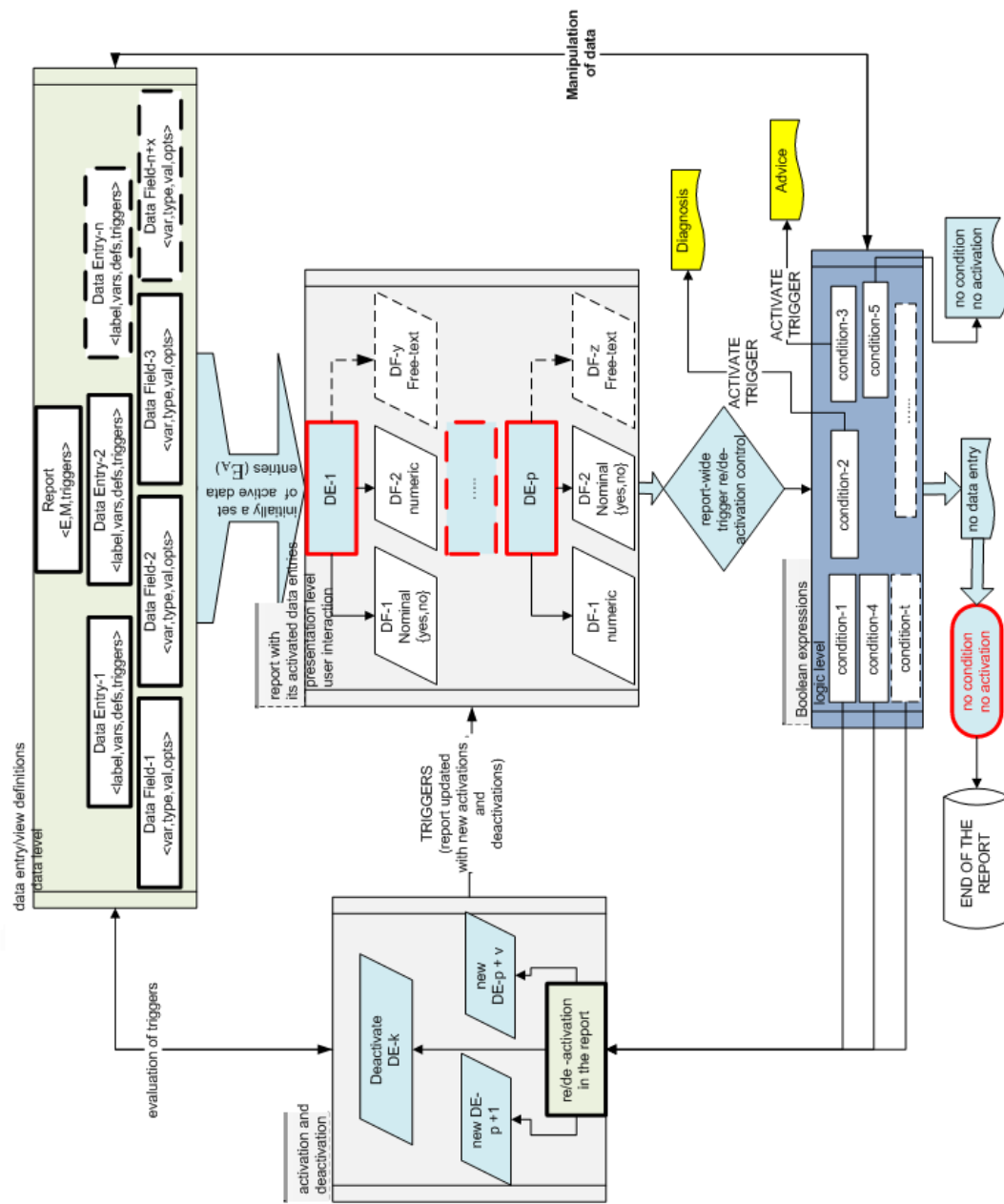

Figure 3.3: Interrelation among the layers of data, logic and presentation, and the user. All triggers are evaluated in terms of the specified conditions to rearrange the report or to generate some reminders such as diagnoses advices when the user enter a value for any data entry.

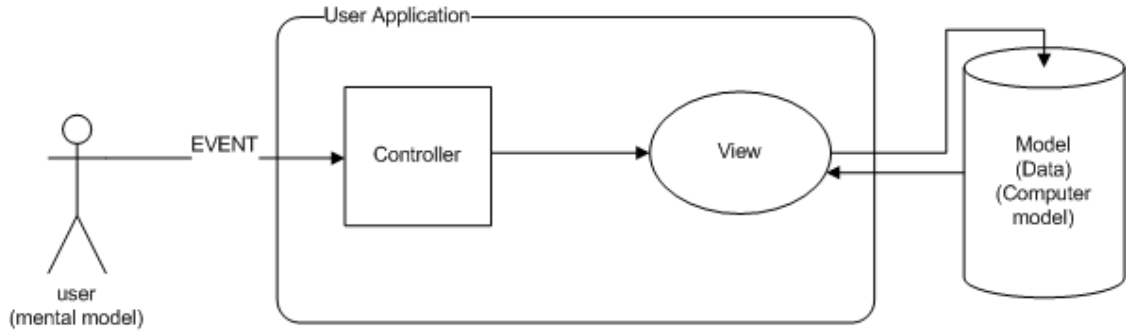

Figure 3.4: Diagram of Model-View-Controller: event causes a controller to change a model, or view, or both. Whenever a controller changes data in a model, view is automatically updated. Similarly, whenever a controller changes a view, for example, by revealing areas that were previously hidden, the view gets data from the underlying model to refresh itself. In short, event is passed to the controller on user demand; controller changes model or view; view get data from model; model updates view when data changes.

We would like to point out that several existing design patterns, most notably *model-view-controller (MVC)* architectural pattern fits well to this layering: MVC isolates business layer from presentation layer, resulting in an application where it is easier to permit independent development, testing and maintenance of each (Wikipedia, 2005d). MVC is essentially used to convert the human mental model to digital computer model and vice versa. The MVC abstraction can be graphically represented in Figure 3.4. In MVC, the model represents the information (the data) of the application. The view corresponds to elements of the user interface such as text, checkbox items, and so forth and the controller manages the communication of data and the business rules used to manipulate the data to and from the model. This mechanism not only prevents the cognitive overload, but also *unifies* the data entry and viewing phases<sup>8</sup>.

---

<sup>8</sup>For more detailed information about MVC design patterns we refer the interested reader to Hunt's book (J. Hunt, 2002).

# CHAPTER 4

## DESIGN AND IMPLEMENTATION OF THE SISDS METHODOLOGY

### 4.1 Architectural Design of the Web-based Prototype

In order to verify the viability of the proposed approach in which the mental model of human thinking is transformed into the computer model and vice versa computer model into mental model, a web-based prototype which adheres to the client-server architecture is established. Apache server is used as a web server. The web server renders the report for data entry or viewing, which is then displayed to the user by the web browser. The user interacts with the web browser (via Dynamic HTML and AJAX <sup>1</sup>) and his/her feedback (data entry or update, if any) is sent back to the web server for processing. The architecture of the SISDS methodology is depicted in Figure 4.1: a three-tier understanding, by which data, logic and presentation layers are separated from each other, is embedded in this architecture. In the figure, data level is displayed as DB where data are stored in a computer logic relational database. Presentation level is displayed as user site-1 and user site-2 where reports rendered together with requested report definitions and data by logic level according to the features of the SISDS methodology is displayed to users. Logic level is displayed as web server in the figure and it communicates with data and presentation levels to transform computer model to human logic model and vice-versa. MySQL relational database is employed at the data level to store data. The computer programming languages at the client/user site are javascript and dynamic html whereas at the server site php programming language is used.

---

<sup>1</sup>AJAX is a group of interrelated web development techniques used on the client-side to create interactive web applications: with Ajax, web applications can retrieve data from the server asynchronously in the background without interfering with the display and behavior of the existing page. The use of Ajax techniques has led to an increase in interactive or dynamic interfaces on web pages (Wikipedia, 2004a)

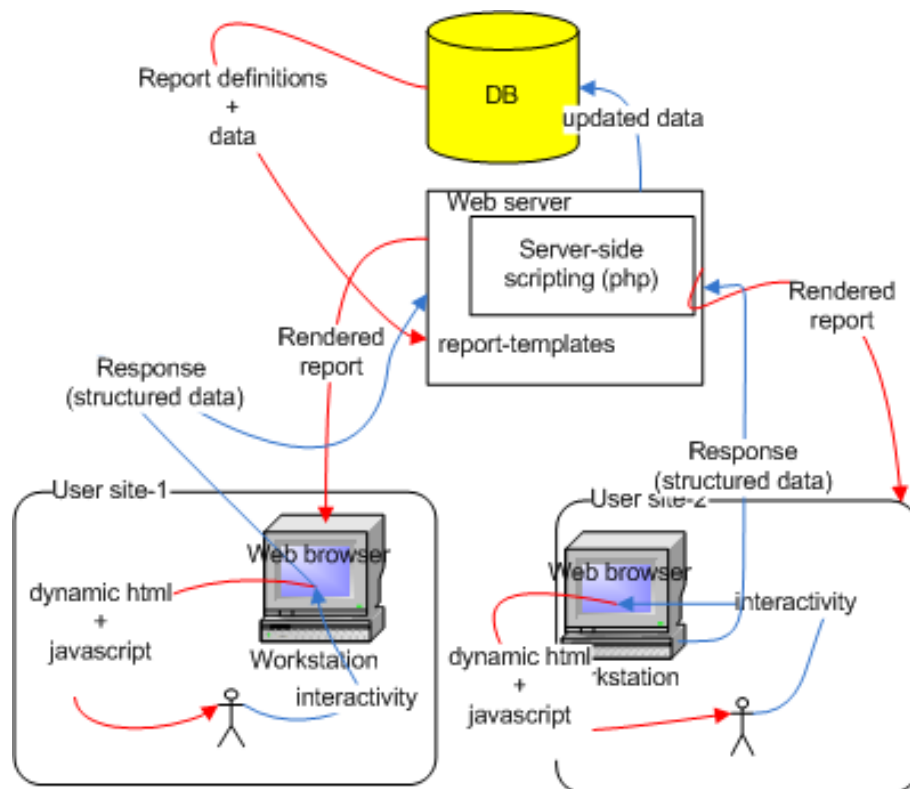

Figure 4.1: Architecture of the Web-based prototype: the web server renders the report for data entry or viewing, which is then displayed to the user by the web browser. The user interacts with the web browser (via Dynamic HTML and AJAX) and his/her feedback (data entry or update, if any) is sent back to the web server for processing.

DreamWeaver 8 as a software developing package is used as a coding platform by which implemented codes of the SISDS methodology was developed.

## 4.2 System Requirements

The minimum system requirements for operating the SISDS Methodology include a computer for a server with at least 512 megabytes of available RAM, 1 GHz CPU, Adobe Flash 8.0 or higher at the web server site for 10 users who are using the system at the same moment to generate an esophagus report with an approximate uploading size of 25 MB image data. The minimum system requirements for viewing and using this site is that 250 megabytes RAM and a screen resolution of 1024x768 or higher is recommended. In addition to that, the Web browsers of Internet Explorer 6.0 or higher, Mozilla FireFox 2.0 or higher, Apple Safari 2.0 or higher are supported. You may be required to install Adobe Flash or Acrobat to view supplemental material: Adobe Flash 8.0 or higher and Adobe Acrobat 7.0 or higher versions of those products are supported. Note that, the system requirements need to be increased as the number of users increases, and the size of the images and the number of slices, by which 3-D images are observed, rises.

For the experimental study mentioned in the next chapter, the SISDS Methodology runs at the server whose RAM is 1 GB, CPU is 2.33 GHz. The operating systems of Windows NT, 2000, XP are recommended and Microsoft Windows XP (Service Pack 2) is used in our implementation. ApacheFriends XAMPP (Basispaket) version 1.6.8 in which Apache 2.2.9 is supported was installed as to serve as a web server. 64 MB RAM and 200 MB free fixed disk space is required to operate apache server. The version of MySQL 5.0.67 is used as to store data as a relational database. The softwares of Adobe Flash 10.0 to show the uploading process and Mozilla FireFox 3.0.15 to run the SISDS system are loaded both in the server site and in the client-site computers <sup>2</sup>. The server was connected to a UPS system to serve 24 hour a day without being effected electricity cut. The cost of hardware and software (Mozilla FireFox and Adobe Flash are free softwares) is approximately \$750.

## 4.3 General Overview of the Established Methodology

The prototype has two main components. First of which is the back-end that allows privileged users to easily define and design report architecture and handles management tasks

---

<sup>2</sup>More detailed information to establish the system can be found in the “ReadMe” file put in the directory named “SISDS Methodology Software Codes”.

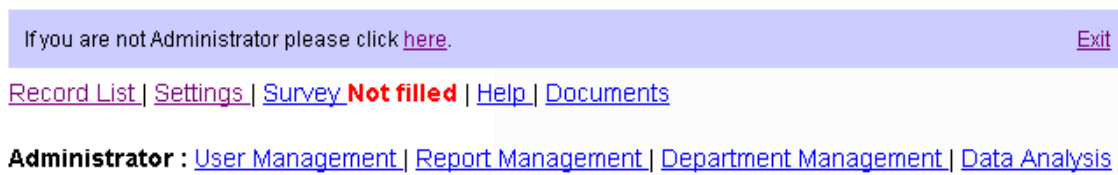

Figure 4.2: Header menu lists in all screens: The top menu list including record list, settings, survey, help, documents is displayed to every user whereas the lower menu list including user management, report management, department management, data analysis is just displayed to privileged users such as administrator.

such as user management, department management and data analysis using the definitions and collected data stored in a relational database to design the SISDS methodology. And the second of which is front-end that handles user and patient tasks such as user settings, questionnaire(survey), record list that is used to enter data for generating reports for patients to implement the SISDS methodology. The screenshot of the menu list that is placed at the top of each screen is displayed in Figure 4.2. The top menu list that includes record list, settings, survey, help, documents is displayed to every user whereas the lower menu list that includes user management, report management, department management, data analysis is just displayed to privileged users such as administrator. The top menu list constitutes the front-end of the methodology while the lower menu list constitutes the back-end of the methodology.

#### 4.4 Design of the Features of the Methodology: Back-end

The back-end operations to design the methodology are *user management*, *report management*, *department management* and *data analysis* as an administrator functions as displayed in Figure 4.2.

*User management* is used to authorize users to connect to the prototype. The screenshot of the user management (Figure 4.3) is displayed after the task of user management in Figure 4.2 is clicked: several definitions about users as login, password, name surname, type such as regular user or administrator, affiliation (institution), language specified for the language of the prototype for specific users and country are described by clicking new user ( Figure 4.4). The icon at the left, on which there is a pencil, is clicked to update the pre-defined user information as depicted in Figure 4.4.

The development of the system depends on the existence of information based on clear

Number of users<sup>28</sup> [New User](#)

	Name and Surname	Login	Type	Institution	Title	Country	Active
<input type="checkbox"/>	Administrator	admin	Administrator	Hacettepe	Assoc. Prof.	Turkey	Yes
<input type="checkbox"/>	Barış Diren	bdiren	Regular user	Medicana International Ankara Hastanesi	Prof.	Turkey	Yes
<input type="checkbox"/>	Demo User	demo	Administrator	ACME	Prof.	Turkey	No
<input type="checkbox"/>	Emin Alp Niron	eniron	Regular user	Başkent Üniversitesi	Prof.	Turkey	Yes
<input type="checkbox"/>	Ferhun Balkancı	fbalkanci	Regular user	Hacettepe Tıp Fakültesi	Prof.	Turkey	Yes
<input type="checkbox"/>	Kemal ARDA	karda	Administrator	Yenimahalle Onkoloji Hastanesi	Assoc. Prof.	Turkey	Yes
<input type="checkbox"/>	Uğur BOZLAR	ubozlar	Regular user	GATA	Assoc. Prof.	Turkey	Yes
<input type="checkbox"/>	Veysel AKGÜN	vakgün	Regular user	GATA	Doctor	Turkey	Yes

Figure 4.3: Screenshot of the user management task: new user is clicked to add new users to the system. The icon at the left, on which there is a pencil, is clicked to update the pre-defined user information. The sign, X, placed at the most left of the created users is performed to make users inactive.

**Login:**

**Password:**

**Name and Surname:**

**Type:**

**Institution:**

**Title:**

**Language:**

**Country:**

Figure 4.4: Screenshot to create new user or edit pre-created users.



specifies domain terminologies, functional hierarchies and decision rules. To build a perfect application having all needed details or data at the beginning is very difficult since medical information is increasing logarithmically day by day. It is important for professionals to generate architecture of their report formats themselves, a process easily accomplished by using the proposed application that provides an architectural design to generate medical report formats to address such concerns. Users are able to easily design and modify reports specific to their domains, as proposed by Siström (Siström, 2005), with an interface designed in accordance with the characteristics and the formal specification of the methodology. Consequently, an extensive computer knowledge is not required to design, define and edit report formats. Therefore, there is no dependency on either a computer expert or a commercial firm to design report architecture, which is a matter of cost consideration, one of the difficulties to acquire information capture technology (Waegemann et al., 2002; Sim & Rennels, 1995). Report management in Figure 4.2 is used to realize these tasks. The screenshots of the management of report formats are displayed in Figure 4.5 and Figure 4.6. With these screens, the privileged users can design and edit nested data items in a hierarchy to form a complete medical report in accordance with the features of the SISDS methodology mentioned in Section 3.2.

Updates are done by using the edit buttons at the left of each item in Figure 4.5. The specified sections may be de/activated by either marking the box named as “Active” and placed at the left of sections or canceling mark in the box with a click.

In realizing the abstract variable, data entry and data group definitions explained in the previous Chapter 3, we opted to use a user-friendly (human-readable) textual BNF notation <sup>3</sup> with a simple syntax. The syntax of this notation is presented in Table 4.1 together with some examples. The sections in curly brackets are optional. Each variable has a name as well as a type. For nominal variables, the type attribute is a comma separated list of possible values of the variable, such as *male, female*. An optional initial value might as well be defined for each variable. Every data entry has a unique number indicating itself and the data fields belonging to the data entries can be referred in dotted notation

---

<sup>3</sup>In computer science, Backus Naur Form, BNF, is a metasyntax used to express context free grammars: that is, a formal way to describe formal languages: John Backus and Peter Naur developed a context free grammar to define the syntax of a programming language by using two sets of rules: i.e., lexical rules and syntactic rules (Wikipedia, 2005a). BNF is widely used as a notation for the grammars of computer programming languages, instruction sets and communication protocols, as well as a notation for representing parts of natural language grammars (Wikipedia, 2005a).

## Edit Report

Title:	Esophagus (Özafagus)
Department:	Radiology
URL:	http://www.cetinsengoz.com/main/resimlermenu/uzendoskop/mide/emr.htm
<input type="button" value="Save"/>	

## Message Triggers

1.	Condition: [113.extravasating] == "yoktur" && [115.transition] == "bekleyerek olmuştur"
	Message: Özafagus bölgesinde darlık olabilir.
	Message: There may be a narrowness in the esophagus.
2.	Condition:
	Message:
	Message:

## Questions

- [#11] Hastanın pozisyonu nasıldır? [position|yatarak prone oblik,erekt sol oblik,erekt sol lateral,erekt sağ lateral,semierekt,supin,trandelenburg,yatarak ve ayakta:erekt sol lateral]dir.  
How is the position of the patient? = [position|prone oblique,erect left oblique,erect left lateral,erect right lateral ,semierect,supin,trandelenburg,lie-down and erect].  
Hastanın pozisyonu [position]dir.  
The position of the patient is [position|prone oblique,erect left oblique,erect left lateral,erect right lateral ,semierect,supin,trandelenburg,lie-down and erect]
- [#13] Kontrast maddenin lümen dışına kaçağı var mıdır? = [extravasating|yoktur,vardır,yoktur,norma=yoktur]  
Is there leakage of contrast media out of the lumen? = [extravasating|There isn't,There is].  
Kontrast maddenin lümen dışına kaçağı [extravasating].  
[extravasating|There isn't,There is] leakage of contrast media out of the lumen.  
**[extravasating] == "vardır"**
  - [#14] Kaçağın olduğu özafagus bölgesi neresidir? = [section|proksimal 1/3 özafagus,orta 1/3 özafagus,distal 1/3 özafagus,0m özafagus,proksimal 1/3 özafagus,norma=yok]tur.  
Which section is the section of the extravasating? = [section|1/3 esophagus,middle 1/3 esophagus,distal 1/3 esophagus,whole esophagus].  
Kaçağın olduğu özafagus bölgesi [section]tur.  
The section of the extravasating is [section|1/3 esophagus,middle 1/3 esophagus,distal 1/3 esophagus,whole esophagus].
- [#15] Kontrast maddenin özafagustan mideye geçişi nasıldır? = [transition|beklemeden normal hızla olmuştur,bekleyerek olmuştur,bekleyerek belirli seviye oluştuktan sonra olmuştur,olmamıştır].  
How is the transition of the contrast media from the esophagus to stomach? = [transition|as normal without delay , delayed transition,happens after a level occured and with delay , doesn't happen].  
Kontrast maddenin özafagustan mideye geçişi [transition].  
The transition of the contrast media from the esophagus to stomach is [transition|as normal without delay , delayed transition happens after a level occured and with delay , doesn't happen].  
**[transition] == "bekleyerek belirli seviye oluştuktan sonra olmuştur"**
  - [#16] Görülen seviye nasıldır? = [level|1/3 üst özafagusta,1/3 orta özafagusta,1/3 alt özafagusta,tüm özafagus boyunca:1/3 üst özafagusta,norma=yok]dir.  
What is the site of the level? = [level|1/3 upper esophagus,1/3 lower esophagus,whole esophagus].  
Görülen seviye [level]dir.  
The site of the level is [level|1/3 upper esophagus,1/3 middle esophagus,1/3 lower esophagus,whole esophagus].

Figure 4.5: User interface to define and edit a report: (1) The main attributes of the report, such as its title and the associated department, (2) Report-wide notifications and diagnosis suggestions, and (3) an example trigger. The data groups are listed under the “Questions” section. (4) shows a main data group of the report that has a child data group as indicated by (5), the trigger condition of the child data group is displayed in the shaded area.

**Edit Question**

1 **Definition** : Özofagus mukozal rölyef nedir? - [relief|normal,normal degi|normal|normal-normal]

2 **Definition (EN)** : How is the mucosal relief of the esophagus? - [relief|normal|not normal]

**Text** : Özofagusta mukozal rölyef [relief]dir.

**Text (EN)** : The mucosal relief of the esophagus is [relief|normal|not normal].

**Active** :

**Sub-question Blocks** 3

**Block 1**

**Condition** : [relief] == "normal degi" 4

**Active** :

**Sub-questions** 5

#	Active	Definition	Text	Sub-questions
1.	<input checked="" type="checkbox"/>	Özofagusta normal olmayan rölyef nedir? = [topography kalkinligi]g mukozal kıvrımlar görünümde,retiküler mukozal patern görünümde,mukozal nodül görünümde, ince transvers mukozal çizgiler (örne özofagus) görünümde,kalkinligi mukozal kıvrımlar görünümde normal-yoktur.	Özofagusta normal olmayan rölyef [topography]dir.	0

Add sub-questions

**Block 2**

**Condition** : [relief] == "normal degi"

**Active** :

**Sub-questions**

#	Active	Definition	Text	Sub-questions
1.	<input checked="" type="checkbox"/>	Normal olmayan rölyef hangi seviyededir? = [relief_level proksimal 1/3 özofagus,orta 1/3 özofagus,distal 1/3 özofagus,tüm özofagus,proksimal + orta 1/3 özofagus,proksimal + distal 1/3 özofagus,orta + distal 1/3 özofagus,proksimal 1/3 özofagus;normal yok]tur.	Normal olmayan rölyef hangi seviyededir? = [relief_level]tur.	0

Add sub-questions

**New Sub-question Block**

**Condition** :

Add sub-questions

Save 6

Figure 4.6: User interface to define and edit a data group (question): In the web-based prototype, each data group is associated with a single data entry (1) with multiple languages (2). Each data group may have multiple child data groups (3). Each child data group has a specific trigger condition (4) that activates it and data items that are defined under it (5). The user can add a new child data group (sub-question) by defining its trigger condition (6) and then edit it using the same interface.

Table 4.1: Syntax of variable, data entry/view definitions and trigger conditions in modified BNF notation and some examples. Entities within curly brackets are optional. In the first example, note the change in the position of the variable in the Turkish version.

```

⟨variable⟩→⟨name⟩ = ⟨type⟩ { : ⟨value⟩ } { ; ⟨opts⟩ }
⟨type⟩→int|float|string|date|length|area|volume|⟨nominal⟩
⟨nominal⟩→⟨value list⟩
⟨value list⟩→⟨value⟩|⟨value⟩ , ⟨value list⟩
⟨opts⟩→⟨opt⟩ = ⟨value⟩|⟨opt⟩ = ⟨value⟩ , ⟨opts⟩

⟨defn⟩→⟨entity⟩|⟨entity⟩ ⟨defn⟩
⟨entity⟩→⟨string literal⟩|⟨var ref⟩
⟨var ref⟩→ [ { ⟨label⟩ . } ⟨name⟩ { : ⟨value map⟩ } { ; ⟨opts⟩ } ]
⟨value map⟩→⟨value⟩ = ⟨string literal⟩|⟨value⟩ = ⟨string literal⟩ , ⟨value map⟩

segment_length = length : 2cm ; min = 0cm, max = 10cm
  What is the length of the narrow segment? [segment_length]
  The length of the narrow segment is [segment_length].
  Dar segment genişliği [segment_length]’dir. (in Turkish)

defect = smooth,regular,circular : smooth ; normal = regular
  The filling defect is in the shape of [defect:smooth=smooth linear structure,
circular=circular modular,regular=regular linear structure].
  Dolma defekti [defect:düz=düz linear yapıda,
yuvarlak=yuvarlak modüler,düzenli=düzenli linear yapıda] dır. (in Turkish)

([1.segment_length] > 5 and [segment_length] < 7) or [defect] = “circular”

```

as *[the unique number of the data entry].[the name of the data variable]*. The options are defined as a list of the form *[the name of the option]=[the value of the option]*. The data request/view definitions, *defn*, are arbitrary strings that contain variables references, *var ref*. For nominal variables, the variable references in DRVDs may contain value mappings that map possible values of the variable into textual form depending on the language of the DRVD. For instance, the variable reference *5.sex:male=bay, female=bayan* indicates that the *sex* variable belonging to the data entry with label 5 should be displayed as *bay* or *bayan* depending on its value. Bay and bayan refer to male and female in English respectively. The optional *opts* attribute allows to specify how the variable should be rendered, ex. the number of significant digits for numerical variables. The trigger conditions are also defined using this notation as boolean expressions such as *([1.segment\_length]> 5 and [segment\_length] < 7)* or *[defect] = "circular"*. The data entered by the user are stored in a database in a structured and normalized format. The database tables and the relations between them are presented in Appendix C.

Some possible alerts or diagnoses to be triggered can be defined in some expressions. These alerts could be triggered if the designated data entries are compatible with pre-defined condition as in the defined ranges or with the defined value as a boolean expression that is a mathematical set with operations whose rules are any of various equivalent systems (Babylon, 2000)(Boolean expressions may be defined by using mathematical operations such as =, >, <, <>, etc). Thus, laboratory professionals are notified of the potential problem or diagnosis and guided through report generation with great concentration while examining images or patients. In this sense, data quality is increased in medical reports. Simple computerized algorithms that generate reminders, alerts, or other information, and protocols that incorporate more complex rules reduce the clinical decision error rate (D. Bell & Greenes, 1994).

From a conceptual point of view, our structured design with interactivity looks like a tree with branches growing from a stem such that the branches collapse and expand as needed in terms of the request from the user, the data entries in the main data groups being the initially expanded branches. A dynamic hierarchy of *sections* is built as related data entries logically follow-up depending on the defined conditions. The stored data in the database can be extracted in various formats that can be easily processed by other applications (such as statistical packages or spreadsheet applications). The screen of data analysis (Figure 4.7) to filter data could be reached by clicking the task of data analyzing in Figure 4.2: at this screen, data could be filtered for available report types to build DDSS for specific types by

Figure 4.7: Screen to filter collected data in accordance with some criterions to make research or to build DDSS: data could be filtered to be evaluated either by WEKA tool if the section of for classification is checked or by other applications such as statistical packages (ex. SPSS) or spreadsheet applications(ex. Excel) if the section of CVS formatted is checked. Data could be filtered for available report types to build DDSS for specific types by choosing the related items in the combo box named as report type. Data could be filtered by age intervals as well as by sexes. The button named as download is clicked to draw the data according to specified criterions.

Number of departments: 3 [New Department](#)

	Title	Number of Reports	Active
	Oncology	0	Evet
	Pathology	0	Evet
	Radiology	5	Evet

Figure 4.8: Screen to add new departments.

choosing the related items in the combo box named as report type. Data could be filtered by age intervals as well as by sexes and the button named as download is clicked to draw the data according to specified criterions. The filtered data are easy-to-use promptly to construct DSSs without time consuming preprocessing steps thanks to the features mentioned in the previous Chapter 3, the structured format and the normalized data relations at the data level. A detailed example of building a DDSS for the diagnostic code of K22.4 is presented in Section 5.3 in next chapter.

The screen of department management could be reached by clicking the task of department management in Figure 4.2 : new departments, in which new report formats are formed, could be added by clicking the task of new department in the activated screen in Figure 4.8.

The back-end of the application has several sections to handle back-end tasks<sup>4</sup>. Reports can easily be generated in different languages and a prompt version of any generated report is transformed into another language without any further processing given that the corre-

<sup>4</sup>The prototype can be tested for hands-on experience after installing the application, all needed installation codes and related software are put in the DVD attached to the thesis.

Hastanın pozisyonu yatarak **prone obliktir**. Oral yoldan kullanılan kontrast madde **baryum maddesidir**. Kontrast maddenin lümen dışına kaçıışı **vardır**. Kaçağın olduğu özafagus bölgesi proksimal **1/3 özafagustur**. Kontrast maddenin özofagustan mideye geçişi **beklemeden normal hızla olmuştur**. Kontrast madde geçişi sırasında görülen peristaltik dalganın özelliği **primerdir**. Kontrast madde geçişi sırasında özafagusta belirgin genişleme göstermeyen, dar (13 mm den daha az) bölüm **yok**...

The position of the patient is **prone oblique**. The contrast media used in oral way is **barium**. **There is** leakage of contrast media out of the lumen. The section of the extravasating is **1/3 esophagus**. The transition of the contrast media from the esophagus to stomach is **as normal without delay**. The feature of the peristalsis wave during the transition of the contrast media is **primary**. **There isn't** narrowness without a clear expansion in the esophagus during the transition of the contrast media...

Figure 4.9: Free text version of the same report in two languages, Turkish (top) and English (bottom): a prompt version of any generated report can be transformed into another language without any further processing given that the corresponding data request/view definitions are available in that language.

3.  [#113] Kontrast maddenin lümen dışına kaçıışı var mıdır? = [extravasating|yoktur,vardır;yoktur;normal=yoktur]  
Is there leakage of contrast media out of the lumen? = [extravasating|There isn't,There is].  
Kontrast maddenin lümen dışına kaçıışı [extravasating].  
[extravasating|There isn't,There is] leakage of contrast media out of the lumen.

Figure 4.10: An example of the definitions of report sections: the definition of the third data entry in esophagus report format. The term extravasating is the parameter. In Turkish, yoktur and vardır are the nominal values of the parameter. The default value specified after colon put at the end of the nominal values is yoktur. The normal value specified after semicolon put at the end of the default value is yoktur. There is a mapping function from Turkish definitions to other languages according to the sequences of the defined values. For instance, for English, the nominal values are “there isn’t”, which refers to the nominal value of “yoktur” in Turkish, and “there is” that refers to the nominal value of “vardır” in Turkish.

sponding data request/view definitions are available in that language (Figure 4.9). Language translation for reports are performed according to the syntax mentioned in Table 4.1. For instance, the third data entry in the esophagus report presented in Figure 4.9, “Kontrast maddenin lümen dışına kaçıışı *vardır.*”, is translated into English language as “*There is leakage of contrast media out of the lumen.*”. This section is defined as displayed in Figure 4.10: there is a mapping function from Turkish definitions to other languages according to the sequences of the defined values. For instance, for English, the nominal values are “there isn’t”, which refers to the nominal value of “yoktur” in Turkish, and “there is” that refers to the nominal value of “vardır” in Turkish. Parameters could be placed in between any parts of the sentence either in Turkish or in other languages to form a meaningful sentence. In this respect, how the instantaneous translation of esophagus reports is transformed may be come out better in Appendix A for more examples.

The sentences, the words, the messages, button names etc. on the screens of the web-based application (different from report format for which definitions are done in DRVDs) can be translated into other languages by a mapping function in terms of the definition specified in a file as depicted in Figure 4.11. The terms in the main language that is specified as Turkish defined on the screens of the application are captured in the file automatically to be defined for other languages by privileged users. Translations and updates can be done easily for any language in the file by privileged users. The application serves the user in the language which is specified in the language settings of the user.

## 4.5 Implementation of the Designed Features of the Methodology: Front-end

The menu list of the front-end operations to interact with the methodology are *record list*, *user settings*, *questionnaire (survey)*, *help* and *documents* as a regular user functions as displayed in Figure 4.2.

System operation begins with the professional entering his or her authorized username and password to connect to the system. The screen of *record list* is displayed as a default page: header information consists of the date (of admission), (admission) number, patient(’s name), sex, age, user (name who lastly updated the record), (highlighted name of image) files, # of images (as the number of slices), (the kind of the) report, (the status of report whether it is) closed and (the status of whether it is) deleted as presented in Figure 4.12. This list of patients can be filtered by means of a filter section located above the patient list



Özgün dizgi	Çeviri
Hasta ID boş olamaz.	Patient ID cannot be empty.
Girilen TCK numarasına sahip kayıt bulunamadı.	No record found with given patient ID.
Hasta adı boş olamaz.	Patient name cannot be empty.
Hasta soyadı boş olamaz.	Patient surname cannot be empty.
Doğum tarihi gün/ay/yıl şeklinde olmalıdır.	Birth date must be in DD/MM/YYYY format.
Doğum tarihi geçersiz.	Invalid birth date.
İşlem tarihi gün/ay/yıl şeklinde olmalıdır.	Date must be in DD/MM/YYYY format.
İşlem tarihi geçersiz.	Invalid date.
Cinsiyet geçersiz.	Invalid gender.
Dosya yüklemesi başarısız.	File upload failed.
%s değilseniz lütfen <a href="logout.php">tıklayın</a>.	If you are not %s please click <a href="logout.php">here</a>.
Çıkış	Exit
Kayıt Listesi	Record List
Ayarlar	Settings
Anket	Survey
Doldurulmamıştır	Not filled
Yardım	Help
Dökümanlar	Documents
Yönetici	Administrator
Kullanıcı Yönetimi	User Management
Rapor Yönetimi	Report Management
Bölüm Yönetimi	Department Management
Bilgi Aktar	Data Analysis
Yeni İşlem	New Record
Aşağıda listelenmiş olan hataları düzeltmeniz gerekmektedir	Please correct the following error(s)
Hasta ID (TCK No)	Patient ID
Yükle	Upload
Hasta Adı	Patient Name
Hasta Soyadı	Patient Surname
Doğum Tarihi	Birth Date
(GG/AA/YYYY)	(DD/MM/YYYY)
Cinsiyet	Gender
İşlem Tarihi	Date
İşlem Türü	Type
Ön Tanı	Pre-diagnosis
Klinik Bilgi	Clinic Information
Açıklama	Description
Rapor	Report
Fotoğraf	Photo
Kullanıcı	User
Ekle	Add
* ile işaretli alanların doldurulması zorunludur!	Fields marked by * are required.
Başlık boş olamaz.	Title cannot be empty.
Yeni Bölüm	New Department
Başlık	Title

Hasta Soyadı

Patient Surname

Figure 4.11: An example for the language mapping file: the application uses the language which is specified in the language settings of the user. Translations and updates can be done for any language in the file by privileged users. The terms in the main language that is specified as Turkish defined on the screens of the application are captured in the file automatically to be defined for other languages by privileged users.





































	Date	#	Patient	C	Age	Type	User	File(s)	# of Images	Report	Closed	
1.	 	14/07/2009	001 <a href="#">N.A.</a>	M	42	G.H	dr1 ( Last Update: <a href="#">001.rar</a> )	-	-	Esophagus (Ozafagus)		   
2.	 	14/07/2009	002 <a href="#">H.A.</a>	F	49	G.H	dr1 ( Last Update: <a href="#">002.rar</a> )	-	-	Esophagus (Ozafagus)		    
3.	 	14/07/2009	003 <a href="#">M.A.</a>	F	51	G.H	dr1 ( Last Update: <a href="#">003.rar</a> )	-	-	Esophagus (Ozafagus)		   
4.	 	14/07/2009	004 <a href="#">M.A.</a>	F	47		dr1 ( Last Update: <a href="#">004.rar</a> )	-	-	Esophagus (Ozafagus)		   
5.	 	14/07/2009	005 <a href="#">G.B.</a>	M	61	G.H	dr1 ( Last Update: <a href="#">005.rar</a> ) Administrator )	-	-	Esophagus (Ozafagus)		   

Figure 4.12: Screenshot of the list of patients: The sign of X at the most left is used to delete the related record. The box at the left on which there is a pencil is employed to update the personal information and order information inserted by physicians of the related patient. There are four boxes at the right to click: the first of which is used to generate medical report. The second box is to print out the generated report in free-text form while the third is to print out the report in structured nested hierarchical form, and the last box is employed to upload images or files that are related to the generated reports.

as exemplified in Figure 4.13. The box at the left on which there is a pencil in Figure 4.12 is employed to update the personal information and order information inserted by physicians of the related patient as presented in Figure 4.14. This page is also used for clinicians to order medical reports either to update any patient ordering information or to add a new order belonging to a patient.

The workflow and the interaction of the user with the front-end to generate medical reports is depicted in Figure 4.15 step by step in an algorithmic perceptiveness: all possible problems or symptoms are examined in a hierarchy. A condition may trigger and/or prune data elements such as data entries and data groups. Subsequent symptom- or problem-driven data elements are pushed forward to dig out other more detailed findings related to the main data entries. An architectural hierarchy of data elements is built. Only problematic parts could be examined in detail and other unrelated data elements could be eliminated with the algorithm to save time, increase concentration, prevent “lesion blindness”<sup>5</sup>, and avoid inefficiency and cognitive overload.

The main novelty of this particular implementation is a free-text like data entry facility with *inline editing*. As we mentioned in the previous chapters, free-text is the most natural

<sup>5</sup>The term of “lesion blindness” is the condition in which a professional could not see other pertinent details while concentrating on a specific subject (lesion, etc.).

Filter										
Patient:	Kaya	Kuru	User:	Assoc. Prof. Uğur BOZLAR	Gender:	Male	Age:	12	-	20
Report:	None	Report Type:	Esophagus (Özafagus)	Date:	10/10/2009	-	15/10/2009	ICD10:	None	Display

Figure 4.13: An example of the filter section to list the patients in several categories: the user combo box lists all the registered users by means of their affiliations to list the patients assigned to specific users; the gender combo box has the nominal values of all, male, female and other to bring up the list of the patients belonging to specific sexes; age intervals can be specified; report combo box is used to list the patients by means of whether whose reports are generated previously (the nominal value of present is chosen) or not (the nominal value of none is chosen); the combo box named as report type is designed to categorize the patients by means of their report types ordered by physicians such as esophagus or colon; the intervals of order dates could be specified; whether the patient is diagnosed with an ICD-10 code (the nominal value of present) or not (none) could be listed by the ICD-10 combo box, or the nominal value of all is chosen to list the patient in both categories.

way for data entry where the entered data directly correspond to the content of the final product (i.e. report). One way to ensure this in structure data entry is to let the user see the resulting report while *still entering data*. Although this can be accomplished by following a split view approach as displayed in Figure 4.16 <sup>6</sup>, i.e. having two separate data entry and report views and updating the second one as the user makes modifications in the first one, this is not cognitively appealing as the user has to go back and forth between different views, increasing cognitive load. The solution that we offer is to use inline editing, which is to present the report in a single view but allow the users to directly manipulate the data on the screen simply by clicking on data fields which are displayed as hyperlinks (Figure 4.17): The predefined nominal values are displayed for data fields when the user clicks any hyperlink, such as to enter the narrowness as “*there is*” or “*there isn’t*”. A text entry or a numeric data entry field is displayed if there isn’t any predefined nominal value as “*the length of the narrow segment*” entered as 2 cm. As the user changes the values of variables, the contents of the report are also rearranged automatically according to predefined trigger conditions. The trigger conditions are evaluated by a compact interpreter written in Javascript and runs on the client side. The report as a whole could be followed in this way. While evaluating the boolean expressions, the interpreter replaces the variable references by the current values of the corresponding variables and also performs automatic unit conversion if necessary. The interpreter also notifies the user when the conditions associated with the report-wide

<sup>6</sup>This example is taken from our previous study.

If you are not Uğur BOZLAR please click [here](#).

[Record List](#) | [Settings](#) | [Survey](#) | [Help](#) | [Documents](#)

## Edit Record

<b>Patient ID*:</b>	<input type="text" value="3000243545"/>
<b>Patient Name*:</b>	<input type="text" value="İ."/>
<b>Patient Surname*:</b>	<input type="text" value="Ö."/>
<b>Birth Date*:</b>	<input type="text" value="01/01/1950"/> (DD/MM/YYYY)
<b>Gender*:</b>	Male <input type="button" value="v"/>
<b>Date*:</b>	<input type="text" value="27/03/2003"/> (DD/MM/YYYY)
<b>Type:</b>	<input type="text" value="GH"/>
<b>Pre-diagnosis:</b>	<input type="text"/>
<b>Clinic Information:</b>	<input type="text" value="Klinik Tanısı Yok"/>
<b>Description:</b>	<input type="text"/>
<b>Report:</b>	Esophagus (Özafagus) <input type="button" value="v"/>
<b>Photo:</b>	<input type="text" value="Gözet..."/> <input type="checkbox"/> Load the current photo.
<b>Closed:</b>	Hayır <input type="button" value="v"/>
	<input type="button" value="Save"/>

Fields marked by \* are required.

Figure 4.14: Patient information screen for clinicians to order medical reports to update any patient ordering information or to add a new order belonging to a patient: clinicians are expected to insert pre-diagnosis, clinical information, description together with the type of medical reporting.

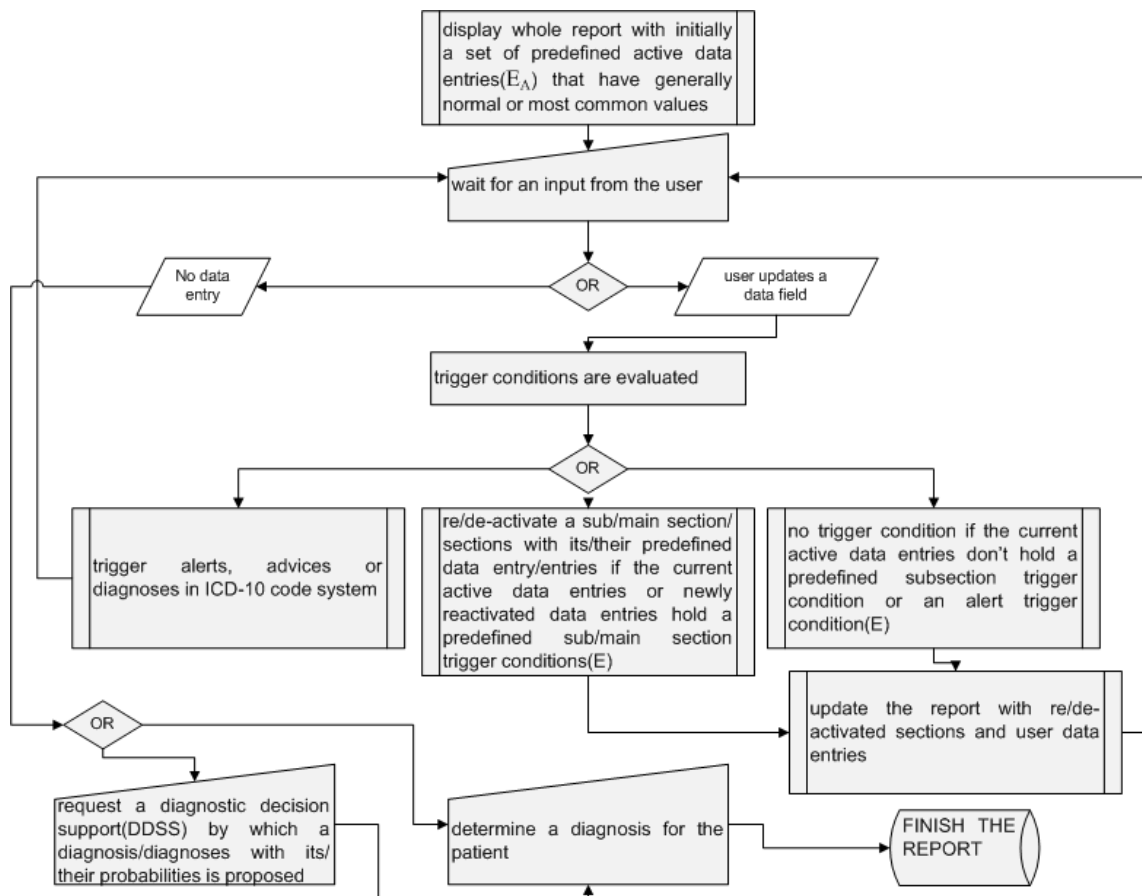

Figure 4.15: Interaction of the user with the front-end presentation layer to generate medical reports: The report collapse and expand as needed in terms of the request from the user, data entries in the main data groups being the initially expanded branches.

**Hasta Bilgileri**  
Hasta NO(T.C.No): 29551562386  
Hasta Adı: KAYA  
Hasta Soyadı: KURU  
Hasta Cinsiyeti: Erkek  
Doğum Tarihi: 18. 02. 1971  
Posta Adresi: kkuru2002@yahoo.com

**Doktor Bilgileri**  
Bilim Dalı: RADYODİAGNOSTİK RADYOLOJİ  
Hazırlayan Doktor: KEMAL ARDA  
Doktor Ünvanı: Doç Tbp

**Haber Bilgileri**  
Rapor No:   
Rapor Tarihi: 06. 03. 2008

**Soru Bilgileri**  
Rapor Alanı: KOLON GRAFİSİ  
Soru No: 2  
Soru Getir: Pozisyon nasıldır  
Cevap Girişi: düzenlidir

**Mesai vazamı Tanı Bilgileri Kısmı**

kod	acıklama	etkinlik
K59.3	Megakolon başka yerde sınırlanmış	95
K56.7	İeus tanımlanmamış	100

**Rapor Açıklaması**  
REKTUM segmentinin çapı 3 cm dir!!!. Pozisyon düzenlidir . Konturlar düzenlidir . Darlık yoktur . Mukozal yapı düzenlidir . SIGMOID KOLON segmentinin çapı 5 cm dir. Pozisyon anomali vardır !!! . Yerleşimi Laterale dir !!! . Konturlar düzenlidir . Darlık yoktur . Mukozal yapı düzenlidir . İNEN KOLON segmentinin çapı 5 cm dir. Pozisyon düzenlidir . Konturlar düzenlidir . Darlık yoktur . Mukozal yapı düzenlidir . SPLENİK FLEKSURA segmentinin çapı 5 cm dir. Pozisyon düzenlidir . Konturlar düzenlidir . Darlık yoktur . Mukozal yapı düzenlidir . TRANSVERS KOLON segmentinin çapı 5 cm dir. Pozisyon düzenlidir . Konturlar düzenlidir . Darlık yoktur . Mukozal yapı düzenlidir . HEPATİK FLEKSURA segmentinin çapı 5 cm dir. Pozisyon düzenlidir . Konturlar düzenlidir . Darlık yoktur . Mukozal yapı düzenlidir . ÇIKAN KOLON segmentinin çapı 5 cm dir. Pozisyon düzenlidir . Konturlar düzenlidir . Darlık yoktur . Mukozal yapı düzenlidir . ÇEKUM segmentinin çapı 5 cm dir. Pozisyon düzenlidir . Konturlar düzenlidir . Darlık yoktur . Mukozal yapı düzenlidir .

Figure 4.16: A split view approach having two separate data entry and report views to accomplish to compose an interactive medical reporting: the report is written in the area of “Rapor Açıklaması” automatically as a text version while questions are being answered by professionals in the section of “Soru Bilgileri” one by one. The report as a whole could be followed in the section of “Rapor Açıklaması”. Walking through answered questions easily is necessary for the acceptance of the system in this design. Professionals may need to update the answers they specify for the previous questions either by going backward or forward. And, the combo box named “Kaydedilmiş olan soru seçimi“ is used for this purpose to return a specific question. Professionals are able to turn back to any previous question by clicking on that question in this combo box. New conditions may occur and updates are done in the text version of reports automatically.

**Oesophagus**  
 There isn't narrowness without a clear expansion in oesophagus during the transition of the contrast substance. The mucosal topography is not normal. The topography which is not normal in oesophagus is in the shape of reticular mucosal pattern.

(a)

**Oesophagus**  
 There isn't narrowness without a clear expansion in oesophagus during the transition of the contrast substance. The mucosal topography is not normal. The topography which is not normal in oesophagus is in the shape of reticular mucosal pattern.

(b)

**Oesophagus**  
 There is narrowness without a clear expansion in oesophagus during the transition of the contrast substance. The section in which there isn't a clear expansion during the transition of the contrast substance is proximal 1/3 oesophagus. The length of the narrow segment is 2 cm. The settlement of the narrow segment is symmetrical. The narrow oesophagus segment is cm.

(c)

Figure 4.17: Inline data entry in free-text format: (a) Initial state, abnormal values are highlighted in red, and the field yet to be entered has a gray background. (b) When the user clicks on the link inline editing is activated. (c) The new value “There is” triggers another set of data entries. As the user changes the values of variables, the contents of the report are also rearranged automatically according to predefined trigger conditions.

notifications/rule-based diagnostic suggestions hold. This effectively enables the user to focus on problematic parts and record them in more detail while eliminating other parts to save time, thus avoiding inefficiency and cognitive overload. Moreover, data entries having abnormal values are highlighted in red to call attention to abnormal conditions and the data entries yet to be entered have a gray background. In this way, generating a medical report is supported by some clues. To summarize, SISDS performs with a good interface in which a dynamic dialog between users and the computer is set as a master leading a professional or even an apprentice through a task. The report generation screen, which could be activated by clicking the first box at the right of the patient as listed in Figure 4.12, for a patient as a whole is presented in Figure 4.18. Patient information together with clinical information, which is specified by clinicians during the ordering process, are placed above the report generation section to inform the laboratory professionals. Report is generated according to the features of the SISDS methodology. Free-text information could be inserted into the *report details* section without restricting professionals. At the below, diagnosing process is operated either by inserting at least one diagnosis (up to four ICD-10 coding system arranged in four groups as displayed in Figure 4.19 that is activated after clicking the select button in Figure 4.18) or applying diagnosing decision support systems with the buttons as specified “ apply diagnosing support”, “expert opinion” or “apply DSS specific to a diagnosis”, functions of these sections are detailed in next chapter. Laboratory professional or clinicians are able to add any kind of patient files, images, slices of any film, etc. into patients’ files as displayed in Figure 4.20 , which could be activated by clicking the fourth box, at the right of the patient as listed in Figure 4.12.

In this section, we try to point out how medical reporting benefited from structured and interactive reporting. Rules defined in structured design are triggered by an evaluation of answers recorded for specific sections with interactivity. Here, necessary symptom- or problem-driven sections, which are defined by some privileged experts, are answered. Defined sections are unambiguous sections which lead professionals through examination. The answers may be structured (medial, lateral, superior, inferior) as well as they may be ordinal or quantitative (unit value, percentage, etc.). These sections encourage short or single word answers. According to some studies about visual cognition, under normal viewing conditions only a minor part of the environment is encoded in detail (Noë, Pessoa, & Thompson, 2000): even though the factors that determine which features of a scene are encoded remain unknown, it seems likely that attention plays a major role. Sometimes laboratory professionals could not see other pertinent details while concentrating on a specific subject (lesion, etc.).



## View Record

Patient ID: 3000243545

Patient: I. O.

Birth Date: 01/01/1950

Age: 54

Gender: Male

Date: 27/03/2003

Type: GH

Pre-diagnosis:

Clinic Information: Klinik Tanısı Yok

Description:

Report:

Text

English

**Esophagus (Özafagus)**

The position of the patient is **prone oblique**. The contrast media used in oral way is **barium**. **There isn't** leakage of contrast media out of the lumen. The transition of the contrast media from the esophagus to stomach is **delayed transition**. The feature of the peristalsis wave during the transition of the contrast media is **primary**. **There is** narrowness without a clear expansion in the esophagus during the transition of the contrast media. The section in which there isn't a clear expansion during the transition of the contrast media is **distal 1/3 esophagus**. The length of the narrow segment is **2 cm**. **There is** a filling defect in the esophagus. The number of the filling defects is **1**. The level of the first filling defect is **distal 1/3 esophagus**. The first filling defect is in the shape of **2**. The size of the first filling defect is **2 cm**. **There isn't** ulcerated lesion in the mucosa of the esophagus. **There isn't** an outpouching in the esophagus. **There isn't** significant abnormal dilatation in esophagus during the transition of contrast media. **There isn't** a gastro-esophagus reflux. **There isn't** hernia in the distal esophagus. **There isn't** a gastro-esophagus reflux.

ÖZAFAGUS PASAJ GRAFİSİ: Özafagusun distal 1/3 luk segmentinde konsantrik ve kenarları düzensiz, dar segment izlenmiştir. Darabunç bölümde pasaj geçilmeli olarak değerlendirilmiştir.

Dr. Turan IIICA

Report Detail:

Z13.9 Select  
C15.5 Select  
T28.6 Select  
Select

Diagnosis:

Close report.

Save

Apply Diagnosing Support

Expert Opinion

Tamı seç

Apply DSS specific to a diagnosis

Figure 4.18: Main Report Generation Page.

K00-K93: Sindirim sisteminin hastalıkları
K20-K31: Özefagus mide ve duodenum hastalıkları
K22: Özefagusun diğer hastalıkları
K22.4: Özefagus hareket bozukluğu

Seç

Özefagus hareket

K22.4: Özefagus hareket bozukluğu

Seç

Figure 4.19: Screen to add diagnosis for the generated medical reports in ICD-10 coding system that is arranged in four groups

## Add File

Selected files will be added to the record of N. A.. (Flash 10 yüklü)

[Browse](#) |  Images only | [Clear](#) | [Upload](#)

**General Progress**  
 0%

**File Progress**  
 0%

Click [here](#) to view the report page after uploading the files.

Figure 4.20: Screen of adding any kind of patient files, images, slices of any film, etc. into patients' files , which could be activated by clicking the fourth box, at the right of the patient: more than one file could be uploaded into the patient file. General progress shows the progress of all attached documents where file progress shows the progress of attached files one by one while they are being uploaded into the DB of the system.

**Oesophagus**  
 There is an extravasating of contrast substance out of the lumen. The section of the extravasating is procsimal 1/3 oesophagus. There is narrowness without a clear expansion in oesophagus during the transition of the contrast substance. The section in which there isn't a clear expansion during the transition of the contrast substance is procsimal 1/3 oesophagus. The length of the narrow segment is 2 cm. The settlement of the narrow segment is symmetrical. The narrow oesophagus segment is regular.

(a)

**Oesophagus**

1. Is there an extravasating of contrast substance out of the lumen? = There is.
  1. Which section is the section of the extravasating? = procsimal 1/3 oesophagus.
2. Is there any narrowness without a clear expansion in oesophagus during the transition of the contrast substance? = There is.
  1. In which section there isn't a clear expansion during the transition of the contrast substance? = procsimal 1/3 oesophagus.
    1. What is the length of the narrow segment? = 2 cm.
      1. How is the settlement of the narrow segment? = symmetrical.
        1. How is the narrow oesophagus segment? = regular.

(b)

Figure 4.21: Two different views of the same report: SISDS enables *transparently* collecting structured and *well-formed* data while the health professionals edit the corresponding medical report in a *natural free-text like* style as well as enumerated style: (a) Free-text, and (b) enumerated list.

This phenomenon might be called “change blindness” or “lesion blindness”. In the present study, proper interpretation of images or patients is formulated and attention is provided by guiding professionals through necessary details with predefined sections in great concentration to prevent “change blindness” or “lesion blindness”. Moreover, in order to prevent this, in our implementation the presentation layer is enriched with visual clues. Data fields having abnormal values or yet to be entered are automatically highlighted in different ways to warn the user and draw his attention to those sections of the report (Figure 4.17). These visual clues are handled by options/values selected by users automatically without any update in the formal definitions of reports. We also enabled the user to temporarily hide data entries that are not directly related with a selected data entry (i.e. show only selected data entry together with its descendants and those that are involved in the activation of this data entry). The feedback that we received from initial deployment of the system suggests that users find both features effective and useful (see next chapter).

Besides free-text like data entry, by taking advantage of the separation of data from its representation the prototype also supports data entry in the form of a nested enumerated

## Report

**Patient ID:** 002  
**Patient:** H. A.  
**Age:** 49  
**Gender:** Female  
**Date:** 14/07/2009  
**Type:** G.H

**Pre-diagnosis:**

**Clinic**

**Information:**

**Description:**

**Report: Esophagus (Özafagus)**

The position of the patient is prone oblique. The contrast media used in oral way is contrast media dissolving in water. There isn't leakage of contrast media out of the lumen. The transition of the contrast media from the esophagus to stomach is as normal without delay. The feature of the peristalsis wave during the transition of the contrast media is **tertiary**. The section in which peristalsis waves are observed is **1/3 esophagus**. **There is** narrowness without a clear expansion in the esophagus during the transition of the contrast media. The section in which there isn't a clear expansion during the transition of the contrast media is **proximal 1/3 esophagus**. The length of the narrow segment is **2 cm**. The site of the narrow segment is symmetrical. The narrow esophagus segment is regular. There isn't a filling defect in the esophagus. **There is** ulcerated lesion in the mucosa of the esophagus. The number of the ulcerated lesions is **1**. The size of the first ulcerated lesion is **2.5 cm**. The shape of the first ulcerated lesion is **small superficial ulcers**. There isn't an outpouching in the esophagus. **There is** significant abnormal dilatation in esophagus during the transition of contrast media. The significant abnormal dilatation in esophagus is **proximal 1/3 esophagus**. There isn't surgical operation in the esophagus. There isn't hernia in the distal esophagus. There isn't a gastro-esophagus reflux.

**Report Detail:**

**Diagnosis:** K22.4 K44.9 K21.9

### 002.rar

Figure 4.22: An example of free-text view form for generated reports: abnormal values are notified to attract the attention of clinicians to these section.

list (Figure 4.21) and additional formats can be added with ease. These formats are just different representations of the same data, albeit with different cognitive properties, and it is possible to switch from one to another online during editing. Even though the first one is more natural, the enumerated list may be more convenient and preferable in certain cases – especially when the health care professional is interested in seeing the hierarchical structure of the report which is hidden in the first one. Free text could also be appended to the report (the section of report details in Figure 4.18 is reserved for this reason) in the SISDS method if needed to avoid confining professionals in predefined rule set .

The report viewing and writing report section screen, which could be activated by clicking the second box to view as free-text and by clicking the third box to view as structured nested hierarchical, at the right of the patient as listed in Figure 4.12. These screens are especially designed for clinicians who order the reports for their patients. An example of free-text view form of generated reports is displayed in Figure 4.22. An example of structured nested hierarchical view form of generated reports is displayed in Figure 4.23.

The present medical reporting method brings a new understanding for writing or displaying generated reports from the point of view of their readers. It is possible for physicians to see reports generated by laboratory professionals either in free-text form or in a structured and in a hierarchy. Several kinds of generated reports of an esophagus examination

**Patient ID:** 002  
**Patient:** H. A.  
**Age:** 49  
**Gender:** Female  
**Date:** 14/07/2009  
**Type:** G.H  
**Pre-diagnosis:**  
**Clinic**  
**Information:**  
**Description:**  
**Report: Esophagus (Özafagus)**

1. How is the position of the patient? = prone oblique.
2. What is the contrast media used in oral way? = contrast media dissolving in water.
3. Is there leakage of contrast media out of the lumen? = There isn't.
4. How is the transition of the contrast media from the esophagus to stomach? = as normal without delay.
5. What is the feature of the peristalsis wave during the transition of the contrast media? = **tertiary**.
  1. In which section peristalsis waves are observed? = **1/3 esophagus**.
6. Is there any narrowness without a clear expansion in the esophagus during the transition of the contrast media? = **There is**.
  1. In which section there isn't a clear expansion during the transition of the contrast media? = **proximal 1/3 esophagus**.
    1. What is the length of the narrow segment? = **2 cm**.
      1. what is the site of the narrow segment? = symmetrical.
        1. How is the narrow esophagus segment? = regular.
7. Is there a filling defect in the esophagus? = There isn't.
8. Is there ulcerated lesion in the mucosa of the esophagus? = **There is**.
  1. How many ulcerated lesions are there? = **1**.
    1. What is the size of the first ulcerated lesion? = **2.5 cm**.
      1. what is the shape of the first ulcerated lesion? = **small superficial ulcers**.
9. Is there an outpouching in the esophagus? = There isn't.
10. Is there any significant abnormal dilatation in esophagus during the transition of contrast media? = **There is**.
  1. Where is the significant abnormal dilatation in esophagus? = **proximal 1/3 esophagus**.
11. Is there any surgical operation in the esophagus? = There isn't.
12. Is there hernia in the distal esophagus? = There isn't.
13. Is there a gastro-esophagus reflux? = There isn't.

**Report Detail:**

**Diagnosis:** K22.4 K44.9 K21.9

---

Figure 4.23: An example of structured nested and hierarchical view form of generated reports: abnormal values are notified to attract the attention of clinicians to these section.

are depicted in following chapter. Physicians are guided through reports with some clues such as paying their attention to abnormal values that are automatically color coded in red to call attention to abnormal conditions and to reduce errors. Decision-support techniques are specifically identified by the Institute of Medicine's (IOM) as key elements in efforts to improve patient safety. One of the most widely used decision support applications is "results reporting of normal and abnormal values (Ash, Berg, & Coiera, 2004)". In this manner, SISDS is a decision supporting system. What's more, clinicians may consult other colleagues in their native language by transforming the report into other languages instantly as is. The reporting styles in SISDS present an appropriate format and content to allow information display that supports both efficient patient care and optimal clinician workflow. In other words, report structure and content are ultimately tailored to suit the needs of clinicians. When medical report formats are examined in several hospital information systems (HIS) or laboratory systems, it is possible to see many different reporting windows to generate medical reports. Our method provides an easy and effective solution to medical professionals to generate reports in high quality with standardized windows in which structured and interactive design is merged together.

The screen of *settings* in Figure 4.2 is displayed in Figure 4.24: users could change their password as well as their language settings. All screen information together with report format information is transformed into the specified language in the settings as mentioned in the previous chapter. Users are also able to share their patients' information with their colleagues by specifying their authorization either as view just to permit them to see or edit to allow them to see and update. Authorized patient information could be listed in patient list after the user who allows his/her patient to be shared is selected in the filter screen in Figure 4.13. Thus, consulting to other experts is made possible.

Users are expected to evaluate the most common approaches together with SISDS in a questionnaire. The questionnaire screen (Figure 4.24) is displayed after clicking the task of survey in Figure 4.2. The details about the questionnaire are presented in next Chapter 5.

The tasks of help and document in Figure 4.2 include documents about how to use the application and the features of the SISDS methodology together with information about other approaches.

We would like to emphasize that SISDS allows users to enter free-text data as needed apart from predefined hierarchical structure to avoid any strict customization of medical reporting as advised by Siström (Siström, 2005). Each case may sure need a special explanation. All implemented codes together with established DDSS and the Database on which

If you are not Uğur BOZLAR please click [here](#). [Exit](#)

[Record List](#) | [Settings](#) | [Survey](#) | [Help](#) | [Documents](#)

## Settings

**Your name:** Uğur BOZLAR

**Institution:** GATA

**Title:** Assoc. Prof. ▾

**Language:** English ▾

**Country:** Turkey ▾

**Current Password:**

**New Password:**

**(Again)**

## User Access

<input type="button" value="View"/>	Assoc. Prof. Administrator (Hacettepe, Turkey)	- ▾	Prof. Barış Diren (Medicana
<input type="button" value="Edit"/>	nal Ankara Hastanesi, Turkey)	- ▾	Doctor dr1 (Onkoloji Hastanesi, Turkey) - ▾
	10 (Onkoloji Hastanesi, Turkey)	- ▾	Doctor dr11 (Onkoloji Hastanesi, Turkey) - ▾
	Doctor dr2 (Onkoloji Hastanesi, Turkey)	- ▾	Doctor dr3 (Onkoloji Hastanesi, Turkey) - ▾
	Doctor dr4 (Onkoloji Hastanesi, Turkey)	- ▾	Doctor dr5 (Onkoloji Hastanesi, Turkey) - ▾
	Doctor dr6 (Onkoloji Hastanesi, Turkey)	- ▾	Doctor dr7 (Onkoloji Hastanesi, Turkey) - ▾
	Doctor dr8 (Onkoloji Hastanesi, Turkey)	- ▾	Doctor dr9 (Onkoloji Hastanesi, Turkey) - ▾
	Prof. Emin Alp Niron (Başkent Üniversitesi, Turkey)	- ▾	Prof. Ferhun Balkancı (Hacettepe Tıp
	Fakültesi, Turkey) - ▾		Assoc. Prof. Kemal ARDA (Yenimahalle Onkoloji Hastanesi, Turkey)
<input type="button" value="Edit"/>	Doctor Veysel AKGÜN (GATA, Turkey)		

Figure 4.24: Screen of user settings: users could change their password as well as their language settings. Users are also able to share their patients' information with their colleagues by specifying their authorization either as view just to permit them to see or edit to allow them to see and update.

## Methods

**HANDWRITING** [HANDWRITING](#)

**TOS** [TRANSCRIPTIONIST-ORIENTED SYSTEMS \(Recorded speech files to be dictated later by medical transcriptionists\)](#)

**RTTOS** [REAL TIME TRANSCRIPTIONIST-ORIENTED SYSTEMS \(Recording in real-time using medical transcriptionists\)](#)

**TELEPHONE** [TELEPHONE ACCESS \(automated voice recording system\)](#)

**DBSR** [DICTATION BY SPEECH RECOGNITION](#)

**ASDCIAS** [ALL STRUCTURED DATA COLLECTED IN A SCREEN](#)

**SISDS** [SISDS \(A Structured, Interactive, Standardized, Decision Supporting\)](#)

## Questions

1. Do you agree that a targeted and desired quality of care can be delivered through uniform work practices with the current model?

<b>HANDWRITING</b>	Totally Disagree	▼
<b>TOS</b>	Disagree	▼
<b>RTTOS</b>	Disagree	▼
<b>TELEPHONE</b>	Disagree	▼
<b>DBSR</b>	Disagree	▼
<b>ASDCIAS</b>	Agree	▼
<b>SISDS</b>	Agree	▼

2. Do you agree that users are guided thoroughly through details to analyse correctly with the current model?

<b>HANDWRITING</b>	Disagree	▼
<b>TOS</b>	Disagree	▼
<b>RTTOS</b>	Disagree	▼
<b>TELEPHONE</b>	Disagree	▼
<b>DBSR</b>	Disagree	▼
<b>ASDCIAS</b>	Agree	▼
<b>SISDS</b>	Totally Agree	▼

3. Do you agree that the current model provides an educational/training support.

<b>HANDWRITING</b>	Totally Disagree	▼
<b>TOS</b>	Totally Disagree	▼
<b>RTTOS</b>	Totally Disagree	▼
<b>TELEPHONE</b>	Totally Disagree	▼
<b>DBSR</b>	Totally Disagree	▼
<b>ASDCIAS</b>	Agree	▼
<b>SISDS</b>	Totally Agree	▼

Figure 4.25: Screen of the questionnaire to evaluate the methods.



implemented codes run are in the DVD attached to this thesis and the prototype could be installed at any computer as well to test <sup>7</sup>.

---

<sup>7</sup>A demo version of the prototype is available online at the following address for hands-on experience:  
<http://www.gata.edu.tr/mebs/sisds>

# CHAPTER 5

## EXPERIMENTAL RESULTS: EVALUATION AND TESTING OF THE SISDS METHODOLOGY

In this section, the performance and the viability of the SISDS methodology has been evaluated and tested based on three criteria:

1. the acceptability of the methodology by the users who generated medical reports with the proposed system,
2. whether the stored data can be used effectively for designing DDSS without tedious data preprocessing and data preparation steps, and
3. the performance of the proposed approach compared to the existing approaches to test its's real world performance.

High quality data are needed to create healthcare information standards for structured information capture. Creating an agreed-upon standardized minimum data set seems necessary for any data collection effort. A minimum data set refers to a core set of data elements required for each case or record in a database (CIHI, 2005). The development of interactive systems depends on the existence of information based on clear specific domain terminologies, functional hierarchies and decision rules. We have developed an algorithm that provides an architectural design to generate medical report formats by privileged users to address such concerns. As a real-world testbed for the SISDS methodology, we chose the field of radiology and a sample esophagus report structure was constructed by radiology experts from several hospitals using the web-based prototype. The esophagus report structure was prepared by consulting 12 radiologists working in six different hospitals, five of whom

**Esophagus (Özafagus)**  
Hastanın pozisyonu **erect, sol lateral**dir. Oral yoldan kullanılan kontrast madde **baryum maddesi**dir. Kontrast maddenin lümen dışına kaçı **yoktur**. Kontrast maddenin özofagustan mideye geçişi **beklemeden normal hızla olmuştur**. Kontrast madde geçişi sırasında görülen peristaltik dalganın özelliği **primer**dir. Kontrast madde geçisi sırasında özofagusta belirgin genişleme göstermeyen, dar (13 mm den daha az) bölüm **yok**. Özofagusta mukazal rölüf **normal**dir. Özofagusta dolum defekti **yoktur**. Özofagus mukozasında ülsere lezyon **yoktur**. Özofagusta dolum fazlalığı **yoktur**. Kontrast maddenin geçisi sırasında özofagusta normal dışı belirgin genişleme **yoktur**. Özofagusta geçirilmiş cerrahi müdahale **yoktur**. Distal özofagusta herni **yoktur**. Gastroözafageal reflü **yoktur**.

(a)

**Esophagus (Özafagus)**  
The position of the patient is **erect, left lateral**. The contrast media used in oral way is **barium**. **There isn't** leakage of contrast media out of the lumen. The transition of the contrast media from the esophagus to stomach is **as normal without delay**. The feature of the peristalsis wave during the transition of the contrast media is **primary**. **There isn't** narrowness without a clear expansion in the esophagus during the transition of the contrast media. The mucosal relief of the esophagus is **normal**. **There isn't** a filling defect in the esophagus. **There isn't** ulcerated lesion in the mucosa of the esophagus. **There isn't** an outpouching in the esophagus. **There isn't** significant abnormal dilatation in esophagus during the transition of contrast media. **There isn't** surgical operation in the esophagus. **There isn't** hernia in the distal esophagus. **There isn't** a gastro-esophagus reflux.

(b)

Figure 5.1: Initial skeleton of the esophagus report with normal values in free-text form: (a) in Turkish, and (b) in English. The values in blue color indicate normal values. The values on gray ground indicate that they are proposed by the system and yet to be entered by the user.

Esophagus (Özafagus)	
1.	Hastanın pozisyonu nasıldır? <a href="#">yatarak prone oblik</a> dir.
2.	Oral yoldan kullanılan kontrast madde nedir? = <a href="#">baryum maddesidir</a> .
3.	Kontrast maddenin lümen dışına kaçıışı var mıdır? = <a href="#">yoktur</a>
4.	Kontrast maddenin özofagustan mideye geçişi nasıldır? = <a href="#">beklemeden normal hızla olmuştur</a> .
5.	Kontrast madde geçişi sırasında görülen peristaltik dalganın özelliği nedir? = <a href="#">primer</a> dir.
6.	Kontrast madde geçişi sırasında özofagusta belirgin genişleme göstermeyen, dar (13 mm den daha az) bölüm var mı? = <a href="#">yok</a> .
1.	Özofagusta mukozal rölyef nasıldır? = <a href="#">normal</a> dir.
7.	Özofagusta dolum defekti var mıdır? = <a href="#">yoktur</a> .
8.	Özofagus mukozasında ülsere lezyon var mıdır? = <a href="#">yoktur</a> .
9.	Özofagusta dolum fazlalığı var mıdır? = <a href="#">yoktur</a> .
10.	Kontrast maddenin geçişi sırasında özofagusta normal dışı belirgin genişleme var mı? = <a href="#">yoktur</a>
11.	Özofagusta geçirilmiş cerrahi müdahale var mıdır? = <a href="#">yoktur</a> .
12.	Distal özofagusta herni var mıdır? = <a href="#">yoktur</a> .
13.	Gastroözofageal reflü var mıdır? = <a href="#">yoktur</a> .

(a)

Esophagus (Özafagus)	
1.	How is the position of the patient? = <a href="#">prone oblique</a> .
2.	What is the contrast media used in oral way? = <a href="#">barium</a> .
3.	Is there leakage of contrast media out of the lumen? = <a href="#">There isn't</a> .
4.	How is the transition of the contrast media from the esophagus to stomach? = <a href="#">as normal without delay</a> .
5.	What is the feature of the peristalsis wave during the transition of the contrast media? = <a href="#">primary</a> .
6.	Is there any narrowness without a clear expansion in the esophagus during the transition of the contrast media? = <a href="#">There isn't</a> .
1.	How is the mucosal relief of the esophagus? = <a href="#">normal</a> .
7.	Is there a filling defect in the esophagus? = <a href="#">There isn't</a> .
8.	Is there ulcerated lesion in the mucosa of the esophagus? = <a href="#">There isn't</a> .
9.	Is there an outpouching in the esophagus? = <a href="#">There isn't</a> .
10.	Is there any significant abnormal dilatation in esophagus during the transition of contrast media? = <a href="#">There isn't</a> .
11.	Is there any surgical operation in the esophagus? = <a href="#">There isn't</a> .
12.	Is there hernia in the distal esophagus? = <a href="#">There isn't</a> .
13.	Is there a gastro-esophagus reflux? = <a href="#">There isn't</a> .

(b)

Figure 5.2: Initial skeleton of the esophagus report with normal values as structured question/answer view: (a) in Turkish, and (b) in English. The values in blue color indicate normal values. The indentation designates the hierarchy among data entries: the data entry of “Özofagusta mukozal rölyef nasıldır= normaldir” belongs to the data entry, which is numbered as 6, of “Kontrast madde geçişi sırasında özofagusta belirgin genişleme göstermeyen, dar (13 mm den daha az) bölüm var mı? = yok”.

are the head of their departments. Despite the fact that the essential part of the report is based on Weissleder's book (Weissleder, Jones, Wittenberg, Harisinghani, & Harisinghani, 2003) that is a textbook on radiology, the experts had different insights about the details of the report and hence reaching a consensus turned out to be a non-trivial task. The report consists of 13 main and 59 auxiliary data entries in a hierarchy having a maximum depth of 4. Each main data entry has a single nominal variable, and the report contains a total of 72 variables (53 nominal and 19 numerical) making it a fine example of a moderate sized medical report. The entire structure of the esophagus report including all data entries and triggered-based conditions can be found in Appendix A. In the report, the main data groups are numbered from 1 to 13 in which main data entries are displayed towards the numbers first in Turkish language format and second below it English language format is displayed. Parameter definitions are defined in between words as to constitute complete meaningful sentences. The initial skeleton of the esophagus report which is displayed in preferred language for professionals to generate their reports is depicted in Figure 5.1 as free-text style, and in Figure 5.2 as structured tabular nested list such as structured question/answer view. It is worth noting that it is unrealistic to expect a professionals to fill 72 fields in an application window as displayed in Figure 2.4. The interactivity via minimum structured data set in a standardized window is our proposed solution to avoid inefficiency, cognitive overload and medical errors. The user should just update some of the values of patient findings that are different from the data entries the system proposes as initial values. The report is rearranged as the user interacts with the report by entering values of a patient findings in data fields. The number of data entries which are needed to be filled by professionals may increase dynamically in accordance with problematic parts that patients have. An example of the rearranged esophagus report with most of the updated abnormal data entries is depicted in Figure 5.3 as free-text style, and in Figure 5.4 and in Figure 5.5 as structured tabular nested list such as structured question/answer view, note that it is not common to observe all these abnormalities for a patient in a case. Users may prefer any styles and interchange them online instantly without losing their entered values. After filling in the report, at least one diagnosis (up to 4) must be entered according to the ICD-10 coding scheme. The International Statistical Classification of Diseases and Related Health Problems 10th Revision (ICD-10) is a coding of over 155000 diseases and signs, symptoms, abnormal findings, complaints, social circumstances and external causes of injury or diseases, as classified by the World Health Organization (WHO) (Wikipedia, 2005c). The adoption of ICD-10 would help in capturing of more specific clinical information on disease severity, including compli-

cations, co-morbidities and risk factors (NCVHS, 2005). It will provide greater specificity for ascertaining severity of disease for risk/severity adjustment of health outcomes and will enable international comparisons of quality of care and the sharing of best practices among nations that have adopted ICD-10 (NCVHS, 2005).

System operation begins with the professional entering his or her authorized username and password to connect to the system. A list of patients, which was loaded from previous retrospective data <sup>1</sup> in several hospital information systems (HIS), is displayed if these patients are assigned to the professional: header information consists of the date (of admission), (admission) number, patient('s name), sex, age, user (name who lastly updated the record), (highlighted name of image) files, # of images (as the number of slices), (the kind of the) report, (the status of report whether it is) closed and (the status of whether it is) deleted as presented in Figure 4.12. This list of patients can be filtered by means of a filter section located above the patient list as exemplified in Figure 4.13. In a period of six months, health care professionals from the radiology departments of six different hospitals <sup>2</sup> retrospectively entered real patient esophagus reports using the web-based prototype. All personal information relating to patients (date of birth, name, surname etc.) was loaded into the database previously as to imitate these information are drawn from HIS. Radiologists were just concerned about their medical reporting process while examining images or patients to generate reports and they weren't expected to enter personal information of patients as in the real working conditions. Medical reports could be generated by clicking the first box which is located at the right side of patient information listed in Figure 4.12. Professionals generated esophagus reports for their assigned patients by the help of the web-based prototype. The resulting data set contains 1240 instances spanning a period of seven years from 2003 to 2009. The age/sex distribution of population is 47.87% male, 52.13% female with a minimum age of 1 and a maximum age of 87 (see Figure 5.6(a)). The professionals who generated medical reports answered the questions in a questionnaire that is placed on their screens. Some information about the steps of the preparation of the questionnaire and evaluation of the viability of the system by field experts with the questionnaire are presented in the following two sections.

---

<sup>1</sup>New admission of patients are available in the system: each user may admit new patients.

<sup>2</sup>These hospitals are Hacettepe Medical University, Medicana International Training and Research Hospital, Gülhane Military Medical Academy, Başkent University, Turkish Oncology Training and Research Hospital and Yüksek İhtisas Training and Research Hospital.

### Esophagus (Özafagus)

Hastanın pozisyonu **semierect**dir. Oral yoldan kullanılan kontrast madde **suda erir kontrast maddedir**. Kontrast maddenin lümen dışına kaçışı **vardır**. Kaçağın olduğu özafagus bölgesi **orta 1/3 özafagus**dur. Kontrast maddenin özafagustan mideye geçişi **beklenerek belirli seviye oluşuktan sonra olmuştur**. Görülen seviye **1/3 alt özafagusta**tadır. Kontrast madde geçişi sırasında görülen peristaltik dalgalının özelliği **primer sekunder tersiyel**dir. Tersiyer peristaltik dalgalının saptandığı özafagus seviyesi **distal 1/3 özafagusta**dır. Kontrast madde geçişi sırasında özafagusta belirgin genişleme göstermeyen, dar (13 mm den daha az) bölüm **var**. Özafagusun belirgin genişleme olmayan bölgesinin seviyesi **tüm özafagus**dur. Dar segmentin yerleşimi **asimetrik**tir. Dar özafagus segmenti **düzensiz**dir. Özafagusta dolum defekti **vardır**. Dolum defekti **multiple** tanedir. En küçük dolum defektinin seviyesi **orta 1/3 özafagustur**. En küçük dolum defektinin düzensiz polipoid saphı şeklindedir. En küçük dolum defektinin boyutu **2 cm** dir. En büyük dolum defektinin seviyesi **tüm özafagustur**. En büyük dolum defektin yılanvar kıvrımlı dolum şeklindedir. En büyük dolum defektinin boyutu **3 cm** dir. Özafagus mukozasında ülsere lezyon **vardır**. Ülsere lezyon **multiple** tanedir. En küçük ülsere lezyonun boyutu **1 cm** dir. En küçük ülsere lezyonun **beş elmas (diamond shape)** şeklindedir. En büyük ülsere lezyonun boyutu **2 cm** cm dir. En büyük ülsere lezyonun **düzensiz sınırlı** şeklindedir. Özafagusta dolum fazlalığı **vardır**. Dolum fazlalığı **2** tanedir. İlk dolum fazlalığı seviyesi **orta 1/3 özafagus**tur. İlk dolum fazlalığı **lateraldedir**. İlk dolum fazlalığının boyutu **1.5 cm** dir. İkinci dolum fazlalığı seviyesi **distal 1/3 özafagus**tur. İkinci dolum fazlalığı **arkadadır**. İkinci dolum fazlalığının boyutu **2 cm** dir. Kontrast maddenin geçişi sırasında özafagusta normal dışı belirgin genişleme **vardır**. Normal dışı belirgin genişleme **orta 1/3 özafagus** tadır. Özafagusta geçirilmiş cerrahi müdahale **vardır**. Anastomoz hattı genişliği **darır**. Distal özafagusta herni **vardır**. Herni **paraözofajial** tipindedir. Gastroözofajiel reflü **vardır**.

(a)

### Esophagus (Özafagus)

The position of the patient is **semierect**. The contrast media used in oral way is **contrast media dissolving in water**. **There is** leakage of contrast media out of the lumen. The section of the extravasating is **middle 1/3 esophagus**. The transition of the contrast media from the esophagus to stomach is **happens after a level occurred and with delay**. The site of the level is **1/3 lower esophagus**. The feature of the peristaltic wave during the transition of the contrast media is **primer, secondary, tertiary**. The section in which peristaltic waves are observed is **distal 1/3 esophagus**. **There is** narrowness without a clear expansion in the esophagus during the transition of the contrast media. The section in which there isn't a clear expansion during the transition of the contrast media is **whole esophagus**. The length of the narrow segment is **3 cm**. The site of the narrow segment is **asymmetrical**. The narrow esophagus segment is **irregular**. **There is** a filling defect in the esophagus. The number of the filling defects is **multiple**. The level of the smallest filling defect is **middle 1/3 esophagus**. The smallest filling defect is in the shape of **irregular polypoid pedunculated**. The size of the smallest filling defect is **2 cm**. The level of the largest filling defect is **whole esophagus**. The largest filling defect is in the shape of **snake-like curly filled**. The size of the largest filling defect is **3 cm**. **There is** ulcerated lesion in the mucosa of the esophagus. The number of the ulcerated lesions is **multiple**. The size of the smallest ulcerated lesion is **1 cm**. The shape of the first ulcerated lesion is **giant diamond ulcer**. The size of the largest ulcerated lesion is **2 cm**. The shape of the largest ulcerated lesion is **irregular restrictive**. **There is** an outpouching in the esophagus. The number of outpouchings is **2**. The level of the first outpouching is **middle 1/3 esophagus**. The first outpouching is in **lateral**. The size of the outpouching is **1.5 cm**. The level of the second outpouching is **distal 1/3 esophagus**. The second outpouching is in **back**. The size of the second outpouching is **2 cm**. **There is** significant abnormal dilatation in esophagus during the transition of contrast media. The significant abnormal dilatation in esophagus is **middle 1/3 esophagus**. **There is** surgical operation in the esophagus. The wideness of anastomoses line is **narrow**. **There is** hernia in the distal esophagus. The type of esophagus is **paraesophag**. **There is** a gastro-esophagus reflux.

(b)

Figure 5.3: Esophagus report with most of the triggered report-wide trigger conditions: (a) in Turkish, (b) in English. The values in blue color indicate normal values while the values on red ground indicate abnormal values.

## Esophagus (Özafagus)

1. Hastanın pozisyonu nasıldır? **semierekt**dir.
2. Oral yoldan kullanılan kontrast madde nedir? = **suda erir kontrast madde**dir.
3. Kontrast maddenin lümen dışına kaçıışı var mıdır? = **vardır**.
  1. Kaçağın olduğu özafagus bölgesi neresidir? = **orta 1/3 özafagus** tur.
4. Kontrast maddenin özofagustan mideye geçişi nasıldır? = **bekleyerek belirli seviye oluştuktan sonra olmuştur**.
  1. Görülen seviye nasıldır? = **1/3 alt özafagusta** dir.
5. Kontrast madde geçişi sırasında görülen peristaltik dalganın özelliği nedir? = **primer seconder tersiyer** dir.
  1. Tersiyer peristaltik dalgaların saptandığı özafagus seviyesi nedir? = **distal 1/3 özafagusta** dir.
6. Kontrast madde geçişi sırasında özafagusta belirgin genişleme göstermeyen, dar (13 mm den daha az) bölüm var mı? = **var**.
  1. Özafagusun belirgin genişleme olmayan bölgesi hangi seviyededir? = **tüm özafagus** tur.
    1. Dar segment uzunluğu ne kadardır? = **3 cm** dir.
    1. Dar segmentin yerleşimi nasıldır? = **asimetrik** tir.
      1. Dar özafagus segmenti nasıldır? = **düzensiz** dir.
7. Özafagusta dolum defekti var mıdır? = **vardır**.
  1. Dolum defekti kaç tanedir? = **multiple** tanedir.
    1. En küçük dolum defekti hangi seviyededir? = **orta 1/3 özafagusta** tur.
      1. En küçük dolum defekti nasıldır? = **düzensiz polipoid saplı** şeklindedir.
        1. En küçük dolum defektinin boyutu ne kadardır? = **2 cm** dir.
      1. En büyük dolum defekti hangi seviyededir? = **tüm özafagusta** tur.
        1. En büyük dolum defekti nasıldır? = **yılanvari kıvrıntılı dolum** şeklindedir.
          1. En büyük dolum defektinin boyutu ne kadardır? = **3 cm** dir.
  8. Özafagus mukozasında ülsere lezyon var mıdır? = **vardır**.
    1. Ülsere lezyonun kaç tanedir? = **multiple** tanedir.
      1. En küçük ülsere lezyonun boyutu ne kadardır? = **1 cm** dir.
        1. En küçük ülsere lezyonun şekli nasıldır? = **dev elmas (diamond shape)** şeklindedir.
      1. En büyük ülsere lezyonun boyutu ne kadardır? = **2 cm** dir.
        1. En büyük ülsere lezyonun şekli nasıldır? = **düzensiz sınırlı** şeklindedir.
  9. Özafagusta dolum fazlalığı var mıdır? = **vardır**.
    1. Dolum fazlalığı kaç tanedir? = **2** tanedir.
      1. İlk dolum fazlalığı seviyesi nedir? = **orta 1/3 özafagus** tur.
        1. İlk dolum fazlalığı nerededir? = **lateral**dedir.
          1. İlk dolum fazlalığının boyutu ne kadardır? = **1.5 cm** dir.
        1. İkinci dolum fazlalığı seviyesi nedir? = **distal 1/3 oesophagus** tur.
          1. İkinci dolum fazlalığı nerededir? = **arkadır**.
            1. İkinci dolum fazlalığının boyutu ne kadardır? = **2 cm** dir.
    10. Kontrast maddenin geçişi sırasında özafagusta normal dışı belirgin genişleme var mı? = **vardır**.
      1. Normal dışı belirgin genişleme özafagusun neresindedir? = **orta 1/3 özafagus** tadır.
    11. Özafagusta geçirilmiş cerrahi müdahale var mıdır? = **vardır**.
      1. Anastomoz hattı genişliği nasıldır? = **dar**dır.
    12. Distal özafagusta herni var mıdır? = **vardır**.
      1. Herni hangi tip bir hernidir? = **paraözofajial** tipindedir.
    13. Gastroözofajial reflü var mıdır? = **vardır**.

Figure 5.4: Esophagus report with most of the triggered report-wide trigger conditions as structured tabular nested list such as structured question/answer view in Turkish. The values in blue color indicate normal values while the values on red ground indicate abnormal values. The indentation designates the hierarchy among data entries: The data entry of “Dolum defekti kaç tanedir? =multiple” belongs to the data entry, which is numbered as 7, of “Özafagusta dolum defekti var mıdır? = vardır”.



Esophagus (Özafagus)	
1.	How is the position of the patient? = <u>semierect</u> .
2.	What is the contrast media used in oral way? = <u>contrast media dissolving in water</u> .
3.	Is there leakage of contrast media out of the lumen? = <u>There is</u> .
1.	Which section is the section of the extravasating? = <u>middle 1/3 esophagus</u> .
4.	How is the transition of the contrast media from the esophagus to stomach? = <u>happens after a level occurred and with delay</u> .
1.	What is the site of the level? = <u>whole esophagus</u> .
5.	What is the feature of the peristalsis wave during the transition of the contrast media? = <u>primer secondary tertiary</u> .
1.	In which section peristalsis waves are observed? = <u>distal 1/3 esophagus</u> .
6.	Is there any narrowness without a clear expansion in the esophagus during the transition of the contrast media? = <u>There is</u> .
1.	In which section there isn't a clear expansion during the transition of the contrast media? = <u>whole esophagus</u> .
1.	What is the length of the narrow segment? = <u>3 cm</u> .
1.	What is the site of the narrow segment? = <u>asymmetrical</u> .
1.	How is the narrow esophagus segment? = <u>irregular</u> .
7.	Is there a filling defect in the esophagus? = <u>There is</u> .
1.	What is the number of the filling defects? = <u>multiple</u> .
1.	What is level of smallest filling defect? = <u>middle 1/3 esophagus</u> .
1.	How is the shape of the smallest filling defect? = <u>irregular polipoid pedunculated</u> .
1.	What is the size of the smallest filling defect? = <u>2 cm</u> .
1.	What is level of the largest filling defect? = <u>whole esophagus</u> .
1.	How is the shape of the largest filling defect? = <u>snakelike curly filled</u> .
1.	What is the size of largest the filling defect? = <u>3 cm</u> .
8.	Is there ulcerated lesion in the mucosa of the esophagus? = <u>There is</u> .
1.	How many ulcerated lesions are there? = <u>multiple</u> .
1.	What is the size of the smallest ulcerated lesion? = <u>1 cm</u> .
1.	What is the shape of the smallest ulcerated lesion? = <u>giant diamond ulcer</u> .
1.	What is the size of the largest ulcerated lesion? = <u>2 cm</u> .
1.	What is the shape of the largest ulcerated lesion? = <u>irregular restrictive</u> .
9.	Is there an outpouching in the esophagus? = <u>There is</u> .
1.	How many outpouchings are there? = <u>2</u> .
1.	What is the level of the first outpouching? = <u>middle 1/3 esophagus</u> .
1.	Where is the outpouching filling? = <u>lateral</u> .
1.	What is the size of the first outpouching? = <u>1.5 cm</u> .
1.	What is the level of the second outpouching? = <u>distal 1/3 esophagus</u> .
1.	Where is the second outpouching? = <u>back</u> .
1.	What is the size of the second outpouching? = <u>2 cm</u> .
10.	Is there any significant abnormal dilatation in esophagus during the transition of contrast media? = <u>There is</u> .
1.	Where is the significant abnormal dilatation in esophagus? = <u>middle 1/3 esophagus</u> .
11.	Is there any surgical operation in the esophagus? = <u>There is</u> .
1.	How is the wideness of anastomoses line? = <u>narrow</u> .
12.	Is there hernia in the distal esophagus? = <u>There is</u> .
1.	What is the type of hernia? = <u>paraesophag</u> .
13.	Is there a gastro-esophagus reflux? = <u>There is</u> .

Figure 5.5: Esophagus report with most of the triggered report-wide trigger conditions as structured tabular nested list such as structured question/answer view in English. The values in blue color indicate normal values while the values on red ground indicate abnormal values. The indentation designates the hierarchy among data entries: The data entry of “What is the number of the filling defects? =multiple” belongs to the data entry, which is numbered as 7, of “Is there a filling defect in the esophagus? = There is”.

## 5.1 Preparation of a Questionnaire to Evaluate the SISDS Methodology

Some documents and books about questionnaire design were examined before beginning designing the questionnaire such as “questionnaire design and analysis” (Galloway, 1997) and “questionnaire design (O’Brien, 1997), and the steps of building a questionnaire as defining the objectives of the survey, determining the scope and sampling group, determining the questions in the questionnaire, administering the questionnaire and interpretation of the results were carried out one by one. The questionnaire is aimed to measure the overall performance of the system as well as the specific components of the system including information on the participants. Our questionnaire first aims to measure four main components as *medical issues*, *other general issues*, *learning organization* and *EPSS*. We aimed to measure whether it is regarded as an *electronic performance support system* and *whether it is leading organizations to be a learning organization* with the last two components:

- *medical issues* include “faster response to physician’s clinical orders”, “transcriptionist cost”, “medical errors, patient safety”, “data privacy, confidentiality”, “hygienic working environment”, “prevention of lesion blindness , right diagnosis” and “healthcare professionals’ productivity, patient satisfaction”;
- *other general issues* include “standardization”, “overall cost efficient”, “focus”, “preference, recommendation”, “maintenance/ support cost”, “user orientation” and “overall benefits”;
- *learning organization* includes “achievement of sustainable objectives”, “continues improvement of complex and changing tasks”, “learning of all its members”, “research capability”, “management of knowledge” and “content management and consistent content”;
- *EPSS* includes “quality through uniform work practices”, “quality between inexperienced and experienced”, “advisory system”, “learning/training support, training cost”, “user-friendly, ease of use” and “overall level of performance of all components”.

The selected criteria in the questionnaire were mainly designated both in terms of the four components mentioned above and by taking the advantages and shortcomings of related works mentioned in Chapter 2 into consideration to measure whether the proposed methodology covers the advantages and removes the shortcomings of the related works. Some

criteria such as EPSS and learning organization were put in questionnaire to measure some other aspects of the methodology. These criteria weren't evaluated for previous related work, but they are indispensable to evaluate a system whether it is to be a long term system. For testing the effectiveness and the acceptance of the SISDS in comparison to the existing approaches, questions in the questionnaire were prepared with clear, succinct, and unambiguous close-ended multiple-choice questions that were supplied by the field experts. The questionnaire was prepared by involving field experts and health care professionals in the designing process. Correlated questions, such as the performance and the satisfaction with the system among different groups of users, are prepared to measure the criteria listed in Table 5.1 to reduce the bias or social mask<sup>3</sup>. The questionnaire was examined in a pilot test by some field experts such as statisticians, physicians and laboratory professionals from several hospitals before being put into practice. The questionnaire was updated by means of the feedbacks taken from the experts, one of which from statisticians was to reduce the bias or social mask, another one from medical professionals was to make the questions more understandable for everybody to be unambiguous. The number of questions differs to measure each criterion and range between 3 and 13 for several reasons, one of which is to decrease the social mask. Some of the questions are common to several criteria, and such questions are enlisted independently for each case. The numbers of the questions in the questionnaire to measure the criteria in Table 5.1 are specified in Table B.1 in the Appendix B. For instance, the question numbers of 1, 9, 11, 14, 15, 16, 19, 20, 21, 22, 23, 27, 30 are averaged to measure the "quality of care" whereas the numbers of 3, 4, 5, 6, 7, 11, 14, 27, 30 are averaged to measure "user-productivity (number of reports / time)". As you see the numbers of 11, 14, 27 and 30 are included in the evaluation for both criteria. An EPSS is to enhance the process of medical reporting by improving the poor performance while providing decision supporting and just-in-time learning abilities to users. It enables an unexperienced professional to perform properly at an expert's level with minimal cognitive effort, support and intervention by others by avoiding the inefficiency and the cognitive overload. In this respect, the questions numbered as 2, 3, 6, 7, 8, 13, 14, 15, 20, 21, 22, 27 and 30 are prepared to measure the criterion of EPSS. A learning organization manages the knowledge in the organization very well either by transforming data created in the organization into knowledge or incorporating knowledge created in the environment. Therefore, the questions numbered as 3, 7, 12, 13, 14, 15, 20, 21, 30 are taken into consideration to measure this

---

<sup>3</sup>The term of social masks is generally used for concealing some facts: for example, unsatisfied people may tend to present a positive image for some of the approaches to hide their real point of view (Corpo, 2005)

criterion. Similarly, several number of questions are considered to measure other criterions that influence a system both to be accepted by users and to be long lasting, one of which whether a system is user-friendly or not, for which the questions numbered as 3<sup>4</sup>, 27<sup>5</sup>, 30<sup>6</sup> are expected to be answered. Quantitative information is collected using a rating scale from -2 to +2; where +2 is strongly dedicated to positive attitude, -2 is strongly dedicated to negative attitude and 0 represents “no idea or neutrality”. The questions in the questionnaire are expected to be answered for the most widespread methods as HW, TOS, RTTOS, TA, DBSR and ASDCS and our methodology, SISDS. Thus, a comparison is made possible among the methods.

The link, survey, to the questionnaire was placed at the top of each screen of the prototype to be reached easily and to be sure to be filled by all the professionals in the evaluation. It is specified as not filled at the right side of the link of survey if it is not filled by the user who connects to the system as depicted in Figure 4.2, thus collecting data electronically is made possible. The whole questionnaire is in the Appendix B and can be reached at our website, <http://www.gata.edu.tr/mebs/sisds><sup>7</sup>: an example of the questionnaire including first three questions is displayed in Figure 4.25.

## 5.2 Evaluation of the Viability of the System by Field Experts with the Questionnaire

We acknowledge that there are barriers for the acceptance of a new method to be integrated into a complex organizational environment such as hospital information systems (HIS), laboratory systems (ex. radiology information system (RIS)), or a part of Picture Archiving and Communication Systems (PACS). The adoption of standardized documentation techniques that reduce medical errors and benefit a system may require incentives such as a better diagnostic performance, gaining time, extra payment, benefits to induce professionals to switch from traditional information capture methods to methods that are more interoperable, economic, and provide a basis for better care. The acceptance of the SISDS methodology is measured by means of the satisfaction of all the related actors such as clinicians, laboratory professionals, health institutions and to some extent, patients in terms of the answers entered

---

<sup>4</sup>Do you agree that the current model provides an educational/training support?

<sup>5</sup>Do you agree that you will focus the processes better while reporting with the current model?

<sup>6</sup>Do you think that the current model can meet the overall desired benefits in terms of its all functions?

<sup>7</sup>The questionnaire screen is opened if survey, which is placed at the top of the screens after connecting the implementation by using demo user, is clicked.

by physicians. The questionnaire has been applied to 20 experts, 12 of whom are radiologists (4 of them are the head of their department), 8 of whom are clinicians, after they became accustomed to using the web-based prototype. The six approaches, namely handwriting (HW), telephone access (TA), transcriptionist-oriented systems (TOS), real time transcriptionist-oriented system (RTTOS), dictation by speech recognition (DBSR) and all structured data collected in a screen (ASDCS), which are evaluated in the questionnaire in comparison to SISDS, are frequently used and the experts are familiar with using these approaches. The question numbered 32 in the questionnaire aims to measure whether the users are familiar with the methods. The results of the questionnaire are presented in Table 5.1. The most striking result is the rating of TOS approach. Even though it is the most widespread one, it has the lowest rating of -15 among all approaches. The results of the other existing approaches of RTTOS, TA, DBSR are more or less similar (around -5); the rating of HW is relatively low, -7; the rating of ASDCS is 1, which means that the advantages and the disadvantages almost balance each other. The overall average rating of SISDS, which is 25 out of a possible maximum value of 32, seems very satisfactory. Notwithstanding a very limited number of 20 professionals are included in the questionnaire, it is clear from these results that health care professionals are not satisfied with the current approaches, especially with the most widespread TOS system and they seem to be eager to migrate from the existing approaches to a more satisfactory approach such as the one we propose. It is for sure that the medical reporting cycle might be closed as practitioners themselves record on effective systems when such systems both become easier and faster than widespread conventional methods and provide the benefits of structured and interactive recording.

### **5.3 Evaluation of the System in terms of Building a DDSS**

“Knowledge saves lives” is a common phrase in the medical community. Early, right diagnosis of diseases saves life. Even though human errors and injuries are unavoidable, they can be reduced to an important extent. Right diagnosis depends on detailed and complete information. Once the necessary information is collected in a structured format with interactivity, the knowledge-base could be constructed and well organized easily and this knowledge could be used to make medical diagnostic decision-making; data can be transformed into information, and information into knowledge. However, most of the reports haven’t sufficient information and does not make it possible decision making. The fact is that no perfect and complete method has been found yet to create an intelligent environment without sufficient

Table 5.1: Average results of the user evaluation questionnaire: The rating for each item ranges from -2 (lowest) to +2 (highest). The maximum possible total score (overall benefit) is 32 and the minimum possible total score is -32. If advantages and disadvantages balance each other then the score is 0.

Criteria for approaches	# of questions	HW	TOS	RTTOS	TA	DBSR	ASDCS	SISDS
Quality of care	10	-2	-1	0	-1	0	1	2
Data quality	6	-2	-1	0	0	0	1	2
Management of knowledge and DSS	12	-2	-2	-2	-2	-2	1	2
Research	3	-2	-2	-2	-2	-2	1	2
Reducing medical error and improving patient safety	13	-1	-2	0	1	0	2	2
Cognitive overload	7	2	2	0	1	-1	-2	1
Distribution time (faster response)	7	0	-2	1	2	0	1	1
Overall cost	6	2	-1	-2	0	1	1	1
Educational/training	10	-2	-1	-1	-2	-1	0	2
User-friendly	3	2	2	1	1	0	-1	1
User-productivity(number of reports/time)	3	2	-1	1	1	0	-1	1
Patients' satisfaction	5	0	-2	1	0	1	-2	1
Satisfaction of referring physicians	6	-1	-2	0	-2	0	1	2
Satisfaction of laboratory professionals	6	1	1	2	1	0	-2	1
EPSS	11	-2	-2	-2	-2	-1	0	2
Learning organization	10	-2	-1	-1	-2	-1	0	2
Overall benefits(total)		-7	-15	-4	-6	-6	1	25

knowledge (Andrade, 1999). Graber et al. (1994) examined the acceptance of medical DDS systems in detail: a key aspect of a system's acceptability is its user interface and it is common wisdom that medical DDS systems are most likely to succeed when they can be integrated into a clinical environment as is in SISDS, not being a stand-alone system. If the process of knowledge-base construction is highly dependent on a single individual or sample data, or carried out only at a single institution, then the survival of that system over time is in jeopardy (D. L. Hunt, Haynes, Hanna, & Smith, 1998). Moreover, a number of major challenges remain to be solved before medical DDS systems that address large medical problem domains can succeed over time. First and foremost of these challenges is medical knowledge base construction and maintenance (Graber et al., 1994). Knowledge-base maintenance is critical to the clinical validity of a medical DDS system (Graber et al., 1994). One popular approach to knowledge acquisition uses inductive concept learning to derive knowledge from examples stored in databases: some sample data are trained and then these trained data are used for later decisions as a gold test <sup>8</sup> not including the most scientific observations in most of the current DSS. However, DDS systems should augment reasoning by every new value in medical reporting and improve themselves automatically as it happens in the present study. Because, practices to cure diseases change, and the number and the diversity of diseases increases in a quicker pace now rather than that in the past.

In this section, we consider whether the data collected by using the proposed approach can be used effectively for designing DDSS without tedious data preprocessing and data preparation steps. We first would like to provide more detailed information about the data set collected by the sample esophagus report. As mentioned at the beginning of the chapter, the esophagus report contains 72 variables, 53 of which are nominal and the remaining are numeric. The input attribute list is given in Appendix E. The number of instances is 1240 <sup>9</sup>. An example to the instances is given in Appendix G: in each instance, first 72 data entries belong to the input attribute list whereas the remaining 39 data entries (either 0 or 1 to rule out or to rule in a diagnosis in a sequence in the output attribute list given in Appendix F). The instances in the collected data have some missing values for some attributes owing to the trigger based dynamic activation of data entries, or simply owing to the fact that the value is not known by the user and left unfilled. In the data set, 717 instances (57.8%)

---

<sup>8</sup>Gold test is a general term used for tests whose results are expected to yield 100 percent sensitivity and specificity.

<sup>9</sup>All collected data that include all instances with attributes belonging to real patients is in the DVD attached to this thesis in ARFF format.

belong to healthy patients and remaining 540 instances (43%) are tagged by one or more diagnoses. The number of distinct ICD-10 codes is 39. The output attribute list is given in Appendix F. Among them only three are significant: K21.9 <sup>10</sup> (250 instances, 20%), K44.9 <sup>11</sup> (126 instances, 10%) and K22.4 <sup>12</sup> (116 instances, 9.2%). The remaining ones have an average of 3.8 instances that make them infeasible for further study (Figure 5.6b). After applying a conjunctive rule learner using K21.9 and K44.9 diagnoses as target classes, we found out that both of them can be predicted with a high true positive rate (98% and 98.8% respectively) depending on the answers of two particular main data entries. Therefore, we opted for the non-trivial case of K22.4 as our target diagnosis, for which the prediction rate of the conjunctive rule learner is low (71.6%) for the patients having the corresponding health problem. Results are obtained by 10-fold cross-validation. The diagnosis of K22.4 appears in all age intervals and sexes, most notably common for older people and female sexes (Figure 5.6a). We would like to point out that, although we will mainly be presenting the results on this data set, the proposed methodology and the followed procedures are more general and our aim here is to accomplish a proof-of-concept that similar studies can be conducted on other domains as well.

Our goal is to predict the diagnosis of K22.4 for new esophagus report instances with a high sensitivity and specificity which is a classical binary classification problem. Hence, it is possible to employ various well-known classification techniques (such as Bayesian networks, decision trees, neural network, support vector machines or other functional classifiers) that are compatible with the properties of the data set. In this manuscript, we will focus on four specific representatives of different approaches. These approaches suit our data better

---

<sup>10</sup>The description of the code K21.9 is “Gastro-oesophageal reflux disease without oesophagitis”, in Turkish, “Gastro özefageal reflü hastalığı özafajit olmadan” that is defined through the main titles from top to down as K00-K93: “Diseases of the digestive system”, in Turkish, “Sindirim sisteminin hastalıkları”, K20-K31: “Diseases of oesophagus, stomach and duodenum”, in Turkish, “Özafagus mide ve duodenum hastalıkları”, K21: “Gastro-oesophageal reflux disease”, in Turkish, “Gastro özefageal reflü hastalığı” (WHO, 2007).

<sup>11</sup>The description of the code K44.9 is “Diaphragmatic hernia without obstruction or gangrene”, in Turkish, “Diyafroma fitiği gangren veya tıkanıklık olmadan” that is defined through the main titles from top to down as K00-K93: “Diseases of the digestive system”, in Turkish, “Sindirim sisteminin hastalıkları”, K40-K46: “Hernia”, in Turkish, “Fıtıklar”, K44: “Diaphragmatic hernia”, in Turkish, “Diyafagma fitiği” (WHO, 2007).

<sup>12</sup>The description of the code K22.4 is “Dyskinesia of oesophagus”, in Turkish, “Özafagus hareket bozukluğu” that is defined through the main titles from top to down as K00-K93: “Diseases of the digestive system”, in Turkish, “Sindirim sisteminin hastalıkları”, K20-K31: “Diseases of oesophagus, stomach and duodenum”, in Turkish, “Özafagus mide ve duodenum hastalıkları”, K22: “Other diseases of oesophagus”, in Turkish, “Özafagusun diğer hastalıkları” (WHO, 2007).



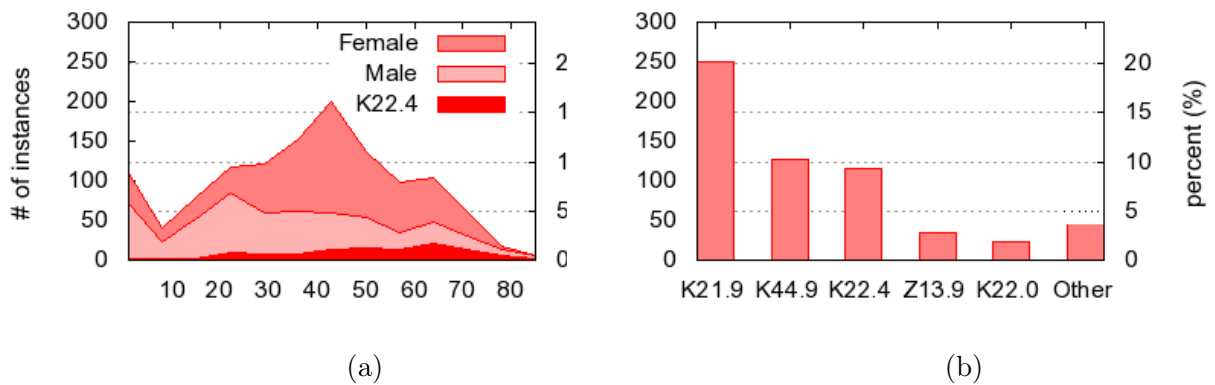

Figure 5.6: Age distribution of the data: (a) age distribution of the data set for different sexes and the target diagnosis. (b) distribution of ICD-10 diagnoses in the data set.

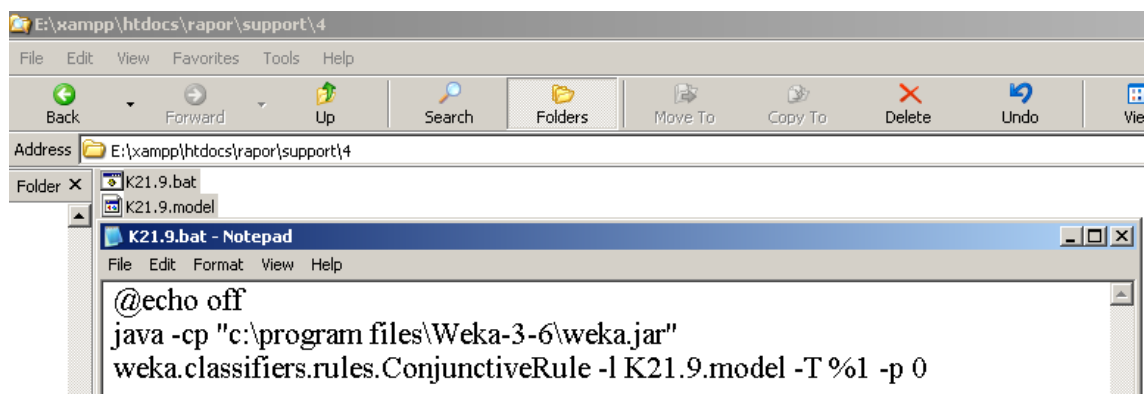

Figure 5.7: An example to compose DDSS in the prototype for K21.9: privileged users open a batch file whose name is the name of the diagnostic code for which the DSS is aimed to work, in this file the best algorithm used for that specific diagnostic code is written with its parameters and the best model observed.

than the other approaches based on the results obtained by initial 10-fold cross-validation: a Bayesian network that uses hill-climbing and a simple estimator that estimates probabilities directly from the data, a multinomial logistic regression model with a ridge estimator, a support vector classifier with sequential minimal optimization algorithm, and an alternating decision tree. The implementations of all these classifiers are available (BayesNet, Logistic, SMO and ADTree) in the Waikato Environment for Knowledge Analysis (WEKA) application suite developed at the University of Waikato. WEKA contains a collection of visualization tools and algorithms for data analysis and predictive modeling<sup>13</sup>. Our web-based prototype has the capability to export the collected data in a format that can be directly imported by WEKA (as an ARFF file), so that these (and other) classifiers can be tested with ease and a decision support system can be developed rapidly. Our application in which most of the machine learning algorithms are embedded from the Weka tool allows to work for other machine learning algorithms with an easy definition in a directory, where the codes works. Privileged users open a batch file whose name is the name of the diagnostic code for which the DSS is aimed to work, in this file the best algorithm used for that specific diagnostic code is written with its parameters and the best model observed by analysis mentioned in the following paragraphs for that diagnostic code is specified<sup>14</sup> as an example depicted in Figure 5.7, there is no need any computer expertise to build a DDSS for other diagnosis codes<sup>15</sup>. In our experiments, we used the default parameters of the classifiers and applied 10-fold cross-validation to prevent overfitting. In  $k$ -fold cross-validation, the data set is partitioned into  $k$  equally sized subsets. The analysis is performed on  $k - 1$  subsets (training set), and then validated on the remaining one (testing set). 10-fold cross-validation is known to perform well for moderate sized data sets. To reduce variability, multiple rounds (in our case, again 10) of cross-validation are performed using different seeds, and the validation results are averaged over the rounds. In Logistic and SMO classifiers, the nominal attributes are transformed into binary numeric attributes and normalized.

We first applied the algorithms to the data set normally without any additional processing steps. The overall prediction rates are high for all classifiers ( $> 93.5\%$ ) and the SMO algorithm has the best accuracy rate (96.7%)( Table 5.2). The results in a graphical representation is also presented in Figure 5.9 as regular. However, when we analyse the results

<sup>13</sup>Freely available from <http://www.cs.waikato.ac.nz/ml/weka/>

<sup>14</sup>the model could be observed easily by WEKA tool after deciding the best machine learning algorithms including best parameters and best meta learning algorithms.

<sup>15</sup>More detailed information to build a DDSS can be found in the “ReadMe” file put in the directory named “SISDS Methodology Software Codes”.

Table 5.2: For K22.4 diagnosis, average accuracies of the classification algorithms that are applied both normally without any additional processing steps in first line categorized as “regular” and with using a cost matrix that assigns a weight of 10.0 to instances with K22.4 diagnosis and 1.0 otherwise in second line categorized as “Cost Sen.”. TPR: True Positive Rate; TNR: True Negative Rate; A: Overall accuracy; the values at the right of the TPRs, the TNRs and the accuracies designate the variances.

	ADTree			BayesNet		
	TNR	TPR	A	TNR	TPR	A
Regular	98,24 ± 0,00	76,21 ± 0,01	96,19 ± 0,00	97,34 ± 0,00	56,30 ± 0,03	93,52 ± 0,00
Cost Sen.	93,27 ± 0,00	84,13 ± 0,01	92,41 ± 0,00	95,29 ± 0,00	85,44 ± 0,02	94,37 ± 0,00
	Logistic			SMO		
	TNR	TPR	A	TNR	TPR	A
Regular	97,64 ± 0,00	77,67 ± 0,04	95,77 ± 0,00	98,61 ± 0,00	78,43 ± 0,01	96,70 ± 0,00
Cost Sen.	95,81 ± 0,00	82,13 ± 0,01	94,53 ± 0,00	94,85 ± 0,00	86,56 ± 0,00	94,07 ± 0,00

in detail, it can be observed that true positive rates (TPR), i.e. correct prediction rate for patients with K22.4 diagnosis, are low ( $< 78.4\%$ ). In our case, TPR (rule in K22.4) is as important as the true negative rate (TNR) (rule out K22.4), i.e. correct prediction rate for healthy patients (in the sense that not suffering from K22.4 diagnosis). TPR is calculated by the evaluation of 116 instances as opposed to 1124 instances for TNR (with a ratio of 1/10.3), which means that the data set is *unbalanced* and prone to bias in the class-wise classification results. This situation emerges as a common feature of most diagnostic related medical data sets. One possible way to deal with this problem is to use *cost-sensitive classification*. In cost-sensitive classification, classes have different costs associated with them and the training instances are reweighted according to the total cost assigned to each class using a cost matrix. The classes with less number of instances can be assigned higher costs to reduce the number of false predictions, and consequently increase the accuracy, for that class (in our case, TPR). Note that, this means that the prediction rates for other class(es) will inevitably fall as they will relatively have lower costs (and thus the number of false predictions in those classes will increase). In our experiments, we tested several cost matrices and the best results have been obtained by a cost matrix that assigns a weight of 10.0 to instances with K22.4 diagnosis and 1.0 otherwise. As it can be seen from Table 5.2, this leads to a significant increase in TPRs for all classifiers (almost 30% increase for the BayesNet and  $\approx 8\%$  for the

Table 5.3: For K22.4 diagnosis, average accuracies of the classification algorithms with parameter selection using information gain attribute evaluation (IG) and principal component analysis (PCA) with 8 to 16 and 32 attributes. TPR: True Positive Rate; TNR: True Negative Rate; A: Overall accuracy; the values at the right of the TPRs, the TNRs and the accuracies designate the variances.

	ADTree			BayesNet		
	TNR	TPR	A	TNR	TPR	A
IG (8)	98,21 ± 0,00	77,41 ± 0,00	96,28 ± 0,00	98,61 ± 0,00	72,67 ± 0,00	96,16 ± 0,00
(16)	98,49 ± 0,00	77,05 ± 0,01	96,48 ± 0,00	98,22 ± 0,00	75,61 ± 0,00	96,12 ± 0,00
(32)	98,32 ± 0,00	76,88 ± 0,01	96,32 ± 0,00	97,35 ± 0,00	71,64 ± 0,04	94,94 ± 0,00
PCA (8)	99,21 ± 0,00	67,59 ± 0,02	96,25 ± 0,00	92,96 ± 0,00	85,61 ± 0,04	92,29 ± 0,00
(16)	99,08 ± 0,00	73,12 ± 0,01	96,66 ± 0,00	91,56 ± 0,00	88,81 ± 0,01	91,30 ± 0,00
(32)	98,47 ± 0,00	71,04 ± 0,12	95,90 ± 0,00	87,74 ± 0,00	92,92 ± 0,01	88,23 ± 0,00
	Logistic			SMO		
	TNR	TPR	A	TNR	TPR	A
IG (8)	98,45 ± 0,00	75,09 ± 0,02	96,26 ± 0,00	98,67 ± 0,00	74,04 ± 0,01	96,34 ± 0,00
(16)	98,46 ± 0,00	77,32 ± 0,01	96,48 ± 0,00	98,48 ± 0,00	77,92 ± 0,02	96,55 ± 0,00
(32)	97,99 ± 0,00	78,28 ± 0,01	96,15 ± 0,00	98,58 ± 0,00	76,98 ± 0,02	96,55 ± 0,00
PCA (8)	98,65 ± 0,00	55,86 ± 0,16	94,64 ± 0,00	99,41 ± 0,00	27,41 ± 0,60	92,65 ± 0,00
(16)	98,66 ± 0,00	74,40 ± 0,01	96,36 ± 0,00	98,80 ± 0,00	72,40 ± 0,00	96,37 ± 0,00
(32)	98,02 ± 0,00	76,11 ± 0,02	95,98 ± 0,00	98,42 ± 0,00	74,92 ± 0,00	96,22 ± 0,00

others) despite a small loss of 2%-4.9% in TNRs. The results in a graphical representation is also presented in Figure 5.9 as cost sensitive. Although BayesNet and Logistic classifiers have higher TNRs, SMO is better in TPR and has a similar but slightly lower TNR, and can be a better choice.

The data set under study consists of over 70 attributes. Experiments show that useless attributes cause the performance of learning schemes to deteriorate (Witten & Frank, 1997). A possible way to prevent this situation is to apply attribute selection techniques to the data set as a pre-processing step, and reduce the number of attributes. In our experiments, we tested two such techniques and determined a set of 8, 16 and 32 attributes: *information gain attribute evaluation* (IG) that evaluates the worth of an attribute by measuring the information gain with respect to the target class, and *principal component analysis* (PCA) in which attribute reduction is accomplished by choosing eigenvectors that account for a specified percentage of the variance in the data set (Chow, 2003). PCA generates a set of transformed attributes that are different from the original ones (Chow, 2003). As it can

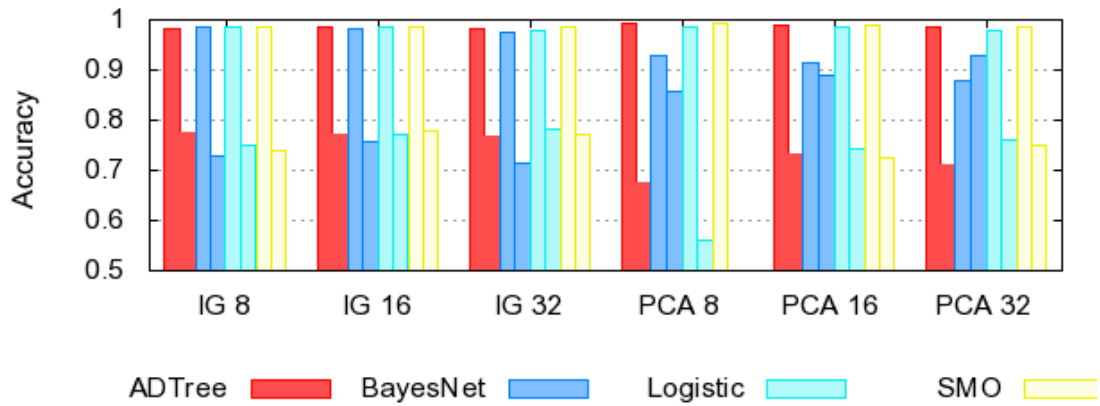

Figure 5.8: Average classification accuracy with parameter selection using information gain attribute evaluation and principal component analysis with 8 to 16 and 32 attributes: left bars indicate TNR and right bars indicate TPR.

be seen from Table 5.3, for IG, the results stay almost the same for ADtree, Logistic and SMO classifiers, and are better for the BayesNet classifier in terms of both TPRs and TNRs. For PCA, the results seem similar (slightly higher TNRs and lower TPRs), except BayesNet in which TPRs increase dramatically to 85.6%, 88.8%, and 92.9% with much sacrifices for TNRs, 93.0%, 91.6%, and 87% for 8 to 16 and 32 attributes respectively. A graphical representation of the results is depicted in Figure 5.8. Overall, including more attributes increases the TPRs for all algorithms which signifies that all attributes, rather than small subset, add a value to the classification results (probably, on account of small number of instances with K22.4 diagnosis in certain age groups).

An obvious approach to making decisions more reliable is to combine the output of different models. Several meta learning methods that work well in practice are bagging, boosting and stacking to reduce bias and variance. The meta learning algorithms of bagging and stacking reduce the variance substantially without effecting bias, and boosting does it vice versa. Boosting algorithms consist of iteratively learning weak classifiers with respect to a distribution and adding them to a final strong classifier; when they are added, they are typically weighted in some way that is usually related to the weak learners' accuracy; after a weak learner is added, the data is reweighed (Wikipedia, 1996a). Examples that are misclassified gain weight and examples that are classified correctly lose weight (Wikipedia, 1996a). In bagging (bootstrap aggregating), the underlying classification algorithm is used to bootstrap datasets and average the predictions of the ensemble (Wikipedia, 1996b). It is a machine learning ensemble meta-algorithm to improve machine learning of classification

Table 5.4: For K22.4 diagnosis, average accuracies of the classification algorithms with bagging and bagging together with cost sensitive analysis: TPR: True Positive Rate; TNR: True Negative Rate; A: Overall accuracy; the values at the right of the TPRs, the TNRs and the accuracies designate the variances.

	ADTree			BayesNet		
	TNR	TPR	A	TNR	TPR	A
Bagging	98,33 ± 0,00	76,80 ± 0,01	96,32 ± 0,00	97,51 ± 0,00	59,40 ± 0,05	93,94 ± 0,00
CS. w/ Bagging	94,77 ± 0,00	84,13 ± 0,01	93,77 ± 0,00	96,32 ± 0,00	83,01 ± 0,01	95,09 ± 0,00
	Logistic			SMO		
	TNR	TPR	A	TNR	TPR	A
Bagging	97,70 ± 0,00	78,19 ± 0,01	95,86 ± 0,00	98,58 ± 0,00	77,32 ± 0,02	96,57 ± 0,00
CS. w/ Bagging	96,50 ± 0,00	81,64 ± 0,01	95,11 ± 0,00	95,85 ± 0,00	84,81 ± 0,02	94,81 ± 0,00

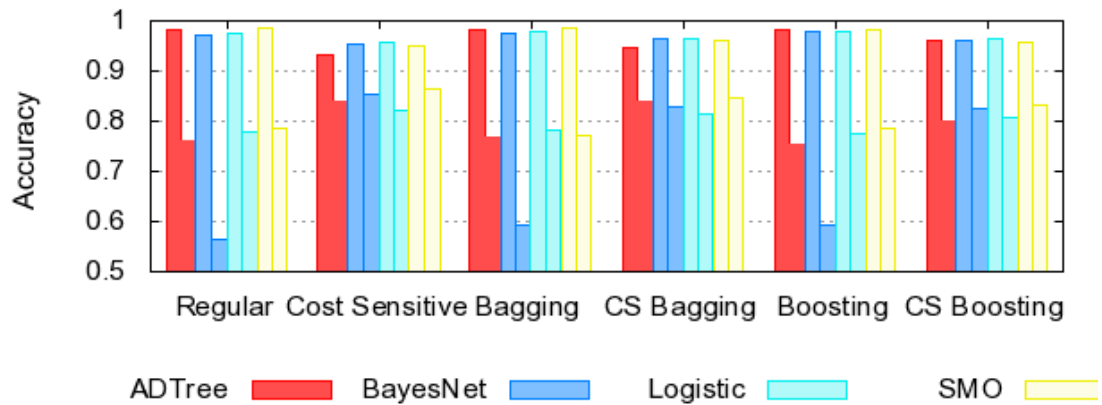

Figure 5.9: Average accuracies of classification algorithms when applied to the data set: (a) normally without any additional processing steps, (b) with cost-sensitive classification, (c) with bagging, (d) with both cost-sensitive classification and bagging, (e) with boosting and (f) with cost-sensitive classification and boosting; left bars indicate TNR and right bars indicate TPR.

Table 5.5: For K22.4 diagnosis, average accuracies of the classification algorithms: (a) with boosting, (b) with cost-sensitive classification and boosting, (c) with both using boosting and information gain attribute evaluation (IG) with 8 to 16 and 32 attributes, and (d) with both using boosting and principal component analysis (PCA) with 8 to 16 and 32 attributes. TPR: True Positive Rate; TNR: True Negative Rate; A: Overall accuracy; the values at the right of the TPRs, the TNRs and the accuracies designate the variances.

	ADTree			BayesNet		
	TNR	TPR	A	TNR	TPR	A
Boosting	98,16 ± 0,00	75,16 ± 0,02	96,02 ± 0,00	98,00 ± 0,00	59,22 ± 0,12	94,38 ± 0,00
CS. w/ Boosting	95,93 ± 0,00	80,00 ± 0,04	94,44 ± 0,00	96,03 ± 0,00	82,58 ± 0,03	94,76 ± 0,00
	Logistic			SMO		
	TNR	TPR	A	TNR	TPR	A
Boosting	97,70 ± 0,00	77,50 ± 0,04	95,81 ± 0,00	98,06 ± 0,00	78,52 ± 0,04	96,23 ± 0,00
CS. w/ Boost	96,25 ± 0,00	80,79 ± 0,03	94,78 ± 0,00	95,67 ± 0,00	83,11 ± 0,05	94,51 ± 0,00

and regression models in terms of stability and classification accuracy (Wikipedia, 1996b). The results are presented in Table 5.4 for bagging, and in Figure 5.9. TPRs, one of the most important criterion for us to choose the best algorithm, for the cost sensitive case are relatively higher than the other methods with a modest lost for TNR. The bar of TPR for SMO with cost sensitive meta learning algorithm seems the highest in this section. The bars for the algorithms with meta learning methods of IG and PCA are in terms of the TPRs don't seem satisfactory to choose one of them for DDSS in Figure 5.8. Similarly, the bars of algorithms with boosting together with IG attribute evaluation and PCA are not competent. SMO with cost sensitive analysis specified as "cost sensitive" in Figure 5.9 is superior to the others in TPR in height and can be a better choice, although the other classifiers have slightly higher TNRs. The combined effect of boosting and parameter selection on different classification algorithms can be seen in Table 5.6 and in Figure 5.10 in graphical presentation. These algorithms doesn't produce better results than the SMO with cost sensitive analysis either. A DDSS was established in the SISDS methodology in accordance with the evaluation of data mentioned in previous paragraphs<sup>16</sup>. The established DDSS was tested in view of

<sup>16</sup>The established DDSS for specific diagnoses can be tested together with the SISDS methodology at the website, <http://www.gata.edu.tr/mebs/sisds>. All implemented codes together with established DDSS and the Database on which implemented codes run are in the DVD attached to this thesis and the prototype could be installed at any computer as well to test.

Table 5.6: For K22.4 diagnosis, average accuracies of the classification algorithms (a) with boosting, (b) with cost-sensitive classification and boosting, (c) with both using boosting and information gain attribute evaluation (IG) with 8 to 16 and 32 attributes, and (d) with both using boosting and principal component analysis (PCA) with 8 to 16 and 32 attributes. TPR: True Positive Rate; TNR: True Negative Rate; A: Overall accuracy; the values at the right of the TPRs, the TNRs and the accuracies designate the variances.

	ADTree			BayesNet		
	TNR	TPR	A	TNR	TPR	A
BoostIG (8)	98,09 ± 0,00	75,09 ± 0,06	95,95 ± 0,00	98,41 ± 0,00	73,20 ± 0,02	96,05 ± 0,00
(16)	98,04 ± 0,00	76,71 ± 0,06	96,05 ± 0,00	98,20 ± 0,00	75,34 ± 0,04	96,06 ± 0,00
(32)	97,97 ± 0,00	75,60 ± 0,03	95,87 ± 0,00	97,83 ± 0,00	66,64 ± 0,14	94,91 ± 0,00
BoostPCA (8)	98,37 ± 0,00	70,61 ± 0,05	95,76 ± 0,00	98,70 ± 0,00	65,43 ± 0,08	95,58 ± 0,00
(16)	98,46 ± 0,00	70,79 ± 0,06	95,85 ± 0,00	98,90 ± 0,00	66,46 ± 0,05	95,86 ± 0,00
(32)	98,17 ± 0,00	71,31 ± 0,05	95,66 ± 0,00	98,81 ± 0,00	65,86 ± 0,06	95,72 ± 0,00
	Logistic			SMO		
	TNR	TPR	A	TNR	TPR	A
BoostIG (8)	98,41 ± 0,00	75,61 ± 0,02	96,27 ± 0,00	98,69 ± 0,00	74,82 ± 0,01	96,43 ± 0,00
(16)	98,39 ± 0,00	76,47 ± 0,03	96,34 ± 0,00	98,56 ± 0,00	78,70 ± 0,01	96,69 ± 0,00
(32)	97,64 ± 0,00	77,23 ± 0,02	95,73 ± 0,00	98,01 ± 0,00	77,93 ± 0,03	96,14 ± 0,00
BoostPCA (8)	98,24 ± 0,00	59,66 ± 0,34	94,63 ± 0,00	98,34 ± 0,00	62,85 ± 0,30	95,02 ± 0,01
(16)	98,50 ± 0,00	73,29 ± 0,03	96,14 ± 0,00	98,67 ± 0,00	72,06 ± 0,01	96,17 ± 0,00
(32)	97,88 ± 0,00	75,61 ± 0,05	95,81 ± 0,00	98,34 ± 0,00	75,27 ± 0,01	96,17 ± 0,00



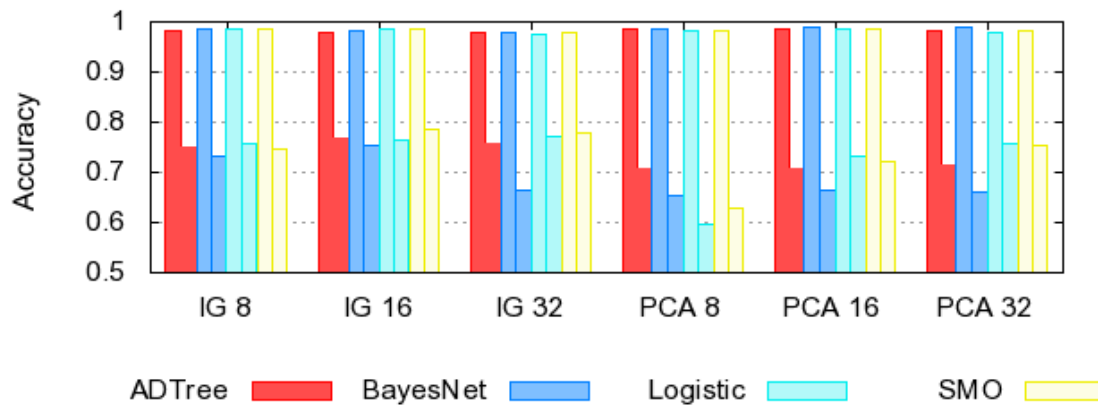

Figure 5.10: The average classification accuracy of boosting together with information gain attribute evaluation and principal component analysis with 8 to 16 and 32 attributes.

some criteria in the expertise of field experts to be sure whether it is correctly built. For instance, in the report, if “the feature of the peristalsis wave during the transition of the contrast media” is entered as tertiary, then the probability of diagnosis for K22.4 has to increase, as in our report depicted in Figure 5.11, from 82.50 without tertiary to 99.70 with entered tertiary. The established DDSS responded as expected.

Clinicians, in general, prediagnose their patients and order some laboratory tests to be sure in terms of their diagnosis. In this manner, laboratory professionals, first of all, test the prediagnosis put forward by clinicians and conclude about the prediagnosis. Likewise, the system is designed to serve any specific diagnosis DSS. In our methodology, laboratory professionals can choose a specific diagnosis and may test its probability( Figure 5.12). It seems that we move from rule-based static understanding to a more dynamic one, where probability of DDSS for specific diagnoses are acquired automatically from current data. A clear advantage of the present methodology is that the probability assignment to the different diagnostic possibilities in any particular situation does not have to be arbitrarily assigned by the specialist, but is automatically provided by the method, in agreement with the acquired experience.

The general results are presented in Table H.2 altogether <sup>17</sup>.

<sup>17</sup>The results about all detailed 10-fold cross-validations belonging to machine learning algorithms used in the study are in the DVD attached to this thesis in excel format.

## 5.4 Testing of the System's Real World Performance

An extremely effective method for changing behavior is to make reporting process as fast or faster, to comply with a recommendation or guideline than not to comply (Payne, 2000). In order to evaluate the performance of the proposed SISDS approach, we compared its real-life use with the most widespread medical reporting approach of transcriptionist-oriented systems (TOS). We selected 10 esophagus DICOM images out of 253 esophagus DICOM images belonging to real patients<sup>18</sup>. Two of these images were normal cases and the remaining were not normal. Two of which indicate a diagnosis of K22.4. Each of 8 experts generated reports of these 10 DICOM esophagus images first by using the TOS approach without being accustomed to using the SISDS approach and then by using the SISDS approach after being familiar with. Approximately 10 minutes of use is required to learn the SISDS system. The patient names in the DICOM images were anonymized and the experts weren't able to compare the findings in the images during data entry for the same images in both systems. We analyzed both approaches based on two criteria: the total time required to enter data, and the rate of successful diagnosis. The screenshot of the SISDS method for generating medical reports and applying DDSS is exemplified in Figure 5.11.

**In terms of time and cost:** in TOS approach, each of 10 reports was recorded independently nonstop by 8 experts as speech. The total length of recordings from the beginning to the end is 880 minutes, which also corresponds to the time required to complete the entire process, averaging 11 minutes of data recording time for a single case not including the transcriptionist's time or the professionals's verification time. Still, the recordings need to be transcribed in machine readable format later by transcriptionists, and yet to be approved by the experts and then be disseminated for use. In SISDS approach, the reports were stored in the database in a machine readable format in a total time of 960 minutes and ready to be disseminated, averaging 12 minutes data input time for a case. The difference in terms of time to generate reports between two systems is not statistically significant. Furthermore, we believe that input time for SISDS may be improved by more practices by which users become more familiar with the SISDS approach. When the time of transcription and approval processes are taken into account, which also depends on the number of available transcriptionists, the time to obtain the final reports would be much longer for the TOS approach compared to the SISDS methodology. Note that, in TOS approach the reports must still be submitted to the radiologist for approval, another cause of using up of time

---

<sup>18</sup>The anonymized DICOM images belonging to real patients is in the DVD attached to this thesis.

to disseminate the reports. In this sense, the test of the system suggests that the system nested together with two sub methods as structured and interactive methods becomes faster than TOS approach, as well as, it collects high quality data. Structured design is processed with our algorithm to help interactivity and thus, standardization operates in a cost-effective manner in terms of time and cost for needed transcriptionists in TOS approach.

Economically, some healthcare providers show substantial savings as transcription is diminished or eliminated while some of the return on investment (ROI) could be quite impressive <sup>19</sup>.

**In terms of diagnosis success:** With TOS approach, only 2 out of 8 experts diagnosed both of the two K22.4 cases correctly, 3 experts diagnosed one of the cases, hence the overall success rate of diagnosis is 43.75% (7 out of 16). On the other hand, for the SISDS methodology, 6 experts diagnosed 2 of the K22.4 diagnoses in 10 cases correctly, 1 expert diagnosed just 1 of them correctly, that is, only one case among all cases with K22.4 was not diagnosed correctly out of 16 cases resulting in a success rate of 93.75%. We can conclude that with the SISDS approach, the established DDSS that is mentioned in the previous subsection proves its success in guiding professionals during diagnosing process. We think that when doctors become aware of the great achievements of these kinds of programs where the quality of health care is concerned, s/he will be volunteer to adopt similar programs as soon as possible in their daily clinical practices.

Furthermore, the analysis of the resulting reports revealed and confirmed that many details are assumed to be common knowledge and left out of the reports in TOS recording process. On the contrary, all necessary details are included in the reports that are generated by SISDS as structured and are ready to be used for further analysis, research and building DDSS. Generating reports with the method introduced in this study guarantees the decrease in overall response time and the increase in the accuracy both in terms of data collection and in terms of diagnostic performance when compared to the TOS approach. One of the disadvantages of the SISDS system when compared to the TOS approach is that the professionals must look away from the film or patient, often repeatedly, while generating the report. A speech interface into the SISDS should to be integrated to settle the look-away problem and to obtain better results without both using keyboard and looking at monitor in a bilateral interactive, dynamic and structured (controlled vocabulary) understanding as a future study.

---

<sup>19</sup>In the case where 400,000 transcriptionist are needed in the USA alone (TransTimeMed, 2002)).

## View Record

Changes are saved.

### Diagnosis Support

**Diagnosis:** K22.4  
**Probability (%)** 99.70

**Patient ID:** 02

**Patient:** Test Diagnostic DSS

**Birth Date:** 01/01/1940

**Age:** 68

**Gender:** Male

**Date:** 12/02/2007

**Type:** Test

**Pre-diagnosis:**

**Clinic**

**Information:**

**Description:**

**Report:**

Text

English

#### Esophagus (Ózofago)

The position of the patient is **prone-oblique**. The contrast media used in oral way is **barium**. **There isn't** leakage of contrast media out of the lumen. The transition of the contrast media from the esophagus to stomach is **as normal without delay**. The feature of the peristalsis wave during the transition of the contrast media is **regular**. The section in which peristalsis waves are observed is **in esophagus**. **There isn't** narrowness without a clear expansion in the esophagus during the transition of the contrast media. The mucosal relief of the esophagus is **normal**. **There isn't** a filling defect in the esophagus. **There isn't** ulcerated lesion in the mucosa of the esophagus. **There isn't** an outpouching in the esophagus. **There isn't** significant abnormal dilatation in esophagus during the transition of contrast media. **There is** surgical operation in the esophagus. The width of anastomosis line is **normal**. **There isn't** hernia in the distal esophagus. **There isn't** a gastro-esophagus reflux.

**Report Detail:**

K22.4

Select

Select

Select

Select

**Diagnosis:**

Close report.

Save

Apply Diagnosing Support

Expert Opinion

Figure 5.11: Screenshot of the SISDS method for generating medical reports: the report is entered by the user and then the button of Apply Diagnosing Support is clicked to take some advises about probable diagnoses. The diagnosing support is depicted at the top of the page as Diagnosing Probability of K22.4, 99.70

### Diagnosis Support

Diagnosis	Probability (%)
K44.9	91.10

**Patient ID:** 2030017  
**Patient:** duran gurkanaya  
**Birth Date:** 23/11/1971  
**Age:** 36  
**Gender:** Male  
**Date:** 23/11/2006  
**Type:** G.H

**Pre-diagnosis:**  
**Clinic Information:**  
**Description:**

**Report:** Text

**Esophagus (Özofagus)**  
 The position of the patient is **prone oblique**. The contrast media used in oral way is **barium**. **There isn't** leakage of contrast media out of the lumen. The transition of the contrast media from the esophagus to stomach is **as normal without delay**. The feature of the peristalsis wave during the transition of the contrast media is **primary**. **There isn't** narrowing without a clear expansion in the esophagus during the transition of the contrast media. The mucosal relief of the esophagus is **normal**. **There isn't** a filling defect in the esophagus. **There isn't** ulcerated lesion in the mucosa of the esophagus. **There isn't** an outpouching in the esophagus. **There isn't** significant abnormal dilatation in esophagus during the transition of contrast media. **There isn't** surgical operation in the esophagus. **There is** hernia in the distal esophagus. The type of esophagus is **sliding**. **There is** a gastro-esophagus reflux.

**Report Detail:**

Close report.

**Diagnosis:**

Tanı seç
K21.9
<b>K44.9</b>
K22.4
Z13.9
K22.0

Figure 5.12: Screenshot of the SISDS method for generating medical reports: The system is designed to serve any specific diagnosis DSS: laboratory professionals can choose a specific diagnosis and may test its probability. The report is entered by the user and then the button of Apply DSS specific to a diagnosis is clicked to take some advises about probable diagnoses after a specific diagnostic code is chosen. The diagnosing Support is depicted at the top of the page as Diagnosing Probability of K44.9, 91.10.

## 5.5 Summary of the Evaluation and the Testing of the SISDS Methodology

A general evaluation of the questionnaire and the test of the SISDS methodology is summarized in Table 5.7 to display what has been established in the methodology by means of some criteria and how much SISDS is successful to cover these criteria as the degree of advantages/shortcomings. The criteria as “quality of care”, “data quality”, “management of knowledge”, “research”, “easy way of building DDSS”, “increase of diagnostic accuracy”, “easy way of designing report structure”, “reducing medical error and improving patient safety”, “satisfaction of referring physicians”, “EPSS”, “educational/training” and “Learning organization” seem well-established in the SISDS Methodology, ++. The criteria as “reducing cognitive overload”, “distribution time (faster response)”, “overall cost”, “user-friendly”, “user-productivity(number of reports/time)”, “patients’ satisfaction” and “satisfaction of laboratory professionals” seem better, +, than the most of the common approaches. On the other hand, the criterion “removing look away problem”, which is an important consideration for the satisfaction of laboratory professionals while generating medical reports, doesn’t seem satisfactory in the methodology. However, the SISDS methodology encompasses most of the positive features of the common approaches in an implementation together with some other features not included in the common approaches as “increase of diagnostic accuracy”, “easy way of designing report structure”, “easy way of building DDSS with most recent information”, “reducing medical error and improving patient safety” , “EPSS” and “Learning organization”.

Table 5.7: A general evaluation of the questionnaire and the test of the SISDS methodology: The table is sorted by the degree from the best results to the worst results. The four-level evaluation scale is defined as follows: relatively low (--), low (-), moderate (0), high (+) and relatively high (++) .

<b>Criteria for approaches</b>	<b>Degree of advantages/shortcomings</b>
Quality of care	++
Data quality	++
Management of knowledge	++
Research	++
Easy way of building DDSS with most recent information	++
Increase of diagnostic accuracy	++
Easy way of designing report structure	++
Reducing medical errors and improving patient safety	++
Satisfaction of referring physicians	++
EPSS	++
Educational/training	++
Learning organization	++
Reducing cognitive overload	+
Reduced distribution time (faster response)	+
Overall cost	+
User-friendly	+
User-productivity(number of reports/time)	+
Patients' satisfaction	+
Satisfaction of laboratory professionals	+
Removing look away problem	-

# CHAPTER 6

## CONCLUSION

In this manuscript, to conclude, we presented the formal definition of the SISDS method, which was built as a medical application, especially for medical reporting, together with a proof-of-concept implementation that aims to show its effectiveness in several ways. The SISDS methodology encompasses such as “quality of care”, “data quality”, “management of knowledge”, “research”, “easy way of building DDSS with most recent information”, “increase of diagnostic accuracy”, “easy way of designing report structure”, “reducing medical errors and improving patient safety”, “satisfaction of referring physicians”, “EPSS”, “educational/training”, “learning organization”, “reducing cognitive overload”, “reduced distribution time (faster response)”, “less overall cost”, “user-friendly”, “user-productivity(number of reports/time)”, “patients’ satisfaction” and “satisfaction of laboratory professionals” compiled together in an implementation.

The SISDS method aims to cover the different needs of all the actors in the field such as laboratory professionals, examining physicians, institutions, patients, government and health insurance companies. However, current approaches such as HW, TOS, RTTOS, TA and DBSR attach importance to the priorities of a very limited number of actors, usually laboratory professionals who aim to generate the highest number of medical reports each time. The present medical reporting method brings a new understanding for writing or displaying generated reports from the point of view of their readers. It is possible for physicians to see reports generated by laboratory professionals either in a free-text form or in a structured nested hierarchical form in which abnormal conditions are color-coded to draw the attention of physicians to these sections. Furthermore, clinicians may consult other colleagues in their native language by transforming the report into other languages instantly as is, error free in transformed reports. In other words, report structure and content are ultimately tailored to suit the needs of both clinicians and other actors such as health insurance corporations.



The payment of some laboratory tests by health insurance corporations is made possible in USA as long as some proclaimed necessary information is included in contents of generated reports for these tests. These kinds of procedures dictated by corporations are definitely going to be widespread all around the world if health expenditures increase at high pace and threaten the economies of the developing/developed countries. These kinds of policies are required to provide the quality of healthcare services. In this case, SISDS is a prompt viable solution to realize these kind of policies.

Cognitive overload is one of the most important bottlenecks for the success of any medical system by which data are entered, processed and viewed. There exists a direct relationship between the amount and complexity of information that need to be entered/processed by users and the cognitive load. Hence, reducing the amount and complexity of information would also reduce the inefficiency and cognitive load. The SISDS Methodology inherently leads to a nested and hierarchical structure, in which data entered at a certain point determines the information flow and content, and consequently, the related data that should be entered and displayed. Although the total number of possible realizations may be large in such a setting (due to the combinatorial expansion), by *interactively walking on the necessary steps* while completing the report, the number of data entries that need to be specified can be reduced considerably – a process which effectively corresponds to following a path on the hierarchy.

The proposed methodology is evaluated for several criterions and the results of evaluation have shown that the SISDS approach, rather than current approaches, can be used effectively. The feedback that we received from the users of the implemented prototype and the results from the evaluations explained in Chapter 5 indicate that the proposed method is a promising approach for achieving the aim of effective data collection, reporting and diagnostic decision supporting as an alternative to the most common approaches (Section 2.2). The real world performance of the SISDS approach is tested with the prototype implementation put into practice at several radiology departments. The established DDSS on the methodology depending on the collected data by the methodology proves its success in guiding professionals during diagnosing process with a success rate of 93.75%; the success rate is 43.75% for the most widespread transcriptionist-oriented systems (TOS). The overall average rating of SISDS by medical professionals in comparison to other most common approaches in a questionnaire, which is 25 out of a possible maximum value of 32, seems highly satisfactory. Notwithstanding, a very limited number of 20 professionals are included in the questionnaire, it is clear from these results that health care professionals are not satisfied

with the current approaches, especially with the most widespread approach, TOS, having the lowest rating of -15, and they seem to be eager to migrate from the existing approaches to a more satisfactory approach such as the one we propose. The quantitative results of the applied testbed of the SISDS method and the feedbacks that we received from the users who evaluated SISDS alongside with other existing methods prove that the proposed method is more effective in many perspectives, such as facilitating the complete and the accurate data collection process and providing opportunities to build DDSS without tedious pre-processing and data preparation steps. It mainly helps health care professionals practice better medicine by reducing the turn around time to disseminate medical reports.

In all sectors, technological diseases, one of which is repetitive stress injury (RSI) which is caused by the overusage of the keyboard by transcriptionists to dictate a huge number of medical reports during the reporting phase into a free-text machine readable format either from speeches of professionals in real time or from speeches in speech recording devices, cost too much for economies all around the world. The transcription section or auxiliary procedures to write reports is removed with interactive recording in the SISDS methodology. The initial skeleton of a medical report with normal values are generated by the system. The report-wide triggers enable the report to be rearranged based on the data entries in which normal values is usually proposed including the required nominal values in menus. Most of the sections of medical reports are written by the methodology, as in the case of esophagus report for which above 90 percent of the report is generated by the system. This, as a result, would reduce the technological diseases caused by mass usage of keyboards considerably.

Note that although it is mainly developed for medical applications, the SISDS methodology is a more general and may as well be applied for other fields different from medicine.

To conclude, the SISDS methodology provides

1. an easy way for domain experts to define reports in a textual form without extensive computer knowledge,
2. an establishment of building data and information infrastructure to support quality,
3. to make it unnecessary to use any transcriptionist or auxiliary procedures to write reports,
4. a high degree of timeliness and accuracy, simple report distribution,
5. multifunctional capabilities such as drawing the attention of practitioner to important sections of the report, alerting him about a diagnosis or giving advises at the time of

- entry,
6. all necessary information for the evaluation of other physicians,
  7. more accurate diagnostic information,
  8. an easy way of building DDSSs and,
  9. a capability to reduce medical errors,
  10. a decrease of technological diseases, which is caused by transcribing many medical reports, by rearranging reports by itself and proposing its normal values including required nominal values in the sections of data entries,
  11. an ability to consult other experts in their native languages by translating medical reports into other languages instantly without any effort.

# CHAPTER 7

## DISCUSSION

Over the past fifteen years, patient safety has become an important issue for medical systems around the world. In 1999, the Institute of Medicine released an alarming report, *To Err Is Human*, which estimated that between 44,000 and 98,000 people die each year from medical errors in hospitals in the United States: the lower estimate places medical errors as the eighth leading cause of death in the U.S whereas the higher estimate places medical errors as the fifth cause of death (IOM, 1999). Similarly, a 2004 analysis of billing information for 37 million Medicare patients by Health Grades, a health-care-quality company, estimated that 16 types of patient safety errors resulted in an estimated 19 billion Dollar in extra costs and nearly 200,000 unnecessary deaths in hospitals across the U.S. between 2000 and 2002 (DynamicChiropractic, 2004). The expected decrease in variation and increase in compliance with evidence-based recommendations should decrease the error rate and enhance patient safety (D. Bell & Greenes, 1994). Likewise, in this study we propose a new methodology which adopts a systematic approach to improve medical reporting processes by reducing variability and minimizing errors. The interactivity with the user in our study, “interactive walk on necessary steps”, and free-text like inline structured data entry have many advantages that allow information to be captured at the point of care and eliminate the need for a transcriptionist or auxiliary procedures to write reports, which is a cause of medical errors. In particular, the end report is automatically generated while structured fields are filled interactively in a natural form which is similar to the final report. More specifically, we focus on the process of data entry and report generation. The interactivity with a versatile, user- and problem-driven, scalable and dynamic reporting understanding is the proposed solution to avoid inefficiency, cognitive overload and medical errors. In the present study, proper interpretation of images or patients is formulated and attention is provided by guiding professionals through necessary details with predefined sections in great concentration

to prevent “lesion blindness”. Moreover, in order to prevent this, in our implementation, the presentation layer is enriched with visual clues. Data fields having abnormal values or yet to be entered are automatically highlighted in different ways to warn the user and draw his attention to those sections of the report.

Errors of diagnosis were the most common types (IOM, 2006). As pointed out by Berner (Berner, Maisiak, Cobbs, & Taunton, 1999), health care professionals’ diagnostic performance can be strongly influenced by the quality of information the system produces and the type of cases on which the system is used. The accuracy and predictive power of the classifiers derived from data depends on the quality of the data. Information systems should enable the capturing of more complete, accurate, specific and timely medical information. Current reporting methods are insufficient to serve robust data collection for building DDSS because of equivocal abbreviations, a large vocabulary, ungrammatical writing styles, many different codes and complex medical terms, and furthermore they are incomplete since details are assumed to be *common knowledge* and left out (Taira et al., 2001). Thus, decisions upon medical reports are prone to *medical errors* that cause many avoidable deaths. Moreover, *lack of quick dissemination of medical reports, suboptimal report quality and accuracy, and the unsuitability of report information for quality improvement, research and decision supporting* are some of the shortcomings of the conventional reporting. This, as a result, requires additional and in general tedious preprocessing steps to prepare the data for further analysis and use, as in the case of *diagnostic decision support systems* (DDSSs) and *research*. New methods of generating medical reports are required to avoid errors, decrease variations, enable research, support decisions and provide high quality health services. Within this context, the proposed SISDS methodology, which aims to remove the deficiencies of existing methods, and introduces and promises new advantages, emerges as a viable candidate. An advantage that the SISDS methodology puts forward is to ease the data entry process and to demonstrate how it is important to keep and use the knowledge created by experts while they are doing their routine jobs. The building of an accurate DDSS with the most recent data generated by SISDS can be processed with ease and the stored data are easy-to-use promptly to construct DSSs without time consuming preprocessing steps thanks to the collected data in accordance with the features of SISDS mentioned in Chapter 3. How to build DDSS is mentioned in Chapter 5: it presents a proof-of-concept that similar studies can be conducted and DDSSs can be developed rapidly without extensive computer knowledge for other (medical) domains and other ICD-10 codes by incorporating SISDS with off-the-shelf machine learning solutions embedded into the methodology.

## 7.1 Limitations and Further Study

Common language is the foundation of communication, learning, and understanding. Shared concepts and standard definitions are necessary foundations for the field of patient safety, whether for research or for operations of healthcare professionals (MEDSTAT, 2002). Differences in definitions can make inferences across studies impossible, and can make communication across operating departments difficult (MEDSTAT, 2002). Within this context, an effective data collection and reporting system in which well formed domain sets are used is a key element to success. The proposed system in this study should be evaluated with other domains within the same department, radiology or within the other medical branches, beginning with pathology. In this study we chose the field of radiology and a sample esophagus report structure (Appendix A) was constructed by radiology experts from several hospitals using our web-based prototype. The esophagus report structure was prepared by consulting 12 radiologists working in six different hospitals, five of whom are the head of their departments. Despite the fact that the essential part of the report is based on Weissleder's book (Weissleder et al., 2003), in which a comprehensive study of esophagus report is included as a textbook, the experts had different insights about the details of the report and hence reaching a consensus turned out to be a non-trivial task. There is a lack of standards and a lack of consensus on proposed standards in medicine. The standard coding systems upon which professionals or institutions compromised are very limited such as ICD-10, SNOMED and HL7. Thus, the coding systems in terms of the medical terms used in some applications didn't gained widespread acceptance by other professionals or institutions. Without agreed upon standard coding system, healthcare professionals inclined to generate medical reports in free text form to be more flexible and to establish an unequivocal communication. Designing new domain sets for specific areas should be carried out by international and national organization as well as by the leadership of the Health Ministry to provide a consensus among institutions and professionals.

There are barriers for the acceptance of a new method to be integrated into a complex organizational environment such as hospital information systems (HIS), laboratory systems (ex. radiology information system (RIS)), or a part of Picture Archiving and Communication Systems (PACS). To test the SISDS methodology, all personal information relating to patients (date of birth, name, surname etc.) was loaded into the database previously as to imitate SISDS is integrated into HIS and orders by physicians and personal information of patients are drawn from the HIS automatically. Radiologists were just concerned about

their medical reporting process while examining images or patients to generate reports. They weren't expected to enter personal information of patients as in the case of real working conditions. The established DDSS in this study includes very limited number of ICD-10 codes such as K21.9, K22.4 and K44.9 depending on very limited number of instances, 1240. If the process of knowledge-base construction is highly dependent on a single individual or sample data, or carried out only at a single institution, then the survival of that system over time is in jeopardy (D. L. Hunt et al., 1998). Future work should concentrate on a wide-scale deployment of the system integrated into an organizational environment, and development and integration of a comprehensive medical decision support system based on well-rounded collected data in terms of agreed upon standard domain sets.

In the SISDS methodology, users that have to return to the computer screen while generating reports are faced with a look-away problem, which is caused by tasks other than examining patients or images, in case of choosing a medical finding or entering a value in a specified section in a computer application. Look-away problem is reduced by SISDS methodology by which most of the section of medical reports are generated by the system, but not removed completely. Look-away problem is completely removed in the TA approach in which medical reports are stored as speeches and not transformed into a machine readable format. Although look-away problem is better handled in the SISDS methodology, in which most of the information are structured and predefined, and not needed to be checked whether it is correctly written, than some other most common approaches such as DBSR, in which users that have to check what is dictated and correct mistakes while generating reports are faced with a look-away problem. We aim to integrate a speech interface into the SISDS to settle the look-away problem and to obtain better results without using keyboard and looking at monitor. Next study upon this study should include a speech interface modality (SIM) which is integrated into the SISDS methodology. A bilateral interaction should be aimed to perform with the SIM to remove look-away problem during examination as health professionals are to be guided by computers through medical reporting (text-to-speech) and to be able to generate their reports by entering data with their voices (speech-to-text) via a headphone attached to a microphone without the need to look at monitor and return computer to record results. Moreover, users should activate a computer to examine and record specific data entries in a report. Bidirectional intelligent interactivity should be provided with speech to enable hands-free and eyes-free collection of data in real-time by the help of the advantages that the SISDS methodology presents.

In the case of a DDSS, the crucial question is whether a DDS system could contribute to

diagnostic accuracy, and whether the physician will actually accept the diagnostic abilities of the system. Many physicians are concerned that their role will be diminished and that they may become less valuable in medicine if widespread mandatory guideline and protocol use is instituted (Tierney, Overhage, & McDonald, 1996) as they most probably see medicine as an art. While using or building DSS, we should keep in mind that computers can just support doctors in their diagnosing process. Doctors can never be replaced with computers. The goal of decision support is to supply the best recommendation under all circumstances (Klose & Bottcher, 2002). The final decision to decide on a diagnosis belongs to physicians even if systems offer one or more diagnoses. To ensure expert autonomy, an expert can deviate from the recommendations at any time as is in SISDS. On the other hand, Kassirer (1994) concerns that DDS systems are unlikely to be very useful to physicians: it is possible that non-expert professionals will be unable to distinguish useful from misleading information and will possibly reject some correct diagnoses as well as accept the wrong diagnoses. But, sure that, in many perspectives, DDSSs are indispensable and they are needed mainly due to the multitude of variables involved and highly complex relations between them beyond the understanding of human being, although, there is still a risk for a very limited number of non-expert professionals to be misled in some cases.

Acceptance of a system will not be guaranteed even if a system performs as intended. Sociologic, cultural, and financial issues have as much to do with the success or failure of a system as do technological aspects (D. E Forsythe & Miller, 1992). We acknowledge that there are barriers for the acceptance of a new method to be integrated into a complex organizational environment such as hospital information systems (HIS), laboratory systems, or a part of Picture Archiving and Communication Systems (PACS). The adoption of standardized documentation techniques that reduce medical errors and benefit a system may require some policies of either governments or institutions, and may require incentives such as a better diagnostic performance, gaining time, extra payment or benefits to induce professionals to switch from traditional information capture methods to methods that are more interoperable, economic, and provide a basis for better care such as the one we propose in this study.



## REFERENCES

- Andrade, P. J. (1999). Specialized computer support systems for medical diagnosis. relationship with the bayes' theorem and with logical diagnostic thinking. *Arq Bras Cardiol*, 73, 6, 537–552.
- Ash, J., Berg, M., & Coiera, E. (2004). Some unintended consequences of information technology in health care: the nature of patient care information system-related errors. *J Am Med Inform Assoc*, 11, 4, 104–112.
- Babylon. (2000). *Babylon english english dictionary*. Available from [http://www.babylon.com/definition/Boolean\\_algebra/English](http://www.babylon.com/definition/Boolean_algebra/English) ([Online; accessed 22-July-2009])
- Bell, D., & Greenes, R. (1994). Evaluation of ultrastar: Performance of a collaborative structured data entry system. *JAMIA Symposium Supplement*, 216–222.
- Bell, D. S., Greenes, R. A., & Doubilet, P. (1992). Form-based clinical input from a structured vocabulary: initial application in ultrasound reporting. *Proc Annu Symp Comput Appl Med Care*, 789–790.
- Berg, M. (1996). Practices of reading and writing: the constitutive role of the patient record in medical work. *Sociol Health Illn*, 18, 1, 499–524.
- Berner, E. S. (1999). Ds and safety of clinical environments. *Springer-Verlag*.
- Berner, E. S., Maisiak, R. S., Cobbs, C. G., & Taunton, O. D. (1999). Effects of a decision support system on physicians' diagnostic performance. *J Am Med Inform Assoc.*, 6, 5, 420–427.
- Chow, S. C. (2003). *Encyclopedia of biopharmaceutical statistics (2nd ed.)*. Mosby.
- CIHI. (2005). *Medication incident reporting and prevention system: Environmental scan*.

- Available from [http://www.secure.cihi.ca/cihiweb/downloads/CIMIRPS\\_Environment\\_Scan\\_FINAL1.pdf](http://www.secure.cihi.ca/cihiweb/downloads/CIMIRPS_Environment_Scan_FINAL1.pdf) ([Online; accessed 22-November-2009])
- Cimino, J. J., & Patel, V. L. (2001). Studying the human-computer-terminology interface. *J Am Med Inform Assoc*, 8, 1, 163–173.
- Clinger, N., Hunter, T., & Hillman, B. (1998). Radiology reporting: attitudes of referring physicians. *Radiology*, 163, 3, 825–826.
- Corpo, U. D. (2005). How to prepare a questionnaire or a form. *Proceedings of The 8th Biennial European Meeting of Society for Scientific Exploration*, 2, 64–68.
- Cunningham, S. J., & Denize, P. (1994). A tool for model generation and knowledge acquisition. *Dept. of Computer Science University of Waikato*.
- Dacher, J., & Lechevallier, J. (1999). The exam request seen by the radiologist, the report seen by the clinician. *J Radiology*, 80, 8, 166.
- D. E Forsythe, J. A. O., B. G Buchanan, & Miller, R. A. (1992). Expanding the concept of medical information: an observational study of physicians' information needs. *Comput Biomed Res*, 25, 1, 181–200.
- Delaney, B. C., Fitzmaurice, D. A., Riaz, A., & Hobbs, F. D. R. (1999). 'can computerised dss deliver improved quality in primary care? *BMC*, 319(7220), 1.
- DynamicChiropractic. (2004). *Medical errors make the headlines again*. Retrieved September 23, 2007, from <http://www.chiroweb.com/archives/22/20/07.html>.
- Feldman, C. A., & Stevens, D. (1990). Pilot study on the feasibility of a computerized speech recognition charting system. *Community Dent Oral Epidemiol*, 8, 1, 213–215.
- Galloway, A. (1997). *Questionnaire design and analysis*. Available from <http://www.tardis.ed.ac.uk/~kate/qmcweb/qcont.htm> ([Online; accessed 27-December-2008])
- Garrod, S. (1998). How groups co-ordinate their concepts and terminology: implications for medical informatics.methods. *Inf Med*, 37, 1, 471–476.
- Graber, M., Gordon, R., & Franklin, N. (1994). Medical diagnostic decision support systems-past, present and future. *J. Am. Med. Inform Assoc.*, 1, 1, 8–27.

- Graber, M., Gordon, R., & Franklin, N. (2002). Reducing diagnostic errors in medicine: what's the goal? *Acad Med*, *77*, *10*, 981–992.
- Grasso, M. (2003). The long-term adoption of speech recognition in medical application. *Proceedings of the 16th IEEE Symposium on Computer-Based Medical Systems*, 257–262.
- Grzymala, D. M., Grzymala, B., & Grzymala, J. W. (1995). On the usefulness of machine learning approach to knowledge acquisition. *Computational Intelligence*, *11*, *1*, 268–279.
- Gunderman, R., Phillips, M., & Cohen, M. (2001). Improving clinical histories on radiology requisitions. *Academic Radiology*, *8*, *4*, 299–303.
- HealthGrades. (2004). *Quality study. patient safety in american hospitals*. Retrieved March 27, 2006, from [http://www.healthgrades.com/media/english/pdf/HG\\_Patient\\_Safety\\_Study\\_Final.pdf](http://www.healthgrades.com/media/english/pdf/HG_Patient_Safety_Study_Final.pdf).
- Hunt, D. L., Haynes, R. B., Hanna, S., & Smith, K. (1998). 'effects of computer-based clinical decision support systems on physician performance and patient outcomes:a systematic review. *JAMA*, *280*, *1*, 1339–1346.
- Hunt, J. (2002). *Java and object orientation (2nd ed.)*. Springer.
- Iezzoni, L. I. (1999). Clinical decision support systems: Theory and practice. *N Engl J Med*, *341*, *6*, 365–367.
- IOM. (1999, January). *To err is human*. Institute of Medicine of the National Academies Press.
- IOM. (2006, July). *Preventing medication errors: Quality chasm series*. Retrieved April 04, 2007, from <http://www.iom.edu/CMS/3809/22526/35939.aspx>. Institute of Medicine of the National Academies Press.
- Jeans, W. D., Danton, R. M., & Kilburn, A. R. D. (1980). An assessment of a computerized reporting system (sirep). *British Journal of Radiology*, *53*, 421–427.
- Jennings, D., Amabile, T., & Ross, L. (1982). Informal covariation assessments: Data-based versus theory-based judgements. *Cambridge University Press*, 211–230.

- Jost, R. G. (1986). Radiology reporting. *Clinics of North America*, 24, 1, 19–26.
- Kahn, C. (1997). A generalized language for platform independent structured reporting. *Methods Inf Med*, 36, 1, 163–171.
- Kahn, C., Wang, K., & Bell, D. S. (1996). Structured entry of radiology reports using world wide web technology. *RadioGraphics*, 16, 1, 683–691.
- Kassirer, J. P. (1994). A report card on computer-assisted diagnosis: the grade. *C. N Engl J Med*, 330, 1, 1824–1825.
- Klose, K. J., & Bottcher, J. (2002). Activity based costing in radiology. *Radiology*, 42, 1, 369–375.
- Lehmann, H. P., Abbott, P. A., Roderer, N. K., Rodhschild, A., Mandell, S., Ferrer, J. A., et al. (2006). *Aspects of electronic health record system(2nd ed.)*. Springer.
- Lyman, M., Sager, N., Tick, L., & Nhan, N. (1995). Medical language processing: applications to patient data representation and automatic encoding. *Methods Inf Med*, 34, 1, 140–146.
- MEDSTAT. (2002). *Implementation planning study for the integration of medical event reporting input and data structure for reporting to ahrq, cdc, cms, and fda*. Available from <http://www.ahrq.gov/downloads/pub/rfp020015/merip.pdf> ([Online; accessed 22-July-2009])
- Miller, G. (1999). Development of decision support algorithms for intensive care medicine: A new approach combining time series analysis and a knowledge base system with learning and revision. in: G. miller. the magical number seven, plus of minus two: Some limits to our capacity for processing information. *LNCS*, 1701/1999, 698–699.
- Mogensen, V. (1999). Ergonomic inaction: Congress puts oshas ergonomics standard on hold. *Academic Radiology*. Retrieved August 12, 2007, from [http://www.tifaq.org/articles/ergonomic\\_inaction-jan99-vernon\\_mogensen.html](http://www.tifaq.org/articles/ergonomic_inaction-jan99-vernon_mogensen.html).
- Morris, A., & Gardner, R. (1992). Computer applications. in: Hall j, schmidt g, wood l (eds):principles of critical care. *McGraw-Hill, New York*, 500–514.
- Morris, A. H. (2002). Quality and safety in health care. *BMC*, 11, 1, 69–75.

- Naik, S., Hanbidge, A., & Wilson, S. (2001). Radiology reports: examining radiologist and clinician preferences regarding style and content. *American Journal of Roentgenology*, *176*, *3*, 591–592.
- NCVHS. (2005). *Measuring health care quality: Obstacles and opportunities*. Available from <http://www.ncvhs.hhs.gov/040531rp.pdf> ([Online; accessed 23-April-2005])
- Noë, A., Pessoa, L., & Thompson, E. (2000). Beyond the grand illusion: What change blindness really teaches us about vision. *Visual Cognition*, *7*, *2*, 93–106.
- Nosek, R. (2006). *Standardizing medication error event reporting in the u.s.* Retrieved January 27, 2006, from <http://www.ahrq.gov/downloads/pub/advances/vol4/Nosek.pdf>. Department of Defense, USA.
- O'Brien, D. (1997). *Questionnaire design*. Available from [http://www.cc.gatech.edu/classes/cs6751\\_97\\_winter/Topics/quest-design](http://www.cc.gatech.edu/classes/cs6751_97_winter/Topics/quest-design) ([Online; accessed 27-December-2008])
- O'Leary, D. E. (1999). Models of consensus for knowledge acquisition. *Proceedings of the 32nd Hawaii International Conference on System Sciences*.
- Patel, V., & Kaufman, D. (1998). Medical informatics and the science of cognition. *J Am Med Inform Assoc*, *5*, *1*, 493–502.
- Patel, V., & Kushniruk, A. (1998). Understanding, navigating and communicating knowledge: issues and challenges. *Inf Med*, *37*, *1*, 460–470.
- Payne, T. H. (2000). Computer decision support systems. *Chest*, *118*, *1*, 47–52.
- Ricky, K., Taira, S., & G Soderland, M. J. R. (2001). Automatic structuring of radiology free-text reports. *Radiology*, *21*, *1*, 237–245.
- Shiffman, S., W.M Detmer, C. L., & Fagan, L. (1995). A continuous-speech interface to a decision-support system: I. techniques to accomodate for misrecognized input. *Community Dent Oral Epidemiol*, *2*, *1*, 36–45.
- Sim, I., & Rennels, G. (1995). A trial bank model for the publication of clinical trials. *Proc Annu Symp Comput Appl Med Care*, *11*, *5*, 863–867.

- Sinha, U. (2000). Interactive software for generation and visualization of structured findings in radiology reports. *Ac. Journal of Radiology*, *175*, *1*, 609–612.
- Sistrom, C. L. (2005). Conceptual approach for the design of radiology reporting interfaces: The talking template. *Journal of Digital Imaging*, *18*, *3*, 176–187. Retrieved January 01, 2006, from <http://www.springerlink.com/content/g47517686m1n582t/>.
- Sistrom, C. L., & Langlotz, C. (2005a). A framework for improving radiology reporting. *J Am Coll Radiol*, *2*, *1*, 61–67.
- Sistrom, C. L., & Langlotz, C. P. (2005b). A framework for improving radiology reporting. *J Am Coll Radiol*, *2*, *1*, 61–67.
- Smith, N. T., Brian, R. A., Pettus, D. C., Jones, B., & Sarnat, M. L. Q. L. (1990). Recognition accuracy with a voice-recognition system designed for anesthesia record keeping. *J Clin Monit*, *6*, *4*, 299–306.
- Smith, N. T., Brian, R. A., Pettus, D. C., Jones, B., & Sarnat, M. L. Q. L. (2001). Computer-based speech recognition as an alternative to medical transcription. *Am Med Inform Assoc*, *8*, *1*, 101–102.
- Sorenson, J., Grove, H., & Selto, F. (1982). Detecting management fraud: An empirical approach. *Symposium on Auditing Research, University of Illinois*, 72–116.
- Svanfeldt, G. (n.d.). A speech interface demonstrator for pre-operative planning within orthopaedic surgery. master degree project in speech communication. Retrieved June 03, 2006, from <http://www.speech.kth.se/prod/publications/files/1659.pdf>.
- Taira, R. K., Soderland, S. G., & Jakobovits, R. M. (2001). Automatic structuring of radiology free-text reports. *Radiographics*, *21*, *1*, 237–245.
- Tierney, W. M., Overhage, J. M., & McDonald, C. J. (1996). Computerizing guidelines: factors for success. in: Cimino j, ed. proceedings of 1996 amia annual fall symposium (formerly scamc). *Washington: Hanley and Belfus*, 459–462.
- TransTimeMed. (2002). *Speech dictation with medical transcription*. Retrieved March 27, 2006, from <http://http://www.transtimemed.com/mnTrends-VoiceRecog.html>.
- Waegemann, C. P., Tessier, C., Barbash, A., Blumenfeld, B. H., Borden, J., Brinson, R. M.,

- et al. (2002). *Healthcare documentation: A report on information capture and report generation*. Retrieved October 13, 2007, from <http://www.medrecinst.com/files/finalreport.pdf>.
- Wang, C., & Kahn, C. E. (2000). Potential use of extensible markup language for radiology reporting. *RadioGraphic*, 20, 1, 287–293.
- Weissleder, R., Jones, S. E., Wittenberg, J., Harisinghani, M. G., & Harisinghani, M. G. (2003). *Primer of diagnostic imaging (3rd ed.)*. Marcel Dekker, inc.
- WHO. (2005). *Project to develop the international patient safety event taxonomy: Updated review of the literature 2003-2005*. Available from [http://www.who.int/patientsafety/taxonomy/IPSET\\_Sept05\\_FINAL.pdf](http://www.who.int/patientsafety/taxonomy/IPSET_Sept05_FINAL.pdf) ([Online; accessed 23-January-2009])
- WHO. (2007). *International statistical classification of diseases and related health problems, 10th revision, version for 2007*. Available from <http://apps.who.int/classifications/apps/icd/icd10online/?gk20.htm+k21> ([Online; accessed 21-January-2008])
- Wikipedia. (1996a). *Boosting — Wikipedia, the free encyclopedia*. Available from <http://en.wikipedia.org/wiki/Boosting> ([Online; accessed 17-July-2009])
- Wikipedia. (1996b). *Bootstrap aggregating — Wikipedia, the free encyclopedia*. Available from <http://en.wikipedia.org/wiki/Boosting> ([Online; accessed 17-July-2009])
- Wikipedia. (2001). *Comma-separated values — Wikipedia, the free encyclopedia*. Available from [http://en.wikipedia.org/wiki/Comma-separated\\_values](http://en.wikipedia.org/wiki/Comma-separated_values) ([Online; accessed 2-January-2009])
- Wikipedia. (2003). *Snomed ct — Wikipedia, the free encyclopedia*. Available from [http://en.wikipedia.org/wiki/SNOMED\\_CT](http://en.wikipedia.org/wiki/SNOMED_CT) ([Online; accessed 2-January-2010])
- Wikipedia. (2004a). *Ajax programming — Wikipedia, the free encyclopedia*. Available from [http://en.wikipedia.org/wiki/Ajax\\_\(programming\)](http://en.wikipedia.org/wiki/Ajax_(programming)) ([Online; accessed 22-July-2009])
- Wikipedia. (2004b). *Picture archiving and communication system — Wikipedia, the free*

- encyclopedia*. Available from [http://en.wikipedia.org/wiki/Picture\\_archiving\\_and\\_communication\\_system](http://en.wikipedia.org/wiki/Picture_archiving_and_communication_system) ([Online; accessed 04-January-2010])
- Wikipedia. (2005a). *Backus-aur form* — *Wikipedia, the free encyclopedia*. Available from [http://en.wikipedia.org/wiki/BackusE28093Naur\\_Form](http://en.wikipedia.org/wiki/BackusE28093Naur_Form) ([Online; accessed 22-November-2009])
- Wikipedia. (2005b). *Electronic health record* — *Wikipedia, the free encyclopedia*. Available from [http://en.wikipedia.org/wiki/Electronic\\_health\\_record](http://en.wikipedia.org/wiki/Electronic_health_record) ([Online; accessed 05-January-2010])
- Wikipedia. (2005c). *Icd-10* — *Wikipedia, the free encyclopedia*. Available from <http://en.wikipedia.org/wiki/ICD-10> ([Online; accessed 05-January-2010])
- Wikipedia. (2005d). *Model view controller* — *Wikipedia, the free encyclopedia*. Available from <http://en.wikipedia.org/wiki/Model-view-controller> ([Online; accessed 05-January-2010])
- Wikipedia. (2005e). *Natural language processing* — *Wikipedia, the free encyclopedia*. Available from [http://en.wikipedia.org/wiki/Natural\\_language\\_processing](http://en.wikipedia.org/wiki/Natural_language_processing) ([Online; accessed 05-January-2010])
- Wilson, D., McArtney, R., & Newcombe, G. (1998). Medication errors in paediatric practice: Insights from a continuous quality improvement approach. *Eur J Pediatr*, *157*, *1*, 769–774.
- Witten, I. H., & Frank, E. (1997). *Data mining, secon edition*. Elsevier.
- Zafar, A., Overhage, J. M., Clement, J., & McDonald, C. J. (1999). Continuous speech recognition for clinicians. *Am Med Inform Assoc*, *6*, *3*, 195–204.



## Appendix A

# RADIOLOGY ESOPHAGUS REPORT FORMAT APPLIED TO THE SISDS METHODOLOGY

1. Hastanın pozisyonu nasıldır? *[position/yatarak prone oblik, erekt sol oblik, erekt sol lateral, erekt sağ lateral, semierekt, supin, trandelenburg, yatarak ve ayakta: erekt sol lateral]*dir.

How is the position of the patient? = *[position/prone oblique, erect left oblique, erect left lateral, erect right lateral , semierect, supin, trandelenburg, lie-down and erect]*.

Hastanın pozisyonu *[position]*dir.

The position of the patient is *[position/prone oblique, erect left oblique, erect left lateral, erect right lateral , semierect, supin, trandelenburg, lie-down and erect]*.

2. Oral yoldan kullanılan kontrast madde nedir? = *[contrast/baryum maddesi, suda erir kontrast madde, damar içi kontrast madde: baryum maddesi]*dir.

What is the contrast media used in oral way? = *[contrast/barium, contrast media dissolving in water, contrast media through vein]*.

Oral yoldan kullanılan kontrast madde *[contrast]*dir.

The contrast media used in oral way is *[contrast/barium, contrast media dissolving in water, contrast media through vein]*.

3. Kontrast maddenin lümen dışına kaçıışı var mıdır? = *[extravasating/yoktur, vardır: yoktur; normal=yoktur]*

Is there leakage of contrast media out of the lumen? = *[extravasating/There isn't, There is]*.

Kontrast maddenin lümen dışına kaçıışı *[extravasating]*.

*[extravasating/There isn't, There is]* leakage of contrast media out of the lumen.

**Condition 1:** *[extravasating]* == “vardır”

- Kaçağın olduğu özafagus bölgesi neresidir? = *[section/proksimal 1/3 özafagus, orta 1/3 özafagus, distal 1/3 özafagus, tüm özafagus: proksimal 1/3 özafagus; normal=yok]tur.*

Which section is the section of the extravasating? = *[section/1/3 esophagus, middle 1/3 esophagus, distal 1/3 esophagus, whole esophagus]*.

Kaçağın olduğu özafagus bölgesi *[section]tur.*

The section of the extravasating is *[section/1/3 esophagus, middle 1/3 esophagus, distal 1/3 esophagus, whole esophagus]*.

4. Kontrast maddenin özofagustan mideye geçişi nasıldır? = *[transition/beklemeden normal hızla olmuştur, bekleyerek olmuştur, bekleyerek belirli seviye oluştuktan sonra olmuştur, olmamıştır: beklemeden normal hızla olmuştur; normal=beklemeden normal hızla olmuştur]*.

How is the transition of the contrast media from the esophagus to stomach? = *[transition/as normal without delay, delayed transition, happens after a level occurred and with delay, doesn't happen]*.

Kontrast maddenin özofagustan mideye geçişi *[transition]*.

The transition of the contrast media from the esophagus to stomach is *[transition/as normal without delay, delayed transition, happens after a level occurred and with delay, doesn't happen]*.

**Condition 1:** *[transition]* == “bekleyerek belirli seviye oluştuktan sonra olmuştur”

- Görülen seviye nasıldır? = *[level/1/3 üst özafagusta, 1/3 orta özafagusta, 1/3 alt özafagusta, tüm özafagus boyunca: 1/3 üst özafagusta; normal=yok]*dir.

What is the site of the level? = *[level/1/3 upper esophagus, 1/3 lower esophagus, whole esophagus]*.

Görülen seviye *[level]*tadır.

The site of the level is *[level/1/3 upper esophagus, 1/3 middle esophagus, 1/3 lower esophagus, whole esophagus]*.

5. Kontast madde geçişi sırasında görülen peristaltik dalganın özelliği nedir? = *[peristalsis\_wave/primer, primer seconder, primer seconder tersiyer, belirgin olarak izlenmemiş, azalmış, tersiyer: primer; normal=primer]*dir.

What is the feature of the peristalsis wave during the transition of the contrast media? = *[peristalsis\_wave/primary, primer seconder, primer secondary tertiary, not observed specifically, decreased, tertiary]*.

Kontast madde geçişi sırasında görülen peristaltik dalganın özelliği *[peristalsis\_wave]*dir.

The feature of the peristalsis wave during the transition of the contrast media is *[peristalsis\_wave/primary, primer secondary, primer seconder tertiary, not observed specifically, decreased, tertiary]*.

**Condition 1:** *[peristalsis\_wave]* == “primer seconder tersiyer” || *[peristalsis\_wave]* == “tersiyer”

- Tersiyer peristaltik dalgaların saptandığı özafagus seviyesi nedir? = *[level/proksimal 1/3 özafagusta, orta 1/3 özafagusta, distal 1/3 özafagusta, tüm özafagus bölümlerinde diffüz spazm (tirbüşon özafagus) görüntüsünde, orta distal: proksimal 1/3 özafagusta; normal=yok]*dir.

In which section peristalsis waves are observed? = *[level/1/3 esophagus, middle 1/3 esophagus, distal 1/3 esophagus, as a shape of diffusesive spasm (corkscrew esophagus) whole esophagus, middle distal]*.

Tersiyer peristaltik dalgaların saptandığı özafagus seviyesi *[level]*dir.

The section in which peristalsis waves are observed is *[level/1/3 esophagus, middle 1/3 esophagus, distal 1/3 esophagus, as a shape of diffuse spasm (corkscrew esophagus) whole esophagus, middle distal]*.

**Condition 2:** *[peristalsis\_wave]* == “belirgin olarak izlenmemiş”

- Peristaltik dalganın belirgin olarak izlenmediği bölge neresidir? = *[section/proksimal 1/3 özafagus, orta 1/3 özafagus, distal 1/3 özafagus, tüm özafagus: proksimal 1/3 özafagus; normal=yok]*tur.

In which section peristalsis wave is not observed specifically? = *[section/proximal 1/3 esophagus, middle 1/3 esophagus, distal 1/3 esophagus, whole esophagus]*.

Peristaltik dalganın belirgin olarak izlenmediği bölge *[section]*tur.

*[section/proximal 1/3 esophagus, middle 1/3 esophagus, distal 1/3 esophagus, whole]* is the section in which peristalsis wave not observed specifically.

6. Kontrast madde geçişi sırasında özafagusta belirgin genişleme göstermeyen, dar (13 mm den daha az) bölüm var mı? = *[narrowness/yok, var: yok; normal=yok]*.

Is there any narrowness without a clear expansion in the esophagus during the transition of the contrast media? = *[narrowness/There isn't, There is]*.

Kontrast madde geçişi sırasında özafagusta belirgin genişleme göstermeyen, dar (13 mm den daha az) bölüm *[narrowness]*.

*[narrowness/There isn't, There is]* narrowness without a clear expansion in the esophagus during the transition of the contrast media.

**Condition 1:** *[narrowness]* == “var”

- Özafagusun belirgin genişleme olmayan bölgesi hangi seviyededir? = *[section/proksimal 1/3 özafagus, orta 1/3 özafagus, distal 1/3 özafagus, tüm özafagus, proksimal + orta 1/3 özafagus, proksimal + distal 1/3 özafagus, orta + distal 1/3 özafagus: proksimal 1/3 özafagus; normal=yok]*tur.

In which section there isn't a clear expansion during the transition of the contrast media? = *[section/proximal 1/3 esophagus, middle 1/3 esophagus, distal 1/3 esophagus, whole esophagus, proximal + middle 1/3 esophagus, proximal + distal 1/3 esophagus, middle + distal 1/3 esophagus]*.

Özafagusun belirgin genişleme olmayan bölgesinin seviyesi *[section]*tur.

The section in which there isn't a clear expansion during the transition of the contrast media is *[section/proximal 1/3 esophagus, middle 1/3 esophagus, distal 1/3 esophagus, whole esophagus, proximal + middle 1/3 esophagus, proximal + distal 1/3 esophagus, middle + distal 1/3 esophagus]*.

**Condition 1:** *[section]* != “ ”

(a) Dar segment uzunluğu ne kadardır? = *[length/length: 2 cm; min=0 cm, max=0 cm]* dir.

What is the length of the narrow segment? = *[length]*.

Dar segment uzunluğu *[length]* dir.

The length of the narrow segment is *[length]*.

**Condition 1:**  $CU([length], 'cm') > 0$

– Dar segmentin yerleşimi nasıldır? = *[settlement/simetrik, asimetrik: simetrik; normal=simetrik]*tir.

what is the site of the narrow segment? = *[settlement/symmetrical, asymmetrical]*.

Dar segmentin yerleşimi *[settlement]*tir.

The site of the narrow segment is *[settlement/symmetrical, asymmetrical]*.

**Condition 1:** *[settlement]* != “”

i. Dar özafagus segmenti nasıldır? = *[segment/düzenli, düzensiz: düzenli; normal=düzenli]*dir.

How is the narrow esophagus segment? = *[segment/regular, irregular]*.

Dar özafagus segmenti *[segment]*dir.

The narrow esophagus segment is *[segment/regular, irregular]*.

**Condition 2:** *[narrowness]* == “yok”

- Özafagusta mukozal rölyef nasıldır? = *[relief/normal, normal değil: normal; normal=normal]*dir.

How is the mucosal relief of the esophagus? = *[relief/normal, not normal]*.

Özafagusta mukozal rölyef *[relief]*dir.

The mucosal relief of the esophagus is *[relief/normal, not normal]*.

**Condition 1:** *[relief]* ==“normal değil”

- (a) Özafagusta normal olmayan rölyef nasıldır? = *[topography/kalınlaşmış mukozal kıvrımlar görünümde, retüküler mukozal patern görünümde, mukozal nodüler görünümde, ince transvers mukozal çizgiler (feline özafagus) görünümde: kalınlaşmış mukozal kıvrımlar görünümde; normal=yok]*dir.

How is the abnormal relief of the esophagus? = *[topography/thickened mucosal folds, reticular mucosal pattern, nodular mucosal pattern , thin transverse mucosal folds(feline özafagus)]*.

Özafagusta normal olmayan rölyef *[topography]*dir.

The abnormal relief of the esophagus is in the shape of *[topography/thickened mucosal folds, reticular mucosal pattern, nodular mucosal pattern , thin transverse mucosal folds(feline özafagus)]*.

**Condition 2:** *[relief]* ==“normal değil”

- (a) Normal olmayan rölyef hangi seviyededir? = *[relief\_level/proksimal 1/3 özafagus, orta 1/3 özafagus, distal 1/3 özafagus, tüm özafagus, proksimal + orta 1/3 özafagus, proksimal + distal 1/3 özafagus, orta + distal 1/3 özafagus: proksimal 1/3 özafagus; normal=yok]*tur.

In which section there is an abnormal relief? = *[relief\_level/proximal 1/3 esophagus, middle 1/3 esophagus, distal 1/3 esophagus,*

*whole esophagus, proximal + middle 1/3 esophagus, proximal + distal 1/3 esophagus, middle + distal 1/3 esophagus*].

Normal olmayan rölyef hangi seviyededir? = *[relief\_level]*tur.

The level of abnormal relief is *[relief\_level/proximal 1/3 esophagus, middle 1/3 esophagus, distal 1/3 esophagus, whole esophagus, proximal + middle 1/3 esophagus, proximal + distal 1/3 esophagus, middle + distal 1/3 esophagus]*.

7. Özafagusta dolum defekti var mıdır? = *[defect/yoktur, vardır: yoktur; normal=yoktur]*.

Is there a filling defect in the esophagus? = *[defect/There isn't, There is]*.

Özafagusta dolum defekti *[defect]*.

*[defect/There isn't, There is]* a filling defect in the esophagus.

**Condition 1:** *[defect]* == “vardır”

• Dolum defekti kaç tanedir? = *[defectNumber/1, 2, 3, multiple: 1; normal=yok]* tanedir.

What is the number of the filling defects? = *[defectNumber/1, 2, 3, multiple]*

Dolum defekti *[defectNumber]* tanedir.

The number of the filling defects is *[defectNumber/1, 2, 3, multiple]*.

**Condition 1:** *[defectNumber] > 0 && [defectNumber] < 4*

(a) İlk dolum defekti hangi seviyededir? = *[level/proksimal 1/3 özafagustur, orta 1/3 özafagustur, distal 1/3 özafagustur, tüm özafagustur, özafagus mide birleşim düzeyidir, özafagusgastrik bileşkedir: proksimal 1/3 özafagustur; normal=yok]*.

What is level of the first filling defect? = *[level/proximal 1/3 esophagus, middle 1/3 esophagus, distal 1/3 esophagus, whole esophagus, level of the esophagogastric junction, esophagogastric junction]*.

İlk dolum defektinin seviyesi *[level]*tur.

The level of the first filling defect is *[level/proximal 1/3 esophagus, middle 1/3 esophagus, distal 1/3 esophagus, whole esophagus, level of the esophagogastric junction, esophagogastric junction]*.

**Condition 1:**  $[level] != ""$

– İlk dolum defekti nasıldır? =  $[defect/düzgün çizgisel yapı, düzensiz polipoid saph, düzensiz polipoid sapsız, düzensiz polipoid ülsere, yılanvari kıvrıntılı dolun, çizgili plaklar, nodüler: düzgün çizgili yapı; normal=yok]$  şeklindedir.

How is the shape of the first filling defect? =  $[defect/regular linear structure, irregular polipoid pedunculated, irregular polipoid without pedunculated, irregular polipoid ulcerated, snakelike curly filled, linear discs, circular noduler]$ .

İlk dolun defektin  $[defect]$  şeklindedir.

The first filling defect is in the shape of  $[defect/regular linear structure, irregular polipoid pedunculated, irregular polipoid without pedunculated, irregular polipoid ulcerated, snakelike curly filled, linear discs, circular noduler]$ .

**Condition 1:**  $[defect] != ""$

i. İlk dolun defektinin boyutu ne kadardır? =  $[size/length: 2.5 cm ; min=0 cm, max=0 cm]$  dir.

What is the size of the first filling defect? =  $[size]$ .

İlk dolun defektinin boyutu ne kadardır  $[size]$  dir.

The size of the first filling defect is  $[size]$ .

**Condition 2:**  $[defectNumber] > 1 \ \&\& \ [defectNumber] < 4$

(a) İkinci dolun defekti hangi seviyededir? =  $[level/proksimal 1/3 özafagustur, orta 1/3 özafagustur, distal 1/3 özafagustur, tüm özafagustur, özafagus mide birleşim düzeyidir, özafagusgastrik bileşkedir: proksimal 1/3 özafagustur; normal=yok]$ .

What is level of the second filling defect? =  $[level/proximal 1/3 esophagus, middle 1/3 esophagus, distal 1/3 esophagus, whole esophagus, level of the esophagogastric junction, esophagogastric junction]$ .

İkinci dolun defektinin seviyesi  $[level]$ .

The level of the second filling defect is  $[level/proximal 1/3 esophagus, middle 1/3 esophagus, distal 1/3 esophagus, whole esophagus, level of the esophagogastric junction, esophagogastric junction]$ .



**Condition 1:** *[level]* != “”

– İkinci dolum defekti nasıldır? = *[defect/düzgün çizgili yapı, düzensiz polipoid saph, düzensiz polipoid sapsız, düzensiz polipoid ülsere, yılanvari kıvrıntılı dolum, çizgili plaklar, nodüler: düzgün çizgili yapı; normal=yok]* şeklindedir.

How is the shape of the second filling defect? = *[defect/regular linear structure, irregular polipoid pedunculated, irregular polipoid without pedunculated, irregular polipoid ulcerated, snakelike curly filled, linear discs, circular noduler]*.

İkinci dolum defektin *[defect]* şeklindedir.

The second filling defect is in the shape of *[defect/regular linear structure, irregular polipoid pedunculated, irregular polipoid without pedunculated, irregular polipoid ulcerated, snakelike curly filled, linear discs, circular noduler]*.

**Condition 1:** *[defect]* != “”

i. İkinci dolum defektinin boyutu ne kadardır? = *[size/length: 2.5 cm ; min=0 cm, max=0 cm]* dir.

What is the size of the second filling defect? = *[size]*.

İkinci dolum defektinin boyutu ne kadardır *[size]* dir.

The size of the second filling defect is *[size]*.

**Condition 3:** *[defectNumber]* > 2 && *[defectNumber]* < 4

(a) Üçüncü dolum defekti hangi seviyededir? = *[level/proksimal 1/3 özafagustur, orta 1/3 özafagustur, distal 1/3 özafagustur, tüm özafagustur, özafagus mide birleşim düzeyidir, özafagusgastrik bileşkedir: proksimal 1/3 özafagustur; normal=yok]*.

What is level of the third filling defect? = *[level/proximal 1/3 esophagus, middle 1/3 esophagus, distal 1/3 esophagus, whole esophagus, level of the esophagogastric junction, esophagogastric junction]*.

Üçüncü dolum defektinin seviyesi *[level]*tur.

The level of the third filling defect is *[level/proximal 1/3 esophagus, middle 1/3 esophagus, distal 1/3 esophagus, whole esophagus, level of the esophagogastric junction, esophagogastric junction]*.

**Condition 1:** *[level] != ""*

– Üçüncü dolum defekti nasıldır? = *[defect/düzgün çizgili yapı, düzensiz polipoid saplı, düzensiz polipoid sapsız, düzensiz polipoid ülsere, yılanvari kıvrıntılı dolum, çizgili plaklar, nodüler: düzgün çizgili yapı; normal=yok]* şeklindedir.

How is the shape of the third filling defect? = *[defect/regular linear structure, irregular polipoid pedunculated, irregular polipoid without pedunculated, irregular polipoid ulcerated, snakelike curly filled, linear discs, circular noduler]*.

Üçüncü dolum defektin *[defect]* şeklindedir.

The third filling defect is in the shape of *[defect/regular linear structure, irregular polipoid pedunculated, irregular polipoid without pedunculated, irregular polipoid ulcerated, snakelike curly filled, linear discs, circular noduler]*.

**Condition 1:** *[defect] != ""*

i. En büyük dolum defektinin boyutu ne kadardır? = *[size/length: 2.5 cm ; min=0 cm, max=0 cm]*dir.

What is the size of largest the filling defect? = *[size]*.

En büyük dolum defektinin boyutu *[size]* dir.

The size of the largest filling defect is *[size]*.

**Condition 4:** *[defectNumber] == "multiple"*

(a) En küçük dolum defekti hangi seviyededir? = *[level/proksimal 1/3 özafagustur, orta 1/3 özafagustur, distal 1/3 özafagustur, tüm özafagustur, özafagus mide birleşim düzeyidir, özafagusgastrik bileşkedir: proksimal 1/3 özafagustur; normal=yok]*.

What is level of smallest filling defect? = *[level/proximal 1/3 esophagus, middle 1/3 esophagus, distal 1/3 esophagus, whole esophagus, level of the esophagogastric junction, esophagogastric junction]*.

En küçük dolum defektinin seviyesi *[level]*tur.

The level of the smallest filling defect is *[level/proximal 1/3 esophagus, middle 1/3 esophagus, distal 1/3 esophagus, whole esophagus, level of the esophagogastric junction, esophagogastric junction]*.

**Condition 1:** *[level]* != “”

– En küçük dolum defekti nasıldır? = *[defect/düzgün çizgili yapı, düzensiz polipoid sapsız, düzensiz polipoid sapsız, düzensiz polipoid ülsere, yılanvari kıvrıntılı dolum, çizgili plaklar, nodüler: düzgün çizgili yapı; normal=yok]* şeklindedir.

How is the shape of the smallest filling defect? = *[defect/regular linear structure, irregular polipoid pedunculated, irregular polipoid without pedunculated, irregular polipoid ulcerated, snakelike curly filled, linear discs, circular noduler]*.

En küçük dolum defektin *[defect]* şeklindedir.

The smallest filling defect is in the shape of *[defect/regular linear structure, irregular polipoid pedunculated, irregular polipoid without pedunculated, irregular polipoid ulcerated, snakelike curly filled, linear discs, circular noduler]*.

**Condition 1:** *[defect]* != “”

i. En küçük dolum defektinin boyutu ne kadardır? = *[size/length: 2.5 cm ; min=0 cm, max=0 cm]* dir.

What is the size of the smallest filling defect? = *[size]*.

En küçük dolum defektinin boyutu *[size]* dir.

The size of the smallest filling defect is *[size]*.

**Condition 5:** *[defectNumber]* == “multiple”

(a) En büyük dolum defekti hangi seviyededir? = *[level/proksimal 1/3 özafagustur, orta 1/3 özafagustur, distal 1/3 özafagustur, tüm özafagustur, özafagus mide birleşim düzeyidir, özafagusgastrik bileşkedir: proksimal 1/3 özafagustur; normal=yok]*.

What is level of the largest filling defect? = *[level/proximal 1/3 esophagus, middle 1/3 esophagus, distal 1/3 esophagus, whole esophagus, level of the esophagogastric junction, esophagogastric junction]*.

En büyük dolum defektinin seviyesi *[level]*tur.

The level of the largest filling defect is *[level/proximal 1/3 esophagus, middle 1/3 esophagus, distal 1/3 esophagus, whole esophagus, level of the esophagogastric junction, esophagogastric junction]*.

**Condition 1:** *[level] != ""*

– En büyük dolum defekti nasıldır? = *[defect/düzgün çizgili yapı, düzensiz polipoid sapsız, düzensiz polipoid sapsız, düzensiz polipoid ülsere, yılanvari kıvrıntılı dolum, çizgili plaklar, nodüler: düzgün çizgili yapı; normal=yok]* şeklindedir.

How is the shape of the largest filling defect? = *[defect/regular linear structure, irregular polipoid pedunculated, irregular polipoid without pedunculated, irregular polipoid ulcerated, snakelike curly filled, linear discs, circular noduler]*.

En büyük dolum defektin *[defect]* şeklindedir.

The largest filling defect is in the shape of *[defect/regular linear structure, irregular polipoid pedunculated, irregular polipoid without pedunculated, irregular polipoid ulcerated, snakelike curly filled, linear discs, circular noduler]*.

**Condition 1:** *[defect] != ""*

i. En büyük dolum defektinin boyutu ne kadardır? = *[size/length: 2.5 cm ; min=0 cm, max=0 cm]* dir.

What is the size of largest the filling defect? = *[size]* .

En büyük dolum defektinin boyutu *[size]* dir.

The size of the largest filling defect is *[size]* .

8. Özafagus mukozasında ülsere lezyon var mıdır? = *[ulcero\_lezyon/yoktur, vardır: yoktur; normal=yoktur]*.

Is there ulcerated lesion in the mucosa of the esophagus? = *[ulcero\_lezyon/There isn't, There is]*.

Özafagus mukozasında ülsere lezyon *[ulcero\_lezyon]*.

*[ulcero\_lezyon/There isn't, There is]* ulcerated lesion in the mucosa of the esophagus.

**Condition 1:** *[ulcero\_lezyon] == "vardır"*

• Ülsere lezyonun kaç tanedir? = *[lesionNumber/1, 2, 3, multiple: 1; normal=yok]* tanedir.

How many ulcerated lesions are there? = *[lesionNumber/1, 2, 3, multiple]*.

Ülsere lezyon *[lesionNumber]* tanedir.

The number of the ulcerated lesions is  $[lesionNumber/1, 2, 3, multiple]$ .

**Condition 1:**  $[lesionNumber] > 0 \ \&\& \ [lesionNumber] < 4$

(a) İlk ülsere lezyonun boyutu ne kadardır? =  $[size/length: 2.5 \text{ cm} ; min=0 \text{ cm}, max=0 \text{ cm}]$  dir.

What is the size of the first ulcerated lesion? =  $[size]$ .

İlk ülsere lezyonun boyutu  $[size]$  dir.

The size of the first ulcerated lesion is  $[size]$ .

**Condition 1:**  $CU([size], 'cm') > 0$

– İlk ülsere lezyonun şekli nasıldır? =  $[shape\_UlcerLesion/küçük yüzeysel ülserler, dev elmas (diamond shape), düzensiz sınırlı: küçük yüzeysel ülserler; normal=yok]$  şeklindedir.

what is the shape of the first ulcerated lesion? =  $[shape\_UlcerLesion/small superficial ulcers, giant diamond , irregular restrictive]$ .

İlk ülsere lezyonun  $[shape\_UlcerLesion]$  şeklindedir.

The shape of the first ulcerated lesion is  $[shape\_UlcerLesion/small superficial ulcers, giant diamond, irregular restrictive]$ .

**Condition 2:**  $[lesionNumber] > 1 \ \&\& \ [lesionNumber] < 4$

(a) İkinci ülsere lezyonun boyutu ne kadardır? =  $[size/length: 2.5 \text{ cm} ; min=0 \text{ cm}, max=0 \text{ cm}]$  dir.

What is the size of the second ulcerated lesion? =  $[size]$ .

İkinci ülsere lezyonun boyutu  $[size]$  dir.

The size of the second ulcerated lesion is  $[size]$ .

**Condition 1:**  $CU([size], 'cm') > 0$

– İkinci ülsere lezyonun şekli nasıldır? =  $[shape\_UlcerLesion/küçük yüzeysel ülserler, dev elmas (diomond shape), düzensiz sınırlı: küçük yüzeysel ülserler; normal=yok]$  şeklindedir.

what is the shape of the second ulcerated lesion? = *[shape\_UlceroLesion/small superficial ulcers, giant diamond ulcer, irregular restrictive]*.

İkinci ülsere lezyonun *[shape\_UlceroLesion]* şeklindedir.

The shape of the second ulcerated lesion is *[shape\_UlceroLesion/small superficial ulcers, giant diamond ulcer, irregular restrictive]*.

**Condition 3:** *[lesionNumber] > 2 && [lesionNumber] < 4*

(a) Üçüncü ülsere lezyonun boyutu ne kadardır? = *[size/length: 2.5 cm ; min=0 cm, max=0 cm]* dir.

What is the size of the third ulcerated lesion? = *[size]*.

Üçüncü ülsere lezyonun boyutu *[size]* dir.

The size of the third ulcerated lesion is *[size]*.

**Condition 1:** *CU([size], 'cm') > 0*

– Üçüncü ülsere lezyonun şekli nasıldır? = *[shape\_UlceroLesion/küçük yüzeysel ülserler, dev elmas (diamond shape), düzensiz sınırlı: küçük yüzeysel ülserler; normal=yok]* şeklindedir.

what is the shape of the third ulcerated lesion? = *[shape\_UlceroLesion/small superficial ulcers, giant diamond ulcer, irregular restrictive]*.

Üçüncü ülsere lezyonun *[shape\_UlceroLesion]* şeklindedir.

The shape of the third ulcerated lesion is *[shape\_UlceroLesion/small superficial ulcers, giant diamond ulcer, irregular restrictive]*.

**Condition 4:** *[lesionNumber] == “multiple”*

(a) En küçük ülsere lezyonun boyutu ne kadardır? = *[size/length: 0.5 cm ; min=0 cm, max=0 cm]* dir.

What is the size of the smallest ulcerated lesion? = *[size]*.

En küçük ülsere lezyonun boyutu  $[size]$  dir.

The size of the smallest ulcerated lesion is  $[size]$  .

**Condition 1:**  $CU([size], 'cm') > 0$

– En küçük ülsere lezyonun şekli nasıldır? =  $[shape\_UlcerLesion/küçük yüzeysel ülserler, dev elmas (diomond shape), düzensiz sınırlı: küçük yüzeysel ülserler; normal=yok]$  şeklindedir.

what is the shape of the smallest ulcerated lesion? =  $[shape\_UlcerLesion/small superficial ulcers, giant diamond ulcer, irregular restrictive]$ .

En küçük ülsere lezyonun  $[shape\_UlcerLesion]$  şeklindedir.

The shape of the first ulcerated lesion is  $[shape\_UlcerLesion/small superficial ulcers, giant diamond ulcer, irregular restrictive]$ .

**Condition 5:**  $[lesionNumber] ==$  “multiple”

(a) En büyük ülsere lezyonun boyutu ne kadardır? =  $[size/length: 2.5 cm ; min=0 cm, max=0 cm]$  dir.

What is the size of the largest ulcerated lesion? =  $[size]$ .

En büyük ülsere lezyonun boyutu  $[size]$  cm dir.

The size of the largest ulcerated lesion is  $[size]$ .

**Condition 1:**  $CU([size], 'cm') > 0$

– En büyük ülsere lezyonun şekli nasıldır? =  $[shape\_UlcerLesion/küçük yüzeysel ülserler, dev elmas (diomond shape), düzensiz sınırlı: küçük yüzeysel ülserler; normal=yok]$  şeklindedir.

what is the shape of the largest ulcerated lesion? =  $[shape\_UlcerLesion/small superficial ulcers, giant diamond ulcer, irregular restrictive]$ .

En büyük ülsere lezyonun  $[shape\_UlcerLesion]$  şeklindedir.

The shape of the largest ulcerated lesion is  $[shape\_UlcerLesion/small superficial ulcers, giant diamond ulcer, irregular restric-$

tive].

9. Özafagusta dolum fazlalığı var mıdır? = [filling\_diverducular/yoktur, vardır: yoktur; normal=yoktur].

Is there an outpouching in the esophagus? = [filling\_diverducular/There isn't, There is].

Özafagusta dolum fazlalığı [filling\_diverducular].

[filling\_diverducular/There isn't, There is] an outpouching in the esophagus.

**Condition 1:** [filling\_diverducular] == “vardır”

• Dolum fazlalığı kaç tanedir? = [number\_diverducular/1, 2, 3, multiple: 1; normal=yok] tanedir.

How many outpouchings are there? = [number\_diverducular/1, 2, 3, multiple].

Dolum fazlalığı [number\_diverducular] tanedir.

The number of outpouchings is [number\_diverducular/1, 2, 3, multiple].

**Condition 1:** [number\_diverducular] > 0 && [number\_diverducular] < 4

(a) İlk dolum fazlalığı seviyesi nedir? = [level/proksimal 1/3 özafagus, orta 1/3 özafagus, distal 1/3 özafagus, tüm özafagus: proksimal 1/3 özafagus; normal=yok]tur.

What is the level of the first outpouching? = [level/proximal 1/3 esophagus, middle 1/3 esophagus, distal 1/3 esophagus, whole esophagus].

İlk dolum fazlalığı seviyesi [level]tur.

The level of the first outpouching is [level/proximal 1/3 esophagus, middle 1/3 esophagus, distal 1/3 esophagus, whole esophagus].

**Condition 1:** [level] != “”

– İlk dolum fazlalığı nerededir? = [place\_fillingDiverducular/orta hattadır, arkadadır, lateraldedir: orta hattadır; normal=yok].

where is theoutpouching filling? = [place\_fillingDiverducular/middle outline, back, lateral].



İlk dolum fazlalığı  $[place\_fillingDiverducular]$ .

The first outpouching is in  $[place\_fillingDiverducular/middle\ outline, back, lateral]$ .

**Condition 1:**  $[place\_fillingDiverducular] \neq ""$

i. İlk dolum fazlalığının boyutu ne kadardır? =  $[size/length: 1.5\ cm; min=0\ cm, max=0\ cm]$  dir.

What is the size of the first outpouching ? =  $[size]$ .

İlk dolum fazlalığının boyutu  $[size]$  dir.

The size of the outpouching is  $[size]$ .

**Condition 2:**  $[number\_diverducular] > 1 \ \&\& \ [number\_diverducular] < 4$

(a) İkinci dolum fazlalığı seviyesi nedir? =  $[level/proksimal\ 1/3\ oesophagus, orta\ 1/3\ oesophagus, distal\ 1/3\ oesophagus, tüm\ oesophagus: proksimal\ 1/3\ oesophagus; normal=yok]$ tur.

What is the level of the second outpouching? =  $[level/proximal\ 1/3\ esophagus, middle\ 1/3\ esophagus, distal\ 1/3\ esophagus, whole\ esophagus]$ .

İkinci dolum fazlalığı seviyesi  $[level]$ tur.

The level of the second outpouching is  $[level/proximal\ 1/3\ esophagus, middle\ 1/3\ esophagus, distal\ 1/3\ esophagus, whole\ esophagus]$ .

**Condition 1:**  $[level] \neq ""$

– İkinci dolum fazlalığı nerededir? =  $[place\_fillingDiverducular/orta\ hattadır, arkadadır, lateraldedir: orta\ hattadır; normal=yok]$ .

where is the second outpouching ? =  $[place\_fillingDiverducular/middle\ outline, back, lateral]$ .

İkinci dolum fazlalığı  $[place\_fillingDiverducular]$ .

The second outpouching is in  $[place\_fillingDiverducular/middle\ outline, back, lateral]$ .

**Condition 1:**  $[place\_fillingDiverducular] \neq \text{“”}$

i. İkinci dolum fazlalığının boyutu ne kadardır? =  $[size/length: 1.5\text{ cm}; min=0\text{ cm}, max=0\text{ cm}]$  dir.

What is the size of the second outpouching ? =  $[size]$ .

İkinci dolum fazlalığının boyutu  $[size]$  dir.

The size of the second outpouching is  $[size]$ .

**Condition 3:**  $[number\_diverducular] > 2 \ \&\& \ [number\_diverducular] < 4$

(a) Üçüncü dolum fazlalığı seviyesi nedir? =  $[level/proksimal\ 1/3\ özafagus, orta\ 1/3\ özafagus, distal\ 1/3\ özafagus, tüm\ özafagus: proksimal\ 1/3\ özafagus; normal=yok/tur]$ .

What is the level of the third outpouching? =  $[level/proximal\ 1/3\ esophagus, middle\ 1/3\ esophagus, distal\ 1/3\ esophagus, whole\ esophagus]$ .

Üçüncü dolum fazlalığı seviyesi  $[level/tur]$ .

The level of the third outpouching is  $[level/proximal\ 1/3\ esophagus, middle\ 1/3\ esophagus, distal\ 1/3\ esophagus, whole\ esophagus]$ .

**Condition 1:**  $[level] \neq \text{“”}$

– Üçüncü dolum fazlalığı nerededir? =  $[place\_fillingDiverducular/orta\ hattadır, arkadadır, lateraldedir: orta\ hattadır; normal=yok]$ .

where is the third outpouching ? =  $[place\_fillingDiverducular/middle\ outline, back, lateral]$ .

Üçüncü dolum fazlalığı  $[place\_fillingDiverducular]$ .

The third outpouching is in  $[place\_fillingDiverducular/middle\ outline, back, lateral]$ .

**Condition 1:**  $[place\_fillingDiverducular] \neq \text{“”}$

i. Üçüncü dolum fazlalığının boyutu ne kadardır? =  $[size/length: 1.5\text{ cm}; min=0\text{ cm}, max=0\text{ cm}]$  dir.

What is the size of the third outpouching? =  $[size]$ .

Üçüncü dolum fazlalığının boyutu  $[size]$  dir.

The size of the third outpouching is  $[size]$ .

**Condition 4:**  $[number\_diverducular] == \text{“multiple”}$

(a) En küçük dolum fazlalığı seviyesi nedir? =  $[level/proksimal\ 1/3\ özafagus, orta\ 1/3\ özafagus, distal\ 1/3\ özafagus, tüm\ özafagus: proksimal\ 1/3\ özafagus; normal=yok]$ tur.

What is the level of the smallest outpouching? =  $[level/proximal\ 1/3\ esophagus, middle\ 1/3\ esophagus, distal\ 1/3\ esophagus, whole\ esophagus]$ .

En küçük dolum fazlalığı seviyesi  $[level]$ tur.

The level of the smallest outpouching is  $[level/proximal\ 1/3\ esophagus, middle\ 1/3\ esophagus, distal\ 1/3\ esophagus, whole\ esophagus]$ .

**Condition 1:**  $[level] != \text{“”}$

– En küçük dolum fazlalığı nerededir? =  $[place\_fillingDiverducular/orta\ hattadır, arkadadır, lateraldedir: orta\ hattadır; normal=yok]$ .

where is the smallest outpouching ? =  $[place\_fillingDiverducular/middle\ outline, back, lateral]$ .

En küçük dolum fazlalığı  $[place\_fillingDiverducular]$ .

The smallest outpouching is in  $[place\_fillingDiverducular/middle\ outline, back, lateral]$ .

**Condition 1:**  $[place\_fillingDiverducular] != \text{“”}$

i. En küçük dolum fazlalığının boyutu ne kadardır? =  $[size/length: 1.5\ cm; min=0\ cm, max=0\ cm]$  dir.

What is the size of the smallest outpouching? =  $[size]$ .

En küçük dolum fazlalığının boyutu  $[size]$  dir.

The size of the smallest outpouching is  $[size]$ .

**Condition 5:**  $[number\_diverducular] == \text{“multiple”}$

(a) En büyük dolum fazlalığı seviyesi nedir? =  $[level/proksimal\ 1/3\ özafagus, orta\ 1/3\ özafagus, distal\ 1/3\ özafagus, tüm\ özafagus: proksimal\ 1/3\ özafagus; normal=yok]$ tur.

What is the level of the largest outpouching? =  $[level/proximal\ 1/3\ esophagus, middle\ 1/3\ esophagus, distal\ 1/3\ esophagus, whole\ esophagus]$ .

En büyük dolum fazlalığı seviyesi  $[level]$ tur.

The level of the largest outpouching is  $[level/proximal\ 1/3\ esophagus, middle\ 1/3\ esophagus, distal\ 1/3\ esophagus, whole\ esophagus]$ .

**Condition 1:**  $[level] != \text{“”}$

– En büyük dolum fazlalığı nerededir? =  $[place\_fillingDiverducular/orta\ hattadır, arkadadır, lateraldedir: orta\ hattadır; normal=yok]$ .

where is the largest outpouching? =  $[place\_fillingDiverducular/middle\ outline, back, lateral]$ .

En büyük dolum fazlalığı  $[place\_fillingDiverducular]$ .

The largest outpouching is in  $[place\_fillingDiverducular/middle\ outline, back, lateral]$ .

**Condition 1:**  $[place\_fillingDiverducular] != \text{“”}$

i. En büyük dolum fazlalığının boyutu ne kadardır? =  $[size/length: 1.5\ cm; min=0\ cm, max=0\ cm]$  dir.

What is the size of the largest outpouching? =  $[size]$ .

En büyük dolum fazlalığının boyutu  $[size]$  dir.

The size of the largest outpouching is  $[size]$ .

10. Kontrast maddenin geçişi sırasında özafagusta normal dışı belirgin genişleme var mı? =  $[dilatation/yoktur, vardır: yoktur; normal=yoktur]$

Is there any significant abnormal dilatation in esophagus during the transition of contrast media? =  $[dilatation/There\ isn't, There\ is]$ .

Kontrast maddenin geçişi sırasında özafagusta normal dışı belirgin genişleme  $[dilatation]$ .

*[dilatation/There isn't, There is]* significant abnormal dilatation in esophagus during the transition of contrast media.

**Condition 1:** *[dilatation]* == “vardır”

- Normal dışı belirgin genişleme özafagusun neresindedir? = *[dilatation\_place/proksimal 1/3 özafagus, orta 1/3 özafagus, distal 1/3 özafagus, tüm özafagus: proksimal 1/3 özafagus; normal=yok]*tadır.

Where is the significant abnormal dilatation in esophagus? = *[dilatation\_place/proximal 1/3 esophagus, middle 1/3 esophagus, distal 1/3 esophagus, whole esophagus]*.

Normal dışı belirgin genişleme *[dilatation\_place]*tadır.

The significant abnormal dilatation in esophagus is *[dilatation\_place/proximal 1/3 esophagus, middle 1/3 esophagus, distal 1/3 esophagus, whole esophagus]*.

11. Özafagusta geçirilmiş cerrahi müdahale var mıdır? = *[operation/yoktur, vardır: yoktur; normal=yoktur]*.

Is there any surgical operation in the esophagus? = *[operation/There isn't, There is]*.

Özafagusta geçirilmiş cerrahi müdahale *[operation]*.

*[operation/There isn't, There is]* surgical operation in the esophagus.

**Condition 1:** *[operation]* == “vardır”

- Anastomoz hattı genişliği nasıldır? = *[Anas\_line/normaldir, dardir: normaldir; normal=normaldir]*.

How is the wideness of anastomoses line? = *[Anas\_line/normal, narrow]*.

Anastomoz hattı genişliği *[Anas\_line]*.

The wideness of anastomoses line is *[Anas\_line/normal, narrow]*.

12. Distal özafagusta herni var mıdır? = *[hernia/yoktur, vardır: yoktur; normal=yoktur]*.

Is there hernia in the distal esophagus? = *[hernia/There isn't, There is]*.

Distal özafagusta herni *[hernia]*.

*[hernia/There isn't, There is]* hernia in the distal esophagus.

**Condition 1:** *[hernia]* == “vardır”

- Herni hangi tip bir hernidir?=*[hernia\_type/kayma, paraözofajeal, mixed, kısa özafagus: kayma; normal=yok]* tipindedir.

What is the type of hernia?=*[hernia\_type/sliding, paraesophag, mixed, short esophagus]*

Herni *[hernia\_type]* tipindedir.

The type of esophagus is *[hernia\_type/sliding, paraesophag, mixed, short esophagus]*

13. Gastroözafagiye reflü var mıdır?=*[reflux/yoktur, vardır, test edilmedi: yoktur; normal=yoktur]*.

Is there a gastro-esophagus reflux?=*[reflux/There isn't, There is, Not tested]*.

Gastroözafagiye reflü *[reflux]*.

*[reflux/There isn't, There is, Not tested]* a gastro-esophagus reflux.

# Appendix B

## A QUESTIONNAIRE TO EVALUATE THE ACCEPTANCE OF THE SISDS METHODOLOGY

The most common data collecting methods itemized below including SISDS in medical reporting are compared to each other by the questionnaire in terms of the questions enumerated below. All questions are close ended and have multiple options. The options are depicted above the questions. The option character written at the end of each question in parenthesis indicate which options itemized above the questions are taken into consideration for the current question. Each question is asked to the users and evaluated for every method one by one as depicted in Figure B.1.

1. Do you agree that a targeted and desired quality of care can be delivered through uniform work practices with the current model?

<b>HANDWRITING</b>	Totally Agree	▼
<b>TOS</b>	Totally Agree	▼
<b>RTTOS</b>	Totally Agree	▼
<b>TELEPHONE</b>	Totally Agree	▼
<b>DBSR</b>	Totally Agree	▼
<b>ASDCIAS</b>	Totally Agree	▼
<b>SISDS</b>	Totally Agree	▼

Figure B.1: An example for the questionnaire.

METHODS EVALUATED IN THE QUESTIONNAIRE:

- HANDWRITING

- TOS (TRANSCRIPTIONIST-ORIENTED SYSTEMS (Recorded speech files to be dictated later by medical transcriptionists))
- RTTOS (REAL TIME TRANSCRIPTIONIST-ORIENTED SYSTEMS (Recording in real-time using medical transcriptionists))
- TELEPHONE (TELEPHONE ACCESS (automated voice recording system))
- DBSR (DICTATION BY SPEECH RECOGNITION)
- ASDCS (ALL STRUCTURED DATA COLLECTED IN A SCREEN)
- SISDS (Structured, Interactive, Standardized and Decision Supporting Methodology)



Options for the questions in the questionnaire in English:

- (a) Totally Agree, Agree, Neither Agree Nor Disagree , Disagree, Totally Disagree
- (b) Totally Prefer, Prefer, No Idea, Not Prefer, Totally Not Prefer
- (c) Totally Recommend, Partially Recommend, No Idea, Partially Not Recommend, Totally Not Recommend
- (d) Totally Think, Think, No Idea, Not Think, Totally Not Think
- (e) Totally Believe, Believe, No Idea, Not Believe, Totally Not Believe
- (f) About an Hour, 1-3 Hours, 3-9 Hours, About a day, 1-6 Days, About a Week, More Than a Week
- (g) Still Using, Used Partially, Never used

### **Questions**

1. Do you agree that a targeted and desired quality of care can be delivered through uniform work practices with the current model? (a)
2. Do you agree that users are guided thoroughly through details to analyze correctly with the current model? (a)
3. Do you agree that the current model provides an educational/training support? (a)
4. Do you agree that the current model is user-friendly? (a)
5. Do you agree that the current model will sure increase the overall level of job performance and provide faster response to physician's clinical orders? (a)
6. Do you agree that recruits will be oriented faster with the current model? (a)
7. Do you agree that the current model will increase employee autonomy, enhancing employee empowerment, improving individual competence and tailorability? (a)
8. Do you agree that the training cost of recruits will be reduced with the current model? (a)
9. Do you agree that the current model will provide same medical reporting quality for every case in terms of the differences between inexperienced and experienced? (a)

10. Do you agree that the current model will standardize the working processes better?  
(a)
11. Do you believe that the current model will increase healthcare professionals' productivity? (e)
12. Do you agree that your unit will get a continuous improvement of complex and changing tasks in your learning organization? (a)
13. Do you agree that knowledge capture and capitalization, management of knowledge systematically and institutionalizing best practice will be provided well with the current model? (a)
14. Do you agree that the current model is providing a data/information base or ideal domain, content management, consistent content while medical reporting? (a)
15. Do you agree that the current model will store more quality structured data for further analysis and research? (a)
16. Do you agree that the current model is better in terms of reducing medical error and improving patient safety? (a)
17. Do you agree that the current model will reduce the cost of transcriptionist usage? (a)
18. Do you agree that the current method will preserve the privacy and confidentiality between experts and patients? (a)
19. Do you agree that the current model will preserve the hygienic working environment while medical reporting (anjio, ultrasound etc)? (a)
20. Do you agree that the current model will support examining physicians while diagnosing process through examining data in prepared medical reports? (a)
21. Do you agree that the current model will provide an advisory diagnosis itself in view of the previous prepared reports including their diagnoses? (a)
22. Do you agree that the current model will prevent the lesion blindness during reporting process? (a)
23. Do you agree that the current model will increase patients' satisfaction? (a)
24. Do you prefer to use the current model while medical reporting? (b)

25. Do you recommend the current model to health professionals to use while medical reporting? (c)
26. Do you think that the current model will increase healthcare professionals' job satisfaction? (d)
27. Do you agree that you will focus the processes better while reporting with the current model? (a)
28. Do you think that the current model is overall cost-efficient? (d)
29. Do you think that the current model will decrease system maintenance and support cost? (d)
30. Do you think that the current model can meet the overall desired benefits in terms of its all functions? (d)
31. How long does it take you to learn the current model with all its functions to form an ideal medical report? (f)
32. Which model have you used up to now and which model are you still using right now? (g)

Options for the questions in the questionnaire in Turkish:

- (a) Kesinlikle Katılıyorum, Katılıyorum, Ne Katılıyorum ne de Katılmıyorum, Katılmıyorum, Kesinlikle Katılmıyorum
- (b) Kesinlikle Tercih Ederim, Tercih Ederim, Fikrim Yok, Tercih Etmem, Kesinlikle Tercih Etmem
- (c) Kesinlikle Öneririm, Kısmen Öneririm, Fikrim Yok, Kısmen Önermem, Kesinlikle Önermem
- (d) Kesinlikle Düşünüyorum, Düşünüyorum, Fikrim Yok, Düşünmüyorum, Kesinlikle Düşünmüyorum
- (e) Kesinlikle İnanıyorum, İnanıyorum, Fikrim Yok, İnanmıyorum, Kesinlikle İnanmıyorum
- (f) Bir Saat, 1-3 Saat, 3-9 Saat, Bir Gün, 1-6 Gün, Bir Hafta, Bir Haftadan Fazla
- (g) Halen kullanmaktayım, Kısmen Kullandım, Hiç kullanmadım

### Questions

1. İlgili yöntemle, farklı uzmanlar tarafından, her seferinde, hedeflenen ve arzulanan kalitede hizmet verilebileceğine katılıyor musunuz? (a)
2. İlgili yöntemle, yapılan değerlendirmenin, doğru ve tam olarak yapılabilmesi için, kullanıcıların doğru olarak yönlendirilebileceğine katılıyor musunuz? (a)
3. İlgili yöntemin öğretici ve eğitici olduğuna katılıyor musunuz? (a)
4. İlgili yöntemin kullanıcı dostu olduğuna katılıyor musunuz? (a)
5. İlgili yöntemin, iş performansını arttıracığına, tıbbi rapor oluştururken, raporu kullanıma sunum açısından performans etkin olduğuna katılıyor musunuz? (a)
6. İlgili yöntemle, işe yeni başlayan personelin daha çabuk oriente olabileceğine katılıyor musunuz? (a)
7. İlgili yöntemin, kullanıcıya daha bağımsız(başka birine ihtiyaç duymadan) bir çalışma ortamı sağlayacağına katılıyor musunuz? (a)
8. İlgili yöntemin, işe yeni başlayan personelin eğitilmesi maliyetlerini düşüreceğine katılıyor musunuz? (a)

9. İlgili yöntemin, en uzman ve en acemi arasında, kullanım esnasında aynı kalitede raporlama hizmeti sunabileceğine katılıyor musunuz? (a)
10. İlgili yöntemin, yapılan işi daha standart bir hale getireceğine katılıyor musunuz? (a)
11. İlgili yöntemle çalışanın verimliliğinin artacağına inanıyor musunuz? (e)
12. İlgili yöntemi kullanarak, biriminizin, belli politikalar uygulanarak devamlı bir gelişme içerisinde olabileceğine katılıyor musunuz? (a)
13. İlgili yöntemi kullanarak, üstbilginin(knowledge) daha iyi yönetilebileceğine katılıyor musunuz? (a)
14. İlgili yöntemin, raporun ideal bir şekilde doldurulması maksadı ile yeterli bilgiye ulaşım desteği sağladığına katılıyor musunuz? (a)
15. İlgili yöntemin, ileride araştırma yapacaklar için daha kaliteli yapısal veri oluşturulabileceğine katılıyor musunuz? (a)
16. İlgili yöntemin, hasta sağlığı ve tıbbi hataların azaltılması açısından, daha sağlıklı olduğuna katılıyor musunuz? (a)
17. İlgili yöntemin, tıbbi sekreter kullanımını azaltacağına katılıyor musunuz? (a)
18. İlgili yöntemin, tıbbi raporlama esnasında, uzmanla hasta arasındaki mahremiyeti koruyabileceğine katılıyor musunuz? (a)
19. İlgili yöntemin, anjio, ultrasound vb raporların oluşturulması esnasında hijyenik çalışma ortamlarını koruyabileceğini düşünüyor musunuz? (d)
20. İlgili yöntemin kullanılmasının, raporu değerlendirecek uzmanlar açısından baktığımızda, oluşturulmuş olan rapordaki verilerin değerlendirilmesinde, koyulacak olan tanının daha doğru olmasına katkı sağlayacağına katılıyor musunuz? (a)
21. İlgili yöntemin, önceki benzer raporlar ışığında, kendiliğinden öğrenerek, doğru karara yönelik tavsiye niteliğinde tam koyabileceğine katılıyor musunuz? (a)
22. İlgili yöntemin, raporlama esnasında lezyon körlüğünü önleyebileceğine katılıyor musunuz? (a)
23. İlgili yöntemin kullanılmasıyla, hizmet alan hasta memnuniyetinin artacağına katılıyor musunuz? (a)

24. İlgili yöntemi, tıbbi raporlarınızı oluştururken kullanmayı tercih eder misiniz? (b)
25. İlgili yöntemi, uzmanların raporlarını oluştururken, kullanmalarını önerir misiniz? (c)
26. İlgili yöntemin iş tatminini arttıracakını düşünüyor musunuz? (d)
27. İlgili yöntemin, rapor oluştururken, yapılan işe daha fazla odaklanma sağlayacağına katılıyor musunuz? (a)
28. İlgili yöntemin daha maliyet etkin olduğunu düşünüyor musunuz? (d)
29. İlgili yöntemle, sistem bakım ve geliştirme maliyetlerinin daha az olabileceğini düşünüyor musunuz? (d)
30. İlgili yöntemin, tüm parametreleri ile bir değerlendirme yaptığınızda, elde edilmek istenen tüm faydaları karşılayabileceğini düşünüyor musunuz? (d)
31. İlgili yöntemini, ideal rapor oluşturma açısından baktığınızda tüm fonksiyonları ile ne kadar zamanda öğrenebildiniz? (f)
32. Siz şimdiye kadar hangi yöntemi kullandınız ve halen kullanmakta olduğunuz yöntem hangisidir? (g)

Table B.1: Question numbers in the questionnaire to measure the criterions: A:Quality of care; B:Data quality; C:Management of knowledge and DSS; D:Research; E:Reducing medical error and improving patient safety; F:Cognitive overload; G:Distribution time (faster response); H:Overall cost; I:Educational/training; J:User-friendly; K:User-productivity(number of reports / time); L:Patients' satisfaction; M:Satisfaction of referring physicians; N:Satisfaction of laboratory professionals; O:EPSS; P:Learning organization. For instance, the question numbers of 1, 9, 11, 14, 15, 16, 19, 20, 21, 22, 23, 27, 30 are averaged to measure the "quality of care" as well as the numbers of 3, 4, 5, 6, 7, 11, 14, 27, 30 are averaged to measure "user-productivity(number of reports / time)"; as you see the numbers of 11, 14, 27 and 30 are included in the evaluation of both criterions.

	1	2	3	4	5	6	7	8	9	10	11	12	13	14	15	16	17	18	19	20	21	22	23	24	25	26	27	28	29	30	31	
A	X								X		X			X	X	X			X	X	X	X					X			X		
B	X	X						X	X	X				X	X															X		
C		X	X				X		X	X		X	X							X	X	X							X			
D			X										X	X	X														X			
E		X							X							X			X			X							X			
F	X	X		X			X			X				X												X	X			X	X	
G					X		X				X																	X		X		
H					X		X				X						X											X		X		
I		X	X			X	X	X					X	X	X						X	X					X	X		X		
J			X																								X					
K			X	X	X	X	X				X			X			X										X			X		
L	X				X				X		X					X			X				X						X			
M	X				X				X	X	X			X	X						X			X					X	X		
N			X	X			X																	X	X	X	X		X			
O		X	X			X	X	X					X	X	X						X	X						X		X		
P			X				X					X	X	X	X						X	X							X			

## Appendix C

### THE ER DIAGRAM OF THE DATABASE

The notations of report segments to present data entries and to collect data are stored in the table of *question* in the database as presented in the syntax in Table 4.1: the definitions of data entries such as segment-length and defect are kept in the field of *def* in the table of *question* as a text, and the application analyze this field for data entries to present and collect data by checking their constraints that is defined in this field; similarly, the notation of report wide triggers is stored in the table of *qset* in which the report wide trigger conditions are kept in the field of *cond* including the name of the data field, the equations and the required values of the data fields such as (*[outlines]* == “irregular”) as well as the notation of triggering advices and diagnoses are stored in the table of *report-trigger* in which the report wide trigger conditions are kept in the field of *cond* including the label, the name, the equation and the required value such as (*[10.diameter]* > 8), there is a one-to-many relation from *report* in which the unique report names are defined to *qset* and *report-trigger*. The table of *patient-icd10* is for the codes of diagnosis information of patients and *icd10* is for the definitions of these, having one-to-one relation between them; the table of *patient* is for the general information of patients (name, sex, age, etc): there is a one-to-many relation from *patient* to *patient-icd10*, that is, a patient may have more than one diagnosis; the table of *answers* in which the name of the data fields and their values are kept is for the data entries in reports generated for patients and there is a one-to-many relation from *patient* to *answers* and one-to-one relation from *answers* to *questions*; image files and other extra information that may be uploaded are stored in the table of *pfile*, there is a one-to-many relation from *patient* to *pfile*.



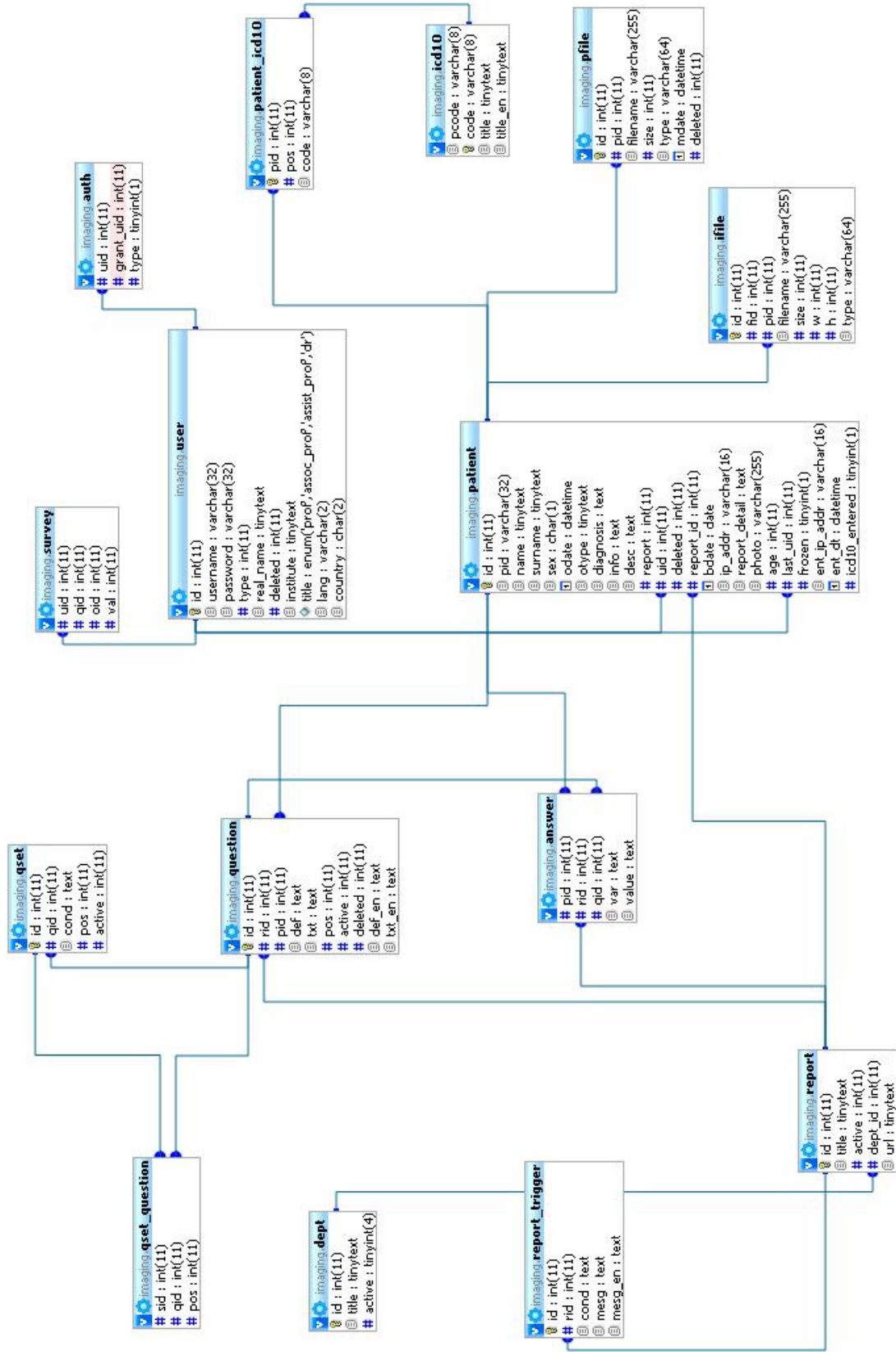

Figure C.1: ER diagram of the SISDS methodology.

## Appendix D

# COMPARISON OF THE COMPLEXITY, VALUE, AND CHARACTERISTICS OF INFORMATION CAPTURE STYLES

Unstructured systems are least complex and have lower value, interactive systems are most complex and have higher value whereas structured systems are somewhere between unstructured and interactive systems Table D.1. Another representation of unstructured, structured and interactive information capture concepts to better understand the complexity, value, and characteristics of the different information capture styles and technologies by Waagemann et al. (2002) is presented in Table D.2.

Table D.1: Complexity, Value, and Characteristics of Information

Unstructured	Structured	Interactive
<ul style="list-style-type: none"> <li>••Handwriting.</li> <li>••Voice recording (dictation).</li> <li>••The use of transcription to convert unstructured handwriting or voice into ASCII computer text that is more readable but still unstructured.</li> <li>••Direct entry by clinicians using free text (unstructured) keyboard entry.</li> </ul>	<ul style="list-style-type: none"> <li>••Static, fixed.</li> <li>••Information entry guided by templates.</li> <li>••Information entry guided by prompts given visually on a screen or audibly with voice response technology.</li> <li>••Guided choice using point and click touch screen, light pens, etc.</li> <li>••Data entry via standardized controlled vocabularies using point and click.</li> <li>••Speech recognition with the ability to parse the input into discrete words or data.</li> <li>••The use of XML tags to identify data or text within a template or after parsing from voice recognition.</li> <li>••The use of XML document type definitions (DTDs) to organize input into a standardized document.</li> <li>••The use of transcription along with templates and/or XML to make the information more structured.</li> <li>••Translation of text or data into codes.</li> <li>••The completion of templated forms, combined with dictation, then integration of data from scanned forms with transcription.</li> <li>••Information sent from other computer devices structured with a standard syntax.</li> <li>••Data automatically captured from medical devices and possibly translated into structured text (e.g., XML).</li> </ul>	<ul style="list-style-type: none"> <li>••As structured text and data, it compares this information against pre-stored information, knowledge, or rules and then responds to the user. This is a dynamic process. The responses may include: <ul style="list-style-type: none"> <li>••A branch to a sub-set of questions that is specifically relevant to a user response (such as drill-down questions, problem knowledge couplers).</li> <li>••An alert, warning, or reminder triggered by data comparisons and knowledge rules.</li> <li>••A clinical protocol or practice guideline triggered by a specific user response.</li> <li>••A pre-approved drug formulary triggered by a medication order.</li> <li>••A presentation of clinical tests or therapies with their relative costs triggered by a user entry of preliminary findings or diagnoses.</li> </ul> </li> </ul>

Capture Styles

Table D.2: Information Capture Matrix

	<b>Unstructured</b>	<b>Structured</b>	<b>Interactive</b>
<b>Ongoing cost to capture information</b>	Low to capture information, relatively high to retrieve information, moderate to expensive to transcribe information.	Low to capture information, low to retrieve information, moderate to expensive to transcribe information.	Low to capture information, low to retrieve information.
<b>Capability to improve quality of care</b>	Limited to the availability of this information at the next episode of care and to its readability and completeness.	Enhanced because the information is available immediately and probably meets uniform standards for completeness, accuracy, etc.	Greatly enhanced by the availability of relevant information and clinical decision support at the time when care is being provided.
<b>Capability to reduce medical errors and improve patient safety</b>	Little impact.	Better documentation may or may not improve the current episode of care, but it does provide improvements for subsequent episodes of care.	Improvement at the time of care as well as for subsequent episodes of care.
<b>Improvement in clinical research</b>	Relatively low.	Improved because the information meets a standard level for completeness and accuracy.	Significant improvement because the information is appropriate for specific conditions and situations.
<b>Improvement in public health</b>	Relatively low.	Improved because the information meets a standard level for completeness and accuracy.	Significant improvement because the information is appropriate for specific conditions and situations.

## Appendix E

### THE INPUT ATTRIBUTE LIST USED IN BUILDING DDSS

- @attribute sex (M,F,O)
- @attribute age numeric
- @attribute 111\_position (yatarak prone oblik, erekt sol oblik, erekt sol lateral, erekt sağ lateral, semierekt, supin, trandelenburg, yatarak ve ayaktan,?)
- @attribute 112\_contrast (baryum maddesi, suda erir kontrast madde, damar içi kontrast madde,?)
- @attribute 113\_extravasating (yoktur, vardır,?)
- @attribute 114\_section (proksimal 1/3 özafagus, orta 1/3 özafagus, distal 1/3 özafagus, tüm özafagus,?)
- @attribute 115\_transition (beklemeden normal hızla olmuştur, bekleyerek olmuştur, bekleyerek belirli seviye oluştuktan sonra olmuştur, olmamıştır,?)
- @attribute 116\_level (1/3 üst özafagusta, 1/3 orta özafagusta, 1/3 alt özafagusta, tüm özafagus boyunca,?)
- @attribute 117\_peristalsis\_wave (primer, primer seconder, primer seconder tersiyer, belirgin olarak izlenmemiş, azalmış, tersiyer,?)
- @attribute 118\_level (proksimal 1/3 özafagusta, orta 1/3 özafagusta, distal 1/3 özafagusta, tüm özafagus bölümlerinde diffüz spazm (tirbüşon özafagus) görüntüsünde, orta distal,?)

- @attribute 119\_section (proksimal 1/3 özafagus, orta 1/3 özafagus, distal 1/3 özafagus, tüm özafagus,?)
- @attribute 120\_narrowness (yok,var,?)
- @attribute 121\_section (proksimal 1/3 özafagus, orta 1/3 özafagus, distal 1/3 özafagus, tüm özafagus, proksimal + orta 1/3 özafagus, proksimal + distal 1/3 özafagus, orta + distal 1/3 özafagus,?)
- @attribute 124\_length numeric
- @attribute 125\_settlement (simetrik, asimetrik,?)
- @attribute 126\_segment (düzenli, düzensiz,?)
- @attribute 122\_relief (normal,normal değil,?)
- @attribute 123\_topography (kalınlaşmış mukozal kıvrımlar görünümde, retüküler mukozal patern görünümde, mukozal nodüler görünümde, ince transvers mukozal çizgiler (feline özafagus) görünümde,?)
- @attribute 182\_relief\_level (proksimal 1/3 özafagus, orta 1/3 özafagus, distal 1/3 özafagus, tüm özafagus, proksimal + orta 1/3 özafagus, proksimal + distal 1/3 özafagus, orta + distal 1/3 özafagus,?)
- @attribute 127\_defect (yoktur,vardır,?)
- @attribute 128\_defectNumber (1,2,3,multiple,?)
- @attribute 129\_level (proksimal 1/3 özafagustur, orta 1/3 özafagustur, distal 1/3 özafagustur, tüm özafagustur, özafagus mide birleşim düzeyidir, özafagusgastrik bileşkedir,?)
- @attribute 130\_defect (düzgün çizgisel yapı, düzensiz polipoid sapsız, düzensiz polipoid sapsız, düzensiz polipoid ülsere, yılanvari kıvrıntılı dolun, çizgili plaklar, nodüler,?)
- @attribute 131\_size numeric
- @attribute 132\_level (proksimal 1/3 özafagustur, orta 1/3 özafagustur, distal 1/3 özafagustur, tüm özafagustur, özafagus mide birleşim düzeyidir, özafagusgastrik bileşkedir,?)
- @attribute 136\_defect (düzgün çizgisel yapı, düzensiz polipoid sapsız, düzensiz polipoid sapsız, düzensiz polipoid ülsere, yılanvari kıvrıntılı dolun, çizgili plaklar, nodüler,?)

- @attribute 140\_size numeric
- @attribute 133\_level (proksimal 1/3 özafagustur, orta 1/3 özafagustur, distal 1/3 özafagustur, tüm özafagustur, özafagus mide birleşim düzeyidir, özafagusgastrik bileşkedir,?)
- @attribute 137\_defect (düzgün çizgisel yapı, düzensiz polipoid saplı, düzensiz polipoid sapsız, düzensiz polipoid ülsere, yılanvari kıvrıntılı dolun, çizgili plaklar, nodüler,?)
- @attribute 141\_size numeric
- @attribute 134\_level (proksimal 1/3 özafagustur, orta 1/3 özafagustur, distal 1/3 özafagustur, tüm özafagustur, özafagus mide birleşim düzeyidir, özafagusgastrik bileşkedir,?)
- @attribute 138\_defect (düzgün çizgisel yapı, düzensiz polipoid saplı, düzensiz polipoid sapsız, düzensiz polipoid ülsere, yılanvari kıvrıntılı dolun, çizgili plaklar, nodüler,?)
- @attribute 142\_size numeric
- @attribute 135\_level (proksimal 1/3 özafagustur, orta 1/3 özafagustur, distal 1/3 özafagustur, tüm özafagustur, özafagus mide birleşim düzeyidir, özafagusgastrik bileşkedir,?)
- @attribute 139\_defect (düzgün çizgisel yapı, düzensiz polipoid saplı, düzensiz polipoid sapsız, düzensiz polipoid ülsere, yılanvari kıvrıntılı dolun, çizgili plaklar, nodüler,?)
- @attribute 143\_size numeric
- @attribute 144\_ulcero\_lezyon (yoktur,vardır,?)
- @attribute 145\_lesionNumber (1,2,3,multiple,?)
- @attribute 146\_size numeric
- @attribute 147\_shape\_UlceroLesion (küçük yüzeysel ülserler, dev elmas (diamond shape), düzensiz sınırlı,?)
- @attribute 148\_size numeric
- @attribute 152\_shape\_UlceroLesion (küçük yüzeysel ülserler, dev elmas (diamond shape), düzensiz sınırlı,?)
- @attribute 149\_size numeric
- @attribute 153\_shape\_UlceroLesion (küçük yüzeysel ülserler, dev elmas (diamond shape), düzensiz sınırlı,?)

- @attribute 150\_size numeric
- @attribute 154\_shape\_UlceroLesion (küçük yüzeysel ülserler, dev elmas (diamond shape), düzensiz sınırlı,?)
- @attribute 151\_size numeric
- @attribute 155\_shape\_UlceroLesion (küçük yüzeysel ülserler, dev elmas (diamond shape), düzensiz sınırlı,?)
- @attribute 156\_filling\_Diverducular (yoktur, vardır,?)
- @attribute 157\_number\_Diverducular (1,2,3,multiple,?)
- @attribute 158\_level (proksimal 1/3 özafagus, orta 1/3 özafagus, distal 1/3 özafagus, tüm özafagus,?)
- @attribute 163\_place\_fillingDiverducular (orta hattadır, arkadadır, lateraldedir,?)
- @attribute 168\_size numeric
- @attribute 159\_level (proksimal 1/3 özafagus, orta 1/3 özafagus, distal 1/3 özafagus, tüm özafagus,?)
- @attribute 164\_place\_fillingDiverducular (orta hattadır, arkadadır, lateraldedir,?)
- @attribute 169\_size numeric
- @attribute 160\_level (proksimal 1/3 özafagus, orta 1/3 özafagus, distal 1/3 özafagus, tüm özafagus,?)
- @attribute 165\_place\_fillingDiverducular (orta hattadır, arkadadır, lateraldedir,?)
- @attribute 170\_size numeric
- @attribute 161\_level (proksimal 1/3 özafagus, orta 1/3 özafagus, distal 1/3 özafagus, tüm özafagus,?)
- @attribute 166\_place\_fillingDiverducular (orta hattadır, arkadadır, lateraldedir,?)
- @attribute 171\_size numeric
- @attribute 162\_level (proksimal 1/3 özafagus, orta 1/3 özafagus, distal 1/3 özafagus, tüm özafagus,?)



- @attribute 167\_place\_fillingDiverducular (orta hattadır, arkadadır, lateraldedir,?)
- @attribute 172\_size numeric
- @attribute 175\_dilatation (yoktur,vardır,?)
- @attribute 178\_dilatation\_place (proksimal 1/3 özafagus, orta 1/3 özafagus, distal 1/3 özafagus, tüm özafagus,?)
- @attribute 176\_operation (yoktur,vardır,?)
- @attribute 177\_Anas\_line (normaldir, dardır,?)
- @attribute 179\_hernia (yoktur,vardır,?)
- @attribute 180\_hernia\_type (kayma, paraözofajeal, mixed, kısa özafagus,?)
- @attribute 181\_reflux (yoktur,vardır,test edilmedi,?)

## Appendix F

# THE OUTPUT ATTRIBUTE LIST (ICD-10 DIAGNOSTIC CODES) USED IN BUILDING DDSS

- @attribute K22.0 0,1
- @attribute K21.9 0,1
- @attribute C16.0 0,1
- @attribute K76.6 0,1
- @attribute K22.5 0,1
- @attribute K22.4 0,1
- @attribute C25 0,1
- @attribute C15.5 0,1
- @attribute K20 0,1
- @attribute K23.8 0,1
- @attribute K22.8 0,1
- @attribute Z00.0 0,1
- @attribute Z13.9 0,1
- @attribute K22.1 0,1
- @attribute K22.9 0,1

- @attribute Z98.0 0,1
- @attribute C15.3 0,1
- @attribute K44.9 0,1
- @attribute K21.0 0,1
- @attribute Y84.4 0,1
- @attribute Q34.1 0,1
- @attribute C15.1 0,1
- @attribute C15.4 0,1
- @attribute Z02 0,1
- @attribute C15.9 0,1
- @attribute D13 0,1
- @attribute C15.0 0,1
- @attribute R13 0,1
- @attribute T28.6 0,1
- @attribute Y84.2 0,1
- @attribute T28.1 0,1
- @attribute Q39.4 0,1
- @attribute Q39.3 0,1
- @attribute K22.2 0,1
- @attribute Q25.4 0,1
- @attribute Q39.6 0,1
- @attribute K22.3 0,1
- @attribute A03.1 0,1
- @attribute Z21.9 0,1
- @attribute Z00 0,1







## Appendix H

# THE AVERAGE RATES AND ACCURACIES OF THE CLASSIFICATION ALGORITHMS FOR K22.4 DIAGNOSIS

Table H.1: Average rates and accuracies of the classification algorithms named ADTree and BayesNet for K22.4 diagnosis: TPR: True Positive Rate; TNR: True Negative Rate; A: Overall accuracy; the values at the right of the TPRs, the TNRs and the accuracies designate the variances.

	ADTree			BayesNet		
	TNR	TPR	A	TNR	TPR	A
	98,24 ± 0,00	76,21 ± 0,01	96,19 ± 0,00	97,34 ± 0,00	56,30 ± 0,03	93,52 ± 0,00
Cost Sen.	93,27 ± 0,00	84,13 ± 0,01	92,41 ± 0,00	95,29 ± 0,00	85,44 ± 0,02	94,37 ± 0,00
Bagging	98,33 ± 0,00	76,80 ± 0,01	96,32 ± 0,00	97,51 ± 0,00	59,40 ± 0,05	93,94 ± 0,00
CS. w/ Bagging	94,77 ± 0,00	84,13 ± 0,01	93,77 ± 0,00	96,32 ± 0,00	83,01 ± 0,01	95,09 ± 0,00
Info. Gain (8)	98,21 ± 0,00	77,41 ± 0,00	96,28 ± 0,00	98,61 ± 0,00	72,67 ± 0,00	96,16 ± 0,00
(16)	98,49 ± 0,00	77,05 ± 0,01	96,48 ± 0,00	98,22 ± 0,00	75,61 ± 0,01	96,12 ± 0,00
(32)	98,32 ± 0,00	76,88 ± 0,01	96,32 ± 0,00	97,35 ± 0,00	71,64 ± 0,04	94,94 ± 0,00
PCA (8)	99,21 ± 0,00	67,59 ± 0,03	96,25 ± 0,00	92,96 ± 0,01	85,61 ± 0,04	92,29 ± 0,00
(16)	99,08 ± 0,00	73,12 ± 0,02	96,66 ± 0,00	91,56 ± 0,00	88,81 ± 0,01	91,30 ± 0,00
(32)	98,47 ± 0,00	71,04 ± 0,13	95,90 ± 0,00	87,74 ± 0,00	92,92 ± 0,02	88,23 ± 0,00
Boosting	98,16 ± 0,00	75,16 ± 0,02	96,02 ± 0,00	98,00 ± 0,00	59,22 ± 0,12	94,38 ± 0,00
CS. w/ Boosting	95,93 ± 0,00	80,00 ± 0,04	94,44 ± 0,00	96,03 ± 0,00	82,58 ± 0,03	94,76 ± 0,00
BoostIG (8)	98,09 ± 0,00	75,09 ± 0,06	95,95 ± 0,00	98,41 ± 0,00	73,20 ± 0,02	96,05 ± 0,00
(16)	98,04 ± 0,00	76,71 ± 0,06	96,05 ± 0,00	98,20 ± 0,00	75,34 ± 0,03	96,06 ± 0,00
(32)	97,97 ± 0,00	75,60 ± 0,03	95,87 ± 0,00	97,83 ± 0,00	66,64 ± 0,14	94,91 ± 0,00
BoostPCA (8)	98,37 ± 0,00	70,61 ± 0,05	95,76 ± 0,00	98,70 ± 0,00	65,43 ± 0,08	95,58 ± 0,00
(16)	98,46 ± 0,00	70,79 ± 0,06	95,85 ± 0,00	98,90 ± 0,00	66,46 ± 0,05	95,86 ± 0,00
(32)	98,17 ± 0,00	71,31 ± 0,05	95,66 ± 0,00	98,81 ± 0,00	65,86 ± 0,06	95,72 ± 0,00



Table H.2: Average rates and accuracies of the classification algorithms named Logistic and SMO for K22.4 diagnosis. TPR: True Positive Rate; TNR: True Negative Rate; A: Overall accuracy; the values at the right of the TPRs, the TNRs and the accuracies designate the variances.

	Logistic			SMO		
	TNR	TPR	A	TNR	TPR	A
	97,64 ± 0,00	77,67 ± 0,05	95,77 ± 0,00	98,61 ± 0,00	78,43 ± 0,02	96,70 ± 0,00
Cost Sen.	95,81 ± 0,00	82,13 ± 0,02	94,53 ± 0,00	94,85 ± 0,00	86,56 ± 0,01	94,07 ± 0,00
Bagging	97,70 ± 0,00	78,19 ± 0,02	95,86 ± 0,00	98,58 ± 0,00	77,32 ± 0,02	96,57 ± 0,00
CS. w/ Bagging	96,50 ± 0,00	81,64 ± 0,01	95,11 ± 0,00	95,85 ± 0,00	84,81 ± 0,02	94,81 ± 0,00
Info. Gain (8)	98,45 ± 0,00	75,09 ± 0,02	96,26 ± 0,00	98,67 ± 0,00	74,04 ± 0,01	96,34 ± 0,00
(16)	98,46 ± 0,00	77,32 ± 0,01	96,48 ± 0,00	98,48 ± 0,00	77,92 ± 0,03	96,55 ± 0,00
(32)	97,99 ± 0,00	78,28 ± 0,02	96,15 ± 0,00	98,58 ± 0,00	76,98 ± 0,03	96,55 ± 0,00
PCA (8)	98,65 ± 0,00	55,86 ± 0,16	94,64 ± 0,00	99,41 ± 0,00	27,41 ± 0,60	92,65 ± 0,01
(16)	98,66 ± 0,00	74,40 ± 0,01	96,36 ± 0,00	98,80 ± 0,00	72,40 ± 0,00	96,37 ± 0,00
(32)	98,02 ± 0,00	76,11 ± 0,02	95,98 ± 0,00	98,42 ± 0,00	74,92 ± 0,01	96,22 ± 0,00
Boosting	97,70 ± 0,00	77,50 ± 0,05	95,81 ± 0,00	98,06 ± 0,00	78,52 ± 0,04	96,23 ± 0,00
CS. w/ Boost	96,25 ± 0,00	80,79 ± 0,03	94,78 ± 0,00	95,67 ± 0,00	83,11 ± 0,05	94,51 ± 0,00
BoostIG (8)	98,41 ± 0,00	75,61 ± 0,02	96,27 ± 0,00	98,69 ± 0,00	74,82 ± 0,01	96,43 ± 0,00
(16)	98,39 ± 0,00	76,47 ± 0,03	96,34 ± 0,00	98,56 ± 0,00	78,70 ± 0,01	96,69 ± 0,00
(32)	97,64 ± 0,00	77,23 ± 0,02	95,73 ± 0,00	98,01 ± 0,00	77,93 ± 0,03	96,14 ± 0,00
BoostPCA (8)	98,24 ± 0,00	59,66 ± 0,33	94,63 ± 0,00	98,34 ± 0,00	62,85 ± 0,30	95,02 ± 0,01
(16)	98,50 ± 0,00	73,29 ± 0,03	96,14 ± 0,00	98,67 ± 0,00	72,06 ± 0,01	96,17 ± 0,00
(32)	97,88 ± 0,00	75,61 ± 0,05	95,81 ± 0,00	98,34 ± 0,00	75,27 ± 0,01	96,17 ± 0,00

## VITA

Kaya KURU was born in Refahiye, Erzincan, TURKEY on February 18, 1971. His family migrated to İstanbul in 1974. He completed Kuleli Military High School in 1989. He was graduated from the law department in Turkish Military Academy in 1993. He finished a series of lessons of Computer Engineering (OBI) lasting four semesters in METU Computer Engineering Department in September 1998 as a special student of Turkish General Staff. He received his MSc degree in Information Systems from the Middle East Technical University in June 2002. He has been working in GATA as a database administrator and computer programmer since 1998. He is now actively the software programming manager in IT department in GATA. He has been especially studying on applying other sciences into the medical field. His main areas of interest are medical informatics, hospital information systems, artificial intelligence, speech recognition, image processing, modeling/simulation and decision supporting systems.