

DISCOURSE INFORMATION STRUCTURE:
A COGNITIVE APPROACH TO LANGUAGE BASED ON
DYNAMIC NETWORK REPRESENTATION

A THESIS SUBMITTED TO
THE GRADUATE SCHOOL OF INFORMATICS
OF
THE MIDDLE EAST TECHNICAL UNIVERSITY

BY

FIRAT ÖTER

IN PARTIAL FULFILLMENT OF THE REQUIREMENTS FOR THE
DEGREE OF MASTER OF SCIENCE
IN
THE DEPARTMENT OF COGNITIVE SCIENCE

SEPTEMBER 2015

**DISCOURSE INFORMATION STRUCTURE:
A COGNITIVE APPROACH TO LANGUAGE BASED ON DYNAMIC NETWORK
REPRESENTATION**

Submitted by **FIRAT ÖTER** in partial fulfillment of the requirements for the degree of **Master of Science in Cognitive Science Department, Middle East Technical University** by,

Prof. Dr. Nazife Baykal
Director, **Informatics Institute**

Prof. Dr. Cem Bozşahin
Head of Department, **Cognitive Science**

Dr. Ceyhan Temürcü
Thesis Advisor, **Cognitive Science, METU**

Examining Committee Members

Prof. Dr. Cem Bozşahin
Cognitive Science, METU

Dr. Ceyhan Temürcü
Cognitive Science, METU

Assist. Prof. Dr. Cengiz Acartürk
Cognitive Science, METU

Prof. Dr. Deniz Zeyrek Bozşahin
Cognitive Science, METU

Assist. Prof. Dr. Hilmi Demir
Philosophy, Bilkent University

Date: September 11, 2015

I hereby declare that all information in this document has been obtained and presented in accordance with academic rules and ethical conduct. I also declare that, as required by these rules and conduct, I have fully cited and referenced all material and results that are not original to this work.

Name, Last name : Fırat Öter

Signature : _____

ABSTRACT

DISCOURSE INFORMATION STRUCTURE: A COGNITIVE APPROACH TO LANGUAGE BASED ON DYNAMIC NETWORK REPRESENTATION

Öter, Fırat
M.Sc., Department of Cognitive Science
Thesis Advisor: Dr. Ceyhan Temürçü

September 2015, 62 pages

The historical course of linguistics studies with an emphasis on meaning points out the requirement of a representational framework that is capable of forming a structure building bridge between the linguistic (i.e. symbolic) and cognitive (i.e. conceptual) levels. The present thesis aims to lay down some conditions for a comprehensive semantic theory, which is capable of representing all relevant levels of cognitive information involved in semantic processing. This attempt will give rise to a new, suggestive definition of linguistic meaning (semantic structure), as the totality of cognitive information that interrelates the surface linguistic level to relevant cognitive levels during language comprehension and production. Then, a preliminary framework, called Cognitive Information Structure (CIS) is sketched, which provides a representational ground which makes use of dynamically evolving networks. The fundamental properties of CIS are explained and possible theoretical justifications of the framework are discussed. Finally, a representational application of CIS on discourse-syntax level, called the Discourse-Syntactic Structure (DSS) is sketched to represent structural properties of language at the level of discourse. Further elaborations and analyses are left for future research, due to practical difficulties.

Keywords: language, cognition, semantics, representation, network

ÖZ

SÖYLEM BİLGİ YAPISI: DİLE DİNAMİK AĞ GÖSTERİMİNE DAYALI BİLİŞSEL BİR YAKLAŞIM

Öter, Fırat
Yüksek Lisans, Bilişsel Bilimler Bölümü
Tez Danışmanı: Dr. Ceyhan Temürcü

Eylül 2015, 62 sayfa

Anlam odaklı dilbilim çalışmalarının tarihi seyri, dilsel (sembolik) ve bilişsel (kavramsal) düzlemler arasında yapısal bir köprü görevi görebilecek gösterimsel bir çatının gerekliliğine işaret etmektedir. Bu tez, anlama ilişkin bilgi işleme süreçleriyle ilgili bütün bilişsel bilgi düzeylerini temsil edebilecek bir anlam kuramının taşıması gereken koşulları ortaya koymayı hedefler. Bu girişim yeni bir dilsel anlam (anlamsal yapı) tanımı önerecektir: dil anlama ve üretme süreçlerinde dilin yüzeysel biçimini bilişsel düzeylerle ilişkilendiren bilişsel bilgilerin toplamıdır. Daha sonra, dinamik olarak değişen ağlardan yararlanan bir gösterimsel zemin sağlayan, Bilişsel Bilgi Yapısı (BBY) adı verilen genel bir çerçeve sunulacaktır. BBY'nin temel yapısal özellikleri açıklanacak ve bu çerçevenin geçerliliğini destekleyen bazı kuramsal doğrulamalar tartışılacaktır. Son olarak, dilin sözyem düzeyindeki yapısal özelliklerini temsil etmeye yönelik BBY'nin gösterimsel bir uygulaması olan, Söylem-Sözdizim Yapısı (SSY) adı verilen bir gösterim oluşturulacaktır. Daha ileri detaylandırmalar, pratik güçlükler sebebiyle gelecek araştırmalara bırakılmıştır.

Anahtar kelimeler: dil, biliş, anlam, gösterim, ağ

To the sincere passion of the curious mind

ACKNOWLEDGEMENTS

There have been several significant figures that have helped me mold the path on which I endeavor to walk adequately for some time now. Their emotional and intellectual support so far has been a fundamental uplifting force that I've benefited from continuously and in return, there are at least two things that I wish to present: my sincere gratitude and my humble achievements.

Dedicately,

I thank my advisor Dr. Ceyhan Temürcü for being the primary reason of my passion in language, together with his insightful guidance, peaceful spirit and faith in me throughout my graduate years. His teachings have revealed a question that I can pursue for a lifetime with an unending enthusiasm, which is invaluable for a curious mind.

I thank Prof. Dr. Cem Bozşahin for being the other reason of my passion in language and cognition, in virtue of the influence of his seminal knowledge and perspective on me.

I thank Prof. Dr. Orhan Arıkan for his idealism, encouragement and warmth in which I took refuge many times along my undergraduate years. His faith in me has always meant a lot.

I thank Prof. Dr. Varol Akman for his pinpoint and farsighted accuracy while recommending me to apply for a graduate study in cognitive science, based solely on a five-minute speech about my academic interests. Without him, I might still be wandering around.

I thank my dearest friend Ayda Sevin for her unique, timeless and absolute company.

And finally,

I thank my mother, father and sister for always being there for me, whatever it takes. Thank you for being the spring of my inner peace.

Thank you all. I hope I have been worthy of your efforts and expectations. I hope I can continue to be.

TABLE OF CONTENTS

ABSTRACT.....	iv
ÖZ	v
DEDICATION.....	vi
ACKNOWLEDGEMENTS	vii
TABLE OF CONTENTS	viii
LIST OF TABLES, FIGURES AND EQUATIONS	x
CONVENTIONS.....	xiv
PREFACE.....	xvi

CHAPTERS

1. INTRODUCTION	1
1.1 A Brief Investigation on Meaning Theories.....	3
1.1.1 Reference, Proposition, Description and Idea	3
1.1.2 The Empiricist Turn.....	6
1.1.3 Language as a Social and Psychological Phenomenon.....	7
1.1.4 Syntax vs. Semantics	8
1.1.5 The Cognitive Linguistics Turn.....	10
1.2 What History Tells Us.....	13
2. VARIOUS FACES OF BUILDING A THEORY	15
2.1 Theoretical Contrasts.....	15
2.1.1 Syntax vs. Semantics Distinction	16
2.1.2 Dimensionality of Representations and the Meta-Language Dilemma	16
2.1.2.1 The Meta-Language Dilemma	17
2.1.2.2 Linearity vs. Multi-Dimensionality.....	18
2.1.3 Linguistic vs. Non-linguistic Forms of Information	18
2.2 Theoretical Commitments and Conditions.....	20
3. A TWO STAGE APPROACH FOR EXPLAINING SEMANTICS.....	23
3.1 A Multi-Layered Dynamic Network Representation for Language-Related Cognitive Information.....	24
3.1.1 Levels of Analysis and Levels of Information Processing.....	24
3.1.2 How to Represent Levels?	29

3.1.3	More on Dynamicity.....	32
3.1.4	Representation of the Discourse-Syntactic Structure.....	34
3.2	An English Based Exemplification of the DSS.....	40
3.2.1	Verbal Transitive (VT).....	40
3.2.2	Verbal Intransitive (VI).....	41
3.2.3	Prepositional (PP).....	41
3.2.4	Causal Conjunctive (CCA).....	42
3.2.5	Combinatory Conjunctive (CCO).....	43
3.2.6	Temporal Conjunctive (CTP).....	43
3.2.7	Modificatory Qualifier (MQL).....	44
3.2.8	Modificatory Quantifier (MQT).....	45
3.2.9	Modificatory Temporalizer (MTP).....	45
3.2.10	Inheritance (IN).....	46
3.2.11	Possessive (POS).....	46
3.2.12	Sample Discourse Analysis.....	47
3.3	The New Definition of Meaning.....	50
4.	A SELF CRITICISM	53
	FINAL REMARKS	54
	REFERENCES	55

LIST OF TABLES, FIGURES AND EQUATIONS

List of Tables

Table 1. Semantic levels of language processing	26
Table 2. Representation of basic cognitive classes on networks.....	29
Table 3. Representational form of a node in CIS.....	30
Table 4. Representational form of edges in CIS.....	31
Table 5. Representational form of a construct in CIS.....	31
Table 6. Elementary units of DSS ontology together with how they are represented in a dynamic network.....	35
Table 7. Verbs and prepositions in DSS ontology together with how they are represented in a dynamic network.....	36
Table 8. Conjunctions in DSS ontology together with how they are represented in a dynamic network.....	37
Table 9. Implicit modificatory relations and TA in DSS ontology together with how they are represented in a dynamic network.....	37
Table 10. Primitive grammatical constructions in DSS ontology together with how they are represented in a dynamic network.....	38
Table 11. Representing a discourse in a dynamic network, based on the DSS ontology.....	39

List of Figures

Figure 1. The symbolic structural relation between phonology and semantics (p. 8).....	13
Figure 2. The semantic structural relation between linguistic and cognitive levels.....	25
Figure 3. Spatial representation of the semantic structure, including primarily the levels listed in 'Table 1'.....	28
Figure 4. DSS of 'Example 1', demonstrating the representation of VT.....	40
Figure 5. DSS of 'Example 2', demonstrating the representation of VI.....	41
Figure 6. DSS of 'Example 3', demonstrating the representation of PP.....	41
Figure 7. DSS of 'Example 4', demonstrating the representation of PP.....	42
Figure 8. DSS of 'Example 5', demonstrating the representation of CCA.....	42
Figure 9. DSS of 'Example 6', demonstrating the representation of CCO.....	43
Figure 10. DSS of 'Example 7', demonstrating the representation of CTP.....	43
Figure 11. DSS of 'Example 8', demonstrating the representation of MQL.....	44
Figure 12. DSS of 'Example 9', demonstrating the representation of MQL.....	44
Figure 13. DSS of 'Example 10', demonstrating the representation of MQT.....	45
Figure 14. DSS of 'Example 11', demonstrating the representation of MTP.....	45
Figure 15. DSS of 'Example 12', demonstrating the representation of IN.....	46
Figure 16. DSS of 'Example 13', demonstrating the representation of POS.....	46
Figure 17. DSS of the first sentence of the discourse, or the initial state of the dynamic network, i.e. 'state i'.....	47
Figure 18. DSS of the first two sentences of the discourse, or the second state of the dynamic network, i.e. 'state 1'.....	48

Figure 19. DSS of the first three sentences of the discourse, or the third state of the dynamic network, i.e. ‘state 2’	48
Figure 20. DSS of the first four sentences of the discourse, or the fourth state of the dynamic network, i.e. ‘state 3’	49
Figure 21. Complete DSS of the discourse, or the final state of the dynamic network, i.e. ‘state f’	49
Figure 22. Local and dynamic meaning in a sample CIS, based on a three state semantic structure	51

List of Equations

Equation 1. The definition of dynamic meaning, M_D , as a function, F_T , of local meanings, M_L 50

CONVENTIONS

Type Setting

Standard conventions are used for text enhancement; but various additional type settings are also defined.

CAPS	:	Labels; abbreviations
<i>italics</i>	:	Terms and concepts defined or introduced within the work; terms and concepts inherited from other works; works of other authors; emphasis on examples, terms, concepts and phrases
‘single quotes’	:	Sections within the work; figures, tables and equations; emphasis on named entities
“double quotes”	:	Quotes from other works

Symbols and Abbreviations

CIS	:	Cognitive Information Structure
DSS	:	Discourse-Syntactic Structure
SoA	:	State of Affairs
TAM	:	Tense, Aspect and Mood
TA	:	Tense and Aspect
Ann _{DSS}	:	Annotated w.r.t DSS Ontology

Glosses

The main gloss used within the work is the Cognitive Information Structure tag set that is generated for annotating ontological and topological elements, relations and structures of various domains with respect to the theoretical requirements and claims of the CIS framework.

CCA	causal conjunctive relation
CCO	combinatory conjunctive relation
CP	conceptual element
CPS	conceptual set
CTP	temporal conjunctive relation
E	edge
E _S	self edge
E _R	relational edge
E _{IR}	inter-relational edge
E _{SR}	self-relational edge
ID	identity relation
IN	inheritance relation
N	node
C	construct
MQL	qualifying modificatory relation
MQT	quantifying modificatory relation
MTP	temporalizing modificatory relation
N _C	(abstracted) construct
NEG	negating relation
POS	possessive relation
PP	prepositional relation
RF	referential element
S	discourse structure
SP	specificity relation
VT	verbal transitive relation
VI	verbal intransitive relation

PREFACE

For any one, whom pursuit is to explore and understand the true character – if there is any – of nature, there lie uncountable paths to follow. However a person with such a purpose should clarify the initial motivation first, in order to choose one of those correct paths that bear the potential of leading him to success. The statement above may seem vague and more probably trivial for most instances of scientific survey. Yet when the problem at hand is already complex enough to surpass not only what we already know about nature or the capacity of tools we developed for the sole purpose to discover, but also the intuitive and creative power on which we rely on so much, then we must answer initially this question: What may be the most comprehensive perspective one can develop to achieve the ultimate resolution into the problem, through which the problem is finally explicit enough to enable a potential answer? The answer to this question lies simply within two different parameters: the expectancy of the scientist and the complexity of the problem. The convergence between these two domains – the realm of the scientific mind and the realm of the problem – finally defines the path on which the scientist will begin his journey and molds the underlying fate ultimately. In that case, to pick the promising one out of an infinitely large set of possible convergences is clearly the foremost requirement that all members of scientific society shall agree on and embrace with sincerity, if we ever wish to claim an answer on various questions that lies on and beyond the boundaries of science.

In 1974, Richard Feynman gave his famous speech *Cargo Cult Science* and regarding the context so far, I admit the core of it is still deeply relevant. Leaving aside the problem of integrity by a hopeful assumption that modern science is pretty much over it, there is still the problem of freedom that functions against the progress of scientific knowledge. Independent of the question at hand, the scientist eventually decides his means to investigate it, but obviously in relation with various limitations. Most of the time these limitations are parallel to the desired outcome and thus are expected limitations by being accepted from the beginning. However, if the desire that drives the survey is concerned with technical matters more than the sincere passion of the curious mind, it is inevitable to miss certain achievements. As the intersection of science with technology gets more and more intricate with every passing day, institutes of science are merging with industry faster than ever. This marriage of constitutions does obviously have its benefits, but theory and practice do not always work smoothly together and when they do not, it is important which side is favored. It is always crucial not to forget one of the fundamental purposes of science if not the most, which is revealing the unknown with utmost precision. Such an attitude may help when the problem in focus prevails much longer than it is expected from it.

CHAPTER 1

INTRODUCTION

Modeling meaning is a central topic in linguistics and cognitive science, because it bears crucial importance for understanding cognitive aspects of language, including high-level cognitive processes such as information representation, categorization and manipulation. In order to investigate this topic, one may take several different stances and perspectives due to the multi-faceted nature of the relation between linguistic form and meaning. I assume that this relation is reducible to an information processing problem, such that meaning *is* the totality of cognitive information manipulation processes performed on cognitive information¹ structures within the configurational boundaries set by linguistic expressions. Hence, the most appealing strategy towards understanding linguistic semantics would be to approach the inquiry from a generalist point of view that aims to connect various related theories and findings from different scientific areas, primarily cognitive science, linguistics, AI and philosophy.

The reduction of semantics to an information processing problem is grounded by three main assumptions: (i) language is purely symbolic; it does not encapsulate meaning as distinct entities, but only provides instructions that guide cognitive processes, (ii) information content – meaning – symbolized by language is generated by cognitive mechanisms acting upon cognitive information structures, and following from (i) and (ii), (iii) meaning is linguistically representable – to a limited extent in line with communicative requirements –; but only cognitively realized. Moving from here, for modeling language without excluding semantics² we need at least two answers: (i) how the structure posited by language that corresponds to cognitive information structures and their inter-relations can be mapped into a representational medium of analysis and (ii) what is the nature of cognitive information above which meaning emerges.

In order to go into these questions, one needs to be clear about what cognitive levels of processing are involved in language production and comprehension. Although traditionally the surface form of language is taken to span phonology and syntax, this thesis takes these to be

¹ The term *information* is used here to denote the components of cognitive constructs which constitute some form of knowledge.

² In the scope of this thesis, some core words such as *semantics*, *meaning* and *linguistic meaning* are used interchangeably – in line with the literature –, if the local context of their use does not enforce otherwise.

cognitive levels as well. The rationale is that the only purely external aspect of language is the phonetically, orthographically, gesturally or otherwise realized signal. As soon as one starts to recognize phonemes, let alone morphemes and lexical items, one is in the domain of cognitive categorization and delimitation. So, the real surface form of language is the external, symbolic form. All other levels of language are cognitive, hence part of the semantic structure. These involve phonological, morphological, syntactic, referential and inferential processes, just to name the basic ones. While many existing semantic theories and frameworks put emphasis on one of these levels of information processing, this thesis proposes that linguistic meaning resides in all these levels; encompassing parallel processes at every relevant cognitive level.

The theoretical framework in this thesis adopts a two stage-approach that is expected to provide a fruitful scientific methodology for exploring the true extent of semantics in terms of language-cognition relation: (I) building a network topology for representing the syntagmatic structure of language at discourse level, and (II) building a cognitive ontology that spans all possible cognitive primitives, elements, relations and compounds that relate to language processing. (II) is believed to be an extremely difficult goal for scientific inquiry to achieve and thus to be covered by a single thesis, because its origins are beyond language, multi-dimensional in terms of the cognitive mechanisms involved and multi-layered in terms of the cognitive levels involved. Still, this thesis will provide an outline as to which levels of information processing may be relevant at this stage, and make some representational suggestions. As to details, (I) will be prioritized in order to conquer a common base ground on which (II) can be anchored, tested and more importantly understood.

The thesis is divided into four chapters. The present chapter, Chapter I, includes two introductory sections: 'Introduction' explains how the thesis aims to develop a novel framework for modeling semantics from a cognitivist perspective. 'A Brief Investigation on Meaning Theories' reviews past and recent attempts to understand and formalize linguistic semantics. Chapter II is preliminary to Chapter III, including various sections required to establish a well-defined ground for building up an adequate semantic theory. The preliminary requirements are clarified for structuring a theoretical framework: 'Theoretical Contrasts' standing for the opposing theories or perspectives on certain foci of semantics (including the friction between generative vs. cognitive linguistic views on modeling language and different views on syntax vs. semantics distinction), and 'Theoretical Commitments and Constraints', standing for the fundamental assumptions of the theoretical perspective taken by this work and major bottlenecks that are believed to limit any scientific survey on semantics. Right after setting the ground, Chapter III introduces the core work of the thesis, that is, the Cognitive Information Structure (CIS) framework. The chapter is divided into two progressive sections. First part explains a two-stage methodological approach adopted for attacking to the core problem and then continues with the second where elements of the discourse-syntactic structure (DSS) are introduced. Then DSS oriented analyses of some linguistic examples are presented. The thesis closes with a final chapter, Chapter IV, which includes a self-criticism of the model from both theoretical and practical aspects. This is followed by an epilogue on final remarks.

1.1 A Brief Investigation on Meaning Theories

Any theory that attempts to propose an explanation on how language relates to meaning should primarily consider two main facts: (i) the language-meaning interface has quite a long history of various perspectives that have elaborated in the direction of both divergent and convergent depths and (ii) the problem at hand actually seems to require various levels of analysis, each of which is expected to reveal related characteristics of the phenomenon. In that regard, this thesis essentially prioritizes a comprehensive analysis of why semantics is a central topic in linguistics, in what ways the pursuit of understanding meaning generated countless problems, how this overall enterprise branched into many specific focuses and finally where on this wide spectrum of perspectives, theories came together naturally and formed collaborative clusters.³

A brief examination on language reveals that linguistic expressions are formed by atomic units that one way or another point to apparent elements of worldly state of affairs (SoAs). The key relation in this simplistic description is *reference*, such that units of expressions demonstrate some relation to some entity or relation in the world, by dint of being symbolic in nature. One may ask here why language should involve meaning in the first place. But in 1840s, when the moving force of sciences, philosophy, had founded itself upon the explanatory power of natural languages, the assumption that language must have an inherent link with meaning was not only evident, but also required due to the fact that the only accessible path, which leads to language was meaning in the first place. Accordingly, *meaning* has always been central to any approach to language, and its foregrounding as due to the attempts of understanding how language works, is namely, the *theories of meaning*.

1.1.1 Reference, Proposition, Description and Idea

One of the first major meaning theories in history is the *Direct Referential Theory* (Mill, 1843). Although a primitive approach, it initiated a whole new era on studies, which take language as a natural phenomenon. What the referential theory basically proposed was that language can be described at the sentence level as being composed of words, and that these words are in a direct referential relation with things in the world. In that regard, the meaning of a word was conceived directly as its referent. The emphasis on the symbolic nature of language and the dominance of extra-linguistic context in meaning were the significant ideas of the theory. Several objections to the theory were made in the late 19th century that deepened the discussion, when linguistics experienced the structuralism turn (of which Ferdinand Saussure, Roman Jakobson, Gottlob Frege, Ludwig Wittgenstein and Bertrand Russell were some leading figures) that favors the descriptive analysis of language.

Three main objections were made to referential theory:

³ The following investigation on the historical progress of meaning theories is not only a brief summary of historical facts, but also includes respective commentaries in line with the author's subjective perspective on language-semantics interface. For more information on the theoretical commitments of this thesis, please refer to the section 'Chapter II – Theoretical Commitments and Conditions'.

- i. Not every word refers to a real, existent entity (e.g. ‘the One Ring’).
- ii. A sentence is not a mere list of words, but it exhibits structure (e.g. ‘a misty day’).
- iii. Varying expressions of the same referent also varies in meaning. (e.g. ‘Earth’ vs. ‘the green planet’)

All these three examples, apart from being apparently solid objections, raise two main and valuable insights about the nature of the track that semantics within language studies would follow: (i) there should be semantic levels that reside between linguistic expressions and their referents and (ii) language is compositional, and so should be meaning. Moving from the objections (i) (i.e. the problem of apparent reference to nonexistent) and (iii) (i.e. the problem of substitution), Frege (1892, 1979) and Russell (1905, 1911, 1919) proposed various solutions. These considerations stipulated more comprehensive ontologies of entities that symbolic language links to semantically. One important attempt in this direction was Frege’s *sense* (1892, 1979). Even if the notion was unclear, it was crucially important by being a semantic abstraction from language. In Frege’s framework, senses, which include propositions, are logical entities that are both language-independent and subject-independent. In detail, they correspond to abstract entities that reside in a domain of possible meanings. Getting back to objection (i), in Frege’s solution that is based on a logical conception of language, sentences which mention nonexistent referents will not lend themselves to any logical analysis, and hence will not have any truth-value. In other words, they will be meaningless. However, such a result was not favorable, because regarding any subset of linguistic expressions meaningless seemed contradictory with the very nature of language, the primary property of which was meaningfulness. Later a workaround was proposed by Russell in that direction by paraphrasing expressions including singular terms corresponding to nonexistent entities (e.g. Pegasus) into expanded expressions including logical operators (e.g. quantifiers) and conditions (e.g. uniqueness) applying on those terms. By this strategy, it finally became possible to analyze expressions which involve terms with non-existent referents logically, yielding False as their semantic value.

According to Russell and young Wittgenstein, logic – by being the structural essence of all natural phenomena – should be the systemic ground beneath language, and thus linguistic expressions can be translated into logical propositions. Russell and Moore (Ramsey & Moore, 1927) had little or none to say about what propositions actually are, but instead they showed how they function within their theoretical frameworks. However such attempts of generating abstract, higher-level forms of information for explaining meaning were important to validate the necessity of a language-independent ontology for semantics. The logic assumption also provided a partial answer to (ii) by showing how linguistic meaning can be compositional. If the compositional properties of an expression changed, the corresponding proposition would be of different structure, which could yield a different truth-value.

Another major descriptive proposition was made by Russell (1905, 1911), with a focus on the true referent of proper names. In the linguistic epistemology of Russell, proper names are assumed to be *definite descriptions* in disguise. This definition entails that proper names are actually symbolic place holders in the domain of language those map into the descriptions via logical analysis, representations or relations lying in the domain of semantics. The mapping relation in mention is one of the first insights that claim a fine distinction between the surface form of language and its meaning, where informational content is attributed to the latter. Nevertheless, when the relativity of speaker is concerned based on a context-dependency

approach, the link between a name and a description is not one-to-one and static, since every speaker accesses to a different domain of knowledge. This phenomenon is explained by *knowledge by acquaintance* in Russellian epistemology, such that any truth-verifiable knowledge is acquired only by the unique interaction of an agent with his external context, which yields a corresponding experience that is accessible only by the agent himself. If, however, the information is inherited indirectly from an expression; but not from the world directly, then the corresponding knowledge will be *by description*, such that the host is unable to make a truth-conditional justification. Later, a language-oriented elaboration that can be related to this distinction was introduced by the *Cluster Theory* (Searle, 1958), which claims that in order to assume referring to a referent by its name is useful in terms of communicational efficiency, one should presuppose that certain characteristics of the referent should be publically accessible. In relevance, a name is initially associated with a vague cluster of descriptions, from which a definite subset of description is called in line with the contextual instantiation of the name. However it is, understanding referents as context-dependent descriptions is a step forward attributing the meaningful content of linguistic expressions a complex structure, which would later be a core assumption in the detailing of cognitive correlates of meaning.

The logical translation of language was indeed a revolutionary idea in virtue of granting linguistic studies a formal meta-language, but equating linguistic meaning with truth-conditions was subjected to many objections. According to Strawson (1950), ‘sentences express propositions’ was not a fruitful statement, because sentences may have semantic values other than just True or False. The rejection of truth-value as the ultimate answer to meaning was supported by linguistic evidence, such as the introduction of the *Speech Act Theory* by Austin (1975) and Searle (1965). What is special about these approaches is that they placed importance on the performative character of language: a special subset of linguistic utterances, *performatives*, was famous in being not truth-evaluable.

Moving back to the mental conception of meaning and to put an emphasis on why such a perspective is important for providing comprehensive cognitive ontologies, it may be necessary to have a short glance at the *Ideational Theory of Meaning* (Locke, 1690/1975) and its derivatives. The essence of the perspective is this: the meaning of a linguistic expression is a mental state, a mental image or simply an *idea* of a language user. It is interesting to see how such a primitive intuition prevailed through more than three centuries and became – yet again in essence – one of the primary assumptions of cognitive linguistics and also this thesis. Similar to the perseverance of this idea, major counterarguments against it also showed great resistance to time and thus deserve a brief mention. The first and foremost objection is based on the nature of cognitive constructs: The definition of *idea* (or, concept) is not clear, it is highly abstract and not testable. This criticism is also usually made against cognitivist accounts for semantics. Even if cognitivist claims cannot exactly define the character of cognitive elements involved in linguistic meaning (e.g. ideas, thoughts, mental images, mental representations etc.), the search for purely cognitive entities is an obviously reasonable attempt since language is produced and interpreted in cognitive systems.

The second objection concerns special subsets of linguistic categories: many lexical classes in language, such as function words (e.g. ‘is’, ‘and’, ‘of’) do not have imagistic or ideational counterparts in the mental space. (ii’) This is again a weak claim due to the hidden assumption that the cognitive information corresponding to linguistic categories are all at the same level,

thus characterized by the same means. Cognitive processes exist at various levels which involve several different aspects, different levels of abstraction and different degrees of complexity. For example visual cognition is a general cognitive mechanism, which acts upon different domains of information (color, depth, light intensity, perspective, contour, shapes, lines, facial features etc.). These domains are of various complexity, operations in them trigger different mental processes and activates the neural hardware in various different ways. This may be the case for different linguistic categories as well, some being processed by more complex mechanisms governing various levels of cognitive information while others do not.⁴

The third main objection is related to the pragmatic nature of language. (iii) Meaning is a publically accessible social phenomenon that is shared among subjects of the same linguistic community. On the contrary, ideas, images and mental states are within the subject's mind and are not intersubjective. (iii') This assumption will lose its force in consideration of the subjective relativity of linguistic meaning. Pragmatic notions such as ambiguity and speaker's (intended) meaning are at the core of many psycho-linguistics studies, which all goes beyond the assumption that semantics consists only of social conventions.

There are of course various other objections in addition to the ones stated above, but the fundamental conflict that the assumption of abstract semantic ontologies in form of cognitive representations conceives is based on the natural difficulty of their verification. This is why, the logical empiricist turn in 1930s adopted a purely logic based formal approach to language and its relation to meaning.

1.1.2 The Empiricist Turn

With the effect of Wittgenstein's (1922)⁵, Russell's (Cocchiarella, 1997; Hager, 1994) and Carnap's (1931, 1937/2002) logical atomism on western philosophy of the early 20th century, logical empiricism began to flourish and seize the scientific minds of the era. Dividing every natural phenomena to their logical parts became the main pursuit of empirical sciences. This, of course, was also valid for language studies and around 1930s, the core of logical positivism showed itself in linguistics as *The Verification Theory* of meaning. According to the theory, a linguistic expression is meaningful by virtue of the experiential verification of a language user. This assumption is, of course, valid if the sentence can be identified as true or false in the first place. Obviously, such a reductive model of meaning did not brought forward much innovation as compared to similar attempts of reducing language to its assumed pure logical form. Whatever its success on modeling language is, logical positivism helped scientific enquiry evolve into modern positive sciences and enhanced the model theoretic paradigm in linguistics.

Right after the verificationist blow over meaning theories, Davidson (1967, 1970) reverted back to the less ambitious attempt of formulating *truth conditions* for linguistic statements. Different

⁴ See, e.g. Talmy (2000a, 2000b) and Evans (2009), which posit different subsystems for lexical and grammatical elements.

⁵ Wittgenstein later rejected some of his views in his *Philosophical Investigations*.

from the verification method that looks for evidential correlates of the linguistic expression in real-time, these are conditions for a statement to be true. With the use of Tarski's (1944) *biconditionals* (T-Sentences), Davidson's attempt of mapping linguistic expressions to their truth-conditional counterparts found itself a formal ground, which can be counted as a proper theoretical fill in. Later, Kripke (1971, 1975, 1977, 1980) introduced the notion of *possible worlds*, which defined broader sets of conditions. In association with the conditional nature of any target world, an expression could yield different truth values. Such an approach added some flexibility to the truth-conditional approach that is more in line with the expressive power of language and answered various problems of Davidson's program. However, being again a logical reductionist approach to language and moreover putting truth in the center of the framework, the theory faced objections similar to those raised against truth-conditional and verificationist theories.

1.1.3 Language as a Social and Psychological Phenomenon

In mid-20th century, Ludwig Wittgenstein (1953/2010) shifted the focus on meaning from abstract entities or propositions to social rules and conventions. Austin (1975) later developed the social account for linguistic meaning, but the core of *use theories* of meaning remained largely as a Wittgensteinian view. Moving from Wittgenstein's *language games* that put an emphasis on the social function of language, in the theory, linguistic expressions primarily function as instantiations of social interaction between communicating agents. Accordingly, the meaning of those expressions should be described based on which social occurrence that they trigger, instead of which proposition that they refer to. There were three main objections to the view that elaborates on the idea that meaning can be defined in terms of its social conventional *use*:

- i. The rule based, strictly conventional definition of meaning cannot explain the highly fluid and relative nature of linguistic meaning.
- ii. Many non-linguistic conventional, rule based mechanisms involved in social activity do not have a complex meaningful character that language inhibits. Language should involve more to social conventions and rules.
- iii. The theory does not have any cognitive account for language.⁶

Use theories may have failed to provide an adequate base for modeling language, but gave many insights to pragmatic and psychological studies of language by putting humans, as social entities, in the center of the theory. The psychological account for language proposes that linguistic expressions are meaningful, primarily because they directly express the psychological states of the speaker. Starting from this, Grice (1957, 1969) brought forward a new definition for meaning that is essentially tied to the beliefs and intentions of the speaker, the *speaker meaning*. This novel definition was actually a return to mental conception of meaning, and what Grice

⁶ The motivation of the use theories is similar to the postulates of behavioral psychology bank back in 1950's, which was eventually replaced back with experimental psychology that later became one of the primary building blocks in the birth of cognitive science.

specifically tried to achieve was to model meaning upon pure psychological states. What speaker meaning basically corresponds to is that when the speaker utters a sentence, what s/he actually does is to convey a belief to an audience, with a definite intention. So, apart from the sentence (i.e. linguistic expression), with the addition of belief, intentions and audience to the equation of meaning, what Grice did was actually to take mental forms of information (belief), higher level mental states (intentions) and the context (audience) into account while modeling meaning. In that regard, speaker meaning includes an early cognitivist perspective that supposes a context-dependent cognitive ontology. The basic ideas that Gricean theory of meaning assumes are adequate regarding the necessity of a comprehensive and generalist point of view to understand the relation between language and meaning, but in practice the theory could not show its full potential due to several reasons, primarily the lack of a language-independent medium (e.g. formal or informal) to express meaning and a useful cognitive (or psychological) ontology.

When Grice spoke about a relative conception of language from the speaker's perspective, Austin (1975) elaborated upon the idea and selected a special subset of possible linguistic utterances, *performatives*. The examples of this class show the property of directly expressing the speaker's immediate speech act. In that respect, they put up a resistance against propositional logic and its classical truth-conditional approaches, which have always been found problematic in penetrating such ends of language⁷. Later, Austin decided that not only performatives, but all declarative sentences involve *illocutionary force*, which encapsulates the intentional content of the speech act. Moreover, the speech act does extend beyond the speaker and conveys various effects on the hearer as well, via a secondary intrinsic feature, the *perlocutionary force*. Finally, the theory does not reject the contribution of propositional or descriptive content that eventually adds up to linguistic meaning. All these taken into account, speech act theory stands alone as one of the first theories of meaning that takes language as a multi-level phenomena and works upon it by a levels of analysis approach. Austin took language in hand from a pragmatic and psychological perspective and as an answer to the era's 'true/false fetish', he introduced the *felicity conditions* that are similar to truth conditions in motivation, but differs in flexibility and ambiguity by favoring the dynamicity of context-dependency and mental phenomena. In the following era, pragmatic and psychological accounts for language increased in number by the introduction of many working concepts and theories such as *implicatures* and *conversational relations* (Grice, 1975) and *Relevance Theory* (Sperber & Wilson, 1986). In spite of the common objections against them, their perseverance within the field eventually contributed to the gradual distinction within the study of linguistics simply based on the question whether to involve cognition in the equation or not. One answer to that question finally gave birth to a purely cognitivist and semantics oriented perspective to model theoretic approaches on language, namely cognitive linguistics.

1.1.4 Syntax vs. Semantics

It is essential not to forget (before moving to cognitive linguistics) that after late 1950s, Chomsky's program of generative linguistics started to take major steps in modeling surface

⁷ To fill that gap, Searle and Vanderveken (1985) introduced a special adaptation of logical analysis, *illocutionary logic*, which provided an exploratory medium for speech acts to be logically represented.

language by limiting the problem only to syntax, which is especially interesting knowing today how a purely syntax-oriented movement has generated its own semantic approaches that later contributed to parallel efforts in other perspectives. In its early years, the Chomskyan (1956, 1965, 1975) syntax-oriented approach started to define a major paradigm in language studies, by virtue of disregarding any implicit or abstract entities that have been theorized in order to understand language via traditional semantics. Chomsky added a new level of analysis to language, which is morpho-syntax, and left other questions to other fields. With the addition of syntax, linguistics was divided into at least three distinct levels: *semantics* that deals with the ontology of linguistic elements those contribute to meaning, *pragmatics* that deals with the contextual and psychological aspects of language use and finally *syntax* that deals with revealing the surface structure of language, namely its compositional properties. Nevertheless, it will not be historically precise to think that the apparent distinction occurred between syntax and semantics (pragmatics has been relatively irrelevant to the friction between those two) was a peaceful and commonly accepted one. According to Chomsky (1975), the pursuit of an adequate answer to meaning is of course central to linguistics, but the emphasis should be taken from a traditional semantic approach to be granted to a syntactic one:

“I will merely emphasize again that the legitimacy of semantics (whatever that might mean) has never, to my knowledge, been challenged, nor has there ever been any question of the importance of incorporating a study of reference, meaning, language use, and related topics within a full theory of language that will deal, in particular, with the highly significant relations between formal structure and semantic interpretation. The appeal to meaning must be clearly distinguished from the study of meaning. The latter enterprise is unquestionably central to the general theory of language, and a major goal of the *SS-LSLT* approach is to advance it by showing how a sufficiently rich theory of linguistic form can provide structural descriptions that provide the basis for the fruitful investigation of semantic questions.” (p. 21)

All in all, Chomsky’s skepticism at that time about the traditional school of semantics, and the resulting wish of isolating language studies from a semantic perspective was not enough to bound generative school in that direction. When semantics in form of curious questions and following attempts on understanding meaning began to emerge within the context of generative grammar, it became impossible to evade discussing syntax-semantics interface (Partee, 2014).

The first major introduction of semantic formalization within generative linguistics was the emphasis on compositionality (Katz & Fodor, 1963) in surface structure and the division of syntactic analysis into two levels (Katz & Postal, 1964): *surface level* that underlies phonology and *deep level* that underlies semantics. An objective evaluation upon this separation can yield a fair conclusion that even generative approach based on syntactic evaluation felt the necessity of an abstraction from surface in order to work better with semantics, or linguistic meaning. This later caused opposing fronts in the school based on how semantics should be treated within generative approach: *Generative Semantics* (Lakoff, Postal, Ross) defended the need of going deeper in structure by increasing abstraction until it is sufficient, against *Interpretive Semantics*, foundations of which was laid by Montague (1970, 1973). What interpretive semantics suggested was simply that syntax and semantics are both algebraic systems, and semantics can be obtained from syntactic rules by means of domain transitions. In other words, semantics is an *interpretation of syntax* and what is necessary to achieve is not an abstraction from syntax, but revealing the morphisms that are required for the mapping between syntax and semantics. The

idea was indeed insightful, proposing that moving from the level of syntax and using its compositional properties, one can start to model semantics by straightforward algebraic transformations. However, despite the emphasis on syntax in interpretive accounts for semantics, Chomsky remained skeptic to such attempts since syntax is never the core explanatory tool for semantic theories, even if they were born within the generative view. It is better to leave the question of why Chomsky and his purely syntactic movement stayed that way to historians of science, but one point is very clear that with the help of generative movement at least two significant theoretical achievements were made: syntax is accepted as a solid level of analysis in linguistics that revealed a substantial amount of facts about the surface structure and semantics oriented surveys within the school inevitably generated a fruitful syntax-semantics interface, even if both domains are independent and the interface is highly complex (Jackendoff, 2003).

1.1.5 The Cognitive Linguistics Turn

George Lakoff, being a former generative (1970, 1973) and a latter cognitive semantician (1987a, 1987b, 1992, 2008; Lakoff & Johnson, 1980a, 1980b, 1997) is a good example of how the necessity to deal with meaning has never abandoned the historical course of linguistic studies. Together with the breakthroughs in pragmatics, discourse studies, psycholinguistics studies (e.g. language acquisition), lexical semantics and formal linguistics (e.g. generative linguistics and formal semantics), another major perspective was slowly coming into view, which would later be named as cognitive linguistics. When we investigate studies on semantics in the 20th century, it is possible to detect many insights about how mental faculty of man shapes meaning; yet most of these were overcautious. Science had gone through logical empiricism, which slowly built a high political authority above all fields and an imperative skepticism over speculative abstractions. Due to apparent reasons including lack of proper apparatus and methodology, the brain and the mind had not passed the threshold yet to free themselves from the infamy of metaphysics until the end of 1950s, when cybernetics and consequently the *cognitive revolution* (Miller, 2003) came to stage. Yet, it took another ten to twenty years for the cognitivist perspective to become a mainstream approach within linguistics, allowing scientists to come up with explanatory frameworks for semantics and language upon cognitive mechanisms, states, representations and abstractions. When we examine the major theses on cognitive linguistics – impacts of which are still highly visible and influential –, it looks like there have been a solid breakthrough especially in early 1980s, starting with the *framing* theory of Fillmore (1982, 2006).

In relation with extensive studies on polysemy, contextual variation, metaphor and metonymy, the inherent flexibility of lexical elements became a serious problem for modeling meaning via formal approaches. It was not possible to include such ends of language to frameworks without utilizing adequate mental ontologies beyond language. Frame semantics was an effort in that direction, positing context-dependent classes of information, namely *frames*. According to Fillmore, it was not possible to attach meaning to linguistic units (words, or more complex expressions) atomically and in isolation, since they are semantically tied to many other forms of context-dependent and encyclopedic information. An interesting point of the theory is that, linguistic units do not only inherit informational content from their semantically related

neighbors or parents (e.g. *vehicle, car, wheel* for *drive*), but also structural properties from their syntactic context (e.g. *driving something to somewhere* for *drive*). In that sense, frame semantics assumes context-dependency not only at the conceptual, but also at the surface-compositional level. Even if the exact relation between syntax and contextual experience is not clear, it was important at least to claim that linguistic structure was sensitive to context, since syntax plays the primary role for formal conceptions of language.

In light of the revolutionary categorical classification of entities, namely, *prototype theory* (Rosch 1975a, 1975b, 1978), various elaborations based on *frames* followed one after another, introducing a hastily expanding and interestingly coherent universe of accounts to meaning. Due to its broad implications and wide usage within cognitive semantics (Geeraerts, 1989), prototypical classification of concepts, sometimes based on a family resemblance approach, started to be a central feature for explaining polysemy and vagueness (Croft, 1993; Fauconnier, 1997; Fauconnier & Turner, 1998; Gärdenfors, 2000, 2004; Lakoff, 1987b, 1992; Langacker, 1986, 1987, 1991; Tuggy, 1993). *Radial Network* model⁸ is a major example of a semantic ontology based on prototype theory. Here a category is more or less conceived as a circular (or spherical) entity, center of which is often the prototypical instance (sense) and other instances of the category radiate from the center according to their degree of their semantic similarity to the center or to other elements. The *schematic network* model (Langacker, 1986, 1987) is also similar to radial networks, but it adds dimensional complexity to categories: at each hierarchical level within a category (or between categories, which are clustered by a superordinate one), prototypical properties that underlie the category also vary in complexity along a taxonomic dimension, e.g. in respect of specificity or vagueness (Tuggy, 1993).

Metaphors have always been an interesting focus of linguistic study. Especially for formal semantics and generativist approaches, it was nearly impossible to reduce metaphors on atomic linguistic levels and to grant them a well-defined lexical form. *Conceptual Metaphor* theory (Lakoff, 1992; Lakoff & Johnson, 1980a, 1980b) was one of the first popular cognitive approaches to metaphors, nullifying all attempts of formalizing metaphors in surface language level by the assumption that metaphors are not lexicalized linguistic units with strict borders, but instead they act as cognitive mechanisms that allow mapping relations between *domains* of cognitive information. Such an explanatory approach to cognitive semantics, not only at the level of cognitive ontology but also at the level of cognitive processes, has been indeed pretty impactful, anchoring the use of the terms *concept, domain* and *construal* (Langacker, 1986, 1987) as central terms for any theory of cognitive semantics. The *image schemata* model (Johnson, 1987) went hand in hand with the conceptual metaphor theory to introduce very fundamental conceptual primitives on which concepts and domains can be grounded. According to the explanation, image schemas are very basic semantic structures, which have prototypical properties in relation with fundamental physical experience, such as *path, scale, containment* and *balance*. Image schemas set a base for semantic structures, upon which concepts and domains of various complexities emerge. Later it was argued by some that image schemas are actually special types of domains (Clausner & Croft, 1999), special in virtue of their position within the taxonomic order of domains. One recent example of image schematic approaches is the theory of *anchoring relations* (Temürücü, 2007, 2011), which provides a semantic space for

⁸ A linguistic case study of radial networks based on the use of *over* in English, by Brugman and Lakoff (1998), is a good informative example of how such ontologies are exemplified via linguistic analysis.

tense, aspect and mood (TAM) markers via three hierarchically interrelated domains, namely *temporal*, *epistemic* and *volitional* domains. It insightfully apprehends close similarities of configuration among these three domains, which may be an indication of an implicit, basic element – may be a path image-schema – contributing eventually to internal structures of the domains that it sources.

Having a fairly rich conceptual ground at hand, it is also essential to focus on the software that governs the internal processes and relations of our semantic space. Domain relations are such processes, and *Mental Spaces* (Fauconnier, 1985) together with *Conceptual Integration Networks* (Fauconnier, 1997; Fauconnier & Turner, 1998) are comprehensive explanations based on descriptive analyses of how dynamic mental spaces map to each other by semantic links. The theory assumes four main spaces: *input space*, *output space*, *blend space* and *generic space*. Generic properties of the input space are projected onto the output space in relation with the required semantic associations, which generates a new blended space, having identificational links to both input spaces. It may be necessary to note that what Fauconnier proposes is not limited to metaphoric domain mappings, but a general explanation of domain transitions in form of *conceptual integrations* that is concerned with the dynamics generated by the co-occurrence of multiple domains in the same semantic process.

Conceptual Spaces (Gärdenfors, 2000, 2004) is one of the latest attempts that elaborates on a comprehensive description of the cognitive semantic ontology, via a purely topological approach, in which the conceptual space is defined as a multi-dimensional space consisting of *points* denoting *objects* (conceptual instantiations) and *regions* denoting *concepts*, the value of which are determined by their relative vector definitions. Such approaches are of course relatively more difficult to validate in empirical means as compared to those avoiding to go beyond the symbolic level. However, they gain support from embodied cognition perspective, which claims that high-level mental representations are formed analogously on the basis of perceptual imprints (e.g., Barsalou, 2008).

Corpus-based studies as well as other experimental and data-driven approaches define a new paradigm in cognitive linguistics. It is obviously promising to see that through the lens of a cognitive focus on language with semantics in center, the overall enterprise has found its ways to link with other major scientific fields such as statistics, topology and natural ontology. This fortunately freed cognitive semantics from dwelling in its own wild abstractions by making intelligent use of already existing frameworks, some of which has already embedded itself empirically into various fields of applied sciences.

Apart from the cognitive semantics accounts, there have been several major ventures of revealing possible links between grammar and cognition as well (Fillmore, 1988; Goldberg, 1992, 2006, 2009; Goldberg & Suttle, 2010; Lakoff, 1987b; Langacker, 1986; Talmy, 1988a, 1988b). The primary effort in this class is Langacker's *Cognitive Grammar* that studies how morpho-syntactic properties of language contribute to meaning, and vice-versa. The main idea beneath his account of grammar is that form (expression) and meaning (cognitive information) are not distinct, but interrelated phenomena co-occurring simultaneously in symbolic structures. The theory does not only account for lexical items, but secures a description of grammar that demonstrates compositionality. In *Dynamicity in Grammar*, Langacker (2001) schematically illustrates the structural relation between linguistic and semantic levels as follows:

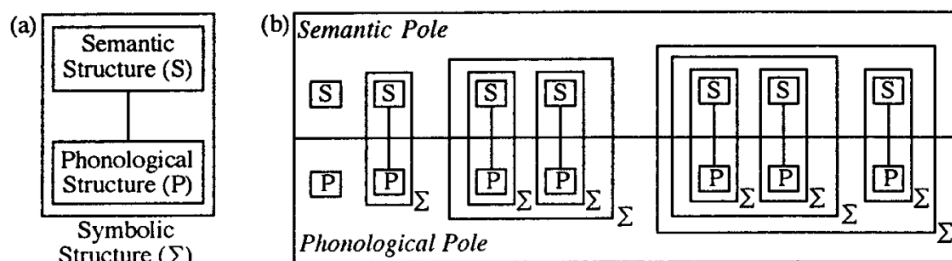

Figure 1. The symbolic structural relation between phonology and semantics (p. 8)

Similar to Langacker's idea, *Construction Grammar's* proposition is that any meaningful configuration of lexical elements in any complexity (be a phrase or a sentence structure) is a distinct entity, namely a *construction*. Despite admitting the role of lexical and syntactic structures for modeling linguistic meaning, the theory allows exceptions to strict compositionality. Both approaches emphasize the importance of grammar while putting forward a model that claims to explain how language ends up being meaningful.

1.2 What History Tells Us

Without going more into the details of linguistics history, which is obviously not the primary purpose of this thesis, it is better to conclude on what history tells us about (i) why we still lack a comprehensive and adequate theory for explaining language-semantics interface and (ii) what may be the fundamental necessary conditions in order to provide such a framework.

From the very beginning of theoretical approaches to language-meaning interface, the scope of the studies was limited to either how atomic units of language, e.g. nouns and verbs, are linked to their meaningful counterparts, e.g. entities and SoA, or how sentences become meaningful based on their compositional properties. It is true that these two forms of isolation (i.e. levels of analysis) helped birth of two distinct and equally important fields of study, namely the categorical and compositional analysis of language respectively. However, the insistent nature of both approaches, on the basis of providing the actual explanations of the referents and structure of expressions despite of their restricted perception of language, ended up with creating a causal drawback on the progress of these fields. There are several underlying reasons of why they failed to provide an adequate answer, but the most apparent of those is that as long as a theory of meaning stays on a single level of analysis (e.g. syntax oriented formalizations vs. conceptual approaches) in isolation – which has been the case for most approaches throughout the history of modern linguistics –, that theory eventually fails to attain the necessary conception of the true complexity of the relation between language and meaning.

Another drawback is the lack of a purely language-independent medium of analysis, to which linguistic structure and cognitive ontology can be mapped to and studied. This is a theoretical problem in the first place, and if anyone could not be able to provide such a medium so far, history cannot be blamed. However, there is a secondary agent in disguise that implicitly

hindered all such attempts: the political power of empiricism on linguistics rising above truth conditions and the associated defense of logic religiously as it being the ultimate form of formalism to all natural phenomena. When the question at hand is meaning, it is already obvious that language uses cognitive mechanisms for representing both mental and contextual states. Exploring these mechanisms will most probably include abstractions of various degrees in the beginning and this is an essential requirement, which should not be attacked by blunt arguments of the kind exemplified above. In addition, with the inclusion of cognitive ontologies, linguistic meaning instantly elevates to a spatial medium of exponentially increasing complexity that is most probably dynamic, fluid and flexible in nature regarding the characteristics of corresponding cognitive information domains. Such a medium may be impossible to fully formalize by linear logical formalisms. Even if we accept that systems of logic are not limited to first-order predicate logic, expanding to highly innovational ends such as answer set programming and fuzzy-logic, we should also leave a considerable margin for parallel efforts such as topological and image-schematic frameworks, which can be made compatible with algebraic conceptions such as set-theory and category-theory upon which many semantics approaches are grounded.

One final remark is about choosing the right linguistic level for semantic analysis, which is often narrowed down to the sentence level. Due to the rapid and equally impactful growth of generativist school in 1950s, semantics studies were not only ripped off from a semantic perspective, but also largely limited to sentence level. This has remained largely true for cognitive linguistic studies as well. However, in order to study language in its broadest scope, discourse level should be accepted as the primary level of the analysis of linguistic meaning. In fact, from a semantic perspective, there is no sharp dividing line between sentence and discourse levels; meaning construction seems to involve similar mechanisms at both levels, as evinced by dynamic semantics frameworks such as Discourse Representation Theory (DRT) (Kamp, 1981; Kamp & Reyle, 1993; Lascarides & Asher, 2003) on the formalist camp, and Mental Space Theory on the cognitive linguistic camp.

In the light of what is discussed so far, the next chapter will attempt to state various conditions for a comprehensive and cognitively adequate theory of linguistic meaning, and clarify a fundamental set of theoretical commitments on which such a theory should be grounded.

CHAPTER 2

VARIOUS FACES OF BUILDING A THEORY

It is necessary for any theory – independent of its target scientific field – to denote its historical motive, but not sufficient. What remains is an analysis of the ground to which the theory is fused. Any theoretical explanation to a well-defined problem is naturally bounded by two major forces: the limiting characteristics of the problem at hand and the related strategies to overcome them in order to provide an answer. By being a highly complex phenomenon, language posits many difficulties to the scientific approaches that aim to penetrate it and while dealing with those difficulties, related approaches inevitably generate their own internal constraints, which eventually define the associated outcomes.

In the scope of this thesis, the ground is divided into three fundamental pillars: *contrasts* that exist in the literature, *commitments* that determine the presuppositions of the theory and *conditions* that are imposed by the nature of the problem, as seen from the specific perspective furnished by theoretical commitments. This chapters aims to lay down relevant theoretical contrasts, clarify the theoretical commitments and finally, propose a set of theoretical conditions on how a cognitively adequate semantic theory should look like.

2.1 Theoretical Contrasts

The development of novel theoretical approaches to scientific problems primarily feeds from the contrasts between already existing perspectives. If the scope is broadened to the question of how human mind and brain should be studied – which becomes relevant under the assumption that meaning is a cognitive phenomenon –, contrasts such as holism vs. reductionism, modularity vs. interactionism, or connectionism vs. computationalism will instantly become relevant. Another relevant level of contrasts is based on the question that what kind of a methodological approach should be embraced in order to achieve a competent degree of resolution to the problem. Based on how much we already know about the problem and its natural characteristics, methodological contrasts such as description vs. explanation or empiricism vs. rationalism define the possible ends of the approach by imposing a certain set of dos and don'ts. As a result of the relative stance that a theory secures in the wide and multi-dimensional spectrum of contrasts, the theory finally takes a step into the level of the problem eventually, which initiates its corresponding destiny. Although theoretical contrasts can be further elaborated, due to practical limitations, only a focused selection of relevant topics will be detailed here: syntax vs. semantics

distinction, linear vs. multi-dimensional representations, and linguistic vs. non-linguistic forms of information.

2.1.1 Syntax vs. Semantics Distinction

Right after the scientific impact created by the generativist school on modern linguistics, a major conflict on the explanation of linguistic meaning was experienced within the field. Generative linguistics paradigm proposed that meaning may be central to language, but there is no need of further abstractions from the surface level, namely the syntactic level, in order to understand the relation between meaning and language. In fact, syntactic structure was assumed to be necessary and sufficient to provide an adequate description to how meaning (logical form) emerges from language. On the other hand, the pursuit for comprehensive semantic analyses continued, primarily within the cognitive linguistics paradigm. Even if these two fundamental approaches experienced a friction, they both provided useful information on various levels of language and still continue to do so with an increasing trend.

The assumption of this thesis is this: Analysis of linguistic meaning can start from either the lowest, i.e. surface, or the highest, i.e. cognitive, level in order to gain a full perspective to the problem. Considering the scientific knowledge about and the methods of penetration into human cognition, for the time being, it seems more plausible to start at the surface level that stands out by being the most apparent level of analysis. A secondary assumption is that language is not a mere collection of atomic elements, but show structural properties, at least a portion of which are visible in the surface level. In line with these two presuppositions, the basic contrast above reveals two important facts about how language and meaning should be studied together: (i) syntax, the study of surface linguistic structure, is currently the primary source of structural information for linguistic analysis and (ii) semantics, the study of meaning, should take syntactic structure into consideration while claiming an explanation on how language is related to the corresponding information structures.

2.1.2 Dimensionality of Representations and the Meta-Language Dilemma

The explanatory power of any theory is directly related with the representational capabilities of the medium that is chosen to describe the problem. The mainstream choice of medium in modern linguistics to describe semantics has been mainly formal-logical representations (e.g., Hobbs, Stickel, Appelt, & Martin, 1993; Kamp, 1981; Lascarides & Asher, 2003; Montague, 1974) based on the assumption that semantic structure is purely a logical structure. At the first glance utilizing logic as the medium of linguistic analysis has its benefits. Logic has already been decided as the ultimate meta-language for all natural phenomena in philosophy at first and later in most of the natural sciences and selecting it as the primary decoding tool of language is no surprise. However, logical analysis necessitates a cautious reevaluation when semantics is the focus of the study. Two main problems regarding logical formalisms will be discussed here: the meta-language dilemma and the problem of multi-dimensionality in higher-level cognitive processes.

2.1.2.1 The Meta-Language Dilemma

The primary requirement of any explanatory paradigm is to provide an adequate ontology of structure building elements to work with. Sometimes the attempt to a solution may inherit the ontology that is inherently existent within the domain of the question, and this may work. But if the problem at hand should be translated outside of its own domain, which is the case for language if the concern is meaning, whether the translation is a formal or informal one, the ontology should be independent.

The *meta-language dilemma* stands for the infertility of the attempt to explain language and semantics by failing to escape the boundaries of natural languages, or more generally, *symbols*. This is a fallacy that is extremely difficult to avoid, due to the fact that language is one of the major tools for descriptive analysis in scientific survey, but when the object of study is language itself, that tool's explanatory power becomes weaker. When a theory aims to explain meaning (which is in and beyond language) via formalisms that one way or another uses a symbolic language again, an unending series of recursions occur. Any linguistic term used within the domain of explanation initiates a search for its own meaning so that it can escape from the domain of language into the independent domain of meaning. However this search can never be successful, if the semantic ontology proposed by the theory is not language-independent, which is an obvious dilemma that constraints the success of meaning theories from the very beginning. Regarding the impact of empiricism and logical positivism, philosophers of the mid-20th century (e.g., Wittgenstein, 1922; Carnap, 1956) found themselves in a conflict between the necessity of avoiding abstract entities in their explanatory models and the necessity of generating them at the same time to fill the gaps that logic and similar strong formalisms could not. When the complexity of the overall problem regarding semantics is considered together with hiatus of a purely language-independent modeling paradigm, it becomes clear why semantic meta-languages lead to an infinite regress.

To be clearer in the description of this argument, let's assume a set-theoretic approach. Let the domain of discourse of language (as the external symbolic system) L be D_L , and the domain of discourse of meaning M be D_M (which may define a meta-language, a formalism, or any other type of a representation). The elements of D_L are morphed into D_M for being conceived in terms of the medium of M . The primary fact is that D_M is an abstraction from, or bound by D_L to a certain degree. Secondly, the morphism is based on the assumption that L has an underlying form, $D_{U(L)}$ that is necessary and sufficient to source D_L to which D_M is expected to converge. Finally, by being successful in the convergence, D_M is expected to explain the phenomenon, L . This basic chain of causal relations is a valid base of evaluation for any theory that tries to explain natural phenomena by providing a domain transformation of any kind, such as the transformation of linguistic expressions into logical propositions. However, the hidden key assumption in this overall enterprise is this: $D_{U(L)}$ should be independent of D_L in order to be conceived out of D_L , such that a hypothetical D_M can explain L by converging to $D_{U(L)}$ without falling into circularity by somehow converging to D_L or to a subset of it instead. To achieve this, any D_M should find a way to describe its own elements by strictly avoiding any kind of explicit or implicit reference to the elements of D_L , or if this is unavoidable in the current state of D_M , it should at least promise an iteration to a future state of D_M , D'_M , such that D'_M eventually satisfies the independence condition. This is the only way, i.e. by being independent of D_L , for a

framework to escape the meta-language dilemma and to provide a working explanation of how language is related to meaning.

The notion of independence is specifically crucial for the problem of linguistic meaning, since any use of symbolic language in the answer will yield a regress to the domain of the problem again. To avoid the meta-language dilemma, one needs to capture and represent meaning by formalisms that go beyond first order logic, or symbolic languages of any kind.

2.1.2.2 Linearity vs. Multi-Dimensionality

Based on what has been assumed so far, when the properties of language-related cognitive domains are concerned, multi-dimensionality of meaning comes into stage. For efficiency in encoding and decoding in line with evolutionary boundaries, language seems to be linear at the surface (phonetic) level. When phonological and morho-syntactic levels are concerned, the system is still largely linear; i.e., describable by the expressive power of first-order logic, possibly with the addition of free variables for anaphoric phenomena. To this one can include syntactic trees, which may look two dimensional; but are actually logical formulas which include scopes and variables for anaphors. However syntactic (and discourse-syntactic) formalisms are useful only for describing relatively shallow levels of language, they fall short of enabling an interpretive relation between symbolic and cognitive domains. In model-theoretic approaches (e.g. dynamic semantics frameworks such as DRT) that start from syntactic structure and progress towards semantic interpretations, logical abstractions are used for moving into the semantic domain; but by being only truth-conditional evaluations, they do not provide much for the cognitive account of meaning.

Language does not exist at a single level. The processing of information accessed via symbolic structures involves various cognitive processes at various levels, which vary in categorical and structural complexity. When all elements included in the formation of semantic value of a linguistic expression concerned, modeling semantics extends well beyond the surface appearance of language. With several postulates of cognitive linguistics, such as generality and dynamicity, it becomes much more fruitful to assume that linguistic meaning as a whole is a multi-layered and multi-dimensional complex system. Thus, any theory that pursues an explanation for linguistic meaning should come up with a working ontology which also covers multi-dimensional, non-symbolic aspects of language processing. Accordingly, the CIS framework presented in this study favors a dynamic, topological network, which is capable of representing multi-dimensional properties of semantics such adequately.

2.1.3 Linguistic vs. Non-linguistic Forms of Information

Verbal capacity of man can obviously expand to allocate all forms of knowledge related to various modes of intelligence. Information exploited by language, in this perspective, cannot come from a single, symbolic form. Thus, a comprehensive theory of meaning should utilize other domains of information, showing how they fit into the framework.

Generative linguistics and similar formal approaches to language and meaning are concerned only with linguistic information at surface level, only up to a syntactic/logical level of abstraction. What these formalisms attempt is to put structural properties of language in focus and propose mechanisms for deriving meaning from these structures. This approach is fruitful in identifying structural information that guides meaning construction, but fails to explain how morpho-syntactic categories themselves convey which kinds of cognitive information. In other words, since language is symbolic and does not have trivially observable links to the real world, a theory which lacks a cognitive ontology will lack an answer to the ‘which’ question, even if it attempts to the ‘how’ question via compositionality, using syntactic dependencies and resulting phrase structures.

There have been three major domains of information that are assumed to contribute to meaning: *symbolic* (information related to the surface level of language), *contextual*⁹ (information related to the communicative medium that is accessible to the communicating agents at the instant of communication), and *cognitive* (information related to mental or cognitive states of the communicating agents).

The contribution of the symbolic level is obvious; otherwise meaning would not be constrained by language and they would not have any principled relation. But the postulation of extra-linguistic domains may create problems; one may need to provide solid verifications to the existence of these domains. Contextual forms of information are easier to back since they are observable and have obvious effects on communicating agents. When it comes to cognitive forms and representations, things become trickier regarding the fact that brain and cognition do not readily reveal their implicit states. But solid and exponentially increasing achievements in related fields of psychology and neuroscience encourage the idea that language is not a modular and self-contained system, but works in relation with many other cognitive mechanisms such as *sensory-motor perception* (Gallese & Lakoff, 2005; Kana, Blum, Ladden, & Ver Hoef, 2012), *visual perception* (Anderson, Chiu, Huetter, & Spivey, 2011; Dehaene et al., 2010; Ferreira & Tanenhaus, 2007; Mishra & Ramos, 2010) and *memory* (Aboitiz, García, Bosman, & Brunetti, 2006; Baddeley, 2003; Burke & Mackay, 1997; Gathercole & Baddeley, 1990; Schank, 1980; Zwaan & Radvansky, 1998). Even if it is early to reveal how contextual and cognitive information contribute to meaning, we have enough clues to justify such an exhaustive effort more than ever before. Regarding this fact, CIS framework assumes that information that contributes to meaning is not language-specific, but includes non-linguistic modes of cognition as well.

⁹ It is a common assumption that contextual information has significant contributions to the disambiguation of language by enhancing the informational content of communication without requiring any symbolic means. In that regard, the initial characteristics of context is defined neither in the symbolic, nor in the cognitive domains: it fills in what is remained from those two within the communicative medium. However, in order to make use of context, communicative agents should assimilate the information content residing in the contextual domain one way or another. This assimilation may likely be a cognitive process of conceptualization upon the target domain, which translates contextual information into cognitive-conceptual information. Thus, contextual domain of information may eventually be included in the cognitive domain, which is a question remained for future analysis.

2.2 Theoretical Commitments and Conditions

Before proposing an elaborated explanation of a theoretical framework, one final and crucial prerequisite is to assert relevant theoretical commitments, to which the theory grounds itself and thus stays devoted to at all times. On the basis of what has been stated so far, fundamental theoretical commitments of this thesis can be summarized as follows:

- i. **Meaning is the ultimate focus of linguistics.** Linguistic phenomena can be fully understood only via a semantic perspective, i.e., in terms of the totality of its interpretative correlates. In other words, the ultimate explanatory resolution into linguistic problems is achieved by means of putting meaning in the center of investigation. Syntactic analyses are indeed useful as starting points for semantic analyses, and as such, they can be considered as shallow levels of semantic processes.
- ii. **Semantics is a problem of general cognition.** Processes relevant to meaning construction are not limited to linguistic knowledge; they involve other cognitive systems including perception, memory, and reasoning.
- iii. **Semantics is a problem of information processing.** The meaning of a linguistic expression is the totality of cognitive information structures involved in its mental processing (in both comprehension and production). The problem of linguistic meaning can be reduced to the study of cognitive processes and cognitive ontologies of information involved in processing language.
- iv. **Semantics is non-linear and dynamic in nature.** Cognitive information and processes that define linguistic meaning come in multiple layers, each of which displaying varying degrees of dimensionality, informational complexity and dynamicity.

In the light of the evaluation of theories on linguistic meaning and the considerations voiced so far, one can cite a necessary set of conditions for a cognitively adequate semantic theory. A cognitively adequate semantic theory should:

- i. take semantics as a natural (cognitive) information processing problem,
- ii. link the symbolic level of language to different levels of cognitive information processing including phonology, morpho-syntax, reference, inference, situation modeling and reasoning,
- iii. account for the contribution of not only symbolic, but also contextual and cognitive types of information,
- iv. focus on the widest scope of the symbolic level, i.e. discourse-syntax, and provide a representational medium to capture structural relations at this level,

- v. provide comprehensive ontologies for each level of cognitive processing,
- vi. characterize the mapping/transformation relations among different layers of information processing,
- vii. and eventually converge to a language-independent, non-symbolic representational space to account for full interpretation.

The framework proposed in the following chapters aims to exemplify such a theory by providing preliminary guidelines. Then, a representational suggestion, namely DSS, will be made for the condition (iv). As already admitted, conditions (v), (vi) and (vii) are difficult to obtain in a single thesis, due to the complex nature of the problems related to cognitive systems. Hence, the framework will remain suggestive for these steps.

CHAPTER 3

A TWO STAGE APPROACH FOR EXPLAINING SEMANTICS

The theoretical framework proposed in this thesis aims to provide an explanatory ground for studying how meaning emerges from language, based on the assumption that semantics is a complex problem of cognitive information processing. It foresees the necessity of a two-stage approach: (i) building a representational framework that is capable of providing a functional ground to analyze the discourse-syntactic level of language, and (ii) building expressive ontologies for every level involved in the cognitive representation.

For the first stage, this thesis proposes the DSS (discourse-syntactic structure) framework, which proposes a network representation that is capable of capturing dynamic state transformations. Its primary function is to anchor a representational space in which any exploratory and descriptive study of linguistic meaning can find itself an adequate medium of investigation.

The second stage, a comprehensive cognitive ontology that covers cognitive correlates of language, is already admitted to be a highly complex task, and is not fully elaborated. Primary levels of cognitive processing are distinguished and guidelines are proposed for how linguistic (discourse-syntactic) structure (DSS) can be mapped into various levels of cognitive information structures. The array of cognitive levels assumed to be primarily relevant for language comprehension and production is called the Cognitive Information Structure (CIS). The highest level of CIS is assumed to cover situation models (as cognitive models of the word), where processes like reasoning, planning and decision making take place. The thesis does not attempt to give a detailed ontology for each level of CIS, but only suggests that all levels can be described by naïve ontologies operating on dynamic networks. Only, the highest level in the hierarchy, namely the situation modeling level, will be argued to consist of analogue, topological representations, which grounds the cognitive system to the external world via sensory experience.

The postponed attempt of elaborating on the exact ontologies of each level would elevate the exploratory and descriptive properties of the framework to an explanatory level by revealing how cognitive information structures are kept and processed, which is expected to reveal eventually a working theory of linguistic semantics.

3.1 A Multi-Layered Dynamic Network Representation for Language-Related Cognitive Information

In *The Sciences of the Artificial*, Herbert Simon (1996) summarizes the idea that all natural and artificial systems are in fact complex structures, which are organized in levels:

“A generalization of the argument made here for the separability of "outer" from "inner" environment shows that we should expect to find this separability, to a greater or lesser degree, in all large and complex systems, whether they are artificial or natural. In its generalized form it is an argument that all nature will be organized in levels.” (p. 7)

Relevantly, the following quote interprets the proposition above by relating the architecture of nature to the nature of corresponding scientific analysis, with an enchanting simplicity:

“We study nature at levels, because it comes to us at levels.” (C. Bozşahin, personal communication, April 16, 2015)

The co-analysis of both ideas concludes with the following requirement: a theory should initially define its levels of analysis in order to achieve a fruitful perspective to the structural properties of the problem in focus.

3.1.1 Levels of Analysis and Levels of Information Processing

Traditional analyses of language assume the following structural levels, in increasing complexity:

- i. *Phonetics*, which is concerned with *the sounds that make up a linguistic signal*,
- ii. *Phonology*, which is concerned with *how sounds are categorized into units and how they are combined*,
- iii. *Morphology*, which is concerned with *minimal meaningful units of language, namely morphemes*,
- iv. *Lexicon*, which is concerned with *the building block of sentences, namely words*,
- v. *Syntax*, which is concerned with *the combinatory properties of sentences*,
- vi. *Discourse*, which is concerned with *how sentences come together to make larger linguistic messages*.

Note that one can take these distinctions as relative to the segment of language taken into account in its surface form, in other words, only to describe the span of the raw linguistic data to be analyzed. A more functional classification, which takes the term *syntax* in a broader sense, will yield the following distinctions:

- i. *Syntax* (of morphemes, lexemes, and sentences), which is the study of *how linguistic units combine with each other*,

- ii. *Semantics* (of morphemes, lexemes, and sentences), which is the study of *explicitly conveyed aspects of linguistic meaning*,
- iii. *Pragmatics* (of morphemes, lexemes, and sentences), which is the study of *implicitly conveyed aspects of linguistic meaning*.

From this perspective, the term *discourse-syntax* will denote a characterization of how formal linguistic elements come together to make up meaningful blocks of speech or text. This is distinguished from discourse cohesion and coherence, which are primarily semantic and pragmatic notions.

The conception of how phonology and semantics are inter-related to each other within a symbolic structure in Cognitive Grammar is insightful about how these two domains are in a direct relation. However, given the fact that each level of language beyond symbolic level (phonetics, orthography or gestures) involves a certain degree of cognitive interaction, the overall semantic coverage of linguistic units goes beyond symbolism. So this thesis adopts a schematically similar basic relation between linguistic level and cognitive levels, where linguistic level provides a starting point for functional and structure-building operations:

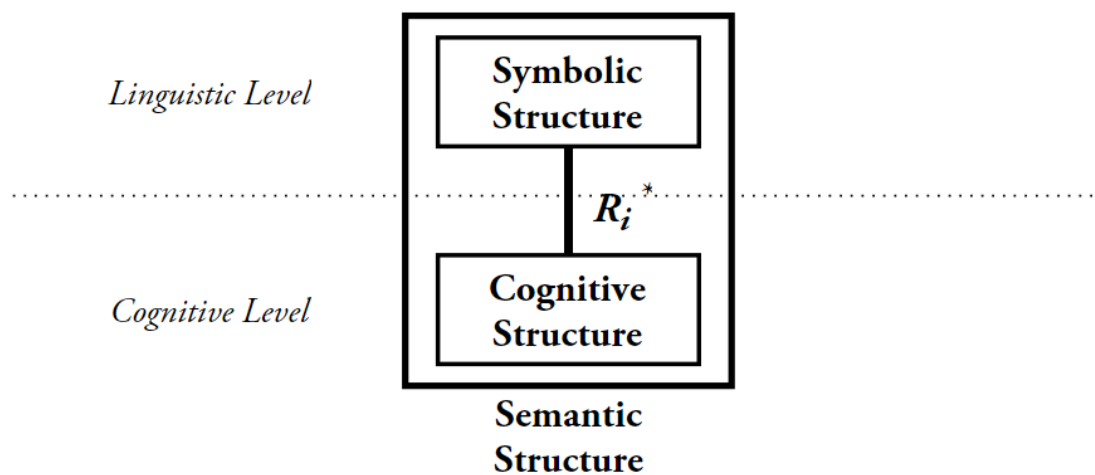

* *Interpretive relation that maps symbolic structure into the cognitive domain.*

Figure 2. The semantic structural relation between linguistic and cognitive levels

Linguistic expressions and related cognitive structures, linked by an interpretive relation, will all together define the semantic structure. From the perspective of language processing (both comprehension and production), this thesis takes the following fundamental levels as semantically relevant, which may reveal further decomposition of levels within their distinct structural organizations:

Table 1. Semantic levels of language processing

Domains	Levels	Stands for	Interacts with and/or Fed by
<i>Linguistic</i>	<i>Symbolic</i>	<i>Phonetic, orthographical or gestural signals</i>	<i>Perception and sensory-motor production (of external symbols)</i>
	<i>Phonological</i>	<i>Phonological structure building relations</i>	<i>Knowledge of phonological rules and intonation</i>
<i>Cognitive</i>	<i>Lexical- Morphemic</i>	<i>Minimal units of syntagmatic combinations</i>	<i>(Morphemic) lexicon</i>
	<i>Discourse-Syntactic</i>	<i>Syntagmatic structure building relations among morphemes, words and sentences</i>	<i>Knowledge of grammatical rules and constructions</i>
	<i>Referential (External and Deictic)</i>	<i>Identification of extra-linguistic entities, relations and properties that may be designated by linguistic units</i>	<i>World knowledge (long-term memory) and contextual knowledge (episodic memory)</i>
	<i>Inferential</i>	<i>Resolution of implicatures, completion and discourse coherence</i>	<i>Pragmatic competence, conceptual integration</i>
	<i>Situation Modeling</i>	<i>Modeling, elaboration and reasoning</i>	<i>World knowledge, knowledge of logic</i>

Hierarchical distribution of semantic levels from lowest to highest, i.e. from most peripheral to most central

As stated earlier, this study does not take the syntactic level as the surface level of language. The most natural conception would be to take the symbolic (phonetic, orthographical, or gestural) level as the surface/external form of language. Cognition is involved as soon as we move away from this surface form. Phonological processing requires a good amount of cognitive processes; e.g., in deciding if two sounds are equivalent in value or not. Similarly, identifying morphemes and lexemes requires a categorization and delimitation, or discovering the syntagmatic structure in a segment of discourse requires the listener's knowledge of grammar. In short, the delimitation of an external signal into morphemes, words, grammatical constructions and intonational contours, as well as detection of co-referential dependency relations require a variety of cognitive abilities. In fact, Chomsky and his followers also take syntactic competence and processing as mental abilities. What they do not admit is that the so-called syntactic processing is a form of semantic processing in the broad conception of the term. Grammatical

category distinctions like verb, noun, adjective, etc. (Langacker, 1987), scope distinctions and co-reference relations are all considered as parts of (shallow) semantics.

This thesis has very little to say about the *phonetic* and *phonological levels* due to its limitations in scope. The *lexical-morphemic level* describes processes related to the recognition of minimal units of syntagmatic combinations, namely, morphemes and lexemes. This layer is directly fed by the morphemic lexicon. The *discourse-syntactic level* receives special attention in this thesis, as the level which structurally informs higher-level cognitive processes related to meaning (see section ‘3.1.4 Representation of the Discourse-Syntactic Structure’). The *referential level* is concerned with how the mind associates linguistic elements with the elements of the world (or, of its mental models). Then comes the *inferential level*, which is traditionally covered under pragmatic studies. It covers phenomena which are implicitly conveyed by utterances, including conventional and conversational implicatures and explicatures (e.g., Grice, 1975; Sperber & Wilson, 1986), presuppositions (e.g., Kamp & Reyle, 1993; Strawson, 1952), illocutionary intentions (e.g. Searle, 1976), implicit discourse relations for discourse coherence (REF) as well as completion of mental space information in the process of conceptual integration (Fauconnier & Turner, 1998). Lastly, the *situation modeling level* encompasses the formation of meaningful conceptual constructs for mentally representing the world. This is the domain which is relevant to mental models (Johnson-Laird, 1983), situation models (Barwise & Perry, 1983; Zwaan & Radvansky, 1998), mental spaces (Fauconnier 1985), idealized cognitive models (Brugman & Lakoff, 1988; Lakoff, 1987b), frames (Barsalou, 2008), or geometric conceptual spaces (Gärdenfors, 2000). Whether this level is based on symbolic/propositional representations in discrete form or topological/geometric representations in analogue form is a current debate. This thesis favors imagistic, topological representations, primarily to avoid the meta-language dilemma (stated in section ‘2.1.2.1 The Meta-Language Dilemma’) and their ability to capture multi-dimensional complexity (see sections ‘3.1.2 How to Represent Levels?’ and ‘3.1.3 More on Dynamicity’). Also, such representations have good prospects for being grounded on embodied experience (Barsalou, 2008; Evans, 2009). Whatever the form of representation at this level may be, some high level cognitive abilities are assumed to be effective at this level. These include logical inferences (deduction and induction), generalization, planning, decision making, as well as recovery of perlocutionary intentions behind linguistic utterances.

A key aspect of the framework presented here concerns interactions among different levels of semantic processing. Before elaborating on this, one should note that language involves an act of communication which works in two ways: when an internal cognitive information structure is translated into a linguistic expression, *production*, and when an external linguistic expression is translated into a cognitive information structure, *comprehension*. The assumption here is that although some different processes are involved, basic cognitive mechanisms are the same in both processes: they are simply conjugates of each other in reverse order. The CIS framework prefers to initiate the modeling of linguistic meaning via the decomposition of surface linguistic from into structural elements, and thus embraces the level of *comprehension* as its level of process analysis. From this perspective, meaning reveals itself initially from the unfolding of surface linguistic structure and later through the generation of links that move deeper in the cognitive conceptual levels.

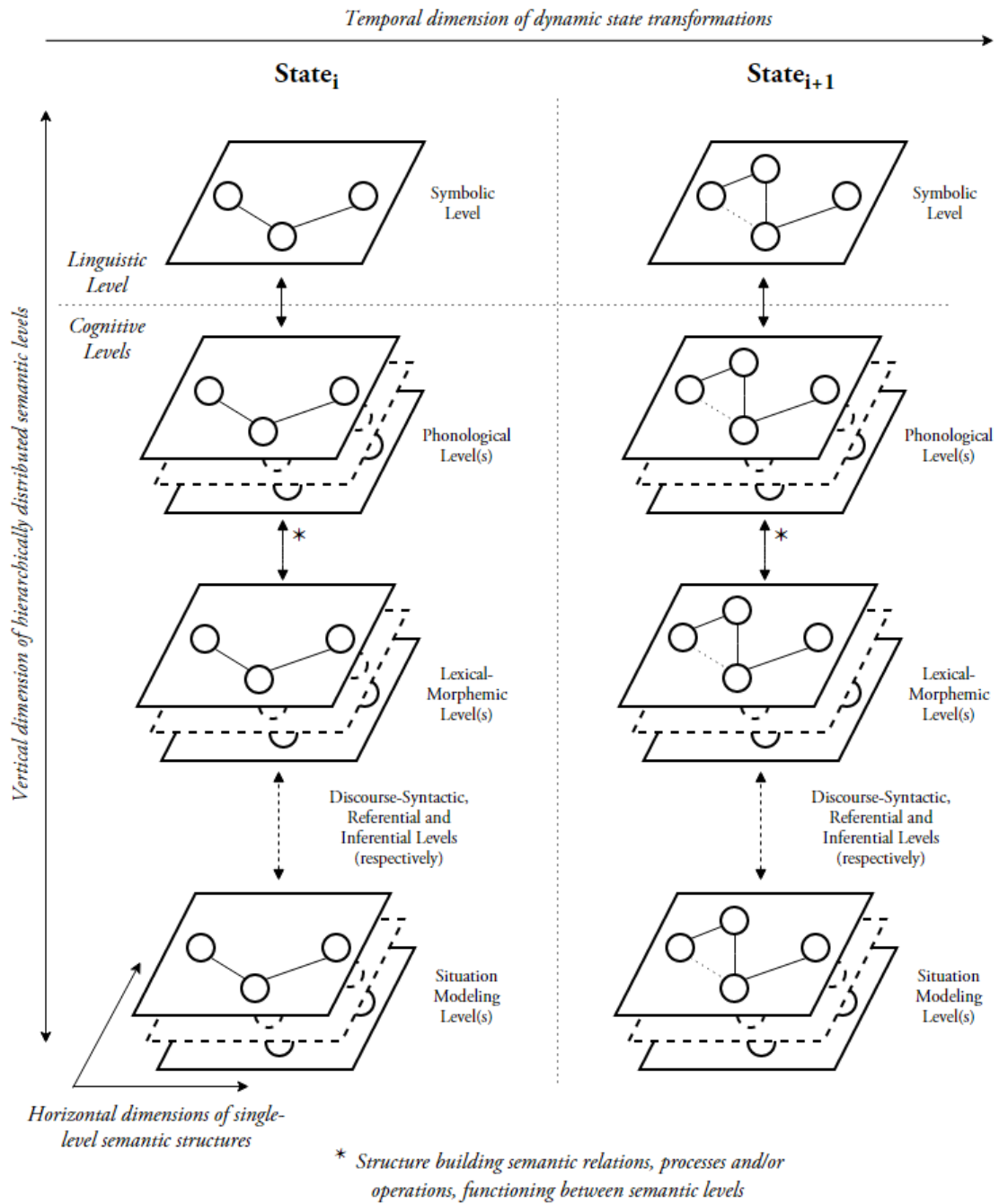

Note: Basic networks illustrated on levels does not necessarily entail the preservation of structure along semantic levels (even if they are shown like that in this figure), but temporal differentiation in structure is expected along semantic processes.

Figure 3. Spatial representation of the semantic structure, including primarily the levels listed in 'Table 1'.

The CIS framework critically claims *parallel processes at each level*, as a discourse unfolds. So in principle, operations at each level can affect and can be affected by operations at other levels. A few examples will help clarify the point. Assume that a hearer is processing a spoken discourse and encounters the English present perfect (*have ... ed*) strategy. This strategy comes in a series of *phonetic forms*, to be perceived as an array of general *phonological forms*. Although being bipartite, it defines a *morphemic unit* that should be recognized as such. The strategy is of

course subject to *syntactic/grammatical rules*, and involves *deictic reference* to time (past relative to reference time). It takes an *inference* to conjecture relevant present results of the mentioned event, and the strategy contributes to *discourse coherence*, e.g. by signaling a causal relation between past and present. Lastly, it plays a role in building *situation models*, since it says something about both a past occurrence and the present situation. This in turn contributes to high level cognitive processes like reasoning and decision making on the basis of the current knowledge state. One can easily repeat this exercise with a variety of morphemes, words, constructions or larger linguistic segments. These interactions work in both top-down and bottom-up directions, which practically means that semantic processing (language understanding and production) involve simultaneous recruitment of complex cognitive structures at multiple layers.

3.1.2 How to Represent Levels?

As stated in the very beginning of this thesis, uncovering the true extent of cognitive ontology is an extremely difficult task and thus cannot be reasonably attempted within a single thesis. However these levels are central for understanding linguistic meaning due to both evidential reasons and theoretical commitments and it is worth to consider possibilities for representation.

Symbolic information on *symbolic level* is basically linear, consisting of an array of distinctive sounds, written characters or gestures. As to cognitive levels, it should be admitted that each may require a different representational medium. *Phonological level* seems to involve linearity, but it actually includes at least a superimposition of a phonological string and an intonational contour. *Lexical-morphological* processes operate on both of these dimensions, to identify categorical elements in the string. The *discourse-syntactic level* can also be seen to involve some degree of linearity, although it also features dependency relations and co-reference links that makes it necessary to include scope distinctions as well as crossing dependencies. As will be elaborated later, the highest level; the *level of situation modeling* may be different from all others in incorporating image schematic, topological representations.

Table 2. Representation of basic cognitive classes on networks

Basic Cognitive Classes	Basic Representational Classes
<i>Element</i>	<i>Node</i>
<i>Relation</i>	<i>Edge</i>
<i>Structure</i>	<i>Construct</i>

Still, due to the necessity of parallel interactions among levels, as mentioned above, levels should be able to communicate via associative links. In order to satisfy this, the ontology of cognitive levels should be compatible with each other. This can be achieved only if all levels are describable by a similar medium. This medium is argued here to be a *network structure*. The correlations among symbolic and cognitive levels can be secured by associations among *basic cognitive classes* (superordinate types) that operate at each level: *Elements* that source the ontology, *relations* that form links between classes of the ontology, and finally the *structures* that are generated by them. These will be represented in networks by *nodes*, *edges* and *constructs*, respectively.

A node is represented by a circle, which is specified by a symbolic tag that stands for its ontological form. Nodes represent elementary units of cognitive ontologies, which correspond to static structures of semantic information in isolation. A node can exist in isolation within a network, independent of any relational link to any other nodes by being the primary building block of the representation.

Table 3. Representational form of a node in CIS

Basic Cognitive Class	Basic Representational Class	Representational Form
<i>Element</i>	<i>Node (N)</i>	⊙

Edges represent the relation building units of cognitive ontologies, which correspond to information processing operators that configure constructs. In that regard, an edge cannot exist in isolation within a network, by being functionally dependent on variables to operate on. In relevance to the classical uses of network representations, it may seem odd to connect edges to other ones, but it is important to note that it is not the representation that explains the phenomenon, but the phenomenon is explored with the help of network representations. This is similar to that of an algebraic function that takes another function as its variable, which changes the output of the given function by a degree of the input function. Logically-speaking, allowing such nodes makes the system a higher-order one.

The final topological class is the construct, which is a combination of nodes and edges of a specific complexity. Constructs can be represented by a single node within the horizontal space that is at least one-level higher than the structure that it represents. In that regard, elements of higher ontological dimensions can be complex structures which lie in lower dimensions. This mechanism provides a possibility for information to structurally build up vertically along levels.

Table 4. Representational form of edges in CIS

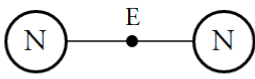
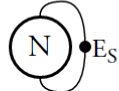
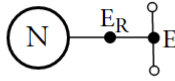
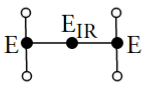
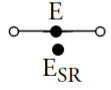
Basic Cognitive Class	Basic Representational Class	Representational Form
	Edge (E)	
	Self Edge (E_S)	
Relation	Relational Edge (E_R)	
	Inter-relational Edge (E_{IR})	
	Self-relational Edge (E_{SR})	

Such a network representation has the capacity of capturing structural properties of set-theoretic, category-theoretic and type-theoretic classifications that aim to capture ontological distributions of conceptual entities. Being able to link relations to each other, it actually exhibits the representational power of higher-order logics. Such a network representation is a powerful medium which imposes no special constraints on what can be represented. Such constraints, which are apparently there, can be attributed to the effects of language user's knowledge of linguistic rules (i.e., for the discourse-syntactic level; knowledge of grammatical rules and knowledge of discourse-connectedness, for the level of phonology; knowledge of phonological rules, etc.).

Table 5. Representational form of a construct in CIS

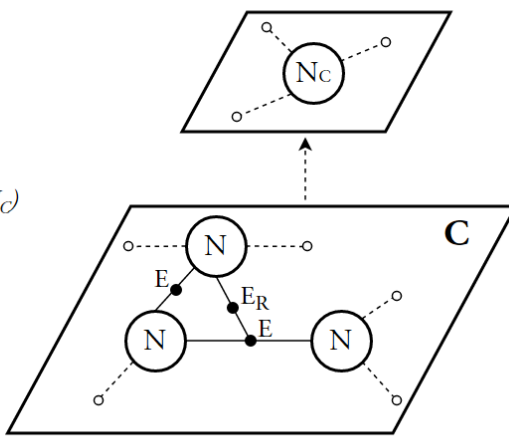
Basic Cognitive Class	Basic Representational Class	Representational Form
Structure	Construct (C, N_C)	

Network representation can be assumed to pervade all layers of cognitive information structure, but one may admit that the ultimate layer of semantic interpretation, namely the situation modeling level, may well be geometrically represented. Situation modeling has been represented by symbolic-logical formalisms with a certain degree of success, (e.g., Johnson-Laird, 1983; Barwise & Perry, 1983). However, this is also the most natural level where image schemata are embedded and idealized cognitive models reside. As Brugman and Lakoff (1988) argue in detail for the English preposition ‘over’, the topological arrangement of situations seems to give rise to inferences which are difficult, if not impossible to obtain by discrete symbolic representation. After all, this level is directly fed by perceptual input of all types (see e.g., Barsalou, 2008), hence can be fundamentally different from other levels by being analog rather than discrete. If analog representations define the right perspective for modeling high-level cognition, then mappings from previous levels to this level may well include transformations from discrete (algebraic) to analog (geometric) constructs. The exact nature and operation of such transformations or mappings are well beyond the scope of this thesis.

As it is previously told, CIS framework approaches linguistic semantics from the perspective of language comprehension and the primary level of comprehension is decoding linguistic terms into their cognitive counterparts. Revealing the true character of all cognitive ontologies is already the ‘NP-hard’ problem of all human-related-sciences, thus the apparent way of attacking to the problem is starting with experimenting how language may be projected on to the network representation via the discourse-syntactic level. This will be attempted in the next section, by the DSS framework.

3.1.3 More on Dynamicity

“Mind is nothing, but matter in motion.” (Haugeland, 1997, p. 2) Analogically, meaning is nothing, but information in motion. This may seem a very simplistic explanation, but the phrase catches the fundamental characteristics of meaning as dynamically evolving cognitive information. Accordingly, CIS framework proposes a specially adjusted representational ground for the sake of demonstrating the dynamicity of the relation between language and meaning by inheriting and building upon the basic components of network representation.

A distinctive property of the CIS is its inclusion of the temporal dimension, such that each specific structural configuration of the three dimensional network space is encoded within a corresponding temporal state. With the progress of comprehension via incremental addition of incoming linguistic elements from the discourse, or from other (cognitive or contextual) input systems, novel elements, nodes and edges are created. These may cause varying degrees of configurational changes within the network structures at every level. This dynamic transformation continues until the whole discourse is consumed by comprehension processes, which yields a set of temporally connected states via dynamic state transformations.

Conceptual relations at deeper levels of cognitive ontology can be initiated by dynamic processes based on input set by surface structure, by other external/sensory stimuli, or by other extra-linguistic cognitive processes. An elaboration in that direction is the *spreading activation* (Anderson, 1983; Collins & Loftus, 1975; Klinger, Burton, & Pitts, 2000) theory, which

explains the diffusion activation among semantically-related elements, in line with the processing of surface language.

Another feature of dynamic networks proposed here is its ability to change structural configurations by *activations* and *deactivations* of nodes and edges, i.e. elements and relations. With the introduction of a node or an edge into the network, the corresponding element or relation is activated at that very instant. However, this activation is not static and preserved throughout the semantic comprehension process, but dynamically adjusted in line with *temporal focus* and *intentional focus*. Temporal focus is a temporal boundary enforced upon active nodes and relations with respect to off-line cognitive processes such as the temporal extent of working memory or the dynamics of spreading activations, which allows a node or a relation to be active only for a certain period of time after which the activation diminishes.

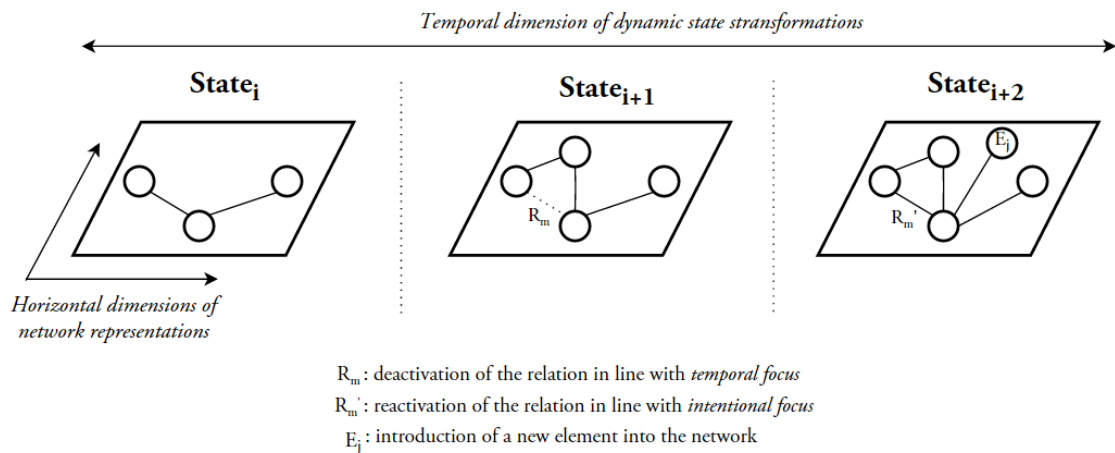

Figure 1. Possible instantiations of temporal and intentional focus

Intentional focus, on the other hand, is an assumed on-line process that is consciously enforced by the subject based on various intentions, e.g. in line with personal choice of focus on certain types of information structures, which enables the activation of a certain combination of nodes and relations to extend beyond their default temporal focus. A final assumption is that by the introduction of certain types of elements (e.g. anaphoric or presuppositional strategies), inactive nodes can be reactivated again and contribute to the latter states of cognitive structures.

A dynamic network, based on multi-dimensional networks of nodes (elements) and edges (relations) stands out as a promising medium, by enabling a concurrent representation of any information structure and ontology in spatial and temporal dimensions. The temporal dimension provides a basis on which the dynamicity of cognitive semantic phenomenon can be demonstrated in line with various temporally defined semantic functions. In the CIS framework, horizontal dimensions constitutes the planar mediums that host horizontally extended structures, i.e. network representations for cognitive ontologies, and the vertical dimension constitutes the depth through which the layers are inter-related via mappings, hierarchical and taxonomic relations. In that regard, these three dimensions build up a holistic structure that can extend in all directions.

3.1.4 Representation of the Discourse-Syntactic Structure

In this thesis, representations and analyses at the phonological and lexical-morphological levels are omitted for now due to both practical and theoretical reasons, even if they are symbolically (and sometimes iconically) structured and related to meaning as well. Similarly, the CIS framework leaves higher-level cognitive structures to the scope of future studies and possible collaborations of other researcher's due to the complexity and the difficulty of the problem. What is plausible for a semantic analysis on language, then, is to start by discovering the structure at the level of *discourse-syntax*.

In this section, the representation of the discourse-syntactic level will be elaborated by proposing some elements, relations and structures on a network topology. The effort here does not claim any empirical achievement, but considering the necessity of building a stable interface between the linguistic and cognitive levels, it is proposed primarily for exploratory purposes.

As stated earlier, dynamic networks are assumed to be constituted by three fundamental classes: *the node*, *the edge* and *the construct*. At the discourse syntactic level, these classes can be used to define a Discourse-Syntactic Structure (DSS) framework. Again, as already admitted, at each level of cognitive information, there seems to be constraints in representation which are narrower than the expressive power of a network representation. When it comes to discourse-syntax, dynamic semantics accounts like DRT provide valuable insights as to the accessibility relations for anaphora and presupposition resolution, on the basis of scope hierarchies. SDRT claims the *right frontier constraint* on attaching new elements to existing segments of discourse. Discussions are still ongoing as to whether the structure of discourse can be represented by simple predicate-argument structures formulated in first-order logic, or by simple tree structures with scope-sensitive dependencies (see Demirşahin, 2015). These findings do not pose any serious challenge to the network representation, because these all can be incorporated into the framework by supplementing linguistic knowledge fed into the system.

Traditional linguistics and syntax-oriented approaches have mostly settled with eight grammatical parts of speech so far, which are *verb*, *noun*, *pronoun*, *adjective*, *adverb*, *preposition*, *conjunction*, and *interjection*. This simplified approach to the classification of linguistic elements worked most of the times within related scopes of studies, because their primary concern has been revealing the trends of their configurations and arrangements in the surface, independent of any other phenomenal level that may be related to the language. When it comes to a semantic approach to grammar, the primary requirement is to make abstractions due to ontological necessities and when those abstractions are ready to go, it becomes much more necessary to provide an adequate ground on to which the abstraction will be projected. Semantics is all about information and its ontological reality, thus if a semantic abstraction is required for projecting linguistic structure to somewhere else – in this case, the CIS framework – , even diminutive differences of semantic functions between the elements of the same grammatical class start to generate problems. An overview of cross-linguistic studies on how well-known and widely-used morpho-syntactic categories can be further detailed by analyzing their semantic contents will reveal that just a subset of those classes, e.g. verbs, pronouns and TAM markers, is enough to conclude that not only to provide a cognitive semantic ontology is difficult, but also providing a comprehensive functional categorization for surface linguistic

forms is highly problematic as well. For the case of semantic representational approaches, the problem elevates such that semantic variations within the instances of the same class usually implies variations in representational strategies used to represent them, which increases the types of representational elements proportionally. In that regard, within the scope of the DSS framework, only a relatively less-problematic subset of linguistic classes and/or their instantiations are represented, which is expected to yield a sufficient basis for an adequate investigative medium.

Table 6. Elementary units of DSS ontology together with how they are represented in a dynamic network

Basic Cognitive Class	Basic DSS Class	Syntactic Class/Construction	Representational Form
<i>Element</i>	<i>Conceptual (CP)</i>	<i>Noun</i> <i>Adjective</i> <i>Adverb</i>	⊙ _{CP}
	<i>Referential (RF)</i>	<i>Pronoun</i>	⊙ _{CP}
	<i>Conceptual Set (CPS)</i>	<i>Noun + 'and/or' + Noun</i> <i>Adj. + 'and/or' + Adj.</i> <i>Adv. + 'and/or' + Adv.</i> <i>Pro. + 'and/or' + Pro.</i>	⊙ _{CPS_{CCO(i,j)}} $i, j \in \{CP, RF\}$

DSS framework, similar to its approach to cognitive and representational domains, divides grammatical categories into three by virtue of their assumed semantic mappings: elementary, relation-building and structural. Elementary classes of language are defined as the ones those function as static units primarily providing chunks of information content, namely *nouns*, *adjectives* and *adverbs*. *Pronouns* are also included in this set, because they function by referring either to nouns or to phrase structures, both of which are static and enclosed semantic structures. One final type included in here is combinations of nouns, adjectives, adverbs or pronouns by the use of conjunctives *and/or*, which yields a multiple element set structure of elementary types.

Within the framework, most of linguistic types are considered as relation-building operators, primary of which is *verb*. Verbs generally denote actions, occurrences and states by framing the dependent nouns such that the configurational properties of a verb determine the change of semantic information sourced by the noun in temporal dimension. An introspective analysis reveals that verbs are not conceptualized by themselves in isolation, but through patterns of transformation conceived via nouns. Even if they have their own semantic and conceptual structures, their linguistic function seems to be more like a morphism by virtue of how they operate on their target static information structures and eventually transforms them.

Table 7. Verbs and prepositions in DSS ontology together with how they are represented in a dynamic network

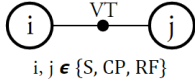
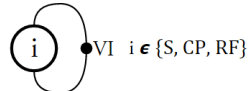
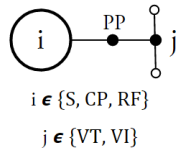
Basic Cognitive Class	Basic DSS Class	Syntactic Class/Construction	Representational Form
	Verbal Transitive (VT)	Verb	
Relation	Verbal Intransitive (VI)		
	Prepositional (PP)	Preposition	

Prepositions are similar to verbs by their functional resemblance to structure-building processes, but in addition they seem to function as intermediate operators by further configuring the transformational effect of verbs on their target nouns. Another idea may be that prepositions primarily configures their dependent nouns, but if this is the case, then the resulting static information structure will be expected to be compatible with the incoming configurations of the verb. In many cases, such an approach yields counterintuitive results.

- (i) *The man stands on the table.*
- (i') *The man stands [on_the_table].*
- (i'') *The man [stands_on] the table.*

From a semantic ontological perspective, the strategy assumed in (i') is expected to yield a noun-like information structure, by focusing the physical information provided by the *table* on to its upper surface and enforces a relation between that limited information and the verb, *stand*. However, *stand* is an intransitive verb, which cannot configure a noun that follows it in word order. Thus, strategy (i') becomes counterintuitive by enforcing an intransitive verb to act like a transitive one. That is why the second approach (ii') is considered by this thesis as a more plausible one, such that the configurational changes posited by the preposition *on* upon the verb *stand* may be resulting in a new configuration in which the new relation building structure, *[stand_on]*, can act like a transitive and thus relate to the subsequent noun. This analysis is obviously a very limited and simplistic one, but while deciding the ontological properties of linguistic types, practical choices were made since the primary purpose of this thesis is to provide a representational framework instead of revealing the true ontological nature of various linguistic elements. In that regard, prepositions are decided as relation-building entities.

Another relation building type is *conjunctions*, by being apparent relation builders even in the linguistic level. A brief examination on them reveals that at least three subordinate classes can be

derived based on how they relate linguistic units to each other, e.g. by causal and temporal relations.

Table 8. Conjunctions in DSS ontology together with how they are represented in a dynamic network

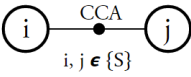
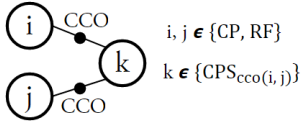
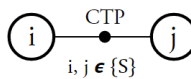
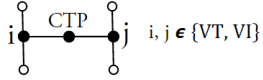
Basic Cognitive Class	Basic DSS Class	Syntactic Class/Construction	Representational Form
Relation	Causal Conjunctive (CCA)	'but', 'however', ...	
	Combinatory Conjunctive (CCO)	'and', 'or'	
	Temporal Conjunctive (CTP)	'and'	 

One interesting relation proposed by this thesis is *modifiers* relations, such that unlike other relation building constructs, modifiers are implicit and does not reveal themselves in the surface linguistic level.

Table 9. Implicit modificatory relations and TA in DSS ontology together with how they are represented in a dynamic network

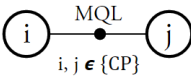
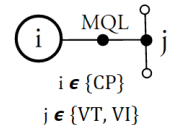
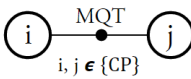
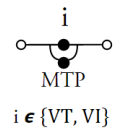
Basic Cognitive Class	Basic DSS Class	Syntactic Class/Construction	Representational Form
Relation	Modificatory Qualifier (MQL)	Adjective Adverb	 
	Modificatory Quantifier (MQT)	'many', '2', 80%, ...	
	Modificatory Temporalizer (MTP)	Tense Aspect	

This is one of the few abstractions made by the naïve ontology, based on the ontological choice of defining adjectives (*quantifiers* are included in adjectives) and adverbs as elementary semantic structures in the beginning. However they apparently modify the information content of their target types, namely nouns and verbs, and should be related to their targets by some kind of relation-building constructs. Modificatory relations are such constructs that are assumed to be inheriting relevant information from modifying types and operate them on the semantic structure of target types based on certain configurational properties. *Tense* and *aspect*, on the other hand, are also included in the category of modificatory relations, but they are explicit relations by themselves, acting directly upon the verb that they relate to via a generic temporal ontology. Even if there are various promising temporal ontologies for TAM in the literature, they are not inherited in this thesis in order to avoid further abstractions and the corresponding temporal relations within the naïve ontology are directly tagged by associated morphemes (e.g. *-ing*, *-ed*) and constructs (e.g. *have been*, *will*, *going to*).

Possessives are also included within the framework as direct relation builders of the possession relation between the noun that is possessed and the noun, which possesses it. Such self-referential explanations do not make much of a sense, but for the sake of practicality (as it is justified by specific reasons several times before) they are left without further analysis.

Table 10. Primitive grammatical constructions in DSS ontology together with how they are represented in a dynamic network

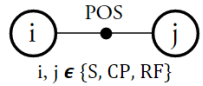
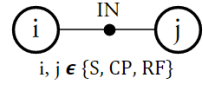
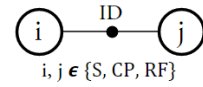
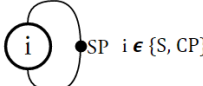
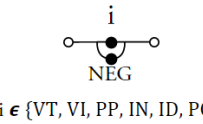
Basic Cognitive Class	Basic DSS Class	Syntactic Class/Construction	Representational Form
	<i>Possessive (POS)</i>	<i>Possessive</i>	
	<i>Inheritance (IN)</i>	<i>'is (a)'</i> , <i>'are (a)'</i>	
<i>Relation</i>	<i>Identity (ID)</i>	<i>'is (the)'</i> , <i>'are (the)'</i>	
	<i>Specificity (SP)</i>	<i>'a'</i> , <i>'the'</i>	
	<i>Negating (NEG)</i>	<i>'not'</i>	

Before concluding, four primitive relations are also defined, which are considered to be equally important for their frequent occurrence in linguistic expressions, not by being types of generic grammatical classes, but by being generic grammatical constructions. The first one is the

inheritance relation, which is observed linguistically in the form of ‘*is/are (a)*’ that holds between all elementary types, enabling the preceding element to access and inherit the semantic properties of the subsequent one. A similar relation builder to inheritance is the *identity* relation, which is observed linguistically in the form of ‘*is/are (the)*’ that holds between all elementary types as well and indicates that the inter-related elements are the same, i.e. identical to each other. Beneath its introduction into the discourse in the form of an explicit linguistic form, the relation also holds by default implicitly between a pronoun and its referent. *Specificity* is another construct, which is observed linguistically in the form of ‘*a/the*’, namely the *articles*. What they specifically contribute to the discourse is the information of whether their target element is specified within the discourse or not, i.e. whether it is introduced before or introduced for the first time. One final relation is the *sine qua non* of all semantic representations (especially the logical ones), which is the *negating* relation that is linguistically observed in the form of ‘*not*’. Whatever the configurational or informational consequences of it (which requires a very comprehensive analysis of cross-linguistic use cases), it can relate to most of major relations, such as verbal, prepositional, inheritance and identity relations by basically negating their configurational effect on their target types.

The final ontological type is the *structure* that basically acts like elementary types in terms of being a static information structure, which shares the name of its corresponding basic ontological class.

Table 11. Representing a discourse in a dynamic network, based on the DSS ontology

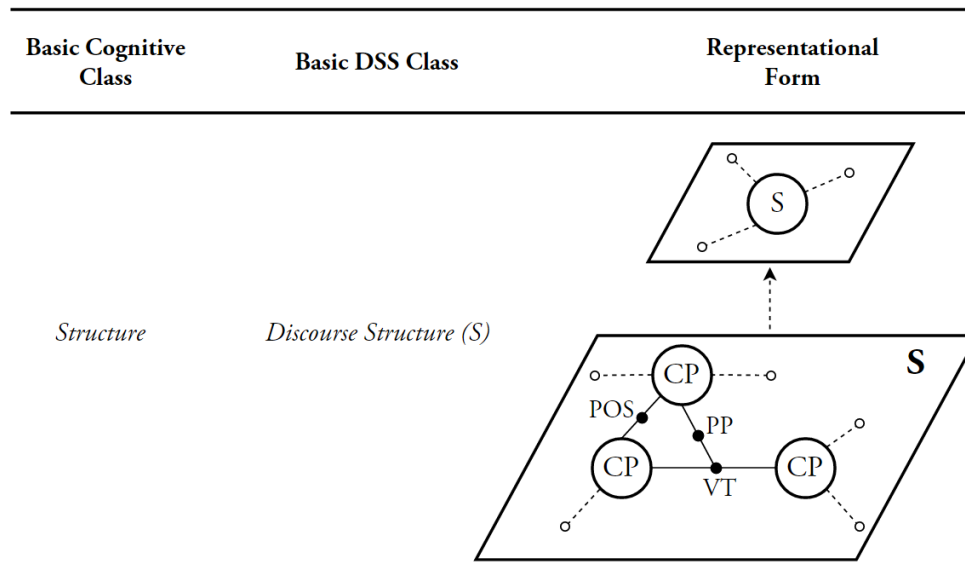

Structures are basically discourses that satisfy at least the grammatical structure of a single clause, but apart from that requirement, they can be of any complexity. They are constructed as abstract entities mainly by the influence of references introduced by pronouns and related to within a network after they are abstracted into a higher ontological level, i.e. at least one level higher from the level at which they were structured.

The elaboration on translating linguistic terms into an extra-linguistic ontology is ceased here by a hopeful assumption that it is detailed more than enough to understand what the DSS framework is, how it conceives discourse-syntactic structure and how it makes a use of it. Now, one final attempt in the scope of this thesis will be an applied analysis of dynamic networks via sample discourses of various complexities, which will help the reader to better understand how DSS works out in the world.

3.2 An English Based Exemplification of the DSS

This section is simply divided into two: (i) the analysis of example sentences for each DSS type introduced in the previous section and (ii) the analysis of a sample discourse that is composed of multiple sentences and includes all DSS types at least once, all of which will constitute a comprehensive and adequate attempt to see how DSS and dynamic networks work together in full resolution, within the limits of its naïve ontology. For the first part, dynamicity principle is disregarded by setting the minimal unit of comprehension to sentence level, and in each example, only a single sentence is represented. In that regard, representational variations required by configurational changes (e.g. word order) made on the sample sentences is not demonstrated; but keep in mind that DSS regards the comprehension of all examples as dynamic processes in which the minimal unit of representation is morphemes (e.g. MTP). Thus, the aforementioned configurational changes can actually be captured as a function of state transformations (see ‘Equation 1’) along the progressive interpretation of the linguistic expression.

3.2.1 Verbal Transitive (VT)

Example 1

{Raw} John hit Mary.
 {Ann_{DSS}} CP_{John} VT_{hit} CP_{Mary}
 {DSS}

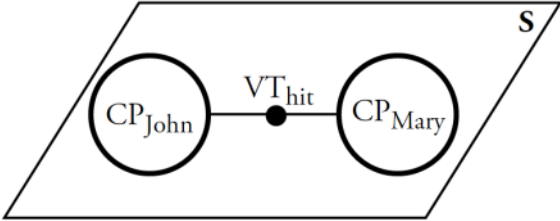

Figure 4. DSS of ‘Example 1’, demonstrating the representation of VT

3.2.2 Verbal Intransitive (VI)

Example 2

{Raw} John sleeps.
 {Ann_{DSS}} CP_{John} VI_{sleeps}

{DSS}

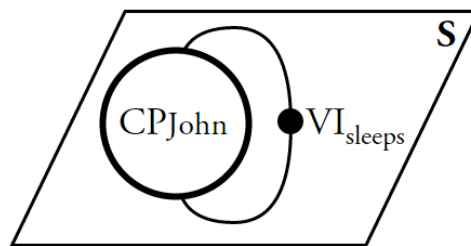

Figure 5. DSS of 'Example 2', demonstrating the representation of VI

3.2.3 Prepositional (PP)

Example 3

{Raw} John hit Mary with a hammer.
 {Ann_{DSS}} CP_{John} VT_{hit} CP_{Mary} PP_{with} SP_a CP_{hammer}

{DSS}

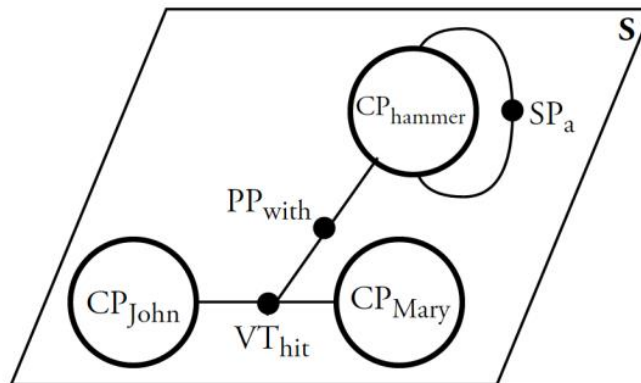

Figure 6. DSS of 'Example 3', demonstrating the representation of PP

Example 4

{Raw} John stands on a box.
 {AnnDSS} CP_{John} VI_{stands} PP_{on} SP_a CP_{box}
 {DSS}

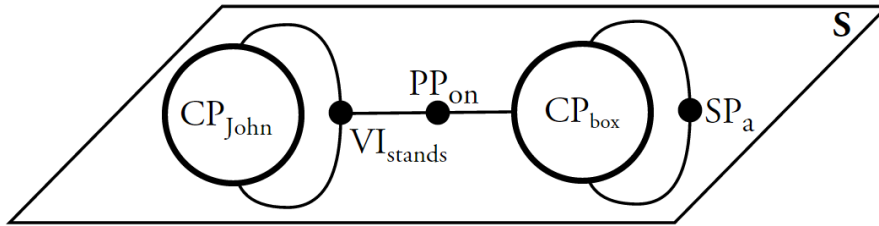

Figure 7. DSS of 'Example 4', demonstrating the representation of PP

3.2.4 Causal Conjunctive (CCA)

Example 5

{Raw} John loved Mary, but he left her.
 {AnnDSS} CP_{John} VT_{loved} CP_{Mary} CCA_{but} RF_{he} VT_{left} RF_{her}
 {DSS}

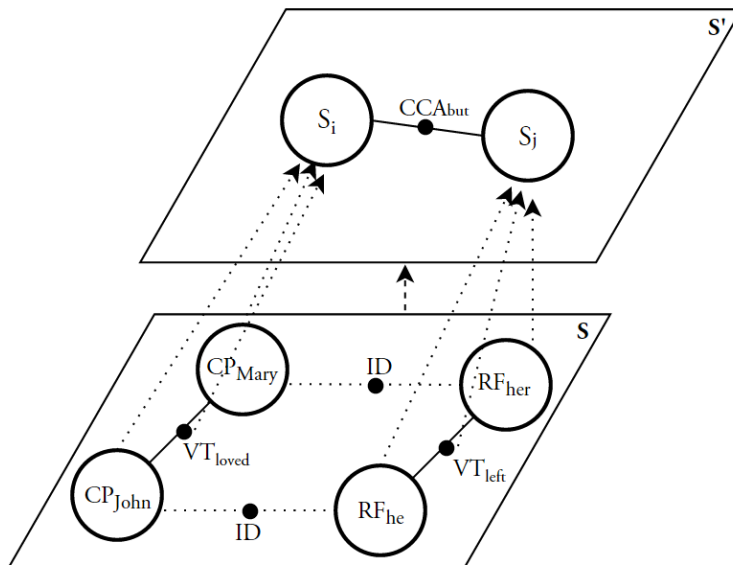

Figure 8. DSS of 'Example 5', demonstrating the representation of CCA

3.2.5 Combinatory Conjunctive (CCO)

Example 6

{Raw} John and Mary listened to the song.
 {Ann_{DSS}} CP_{John} CCO_{and} CP_{Mary} VI_{listened} PP_{to} SP_{the} CP_{song}
 {DSS}

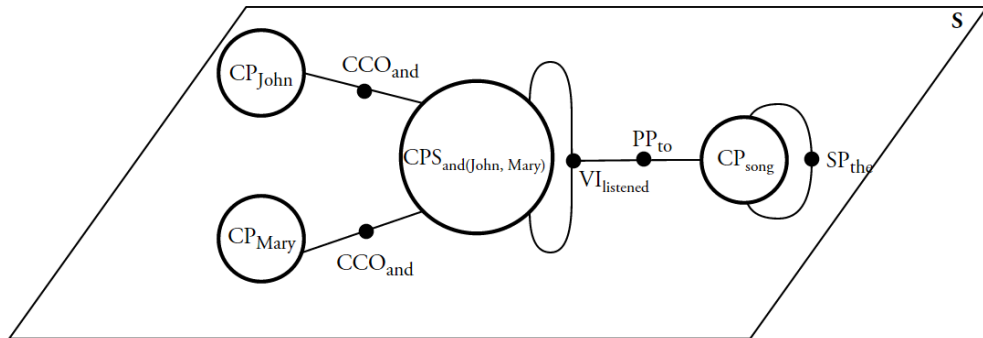

Figure 9. DSS of 'Example 6', demonstrating the representation of CCO

3.2.6 Temporal Conjunctive (CTP)

Example 7

{Raw} John shot the man and ran.
 {Ann_{DSS}} CP_{John} VT_{shot} SP_{the} CP_{man} CTP_{and} VI_{ran}
 {DSS}

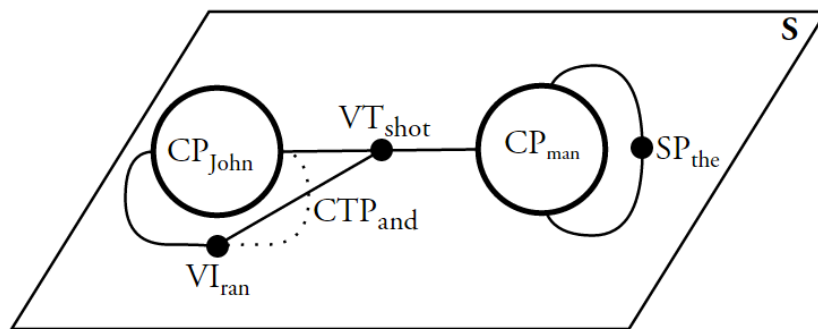

Figure 10. DSS of 'Example 7', demonstrating the representation of CTP

3.2.7 Modificatory Qualifier (MQL)

Example 8

{Raw} Green car was on the road.
 {AnnDSS} CP_{green} [MQL] CP_{car} VI_{was} PP_{on} SP_{the} CP_{road}
 {DSS}

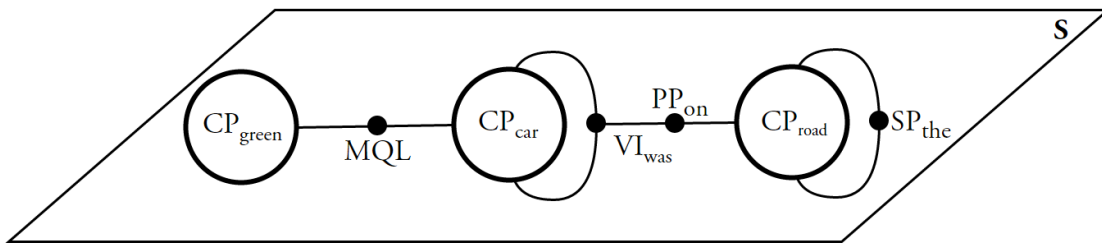

Figure 11. DSS of 'Example 8', demonstrating the representation of MQL

Example 9

{Raw} He drove fast.
 {AnnDSS} RF_{he} VI_{drove} [MQL] CP_{fast}
 {DSS}

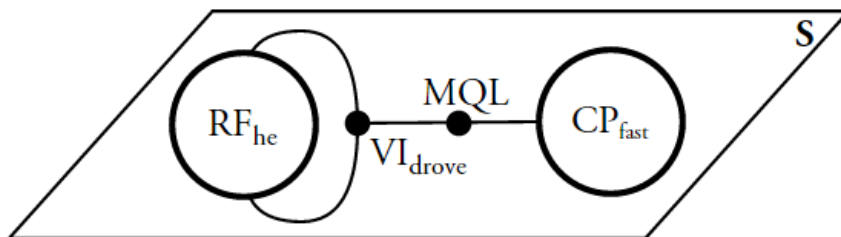

Figure 12. DSS of 'Example 9', demonstrating the representation of MQL

3.2.8 Modificatory Quantifier (MQT)

Example 10

{Raw} Some people underestimate me.
 {Ann_{DSS}} CP_{some} [MQT] CP_{people} VT_{underestimate} RF_{me}
 {DSS}

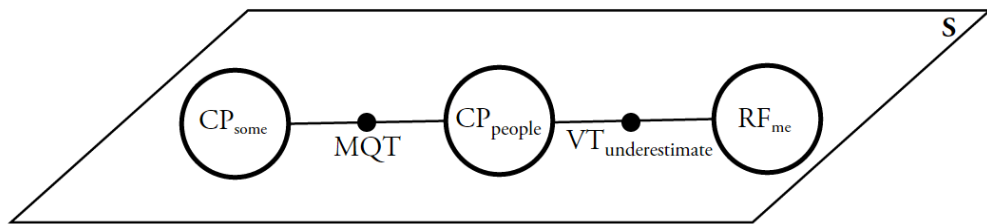

Figure 13. DSS of 'Example 10', demonstrating the representation of MQT

3.2.9 Modificatory Temporalizer (MTP)

Example 11

{Raw} Jane have been doing this for a long time.
 {Ann_{DSS}} CP_{Jane} MTP_{has_been_ing} VT_{do} RF_{this} PP_{for} SP_a CP_{long} [MQL] CP_{time}
 {DSS}

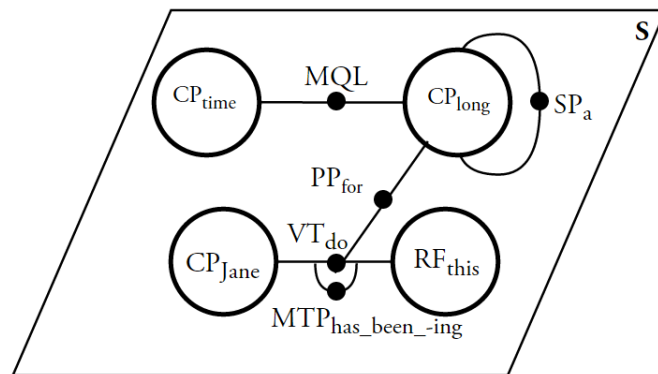

Figure 14. DSS of 'Example 11', demonstrating the representation of MTP

3.2.10 Inheritance (IN)

Example 12

{Raw} You are a filthy liar.
 {Ann_{DSS}} RF_{you} IN_{are_a} CP_{filthy} [MQL] CP_{liar}
 {DSS}

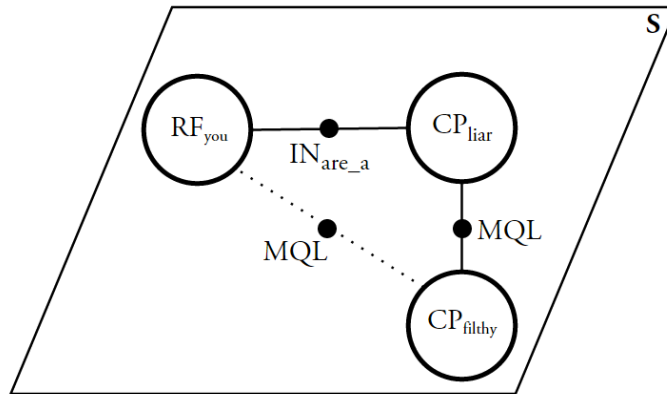

Figure 15. DSS of 'Example 12', demonstrating the representation of IN

3.2.11 Possessive (POS)

Example 13

{Raw} This is not our problem.
 {Ann_{DSS}} RF_{this} ID_{is} NEG_{not} POS_{our} [RF_{us}] CP_{problem}
 {DSS}

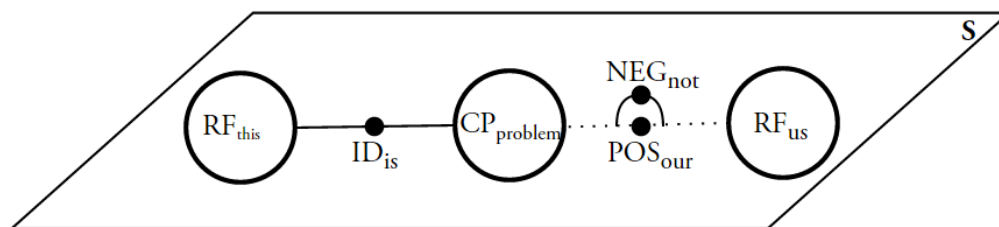

Figure 16. DSS of 'Example 13', demonstrating the representation of POS

3.2.12 Sample Discourse Analysis

In this final sub-section of ‘Section 3.2’, a fictional discourse that is composed of five sentences will be analyzed via DSS ontology and projected onto dynamic network structures, in order to provide a conclusive demonstration of how dynamic interpretation of linguistic expressions yield structures of increasing complexity both horizontally and vertically. For the sake of saving the time of the reader and the space here, the smallest scope of comprehension will be taken as the sentence level (i.e. a new state is generated by the comprehension of a new sentence) and MTPs will be disregarded such that all verbs will be included without further decomposing their TA. In addition, temporal and intentional focuses are also neglected, meaning all nodes and relations are active at all times.

{Raw} It was an exceptional night and the moon was rising for its glory. Two dark figures were walking in the shade. Their names were Gorgo and Horigu. Suddenly, Gorgo turned to Horigu and shouted “You are a coward!”, but he was wrong. She was different.

{Ann_{DSS}} RF_{it} ID_{was} SP_{an} CP_{exceptional} [MQL] CP_{night} CTP_{and} SP_{the} CP_{moon} VI_{was_rising} PP_{for} [RF_{it}] POS_{its} CP_{glory}. CP_{two} [MQT] CP_{dark} [MQL] CP_{figures} VI_{were_walking} PP_{in} SP_{the} CP_{shade}. [RF_{they}] POS_{their} CP_{names} ID_{were} CP_{Gorgo} CCO_{and} CP_{Horigu}. CP_{suddenly} [MQL] CP_{Gorgo} VI_{turned} PP_{to} CP_{Horigu} CTP_{and} VT_{shouted} RF_{you} IN_{are_a} CP_{coward} CCA_{but} RF_{he} IN_{was} CP_{wrong}. RF_{she} IN_{was} CP_{different}.

{DSS}

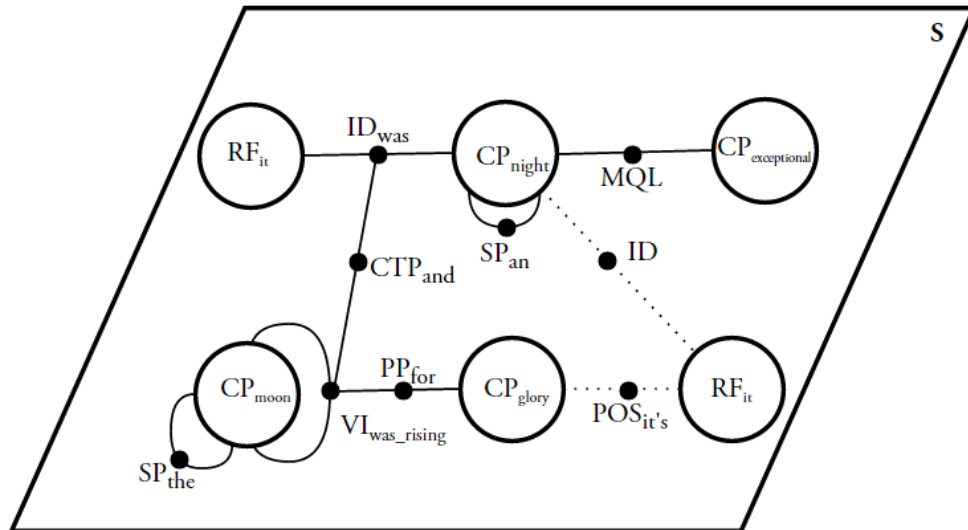

Figure 17. DSS of the first sentence of the discourse, or the initial state of the dynamic network, i.e. ‘state *i*’.

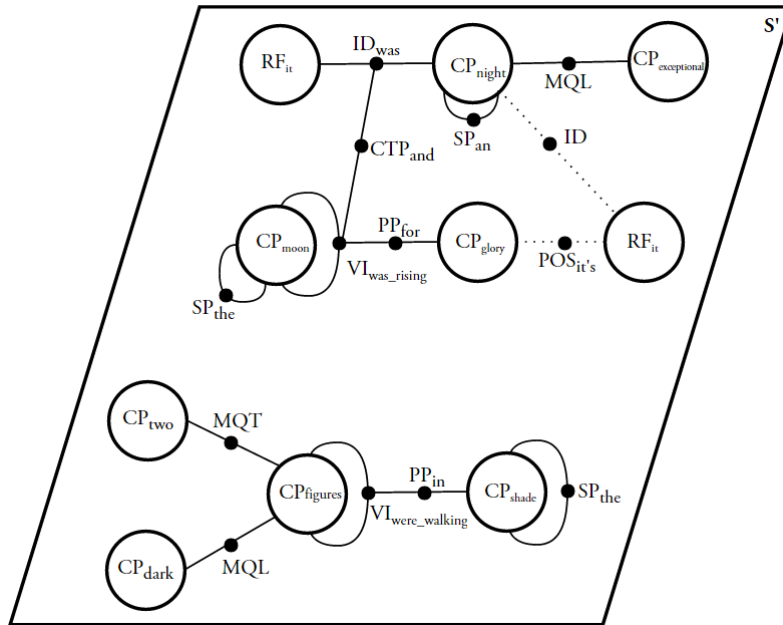

Figure 18. DSS of the first two sentences of the discourse, or the second state of the dynamic network, i.e. 'state 1'.

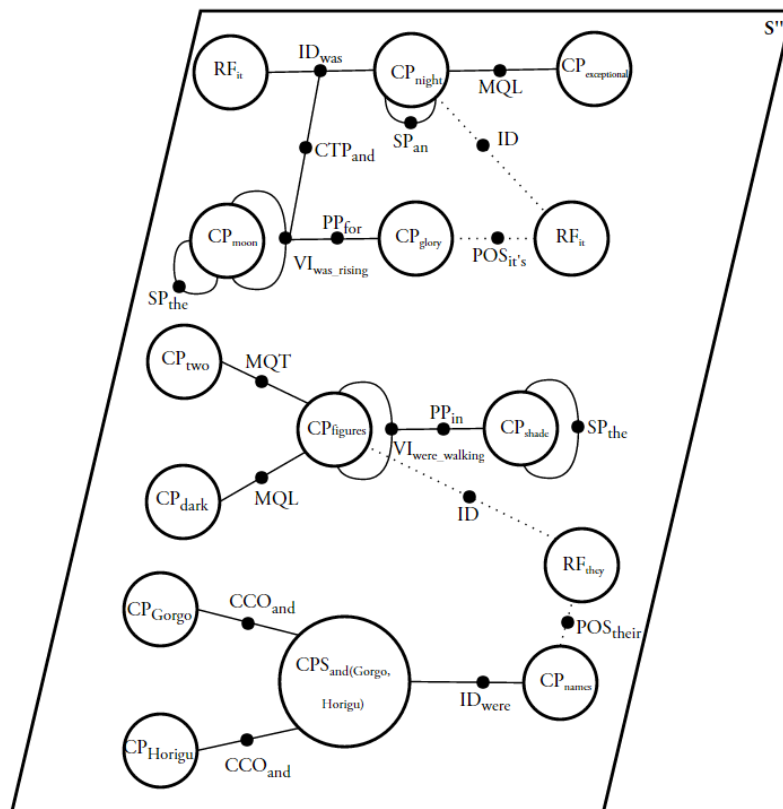

Figure 19. DSS of the first three sentences of the discourse, or the third state of the dynamic network, i.e. 'state 2'.

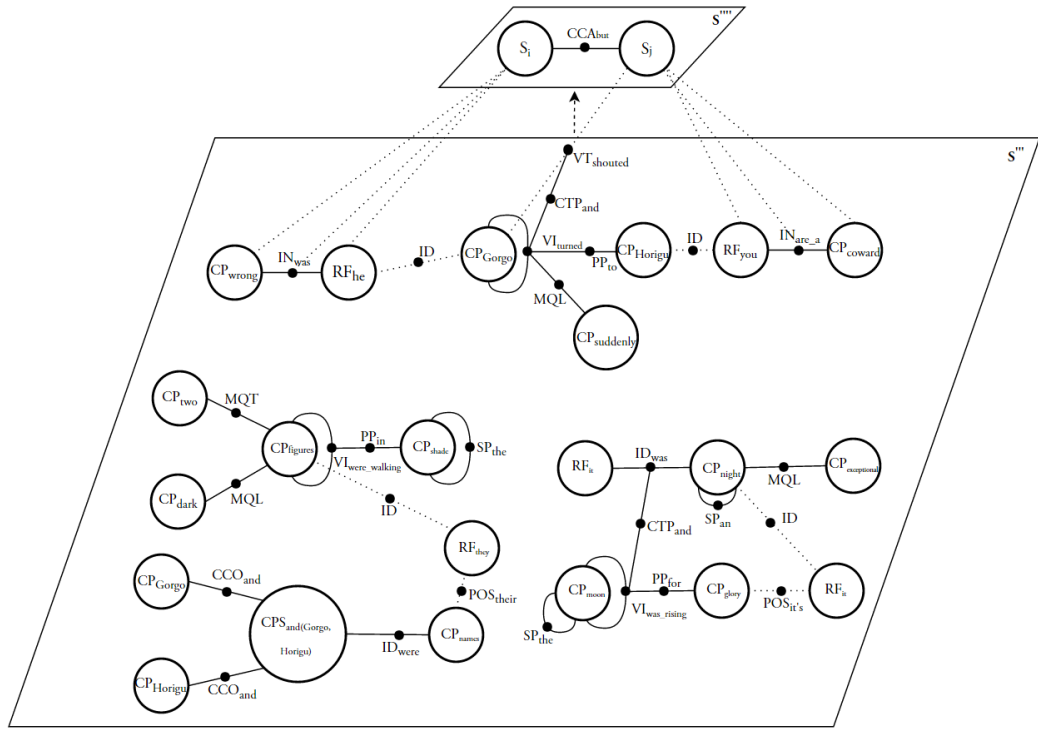

Figure 20. DSS of the first four sentences of the discourse, or the fourth state of the dynamic network, i.e. 'state 3'.

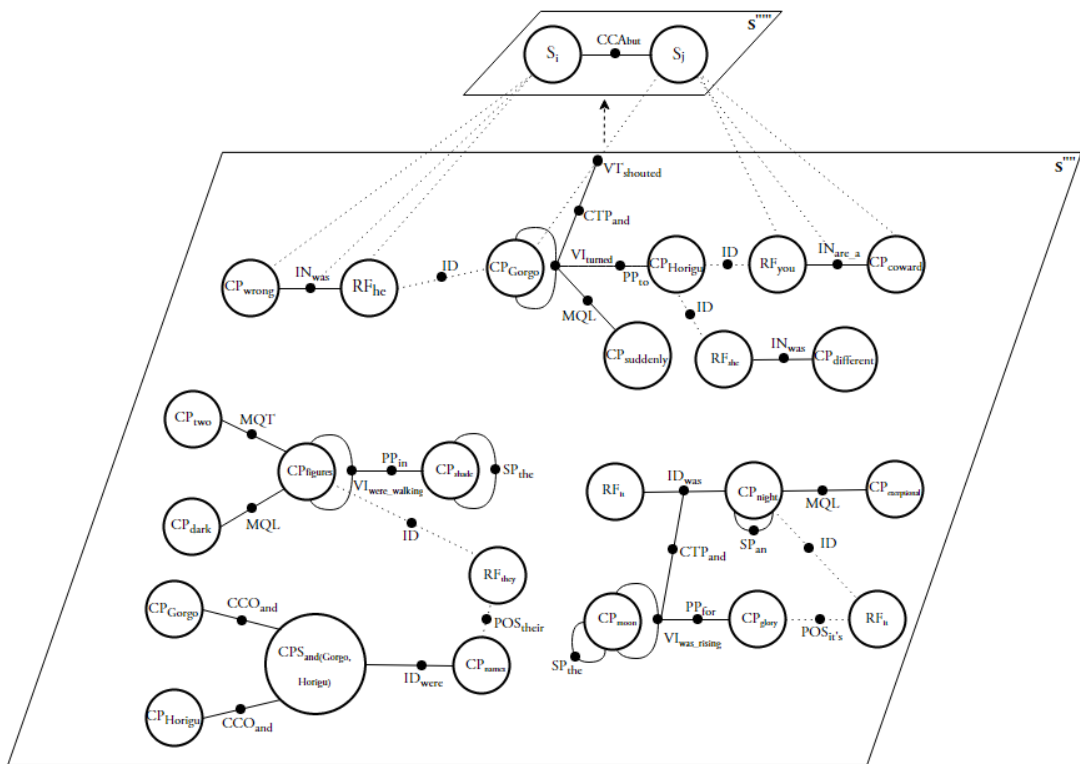

Figure 21. Complete DSS of the discourse, or the final state of the dynamic network, i.e. 'state f'.

3.3 The New Definition of Meaning

Within the CIS framework, *meaning* is conceived as linguistically symbolized, cognitively structured and dynamically evolving information. In that regard, the resulting semantic structure associated with a discourse segment can be conceived in terms of *local meaning* or *dynamic meaning*.

The meaning of a linguistic expression, whether it is a word, a sentence or a discourse segment, as long as it is contextually communicative, is defined by the totality of *active network* structures generated by it. An active network is a subset of the overall network generated from the introduction of first linguistic element that starts the communicative act until the last element, which ends the communication. The subset in mention is defined by the temporal extent of associated cognitive processes. There should be a critical period of activation for each element and relation to preserve computational efficiency of off-line processes (i.e. temporal focus) and to enable on-line shifts of focus (i.e. intentional focus). This is a crucial assumption required to model the network of active connections at a specific temporal period, which eventually determines the resulting internal information structure at that interval. We will call this temporally bounded state of cognitive information structure the *local meaning* of a discourse.

The meaning of a discourse can also be evaluated on a larger scale, as the complete meaning of a discourse from the start till end of the relevant communicative act. This is the *dynamic meaning* of a discourse; it corresponds to the full set of temporal network transitions and transformations during the process, i.e., the dynamic evolution of the network itself. A more specific description of dynamic meaning will be this: let M_{Li} be the corresponding local meaning of the initial state of the network structure that is the start of the discourse at the instant when comprehension initiates, M_{Lf} be the corresponding local meaning of the final state at the instant when comprehension terminates and M_{Ln} be the set of corresponding local meanings of the set of intermediate states that transform into each other throughout the comprehension process in the direction from M_{Li} to M_{Lf} . Note that M_L stands for the local meaning of a discourse and M_D stands for the dynamic meaning of a discourse. Based on this definition, M_D is equal to a dynamic network transition function, F_T , which takes all local meanings of the network evolution as its variables.

$$\begin{aligned} M_D &= F_T(M_{Li}, M_{Ln}, M_{Lf}) \\ M_{Ln} &= (M_{L1}, M_{L2}, \dots, M_{Lm}) \\ n &= m = \# \text{ of intermediate states} \end{aligned}$$

Equation 1. The definition of dynamic meaning, M_D , as a function, F_T , of local meanings, M_L

It is not that easy to explain the true nature of F_T without revealing the actual cognitive ontology of semantic information and properties of related semantic processes, but an attempt of its demonstration may be realized in terms of a dynamic simulation, where the dynamic evolution of the network is represented through state transformations based on two parameters, (i)

introduction of new nodes and relations to the network and (ii) temporal variations in the local activations of the existing nodes and relations in the network. Then, the overall simulation from the initial state of the network till the final may be conceived as a descriptive representation of the F_T , or more relevantly of the dynamic meaning of the target discourse, i.e. M_D .

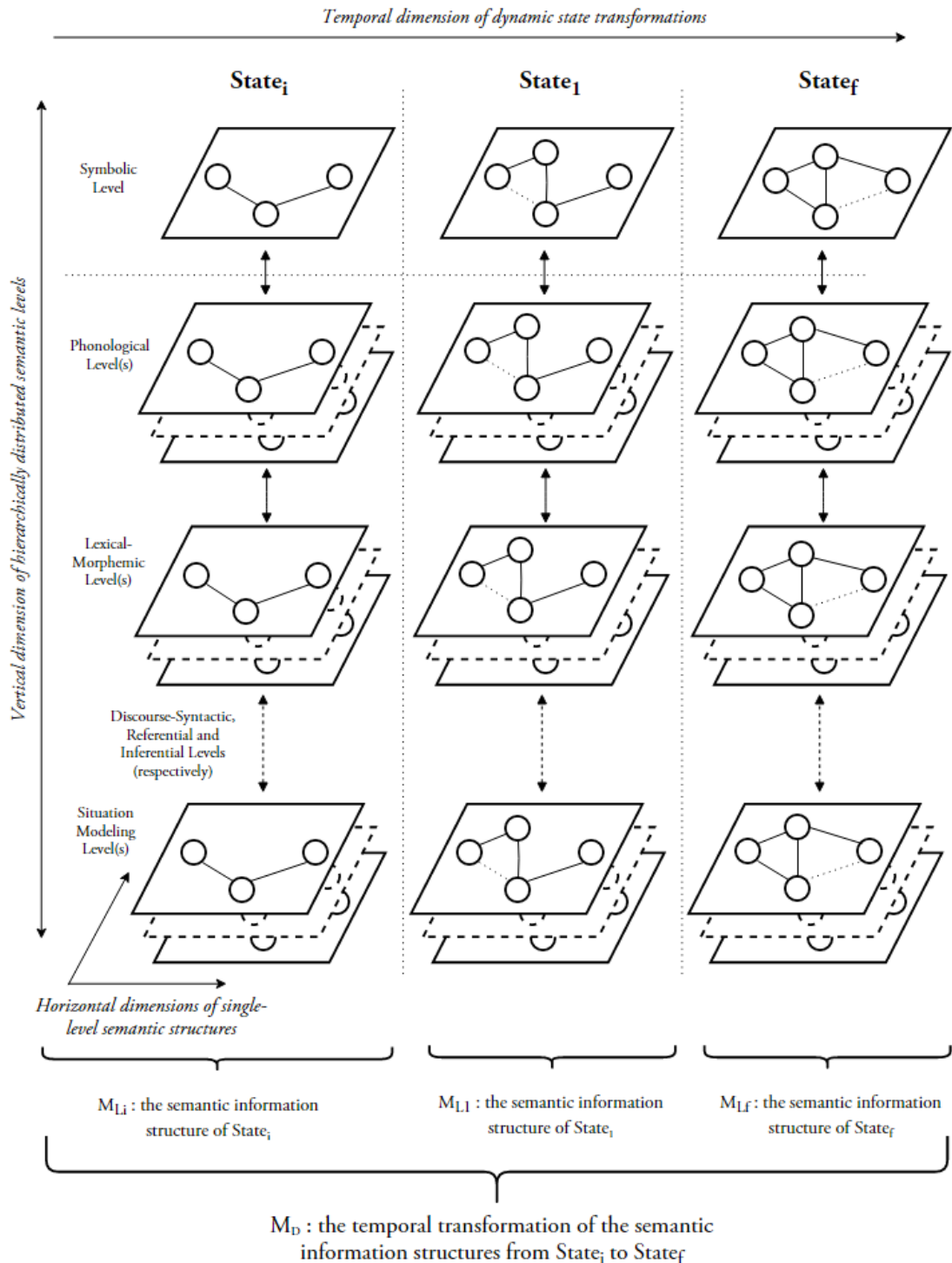

Figure 22. Local and dynamic meaning in a sample CIS, based on a three state semantic structure

CHAPTER 4

A SELF CRITICISM

The theoretical framework presented here, namely CIS, is intended as a holistic system of representation, which intrinsically involves various characteristics that are compatible with multi-dimensional, non-linear, set-theoretic, category-theoretic, image-schematic, and dynamic structures of information that seem to be involved in semantic processing.

The degree of elaboration submitted in this thesis is in direct relation with the complexity of the problem and the practical difficulties of adequately investigating it. This work does not claim to provide an explanatory theory; but instead an exploratory approach. It aims to introduce a ground on which linguistic meaning can be studied from a holistic perspective, taking into account different layers of conceptual structure simultaneously, as parts of a dynamically evolving system.

The necessary elaborations required for developing this exploratory approach into a working theory lies within several lines of scientific survey. First, an expressive calculus is required for revealing how relations bind nodes functionally, how complex structures are built in consequence and how those structures temporally evolve via dynamic state transformations. In parallel, an adequate ontology for explaining informational and structural properties of conceptual constructs is also needed. The properties of the network structure should be analyzed and enhanced accordingly if necessary, for gaining full capacity in representing the semantic structure revealed via these investigations. In order to explore the true character of dynamicity, neuro-linguistic explanations are required for modeling semantic processes realistically in terms of temporality. Empirical approaches based on data-driven, cross-linguistic analysis of the framework are also necessary in discovering the structural and representational limitations of CIS, its vulnerabilities to cross-linguistic variations and corresponding resolution strategies to overcome them. These instances of further scientific analysis detailed above reveal the fact that gaining an exploratory power on meaning is a matter of an interdisciplinary collaboration and requires contributions from various perspectives. Concordantly, the research program on elaborating and enhancing the CIS framework will continue as an open-ended project and any form of scientific participation will be most welcome.

FINAL REMARKS

Regarding the complexity and the difficulty of the problem, namely the pursuit of explaining linguistic meaning, any approach that aims to be comprehensive is threatened primarily by its own motivations in the first place. In line with the theoretical commitments of CIS framework, the overall enterprise of attempting to provide an adequate ontological and representational basis for modeling linguistic meaning ends up being bounded by the horizons of scientific enquiry, beyond which further dimensions of the unknown reality await. From this perspective, any theory of meaning including the humble attempt demonstrated by this thesis can claim at most an exploratory medium in which the scientist can only hope to encounter a gap, thorough which a chance of penetration may reveal itself into the question at hand.

At the end of the day, we are sure of at least two major obstacles about the semantics problem: (i) it is a problem of cognitive ontology and (ii) it is nearly immune to any scientific methodology, a combination of which yields many opposing fronts. Necessity of abstractions and related approaches seem to be telling us a story for some time, but they generally end up with being blocked by their own semantic illusions. Verificationists, on the other hand, are so strictly stipulating evidentiality, it may be better for them to leave the question aside until we have an adequate amount of data-oriented knowledge on how high-level cognitive processes work. In the meantime, and in between the radical ends, it is essential to try new ways of attacking the problem and see if it has a soft spot, which has been hidden from us for so long.

The central question to the pursuit of uncovering linguistic meaning has always been defining the true referent of the symbolic reference. It is of course important to propose fruitful possibilities that aim to fill that definition, but a complete attempt will aim to find a way of anchoring the term *reference* to a ground, which is comprehensive enough to cover all possible uses of natural language in the long run. As long as mind is the final destination, the study of the interface of language and meaning will continue to be an ontological hunt within the human cognitive system for a long time ahead, to which we should be prepared.

REFERENCES

- Aboitiz, F., García, R. R., Bosman, C., & Brunetti, E. (2006). Cortical memory mechanisms and language origins. *Brain and Language*, 98(1), 40–56.
- Anderson, J. R. (1983). A spreading activation theory of memory. *Journal of Verbal Learning and Verbal Behavior*, 22(3), 261-295.
- Anderson, S. E., Chiu, E., Huette, S., & Spivey, M. J. (2011). On the temporal dynamics of language-mediated vision and vision-mediated language. *Acta Psychologica*, 137(2), 181–189.
- Austin, J. L. (1975). *How to do things with words* (2nd ed.). J. O. Urmson & M. Sbisà (Eds.). Cambridge, MA: Harvard University Press.
- Baddeley, A. (2003). Working memory and language: An overview. *Journal of Communication Disorders*, 36(3), 189–208.
- Barsalou, L.W. (2008). Grounded cognition. *Annual Review of Psychology*, 59, 617–645.
- Barwise, J., & Perry, J. (1983). *Situations and attitudes*. Cambridge, MA: MIT Press
- Brugman, C., & Lakoff, G. (1988). Cognitive topology and lexical networks. In S. I Small, G. W. Cottrell & M. K. Tanenhaus (Eds.), *Lexical ambiguity resolution: Perspectives from psycholinguistics, neuropsychology and artificial intelligence* (pp. 477–508). San Mateo, CA: Morgan Kaufmann Publishers.
- Burke, D. M., & Mackay, D. G. (1997). Memory, language, and ageing. *Philosophical Transactions of the Royal Society of London. Series B, Biological Sciences*, 352(1363), 1845–1856.
- Carnap, R. (1931). Überwindung der metaphysik durch logische analyse der sprache. *Erkenntnis*, 2(1), 219–241.
- Carnap, R. (1956). *Meaning and necessity: A study in semantics and modal logic*. Chicago, IL: The University of Chicago Press.
- Carnap, R. (2002). *The logical syntax of language*. (A. Smeaton, Trans.). Chicago, IL: Open Court Publishing Company. (Original work published in 1937)

- Chomsky, N. (1956). Three models for the description of language. *IRE Transactions on Information Theory*, 2(3), 113-124.
- Chomsky, N. (1965). *Aspects of the theory of syntax*. Cambridge, MA: MIT Press.
- Chomsky, N. (1975). *The logical structure of linguistic theory*. New York, NY: Plenum Press.
- Clausner, T. C., & Croft, W. (1999). Domains and image schemas. *Cognitive Linguistics*, 10(1), 1-31.
- Cocchiarella, N. (1997). Continuity and change in the development of Russell's philosophy. *Journal of the History of Philosophy*, 35(1), 150-151.
- Collins, A. M., & Loftus, E. F. (1975). A spreading-activation theory of semantic processing. *Psychological Review*, 82(6), 407-428.
- Croft, W. (1993). The role of domains in the interpretation of metaphors and metonymies. *Cognitive Linguistics*, 4(4), 335-370.
- Davidson, D. (1967). Truth and meaning. *Synthese*, 17(3), 304-323.
- Davidson, D. (1970). Semantics for natural languages. In S. Nuccetelli & G. Seay (Eds.), *Philosophy of language: The central topics* (pp. 57-63). Lanham, MD: Rowman & Littlefield.
- Dehaene, S., Pegado, F., Braga, L. W., Ventura, P., Nunes Filho, G., Jobert, A., ... Cohen, L. (2010). How learning to read changes the cortical networks for vision and language. *Science*, 330(6009), 1359-1364.
- Demirşahin, Işın. (2015). *The discourse structure of Turkish* (Unpublished doctoral dissertation). Middle East Technical University, Ankara, Turkey.
- Evans, V. (2009). Semantic representation in LCCM Theory. In V. Evans & S. Pourcel (Eds.), *New directions in cognitive linguistics* (pp. 27-55). Amsterdam, NL: John Benjamins.
- Fauconnier, G. (1985). *Mental spaces*. Cambridge, MA: MIT Press
- Fauconnier, G. (1997). *Mappings in thought and language*. Cambridge, UK: Cambridge University Press.
- Fauconnier, G., & Turner, M. (1998). Conceptual integration networks. *Cognitive Science*, 22(2), 133-187.

- Ferreira, F., & Tanenhaus, M. K. (2007). Introduction to the special issue on language-vision interactions. *Journal of Memory and Language*, 57(4), 455–459.
- Feynman, R. P. (1974). Cargo cult science. *Engineering and Science*, 33, 10–13.
- Fillmore, J. C. (1982). Frame semantics. In The Linguistic Society of Korea (Ed.), *Linguistics in the morning calm: Selected papers from SICOL-1981* (pp. 111–137). Seoul, KR: Hanshin Publishing Company.
- Fillmore, C. J. (1988). The mechanisms of “construction grammar”. In S. Axmaker, A. Jaisser & H. Singmaster (Eds.), *Proceedings of the Fourteenth Annual Meeting of the Berkeley Linguistics Society* (pp. 35–55). Berkeley, CA: Berkeley Linguistic Society.
- Fillmore, C. J. (2006). Frame semantics. In E. K. Brown (Ed.), *Encyclopedia of language & linguistics* (2nd ed.) (pp. 613–620). Oxford, UK: Elsevier.
- Frege, G. (1892). Über Sinn und Bedeutung. *Zeitschrift Für Philosophie Und Philosophische Kritik*, 100, 25–50.
- Frege, G. (1979). Comments on sense and meaning. In H. Hermes, F. Kambartel & F. Kaulbach (Eds.), *Posthumous writings* (pp. 118–125). Chicago, IL: The University of Chicago Press.
- Gallese, V., & Lakoff, G. (2005). The brain’s concepts: the role of the sensory-motor system in conceptual knowledge. *Cognitive Neuropsychology*, 22(3), 455–479.
- Gathercole, S. E., & Baddeley, A. D. (1990). Phonological memory deficits in language disordered children: Is there a causal connection? *Journal of Memory and Language*, 29(3), 336–360.
- Gärdenfors, P. (2000). *Conceptual spaces: The geometry of thought*. Cambridge, MA: MIT Press.
- Gärdenfors, P. (2004). Conceptual spaces as a framework for knowledge representation. *Mind and Matter*, 2(2), 9–27.
- Geeraerts, D. (1989). Prospects and problems of prototype theory. *Linguistics*, 27(4), 587–612.
- Goldberg, A. E. (1992). The inherent semantics of argument structure: The case of the English ditransitive construction. *Cognitive Linguistics*, 3(1), 37–74.
- Goldberg, A. E. (2006). *Constructions at work: The nature of generalization in language*. Oxford, UK: Oxford University Press.

- Goldberg, A. E. (2009). The nature of generalization in language. *Cognitive Linguistics*, 20(1), 93-127.
- Goldberg, A. E., & Suttle, L. (2010). Construction grammar. *Wiley Interdisciplinary Reviews: Cognitive Science*, 1(4), 468-477.
- Grice, H. P. (1957). Meaning. *Philosophical Review*, 66, 377-388.
- Grice, H. P. (1969). Utterer's meaning and intention. *The Philosophical Review*, 78(2), 147-177.
- Grice, H. P. (1975). Logic and conversation. In P. Cole & J. L. Morgan (Eds.), *Syntax and Semantics* (pp. 41-58). Waltham, MA: Academic Press.
- Hager, P. J. (1994). *Continuity and change in the development of Russell's philosophy*. Dordrecht, NL: Kluwer Academic Publishers.
- Haugeland, J. (1996). What is mind design? In J. Haugeland (Ed.), *Mind Design II* (pp. 1-28). Cambridge, MA: MIT Press.
- Hobbs, J. R., Stickel, M. E., Appelt, D. E., & Martin, P. (1993). Interpretation as abduction. *Artificial Intelligence*, 63(1-2), 69-142.
- Jackendoff, R. (2003). Précis of foundations of language: Brain, meaning, grammar, evolution. *Behavioral and Brain Sciences*, 26(6), 651-665.
- Johnson, M. (1987). *The body in the mind: The bodily basis of meaning, imagination, and reason*. Chicago, IL: The University of Chicago Press.
- Johnson-Laird, P. N. (1983). *Mental models: Towards a cognitive science of language, inference, and consciousness*. Cambridge, MA: Harvard University Press.
- Kamp, H. (1981). A theory of truth and semantic representation. In J. Groenendijk, T. Janssen, & M. Stokhof (Eds.), *Formal methods in the study of language* (pp. 277-322). Amsterdam, NL: Mathematisch Centrum.
- Kamp, H., & Reyle, U. (1993). *From discourse to logic: Introduction to modeltheoretic semantics of natural language, formal logic and discourse representation theory*. Dordrecht, NL: Springer.

- Kana, R. K., Blum, E. R., Ladden, S. L., & Ver Hoef, L. W. (2012). "How to do things with words": Role of motor cortex in semantic representation of action words. *Neuropsychologia*, 50(14), 3403–3409.
- Katz, J. J. J., & Fodor, J. A. (1963). The structure of a semantic theory. *Language*, 39(2), 170–210.
- Katz, J. J., & P. M., Postal. (1964). *An integrated theory of linguistic descriptions*. Cambridge, MA: MIT Press.
- Klinger, M. R., Burton, P. C., & Pitts, G. S. (2000). Mechanisms of unconscious priming: I. Response competition, not spreading activation. *Journal of Experimental Psychology: Learning, Memory, and Cognition*, 26(2), 441–455.
- Kripke, S. (1971). Identity and necessity. *Identity and Individuation*, 2, 135–164.
- Kripke, S. (1975). Outline of a theory of truth. *The Journal of Philosophy*, 72(19), 690–716.
- Kripke, S. (1977). Speaker's reference and semantic reference. *Midwest Studies In Philosophy*, 2, 255–276.
- Kripke, S. (1980). *Naming and necessity*. Cambridge, MA: Harvard University Press.
- Lakoff, G. (1970). Linguistics and natural logic. *Synthese*, 22(1-2), 151–271.
- Lakoff, G. (1973). Hedges: A study in meaning criteria and the logic of fuzzy concepts. *Journal of Philosophical Logic*, 2(4), 458–508.
- Lakoff, G. (1987a). *Women, fire, and dangerous things: What categories reveal about the mind*. Chicago, IL: The University of Chicago Press.
- Lakoff, G. (1987b). Cognitive models and prototype theory. In Ulric Neisser (Ed.), *Concepts and conceptual development: Ecological and intellectual factors in categorization*. New York, NY: Cambridge University Press.
- Lakoff, G. (1992). The contemporary theory of metaphor. In A. Ortony (Ed.), *Metaphor and thought* (2nd ed.) (pp. 202–251). Cambridge, UK: Cambridge University Press.
- Lakoff, G. (2008). The neural theory of metaphor. In R. W. Gibbs (Ed.), *The Cambridge handbook of metaphor and thought* (pp. 17–38). Cambridge, UK: Cambridge University Press.

- Lakoff, G., & Johnson, M. (1980a). Conceptual metaphor in everyday language. *The Journal of Philosophy*, 77(8), 453–486.
- Lakoff, G., & Johnson, M. (1980b). The metaphorical structure of the human conceptual system. *Cognitive Science*, 4(2), 195–208.
- Lakoff, G., & Johnson, M. (1997). Metaphors we live by. In J. O'Brien & P. Kollock (Eds.), *The production of reality: essays and reading on social interaction* (2nd ed.) (pp. 124–134). Thousand Oaks, CA: SAGE Publications.
- Langacker, R. (1986). An introduction to cognitive grammar. *Cognitive Science*, 10(1), 1–40.
- Langacker, R. W. (1987). *Foundations of cognitive grammar: Theoretical prerequisites* (Vols. 1–2). Stanford, CA: Stanford University Press.
- Langacker, R. W. (1991). *Foundations of cognitive grammar: Descriptive application* (Vols. 2–2). Stanford, CA: Stanford University Press.
- Langacker, R. W. (2001). Dynamicity in grammar. *Axiomathes*, 12, 7–33.
- Lascarides, A., & Asher, N. (2003). Segmented discourse representation theory: Dynamic semantics with discourse structure. *Computing Meaning*, 3, 87–124.
- Locke, J. (1975). *An essay concerning human understanding*. P. H. Nidditch (Ed.). Oxford, UK: Oxford University Press. (Original work published in 1690)
- Mill, J. S. (1843). *A system of logic, ratiocinative and inductive*. New York, NY: Harper & Brothers.
- Miller, G. A. (2003). The cognitive revolution: A historical perspective. *Trends in Cognitive Sciences*, 7(3), 141–144.
- Mishra, R. K., & Marmolejo-Ramos, F. (2010). On the mental representations originating during the interaction between language and vision. *Cognitive Processing*, 11(4), 295–305.
- Montague, R. (1970). Universal grammar. *Theoria*, 36(3), 373–398.
- Montague, R. (1973). The proper treatment of quantification in ordinary English. *Approaches to Natural Language*, 49, 221–242.
- Montague, R. (1974). *Formal philosophy: Selected papers of Richard Montague*. R. H. Thomason (Ed.). New Haven, CT: Yale University Press.

- Partee, B. H. (2014). A brief history of the syntax-semantics interface in Western formal linguistics. *Semantics-Syntax Interface 1*(1), 1–21.
- Ramsey, F. P., & Moore, G. E. (1927). Facts and propositions. *Proceedings of the Aristotelian Society, Supplementary Volumes*, 7, 153–206.
- Rosch, E. (1975a). Cognitive reference points. *Cognitive Psychology*, 7(4), 532–547.
- Rosch, E. (1975b). Cognitive representations of semantic categories. *Journal of Experimental Psychology: General*, 104(3), 192–233.
- Rosch, E. (1978). Principles of categorization. In E. Rosch & B. B. Lloyd (Eds.), *Cognition and categorization* (pp. 27–48). Hillsdale, NJ: Lawrence Erlbaum Associates.
- Russell, B. (1905). On denoting. *Mind, New Series*, 14(56), 479–493.
- Russell, B. (1911). Knowledge by acquaintance and knowledge by description. *Proceedings of the Aristotelian Society*, 11, 108–128.
- Russell, B. (1919). On propositions: What they are and how they mean. *Proceedings of the Aristotelian Society, Supplementary Volumes*, 2, 1–43.
- Schank, R. (1980). Language and memory. *Cognitive Science*, 4(3), 243–284.
- Searle, J. R. (1958). Proper names. *Mind*, 67(266), 166–173.
- Searle, J. R. (1965). What is a speech act? In M. Black (Ed.), *Philosophy in America* (pp. 221–239). London, UK: Allen & Unwin.
- Searle, J. R. (1976). A classification of illocutionary acts. *Language in Society*, 5(1), 1–23.
- Searle, J. R., & Vanderveken, D. (1985). *Foundations of illocutionary logic*. Cambridge, UK: Cambridge University Press.
- Simon, H. A. (1996). *The sciences of the artificial* (3rd ed.). Cambridge, MA: MIT Press.
- Sperber, D., & Wilson, D. (1986). *Relevance: Communication and cognition*. Cambridge, MA: Harvard University Press.
- Strawson, P. F. (1950). On referring. *Mind, New Series*, 59(235), 320–344.
- Strawson, P. F. (1952). *Introduction to logical theory*. London, UK: Methuen.

- Talmy, L. (1988a). Force dynamics in language and cognition. *Cognitive Science*, 12(1), 49–100.
- Talmy, L. (1988b). The relation of grammar to cognition. In B. Rudzka-Ostyn (Ed.), *Topics in cognitive linguistics* (pp. 165-205). Amsterdam, NL: John Benjamins.
- Talmy, L. (2000a). *Toward a cognitive semantics: Concept structuring systems* (Vols. 1–2). Cambridge, MA: MIT Press.
- Talmy, L. (2000b). *Toward a cognitive semantics: Typology and process in concept structuring* (Vols. 2–2). Cambridge, MA: MIT Press.
- Tarski, A. (1944). The semantic conception of truth and the foundations of semantics. *Philosophy and Phenomenological Research*, 4(3), 341–376.
- Temürcü, C. (2007). *A semantic framework for analyzing tense, aspect and mood: An application to the ranges of polysemy of -Xr, -Dir, -Iyor and -Ø in turkish* (Unpublished doctoral dissertation). University of Antwerp, Antwerpen, Belgium.
- Temürcü, C. (2011). Grounding in terms of anchoring relations: Epistemic associations of “present continuous” marking in Turkish. In A. Patard & F. Brisard (Eds.), *Cognitive approaches to tense, aspect, and epistemic modality* (pp. 109–134). Amsterdam, NL: John Benjamins.
- Tuggy, D. (1993). Ambiguity, polysemy, and vagueness. *Cognitive Linguistics* 4(3): 273–290.
- Wittgenstein, L. (1922). *Tractatus logico-philosophicus*. London, UK: Kegan Paul, Trench, Trübner & Co.
- Wittgenstein, L. (2010). *Philosophical investigations*. (G. E. M. Anscombe, P. M. S. Hacker, & J. Schulte, Trans.). Hoboken, NJ: John Wiley & Sons. (Original work published in 1953)
- Zwaan, R. A., & Radvansky, G. A. (1998). Situation models in language comprehension and memory. *Psychological Bulletin*, 123(2), 162–185.