

THE INFLUENCE OF MODULARITY REPRESENTATION AND
PRESENTATION MEDIUM ON THE UNDERSTANDABILITY OF
BUSINESS PROCESS MODELS

A THESIS SUBMITTED TO
THE GRADUATE SCHOOL OF INFORMATICS OF
THE MIDDLE EAST TECHNICAL UNIVERSITY

BY

AHMET DİKİCİ

IN PARTIAL FULFILLMENT OF THE REQUIREMENTS FOR THE DEGREE OF
DOCTOR OF PHILOSOPHY

IN

THE DEPARTMENT OF INFORMATION SYSTEMS

AUGUST 2016

THE INFLUENCE OF MODULARITY REPRESENTATION AND
PRESENTATION MEDIUM ON THE UNDERSTANDABILITY OF
BUSINESS PROCESS MODELS

Submitted by Ahmet Dikici in partial fulfillment of the requirements for the degree of
Doctor of Philosophy in Information Systems, Middle East Technical University by,

Prof. Dr. Nazife Baykal
Director, **Graduate School of Informatics**

Prof. Dr. Yasemin Yardımcı Çetin
Head of Department, **Information
Systems**

Prof. Dr. Onur Demirörs
Supervisor, **Information Systems**

Assist. Prof. Dr. Oktay Türetken
Co-Supervisor, **Information Systems,
Eindhoven University of Technology**

Examining Committee Members:

Prof. Dr. Ali Doğru
Computer Engineering, METU

Prof. Dr. Onur Demirörs
Information Systems, METU

Prof. Dr. Semih Bilgen
Computer Engineering, Yeditepe University

Assoc. Prof. Dr. Altan Koçyiğit
Information Systems, METU

Assist. Prof. Dr. Barış Özkan
Information Systems Engineering, Atılım
University

Date: 24.08.2016



I hereby declare that all information in this document has been obtained and presented in accordance with academic rules and ethical conduct. I also declare that, as required by these rules and conduct, I have fully cited and referenced all material and results that are not original to this work.

Name, Last name : Ahmet Dikici

Signature : _____

ABSTRACT

THE INFLUENCE OF MODULARITY REPRESENTATION AND PRESENTATION MEDIUM ON THE UNDERSTANDABILITY OF BUSINESS PROCESS MODELS

Dikici, Ahmet

Ph.D., Department of Information Systems

Supervisor: Prof. Dr. Onur Demirörs

Co-Supervisor: Assist. Prof. Dr. Oktay Türetken

August 2016, 200 pages

Many factors influence the creation of understandable business process models for an appropriate audience. Understandability of process models becomes critical particularly when a process is complex and its model is large in structure. Using modularization to represent such models hierarchically (e.g. using sub-processes) is considered to contribute to the understandability of these models. To investigate this assumption, we conducted a family of controlled experiments with participation of 115 practitioners and 140 students. Our experimental material involved 2 large-scale real-life business process models that were modeled using BPMN v2.0 (Business Process Model and Notation). Each process was modeled in 3 modularity forms: fully-flattened, flattened where activities are clustered using BPMN groups, and modularized using separately viewed BPMN sub-processes. The objective is to examine if and how different forms of modularity representation in BPMN collaboration diagrams influence the understandability of process models. In addition to the forms of modularity representation, we also looked into the presentation medium (paper vs. computer) as a factor that potentially influences model comprehension. The results of our experiments indicate that for business practitioners, to optimally understand a BPMN model in the form of a collaboration diagram, it is recommended to present the model in ‘flattened’ forms (with or without the use of groups) in the ‘paper’ format. Results of our study can be used to develop process modeling guidelines based on empirical findings. Moreover, findings of our systematic literature review will provide insights for practitioners who aim to generate understandable process models.

Keywords: Business process model, understandability, modularity, BPMN, sub-process

ÖZ

MODÜLERLİK GÖSTERİMİ VE SUNUM ORTAMININ İŞ SÜRECİ MODELLERİNİN ANLAŞILABİLİRLİĞİNE ETKİSİ

Dikici, Ahmet

Doktora, Bilişim Sistemleri Bölümü

Tez Yöneticisi: Prof. Dr. Onur Demirörs

Ortak Tez Yöneticisi: Yrd. Doç. Dr. Oktay Türetken

Ağustos 2016, 200 sayfa

Hedef kitle için anlaşılabilir iş süreci modellerinin oluşturulmasını birçok faktör etkilemektedir. Özellikle bir süreç karmaşık olduğunda ve onun modeli yapısal olarak büyüdüğünde, o süreç modelinin anlaşılabilirliği kritik hale gelir. Modülerlik uygulanarak böyle modelleri hiyerarşik (örneğin alt süreçler kullanarak) göstermenin bu modellerin anlaşılabilirliğine katkı yaptığı kabul edilir. Bu varsayımı araştırmak için, 115 pratisyen ve 140 öğrencinin katılımı ile kontrollü deneyler gerçekleştirdik. Deney materyallerimiz, BPMN v2.0 (Business Process Model and Notation) ile modellenmiş iki tane büyük ölçekli ve gerçek hayatta uygulanan iş süreci modeli içermektedir. Her bir süreç, üç modülerlik formu kullanılarak modellenmiştir: tam bütüncül, aktivitelerin BPMN grupları ile kümelendiği bütüncül ve ayrı görüntülenen BPMN alt süreçlerinin kullanıldığı modüler form. Amaç, BPMN işbirliği (collaboration) diyagramlarındaki çeşitli modülerlik gösterimlerinin süreç modellerinin anlaşılabilirliğini etkileyip etkilemediğini ve nasıl etkilediğini incelemektir. Modülerlik gösterimi formlarına ek olarak, model anlaşılabilirliğini potansiyel olarak etkileyen sunum ortamını (bilgisayar veya kağıt) da bir faktör olarak inceledik. Deneylerin sonuçları, pratisyenlerin en ideal olarak bir işbirliği diyagramı formatındaki BPMN modelini anlaması için modelin ‘bütüncül’ formlarda (grup kullanmak veya kullanmaksızın) ‘kağıt’ ortamında sunulmasının önerildiğini göstermektedir. Çalışmamızın sonuçları, ampirik bulgulara dayanan süreç modelleme kılavuzlarının geliştirilmesinde kullanılabilir. Ayrıca, sistematik literatür taramamızın bulguları anlaşılabilir süreç modeli oluşturmayı amaçlayan pratisyenler için kazanımlar sağlayacaktır.

Anahtar Sözcükler: İş süreci modeli, anlaşılabilirlik, modülerlik, BPMN, alt süreç



To Maya

ACKNOWLEDGMENTS

Firstly, I would like to express my sincere gratitude to my supervisor Dr. Onur Demirrs, who also introduced me to process modeling, for his wisdom, insight, encouragement and continuous support throughout this study. His guidance helped me in all the time of my study. He provided me the chance to complete my dissertation.

I owe my co-supervisor Dr. Oktay Tretken a huge debt of gratitude for being a wonderful advisor and mentor to me. Words cannot express my appreciation for all that he has done. I thank him for many hours and weekends he has spent with me, for answering my questions and discussing my study, and even for his hospitality in Eindhoven, Netherlands. I would have been lost without his invaluable guidance. His knowledge, enthusiasm and commitment to the highest research standards inspired and motivated me. I am very proud for having received – and taken advantage of – the opportunity of working with him. From the beginning, I felt that I am privileged to be his student.

I would like to thank my thesis monitoring committee members Dr. Ali Dođru and Dr. Altan Koyiđit for their guidance and feedback throughout the last few years. I would also like to thank my examining committee members Dr. Semih Bilgen and Dr. Barıř zkan for reading my dissertation and their valuable comments.

My sincere thanks also go to Dr. Uzak Kaymak and the management team of Information Systems research group in the School of Industrial Engineering at Eindhoven University of Technology, who provided me an opportunity to be a part of research activities being conducted there. I truly appreciate Tessa Rompen for her work in master thesis which gave an insight into my research problem and I would like to thank her.

It took approximately one hour to complete the questionnaire in our experiment. I am very grateful to totally 255 professionals and students from both Netherlands and Turkey who contributed to this research by participating to our experiments. My studies would be inconclusive without the collaboration of them. I would also like to thank my colleagues Turan Bahattin zen and Onur Erdođan who have encouraged me even at my difficult times at work for moral support.

I would like to thank my mother Nurten Dikici, my father Blent Dikici and my brother Aydın Dikici for supporting me throughout not only in my study but in my life general and for their unconditional love, care, trust and continuous support. They were always there when I needed. I would express my gratitude to my parents-in-law for their understanding.

And finally, I would like to express my deepest gratitude to my wife Figen for her love, never-ending support and patience, particularly over the countless weekends and weeknights I left her alone with our new family member; Maya. Thank you for being with me and believing in me. I dedicate this dissertation to Maya, who not only survived to grow up without me around her at times, but for a wish that she will contribute to humankind one day at a time. She gives me happiness, hope and light. I hope that I am as inspirational to her as she is to me.

TABLE OF CONTENTS

ABSTRACT.....	iv
ÖZ.....	v
DEDICATION.....	vi
ACKNOWLEDGMENTS.....	vii
TABLE OF CONTENTS.....	viii
LIST OF TABLES.....	xi
LIST OF FIGURES.....	xiii
LIST OF ABBREVIATIONS.....	xvi
CHAPTERS	
1 INTRODUCTION.....	1
1.1 Background of the Problem.....	2
1.2 Statement of the Problem.....	4
1.3 Research Strategy.....	6
1.4 Structure of the Thesis.....	7
2 LITERATURE REVIEW.....	9
2.1 Systematic Literature Review Design.....	11
2.2 Structure of the Extracted Research Data.....	14
2.3 General Findings.....	15
2.4 Process Model Understandability Indicators in the Literature.....	17
2.5 Factors Investigated in Primary Studies.....	19
2.5.1 Process Model Factors.....	23
2.5.2 Personal Factors.....	31
2.6 Discussion.....	34
2.7 Conclusion.....	37
3 RESEARCH METHODOLOGY.....	39
3.1 Research Model.....	40
3.2 Process Models Used for the Experiment.....	43
3.3 Forms of Modularity Representation.....	44
3.4 Presentation Medium for the Process Models.....	46
3.5 Understandability Questions.....	47
3.6 Dependent Variables.....	48

3.7	Experiment Blocks.....	50
3.8	Questionnaire.....	50
3.9	Participants.....	51
4	RESULTS AND DISCUSSIONS.....	55
4.1	Data Preparation and Assumptions.....	55
4.2	Descriptive Statistics.....	56
4.2.1	Descriptive Statistics for Participants' Background Characteristics	56
4.2.2	Descriptive Statistics for Dependent Variables	59
4.2.3	Correlation Analysis	63
4.3	Checking Assumptions of the Statistical Tests.....	65
4.4	Hypotheses Testing.....	67
4.4.1	Testing the Hypotheses on the Forms of Modularity Representation.....	68
4.4.2	Testing the Hypotheses on the Presentation Medium.....	70
4.4.3	Testing the Hypotheses on Experience with Process Models.....	71
4.4.4	Testing the Hypotheses on Intensity of Working with Process Models	71
4.4.5	Testing the Hypotheses on Familiarity with Process Domain.....	72
4.4.6	Testing the Hypotheses on BP Modeling Knowledge	72
4.4.7	Testing the Hypotheses on BPMN 2.0 Knowledge	72
4.4.8	Testing the Hypotheses on Theoretical Knowledge on BP Modeling and BPMN 2.0	72
4.5	Discussion.....	73
4.5.1	Discussing the Effect of Modularity Representation	74
4.5.2	Discussing the Effect of Presentation Medium.....	77
4.5.3	Discussing the Effect of Experience with Process Models.....	77
4.5.4	Discussing the effect of Intensity of Working with Process Models.....	78
4.5.5	Discussing the Effect of Familiarity with Process Domain.....	78
4.5.6	Discussing the Effect of BP Modeling Knowledge	79
4.5.7	Discussing the Effect of BPMN 2.0 Knowledge	79
4.5.8	Discussing the Effect of Theoretical Knowledge on BP Modeling and BPMN 2.0	80
4.5.9	Differences in the Experiments.....	81
4.5.10	Influence of Using Different Process Models.....	85
5	CONCLUSION.....	89
5.1	Threats to Validity	90
5.2	Limitations and Future Work.....	92
5.3	Implications for Research and Practice.....	93

REFERENCES	95
APPENDICES	109
APPENDIX A: PRIMARY STUDIES	109
APPENDIX B: PROCESS MODELS	113
APPENDIX C: PROCESS MODELING CONVENTIONS	126
APPENDIX D: QUESTIONNAIRE.....	127
APPENDIX E: ASSUMPTIONS	145
APPENDIX F: THE INFLUENCE OF MODULARITY REPRESENTATION.....	158
APPENDIX G: THE INFLUENCE OF PRESENTATION MEDIUM	169
APPENDIX H: THE INFLUENCE OF EXPERIENCE WITH PROCESS MODELS	173
APPENDIX I: THE INFLUENCE OF INTENSITY OF WORKING WITH PROCESS MODELS	174
APPENDIX J: THE INFLUENCE OF FAMILIARITY WITH PROCESS DOMAIN.....	181
APPENDIX K: THE INFLUENCE OF BP MODELING KNOWLEDGE.....	182
APPENDIX L: THE INFLUENCE OF BPMN 2.0 KNOWLEDGE	186
APPENDIX M: THE INFLUENCE OF THEORETICAL KNOWLEDGE ON BP MODELING AND BPMN 2.0	192
APPENDIX N: DIFFERENCES IN THE EXPERIMENTS.....	195
APPENDIX O: THE INFLUENCE OF USING DIFFERENT PROCESS MODELS	198
CURRICULUM VITAE	200

LIST OF TABLES

Table 1 Process modeling notations used in primary studies	17
Table 2 Process model understandability indicators and related primary studies	18
Table 3 Factors investigated in primary studies	22
Table 4 Structural properties of process model A and process model B	44
Table 5 Distribution of understandability questions for <i>process model A</i>	48
Table 6 Distribution of understandability questions for <i>process model B</i>	48
Table 7 Experimental block-design	50
Table 8 Descriptive statistics - understandability task effectiveness	60
Table 9 Descriptive statistics - understandability task efficiency	61
Table 10 Descriptive statistics - perceived usefulness for understandability	62
Table 11 Descriptive statistics - perceived ease of understanding	63
Table 12 Correlation matrix between external variables	64
Table 13 Normality test results	67
Table 14 Results of the Kruskal-Wallis statistical tests	68
Table 15 Summary of hypotheses testing	74
Table 16 Comparison of effects of modularity representation on understandability	77
Table 17 Comparison of effects of experience with process models on understandability	78
Table 18 Comparison of effects of intensity of working with process models on understandability	78
Table 19 Comparison of effects of familiarity with process domain on understandability	79
Table 20 Comparison of effects of BP modeling knowledge on understandability	79
Table 21 Comparison of effects of BPMN 2.0 knowledge on understandability	80
Table 22 Comparison of effects of theoretical knowledge on BP modeling and BPMN 2.0 on understandability	81
Table 23 Results of the Kruskal-Wallis statistical tests for H1 by experiment	81
Table 24 Results of the Kruskal-Wallis statistical tests for H2 by experiment	82
Table 25 Results of the Kruskal-Wallis statistical tests for H3 by experiment	82
Table 26 Results of the Kruskal-Wallis statistical tests for H4 by experiment	83
Table 27 Results of the Kruskal-Wallis statistical tests for H5 by experiment	83
Table 28 Results of the Kruskal-Wallis statistical tests for H6 by experiment	84
Table 29 Results of the Kruskal-Wallis statistical tests for H7 by experiment	84
Table 30 Results of the Kruskal-Wallis statistical tests for H8 by experiment	85
Table 31 Descriptive statistics (process based) - understandability task effectiveness	86
Table 32 Descriptive statistics (process based) - understandability task efficiency	86
Table 33 Results of the Kruskal-Wallis statistical tests for H1 by process	87
Table 34 Results of the Kruskal-Wallis statistical tests for H2 by process	88
Table 35 Process modeling conventions	126
Table 36 Kruskal-Wallis test results for understandability variables by modularity representation	158
Table 37 Kruskal-Wallis test results for further analysis of understandability task effectiveness by modularity representation	159
Table 38 Homogeneous subsets of understandability task effectiveness (local) by modularity representation	162

Table 39 Kruskal-Wallis test results for further analysis of understandability task efficiency by modularity representation	166
Table 40 Kruskal-Wallis test results for understandability variables by presentation medium	169
Table 41 Kruskal-Wallis test results for understandability variables by experience with process models	173
Table 42 Kruskal-Wallis test results for understandability variables by intensity of working with process models	174
Table 43 Homogeneous subsets of understandability task efficiency by intensity of working with process models	177
Table 44 Homogeneous subsets of perceived ease of understanding by intensity of working with process models	180
Table 45 Kruskal-Wallis test results for understandability variables by familiarity with domain	181
Table 46 Kruskal-Wallis test results for understandability variables by BP modeling knowledge	182
Table 47 Homogeneous subsets of understandability task efficiency by BP modeling knowledge	185
Table 48 Kruskal-Wallis test results for understandability variables by BPMN 2.0 knowledge	186
Table 49 Homogeneous subsets of perceived ease of understanding by BPMN 2.0 knowledge	191
Table 50 Kruskal-Wallis test results for understandability variables by theoretical knowledge on BP modeling and BPMN 2.0	192

LIST OF FIGURES

Figure 1 SLR steps and resulting number of publications	12
Figure 2 Distribution of primary studies by year	15
Figure 3 Distribution of primary studies by publication type	16
Figure 4 Number of participants in experiments and distribution of participants (the number of experiment participants is not provided in [S36])	16
Figure 5 Process model understandability reference model	20
Figure 6 Factors and number of studies that investigate those factors	21
Figure 7 Research design	40
Figure 8 Research model	41
Figure 9 Three modularity representations: <i>a</i>) Fully-flattened [Repr1], <i>b</i>) Flattened view with groups [Repr2], and <i>c</i>) Sub-processes collapsed and shown in separate models [Repr3]	45
Figure 10 The process models in two forms of modularity representation: <i>a</i>) <i>Process A</i> in <i>Repr2</i> (flattened with groups of activities), <i>b</i>) <i>Process B</i> in <i>Repr3</i> (with collapsed sub-processes), <i>c</i>) Few of the <i>sub-process models</i> of <i>Process B</i> in <i>Repr3</i>	46
Figure 11 Parts of experiment	51
Figure 12 Distributions of participants by block in each experiment	52
Figure 13 Distribution of participants by block	52
Figure 14 Participants' level of experience with process models	56
Figure 15 Participants' rate of encountering process models in practice	57
Figure 16 Participants' level of domain familiarity	57
Figure 17 Participants' level of knowledge on process modeling	58
Figure 18 Participants' level of knowledge on BPMN 2.0	58
Figure 19 Boxplot graphs for understandability task effectiveness	60
Figure 20 Boxplot graphs for understandability task efficiency	61
Figure 21 Boxplot graphs for perceived usefulness for understandability	62
Figure 22 Boxplot graphs for perceived ease of understanding	63
Figure 23 Normality test results for understandability task effectiveness	145
Figure 24 Normality test results for understandability task effectiveness (local)	145
Figure 25 Normality test results for understandability task effectiveness (global)	146
Figure 26 Normality test results for understandability task effectiveness (local-only)	146
Figure 27 Normality test results for understandability task effectiveness (global-only)	147
Figure 28 Normality test results for understandability task effectiveness (global and local)	147
Figure 29 Normality test results for understandability task effectiveness (control flow)	148
Figure 30 Normality test results for understandability task effectiveness (resource)	148
Figure 31 Normality test results for understandability task effectiveness (information)	149
Figure 32 Normality test results for understandability task effectiveness (control flow-only)	149
Figure 33 Normality test results for understandability task effectiveness (resource and information)	150
Figure 34 Normality test results for understandability task effectiveness (control flow, resource and information)	150
Figure 35 Normality test results for understandability task efficiency	151
Figure 36 Normality test results for understandability task efficiency (local)	151

Figure 37 Normality test results for understandability task efficiency (global)	152
Figure 38 Normality test results for understandability task efficiency (local-only)	152
Figure 39 Normality test results for understandability task efficiency (global-only).....	153
Figure 40 Normality test results for understandability task efficiency (global and local)....	153
Figure 41 Normality test results for understandability task efficiency (control flow)	154
Figure 42 Normality test results for understandability task efficiency (resource).....	154
Figure 43 Normality test results for understandability task efficiency (information)	155
Figure 44 Normality test results for understandability task efficiency (control flow-only) .	155
Figure 45 Normality test results for understandability task efficiency (resource and information only)	156
Figure 46 Normality test results for understandability task efficiency (control flow, resource and information).....	156
Figure 47 Normality test results for perceived usefulness for understandability	157
Figure 48 Normality test results for perceived ease of understanding.....	157
Figure 49 Independent samples test view of modularity representation - understandability task effectiveness (local).....	160
Figure 50 Pairwise comparisons of understandability task effectiveness (local) by modularity representation.....	161
Figure 51 Independent samples test view of modularity representation - understandability task effectiveness (local-only)	162
Figure 52 Pairwise comparisons of understandability task effectiveness (local-only) by modularity representation	163
Figure 53 Independent samples test view of modularity representation - understandability task effectiveness (control flow-only)	164
Figure 54 Pairwise comparisons of modularity representation - understandability task effectiveness (control flow-only).....	165
Figure 55 Independent samples test view of modularity representation - perceived ease of understanding.....	167
Figure 56 Pairwise comparisons of modularity representation - perceived ease of understanding.....	168
Figure 57 Independent samples test view of presentation medium - understandability task effectiveness.....	170
Figure 58 Independent samples test view of presentation medium - perceived usefulness for understandability.....	171
Figure 59 Independent samples test view of presentation medium - perceived ease of understanding.....	172
Figure 60 Independent samples test view of intensity of working with process models - understandability task efficiency	175
Figure 61 Pairwise comparisons of intensity of working with process models - understandability task efficiency	176
Figure 62 Independent samples test view of intensity of working with process models - perceived ease of understanding.....	178
Figure 63 Pairwise comparisons of intensity of working with process models - perceived ease of understanding.....	179
Figure 64 Independent samples test view of BP modeling knowledge – understandability task efficiency	183
Figure 65 Pairwise comparisons of BP modeling knowledge - understandability task efficiency.....	184

Figure 66 Independent samples test view of BPMN 2.0 knowledge - understandability task efficiency.....	187
Figure 67 Pairwise comparisons of BPMN 2.0 knowledge - understandability task efficiency.....	188
Figure 68 Independent samples test view of BPMN 2.0 knowledge - perceived ease of understanding.....	189
Figure 69 Pairwise comparisons of BPMN 2.0 knowledge - perceived ease of understanding.....	190
Figure 70 Independent samples test view of theoretical knowledge on BP modeling and BPMN 2.0 - understandability task effectiveness.....	193
Figure 71 Pairwise comparisons of theoretical knowledge on BP modeling and BPMN 2.0 - understandability task effectiveness.....	194
Figure 72 Kruskal-Wallis test results for understandability variables by modularity representation (for each experiment).....	195
Figure 73 Kruskal-Wallis test results for understandability variables by presentation medium (for each experiment).....	195
Figure 74 Kruskal-Wallis test results for understandability variables by experience with process models (for each experiment).....	195
Figure 75 Kruskal-Wallis test results for understandability variables by intensity of working with process models (for each experiment).....	196
Figure 76 Kruskal-Wallis test results for understandability variables by familiarity with process domain (for each experiment).....	196
Figure 77 Kruskal-Wallis test results for understandability variables by BP modeling knowledge (for each experiment).....	196
Figure 78 Kruskal-Wallis test results for understandability variables by BPMN 2.0 knowledge (for each experiment).....	196
Figure 79 Kruskal-Wallis test results for understandability variables by theoretical knowledge on process modeling and BPMN 2.0 (for each experiment).....	197
Figure 80 Kruskal-Wallis test results for understandability variables by modularity representation (for each process model).....	198
Figure 81 Kruskal-Wallis test results for further analysis of understandability task effectiveness by modularity representation (for each process model).....	198
Figure 82 Kruskal-Wallis test results for further analysis of understandability task efficiency by modularity representation (for each process model).....	199
Figure 83 Kruskal-Wallis test results for understandability variables by presentation medium (for each process model).....	199

LIST OF ABBREVIATIONS

ANOVA	Analysis of Variance
BP	Business Process
BPM	Business Process Management
BPMN	Business Process Model and Notation
CAPA	Corrective and Preventive Action
CFC	Control-flow complexity
CH	Complaint Handling
CV	Coefficient of Variation
eEPC	Enhanced Event-driven Process Chain
EPC	Event-driven Process Chain
ER	Entity-relationship
HPN	Health Process Notation
K-S	Kolmogorov-Smirnov
MEME	Multiple-entry-multiple-exit
OMG	Object Management Group
OML	OPEN Modeling Language
OMT	Object Modeling Technique
OPM	Object-Process Methodology
PEU	Perceived Ease of Understanding
PF	Personal Factor
PMF	Process Model Factor
PMUI	Process Model Understandability Indicator
PUU	Perceived Usefulness for Understandability
Q-Q	Quantile-Quantile
RQ	Research Question
RUCM	Restricted Use Case Modeling
R&D	Research and development
SD	Standard Deviation
SEQUAL	Semiotic Quality
SESE	Single-entry-single-exit
SLR	Systematic Literature Review
SPEM	Software Process Engineering Metamodel
S-W	Shapiro-Wilk
TAM	Technology Acceptance Model
UML	Unified Modeling Language
VIF	Variance Inflation Factor
YAWL	Yet Another Workflow Language

CHAPTER 1

1 INTRODUCTION

Goguen and Varela (1979) have emphasized that, “The world does not present itself to us neatly divided into systems, subsystems, environments, and so on. These are divisions which we make ourselves, for various purposes, often subsumed under the general purpose evoked by saying for convenience” (p. 31). Decomposition is a crucial activity that we humans use to understand the world (Devillers, 2011).

Business process models are the core assets of today’s modern organizations. The size and complexity of process models increase steadily as the real-world processes get more complicated. In order to deal with this complexity and increasing size of process models, modularization techniques are commonly used. Modularity consists of different principles for managing complexity (Langlois, 2002). In software engineering discipline, there are various ways and use cases to apply modularity principles but the ways to apply modularity in business process modeling are more restricted. In this study, modularity includes use of techniques that rely on hierarchical decomposition. When modularity is applied by such techniques, a process model is decomposed into fragments called sub-processes in a hierarchical way in a top-down manner. Thereby, modularization in business process models results in relevant process model representations. Even though sub-processes provide many benefits such as easing the reuse of models, concurrent modeling and flexibility in deployment, the business process management community still discusses whether and when to use modularization. Use of modularity in process models does not rely on empirical evidence.

Our main goal is to find out the influence of use of modularity and presentation medium on understanding of process models. Thus, we conducted a family of experiments including one experiment and two replications. In addition to use of modularity and presentation medium, we tested the effect of external variables which emerge from our experimental design. In our experiments, we take into account the imperative process modeling approach. As described in Chapter 3, we follow an experimental research approach to guide our research. Results of our study can be used to develop process modeling guidelines based on empirical findings. Another contribution of our study is to identify the factors affecting process model understandability in the empirical literature. To achieve this purpose, we carried out a systematic literature review.

In particular, the remainder of this chapter is organized as follows. It continues with a discussion on the background of the problem. Then, the problem is described. Afterwards, purpose of study and significance of study are presented. Chapter 1 ends with description of structure of this thesis.

1.1 Background of the Problem

Business process modeling is an essential component of successful business process management. It is a fundamental activity to understand and communicate process information, and often a prerequisite for conducting process analysis, redesign and automation (Dumas, La Rosa, Mendling, & Reijers, 2013). According to the analysis of 289 papers published in BPM conferences between 2000 and 2011, the largest interest has been on process modeling among the phases of business process management (Wil M.P. van der Aalst, 2012a).

Business process models are used for various purposes: increasing understanding of a process among knowledge workers, providing basis for execution and automation of a process, sharing process information with customers, or for what-if analysis (Pinggera, 2014; Recker, Rosemann, Indulska, & Green, 2009). In many application areas of BPM, one of the main purposes of modeling is using process models as a means of communication. In a Delphi study in 2009, three main stakeholder groups (academics, practitioners and vendors of business process modeling tools) have identified process improvement, shared understanding and improved communication as the three most important benefits of process modeling (Indulska, Green, Recker, & Rosemann, 2009). Improved and consistent understanding of processes has been ranked as the second main benefit. According to Curtis, Kellner, and Over (1992), one of the five basic uses of process modeling is facilitating human understanding and communication. If the users of a process model cannot understand the process thoroughly, they would hardly follow it as it is specified. Thus, the business process models should be understandable by people who will perform the tasks in the process and other users of the process from very different disciplines and knowledge levels such as domain experts, department heads and IT experts (Dehnert & van der Aalst, 2004). In brief, in order for process models to successfully serve for their potential uses, they should be perceived as understandable by their audience.

Understandability of process models was stressed out in several studies. A research on the verification of process models shows that there are critical problems with the construction and understandability of process models (Mendling, 2009). Moreover, the same research finds out that many process model collections from practice have error rates of up to 20%. One typical characteristics of unsuccessful process modeling is the lack of qualified modelers in process modeling projects, which causes several quality issues (Rosemann, 2006) that might decrease understandability of process models. On the other hand, knowledge employees from various business units and technical departments are increasingly involved in the modeling of processes (Becker, Rosemann, & Uthmann, 2000). This increasing number and diversity of process model designers is a risk to the quality of process models, hence to their understandability. Process modelers should regard understandability as an important quality attribute to be achieved. As such, process model understandability is considered as one of the most important criteria for process model quality (Guceglioglu, 2006; Moody, Sindre, Brasethvik, & Solvberg, 2002) and has gained considerable attention in academia (Reijers & Mendling, 2011).

Process model understandability (or comprehension) can be defined as the degree to which information contained in a process model can be easily understood by a reader of that model (Reijers & Mendling, 2011). Many researchers argue that understanding process models should be regarded as a learning process where the users of a model integrate model content with their previous experience in order to construct new knowledge as an output of this

learning process (Reijers, Recker, & Wouw, 2010a). Process model understandability is typically associated with the ease of use and the effort required for reading and correctly interpreting a process model (Houy, Fettke, & Loos, 2014). The user of a process model needs to evaluate a large amount of information and make a related selection to find a set of correlated objects, attributes or relationships for a given object or concept (Wang, Wang, Patel, & Patel, 2003). Understanding of the domain information represented in a business process model is necessary for all model-based problem-solving tasks such as communication, systems analysis, design, organizational reengineering and others (Recker et al., 2009). It is mandatory that stakeholders dealing with these tasks are able to understand the process model well and timely (Mendling, Strembeck, & Recker, 2012). Thus, a process model needs to be understandable.

The increasing complexity of real-life processes leads to an increase also in size and complexity of the models that represent them. These two factors are known to impair understandability (Mendling, Reijers, & Cardoso, 2007; Mendling, Reijers, & van der Aalst, 2010; Recker, 2012; Sanchez-Gonzalez, Garcia, Ruiz, & Mendling, 2012; Zugal, Pinggera, Weber, Mendling, & Reijers, 2011). Moreover, the process models with larger size have a higher error rate than small process models (Mendling, Neumann, & van der Aalst, 2007; Mendling, Verbeek, van Dongen, van der Aalst, & Neumann, 2008). If enough detail is not provided in the process model, it is not informative; if the process model is too complex, the user is burdened with the semantics and led to simplify the model (Feltovich, Hoffman, Woods, & Roesler, 2004).

Information hiding is the concept of shielding users from irrelevant information. One commonly used way to ensure information hiding is modularization. Moreover, modularization is regarded as a mechanism to deal with complexity. Modularity, hierarchy and decomposability can be used interchangeably (Reijers, Mendling, & Dijkman, 2011). Essentially, a modular system is not necessarily decomposable as the modules may be designed and implemented separately (Langlois, 2002). In practice, hierarchical decomposition plays a central role for organizing processes in an understandable way and for refining coarse-granular towards a fine-granular representation (Malinova, Leopold, & Mendling, 2013, p. 1209). Hierarchy in business process models allows hiding some model elements in sub-models known as sub-processes. Using sub-processes is a way to decompose a process model, but it also provides a relationship that span different process models. A sub-process indicates that an activity of a process model (parent model) corresponds to another process model (child model). When the activity is called, the relevant sub-process has to be executed.

A number of hierarchical decomposition techniques are proposed in the literature. These include, for instance, a technique using decomposition into a tree of SESE fragments (Vanhatalo, Volzer, & Leymann, 2007), techniques based on decomposition into MEME fragments (which are more general than SESE fragments) (Hauser, Friess, Kuster, & Vanhatalo, 2008; Zerguini, 2004), a technique based on data flow decomposition approach (Adler, 1988), a decomposition model (Wand & Weber, 1989), heuristics for decomposing business process models (Milani, Dumas, Matulevicius, Ahmed, & Kasela, 2015), and an approach exploiting activity labels (Koschmider & Blanchard, 2007). However, none of these techniques has emerged as dominant, probably because each has relative strengths and limitations.

Modularization through the use of sub-processes has widely been considered as a practical means to deal with the size and complexity of models (Parnas, 1972; Reijers & Mendling, 2008; Zugal et al., 2013) as sub-processes reduce the size and complexity of top-level process model by abstracting the details. Modularization in business process models that is achieved by means of sub-processes are considered to have many advantages:

- Maintainability is increased through sub-processes. A sub-process can be updated without modifying the high-level process model.
- Sub-processes foster reuse of process models. When there are common parts in different business process models, these parts can be modeled as a sub-process (Koschmider & Blanchard, 2007; Leymann & Roller, 1997; W. van der Aalst & van Hee, 2002).
- Sub-processes provide concurrent development possibility and accelerate total modeling time (Leymann & Roller, 1997; W. van der Aalst & van Hee, 2002).
- During execution of a process model, sub-processes enable scalability as each sub-process can be deployed to a different workflow server or BPM engine (Leymann & Roller, 1997).

Using sub-processes to represent complex process models is considered also to contribute to the understandability of these models (Dong & Chen, 2005; Koschmider & Blanchard, 2007; Sharp & McDermott, 2008). Commonly, researchers expected to provide empirical evidence for the positive effects of use of modularity in process models. However, empirical research on the influence of modularization on the understandability of business process has shown mixed results. Some works report a negative influence on understanding (Cruz-Lemus, Genero, Piattini, & Toval, 2005), no influence (Cruz-Lemus, Genero, Manso, Morasca, & Piattini, 2009; Cruz-Lemus et al., 2005; Zugal et al., 2013) or a positive influence (Cruz-Lemus et al., 2009; Reijers et al., 2011).

Few works in the literature describe the influence of modularization on the understandability through the concept of mental effort. Mental effort corresponds to mental resources required to solve a problem (Sweller, 1988). Hiding less relevant information in sub-models is expected to decrease the mental effort (cognitive load) needed to understand the model (Moody, 2004), whereas fragmentation due to modularization increases the mental effort by forcing the reader to switch attention between different fragments (so called the split attention effect (Zugal et al., 2013)).

Many process modeling languages allow for the design of hierarchical structures. Modularization is available through composite states in UML Statechart Diagrams (Object Management Group, 2015), assigning another EPC model to a function in EPC (Scheer, 2002) and sub-processes in BPMN (Object Management Group, 2014) and YAWL (W.M.P. van der Aalst & ter Hofstede, 2005).

1.2 Statement of the Problem

Three critical problems related with the modularity of business process models are identified in the literature.

- Zugal et al. (2011) analyze prior empirical investigations on the effect of hierarchy on process model understandability and conclude that it is still unclear under which circumstances positive or negative influence on understandability can be expected.

- The discussions about the proper way of using modularity and its implications on the understandability of models are not conclusive (Figl, Koschmider, & Kriglstein, 2013; Reijers et al., 2011; Zugal et al., 2013).
- There are no explicit guidance and objective criteria for using decomposition in business process models that modelers can rely on (Reijers & Mendling, 2008). There is a lack of theoretically grounded guidelines and approaches for modularizing process models into sub-processes (Reijers et al., 2011).

Though there is a common belief that hierarchy has a positive effect on process model understandability (Zugal et al., 2011), the empirical literature shows that use of hierarchy has a positive effect (Cruz-Lemus et al., 2009; Reijers et al., 2011), negative effect (Cruz-Lemus et al., 2005) or no effect (Zugal et al., 2013) on understandability. As the influence of hierarchy on process model understandability differs from negative over neutral to positive, it is still unclear whether hierarchy is useful to enhance understanding.

Though progress could be achieved in research on the use of modularity in business process models, for instance, by adopting a decomposition model (Wand & Weber, 1989) for modularizing EPCs (Johannsen & Leist, 2012) and BPMN models (Johannsen, Leist, & Tausch, 2014), developing heuristics for decomposing business process models (Milani et al., 2015) and the application of abstraction levels in business process models (Smirnov, Reijers, & Weske, 2012), a discussion about the proper use of modularity continues.

There are some recommendations on when a process model needs to be split up into sub-processes. Kock Jr and McQueen (1996) suggest that each process model should not have more than 5 to 15 activities so that the model can easily be understood where Sharp and Mcdermott (2008) state that modularization should be introduced in a process model having more than 5 to 7 activities. Decomposing a process model with more than 31 nodes (activities) is proposed by Mendling, Sanchez-Gonzalez, Garcia, and La Rosa (2012). Seven process modeling guidelines (Mendling, Reijers, & van der Aalst, 2010) depicts that if a process model has more than 50 elements, it should be split-up into sub-processes. In this sense, it is important to note that the number of activities can vary in a process model consisting of 50 elements, depending on the process modeling language. For instance, EPCs use connectors and BPMN uses gateways for decision points whereas YAWL uses only tasks. Still, decomposition in business process models is generally applied in an ad-hoc manner. Business process management (BPM) community has recognized modularization as a factor effecting process model understandability (Damij, 2007) but generally accepted guidelines on decomposing business process models are missing.

As process modeling is at the core of process-centered management (Indulska et al., 2009), a wide range of process modeling languages such as UML Activity Diagram (Object Management Group, 2015), EPC (Scheer, 2002) and BPMN (Object Management Group, 2014) has been available to assist practitioners for modeling business processes (Malinova & Mendling, 2015; Recker, 2011). Among them, existing empirical research analyzing the influence of use of modularity on process model understandability used UML statechart diagrams, Workflow Nets (W.M.P. van der Aalst, 1997) and DecSerFlow (W.M.P. van der Aalst & Pesic, 2006) which is a declarative process modeling language, as modeling grammars to model the objects used in experiments. Chinosi and Trombetta (2012) have emphasized the capabilities and strengths of BPMN compared to other process modeling languages. What is important for us is that the primary goal of BPMN is to provide a notation that is understandable by human, it is not execution of models (Mili et al., 2010).

Though BPMN is such a substantial modeling language for creating understandable process models, the influence of use of modularity in BPMN v2.0 (e.g. sub-processes, groups) on the understandability of process models has not been investigated.

Another factor that has not been addressed in the literature is the medium used to present the models to their audience. Although the paper is usually the preferred means for interacting with model readers in practice (Reijers & Mendling, 2008), the models are typically designed using software applications (particularly when the objective is process automation), and communicated through an online environment (e.g. web portal, company intranet) across the organization and beyond. Therefore, it is important to explore if using paper or a computer environment has any effect on model understandability.

In recent years, experimental research has gained attention as a research method in business process management discipline (Recker, 2014). Experimental research addresses a limited set of properties of a phenomenon (e.g. a property of a model) and examines these properties in controlled settings. Throughout this research, we will examine understandability property of business process models. Since evidence gathered through a set of experiments will be used to test whether certain variables affect other variables such as understandability in some way or not, we decided to follow experimental research guided by the framework for experimental software engineering of Wohlin et al. (2012).

1.3 Research Strategy

The objective of this study is *to investigate the influence of using different forms of modularity and presentation medium on the understandability of processes modeled in BPMN*. As a first step in our study, we conducted a systematic literature review with the aim to investigate an exhaustive list of factors influencing process model understandability as analyzed and reported in the related literature. In particular, our systematic literature review aimed at answering the following research questions:

- How is the understandability of business process models operationalized in the literature?
- What factors that are considered to influence the understandability of business process models have been investigated in the literature?

To meet our objective, we designed and conducted three experiments with the participation of 60 practitioners working in a large organization in Netherlands, 55 participants working in a national research institute in Turkey and 140 students from a university in Netherlands. For the experiments, we used models of two business processes, which are being conducted in the organization in Netherlands. Process models are of similar size and structure, and can be considered large in scale. Empirical results obtained in our study can be used to develop specific guidelines for business process modeling.

In the process of investigating the influence of modularity representation and presentation medium, we also test the effects of a set of external variables, which emerge from our experimental design, on the understandability of process models. In order to examine the effect of both modularity representation, presentation medium, and the external variables, hypotheses were developed, a series of experiments were conducted, and statistical analyses were performed on the results. The findings offer a significant move towards comprehending what contributes to an understandable process model.

The development of business process models which describe how an organization performs its business is a fundamental prerequisite for organizations to engage in business process management initiatives (Indulska et al., 2009). Such models are foremost required to be understandable as in other forms of conceptual modeling (Mendling, Reijers, & Recker, 2010). Our study will be a significant endeavor in examining the influence of the use of modularity and presentation medium on the understandability of BPMN process models. BPMN has gained significant attention and broad acceptance by users in recent years (Chinosi & Trombetta, 2012), and it is currently the most widely used process modeling language in practice (Harmon & Wolf, 2014). The wide use of BPMN makes the research on the understandability of such models critically important.

Our research presents empirical findings that contribute to the existing body of knowledge, particularly, in developing process modeling guidelines. Process modelers will benefit from the results of our study, specifically in applying modularity when using BPMN.

Our systematic literature review of empirical works offers an additional contribution to the field in terms of an extensive list of factors considered to influence process model understandability. This model will also serve as a future reference for researchers working on the understandability of business process models and for practitioners who aim to generate an understandable process models.

1.4 Structure of the Thesis

The remainder of this thesis is organized as follows. Chapter 2 presents the results of our systematic literature review. It discusses the related work on the factors (including the modularity) that are considered to affect process model understandability, and the metrics/indicators used to operationalize process model understandability as investigated by the empirical works. We dedicated Chapter 3 for the methodology that we followed for this empirical study. It presents the research design including the research model that we tested, and the setup of the experiments. Chapter 4 provides the results of the statistical analyses. It also discusses the results in comparison with the findings in the existing literature. Finally, Chapter 5 presents our conclusions and summarizes the contributions of this research, including its implications for the academy and practice. It also discusses the limitations and recommendations for future research directions.

CHAPTER 2

2 LITERATURE REVIEW

As process models can be seen as conceptual models, research on conceptual modeling quality has been related to business process modeling quality. Understandability has been established as one of the most important quality criteria of conceptual models (Houy, Fettke, & Loos, 2012) and it had been discussed in conceptual modeling quality frameworks. Conceptualizing model understandability has resulted in useful findings in the area of data modeling with ER diagrams (Masri, Parker, & Gemino, 2008) and object modeling with UML analysis diagrams (Burton-Jones & Meso, 2006).

We first looked into the understandability view of conceptual modeling quality frameworks. A semiotic framework called the SEQUAL Framework for evaluating the quality of conceptual models was originally proposed by Lindland, Sindre, and Solvberg (1994). Proposed framework has three dimensions; syntactic quality, semantic quality and pragmatic quality. The pragmatic quality has only one goal: comprehension. The ultimate goal was stated as to ensure the model has been understood not to declare that the model can be understood. An empirical analysis of SEQUAL Framework was conducted and as a result, the framework was found to be easy to use and useful in evaluating process models and participants intended to use it (Moody et al., 2002). SEQUAL framework was later revised in Krogstie, Sindre, and Jorgensen (2006) for the particular needs of process models by adding new dimensions of quality such as social quality and organizational quality. Moody (2005) stressed out that developing a common quality framework for conceptual modeling should be a priority for researchers and practitioners. Conceptual Modeling Quality Framework (CMQF) integrated the SEQUAL (Lindland et al., 1994) and a framework developed by Wand and Weber based on Bunge's ontological theory (BWW) (Wand & Weber, 1990) and benefited from two different perspectives of these frameworks (Nelson, Poels, Genero, & Piattini, 2012). Pragmatic Quality in the learning quality layer addresses the understandability of the final model by users in this framework.

Understandability had been discussed not only in conceptual modeling quality frameworks but also in studies that focus on the quality of business process models. Understandability was considered as one of the process model quality attributes in Guceglioglu (2006) and it was adapted from "function understandability" metric of ISO/IEC 9126 Software Product Quality Model. SIQ framework was introduced in Reijers, Mendling, and Recker (2010) and has three categories of process model quality namely semantic quality, pragmatic quality and syntactic quality. Pragmatic quality relates to whether a process model can be understood by people. A process model can have a low semantic quality but the same model can be perfectly understood, which indicates a high pragmatic quality. 3QM-Framework was proposed by Overhage, Birkmeier, and Schlauderer (2012) to assess process model quality. This framework presents two metrics for the assessment of process model understandability,

non-normalized labels and inconsistent labels. First one measures the number of violations of labeling conventions where the latter one measures how often carriers of meaning are labeled inconsistently in a process model.

Though there exist workflow and process modeling initiatives over the past 30 years, Mendling and Strembeck (2008) explain that we know little about the act of modeling and about the factors contributing to a good or high quality process model in terms of human comprehension. In the literature, process modeling guidelines have been proposed to guide process modelers for high model quality, including the Guidelines of Modeling (Schuette & Rothowe, 1998), Guidelines of Business Process Modeling (Becker et al., 2000), Seven Process Modeling Guidelines (7PMG) (Mendling, Reijers, & van der Aalst, 2010), and the Modeling Guidelines for Business Process Models (Schrepfer, 2010). Generally accepted and empirically validated guidelines for producing understandable process models and means for measuring the understandability level of process models are missing.

A collection of patterns to improve understandability of process models have been proposed (La Rosa, ter Hofstede, et al., 2011; La Rosa, Wohed, et al., 2011). Patterns for concrete syntax modifications defined in La Rosa et al. (2011) include mechanisms for arranging the layout, for highlighting the parts of the model using enclosure, graphics or annotations, for representing specific concepts explicitly and for providing naming conventions for model elements' labels where patterns for abstract syntax modifications defined in La Rosa et al. (2011) include the usage of modularization, composition, duplication, compacting, merging and block-structuring, restriction and extension techniques and thus affect the formal structure of process model elements and their relationships.

A systematic literature review to find out quality guidelines for business process modeling was conducted (de Oca, Snoeck, Reijers, & Rodriguez-Morffi, 2015) and further research to develop a more comprehensive quality framework was suggested based on the interpretation of results. Another systematic literature review was performed on business process measurement (Gonzalez, Rubio, Gonzalez, & Velthuis, 2010). Understandability was found to be the second most measurable concept (by 21%) used by authors in their articles. However, majority of measures do not follow a standard and only a small percentage of proposed measures have been empirically validated. To evaluate how conceptual model understandability was measured, a reference framework was presented by Houy et al. (2012) covering different dimensions of model understandability as a result of a systematic literature review. Six dimensions including objective and subjective dimensions as well as effectiveness and efficiency dimensions were identified. Most used dimension was found to be 'correctly answering questions about the model content' (No.2) as it was utilized in 39 of 42 articles. This research showed that the most frequently used method for measuring understandability had been to ask questions that aim to test the understandability of conceptual models. It was concluded that there was no consensus about understanding of model understandability. Houy et al. (2014) conducted a systematic literature analysis on underlying theories of research into business process model understandability by means of an analysis of 126 articles and reported on trends in theory usage. The results showed that 80 of 126 articles use or refer to theories and there is no dominating or commonly used theory as the foundation of business process model understandability research.

There are empirical studies which examined one or more than one factor that might have an impact on the understandability of business process models but a study which presents a view of all the factors examined and their impacts does not exist, so far. We systematically

assessed the state of the art by conducting a systematic literature review in order to identify factors that are considered to influence the understandability of business process models as investigated in related literature. Our review provides a complete view of an extensive list of factors that has been empirically investigated in the literature. We focused only on empirical studies during this systematic review. As research questions direct the design of a systematic literature review process, defining them is a significant part of any systematic review (Kitchenham & Charters, 2007). The research questions that we formulated for this research are given below:

***RQ1.** How is the understandability of business process models operationalized in the literature?*

Understandability can be measured in several ways using various indicators. Answering our first research question will give insight into this diversity.

***RQ2.** What factors that are considered to influence the understandability of business process models have been investigated in the literature?*

The objective in the second research question is to identify all factors that were investigated by researchers in empirical studies. Answering this question relies on the results and findings of studies that empirically test the effect of a factor or factors on business process model understandability. Determining these factors will give an insight to which factors get the most and least interests from the business process management community. Answer of RQ2 will also provide the current body of knowledge. By this knowledge, process modelers can have opinion on how to result in an understandable process model.

We discuss the methodology that we followed during the systematic literature review in the first section. Afterwards, we summarize the findings. In the third and fourth parts, we present the summary of empirical evidence we obtained from primary studies to answer our research questions. Finally, we present our conclusions and discuss opportunities for future research in the last part.

2.1 Systematic Literature Review Design

This systematic literature review was carried out following the guidelines provided by Kitchenham and Charters (2007) and Webster and Watson (2002). The literature search was performed for the studies published in academic journals and conference proceedings between the years 1995 and 2015 (February), as made available through the electronic libraries of (in search order); Scopus, ScienceDirect, ACM, Web of Science, IEEE Xplore and Springer Link. While performing systematic literature review, Microsoft Excel was used heavily by the author to store publication information, calculate numerical results, prepare related charts and communicate with other researchers. The following steps in Figure 1 were derived from the guidelines for performing systematic literature reviews in software engineering (Kitchenham & Charters, 2007) and applied as a procedure in systematically searching and selecting relevant studies.

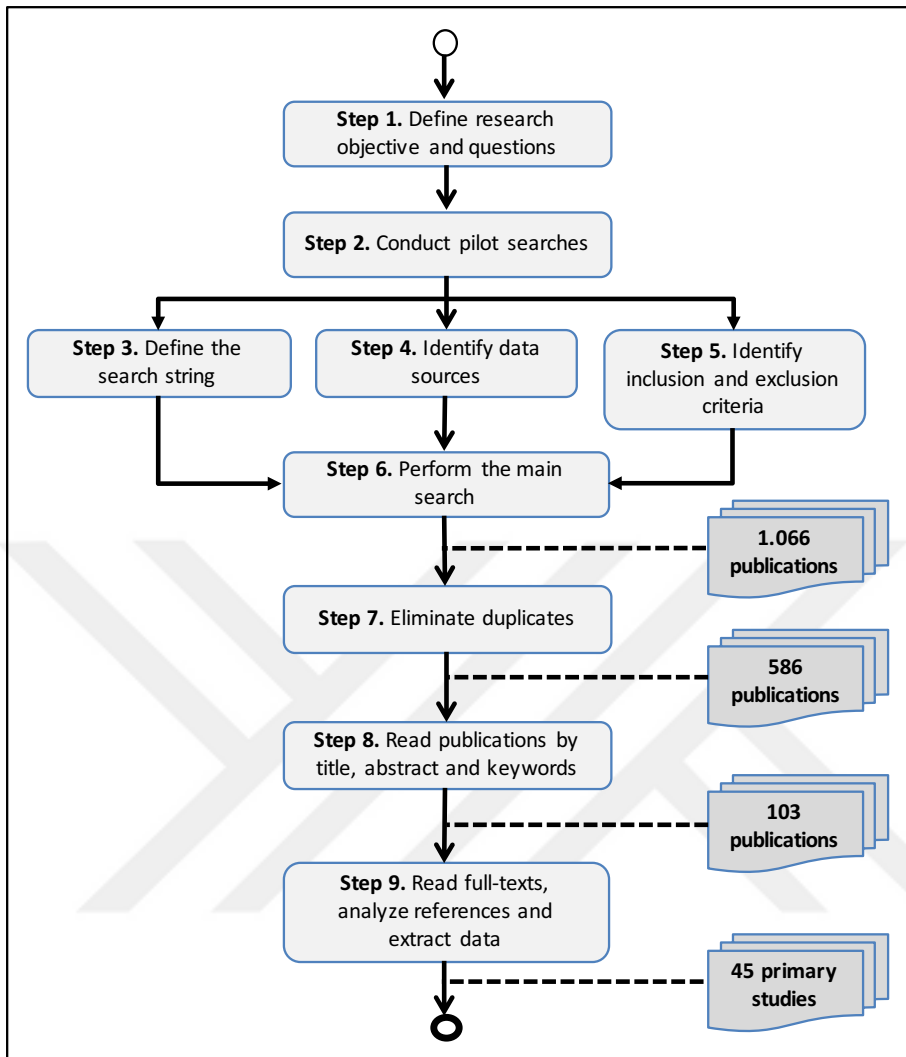

Figure 1 SLR steps and resulting number of publications

Step 1. Define research objective and questions: We started the systematic literature review with defining the research objective and questions as presented above.

Step 2. Conduct pilot searches: This step was conducted to review the scope, try different searches, and see the differing results to refine the search string to be used for the subsequent comprehensive searches.

Step 3. Define the search string: The search string, which was formed according to our research questions, comprises relevant keywords as refined in the example searches and preliminary literature review in Step 2. For the retrieval in the data sources (electronic libraries), the search string given below was derived and taken as a basis.

((understandability OR comprehension) AND ("process model" OR UML))

Step 4. Identify data sources: In order to find out relevant studies, we searched the following six major electronic libraries: (1) Scopus, (2) ScienceDirect, (3) ACM Digital

Library, (4) Web of Science, (5) IEEE Xplore, (6) SpringerLink. URLs of electronic libraries are given in order: (1) <http://www.scopus.com>, (2) <http://www.sciencedirect.com>, (3) <http://dl.acm.org>, (4) <http://apps.webofknowledge.com>, (5) <http://ieeexplore.ieee.org>, (6) <http://link.springer.com>

Step 5. Identify inclusion and exclusion criteria: Inclusion and exclusion criteria to be applied were determined in this step. The following lists provide these criteria:

Inclusion Criteria:

1. Publications published in English language
2. Publications that are published between 1995 and 2015
4. Publications that present *empirical* studies
5. Publications that use quantitative (e.g., statistical) analysis methods for data analysis
6. Publications that focus on the factors that are considered to influence the understandability of ‘business process models’ (modeled using BP modeling notations, such as BPMN, EPC) and of models that are depicted as UML behavioral diagrams. Behavioral UML diagrams illustrate the behavior of a system and show very similar characteristics as process models. They are also commonly used for modeling processes (Glezer, Last, Nachmany, & Shoval, 2005). These types of diagrams include (Object Management Group, 2015):
 - UML Activity Diagram
 - UML Interaction Diagrams (Sequence Diagram, Communication Diagram, Interaction Overview Diagram, Timing Diagram)
 - UML Use Case Diagram
 - UML State Machine Diagram

By including the studies that investigate factors on the understandability of such models, we aimed at enriching the findings and strengthen our conclusions derived from the literature.

Exclusion Criteria:

1. Publications in the grey literature; i.e. papers without bibliographic information (such as publication date/type, volume and issue numbers), working papers, or white papers
2. Publications that investigate conceptual models that are not in the form of business process/behavioral models (UML class diagrams, Entity-Relationships diagrams, etc.)
3. Publications which have enhanced, more complete and recent versions that offer a larger extent of contribution than the original paper.

Step 6. Perform the main search: As each electronic library provides slightly different searching features, specific query strings and strategy was developed for each library taking the search string formulated in Step 3 as the basis. As a general rule, the query strings were applied to the title, keywords, and abstracts of the publications residing in the libraries. (This is with the exception of Springer Link, which supports searching only full-texts and titles. Our search in this library resulted 4.993 publications, which were sorted by relevance. The first 167 publications were considered relevant, as further examination of publications between 167 and 250 did not identify any additional relevant work.) In total, 1,066 publications were initially retrieved.

Step 7. Eliminate duplicates: Before applying the inclusion and exclusion criteria, duplicate entries resulting from the search of multiple databases were removed to generate a list of unique publications. After a careful review of 1,066 publications, 480 were marked as duplicate, leading to 586 (unique) publications.

Step 8. Read publications by title, abstract and keywords: Each publication was reviewed based on the information provided in the title, abstract and keywords. Inclusion and exclusion criteria (except the 3rd exclusion criterion) were applied in this step for selecting relevant publications. As a result, 103 (out of 586) publications were identified for thorough investigation.

Step 9. Read full-texts, analyze references and extract data: We read full-texts of 103 publications. Re-applying the inclusion and exclusion criteria to these publications led to a refined list of 40 publications. We also analyzed the references of these publications and identified 5 additional studies that were missing in our initial master list. The step led to a final list of 45 primary studies. Accepting a publication as a primary study meant that it would be used as a source to be used to answer the research questions of our systematic literature review.

2.2 Structure of the Extracted Research Data

For the thorough investigation, a data extraction form was constructed that defines the key data items to be collected for each publication. This involves information about the research method and design -including the investigated understandability factors and indicators used to measure model understandability, experimental setup, analysis method, and key findings.

For each understandability factor that has been investigated in a study, we analyzed the *type* of the effect (direct, moderation, or both) and its *direction* (positive, negative, existence) on the process model understandability indicators.

Type of the effect of the factor (direct / moderation): The effect of an understandability factor is considered to be *direct* when the change in the factor results a proportional change in the indicator used to measure understandability. In the *moderation* effect, the factor influences the direction and/or strength of the relation between another (direct) factor and the understandability indicator. A study can investigate a factor as a direct or moderator factor or both.

Direction of influence of the factor: Direction of the effect can be investigated depending on the effect type. For a *direct* factor, the following directions (of influence on a process model understandability indicator) can be observed:

- No effect
- Positive effect
- Negative effect
- Existence effect

A *direct* factor is considered to have ‘no effect’ if the analysis shows no statistically significant influence of the factor on a process model understandability indicator. The direction of a statistically significant influence can be of positive, negative or existence type.

For direct factors with ordinal scales, the direction of influence is of *existence* type (e.g. use of paper or computer as a representation medium). The positive effect indicates a positive relation between the factor and the understandability indicator (i.e., an increase in the direct factor leads to an increase in the understandability). The negative effect indicates an opposite direction.

For the *moderator* factor, we categorized the direction of the influence either as *no-effect* or *significant* effect. A significant effect for a moderator factor indicates that the factor has an influence on the relation between a direct factor and the understandability indicator.

2.3 General Findings

Figure 2 shows the distribution of primary studies by year (from 1995 to 2015). Number of publications has reached the highest number (12) at 2013. We observe that there is a general trend for increasing number of publications in the recent years. Performing searches in electronic libraries between 2015 February and 2015 May (heavily in the first quarter of 2015) might have resulted in not finding a study published in 2015.

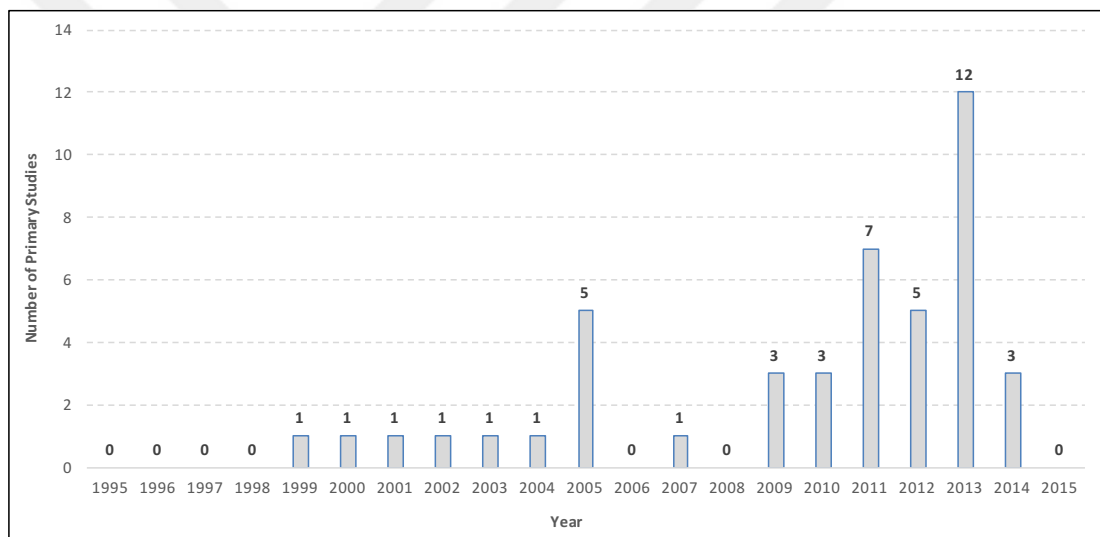

Figure 2 Distribution of primary studies by year

Out of 45 primary studies, 24 are published in journals, 15 in conference proceedings, and 6 as workshop papers. Figure 3 presents the distribution of primary studies by publication type. (We should also note that due to our 3rd exclusion criterion, 19 conference/workshop publications were taken out of the primary list, as these have recent versions with enhanced contributions that are typically published as journal publications). The results about the numbers and types indicate that the business process model understandability is a mature field and it is worth performing a systematic literature review on this topic.

Four publications appeared in the Information and Software Technology journal, which corresponds to the highest number among the journals. The numbers for the conference publications indicate an even spread over the conferences. Only two conferences have two publications each (CAiSE - International Conference on Advanced Information Systems Engineering, and VL/HCC - IEEE Symposium on Visual Languages and Human-Centric Computing).

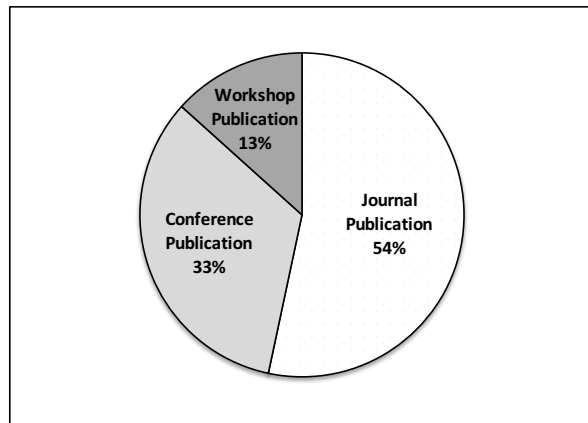

Figure 3 Distribution of primary studies by publication type

Figure 4 shows the number of experiment participants used in each empirical study, including the ratio of students to industry practitioners. Accordingly, a large majority of the subjects (88%) that participated in the experiments were students (bachelor, master or PhD), whereas only 12% were industry professionals. The data for the empirical analysis originates from the participation of around 85 subjects on the average for each work.

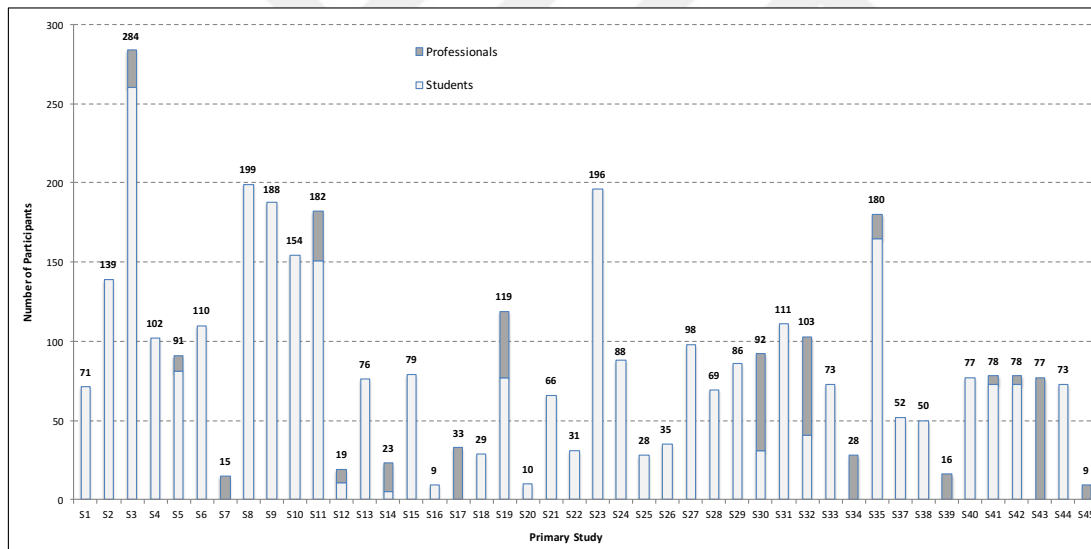

Figure 4 Number of participants in experiments and distribution of participants (the number of experiment participants is not provided in [S36])

The list of process modeling notations used for the experiments, the primary studies that use the notation and the number of primary studies that used the related notation are given in Table 1. In the literature, 20 different notations were used in 41 primary studies that explicitly indicated the type of the process modeling notation that has been used. Some studies used more than one modeling notation, particularly for comparative analysis. BPMN and EPC are the mostly commonly used notations in the empirical works in the process model understandability research (Note that the studies listed in Table 1 that use these languages do not necessarily investigate their influence on the understandability, for instance

by comparisons between languages. Some of these works use a single notation for a process model to investigate the effect of other factors.)

Table 1 Process modeling notations used in primary studies

No	Process Modeling Notation	Number of Primary Studies	Primary Studies
1	BPMN	15	[S6], [S8], [S9], [S10], [S20], [S23], [S25], [S27], [S28], [S29], [S35], [S36], [S37], [S39], [S43]
2	EPC	11	[S8], [S9], [S10], [S14], [S18], [S19], [S28], [S29], [S33], [S38], [S43]
3	UML Statechart Diagram	8	[S3], [S4], [S5], [S12], [S21], [S22], [S41], [S42]
4	UML Activity Diagram	7	[S8], [S9], [S10], [S14], [S31], [S40], [S43]
5	UML Sequence Diagram	6	[S1], [S13], [S21], [S22], [S41], [S42]
6	UML Use Case Diagram	4	[S2], [S15], [S23], [S40]
7	UML Collaboration Diagram	4	[S13], [S21], [S22], [S26]
8	Petri Net / Workflow Net	3	[S32], [S34], [S38]
9	Declare	3	[S16], [S25], [S45]
10	YAWL	2	[S9], [S10]
11	Health Process Notation (HPN)	1	[S39]
12	Tropos	1	[S15]
13	Restricted Use Case Modeling	1	[S44]
14	Textual Representation	1	[S16]
15	SBD (Storyboard)	1	[S43]
16	SPEM	1	[S11]
17	Data Flow Diagram	1	[S1]
18	OML-Internal Collaboration	1	[S21]
19	OML-State Transition	1	[S21]
20	OML-White Box Sequence	1	[S21]

In the subsequent section, we present the indicators that the works we analyzed in our literature review used to operationalize process model understandability. Next, we provide a detailed view on the factors that have been investigated by these works. The complete list of primary studies is given at Appendix A.

2.4 Process Model Understandability Indicators in the Literature

In conceptual modeling domain, understandability of a model is typically measured in terms of *effectiveness* and *efficiency* (Burton-Jones, Wand, & Weber, 2009; Gemino & Wand, 2004). Our study also found these as the most commonly used indicators in the process

model understandability research field. In addition, our study identified further indicators that are used for quantifying process model understandability. Table 2 presents these indicators including the studies that used them.

Table 2 Process model understandability indicators and related primary studies

No	Process Model Understandability Indicator	Number of Primary Studies	Primary Studies
PMUI 1	Understandability Task Effectiveness	38	[S1], [S2], [S3], [S4], [S6], [S8], [S9], [S10], [S13], [S14], [S15], [S17], [S19], [S20], [S21], [S22], [S23], [S24], [S25], [S26], [S27], [S28], [S29], [S30], [S31], [S32], [S33], [S34], [S35], [S36], [S38], [S39], [S40], [S41], [S42], [S43], [S44], [S45]
PMUI 2	Understandability Task Efficiency	25	[S4], [S5], [S9], [S10], [S11], [S12], [S13], [S15], [S16], [S19], [S21], [S22], [S25], [S26], [S27], [S28], [S29], [S31], [S32], [S35], [S36], [S37], [S39], [S40] [S41]
PMUI 3	Cognitive Load (Mental Effort)	3	[S8], [S16], [S45]
PMUI 4	Perceived Ease of Use	10	[S7], [S9], [S10], [S13], [S17], [S18], [S20], [S28], [S38], [S39]
PMUI 5	Perceived Usefulness	5	[S2], [S7], [S17], [S20], [S39]
PMUI 6	Intention to Use	7	[S7], [S17], [S20], [S26], [S38], [S40], [S41]

A brief description of each process model understandability indicator is given below.

PMUI 1. Understandability Task Effectiveness

Subjects are usually confronted with understandability tasks / questions about a process model. Understandability task effectiveness is computed as the number of correct answers divided by the total number of questions in an understandability test. It is the most widely used indicator to evaluate understanding of a process model.

PMUI 2. Understandability Task Efficiency

Understandability task efficiency is operationalized by dividing the number of correct answers by the time it takes to complete understandability questions in most of the primary studies that use this indicator. In a few studies [S11], [S12], [S13] it is operationalized by only the time taken to complete understandability test(s). Its main difference from Understandability Task Effectiveness is considering time.

PMUI 3. Cognitive Load (Mental Effort)

Cognitive Load Theory argues that if the number of process model elements that need to be attended increases, understanding of process model becomes more difficult. According to

Cognitive Load Theory, the capacity of the working memory at a given point of time is limited (Kirschner, 2002). When the amount of information to be processed exceeds this capacity, understandability is affected negatively. In other words, cognitive load should be as low as possible for higher understandability. Zugal, Pinggera, Reijers, Reichert, and Weber (2012) proposed using mental effort in addition to understandability task effectiveness and understandability task efficiency to provide further insight. It corresponds to the mental resources required to solve a problem and was assessed by the user's rating as a subjective measure (perceived difficulty). In [S45], the subjects were asked to assess mental effort (cognitive load) expended in a 7-point rating scale after answering an understandability question [S45]. Cognitive load was considered as an indicator to operationalize the level of understanding in three primary studies [S8], [S16], [S45] and it is the least used indicator to operationalize process model understandability among six indicators.

The other three factors can be grouped in 'User Acceptance' group. Three primary constructs of the framework of TAM (Technology Acceptance Model) by Davis (1989) were used to measure process model understandability in some primary studies. TAM mainly describes how users accept and use a technology.

PMUI 4. Perceived Ease of Use

Perceived Ease of Use can be understood as "the degree to which a person believes that using a particular system would be free of effort" (Moody, 2003). It was measured by the ratings of participants.

PMUI 5. Perceived Usefulness

Moody (2003) defines perceived usefulness as "a person's subjective probability that using a particular system would enhance his or her job performance".

PMUI 6. Intention to Use

Intention to Use was defined as "the extent to which a person intends to use a particular system" (Moody, 2003). Subjects were asked whether they had an intention to use the proposed system or technology.

2.5 Factors Investigated in Primary Studies

The understandability of process models does not depend only on factors intrinsic to the model but also on the properties of the user of the model (Reijers, Recker, & Wouw, 2010b). Hence, we can categorize the process model understandability factors that are studied in the literature into two main groups: process model factors and personal factors. Figure 5 presents these factors including the indicators used to quantify process model understandability (as discussed in Section 2.4). Accordingly, any empirical research that we analyzed in this study investigates the influence of at least one of these factors on at least one of the process model understandability indicator.

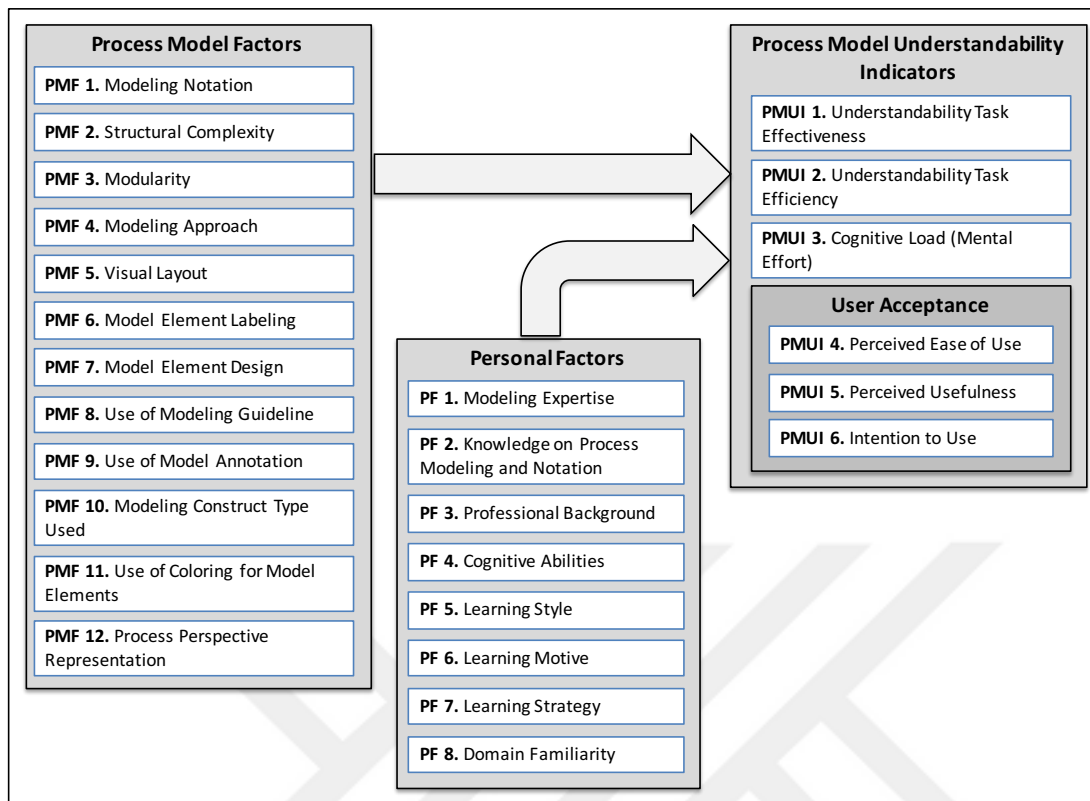

Figure 5 Process model understandability reference model

In total, 20 factors (12 process model factors and 8 personal factors) were investigated in 45 primary studies. These factors with the number of primary studies in which that factor was investigated as a direct factor are presented in Figure 6. The figure shows that, excluding the factor PF 8. Domain Familiarity, all investigated factors are found to influence process model understandability significantly (as there exists at least one primary study where a significant impact of that factor on at least one of the process model understandability indicators exists). There is a single study (S18) that studied the moderation effect of the factor of domain familiarity (PF8), where the effect was found insignificant.

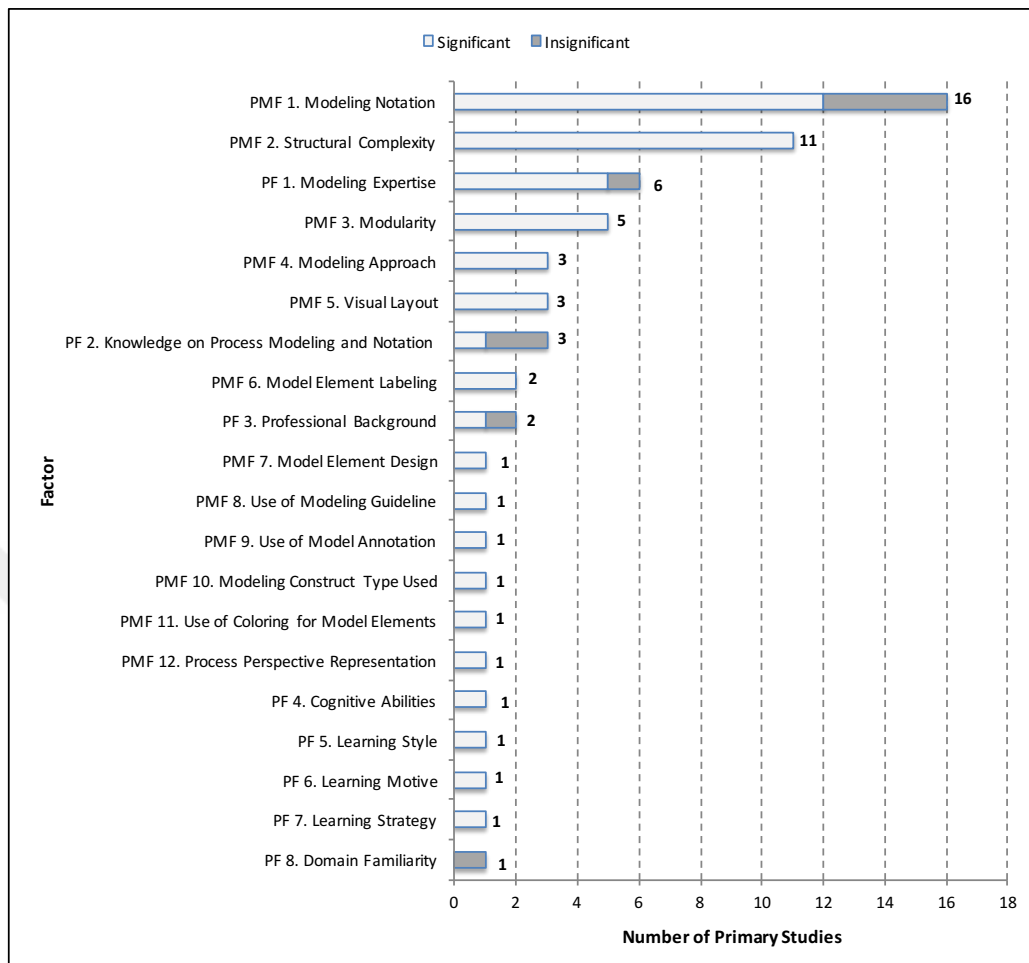

Figure 6 Factors and number of studies that investigate those factors

Table 3 presents the factors that were investigated in each study, including the type of the effect (direct, moderator or both) and whether the effect was found significant or not. The table uses the following convention to indicate this information:

- The sign '✓' denotes that the factor is a direct factor and has a significant effect on at least one of the process model understandability indicators.
- The sign '○' denotes a direct factor that does not have a significant effect on any process model understandability indicator.
- The sign '*' denotes that the factor is investigated as a moderator factor.
- The sign '+' denotes that the factor is investigated both as a direct and moderator factor.

Table 3 Factors investigated in primary studies

Understandability Factor Investigated	Process Model Factors												Personal Factors								
	PMF 1 Modeling Notatic	PMF 2 Structural Complexi	PMF 3 Modularit	PMF 4 Modeling Approac	PMF 5 Visual Layout	PMF 6 Model Element Labeli	PMF 7 Model Element Desiğ	PMF 8 Use of Modeling Guideli	PMF 9 Use of Model Annotatic	PMF 10 Modeling Construct Type Us	PMF 11 Use of Coloring for Model Eleme	PMF 12 Process Perspective Representat	PF 1 Modeling Experti:	PF 2 Knowledge on Process Modeling and Nota	PF 3 Professional Backgrou	PF 4 Cognitive Abiliti	PF 5 Learning Styl	PF 6 Learning Motiv	PF 7 Learning Strateg	PF 8 Domain Familiari	
Primary Study																					
S1				✓																	
S2								✓													
S3			✓																		
S4			✓																		
S5		✓																			
S6		✓																			
S7			✓																		
S8		✓																			
S9	✓																				
S10							✓														
S11		✓																			
S12		✓																			
S13	○																				
S14	○																				
S15	✓																				
S16	✓																				
S17											✓										
S18						✓								○*						○*	
S19						✓							✓	✓							
S20								✓													
S21	✓																				
S22	✓																				
S23	✓																				
S24					✓																
S25				✓																	
S26	✓																				
S27		✓*							✓												
S28	○																				
S29	○												✓								
S30															✓	✓	✓	✓			
S31	✓												✓								
S32										✓											
S33		✓											○	○	✓						
S34			✓																		
S35		✓																			
S36		✓																			
S37		✓																			
S38	✓																				
S39	✓														○						
S40					✓																
S41					✓								✓								
S42		✓*			✓								✓*								
S43	✓																				
S44	✓																				
S45			✓																		

Next, we elaborate on each understandability factor as studied in the literature.

2.5.1 Process Model Factors

Reijers and Mendling (2011) argue that process model features are potentially relevant factors of process model understandability.

PMF 1. Modeling Notation

As we presented in Table 1, several process modeling notations were used in the studies that investigated the influence of various factors on process model understandability. However, only 16 of them examined the process modeling notation as an influential factor. A typical research design for these studies involved a comparative analysis between different modeling notations to investigate if a particular model outperforms the others with respect to model understandability. In 12 studies, using different notations resulted significantly different levels of understandability, which suggests that the process modeling notation can be an influential understandability factor. However, there are also conflicting results even in the experiments that use the same set of process modeling notations. In the paragraphs that follow, we briefly summarize the findings of these empirical works.

The study [S43] compares EPC, BPMN, and UML activity diagrams with respect to their influence on model understandability. The participants of the experiment reached lower scores in EPC models compared to models in UML and BPMN. However, some studies, such as [S29], argue that the impact of using EPCs or BPMN notation in terms of model understandability is insignificant. In a test presented in [S28], where participants had knowledge of only EPC notation, process model comprehension was measured for BPMN and EPC models. No significant difference was observed for understandability task effectiveness, efficiency, and perceived ease of use. The study concludes with an argument that if the users of process models are comfortable with either of the modeling notations adopted by their organizations, there is no need to switch to another notation [S28]. Similarly, the results of the experiment in [S14] with 23 participants, indicated no significant difference between UML Activity Diagrams and EPCs diagrams in terms of their understandability.

The study [S38] compares two process modeling notations, EPC and Petri-nets, focusing on their approaches in representing the control-flow aspect of processes. The experiment involved 50 students with business and economy background. The process model understandability was quantified using model comprehension (effectiveness), perceived ease of use and intention to use. Significant differences were found in all three indicators favoring the EPC notation. However, the study discusses the use of a particular group of students in the experiment as a limitation, as students' motivation and learning style might not represent the population of the end-users in practice.

In an experiment in [S9] four different symbol sets derived from EPC, UML Activity Diagrams, YAWL and BPMN are compared. The results showed that the notational deficiencies have a significant effect on process model understandability.

The study [S39], which compares BPMN and HPN (Health Process Notation) for their model understandability, indicates that -with respect to understandability task effectiveness, HPN provides better results for complex questions, whereas BPMN provides superior results for simple questions. With respect to the understandability task efficiency, HPN's scores

were significantly better. However, no statistically significant differences were revealed for the subjectively measured indicators of perceived ease of use and perceived usefulness.

There are also works that investigated the understandability of behavioral diagrams in UML. The study [S13] examines the understandability of UML sequence and collaboration diagrams, and concludes that there is no statistically significant difference between using any of these when their understandability is of concern. Similarly, the study [S22] compares three UML diagram types that are used to represent the dynamic behavior, UML sequence, collaboration, and state diagrams. No significant difference was found between these notations in terms of the way they influence model understandability. In [S26], five independent notational variations differences in the notation used for UML collaboration diagrams are compared. Each notational difference has two variations with identical semantics. The results indicated a significant effect of notational variations on the understandability task effectiveness, understandability task efficiency and the intention to use.

In [S31], a family of controlled experiments was conducted to evaluate the level of formality in workflow modeling. For this purpose, two styles representing different levels of formality were used: a precise style and an ultra-light style for UML activity diagrams. Analyses showed that the precise style yielded significantly better understandability task efficiency results but the style used for modeling had no significant impact the on understandability task efficiency.

The study [S21] examines the semantic comprehension of UML and OML (OPEN Modeling Language) from the perspective of dynamic modeling – in particular, based on the interaction and the state diagrams of these two language families. The findings of the experiment with 64 students indicate that, for both model types, the specification of the dynamic behavior using OML was faster and easier to understand (understandability task efficiency and effectiveness, respectively) than using the UML language. This is attributed mainly to the availability of logic boxes in OML to handle branching, looping and exceptions.

The work presented in [S44] studies the effect of using the RUCM (Restricted Use Case Modeling) approach on process model understandability. RUCM includes a set of well-defined restriction rules and a modified use case template. To test this effect, two treatments were used, with and without the use of RUCM. The results demonstrated that there were significant differences in terms of understandability between two treatments in favor of the use of RUCM.

Other types of process modeling notations were also subjects to empirical works on model understandability. In [S15], a goal-based modeling language *Tropos* was compared with a scenario-based modeling language, i.e. the UML use case diagram. The understandability questions involved 14 questions that were asked to 79 subjects in three runs of an experiment to test participants' comprehension level and effort. Tropos models were found more understandable than use case models as measured by the understandability task effectiveness. However, the difference was not significant for understandability task efficiency. In [S16], the understandability of graphical and textual declarative process models were compared. The results indicated that the graphical representations were easier to understand as measured by understandability task effectiveness, efficiency, and mental effort. In a similar study [S23], authors examined the strengths and weaknesses of graphical

and textual notations and compared the relative understandability of four alternative representations. The results indicated that the understandability was achieved best when the graphical models are complimented with the textual descriptions of a process (and vice versa). The study shows that the textual and graphical notations are complementary in nature.

PMF 2. Structural Complexity

Increasing complexity in process models are considered to result in reduced understandability, increased number of errors and defects, thus leading to the need for more effort to develop and maintain the process models (Rolon, Cardoso, Garcia, Ruiz, & Piattini, 2009). A research conducted on nearly 600 process models shows that larger process models tend to have more defects (Mendling et al., 2008).

The literature suggests several metrics to operationalize the structural complexity of process models. The *control-flow complexity* (CFC) and *size* are the two most commonly referred metrics in the literature. However, our review of empirical studies in this work revealed several other metrics including cross-connectivity and token splits [S33], structuredness [S6], [S33], diameter, density, depth and sequentiality [S33], [S36], connectivity and separability [S8], [S33], [S36], average connector degree, maximum connector degree, mismatch and connector heterogeneity [S33], [S36], [S37].

Although in some of the empirical works that we examined, the effect of the structural complexity factor (as measured using several metrics) resulted conflicting findings, we see an confirmed convergence to a conclusion which supports the influencing role of model's structural complexity on its understandability. In the following paragraphs, we briefly summarize these findings mentioning also the metrics used in quantifying the structural complexity.

The study [S35] reports a significant correlation between the complexity as measured by the CFC metric and the understandability of BPMN models in terms of understandability task effectiveness and understandability task efficiency. The CFC metric takes into consideration the number of decision points in the control-flow, i.e. XOR-split, OR-split and AND-split constructs in the BPMN models.

The studies [S33], [S36], and [S37] use two metrics (apart from others) as representatives of the structural complexity of process models: maximum connector degree and connector heterogeneity. The *maximum connector degree* denotes the maximum sum of incoming and outgoing arc of the connector nodes in a process model. The *connector heterogeneity* denotes the extent to which different types of gateway constructs are used in a process model. The study [S33] found no significant influence of complexity measured using these two metrics on the understandability as measured using understandability task effectiveness. However, in [S36] and [S37] the complexity (as measured using these metrics) was found to influence the process understandability significantly (i.e. high maximum connector degree was correlated with decreased understandability, and lower variety of gateways used in a model was correlated with increased understandability). In [36], the results also showed that the values of size and diameter have significant impact on the understandability task effectiveness. Similarly, the size, connectivity, diameter, density, average connector degree, mismatch, depth, and sequentiality have significant impact on the understandability as measured by the understandability task efficiency.

The study [S33] examines also the effect of other metrics of structural complexity on process model understandability. The statistical analyses demonstrated a significant correlation between the density, average connector degree, and cross-connectivity metrics and the process model understandability as measured by understandability task effectiveness.

The study [S37] focuses on the gateway complexity due to the importance of gateways in the complexity of process models. The study involves a controlled experiment conducted to identify threshold values for a specific set of structural metrics. Ten BPMN models were used, each with a different values of gateway complexity. The statistical analyses showed that the control-flow complexity, gateway mismatch, average gateway degree, gateway heterogeneity, maximum gateway degree (as discussed above), and the total number of gateways influence understandability (as measured by the understandability task efficiency). Moreover, threshold values for the structural metrics were obtained to identify process models of good or poor quality in terms of process model understandability.

In [8], two metrics of structural complexity were examined for their correlation with understandability: connectivity and separability where connectivity between two elements is calculated as the number of arcs between two elements minus 1 (with the assumption that it equals to 1 if two elements are inside the same control block) and high separateness is accepted as existence of a cut-vertex between elements. The complexity as measured using the connectivity metric was found to influence understandability negatively (as measured by understandability task effectiveness and cognitive load). However, separability did not have such correlation.

The study [S6] compares structured and unstructured process models in terms of their influence on process model understandability as measured by the understandability task effectiveness. *Structuredness* is relevant to structural complexity and denotes the extent to which a process model is built by nesting blocks of matching split and join gateways. It requires that split gateways have always a matching join gateway and these pairs are nested within each other. Structuredness is a desired property as unstructured process models tend to have a higher probability of having errors (Laue & Mendling, 2010). The study [S6] found out that structured model was more understandable, as long as structuring a process model does not increase the number of gateways more than the number of gateways in the unstructured version of that model [S6]. However, another study [S33] showed no significant effect of being structured on the understandability of process model.

Studies [S5], [S11], and [S12] examine the effect of structural complexity on the understandability of UML state diagrams. A set of metrics, such as control-flow complexity and size, were proposed to measure the structural complexity of the state diagrams. The results indicate no significant correlation between structural complexity and understandability.

The study [S27] investigates the structural complexity as a moderator factor on the relationship between the *use of gateways* and understandability task effectiveness and efficiency. The results indicate a significant moderation effect of the structural complexity on the mentioned relationship.

In [S42], the structural complexity is investigated both as a direct factor and a moderator factor that moderates the relationship between size and understandability. The diagram size (with two levels: small and large) was defined as the number of elements in a diagram,

weighted by their complexity. The results indicated that the size influences the understandability task effectiveness negatively. The influence of layout quality on understandability task effectiveness was strengthened with increasing diagram size.

PMF 3. Modularity

Hierarchy through the use of sub-processes has widely been considered as a practical means to deal with the size and complexity of models [S45] and (Reijers & Mendling, 2008). Many modeling languages allow for the design of hierarchical/modular structures (e.g. sub-processes in BPMN and EPCs). Hiding less relevant information in sub-models is expected to decrease the mental effort (cognitive load) needed to understand the model (Moody, 2004), whereas fragmentation due to modularization increases the mental effort by forcing the reader to switch attention between different fragments (so called the split attention effect [S45]). In consequence, the discussions about the proper way of using modularity and its implications on the understandability of models are not conclusive [S7], [S34], [S45].

The works by Reijers et al. ([S34] and (Reijers & Mendling, 2008)) tested the influence of using sub-processes on the understandability of two real-life processes that are modeled using Workflow Nets in two forms: modular and flattened. The participants (28 consultants) were asked to answer a set of (control-flow related) understandability questions regarding these models (to measure effectiveness). For the first process model, the experiment did not result in a significant difference between the modular and flattened versions, but a positive influence of modularity on understandability was found for the second model. The authors attribute this to the difference in the degree of modularization applied in these models. As the second model had more sub-processes, they sparingly conclude that ‘modularity appears to have a positive connection with process understanding’.

The study [S45] tests the effect of modularization on the understandability of *declarative* process models. Four processes were modeled in two forms (modular and flattened) using a declarative language DecSerFlow (W.M.P. van der Aalst & Pesic, 2006). The understandability is measured using the understandability task effectiveness, and the (perceived) mental effort. The results suggest that modularization decreases perceived mental effort but has no influence with respect to task effectiveness. The limited number of participants (9 respondents) is reported as a threat to the validity of the findings.

The study [S7] uses expert evaluation approach (with 15 process modeling experts) to determine whether some visualization strategies provide a better fit for representing process model hierarchies than others. Accordingly, the experts preferred to navigate in the hierarchy with the help of an *overview+detail* strategy (where sub-processes are shown as separate models detached from the context of the higher level model) instead of a *focus+context* strategy (where sub-processes are expanded in the higher-level model directly within their context). The ‘overview+detail’ view was considered to simplify the design and provide undistorted views on focus and context.

The study [S3] presents a family of experiments investigating the effect of hierarchy on the understandability of UML state diagrams. The results indicated insignificant or varied effects of hierarchy on understandability. Moreover, the study [S4] reports a worsening understandability with the increase of the nesting level (depth of hierarchy).

This diversity in the results can be attributed to the outcome of two opposing effects of modularization: *abstraction* (information hiding) and *split-attention effect* (browsing costs) (Reijers et al., 2011; Zugal, Soffer, Pinggera, & Weber, 2012). Using sub-processes might increase reader's understanding of a complex model by abstracting away less relevant information (and thereby reducing complexity). However, additional cost (increased cognitive load) incurred in browsing through and integrating fragmented pieces of models can counter-balance this gain (Figl et al., 2013) as it has been demonstrated that a user of a process model understands visual models by decomposing into smaller chunks which correspond to sub-processes and then connecting those chunks later (Moody, 2004; Sweller, 1994).

The impact of modularity on process model understandability has been examined using different process modeling languages, such as UML Statechart Diagrams [S3], [S4], Workflow Nets [S34], and DecSerFlow [S45]. In particular, there is a lack of studies on the effect of modularity that involve EPCs or BPMN - de-facto process modeling notation in practice (Harmon & Wolf, 2014). BPMN v2.0 has specific elements and techniques for representing modularity (e.g. collapsed/expanded sub-processes, groups) which have not been addressed in the research concerning process model understandability.

PMF 4. Modeling Approach

The factor of modeling approach relates to a diverse set of dimensions regarding the methods used in modeling the processes. This typically includes the primary focus of attention or the main driver in modeling the processes. These approaches in process modeling include, for instance, the declarative vs. imperative modeling approaches [S25], object-oriented vs. process-oriented [S1], or artifact-centric (Nigam & Caswell, 2003) vs. activity-centric vs. role-centric (Turetken & Demirors, 2011) approaches. It is often the case that different approaches use (or sometimes require the use) of different process modeling notations. In that respect, such studies inherently test the understandability of process models represented by different modeling notations (which are typically common and - in many cases - representative for the modeling approach). However, the primary focus and the eventual factor under investigation in these works are typically the modeling approach rather than the notation. The studies that we analyzed indicate a significant impact of the modeling approach on the understandability of process models [S1], [S24], [S25].

In [S1], semantically equivalent OO (object-oriented) and PO (process-oriented) models were used in an experiment and the understandability of models were compared in terms of the accuracy of understanding. The study found that a PO model is more understandable, but only for questions involving both structure and behavior questions.

The study [S24] compares two methods; OPM (Object-Process Methodology) and OMT (Object Modeling Technique) in terms of understandability. A controlled experiment was conducted with 88 students, where the understandability was measured by the participants' responses to a questionnaire consisting of 33 questions. Statistical analyses showed significant differences between two methods and a single model methodology. OPM was found to be more understandable than a multi-model methodology OMT. Moreover, most of the participants preferred OPM to OMT.

Following a similarly approach [S25] examined the understandability of the imperative and declarative process modeling approaches. The understandability has two dimensions in this

empirical study, accuracy and speed. Statistical tests demonstrated that imperative models are more understandable in terms of accuracy and speed than declarative models.

PMF 5. Visual Layout

Several works stress on the importance of the visual layout of a process model as an influential factor for user's understanding of the process model (Bernstein & Soffer, 2015). Bernstein and Soffer (2015) identified a set of key visual layout features of process models, derive metrics from these features, and applied to example process models. However, there are also a number of empirical works that investigated the importance of this factor, e.g. [S40], [S41] and [S42]. These three works derive their results from a series of experiments with 78 participants.

The study [S40] uses UML use case and activity diagrams, where [S41] and [S42] use UML sequence and state diagrams as experimental materials. The quality of layout of process models used in the experiments was measured by the compliance or non-compliance to a number of layout rules, and had two levels, good layout and bad layout. The results indicated that the visual layout has a significant effect on the understandability task effectiveness, efficiency, and intention to use. The studies [S41] and [S42] using other types of diagrams reached similar results, i.e. a good layout increased process model understandability.

PMF 6. Model Element Labeling

Individuals handle information better it is provided through both auditory (i.e. words) and visual (i.e. images) channels. According to this observation, it can be expected that process model understanding can be improved when a better guidance for process model element labeling is provided. The study [S18] found that verb-object style labels (e.g. export license check) are regarded as more useful for understanding the process model than action-noun style labels (e.g. notification printing) or rest style labels (e.g. status analysis cash position) for activity labeling.

In [S19], the effects of the use of abstract versus concrete activity labels on the understandability task effectiveness (or performance) and understandability task efficiency were examined. Authors expected that comprehension occurs quicker for people dealing with process models with abstract textual labels as they require less effort to retrieve and assemble pieces of information, when only having to consider graphical constructs but not additional textual information. It was found that both understandability task performance and understandability task efficiency were improved when activity labels were omitted.

PMF 7. Model Element Design

Process modeling notations support the expression of convergence and divergence semantics by using different visual symbols. The study [S10] tests several hypotheses regarding the effects of perceptual discriminability, pop out, semantic transparency and aesthetic design of routing symbols on process model understandability. The findings indicated that routing symbol design principles influence the understandability task *effectiveness*, but have no significant influence on the task *efficiency*.

PMF 8. Use of Modeling Guideline

The work [S2] studied the effect of using modeling guidelines on the understandability. For this purpose, an experiment was conducted with 139 students. Three different sets of guidelines were used to construct and document use case models. In order to evaluate understandability, the participants answered questions about the functionality in the use case models developed by different guidelines. A significant difference in understanding when reading use case models constructed with different guidelines was attained. Also, a significant difference in the usefulness of different guidelines was found.

PMF 9. Use of Model Annotation

In [S20], a context-based process semantic annotation model was proposed and the effect of this annotation model on the searching, navigation and understanding of process models was tested. The results indicated no significant difference between the annotated and *un-annotated* process models in terms of understandability task effectiveness. However, most users perceived the annotated models as easy to use and useful for searching, navigating and understanding process models. Users had an intention to use the proposed annotation model for better understanding.

PMF 10. Modeling Construct Type Used

There have been only few works on the effect of using different generic process modeling constructs. In an experiment conducted in [S27] with 98 students (of information systems program), it was reported that the understandability of process models decreases when the gateway constructs were not used. In this study, the three process models delivered to subjects had abstract activity names such as task “A” in order to neutralize the impact of domain knowledge.

PMF 11. Use of Coloring for Model Elements

In [S32], the authors conducted an experiment to determine the effects of syntactical element highlighting on the understandability process models. The study argues that the use of colors to highlight matching operators has two advantages to improve understandability. First, it helps to identify a decomposition of the process model into components that enhances information hiding and, second, it helps to interpret secondary notation quickly since color can be processed by the humans much faster than graphical constructs. The study found that highlighting of matching operators has been found to influence understandability task effectiveness positively for novice process modelers. However, the influence is insignificant when the understandability task efficiency is concerned.

PMF 12. Process Perspective Representation

The control-flow aspect of processes is often the primary and the only perspective represented in process models. However, in some cases it may be useful (or even required) to model data and resource perspectives of processes as separate models or incorporate them in models that show control-flow information. Visualizing the data objects and resources in the form of organizational units in process models with satisfactory readability and granularity on the available space poses challenges to the understandability of these models.

In [S17], three visualization techniques - single view, multiple views, and multiple views in connection with linking and brushing, were investigated for their influence on process model

understandability. Single-view shows all three perspectives blended on the same process model. In multiple-view, these perspectives are represented in different models (control-flow model, data model, resource model) and shown to the user at the same time. The third technique enriches the multiple-view with 'linking' and 'brushing'. The presentation is in such a way that if items are selected or highlighted in one view (brushing), the corresponding connected items in the other views are also selected and highlighted (linking). Each participant in the experiment evaluated five processes modeled using a basic process modeling notation for each perspective. Four indicators were used to quantify understandability: understandability task effectiveness, perceived ease of use, perceived usefulness and intention to use. Statistical results showed that, although these models showed no significant difference in terms of understandability task effectiveness, the visualization technique of showing multiple-views in connection with linking and brushing was preferred over single-view and multiple-views in terms of usefulness and ease of use.

2.5.2 Personal Factors

The research confirms the significant impact of personal factors on process model understandability. Some researchers even argue that the personal factors have higher impact on process model understandability than the process model factors (Reijers & Mendling, 2011).

PF 1. Modeling Experience

Modeler's expertise is often considered as an important success factor of effective process modeling and critical for a successful BPM project (Bandara, Gable, & Rosemann, 2005). A global survey with 529 BPMN users about the effect of modeling expertise on the perceived usefulness and perceived ease of use of a process modeling grammar reinforces the importance of this factor (Recker, 2010). The study shows that experienced process modelers can refer to their experiences for challenging modeling cases and interpreting complex process models. On the other hand, for the less experienced modelers, the lack of this experience influences their effectiveness and efficiency of understanding in the opposite direction (Mendling, Strembeck, et al., 2012). According to the resource allocation theory (Kanfer, Ackerman, Murtha, Dugdale, & Nelson, 1994), the users that built up experience in modeling require less cognitive load in performing model-related tasks. Hence, some studies suggest to take different levels of expertise into account in providing guidance for process modelers (Gassen, Mendling, Thom, & de Oliveira, 2015).

Typical operationalization of the modeling expertise involves *modeling experience* and *modeling intensity* to distinguish between modelers that have modeled for a long time and those that model often [S19].

The study [S29] tests the effect of modeling experience on understandability (as measured by task effectiveness and efficiency) by taking into account two aspects: transfer ability and retention ability. Transfer ability test measures deep understanding, while the retention ability test quantifies surface understanding. The experiment involved 68 postgraduate IS students, who were asked to indicate their modeling experience by estimating the number of process models that they have created or worked with. The participants were divided into two groups, above and below the median, corresponding to 36 and 32 participants. The results indicated that higher experience in process modeling resulted in significantly higher scores on the transfer ability, while it had no effect on retention ability scores (i.e. task

effectiveness). With respect to task efficiency, the transfer and retention ability task completion times were not significantly influenced by the modeling experience.

In [S31], modeling experience was considered as a factor that potentially influences the understandability of UML activity diagrams. A significant effect of experience on the understandability (as measured using task effectiveness) was observed, indicating that the experienced people understand the workflows better.

The study [S41] presents three experiments with 78 participants in total, where the effect of process modeling experience on the understandability of a set of UML diagrams (sequence, state and class diagrams) was tested. The analyses showed that the task effectiveness increases with the increasing experience level (as measured in three levels: beginner, advanced and elite).

In [S42], the influence of modeling experience was investigated both as a direct and a moderator factor. The results indicated that the expertise level has a direct and significant effect on the understandability. As for the moderation effect, the findings show that subjects with higher modeling experience are much less affected by the increasing diagram size and poor layout than subjects with lower modeling experience.

However, there is also an important work in the literature that were not able to confirm this relationship. The study [S19] examines the effect of modeling experience and intensity on process model understandability (as measured by understandability task effectiveness and efficiency). This work quantifies experience using four levels: less than one month, less than a year, less than three years, and longer than three years. The intensity also uses four levels to quantify the frequency of encountering process models in practice: daily, less than once a month, more than once a month, and never. The findings indicate no significant effect of the modeling experience and intensity on understandability task effectiveness, while the intensity influences the understandability task efficiency significantly.

Likewise, in [S33], the modeling expertise is operationalized using the intensity of modeling, which is measured on a four-point ordinal scale ranging between “I never use business process modeling in practice” and “I use business process modeling in practice every day”. The findings suggest no significant effect of modeling intensity on model understandability as measured by task effectiveness.

PF 2. Knowledge on Process Modeling and Notation

This factor represents a person’s theoretical knowledge on the general process modeling concepts and on the specific modeling notation used. This factor is typically measured as a self-assessment by the participants of the experiments (as in [S33]) or in a more reliable way - using a short theoretical knowledge test to be answered by the participants (as in [S19]).

In [S33], the respondents self-assessed their theoretical knowledge on process modeling on a five-point ordinal scale, with anchor points “I have weak theoretical knowledge” and “I have strong theoretical knowledge.” The findings indicate no significant influence of this factor on understandability task effectiveness. The study [S18] follows a similar approach to quantify respondents’ knowledge on a particular modeling notation. Based on self-assessments, the participants were put into two groups; high and low familiarity with the notation. This work investigates the knowledge of process modeling notation as a moderator

factor on the relationship between labeling style and perceived usefulness. The analysis of 174 responses coming from 29 subjects indicate no significant effect of this factor on the relationship between label type and perceived usefulness.

On the other hand, the study [S19] used a knowledge test to subjectively measure respondent's level of knowledge on process modeling and the modeling notation. Accordingly, this factor positively influences both understandability task effectiveness and efficiency.

PF 3. Professional Background

In the business process understandability research, the professional background represents a broad concept, which is typically used to categorize participants' domain of work or education. In [S33], for instance, this factor is investigated as a categorical variable referring to the educational institute that the respondents are registered at. The results of the experiments indicated that students with different backgrounds- in terms of the university & department that they are registered at, scored significantly different results in terms of model understandability. However, as the authors acknowledge that these students took different level of courses on process modeling, one can argue that this factor – as designed in this study, relates heavily on other personal factors – particularly to the factor of knowledge on process modeling and notation.

The study [S39], however, operationalize this factor arguably in a more representative way, with respect to its definition. The participants are referred to as those with an engineering background and others that have a background in healthcare. On the other hand, the results demonstrated that professional background does not have a significant impact on understandability task effectiveness, understandability test efficiency, perceived ease of use, or perceived usefulness. On the other hand, a significant interaction between the process model (BPMN or HPN modeling notation) and professional background was found out. In particular, engineers understood simple items better with the BPMN process model.

PF 4. Cognitive Abilities

A free simulation experiment was conducted to test the effect of individual cognitive abilities on process model understandability [S30]. Cognitive abilities was operationalized by abstraction ability and selection ability. Abstraction ability allows an individual to constitute an abstract model for an entity of the external world (Bennedsen & Caspersen, 2006) where selection ability enables an individual to search through a set of objects, attributes or relations in typically large diagrams with many informational artifacts (Winn, 1993). Selection ability and abstraction ability were found to influence process model understandability in opposite directions, the first one in positive direction and latter one in negative direction.

PF 5. Learning Style

Users can process information in several ways such as by seeing and hearing, reasoning logically or analyzing graphically in terms of learning style (Felder & Silverman, 1988). As users learn from a (graphical) process model, learning styles of users are considered as a factor in [S30]. Felder and Silverman (1988) examined the differences between sensing and intuitive learners. Sensing learners tend to memorize materials where intuitive learners are

more comfortable with abstractions and prefer discovering possibilities and new relationships (Felder & Brent, 2005). A sensing learning style was compared with an intuitive learning style to test the effect of learning style on process model understandability [S30]. A sensing learning style was found to be better than an intuitive learning style in terms of understandability task effectiveness.

PF 6. Learning Motive

Learning motive indicates a person's desire in learning process and determines the person's perception of requirements of learning. Two types of learning motive can be identified, surface motive or deep motive (Kember, Biggs, & Leung, 2004). A *surface motive* is triggered by extrinsic motivation such as aiming to meet expectations of superior. The relationship between surface learning motive of a user and process model understanding performance was examined in [S30]. It was demonstrated that a surface learning motive negatively influenced process model understandability.

PF 7. Learning Strategy

The effect of learning strategy of a user on process model understandability was investigated in [S30]. In this context, the learning strategy indicates to making a plan about how to learn from a process model. A *deep learning strategy* aims at developing a thorough level of understanding for solving complex tasks and enables discovery of new knowledge. A *surface learning strategy* implies simple learning. The individual tries to memorize the content of the process model without questioning it. Surface learning strategy was found to increase process model understandability.

PF 8. Domain Familiarity

In the software engineering field, the research confirms the effect of prior knowledge of the application domain on the understanding of software source code (Lakhotia, 1993). According to the Cognitive Theory of Multimedia Learning (CTML) (Mayer, 2001), prior knowledge of the domain covered in a conceptual model lowers the cognitive load required to develop a mental model of the information represented in the model. As a result, it becomes easier to understand the model.

The study [S18] investigates the moderation effect of the domain familiarity on the relationship between labeling style and perceived usefulness. The respondents were categorized into two groups based on their self-perception: those that have high application domain knowledge and those that have low. However, the findings of the analysis show no significant moderation effect on the relationship between labeling style and perceived usefulness.

2.6 Discussion

This systematic literature review reports on the factors investigated in the literature that are considered to influence the understandability of business process models. In doing so, it also reviews how process model understandability is operationalized in the literature. We performed searches on the established electronic libraries for potentially relevant studies published between 1995 and 2015. A total of 1.066 publications were identified following the searches in 6 electronic libraries. We selected 45 primary studies based on inclusion and

exclusion criteria. Based on our two research questions; we extracted data and empirical evidence from the studies and synthesized them to answer our research questions.

Our first research question involves the way the process model understandability is operationalized in the literature. We investigated 6 indicators that the researchers used to measure the understandability of process models. Accordingly, the understandability task effectiveness is the dominant indicator used to quantify understandability. The typical setup to compute this indicator involves a set of representative understandability questions related to the process models used in the experiments to be answered by the participants. Tracking the time that participants spend in answering these questions forms the basis for another commonly used indicator – the understandability task efficiency. The set of indicators used for process model understandability also involves subjective measures, such as the perceived ease of use, that are based on technology acceptance models. These indicators aim to capture participants' perception mainly on the level ease of use and usefulness of the process models for understandability.

Our review of literature can act as a reference to bring about a more consistent understanding of the concepts and use of terminology in process model understandability. Practical guidelines on operationalizing understandability would help researchers in designing, conducting, and reporting on sound and valid experiments. This can also allow comparing results of different empirical studies. A standard way of reporting on an experiment would provide valuable information on the review of articles, replication of the experiments, and analysis, comparison and interpretation of the findings (Sjoberg et al., 2005).

To answer our second research question, we had a detailed look into the factors that have been investigated in the literature using empirical methods. Apart from the general findings on the type and the composition of the participants in each work, we derived a list of factors that have been tested for their influence on process model understandability. We thoroughly analyzed the studies to identify these factors. We looked how a factor was operationalized, how its effects were tested (direct, moderation), whether the factor was found to influence the understandability, and if so how. Reviewing 45 primary studies, we identified 20 factors investigated in the literature. Aligned with the literature (Mendling, Strembeck, et al., 2012), we categorized these factors into process model and personal factors. We reported on the findings for 12 process model and 8 personal factors.

The results of our empirical study gives an insight on the body of research on the factors of business process model understandability. The studies that compare process modeling notations in terms of their influence on the understandability form the majority of the empirical works in this field. The next commonly investigated factor is the structural complexity of the process model, which has been measured using various metrics. There is a shared consensus in the community about the negative influence of the structural complexity on model understandability. However, the comparative studies among process modeling notations are far from agreeing on the notations that are more understandable over the others, nor they provide a clear insight on the characteristics of process modeling notations that contribute or deteriorate understandability.

Looking further at the influential factors, we observe that the *process model factors* have been intensively investigated, while the *personal factors* have received less attention. Very few studies investigate the combined influence of process model factors and personal factors and their relationships. Majority of the experiments reported in the literature use process

models of different size and complexity, and with participants of different background (e.g. student, practitioner), process modeling experience, and knowledge. Contradictory findings in these studies signify how complex the interrelationships between these factors are. There is a need for comprehensive empirical works that uncover the relationships between influential factors to understand the context under which such factors become effective in improving or hindering model understandability. For instance, we know little about the thresholds for various metrics of process model size and complexity over which the understandability of a BPMN process model starts deteriorating for a particular audience with certain BPM expertise and knowledge. Lack of such studies prevent us in synthesizing clear and practical guidelines for creating understandable process models.

Our analysis showed that using students in the experiments is the dominant approach in the field. Majority of the studies used student populations (88% of all participants in 45 studies) arguing that they are adequate proxies for novice analysts (Burton-Jones & Meso, 2008). However, using students has also been criticized for posing threats to the generalizability of the findings (Kam, Wilking, & Zechmeister, 2007). Apart from the varied level of motivation of practitioners and students in participating in such experiments, using students may pose difficulties in testing some influential personal factors, such as the modeling expertise, field experience, domain familiarity, and professional background, due to a certain level of uniformity in student populations. In addition, our analysis showed that around one-third of the studies were conducted with fewer than 35 participants. Although there is no prevailing rule on the number of participants required in such empirical works, enlarging the respondents' base will increase the validity and generalizability of the studies. In particular, conducting experiments with industry practitioners will help in gaining a better understanding of the factors and in yielding results that are applicable and more appropriate for its intended audience.

The review of the literature also reveals the lack of empirical works on a number of potentially influential understandability factors. For instance, the effect of the *medium* used to present the models to their audience has not been addressed in the literature. Although the *paper* is usually the preferred means for interacting with model readers in practice (Reijers et al., 2011), the models are typically designed using software applications, and communicated through an online environment (e.g. web portal, company intranet) across the organization and beyond. Therefore, it is important to explore if using paper or a *computer environment* has any effect on model understandability. Several additional features that the computer environment brings (such as information filtering/hiding, pop-up views, animation, etc.) each with hypothetically different influence makes this more challenging yet interesting to investigate.

The explicit purpose which the process model is built for can also be considered to impact the understandability due to the difference in the perspective and level of process information incorporated in the model. For instance, *executable* process models are not intended to be used on a day-to-day basis by humans as they are explicitly created for automatic enactment. Less care will be given to make such model understandable for people (Reijers & Mendling, 2011). The difference in the primary focus of attention and concern in such models are elaborated in Dehnert and van der Aalst (2004).

2.7 Conclusion

Our study surveyed the existing research on the business process model understandability and provides an overview of the state-of-the-art in this topic. Researchers and practitioners in the business process management community should consider our study as a comprehensive source that offers pointers on the factors investigated in the literature and a basis for future research in this field. Our findings identify several gaps where there is a potential for major contributions. The practitioners, who aim to generate understandable process models will benefit from our findings synthesized from the existing research in this field.

Yet, thorough analysis of the results of the studies in the field show that we still have limited knowledge on the factors contributing to *understandable* process models. The studies on factors influencing business process model understandability need to grow in maturity with more empirical studies (Recker & Mendling, 2015).

Our systematic review has various limitations mainly with regard to the underlying research method - in particular, due to the inclusion and exclusion criteria constructed and used in our systematic literature review. Our systematic review relies on certain types of publications in reviewing the academic literature. Studies that are published as (non-academic) books and grey literature (technical reports, white papers, work in progress, publications without bibliographic information, unpublished publications) were not included in this study. Another limitation is due to the language of the publications. Important or relevant studies might have been missed out in the non-English published articles. These two limitations are in line with the exclusion criteria of this systematic review, but pose risks for its completeness and for the validity of the results.



CHAPTER 3

3 RESEARCH METHODOLOGY

We have designed our study as an experimental research. An experiment is an orderly procedure carried out with the goal of verifying, falsifying, or establishing the validity of a hypothesis. Hypothesis is defined as a statement about a relationship between two variables. Experiments provide insight into cause-and-effect by demonstrating what outcome occurs when a particular factor is manipulated. In experimental studies, the independent variables are manipulated and the setting of the research is controlled by the researchers. Such studies require procedures that will not only reduce bias and increase reliability, but will permit drawing inferences about causality (Kothari, 2004). As we manipulate independent variables and measure the effect of this manipulation in order to test our hypotheses, we follow experimental research.

As Basili, Shull and Lanubile (1999), Miller (2000) and Shull et al. (2002) suggested, single studies rarely provide reliable empirical results. A family of experiments includes multiple similar experiments that target the same goal and builds the knowledge that is needed to extract significant conclusions that can be applied in practice (Basili et al., 1999). It is widely accepted that to achieve greater validity of empirical results, replications are necessary. Therefore, we planned to carry out a family of experiments. Our family of experiments consists of a controlled experiment and two replications of this experiment. Replications that reuse the original procedures (e.g., the study design and the experimental steps, but modify the subject pool in order to gain more in-sight into the original results - as in our case), fall into the category of exact replications.

Figure 7 shows the main tasks performed for our research. We have discussed the first two tasks in previous chapters. Based on the results of our literature review, we formulated our hypotheses for our research. To test these hypotheses, we have designed and piloted an experiment. We conducted three replications of the experiment with different participants and settings. Finally, we performed statistical analyses to test our hypotheses, and interpret and report on the major findings.

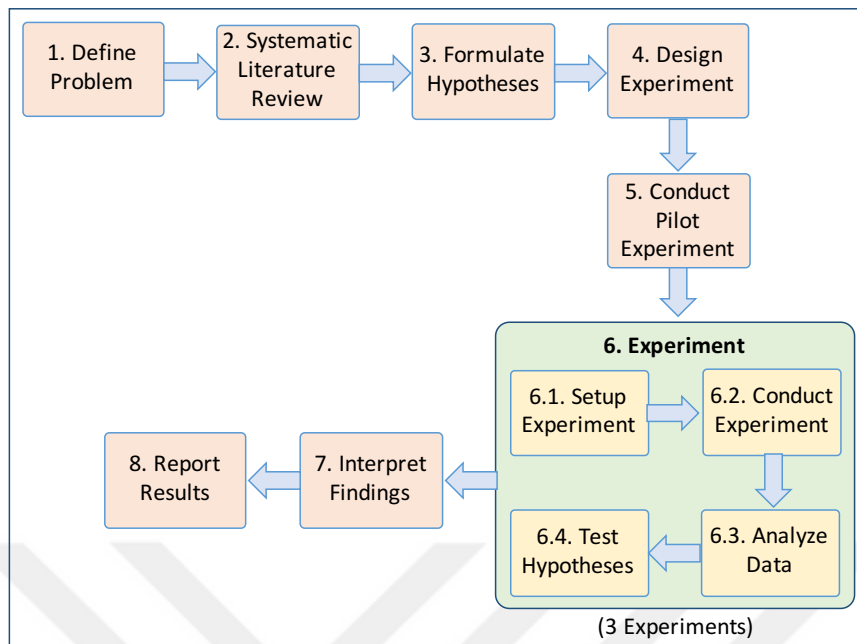

Figure 7 Research design

3.1 Research Model

To test our research hypotheses, we used a 3*2 between-subjects factorial design for the experiment, where separate groups of participants for each of the different conditions in the experiment were tested once only (Field & Hole, 2003). Aligned with our objective of our study, there are two main *independent variables* (which correspond to between-subjects factors): *modularity representation* (in 3 forms) and *presentation medium* (paper vs. computer). We defined four *dependent variables* that operationalize business process understandability: *understandability task effectiveness*, *understandability task efficiency*, *perceived usefulness for understandability* and *perceived ease of understanding*. We describe these variables in detail later in this chapter.

In an ideal situation, the dependent variables should only be predicted by the independent variables. However, the literature suggests a number of personal factors that may potentially influence model understandability (Wickens & Kramer, 1985). We consider these personal factors as *external variables* which potentially influence the dependent variables. To investigate the potential effects of these factors, we asked participants about their experience in process modeling (following (Mendling, Strembeck, et al., 2012)), knowledge on process modeling and BPMN and familiarity with the domain.

Figure 8 represents the research model that we tested in our experiments. The model proposes that the understandability of process models is influenced by the modularity technique applied in modeling the process, the medium used for its presentation, and personal factors such as BPM skills and capabilities or familiarity with the process domain. Accordingly, we can draw eight groups of hypotheses that are described below (the hypotheses in all of the groups are two-sided).

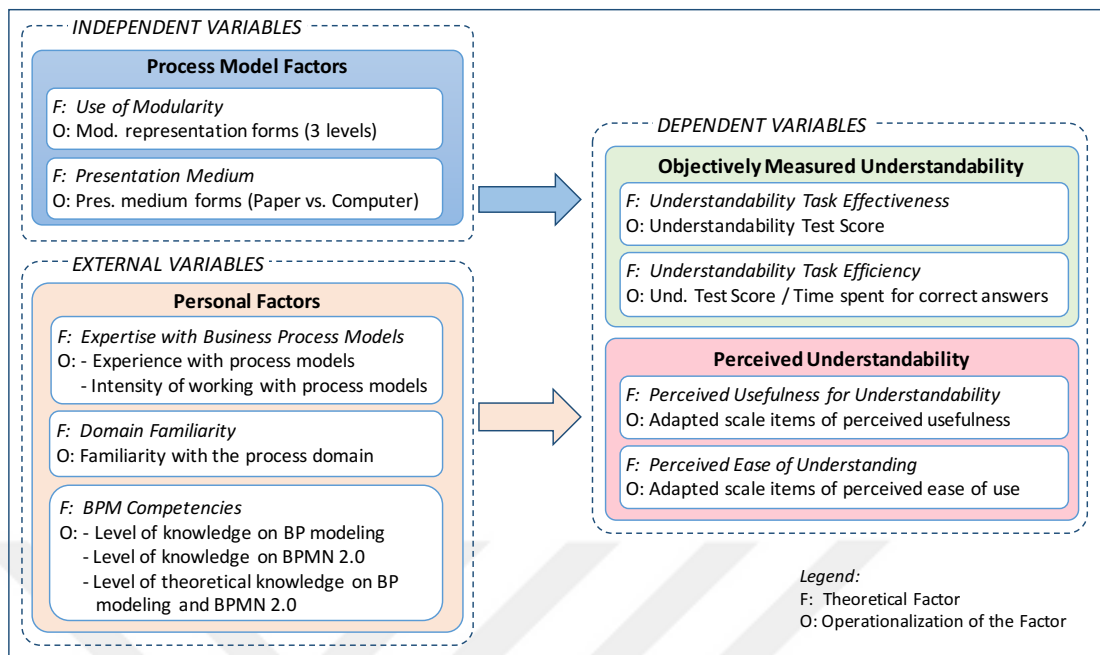

Figure 8 Research model

The first two groups of hypotheses relate to the independent variables; the *form of modularity representation* and the *presentation medium*, respectively.

H1. The *form of modularity representation* has a significant influence on the understandability factors, i.e.: (a) understandability task effectiveness, (b) understandability task efficiency, (c) perceived usefulness for understandability, and (d) perceived ease of understanding.

H2. The *medium used for presenting process models* has a significant influence on the understandability factors i.e.: (a) understandability task effectiveness, (b) understandability task efficiency, (c) perceived usefulness for understandability, and (d) perceived ease of understanding.

The remaining groups of hypotheses correspond to the external variables, i.e. the personal factors that are considered to influence understandability. These factors are based on the literature review that we discussed in Chapter 2.

The first personal factor involves participants' level of *expertise with business process models*. We used two metrics to operationalize this factor: participants' experience with process models and their intensity of working with them in daily work. They were asked to indicate how long they have been involved with business process models (measured on an ordinal scale with five levels: never encountered a process model, less than one month, less than a year, less than three years and longer than three years). For the second metric, they were asked to state how often they work with process models (ordinal scale with 4 levels: never, less than once a month, more than once a month, and daily) to measure their rate of encountering process models in practice. Accordingly, the following hypotheses are formulated:

H3. *Experience with process models* has a significant influence on the understandability factors i.e.: (a) understandability task effectiveness, (b) understandability task efficiency, (c) perceived usefulness for understandability, and (d) perceived ease of understanding.

H4. *Intensity of working with process models* has a significant influence on the understandability factors i.e.: (a) understandability task effectiveness, (b) understandability task efficiency, (c) perceived usefulness for understandability, and (d) perceived ease of understanding.

The second personal factor involves participants' level of *familiarity with the domain* to which the process model is related. This factor is measured on an ordinal scale with five levels (not all familiar, slightly familiar, somewhat familiar, moderately familiar and extremely familiar). Accordingly, we pose the following hypothesis:

H5. *Familiarity with process domain* has a significant influence on the understandability factors i.e.: (a) understandability task effectiveness, (b) understandability task efficiency, (c) perceived usefulness for understandability, and (d) perceived ease of understanding.

The third and final personal factor relates to participants' *BPM competencies* - particularly their theoretical and practical knowledge on business process modeling. We used three metrics to quantify this factor. First, the (perceived) *level of knowledge on BP modeling*, and second, the (perceived) *level of knowledge on BP modeling notation* (BPMN 2.0 in our case). Both have ordinal scales with four levels that has to be indicated by the participants (not knowledgeable about, somewhat knowledgeable about, knowledgeable about and very knowledgeable about). The third metric relates to the *level of theoretical knowledge on process modeling and BPMN v2* (as the modeling notation). This is measured using a questionnaire with 15 questions about process modeling and BPMN 2.0. Accordingly, the following hypotheses are formulated:

H6. *Level of knowledge on BP modeling* has a significant influence on the understandability factors i.e.: (a) understandability task effectiveness, (b) understandability task efficiency, (c) perceived usefulness for understandability, and (d) perceived ease of understanding.

H7. *Level of knowledge on the modeling notation (BPMN 2.0)* has a significant influence on the understandability factors i.e.: (a) understandability task effectiveness, (b) understandability task efficiency, (c) perceived usefulness for understandability, and (d) perceived ease of understanding.

H8. *Level of theoretical knowledge on BP modeling and BPMN 2.0* has a significant influence on the understandability factors i.e.: (a) understandability task effectiveness, (b) understandability task efficiency, (c) perceived usefulness for understandability, and (d) perceived ease of understanding.

In the sections that follow, we explain the details regarding the design of the experiments including the process models used for the experiments, the independent variables (forms of modularity representation and presentation medium), dependent variables regarding model understandability and their operationalization.

3.2 Process Models Used for the Experiment

We used two process models as the objects of our experiment. These processes are taking place in a large corporation headquartered in The Netherlands (which employs more than 115,000 employees and operates in over 100 countries worldwide).

Among several processes in the quality management system of the enterprise where the selected processes are being implemented (and the first experiment was conducted), two processes of similar size and nature were selected by the company representatives taking into account their criticality in the business domain in which the enterprise operates. The processes can be considered as large and rich in terms of the interaction taking place between different departments and divisions of the enterprise.

The selected processes were initially modelled in BPMN v2.0 using sub-processes where applicable (based on existing process documentation, and interviews with process owners and participants). The resulting models were BPMN collaboration diagrams, where the interaction between process participants (roles, organizational units, divisions) was explicitly modeled using message flows. The models were subsequently reviewed by process modeling experts for syntactical correctness, and validated for their semantic correctness (including the choice of modularization; i.e. sub-process structures) by the domain experts in the company, who were also knowledgeable about process modeling. The resulting process models are given in Appendix B.

BPMN presents a large set of constructs, significantly more than other popular process modeling languages (zur Muehlen & Recker, 2008) but many users understand and use only a small subset of constructs (Wil M.P. van der Aalst, 2012b). In line with this finding, a small subset of BPMN constructs are used for modeling these processes. Process modeling conventions are used to ensure that two processes are modeled in a similar way and to increase comparability and readability (Dumas et al., 2013). They will also enable repeatability of the experiments with other business processes. Process modeling conventions that are used are summarized in Table 35 in Appendix C.

Table 4 gives a selection of structural properties regarding the process models used as the objects of our experiments. Nodes are summarized in three types; activity nodes, gateways (control nodes) and event nodes according to the classification in Dumas et al. (2013). Activities describe a unit of work, gateways capture the flow of execution between activities, and event nodes give a signal that something may or must happen within the process. Arcs are grouped in sequence arcs and message arcs. Control-flow complexity is calculated as defined in Rolon et al. (2009) As it can be seen in Table 4, two process models are considerably similar in terms of size and structural complexity (the numbers of events, sequence arcs and message arcs are slightly larger in Process Model A than Process Model B and control-flow complexity is slightly larger in Process Model B than Process Model A). Both models are of considerable complexity.

Table 4 Structural properties of process model A and process model B

Metric	Process Model A	Process Model B
#Activity nodes	47	46
#Gateways	34 (8 AND split/join, 22 XOR split/join, 4 event-based)	38 (8 AND split/join, 27 XOR split/join, 3 event-based)
#Events	52	38
#Nodes (total)	133	122
#Sequence arcs	146	134
#Message arcs	27	18
#Arcs (total)	173	152
#Sub-processes	15	14
#Pools	5	5
Control-flow complexity	44	49

3.3 Forms of Modularity Representation

The verified and validated models were subsequently re-structured into two other forms using different modularity representations in BPMN 2.0, leading to three forms of representation to be tested. Figure 9 illustrates these forms. The first form (Repr1) is the fully-flattened representation of the process models. This type acts as the reference model which offers the possibility to draw conclusions about whether the use of any modularity technique has an influence on the understandability (Note that, re-structuring models does not affect the business logic in a semantic sense, but may influence the extent of information provided in the models. For instance, the sub-process information disappears in the fully-flattened models.).

The second form of representation (Repr2) combines the fully-flattened form with groups that informally cluster a logically related set of activities. We used groups in a way similar to the use of ‘expanded sub-processes’ in BPMN (but without the use of additional start/end events for each sub-process). This form shows some characteristics of a ‘focus+context’ view (as in Figl et al. (2013)), which is considered to require less cognitive load of the user, who usually has to integrate model parts again when sub-processes are extracted from the main model as separate models (i.e. in ‘overview+detail’ view). However, in this form, the complexity of the full-flattened model is inherited and amplified by the additional information on process groupings.

The third form (Repr3) is the *initial* representation for the models we used in the experiment, which addresses the size and complexity with the use of collapsed sub-processes in BPMN. The sub-processes are hidden in the higher level (main) process model, but can be accessed as a separate model whenever the user is interested in the information it contains.

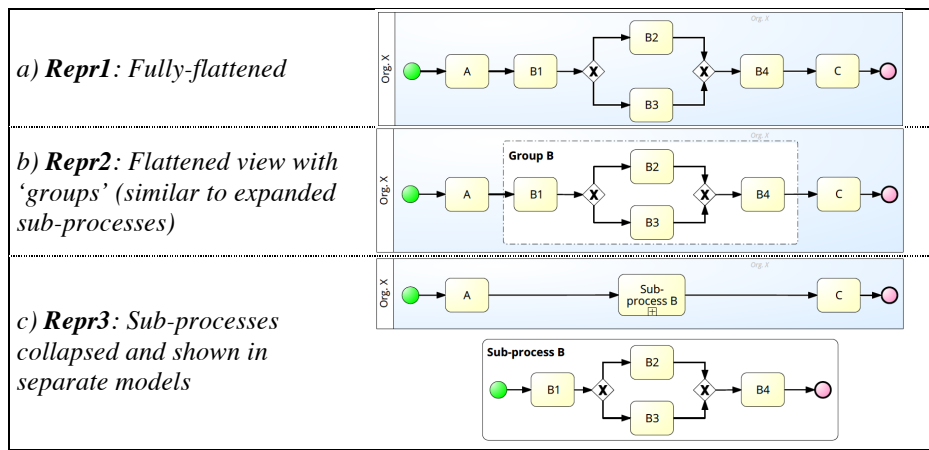

Figure 9 Three modularity representations: *a)* Fully-flattened [Repr1], *b)* Flattened view with groups [Repr2], and *c)* Sub-processes collapsed and shown in separate models [Repr3]

Repr1 and Repr2 differ in the way whether or not they divide the whole process model into sub-processes. Repr1 does not divide the main model into smaller models in that extent, whereas Repr2 splits the model into sub-processes. Repr2 is an expansion of Repr1 with the help of colored boxes aiming to improve understanding. Repr3 represents the sub-processes also defined in Repr2, in separate views.

Figure 10 shows example models of the processes A and B in two representation forms (Repr2 and Repr3), respectively. (Note that the figure is provided to give an indication of the size and structure of the models, and labels of all process elements that existed in the experiment are removed here. However, all versions of the process models with labels are given in Appendix B.)

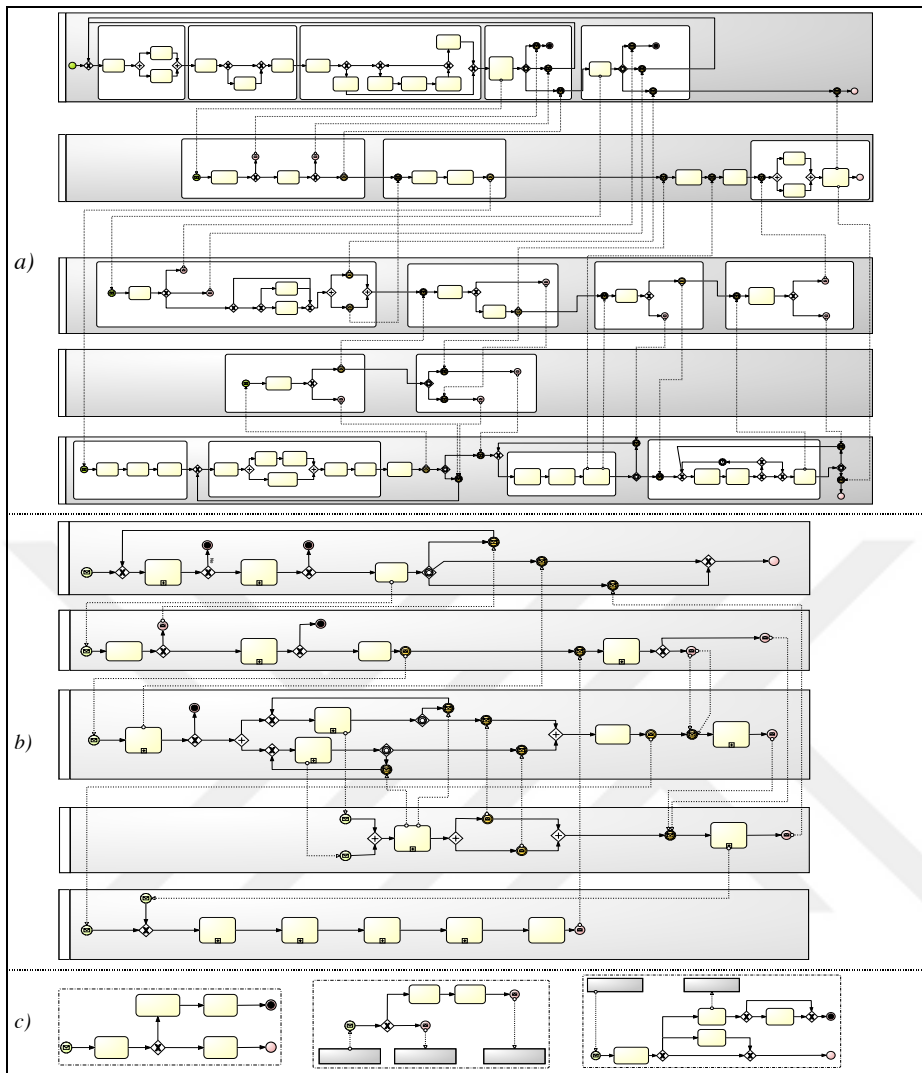

Figure 10 The process models in two forms of modularity representation: *a) Process A in Repr2 (flattened with groups of activities), b) Process B in Repr3 (with collapsed sub-processes), c) Few of the sub-process models of Process B in Repr3.*

3.4 Presentation Medium for the Process Models

We experimented with two alternative presentation mediums: paper and computer. Half of the participants were provided with the models on A3 size papers, which allowed for adequate readability. The sub-processes in Repr3 were also printed on separate A3 size papers with 6 sub-processes on each.

The other half of the participants received the models on the computer environment through an online website that can be accessed using a web-browser. The models with Repr1 and Repr2 (fully-flattened, and flattened with groups) were displayed as images, which can be zoomed and navigated in all directions. For the models with Repr3 (with separate sub-process models), a script was used to pop-up sub-process models when the mouse pointer hovers on the collapsed sub-process element in the main model.

3.5 Understandability Questions

In order to evaluate participants' level of understanding of the processes, 9 questions were developed for each process by following an iterative approach with the domain experts employed in the enterprise where processes are being implemented. This was to make sure that each question can be used as a representative and valid way to assess someone's understanding of the processes.

Since the quality of these questions has significant influence on the validity of the findings (Laue & Gadatsch, 2010), we paid particular attention on developing a set of questions that is balanced in relation to different *process perspectives* (i.e. control flow, resource, and information/data), and *scope* (i.e. global and local). Accordingly, there exists five types of questions according to scope:

- Information within the scope of a single sub-process is needed to answer a *local* question.
- Information about only a sub-process is needed to answer a *local-only* question.
- Information available in the modularized (high-level) model is needed to answer a *global* question.
- Information about only the modularized (high-level) model is needed to answer a *global-only* question.
- Information available not only in the modularized model but also in one or more sub-processes is needed to answer a *global-local* question.

Availability of these three types of questions is important particularly for the investigation of the potential influence of modularity (Reijers et al., 2011).

The distribution of questions according to process scope and perspective for process model A and B are given in Table 5 and Table 6, respectively. As it can be seen from these two tables, out of 9 questions (for each process), there are 6 global, 6 local, 3 global-only, 3 local-only and 3 global-local questions. The distribution of questions with regard to process perspectives is as follows: For process model A, out of 9 questions, 6 relate to control flow, 7 relate to resource, 6 relate to information, 3 relate to all process perspectives, 2 only to the control flow, 1 both to the control flow and resource, and 3 both to the resource and information perspectives. A very similar configuration is maintained also for Process B.

Table 5 Distribution of understandability questions for *process model A*

Question	Global	Local	Control Flow	Resource	Information
1	x	x	x		
2		x	x	x	x
3	x	x		x	x
4	x			x	x
5	x			x	x
6		x	x		
7		x	x	x	
8	x		x	x	x
9	x	x	x	x	x
Total	6	6	6	7	6

Table 6 Distribution of understandability questions for *process model B*

Question	Global	Local	Control Flow	Resource	Information
1	x	x	x		x
2		x	x		
3	x	x	x	x	x
4	x			x	x
5		x	x	x	
6	x	x	x		
7	x			x	x
8		x	x	x	x
9	x		x	x	x
Total	6	6	7	6	6

Each question has a multiple-choice design, where respondents are provided with 5 choices - the last one always being ‘I don’t know’ (i.e. unable to tell). An example question for Process A is given below. For instance, this question is a *local* question that relates to all three perspectives: control-flow (cnt), resource (res), information (inf).

- Q: Who will know that the AB Request is accepted after a positive opinion of the Review Board?*
- a) Only AB Manager*
 - b) Only AB Owner*
 - c) Only Requester*
 - d) Both AB Manager and Requester*
 - e) I don’t know (unable to tell)*

3.6 Dependent Variables

As illustrated in our research model (in Figure 8), we identified four dependent variables concerning process model understandability. Six process model understandability indicators are used in the empirical literature according to results of our systematic literature review. Four of them are used in the research model. The other two indicators are cognitive load and intention to use. We evaluated cognitive load as less reliable than understandability task

effectiveness and understandability task efficiency as it is assessed by subjects. Using the other indicator, intention to use, in the research model would increase the number of perceived understandability questions and also required time to answer these questions. Thus, these two process model understandability indicators are not used in our research model. The first two variables in the research model relate to the (objectively measurable) level of understanding that the participants can demonstrate with respect to each model (Houy et al., 2012; Reijers et al., 2011):

- *Understandability Task Effectiveness* is operationalized by the understandability test score, i.e. the number of correctly answered understandability questions. Counting the number of correct answers in a questionnaire about a process model is regarded as a valid measure for process model understandability (Laue & Gadatsch, 2010).
- *Understandability Task Efficiency* indicates the degree of cognitive resources spent by the reader in understanding the model (Mendling, Strembeck, et al., 2012). It is operationalized by dividing the test score to the total time spent by a participant for the questions that he/she correctly answered. This formulation relies on the thought that a better understanding may be compromised by a faster understanding (Bodart, Patel, Sim, & Weber, 2001). From this perspective, understandability task efficiency should essentially be considered as a productivity measure (Poels, 2011).

The remaining two variables are based on the two constructs of the Technology Acceptance Model (TAM) (Davis, 1989) (i.e. perceived usefulness and perceived ease of use) and concern users' perception of the models in terms of their usefulness for understandability and ease of understanding.

- *Perceived Usefulness for Understandability (PUU)* indicates users' perception on the utility of a process model structured in a particular form in providing gains to the user in terms of understandability.
- *Perceived Ease of Understanding (PEU)* indicates the degree to which a person believes that understanding a model is free from mental effort (as also in Houy et al. (2012)).

TAM and its derivatives (e.g. (Venkatesh, Morris, Davis, & Davis, 2003)) are the commonly referred theories that predict and explain the acceptance and use of design artefacts, such as IS methods and models (Moody, 2003; Recker, Rosemann, Green, & Indulska, 2011). In TAM, the two constructs (perceived usefulness and ease of use) are believed to be strong determinants of users' intentions to use a design artefact. For the experiment, the variables that are adopted are operationalized using multiple indicators (scale items), which have been evaluated for reliability and validity in previous research (Davis, 1989; Moody, 2003). Following (Venkatesh et al., 2003), we used 4 items for each construct, where the wording of the items was modified to accommodate this research. Below are two example items:

- PUU-1: Using this type of process models would make it more easy to communicate business processes to end-users
- PUE-1: I found the way the process is represented as clear and easy to understand.

The participants expressed their level of agreement with each statement on a 7-point Likert scale, ranging from 1 (strongly disagree) to 7 (strongly agree).

3.7 Experiment Blocks

The experiment was designed to have six blocks as shown in Table 7 allowing different combinations of modularity representation and presentation medium. Each participant went through a single block, where he/she was given two process models (A and B) in sequence. In each block, the models were shown using different forms of modularity representation but either on paper or in a computer environment. As subjects are assigned to one of six blocks randomly in each experiment, the experiment design is randomized. We did not use another form of modularity representation of the same process per participant as the results would no longer be reliable due to learning effects. We did not add blocks representing the other presentation medium for a pair of ordered modularity representations e.g. a block containing Repr1 for Process Model A and Repr2 for Process Model B in order as modularity representations and Computer as presentation medium. We evaluated that current six blocks can be counted as representative for all possible combinations.

Table 7 Experimental block-design

Experiment Block	Form of Modularity Representation		Presentation Medium
	Process Model A	Process Model B	
1	Repr1	Repr2	Paper
2	Repr1	Repr3	Computer
3	Repr2	Repr1	Computer
4	Repr2	Repr3	Paper
5	Repr3	Repr1	Paper
6	Repr3	Repr2	Computer

3.8 Questionnaire

The questionnaire for the experiment was provided through an online web environment, which was developed using a software application available for creating online surveys (Sawtooth Software SSI WEB 8.4.6). The questionnaire consisted of 5 parts. The *first* part involved questions related to the personal factors, where participants were asked to give their opinion about their experience and knowledge on process modeling and BPMN, and familiarity with the process and its domain. In the *second* part, the participants were given Process A in a particular form and on a medium depending on the experiment block that they were assigned to. They were expected to answer 9 understandability questions (each placed on a separate online webpage in sequence). In the blocks where computers were used, the process models were embedded in the questionnaire environment in such a way that the question and model were presented on the same page. The *third* part gathers users' perceptions on the particular representation form and medium used to represent the model for Process Model A. The *fourth* and the *fifth* parts of the questionnaire had the same structure as the second and third parts, but this time for Process Model B. The parts of the experiments are shown in brief in Figure 11. There are six variants of each process model as there are three forms for modularity representation and two alternatives for presentation medium. The variant used for one process should not be used for the other process for the same participant. Moreover, the questionnaire contained a tutorial between first part and second part to inform participants about the meaning of BPMN 2.0 symbols used in the

process models. Questionnaire including understandability questions for two processes and complete list of PUU and PEU questions are provided in Appendix D.

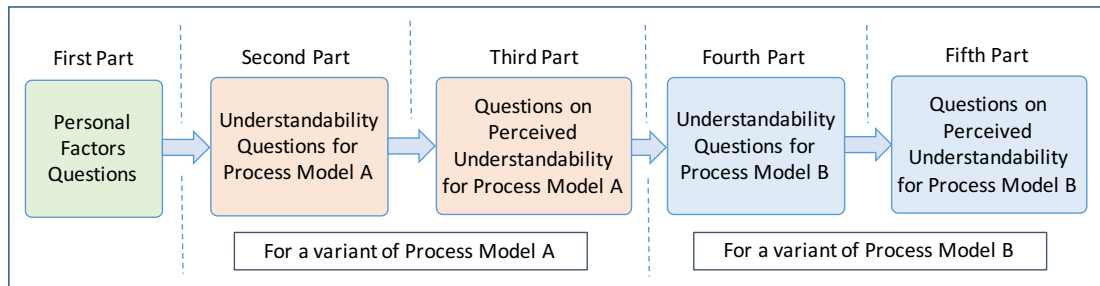

Figure 11 Parts of experiment

All participants (whether they received the models on paper or on computer) received the questions through the *online* environment. This was particularly necessary for accurately tracking the time it took for participants to answer each understandability question, and for computing metrics regarding the *understandability task efficiency*. The participants were informed upfront that they were time-tracked.

Before the actual experiment took place, the questionnaire was pre-tested as a final step by 6 people (4 graduate students, and 2 PhD students). This also gave an indication about the required time-frame for the experiment. As a result of the pre-test, several ambiguities and minor mistakes were corrected in the final version.

3.9 Participants

The first experiment took place in a division in the headquarters of the company from which the process models used in the experiments originate. This experiment took place in *June 2015*. The second experiment was conducted as a part of business process management course at Eindhoven University of Technology, Netherlands in *January 2016*. The third experiment was carried out in *February 2016*. The participants of this last experiment were employees of a national research institute in Turkey which mainly conducts R&D activities in the fields of software technologies and e-government.

In Experiment 1, the company representatives initially selected 74 employees working in 18 departments of the division (where the experiment took place), who had already taken or may potentially take part in the execution of one of these processes. A reminder e-mail was sent to selected employees to encourage participation and emphasize the importance of each individual contribution. Ultimately, 61 employees participated in the experiment, leading to a response rate of around 82%. Each participant was sent an invitation with practical guidelines on accessing the online experiment site, including a username which also determined the experimental block that the participant was assigned to. All participants have at least a university degree - majority with an engineering background. Out of 61, 26 employees (who work at Quality and Regulatory department) had previously taken part in the execution of one of these processes or were moderately familiar with their execution.

Experiment 2 took place in a university setting with the participation of 146 graduate students. The students were enrolled in the master programs of the Department of Industrial Engineering & Innovation Sciences at Eindhoven University of Technology in Netherlands.

They had followed the IBM05 - Business process management course during the period of November 2015 to January 2016. Hence, they had similar theoretical background on process modeling at the time when the experiment took place in January 2016. Participation to the experiment was on voluntary basis; however, the students were offered 0.5 extra points (out of 10) for the same course to provide some level of motivation for participation. Among 208 students, 146 participated.

Experiment 3 was conducted in a national research institute in Turkey with the participation of 55 practitioners, majority of which has expertise on software development. The participation was on voluntary basis. The participants were informed that the results will be treated anonymously and used only for research purposes. Based on appropriate times for the participants, the experiment was conducted in six sessions, which took place between February 24 and March 1, 2016. All participants had university degrees - majority with a bachelor of science in computer engineering and a master of science in computer engineering or information systems.

The participants were randomly assigned to each experiment block with the exception of the 26 employees in Experiment 1 that had certain degree of familiarity with the domain and process models. These were evenly assigned to the blocks (4 or 5 participants per experiment block). Distribution of participants by block for each experiment is depicted in Figure 12.

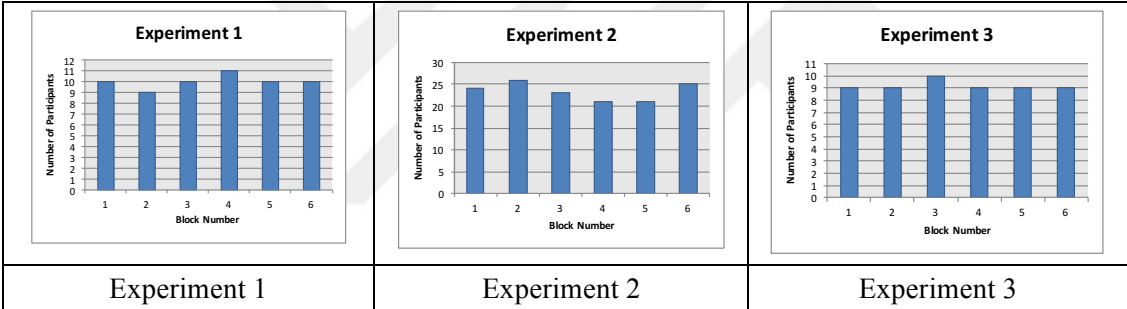

Figure 12 Distributions of participants by block in each experiment

The distribution of participants in all experiments per block can be seen in Figure 13. The minimum block size is 40 and the maximum block size is 44, which shows that the numbers of participants in each block are parallel.

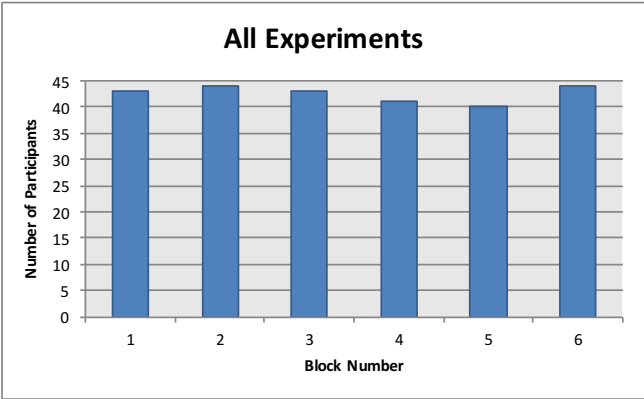

Figure 13 Distribution of participants by block

We expected from the participants to be at least moderately familiar with process models, but we do not require a certain level of BPM expertise. All participants have a certain level of familiarity with process modes, mainly due to their current university education or position in their companies. Overall, data from 60 participants in Experiment 1, 140 participants in Experiment 2 and 55 participants in Experiment 3 are counted as valid. Total number of participants is 255 and sample size is 510 as there are two data rows (corresponding to two processes) per participant. When compared with the number of participants in the experiments reported in the literature (as depicted in Figure 4, page 16), our sample size corresponded to the second highest number of participation.





CHAPTER 4

4 RESULTS AND DISCUSSIONS

This section is structured into five sections. In Section 4.1, we describe the activities performed for data preparation for subsequent statistical analysis. Section 4.2 presents the descriptive statistics regarding the results of the experiments. In Section 4.3, we present the normality tests on the data as a prerequisite for statistical analysis. Section 4.4 presents the results of the hypotheses testing which provides the main input for discussions. The final section in this chapter (4.5) discusses the results.

4.1 Data Preparation and Assumptions

Before we started our statistical analysis, we performed a set of data cleaning and transformation activities. Each data entry submitted by a participant included data for two different forms of modularity representations with the same presentation medium. Thus, each single data entry was split into two entries per participant in the analysis.

We determined rules to detect outliers with respect to the time it took for participants to complete the understandability questions. It is considered that each participant should be able to answer an understandability question in at most 10 minutes (600 seconds) and at minimum in 10 seconds. (We argue that these thresholds are appropriate considering that the average time spent for an understandability question is 107.78 seconds with standard deviation of 39.75 seconds.) In particular, the rules applied for data cleaning based on the time spent for understandability questions are as follows:

1. When the time spent for three or more understandability questions was longer than 600 seconds or shorter than 10 seconds for the same participant, any entry for that participant was regarded as an outlier and removed.
2. If at most two time periods were longer than 600 seconds or less than 10 seconds in a data entry of a participant, these values (that are beyond this band) were transformed into the average of the time periods residing in the same block and same process in that experiment.

Some of the perceived understandability questions were inversed (negated) to help minimize participants' response bias. Both type of questions used the 7 point Likert scale. For practical reasons in statistical analysis, results of negatively stated questions were reversed (i.e. score 1 became 7 and vice versa).

In Experiment 1, the original data set had entries from 61 participants. One participant had only 1 correct answer from a total of 18 questions for two process models. Time spent for questions was considered unrealistic and most questions were answered as "I don't know". Applying the Rule 1 given above, this data entry was determined as an outlier and removed from the data set of that experiment. In Experiment 2, values from 6 participants were in a

similar condition and were removed from the data set. This removal led to a decrease in the total number of participants in Experiment 1 and 2.

Applying the Rule 2 given above, 20 values in the data set of Experiment 1 (17 of them longer than 600 seconds, and 3 shorter than 10 seconds), 49 values in Experiment 2 (40 longer than 600 seconds, and 9 shorter than 10 seconds), and finally 1 value in Experiment 3 were replaced with the average value of time values in the same group (block should be the same with the block of time value to be changed and same process model is used).

We used IBM SPSS Statistics Version 23 in Mac OS X for statistical analyses. As is common in experimental studies, the standard level of significance used in this study is at the level of .05.

4.2 Descriptive Statistics

In this sub-section, we first provide descriptive statistics for participants’ background characteristics (such as their process modeling competencies or familiarity with the process domain) with the related question asked to them. Next, we show the descriptive statistics for dependent variables introduced in Figure 8 for each experiment. Finally, we present the correlation analysis between variables to uncover potential relationships between variables.

4.2.1 Descriptive Statistics for Participants’ Background Characteristics

Figure 14 presents the distributions of participants’ level of expertise with process models in three experiments. In Experiment 1, 75% of the participants worked with process models first more than three years ago where 37% of participants in Experiment 2 worked with process models first more than three years ago, and approximately half of the participants in Experiment 3 first worked with process models more than three years ago. The biggest percentage of participants with at least three years of experience with process models was observed in Experiment 1. To sum up, participants in Experiment 1 seem to have more experience with process models than the participants of other experiments.

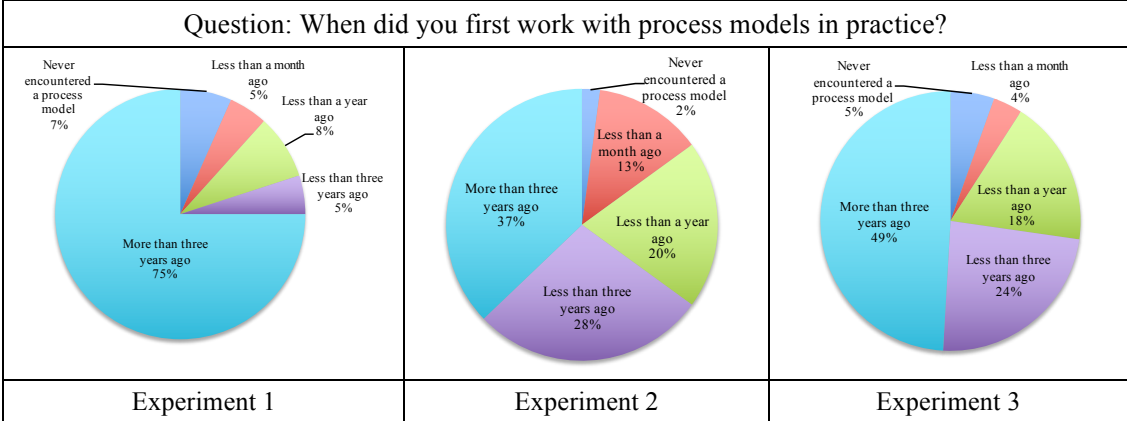

Figure 14 Participants’ level of experience with process models

Figure 15 shows the distributions of participants in three experiments based on their opinion about how frequently they encounter process models in practice. Around half of the participants in all experiments encountered process models less than once a month. The majority of the rest encountered process models more than once a month. The values show

that competencies of participants in terms of the rate of encountering process models were similar among the participants of experiments.

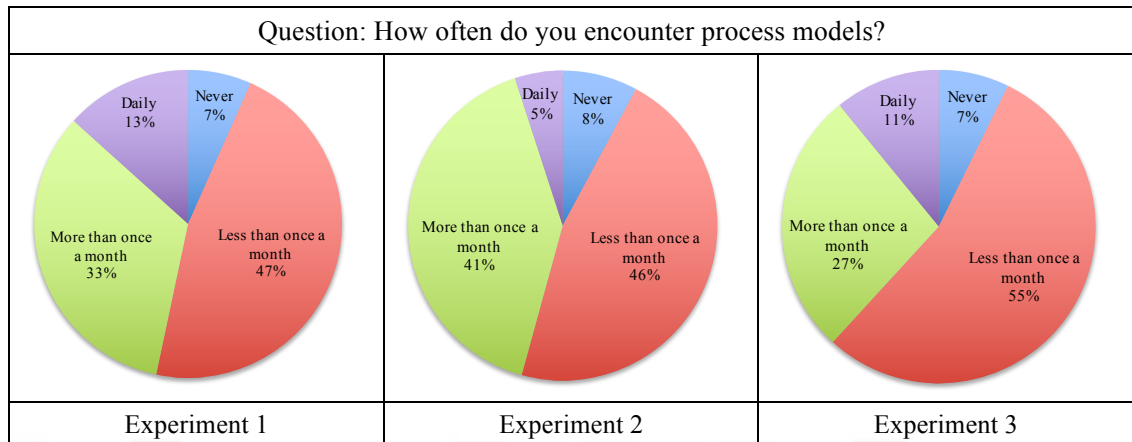

Figure 15 Participants' rate of encountering process models in practice

Figure 16 presents the distributions of participants' familiarity with the process domain in three experiments. The percentage of participants who are not all familiar with the domain are 3%, 30% and 25% in Experiment 1, Experiment 2 and Experiment 3 respectively. A vast majority of participants in Experiment 1 stated that they are at least slightly familiar or more familiar with the process domain. This is expected as the processes used in the experiments were being performed in the organization of participants of Experiment 1. It can be concluded that participants in Experiment 1 have more familiarity with the process domain than other participants and participants in Experiment 2 and participants in Experiment 3 have a similar level of familiarity with the domain.

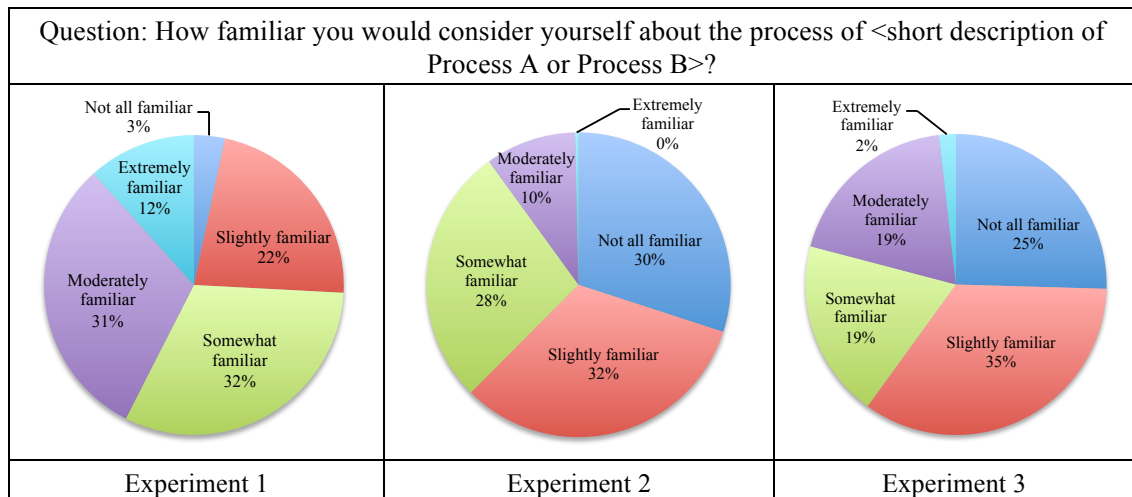

Figure 16 Participants' level of domain familiarity

In Figure 17, the distributions of participants based on their opinion about what their level of knowledge on business process modeling in three experiments are given. In Experiment 1, 87% of participants stated that they were very knowledgeable, knowledgeable or somewhat knowledgeable about process modeling. The sum of percentages of the same categories are 99% in Experiment 2 and 84% in Experiment 3. The values indicate that participants in

Experiment 2 might have slightly more expertise in business process modeling than the participants in Experiment 1 and 3. This might be due to the fact that Experiment 2 took place in a university setting among graduate students attending a business process management course.

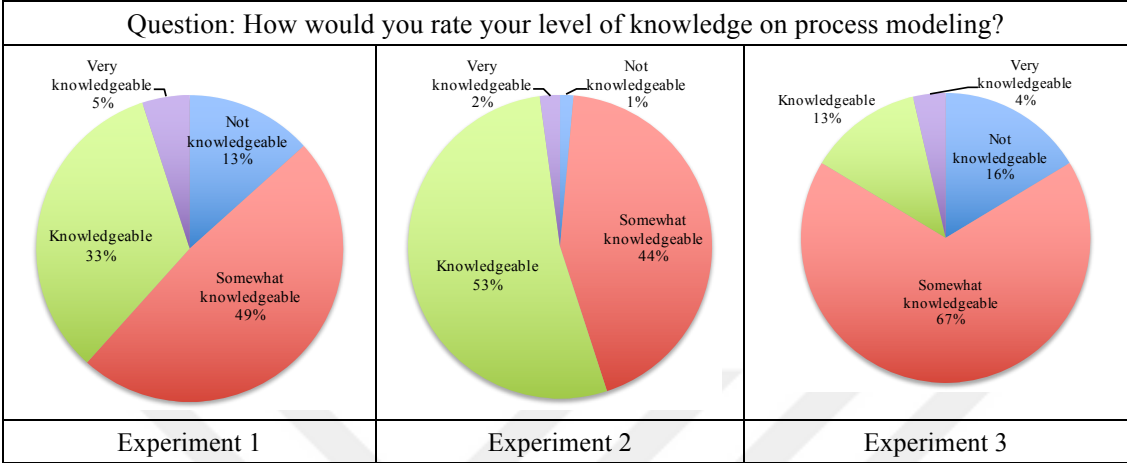

Figure 17 Participants' level of knowledge on process modeling

The distributions of participants in three experiments based on their opinion about their level of knowledge on BPMN 2.0 are given in Figure 18. Participants in Experiment 1 have no or limited knowledge about BPMN. Only 15% of participants reported that they have at least limited knowledge in Experiment 1. 88% and 49% of participants respectively in Experiment 2 and Experiment 3 stated that they have at least limited knowledge about BPMN. These three levels of expertise are far away from each other. It shows that there are considerable differences between the level of knowledge on BPMN 2.0 of participants in different experiments. A large majority of participants in Experiment 2 are at least somewhat knowledgeable about BPMN 2.0.

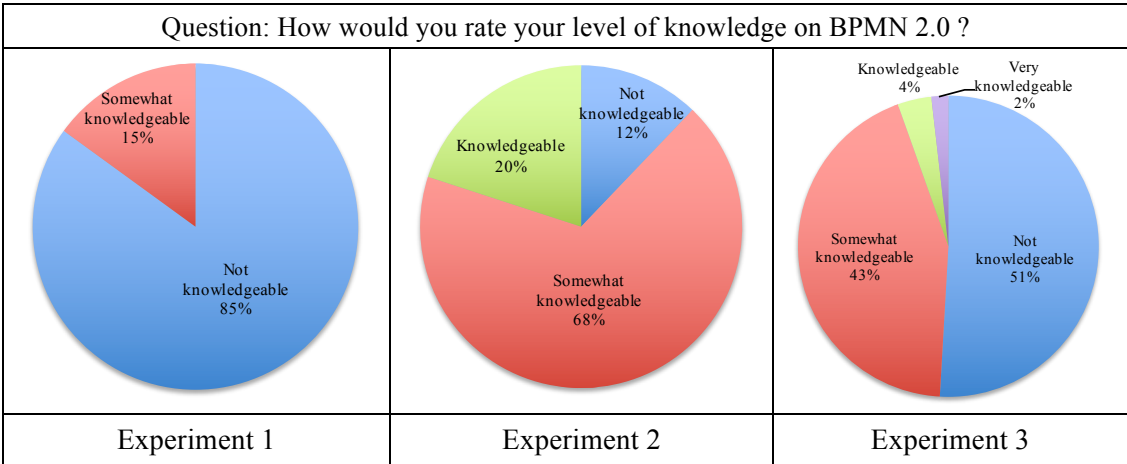

Figure 18 Participants' level of knowledge on BPMN 2.0

In the overall, we can consider majority of Experiment 1 participants to be fairly novice in terms of general BPM skills and capabilities, but to have higher levels of familiarity with the

process domain. It appears that participants of Experiment 2 have the most expertise in BPM skills and capabilities.

4.2.2 Descriptive Statistics for Dependent Variables

This sub-section presents descriptive statistics such as mean, standard deviation (SD) and coefficient of variation (CV) for dependent variables. The descriptive statistics for each dependent variable of the research design is presented in a single table (Table 8 to Table 11). The structure and content of tables are similar and as follows. In the first column (Level column), three levels of first independent variable (modularity representation) and two levels of the second independent variable (presentation medium) are given. In the following columns, descriptive statistics for three experiments are organized. For each experiment, sample size (N), mean, SD and CV are provided for each level. The mean is the preferred measure of central tendency. SD is the average distance of each value away from the sample mean. The larger the standard deviation, the farther away the values are from the mean; the smaller the standard deviation the closer, the values are to the mean. CV is a standardized measure of dispersion of a frequency distribution and is calculated as the ratio of the standard deviation to the mean. CV is dimensionless and has no units. Thus, it is useful to compare different variables in terms of CV. As each participant tested two process models in different forms, Experiment 1 led to 120 observations, Experiment 2 led to 280 observations and Experiment 3 led to 110 observations which are distributed largely in a uniform way over different modularity representations and presentation mediums.

We used boxplots to represent differences among groups. Thick horizontal line in a boxplot shows minimum and maximum values as well as lower quartile (Q1 - 25th percentile), middle quartile (Q2) and upper quartile (Q3 - 75th percentile). Boxplot graphs for each dependent variable in the research design over the independent variables, modularity representation and presentation medium are provided. Boxplots for each dependent variable over modularity representation are given in the first rows and boxplots for that dependent variable over presentation medium are given in the second rows of figures containing boxplot graphs.

Table 8 presents the descriptive statistics for the first dependent variable, *understandability task effectiveness*. Understandability task effectiveness is measured by score which corresponds to the number of correctly answered understandability questions. As each correctly answered question counts for 1 point for the understandability test score and there are 9 understandability questions for each process model, understandability task effectiveness can be between 0 and 9. In Experiment 1, the largest mean ($M = 6.18$, $SD = 1.50$) was obtained with Repr1 among different forms of modularity representation. In Experiment 2, the largest mean ($M = 5.34$, $SD = 1.50$) was again obtained again with Repr1. This changes in Experiment 3. The largest mean ($M = 5.33$, $SD = 2.07$) was achieved with Repr3 in Experiment 3. In all experiments, the distribution with Repr3 has higher dispersions than the distributions with Repr1 or Repr2. The mean for understandability task effectiveness when paper format is used was found to be higher than the mean when computer format is used in all experiments. Experiment 3 group has higher CV values than Experiment 2 group and Experiment 2 group has higher CV values than Experiment 1 generally.

Table 8 Descriptive statistics - understandability task effectiveness

Level	Experiment 1				Experiment 2				Experiment 3			
	N	\bar{X}	SD	CV	N	\bar{X}	SD	CV	N	\bar{X}	SD	CV
Repr1	39	6.18	1.50	0.24	94	5.34	1.50	0.28	37	5.16	1.87	0.36
Repr2	41	5.90	1.51	0.26	93	5.29	1.63	0.31	37	5.16	1.57	0.30
Repr3	40	5.25	1.57	0.30	93	5.14	1.65	0.32	36	5.33	2.07	0.39
Computer	58	5.57	1.61	0.29	148	5.11	1.55	0.30	56	5.14	1.78	0.35
Paper	62	5.97	1.50	0.25	132	5.42	1.62	0.30	54	5.30	1.89	0.36

The boxplot graphs for understandability task effectiveness over the independent variables modularity representation and presentation medium in three experiments are shown in Figure 19.

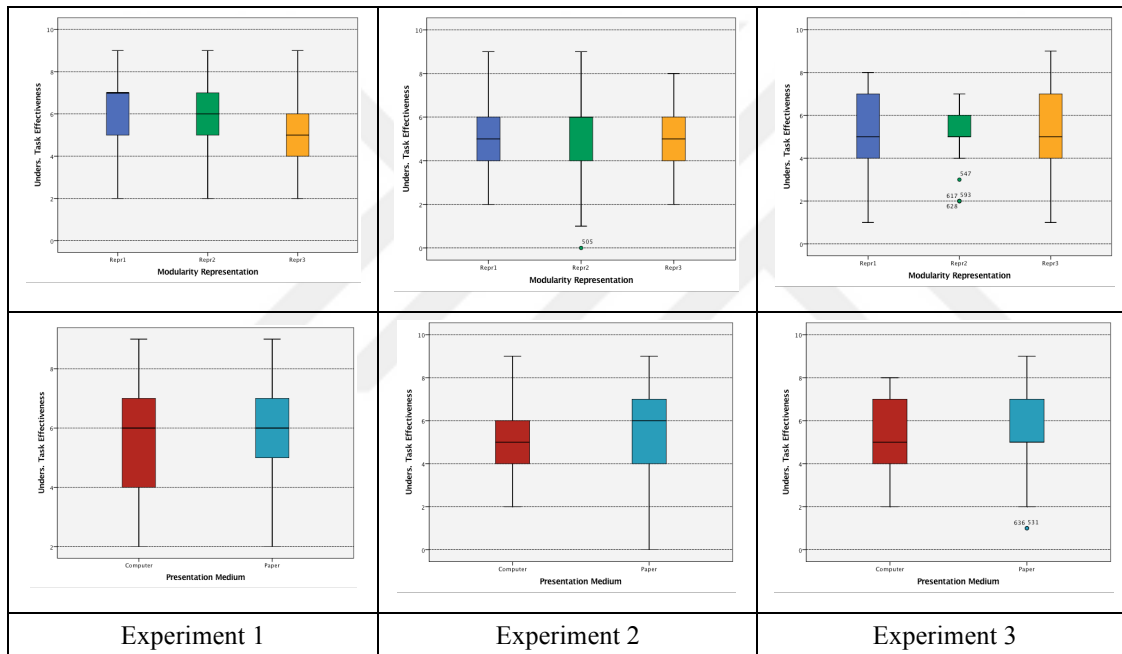

Figure 19 Boxplot graphs for understandability task effectiveness

The descriptive statistics displayed in Table 9 provide the means, SDs and CVs for *understandability task efficiency* for each experiment. (Understandability task efficiency is calculated as number of correctly answered questions divided by the time spent for answering those questions where unit of time spent is hours.) In Experiment 1, it has the highest mean ($M = 40.46$, $SD = 24.94$) among different forms of modularity representation when Repr3 is used. Differently, in Experiment 2 and Experiment 3 the highest means respectively ($M = 49.21$, $SD = 21.15$) and ($M = 39.75$, $SD = 13.28$) are observed when modularity representation is Repr1. Higher understandability task efficiency results were obtained with paper format in Experiment 1 and Experiment 2. On the other hand, in Experiment 3 the mean for understandability task efficiency ($M = 38.66$, $SD = 15.09$) when computer format is used is slightly better than the mean ($M = 36.54$, $SD = 10.74$) when paper format is used.

Table 9 Descriptive statistics - understandability task efficiency

Level	Experiment 1				Experiment 2				Experiment 3			
	N	\bar{X}	SD	CV	N	\bar{X}	SD	CV	N	\bar{X}	SD	CV
Repr1	39	33.18	21.29	.64	94	49.21	21.15	.43	37	39.75	13.28	.33
Repr2	41	33.13	12.86	.39	93	45.02	13.20	.29	37	38.43	14.70	.38
Repr3	40	40.46	24.94	.62	93	48.48	22.61	.47	36	34.59	10.84	.31
Computer	58	32.59	14.93	.46	148	45.89	15.00	.33	56	38.66	15.09	.39
Paper	62	38.39	24.23	.63	132	49.46	23.39	.47	54	36.54	10.74	.29

The boxplots for *understandability task efficiency* over the independent variables modularity representation and presentation medium in three experiments are shown in Figure 20.

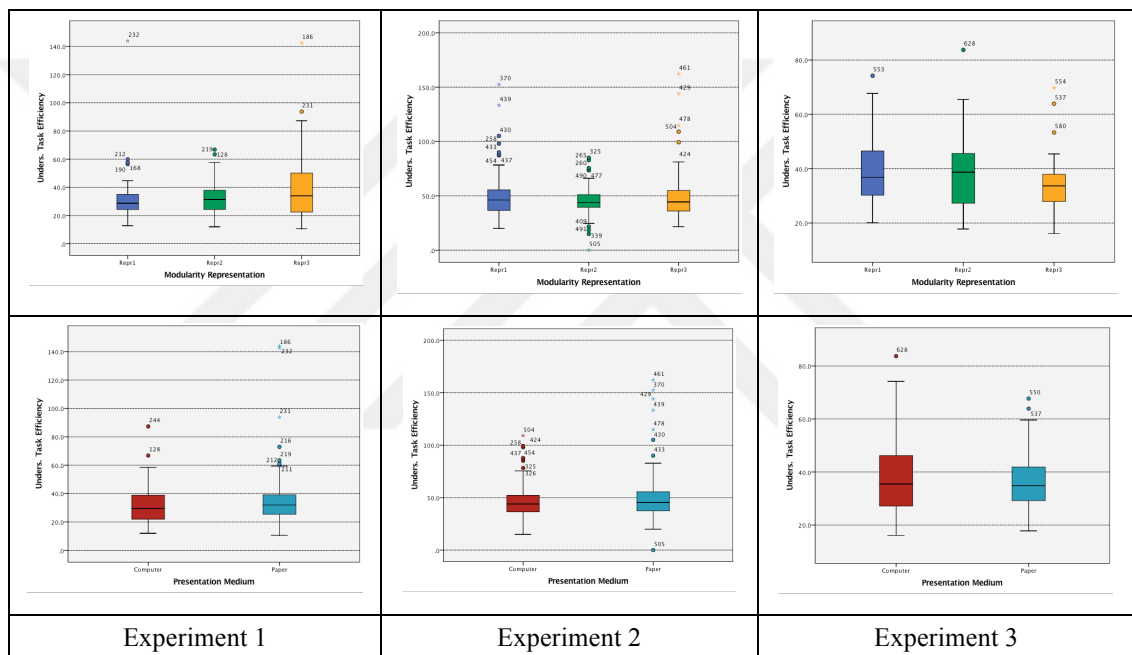

Figure 20 Boxplot graphs for understandability task efficiency

The descriptive statistics for the variable *perceived usefulness for understandability* are shown in Table 10. As there are four items to be answered in a 7-point Likert scale, the minimum value for perceived usefulness for understandability can be 4 and maximum value can be 28. In Experiment 1, the largest mean ($M = 20.67$, $SD = 5.19$) was obtained with Repr1 among different forms of modularity representation. In Experiment 2 and Experiment 3, the mean values for different forms of modularity representation are close to each other. In Experiment 2, the largest mean ($M = 18.99$, $SD = 5.52$) is achieved with Repr2 and in Experiment 3, it ($M = 19.11$, $SD = 4.29$) is achieved with Repr1 with minor differences. The mean for perceived usefulness for understandability when paper format is used is found to be higher than the mean when computer format is used in all experiments.

Table 10 Descriptive statistics - perceived usefulness for understandability

Level	Experiment 1				Experiment 2				Experiment 3			
	N	\bar{X}	SD	CV	N	\bar{X}	SD	CV	N	\bar{X}	SD	CV
Repr1	39	20.67	5.59	0.27	94	18.81	4.97	0.26	37	19.11	4.29	0.23
Repr2	41	18.27	6.01	0.33	93	18.99	5.52	0.29	37	18.97	5.07	0.27
Repr3	40	15.80	6.16	0.39	93	18.97	4.77	0.25	36	18.86	5.21	0.28
Computer	58	16.29	6.45	0.40	148	18.00	5.64	0.31	56	18.20	5.14	0.28
Paper	62	20.03	5.42	0.27	132	19.95	4.15	0.21	54	19.80	4.38	0.22

The boxplots for *perceived usefulness for understandability* over the independent variables modularity representation and presentation medium in three experiments are shown in Figure 21.

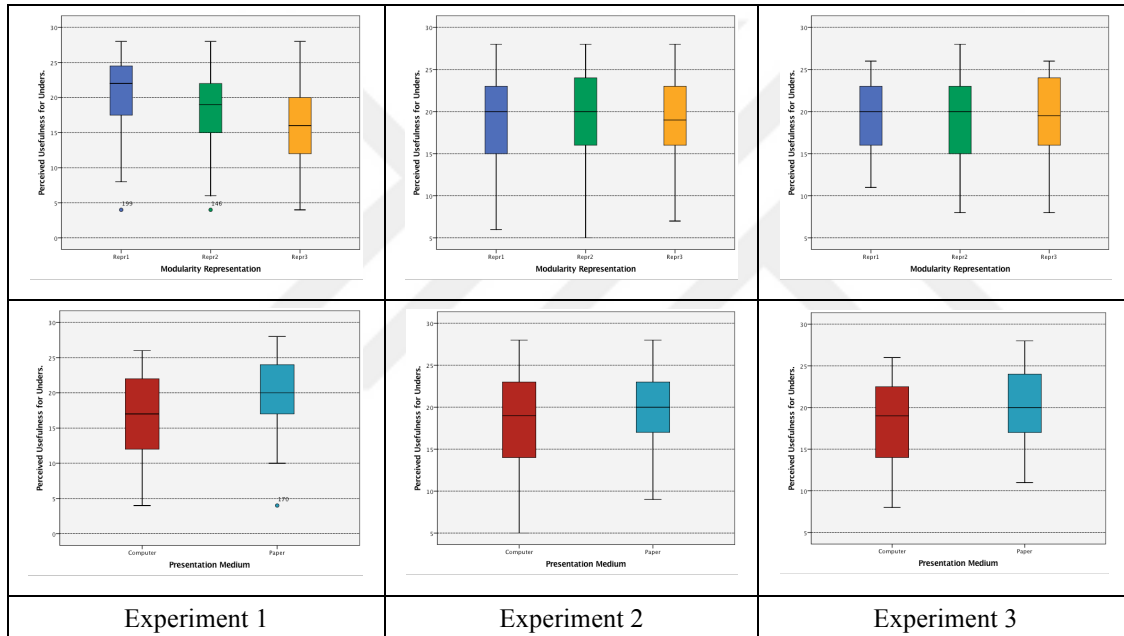

Figure 21 Boxplot graphs for perceived usefulness for understandability

The descriptive statistics for *perceived ease of understanding* are presented in Table 11. The scale for this variable is the same for the variable perceived usefulness for understandability discussed above (i.e. minimum value can be 4, and maximum value can be 28). In Experiment 1, the largest mean ($M = 23.15$, $SD = 5.07$) which is comparatively a high value is obtained with Repr1 among different forms of modularity representation. The largest mean ($M = 20.19$, $SD = 4.64$) is achieved with Repr2 with a very small difference in Experiment 2. The mean for perceived ease of understanding when paper format is used is found to be higher than the mean when computer format is used in three experiments. The findings show similarity with the findings discussed as a result of descriptive statistics of perceived usefulness for understandability shown in Table 10.

Table 11 Descriptive statistics - perceived ease of understanding

Level	Experiment 1				Experiment 2				Experiment 3			
	N	\bar{X}	SD	CV	N	\bar{X}	SD	CV	N	\bar{X}	SD	CV
Repr1	39	23.15	5.07	.22	94	20.18	4.31	.21	37	20.46	4.05	.20
Repr2	41	20.10	5.59	.28	93	20.19	4.64	.23	37	19.41	4.71	.24
Repr3	40	18.63	6.30	.34	93	19.30	4.60	.24	36	19.67	4.54	.23
Computer	58	19.55	5.94	.30	148	19.20	4.88	.25	56	19.66	4.71	.24
Paper	62	21.58	5.82	.27	132	20.67	3.96	.19	54	20.04	4.14	.21

The boxplots for the dependent variable *perceived ease of understanding* over the independent variables modularity representation and presentation medium in three experiments are shown in Figure 22.

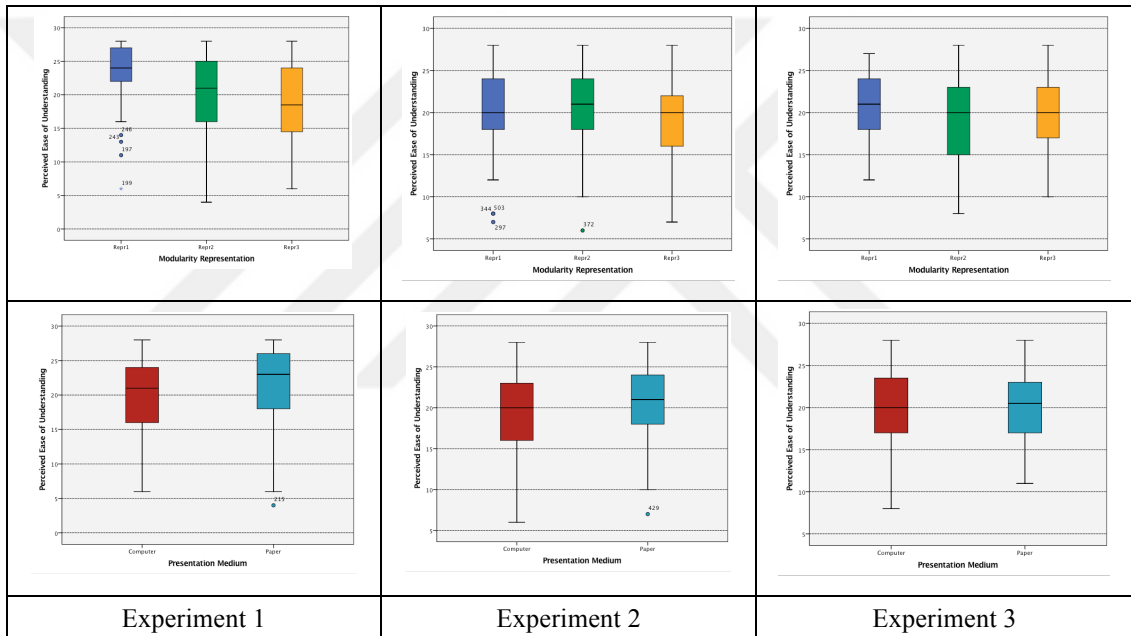

Figure 22 Boxplot graphs for perceived ease of understanding

4.2.3 Correlation Analysis

In the ideal situation, the factors (predictors) are uncorrelated with each other, so that they are able to measure different constructs and are able to predict different parts of the variance on the dependent variable(s). In practice, predictors will be correlated to some degree. Having low correlations among themselves would be strongly preferable (Pituch, Whittaker, & Stevens, 2007).

The calculation of Spearman’s correlation coefficient requires the data to be interval, ratio level or ordinal. Since nominal data is not accepted, two variables, modularity representation and presentation medium are not included in the correlation analysis. A correlation matrix examining the relationships between the variables is displayed in Table 12. Sample size is 510 except for the last row (the row indicating correlation analysis of theoretical knowledge on process modeling and BPMN 2.0 with other factors) in Table 12 where sample size

decreases to 390. If the p-value is less than .05, there is a significant correlation between two variables. In the correlation matrix, significance values which are less than .05 are also less than .01 level.

The correlation coefficient is a descriptive statistic that measures the strength of the linear relationship between two variables. The value of the correlation coefficient, symbolized as r_s , ranges from -1 (for a perfect negative correlation) to +1 (for a perfect positive correlation). We can describe the strength of the correlation using the following classification for r_s : .00 - .19: very weak, .20 - .39: weak, .40 - .59: moderate, .60 - .79: strong, .80 - 1.00: very strong. According to this classification, strongest correlations appear to be moderate correlations between *BP modeling knowledge* and *intensity of working with process models*, $r_s = .424$, $p = .000$ and between *BP modeling knowledge* and *BPMN 2.0 knowledge*, $r_s = .396$, $p = .000$. Moreover, it is observed that the most correlated variable is *BP modeling knowledge* (correlated with five variables) whereas the least correlated variable is *theoretical knowledge on BP modeling and BPMN 2.0* (correlated with two variables).

Table 12 Correlation matrix between external variables

Variable	Experience with process models	Intensity of working with process models	Familiarity with the process domain	BP modeling knowledge	BPMN 2.0 knowledge	Theoretical knowledge on BP modeling and BPMN 2.0
Experience with process models	1.000					
Intensity of working with process models	.273**	1.000				
Familiarity with the process domain	.243**	.206**	1.000			
BP modeling knowledge	.232**	.424**	.174**	1.000		
BPMN 2.0 knowledge	-.082	.203**	-.023	.396**	1.000	
Theoretical knowledge on BP modeling and BPMN 2.0	-.072	.068	.096	.280**	.275**	1.000

** . Correlation is significant at the .01 level (2-tailed).

It is expected to have correlations between the measures used to operationalize a factor. Expertise with business process models, specified in Figure 8, is operationalized by two variables, *experience with process models* and *intensity of working with process models*. It can be seen from the correlation matrix that there is correlation between two variables. Another factor, BPM competencies, is operationalized by three variables which are *BP modeling knowledge*, *BPMN 2.0 knowledge* and *theoretical knowledge on BP modeling and BPMN 2.0*. Since we mainly examine the effect of factors, having correlation between all pairs of these three variables does not threaten our results.

4.3 Checking Assumptions of the Statistical Tests

Before testing our hypotheses, we first analyzed the data for conformance with the assumptions of the statistical tests that can be used. The use of parametric tests requires that the data be normally distributed, have homogeneity of variance and be continuous (Field, 2013). Each dependent variable in the experiment design and other dependent variables derived from distribution of understandability questions according to different process scope and process perspectives were analyzed in terms of normality.

Two well-known tests of normality, Kolmogorov-Smirnov (K-S) and Shapiro-Wilk (S-W) tests, can be used to test the hypothesis that distribution of the data is normal. For both tests, if $p < .05$, then the null hypothesis H_0 (the data is normally distributed) is rejected which means that the distribution in question is significantly different from a normal distribution. As the sample size increases, these normality tests become more sensitive to even minor deviations in normality. In large samples, these tests can be significant even when the scores are slightly different from a normal distribution. Thus, they should always be interpreted in conjunction with visual inspection of graphs like histograms, P-P or Q-Q plots (Field, 2013). Histogram allows to visualize the distribution of the data and it gives the rough idea of whether or not the data follows the assumption of normality. When a histogram's shape approximates a bell-curve it suggests that the data may have come from a normal distribution. Q-Q plots (normal Q-Q plot and detrended normal Q-Q plot) are also used to test the assumption of normality by researchers. If the data is approximately normally distributed, the points will be on or close to the reference line in normal Q-Q plot and cases in the detrended normal Q-Q plot should cluster around the horizontal 0 line. A boxplot gives a look at the outliers and the location of quantiles. It shows if there are outliers in the data. Outliers show the violation of the assumption of normality. Boxplots can be useful for testing for symmetry. If a variable is normally distributed, its 25 and 75 percentiles are symmetric.

The rule of thumb says that for data sets larger than 50 samples K-S test is used. The S-W Test is more appropriate for small sample sizes (< 50 samples). Since data set has more than 50 samples, K-S test is preferred. The following procedure is applied to test the assumption of normality. The first step in examining the data for normality is the K-S test. A sufficiently small p-value implies but does not prove that the data is not normally distributed. Second step is to evaluate histogram. If K-S test result and histogram both indicate that the distribution of the data is normal, other steps are not followed. If K-S test result does not determine a normal distribution, histogram, normal Q-Q plot, detrended normal Q-Q plot and boxplot are analyzed. When all of these graphs give an indication of normality, the distribution is assumed to be normal. Otherwise, the distribution is non-normal.

Table 13 presents the normality test results for 26 dependent variables. The first 12 dependent variables (No. 1 to No. 12) are related to effectiveness and the second 12 dependent variables (No. 13 to No. 24) are related to efficiency. 22 of 26 dependent variables (No. 2 to No. 12 and No. 14 to No. 24) originated from the division of understandability questions according to process scope and process perspective. The figures referenced in Table 13 consist of five parts:

- K-S normality test result,
- Histogram,
- Normal Q-Q plot,

- Detrended normal Q-Q plot and
- Boxplot.

The K-S tests of normality for dependent variables determine that the data do not fit the requirements of a normal distribution (all with $p = .000$). So, the graphs given in figures were analyzed. When the procedure defined for testing normality was applied, analysis results showed that the population is normally distributed for five dependent variables including understandability task effectiveness, understandability task effectiveness (local), understandability task effectiveness (global), understandability task effectiveness (control flow) and understandability task effectiveness (resource) and there are clear deviations from normality for the other dependent variables.



Table 13 Normality test results

No	Dependent Variable	Distribution	Reference
1	Und. Task Effectiveness	Normal Dist.	Figure 23, Appendix E
2	Und. Task Effectiveness (Local)	Normal Dist.	Figure 24, Appendix E
3	Und. Task Effectiveness (Global)	Normal Dist.	Figure 25, Appendix E
4	Und. Task Effectiveness (Local-Only)	Non-Normal Dist.	Figure 26, Appendix E
5	Und. Task Effectiveness (Global-Only)	Non-Normal Dist.	Figure 27, Appendix E
6	Und. Task Effectiveness (Global and Local)	Non-Normal Dist.	Figure 28, Appendix E
7	Und. Task Effectiveness (Control Flow)	Normal Dist.	Figure 29, Appendix E
8	Und. Task Effectiveness (Resource)	Normal Dist.	Figure 30, Appendix E
9	Und. Task Effectiveness (Information Flow)	Non-Normal Dist.	Figure 31, Appendix E
10	Und. Task Effectiveness (Control Flow-Only)	Non-Normal Dist.	Figure 32, Appendix E
11	Und. Task Effectiveness (Resource and Information Flow-Only)	Non-Normal Dist.	Figure 33, Appendix E
12	Und. Task Effectiveness (Control Flow, Resource and Information Flow)	Non-Normal Dist.	Figure 34, Appendix E
13	Und. Task Efficiency	Non-Normal Dist.	Figure 35, Appendix E
14	Und. Task Efficiency (Local)	Non-Normal Dist.	Figure 36, Appendix E
15	Und. Task Efficiency (Global)	Non-Normal Dist.	Figure 37, Appendix E
16	Und. Task Efficiency (Local-Only)	Non-Normal Dist.	Figure 38, Appendix E
17	Und. Task Efficiency (Global-Only)	Non-Normal Dist.	Figure 39, Appendix E
18	Und. Task Efficiency (Global and Local)	Non-Normal Dist.	Figure 40, Appendix E
19	Und. Task Efficiency (Control Flow)	Non-Normal Dist.	Figure 41, Appendix E
20	Und. Task Efficiency (Resource)	Non-Normal Dist.	Figure 42, Appendix E
21	Und. Task Efficiency (Information Flow)	Non-Normal Dist.	Figure 43, Appendix E
22	Und. Task Efficiency (Control Flow-Only)	Non-Normal Dist.	Figure 44, Appendix E
23	Und. Task Efficiency (Resource and Information Flow-Only)	Non-Normal Dist.	Figure 45, Appendix E
24	Und. Task Efficiency (Control Flow, Resource and Information Flow)	Non-Normal Dist.	Figure 46, Appendix E
25	Perceived Usefulness for Understandability	Non-Normal Dist.	Figure 47, Appendix E
26	Perceived Ease of Understanding	Non-Normal Dist.	Figure 48, Appendix E

Totally, five of dependent variables were found to have normal distribution and rest of them have non-normal distribution. As only a few of the all dependent variables have a normal-distribution, we preferred to use *non-parametric tests* for analyzing data and forewent the predictive power of *parametric tests*.

4.4 Hypotheses Testing

We set out nine hypotheses about the influence of process model and personal factors on understanding of business process models. We tested the formulated research hypotheses

using the *non-parametric test of Kruskal-Wallis* (with all pairwise and in some cases additionally stepwise step-down) for the data collected in the family of experiments. Results of investigation are presented according to hypotheses. Table 14 shows the results of our tests regarding the set of groups of hypotheses from H1 to H8.

Table 14 Results of the Kruskal-Wallis statistical tests

H.	Variable	Understandability task effectiveness		Understandability task efficiency		Perceived usefulness for understandability		Perceived ease of understanding	
		H	p	H	p	H	p	H	p
H1	Modularity representation	2.959	.228	.052	.974	3.419	.181	10.118	.006*
H2	Presentation medium	5.522	.019*	.196	.658	17.612	.000*	9.316	.002*
H3	Experience with process models	7.210	.125	7.505	.111	.935	.919	1.674	.795
H4	Intensity of working with process models	.815	.846	11.079	.011*	3.666	.300	10.295	.016*
H5	Domain familiarity	2.926	.570	5.469	.242	3.972	.410	3.994	.407
H6	BP modeling knowledge	2.871	.412	10.286	.016*	1.223	.748	4.556	.207
H7	BPMN 2.0 knowledge	4.061	.255	39.461	.000*	5.619	.132	11.454	.010*
H8	Theoretical knowledge on BP modeling and BPMN 2.0	16.354	.003*	2.479	.648	5.544	.236	1.498	.827

* Correlation is significant at the .05 level (2-tailed).

Hypotheses through H1 to H8 are tested in the following sub-sections where a group of hypotheses are examined in each sub-section. Effect of distribution of understandability questions according to process scope and perspective is further analyzed in Section 4.4.1 where the influence of modularity representation is investigated.

4.4.1 Testing the Hypotheses on the Forms of Modularity Representation

We argued in our first group of hypotheses that different forms of modularity representation in BPMN significantly influences process understandability. Table 14 shows the results of our tests regarding set of hypotheses in H1.

Understandability Task Effectiveness. The results of the Kruskal-Wallis tests indicate that the understandability task effectiveness measured by the score achieved from understandability questions is not influenced by the modularity representation, $H(2) = 2.959$, $p = .228$ (Table 36, Appendix F). We performed further tests to investigate if the scores

obtained from questions regarding different *process scope* (global / local) and *perspectives* (control flow / resource / information) show any major difference. The results show that some scores concerning different process scope and perspectives differ significantly. According to results of Kruskal-Wallis tests, three of the dependent variables which regard different subsets of understandability questions are significantly affected by forms of modularity representation (Table 37, Appendix F).

First, the scores from *local* questions (which involve information about sub-processes) are significantly higher in Repr1 and Repr2 than in Repr3, $H(2) = 6.146$, $p = .046$ (Figure 49, Appendix F) according to stepwise comparisons using the Kruskal-Wallis test (Table 38, Appendix F). Stepwise comparisons were applied as pairwise comparisons could not find a significant difference for this relationship (Figure 50, Appendix F). Second, the influence of using different forms of modularity representation on understandability task effectiveness related to score from *local-only* questions (which involve information about only sub-processes and are not interested in the main model) is found to be significant, $H(2) = 11.572$, $p = .003$ (Figure 51, Appendix F). Pairwise comparisons using the Kruskal-Wallis test revealed that there are significant differences between Repr2 and Repr3 ($p = .018$) and between Repr1 and Repr3 ($p = .006$) (Figure 52, Appendix F). For the *global* questions (where answering requires information about the main/modularized model), *global-only* questions (where answering requires information only about the main model) and *global-local* questions (where answering requires information about both main model and one or more sub-processes), the differences in the scores for each form of modularity representation are not significant ($p = .865$, $p = .238$ and $p = .824$ respectively) (Table 37, Appendix F). Third and finally, the influence of using different forms of modularity representation on task effectiveness score calculated from *control flow-only* questions (which involve information about only control flow perspective and do not involve information about resource and information flow perspectives) is found to be significant, $H(2) = 8.429$, $p = .015$ (Figure 53, Appendix F). Pairwise comparisons using the Kruskal-Wallis test revealed that there are significant differences between Repr2 and Repr3 ($p = .042$) and between Repr1 and Repr3 ($p = .030$) (Figure 54, Appendix F). For the other perspectives such as *resource* or *information* and combination of these perspectives, the differences in the scores for forms of modularity representation are not significant (Table 37, Appendix F).

To summarize results for H1a,

- participants given Repr2 (flattened process model with the use of groups) as the form of modularity representation obtained significantly higher task effectiveness results than participants given Repr3 (process models where sub-processes are used) regarding *local*, *local-only* and *control flow-only* questions,
- participants given Repr1 (flattened process model without the use of groups) as the form of modularity representation obtained significantly higher task effectiveness results than participants given Repr3 (process models where sub-processes are used) regarding *local*, *local-only* and *control flow-only* questions.

Based on these results, we can infer that for *local* and *local-only* questions, modularization degrades effectiveness when *overview+detail* strategy is used (as in Repr3, where sub-processes are shown separately, detached from their context). This is likely due to the increased browsing costs (split-attention effect) in Repr3 and *insignificant* cost of complexity in flattened models (Repr1) even with the group information (Repr2). This may

further indicate that the context -where a sub-process takes place, plays an important role in understanding (sub-)process information. On the other hand, the use of modularization in which the sub-processes are displayed directly within the context of the higher level model (as in Repr2) doesn't offer any advantage for effectiveness.

For *global*, *global-only* and *global-local* questions, the modularization does not have significant effect on effectiveness. This implies that the understandability gain acquired in abstracting away less relevant information through modularization is insignificant in these types of process models.

Understandability Task Efficiency. The influence of using different forms of modularity representation on understandability task efficiency was analyzed. Although the average understandability task efficiency (i.e. the number of correctly answered questions divided by the time spent for answering them) is slightly higher for Repr3 (mean values are 43.47, 40.74 and 43.62 for Repr1, Repr2 and Repr3, respectively), our statistical analysis does not indicate a significant difference for the three forms of modularity representations, $H(2) = .052$, $p = .974$ (Table 36, Appendix F). A relatively high dispersion of the efficiency values for Repr3 (standard deviations are 20.77, 14.29 and 21.95 for Repr1, Repr2 and Repr3, respectively) is also worth mentioning. The results are in line also with respect to the efficiency values obtained for questions concerning different process scopes and perspectives (i.e. there is no significant difference with respect to the forms of modularity representation) (Table 39, Appendix F).

Perceived Usefulness for Understandability. Participants' view on the usefulness of three modularity representation forms does not differ significantly, $H(2) = 3.419$, $p = .181$ (Table 36, Appendix F). The mean value of perceived usefulness for understandability for Repr1 ($M = 19.30$, $SD = 5.01$) is higher than the mean value for Repr 2 ($M = 18.81$, $SD = 5.53$) and the mean value of perceived usefulness for understandability for Repr2 ($M = 18.81$, $SD = 5.53$) is higher than the mean value for Repr 3 ($M = 18.20$, $SD = 5.36$).

Perceived Ease of Understanding. Different from usefulness, the attitude on the ease of understanding differs significantly with respect to the forms of modularity representation, $H(2) = 10.118$, $p = .006$ (Table 36 and Figure 55, Appendix F). According to pairwise comparisons with adjusted p-values, there is a significant difference only between Repr1 and Repr3 ($p = .004$) (Figure 56, Appendix F). Participants given Repr1 as the form of modularity representation significantly have better perceived ease of understanding results than participants given Repr3. Repr1 is considered easier to understand than both modular forms, i.e. Repr2 and Repr3. This indicates that, fully flattened models are regarded as easier to understand than any of their modularized form. Given that the only difference between Repr1 and Repr2 is the grouping information, we can deduce that any additional information on the process model can be perceived to increase the difficulty of understanding.

4.4.2 Testing the Hypotheses on the Presentation Medium

The second group of hypotheses, H2, argued for the influence of the medium used to present process models on the understandability. The results of the tests regarding this set of hypotheses are shown in Table 14. The results indicate that the presentation medium has a significant effect on the understandability task effectiveness but does not have a significant effect on the understandability task efficiency. Moreover, it is regarded as critical from users' point of view. Totally, three understandability variables are significantly affected by

presentation medium (Table 40, Appendix G). There is no need for post-hoc analysis as we have two groups.

Understandability Task Effectiveness. The effect of presentation medium on understandability task effectiveness ($H(1) = 5.522, p = .019$) is found to be significant (Figure 57, Appendix G). The use of paper as a presentation medium created more understandable process models than the use of computer in terms of task effectiveness.

Understandability Task Efficiency. The statistical tests indicate that the use of paper or computer for presenting process models does not lead to a significant difference on the understandability task efficiency (Table 40, Appendix G).

Perceived Usefulness for Understandability and Perceived Ease of Understanding. The participants consider models presented on paper more useful and easier to understand (from understandability's point of view) than the ones presented on the computer, $H(1) = 17.612, p = .000$ and $H(1) = 9.316, p = .002$, respectively (Figure 58 and Figure 59, Appendix G). It is important to point out that presentation medium has a highly significant effect on perceived usefulness for understandability and perceived ease of understanding due to very small p values specifically $p = .000$ and $p = .002$.

The analysis on the effect of presentation medium indicates that using paper or computer influences understandability task effectiveness and perceived understandability when it comes to the models of this type, structure and complexity.

4.4.3 Testing the Hypotheses on Experience with Process Models

The influence of experience with process models on understandability variables was analyzed in testing of H3. Kruskal-Wallis test results showed that experience with process models does not have a significant effect on any understandability variable stated in H3 group of hypotheses (Table 41, Appendix H).

4.4.4 Testing the Hypotheses on Intensity of Working with Process Models

Results of Kruskal-Wallis tests indicated that two understandability variables are significantly affected by intensity of working with process models (Table 42, Appendix I). First, the influence of intensity of working with process models on understandability task efficiency is found to be significant, $H(3) = 11.079, p = .011$ (Figure 60, Appendix I). Detecting a significant influence on task efficiency but not detecting a significant effect on task effectiveness points to the finding that intensity of working with process models has mainly an impact on the time spent for correctly answered questions. Pairwise comparisons using the Kruskal-Wallis test did not find a significant difference between groups (Figure 61, Appendix I). Thus, stepwise comparisons were applied and stepwise comparisons found that participants who do not encounter process models in practice and participants who encounter process models more than once a month achieved significantly better efficiency results than participants who encounter process models less than once a month and daily (Table 43, Appendix I). Second, it is found that rate of encountering process models in practice has a significant effect on perceived ease of understanding, $H(3) = 10.295, p = .016$ (Figure 62, Appendix I). Pairwise comparisons using the Kruskal-Wallis test did not find a significant difference between groups (Figure 63, Appendix I). Stepwise comparisons showed that participants who encounter process models considered to understand process models more difficult than other participants (Table 44, Appendix I).

4.4.5 Testing the Hypotheses on Familiarity with Process Domain

The influence of familiarity with the process domain on understandability variables was analyzed. Kruskal-Wallis test results indicated that familiarity with process domain does not have a significant effect on any of dependent variables in testing of H5 (Table 45, Appendix J).

4.4.6 Testing the Hypotheses on BP Modeling Knowledge

Statistical tests demonstrated that only understandability task efficiency among four dependent variables is significantly affected by BP modeling knowledge (Table 46, Appendix K). The knowledge on BP modeling has a significant effect on understandability task efficiency $H(3) = 10.286$, $p = .016$ (Figure 64, Appendix K). Pairwise comparisons using the Kruskal-Wallis test did not find a significant difference between groups (Figure 65, Appendix K). Stepwise comparisons found two homogeneous subsets where two conditions in each subset are the same (Table 47, Appendix K). Post hoc tests showed that mean ranks are sorted in the following order from largest to smallest: knowledgeable about, somewhat knowledgeable about, not knowledgeable about and very knowledgeable about. This order shows a decreasing amount of knowledge except 'very knowledgeable about'. This might be due to the low number of sample sizes for 'very knowledgeable about', $N = 16$ (3.1%).

4.4.7 Testing the Hypotheses on BPMN 2.0 Knowledge

Hypotheses in H7 are tested in this sub-section. According to results of Kruskal-Wallis test, two dependent variables are significantly affected by BPMN 2.0 knowledge (Table 48, Appendix L). Knowledge on BPMN 2.0 has a highly significant effect on understandability task efficiency, $H(3) = 39.461$, $p = .000$ (Figure 66, Appendix L). Pairwise comparisons using the Kruskal-Wallis test revealed that there are significant differences between 'Not knowledgeable about' and 'Knowledgeable about' ($p = .002$) and between 'Not knowledgeable about' and 'Somewhat knowledgeable about' ($p = .000$,) (Figure 67, Appendix L). Participants who are somewhat knowledgeable about BPMN 2.0 or knowledgeable about BPMN 2.0 achieved significantly better understandability task efficiency results than participants who are not knowledgeable about BPMN 2.0.

In testing of H7d, the influence of BPMN 2.0 knowledge on perceived ease of understanding is found to be significant, $H(3) = 11.454$, $p = .010$ (Figure 68, Appendix L). Pairwise comparisons using the Kruskal-Wallis test did not find a significant difference between groups (Figure 69, Appendix L). Stepwise comparisons created three homogeneous subsets, one of them consisting of two conditions, second one also consisting of two conditions and last one containing only one condition. According to stepwise comparisons, 'Very knowledgeable about' condition is significantly better than other conditions (Table 49, Appendix L). Also, the mean rank of this condition is by far the highest among four conditions.

4.4.8 Testing the Hypotheses on Theoretical Knowledge on BP Modeling and BPMN 2.0

Theoretical knowledge on BP modeling and BPMN 2.0 is measured by the number of correct answers of 15 questions. One of the assumptions of Kruskal-Wallis test is that the independent variable should be categorical. Due to this assumption, a categorical independent variable is formed by dividing the number of correct answers to 3. This variable consists of five groups and is used in the testing of hypothesis in H8. Different from testing

of other hypotheses, the sample size decreases from 510 to 390 since theoretical knowledge on BP modeling and BPMN 2.0 was measured only in Experiment 2 and Experiment 3.

The influence of theoretical knowledge on BP modeling and BPMN 2.0 on understandability variables were analyzed. According to results of Kruskal-Wallis test, only understandability task effectiveness is significantly affected by theoretical knowledge on BP modeling and BPMN 2.0 (Table 50, Appendix M).

The influence of theoretical knowledge on BP modeling and BPMN 2.0 on understandability task effectiveness is found to be significant, $H(4) = 16.35$, $p = .003$ (Figure 70, Appendix M). Pairwise comparisons using the Kruskal-Wallis test revealed that there are significant differences between Group 1 and Group 4 ($p = .003$) and Group 2 and Group 4 ($p = .022$) where groups are ranged from Group 0 to Group 4 with increasing success in the understandability questions (Figure 71, Appendix M). Participants in Group 4 had significantly better understandability task effectiveness results than participants in Group 1 or Group 2. Moreover, the mean rank of Group 4 is considerably higher than the mean ranks of other groups.

To sum up, significant relationships were found in testing of H1a, H1d, H2a, H2c, H2d, H4b, H4d, H6b, H7b, H7d and H8a. Only in testing of H1a, we can talk about a partial significant relationship since modularity representation does not have a direct significant influence on understandability task effectiveness but has a significant influence on task effectiveness considering some subsets of understandability questions.

4.5 Discussion

In this study, we investigated the effects of modularity representation and presentation medium on process model understandability from an empirical perspective in H1 and H2. Moreover, we tested the effects of external variables on process model understandability in H3, H4, H5, H6, H7 and H8.

Table 15 Summary of hypotheses testing

H.	Variable	Understandability task effectiveness	Understandability task efficiency	Perceived usefulness for understandability	Perceived ease of understanding
H1	Modularity representation	Partially supported	Not supported	Not supported	Supported
H2	Presentation medium	Supported	Not supported	Supported	Supported
H3	Experience with process models	Not supported	Not supported	Not supported	Not supported
H4	Intensity of working with process models	Not supported	Supported	Not supported	Supported
H5	Domain familiarity	Not supported	Not supported	Not supported	Not supported
H6	BP modeling knowledge	Not supported	Supported	Not supported	Not supported
H7	BPMN 2.0 knowledge	Not supported	Supported	Not supported	Supported
H8	Theoretical knowledge on BP modeling and BPMN 2.0	Supported	Not supported	Not supported	Not supported

The result of testing the influence of modularity representation on task effectiveness (H1a) is stated as 'Partially supported' because different forms of modularity representation does not have a significant influence on understandability task effectiveness but has a significant influence on understandability task effectiveness score regarding some understandability questions.

The source of the change in the factors should be noted. Forms of modularity representation and the medium used for presenting process models are the only manipulated factors as the research model dictated. Following five variables rely on self-assessments. The last variable, theoretical knowledge on BP modeling and BPMN 2.0, can be determined objectively. This variable has a direct influence on understandability task effectiveness, which is an important indicator for understandability. We investigated the results found in other studies which discuss the effect of independent variables and external variables we examined in this study in the following sub-sections.

4.5.1 Discussing the Effect of Modularity Representation

We found out five papers on the effect of forms of modularity representation on understandability and presented the results below.

Paper 1. Three empirical studies including five controlled experiments (E1, R1, E2, R2 and E3) were carried out to examine the effect of using composite states in UML statechart diagrams on the understandability of process models (Cruz-Lemus et al., 2009). Size and

complexity of UML statechart models differed in these empirical studies. In E1 and R1, the variable *understandability effectiveness (UEffec)* was used as the ability to understand process models correctly where two new variables, *transfer (UTrans)* and *retention (UReten)* were added in experiments E2, R2 and E3. These three variables were computed as the number of correct answers for specific tests. Considering the results of E1, R1, E2 and R2, the use of composite states did not significantly influence the understandability effectiveness of UML statechart diagrams. Results of statistical analyses for E3 revealed that there is a statistically significant effect of the use of composite states on the understandability in all three variables used. Composite states (modularization) was found to be useful for a better comprehension. The reasons for finding a significant effect only in E3 were evaluated as increasing complexity of tasks to be performed and usage of real practitioners as subjects instead of students in E3.

Paper 2. The influence of the use of different nesting levels of composite states in UML statechart diagrams was examined in a controlled experiment (E1) and its replication (R1) conducted with students (Cruz-Lemus et al., 2005). Three different diagrams were used with 0, 1 and 2 nesting levels (without composite states, with one level composite state and with composite states within composite states) as experimental material. Understandability of UML statechart diagrams were measured by dependent variables, effectiveness and efficiency. First dependent variable corresponds to number of correct answers and second dependent variable is calculated as number of correct answers divided by time spent on answering the questions. In E1, though the effectiveness and efficiency for 0 and 1 nesting levels were higher than values for 2 nesting levels, t-tests could not find a significant difference between different nesting levels. Differently from E1, statistically significant differences relating the effectiveness and efficiency between values 0 vs. 1 and 0 vs. 2 were obtained in R1. It was concluded that a flat nesting level (0 or 1) makes the diagrams more understandable than a bigger nesting level. Nevertheless, the optimal level of composite states within UML Statechart Diagrams could not be found.

Paper 3. Different visualization techniques for the process model hierarchy are analyzed in Figl et al. (2013). Expert evaluations were collected through a web-based questionnaire. Statistical test results for expert preferences in this empirical study showed that the *overview+detail* interface strategy is preferred over the *focus+context* strategy and there is a significant difference between *overview+detail* strategy and *focus+context* strategy when the visualization technique of the hierarchical relationships is *treemap*.

Paper 4. Effectiveness of the use of modularity in real-life process models was tested in an experiment conducted with 28 experienced consultants (Reijers et al., 2011). Two process models from practice were used in the experiment. Models have more than 100 tasks and can be considered as very large. A significant difference could not be found between the modular and the flattened version in terms of effectiveness for process model A, but there was a significant difference between two versions for process model B. The cause of this difference might be the higher degree of modularization of process model B - modular version than process model A - modular version.

Paper 5. The effect of modularity on the understandability of declarative business process models was investigated in an empirical study (Zugal et al., 2013). Nine subjects participated to the experiment and four processes were used. Eight questions for each process were asked to operationalize possible positive and negative effects of hierarchy. Level of understanding was measured by the mental effort expended for understandability questions and accuracy

(amount of correctly answered questions). A significant difference between flat and hierarchical models could not be found in terms of accuracy. On the other hand, statistical tests demonstrated that mental effort for questions that were asked in the hierarchical model was found to be significantly higher than the mental effort spent for flat models. This study is the only one which used mental effort to operationalize level of understanding. Low number of participants was reported as a threat to the generalization of the results.

The results of testing the effect of modularity representation on understandability in our study and other studies are presented in Table 16. We see different results for understandability task effectiveness, not significant effect and significant effect both in the positive and negative directions. In Paper 1, real practitioners were used in E3 where students participated to the experiments in E1, R1, E2 and R2. The complexity of the tasks to be performed was also increased. These two factors must have affected the results obtained. Results are affected by the previous experience of the subjects on modeling, as well as by the size and complexity of the UML statechart diagrams used in the experiments, so care should be taken when generalizing the results. Paper 2 achieved different results than Paper 1. Higher values for effectiveness and efficiency were obtained when the nesting level is 0. The flat UML statechart diagram (with the nesting level 0) has only 13 simple states. Thus, it can be more effective and efficient to understand such a relatively small model. Paper 3 considered preferences. Paper 4 showed that selected process model can change the results. A significant effect on effect on effectiveness could not be found in Paper 5 but use of modularity had a significant effect on mental effort and increased mental effort compared to not use of modularity. Our study differs from other studies in that it uses real world processes, BPMN process models as experimental objects and understandability questions are balanced in relation to different process perspectives and scope.

Table 16 Comparison of effects of modularity representation on understandability

	Und. task effectiveness	Und. task efficiency	PUU	PEU
Our Study	Not Sig., Sig. (for some process scope and perspectives) - negative effect	Not Sig.	Not Sig.	Sig. - negative effect
Paper 1 (Cruz-Lemus et al., 2009)	Not Sig. (E1, R1, E2, R2), Sig. (E3) - positive effect	-	-	-
Paper 2 (Cruz-Lemus et al., 2005)	Not Sig. (E1), Sig. (R1) - negative effect	Not Sig. (E1), Sig. (R1) - negative effect	-	-
Paper 3 (Figl et al., 2013)	-	-	Sig. (for a particular hierarchy technique) - positive effect	Sig. (for a particular hierarchy technique) - positive effect
Paper 4 (Reijers et al., 2011)	Not Sig. (Model A), Sig. (Model B) - positive effect	-	-	-
Paper 5 (Zugal et al., 2013)	Not Sig.	-	-	-

4.5.2 Discussing the Effect of Presentation Medium

The influence of presentation medium on understanding of process models has not been discussed in another empirical study.

4.5.3 Discussing the Effect of Experience with Process Models

There exist studies that examine the effect of process modeling experience on understandability (Mendling, Strembeck, et al., 2012; Reijers & Mendling, 2011; Storrle, 2012). We emphasize that process modeling experience is different than experience with process models. The influence of experience with process models on process model understandability has been examined in one empirical study. Table 17 shows the results of testing the effect of experience with process models on understandability in our study and other study. We found that experience with process does not have a significant influence on understandability. Different results were obtained in some cases in Paper 1.

Paper 1. The influence of BPM working experience on understandability was tested in Recker and Dreiling (2011). It is described as previous work experience in process management and corresponds to experience with process models in our study. Both transfer abilities and retention abilities were measured based on two different tests for testing the effect of examined factors on understandability. Moreover, to measure effort of understanding, task completion times for both types of test were recorded. In our study,

understandability task efficiency is not measured only by task completion time but for the comparison purpose we matched the completion time with understandability task efficiency.

Table 17 Comparison of effects of experience with process models on understandability

	Und. task effectiveness	Und. task efficiency	PUU	PEU
Our Study	Not Sig.	Not Sig.	Not Sig.	Not Sig.
Paper 1 (Recker & Dreiling, 2011)	Sig. (transfer ability - case 1), Not Sig. (transfer ability - case 1) Not Sig. (retention ability)	Not Sig. (transfer ability), Sig. (retention ability)	-	-

4.5.4 Discussing the effect of Intensity of Working with Process Models

We found that intensity of working with process models has a significant influence on understandability task efficiency and perceived ease of understanding as a result of testing of H4. The effect of rate of encountering with process models on process model understandability has been examined in one empirical study. Results of our study and results presented in Paper 1 can be seen in Table 18. It is observed that our results are compatible with the results obtained in Paper 1.

Paper 1. Intensity of working with process models was examined as a within-subjects factor to test its effect on understandability in an empirical study (Mendling, Strembeck, et al., 2012). It had four levels. Two dependent variables, comprehension task performance and comprehension task efficiency were used to measure understandability. It was found out that the differences between user groups with different levels of intensity of working with process models in terms of comprehension task performance are insignificant. On the other hand, differences in task completion efficiency across the user groups are significant.

Table 18 Comparison of effects of intensity of working with process models on understandability

	Und. task effectiveness	Und. task efficiency	PUU	PEU
Our Study	Not Sig.	Sig.	Not Sig.	Sig.
Paper 1 (Mendling, Strembeck, et al., 2012)	Not Sig.	Sig.	-	-

4.5.5 Discussing the Effect of Familiarity with Process Domain

In our study, familiarity with process domain is not found to have a significant influence on understandability as a result of testing of H5. The main effect of familiarity with process domain on process model understandability has been examined in one empirical study. Familiarity with the process domain was examined as a moderator factor on the relationship between labeling style and perceived usefulness (Mendling, Reijers, & Recker, 2010). We examine the main effect of familiarity with process domain on understandability. Thus, it is

not meaningful to compare the results of this study with the findings of our study. Table 19 shows the results of our study and results of Paper 1. It is observed that our results are compatible with the results obtained in Paper 1.

Paper 1. A significant influence of familiarity with the domain of the workflow on understandability was not observed as a result of three controlled experiments (Reggio, Ricca, Scanniello, Cerbo, & Dodero, 2013).

Table 19 Comparison of effects of familiarity with process domain on understandability

	Und. task effectiveness	Und. task efficiency	PUU	PEU
Our Study	Not Sig.	Not Sig.	Not Sig.	Not Sig.
Paper 1 (Reggio et al., 2013)	Not Sig.	-	-	-

4.5.6 Discussing the Effect of BP Modeling Knowledge

Testing of H6 showed that BP modeling knowledge has a significant influence only on understandability task efficiency. The influence of BP modeling knowledge on process model understandability has been examined in one empirical study. Results of our study and results of Paper 1 are presented in Table 20. It is observed that results of two studies are compatible with each other.

Paper 1. A person's process modeling knowledge on process modeling was measured as a personal factor to measure its effect on understandability (Reijers & Mendling, 2011). It was a self-assessment variable and had a five-point ordinal scale. The only dependent variable used for measuring understandability was task effectiveness. It was determined by evaluating answers to a set of seven closed questions and one open question. Analyses demonstrated that theoretical knowledge on process modeling does not have a significant effect on understandability task effectiveness.

Table 20 Comparison of effects of BP modeling knowledge on understandability

	Und. task effectiveness	Und. task efficiency	PUU	PEU
Our Study	Not Sig.	Sig.	Not Sig.	Not Sig.
Paper 1 (Reijers & Mendling, 2011)	Not Sig.	-	-	-

4.5.7 Discussing the Effect of BPMN 2.0 Knowledge

BPMN 2.0 knowledge was found to have a significant influence on understandability task efficiency and perceived ease of understanding in testing of H7. The effect of using different process modeling notations has been examined in many studies as discussed in Chapter 2 but the effect of BPMN 2.0 knowledge on process model understandability has been examined in one empirical study. Results obtained in our study and results obtained in Paper 1 are shown in Table 21. Two studies found out different results for the effect on understandability

task effectiveness. It can be due to differences in the measurement, competency of participants or characteristics of modeling notations / languages.

Paper 1. The effect of experience on modeling language on understandability was investigated in Reggio et al. (2013) with the assumption that participants' experience with UML (the language used to model workflows in the study) might effect understandability significantly. It is assumed that experience on modeling language can be matched with the knowledge on BPMN 2.0 in our study. A significant effect of experience with UML on understandability task effectiveness was observed indicating that more experienced participants comprehended workflows better. Two dependent variables were used in the study namely comprehension level and comprehension time. An analysis to find out the effect of experience with UML on comprehension time could not be found.

Table 21 Comparison of effects of BPMN 2.0 knowledge on understandability

	Und. task effectiveness	Und. task efficiency	PUU	PEU
Our Study	Not Sig.	Sig.	Not Sig.	Sig.
Paper 1 (Reggio et al., 2013)	Sig.	-	-	-

4.5.8 Discussing the Effect of Theoretical Knowledge on BP Modeling and BPMN 2.0

We found that theoretical knowledge on BP modeling and BPMN 2.0 has a significant influence on understandability task efficiency in testing of H8. The effect of rate of encountering with process models on process model understandability has been examined in one empirical study. Results of our study and results discussed in Paper 1 are presented in Table 22. It is observed that our results are partially compatible with the results obtained in Paper 1. According to statistical analyses presented in Paper 1, different levels of theoretical knowledge has a significant influence on understandability task efficiency with a p-value $p = .04$ which is near to limit of $.05$.

Paper 1. Theoretical knowledge on BP modeling and BPMN 2.0 was one of the factors examined in Mendling et al. (2012). Participants answered a theoretical knowledge test which consists of 12 questions on grammatical rules of process modeling logic. The knowledge score was transformed into an ordinal scale with four levels. Two dependent variables were used to measure; comprehension task performance and comprehension task efficiency. They were calculated with the same method used for understandability task effectiveness and understandability task efficiency in our study. Comprehension task performance and comprehension task efficiency across the four groups of theoretical knowledge were found to be significantly different.

Table 22 Comparison of effects of theoretical knowledge on BP modeling and BPMN 2.0 on understandability

	Und. task effectiveness	Und. task efficiency	PUU	PEU
Our Study	Sig.	Not Sig.	Not Sig.	Sig.
Paper 1 (Mendling, Strembeck, et al., 2012)	Sig	Sig.	-	-

4.5.9 Differences in the Experiments

Sample size in Experiment 1 (E1) is 120, sample size in Experiment 2 (E2) is 280 and finally, sample size in Experiment 3 (E3) is 110. Total sample size is 510. Differences among results of experiments are observed when they are analyzed separately. In this subsection, we investigate which characteristics might help to clarify these diverging effects.

Table 23 summarizes the results of testing H1 for each experiment. Though a significant effect of forms of modularity representation on understandability task effectiveness was not found as a result of testing H1a in Section 4.4.1, modularity representation has a significant influence on understandability task effectiveness in Experiment 1, $H(2) = 8.493$, $p = .014$ (Figure 72, Appendix N). Indeed, it is seen in Table 23 that the significant effects on dependent variables were found only in Experiment 1. Modularity representation was found to have a significant influence on three of the four dependent variables (respectively $p = .014$, $p = .001$ and $p = .001$) where in the general results it was found to have an effect only on perceived ease of understanding significantly. Participants of Experiment 1 are differed from other participants with their higher familiarity with the process domain and less BPMN 2.0 knowledge as discussed in Section 4.2.1.

Table 23 Results of the Kruskal-Wallis statistical tests for H1 by experiment

Variable: Modularity representation (H1)									
Exp.	Understandability task effectiveness		Understandability task efficiency		Perceived usefulness for understandability		Perceived ease of understanding		
	H	p	H	p	H	p	H	p	
E1	8.493	.014*	3.137	.208	13.116	.001*	13.593	.001*	
E2	.607	.738	.369	.831	.419	.811	2.372	.306	
E3	.160	.923	2.785	.248	.002	.999	.991	.609	

*. Correlation is significant at the .05 level (2-tailed).

Results of Kruskal-Wallis tests applied to examine the influence of presentation medium on understandability of process models, by each experiment are presented in Table 24. The effect of presentation medium on understandability task effectiveness in Experiment 2 can be regarded as significant since p was found to be .050 (Figure 73, Appendix N). The overall effect of presentation medium on understandability task effectiveness was found to be significant in testing of H2a. Participants of Experiment 3 did not indicate a significant difference on perceived understandability variables distinctly from participants of

Experiment 1 and Experiment 2 as it can be seen in Table 24. Only in Experiment 3, the mean for understandability task efficiency when computer format is used is higher than the mean value when paper format is used as it can be seen in Table 9. This might be due to participants in Experiment 3 heavily use computers in daily work.

Table 24 Results of the Kruskal-Wallis statistical tests for H2 by experiment

Variable: Presentation medium (H2)								
Exp.	Understandability task effectiveness		Understandability task efficiency		Perceived usefulness for understandability		Perceived ease of understanding	
	H	p	H	p	H	p	H	p
E1	1.892	.169	2.240	.134	9.539	.002*	4.316	.038*
E2	3.831	.050	.746	.388	7.060	.008*	6.234	.013*
E3	.089	.765	.069	.792	2.266	.132	.097	.755

*. Correlation is significant at the .05 level (2-tailed).

Kruskal-Wallis test results, with the values of H and p, analyzing the effect of experience with process models on understandability are displayed in Table 25. In Section 4.4.3, hypotheses in H4 are rejected showing that experience with process models does not have a significant influence on understandability of process models. When hypotheses in H4 are tested for each experiment separately, no significant effect was found again (Figure 74, Appendix N). Thus, consistent results are obtained when H4 is tested overall or separately for each experiment.

Table 25 Results of the Kruskal-Wallis statistical tests for H3 by experiment

Variable: Experience with process models (H3)								
Exp.	Understandability task effectiveness		Understandability task efficiency		Perceived usefulness for understandability		Perceived ease of understanding	
	H	p	H	p	H	p	H	p
E1	1.372	.849	4.679	.322	2.249	.690	2.768	.597
E2	5.123	.275	.717	.949	4.724	.317	6.169	.187
E3	4.933	.294	7.010	.135	1.036	.904	.508	.973

*. Correlation is significant at the .05 level (2-tailed).

The effect of intensity of working with process models on understandability is analyzed for each experiment and results of Kruskal-Wallis tests are presented in Table 26. According to these results, a significant influence of rate of encountering with process models on understandability task efficiency was found in testing with data of Experiment 2 (Figure 75, Appendix N). This is in line with the results of overall testing of H4b, intensity of working with process models has a significant influence on understandability task efficiency. These statistical results demonstrate that the intensity of dealing with models is a factor that influences understandability in terms of efficiency for students but it is not a factor that influences understandability for industry professionals. It can be seen in Table 26 that perceived ease of understanding is not affected significantly by intensity of working with

process models, differently perceived ease of understanding is affected significantly when the data of three experiments are examined together.

Table 26 Results of the Kruskal-Wallis statistical tests for H4 by experiment

Variable: Intensity of working with process models (H4)									
Exp.	Understandability task effectiveness		Understandability task efficiency		Perceived usefulness for understandability		Perceived ease of understanding		
	H	p	H	p	H	p	H	p	
E1	2.219	.528	4.509	.211	.423	.935	4.866	.182	
E2	1.716	.633	7.904	.048*	1.085	.781	3.471	.324	
E3	2.249	.522	5.236	.155	5.779	.123	3.479	.323	

*. Correlation is significant at the .05 level (2-tailed).

Results of Kruskal-Wallis tests conducted to examine the effect of familiarity with process domain on understandability of business process models in each experiment are displayed in Table 27. Familiarity with process domain is found to have significant influence on perceived usefulness for understandability in Experiment 2 and Experiment 3 and on perceived ease of understanding in Experiment 2 (Figure 76, Appendix N). However, a significant influence of familiarity with process domain on understandability is not found when all experiments are analyzed as one experiment in Section 4.4.5.

Table 27 Results of the Kruskal-Wallis statistical tests for H5 by experiment

Variable: Familiarity with process domain (H5)									
Exp.	Understandability task effectiveness		Understandability task efficiency		Perceived usefulness for understandability		Perceived ease of understanding		
	H	p	H	p	H	p	H	p	
E1	7.561	.109	1.235	.872	4.099	.393	2.870	.580	
E2	.396	.983	2.141	.710	10.762	.029*	15.044	.005*	
E3	8.252	.083	.840	.933	18.416	.001*	9.269	.055	

*. Correlation is significant at the .05 level (2-tailed).

Statistical test results analyzing the influence of process modeling knowledge on understandability are shown in Table 28. In testing of H6, BP modeling knowledge was found to affect understandability task efficiency significantly only. When the results are examined by each experiment, it is observed that knowledge in process modeling does not have an influence on task efficiency in any experiment. It can be seen that only perceived understandability variables were affected by BP modeling knowledge in Experiment 1 (Figure 77, Appendix N).

Table 28 Results of the Kruskal-Wallis statistical tests for H6 by experiment

Variable: BP modeling knowledge (H6)								
Exp.	Understandability task effectiveness		Understandability task efficiency		Perceived usefulness for understandability		Perceived ease of understanding	
	H	p	H	p	H	p	H	p
E1	1.657	.647	5.391	.145	8.440	.038*	10.682	.014*
E2	6.686	.083	6.133	.105	3.001	.392	5.882	.118
E3	1.918	.590	6.501	.090	1.864	.601	3.451	.327

*. Correlation is significant at the .05 level (2-tailed).

Kruskal-Wallis results showed that knowledge in process modeling notation, specifically BPMN 2.0 has an influence on mostly perceived understandability in our experiments. Other than perceived understandability, BPMN 2.0 knowledge was found to influence understandability task effectiveness in Experiment 3 only (Figure 78, Appendix N). This relationship is an important finding. It might be due to the more balanced distribution of mainly two groups; participants who do not have knowledge on BPMN 2.0 and participants who have at least some knowledge about BPMN 2.0, in Experiment 3. According to descriptive statistics presented in Section 4.2.1, subjects of Experiment 1 are mostly not knowledgeable about modeling notation and subjects of Experiment 2 are mostly at least somewhat knowledgeable.

Table 29 Results of the Kruskal-Wallis statistical tests for H7 by experiment

Variable: BPMN 2.0 knowledge (H7)								
Exp.	Understandability task effectiveness		Understandability task efficiency		Perceived usefulness for understandability		Perceived ease of understanding	
	H	p	H	p	H	p	H	p
E1	1.657	.647	5.391	.145	8.440	.038*	10.682	.014*
E2	2.096	.351	2.916	.233	1.729	.421	11.330	.003*
E3	9.766	.021*	2.594	.458	7.905	.048*	6.498	.090

*. Correlation is significant at the .05 level (2-tailed).

Results of Kruskal-Wallis tests investigating the influence of theoretical knowledge on process modeling and process modeling notation on process model understandability are shown in Table 30. There are two significant relationships when experiments are analyzed separately. One of them is on understandability task effectiveness and the other is on perceived usefulness for understandability task effectiveness respectively in Experiment 2, $H(4) = 17.661$, $p = .001$ and in Experiment 3, $H(4) = 13.884$, $p = .003$ (Figure 79, Appendix N). The first relationship is compatible with the overall results which demonstrated that theoretical knowledge has a significant influence on task effectiveness.

Table 30 Results of the Kruskal-Wallis statistical tests for H8 by experiment

Variable: Theoretical knowledge on BP modeling and BPMN 2.0 (H8)									
Exp.	Understandability task effectiveness		Understandability task efficiency		Perceived usefulness for understandability		Perceived ease of understanding		
	H	p	H	p	H	p	H	p	
E1	.027	.869	.011	.918	3.348	.067	1.570	.210	
E2	17.661	.001*	5.792	.122	1.492	.684	2.342	.505	
E3	1.879	.598	3.264	.353	13.884	.003*	7.546	.056	

*. Correlation is significant at the .05 level (2-tailed).

Even though, participants of Experiment 2 are graduate students who can be considered as the next generation of business professionals (Kitchenham et al., 2002) and it has been shown that, under some conditions, there is not a large difference between such students and professionals (Basili et al., 1999; Host, Regnell, & Wohlin, 2000), we have obtained different results between experiments. Meeting with differing results among experiments and even obtaining very different p values in some cases are remarkable. This finding is worthy to discuss. We might argue that there are still some personal factors affecting understandability that we might not be aware in this study.

4.5.10 Influence of Using Different Process Models

There are two process models used in the experiments. We evaluate results as if they were the same process due to similar structural properties presents in Table 4. In fact, they are mainly different processes and they have corresponding understandability questions. In this sub-section, descriptive statistics based on each process are examined. Then, the influence of forms of modularity and presentation medium on understandability are analyzed for each process model separately.

Table 31 presents the descriptive statistics for understandability task effectiveness based on two processes. Sample sizes for Process A and Process B are same which equals to 255 samples. Besides, we notice that sample sizes for groups are close making a meaningful comparison possible. For both Process A and Process B, the largest means (respectively $M = 5.13$, $SD = 1.61$ and $M = 5.88$, $SD = 1.56$) were obtained with Repr1 (fully-flattened representation) among different forms of modularity representation. It is important to notice that there is a very little difference between task effectiveness scores with Repr1 and Repr3 for Process A. As comparing the mean values according to presentation medium, it can be seen that the largest means (respectively $M = 5.10$, $SD = 1.63$ and $M = 5.95$, $SD = 1.61$) were achieved with paper format. For Process A, there exists a very little difference between two formats. Thus, we can conclude that for Process A, the mean values with different forms of modularity representation and presentation medium are near to each other while for Process B, there exist considerable differences between the mean values. Having generally higher scores for Process B shows that understandability questions for process B are easier than questions for Process A.

Table 31 Descriptive statistics (process based) - understandability task effectiveness

Level	Process A			Process B		
	N	\bar{X}	SD	N	\bar{X}	SD
Repr1	87	5.13	1.61	83	5.88	1.56
Repr2	84	5.02	1.54	87	5.78	1.59
Repr3	84	5.12	1.54	85	5.29	1.88
Computer	131	5.08	1.50	131	5.37	1.73
Paper	124	5.10	1.63	124	5.95	1.61

Descriptive statistics for understandability task efficiency based on two processes are shown in Table 32. Differently from understandability task effectiveness, highest mean values were obtained with different levels for two processes. Task efficiency has the highest mean ($M = 42.47$, $SD = 22.53$) among different forms of modularity representation when Repr3 is used for Process A where it has the highest mean ($M = 48.58$, $SD = 22.52$) with Repr1 for Process B. Higher understandability task efficiency results were obtained with paper format ($M = 42.55$, $SD = 22.46$) for Process A and with computer format ($M = 46.25$, $SD = 16.49$) for Process B. It is useful to note that the mean with computer format is slightly higher than paper format for Process B.

Table 32 Descriptive statistics (process based) - understandability task efficiency

Level	Process A			Process B		
	N	\bar{X}	SD	N	\bar{X}	SD
Repr1	87	38.60	17.76	83	48.58	22.52
Repr2	84	37.37	14.96	87	44.00	12.87
Repr3	84	42.47	22.53	85	44.76	21.44
Computer	131	36.55	13.78	131	46.25	16.49
Paper	124	42.55	22.46	124	45.20	22.08

Statistical tests found that modularity representation does not have a significant influence on any of the understandability indicators for Process A but modularity representation has a significant influence on two perceived understandability variables for Process B (Figure 80, Appendix O) as shown in Table 33. When Process B was examined only, it was found out that different forms of modularity representation has a significant influence on perceived usefulness for understandability, $H(2) = 7.033$, $p = .030$ and perceived ease of understanding, $H(2) = 16.241$, $p = .000$. For both understandability variables, the scores are significantly higher in Repr1 and Repr2 than in Repr3. These results are partially similar with general results where forms of modularity representation has a significant influence only on perceived ease of understanding (see Section 4.4.1).

Table 33 Results of the Kruskal-Wallis statistical tests for H1 by process

Variable: Modularity representation (H1)									
Process	Understandability task effectiveness		Understandability task efficiency		Perceived usefulness for understandability		Perceived ease of understanding		
	H	p	H	p	H	p	H	p	
Process A	.002	.999	2.043	.360	.301	.860	2.640	.267	
Process B	4.751	.093	2.953	.228	7.033	.030*	16.241	.000*	

*. Correlation is significant at the .05 level (2-tailed).

We performed further tests to investigate if the scores obtained from questions regarding different *process scope* (global / local) and *perspectives* (control flow / resource / information) show any major difference for understandability task effectiveness. The following relationships were found to be significant when processes are examined separately (Figure 81, Appendix O).

- *Process B*, Modularity Repr. → Und. Task Effectiveness (Local), $p = .011$
- *Process B*, Modularity Repr. → Und. Task Effectiveness (Only Local), $p = .000$
- *Process B*, Modularity Repr. → Und. Task Effectiveness (Control Flow), $p = .011$
- *Process B*, Modularity Repr. → Und. Task Effectiveness (Only Control Flow), $p = .011$

It is observed that all significant relationships were found for Process B. Three of four relationships also exist in general results which consider both processes together. The results of pairwise comparisons mostly match with the results when processes are investigated as one process indicating that participants given Repr1 or Repr2 got significantly higher scores than participants given Repr3.

We also performed similar tests for understandability task efficiency. Modularity representation is found to have a significant effect on task efficiency when understandability questions on specific process perspectives (control flow, resource and information) or a combination of these perspectives are considered only. Only one efficiency score concerning understandability questions which relate to all of three process perspectives differs significantly for Process A and again only one score concerning questions only related to control flow perspective differs significantly. Totally, two relationships were found to be significant when processes are examined separately (Figure 82, Appendix O).

- *Process A*, Modularity Repr. → Und. Task Efficiency (Control Flow, Resource and Information), $p = .000$
- *Process B*, Modularity Repr. → Und. Task Efficiency (Only Control Flow), $p = .032$

There are different results than general findings where task efficiency values obtained for questions concerning different process scopes and perspectives do not differ significantly according to different forms of modularity representation (See Section 4.4.1). Interestingly, the results demonstrate comparisons in reverse way for two relationships as discussed below.

- For *Process A*, participants given Repr3 (process models where sub-processes are used) as the form of modularity representation obtained significantly higher task

efficiency results than participants given Repr1 (flattened process model without the use of groups) or Repr2 (flattened process model with the use of groups) regarding questions related to all three perspectives,

- For *Process B*, participants given Repr2 (flattened process model with the use of groups) as the form of modularity representation obtained significantly better effectiveness results than participants given Repr3 (process models where sub-processes are used) regarding *control flow-only* questions.

Results of Kruskal-Wallis tests applied to examine the influence of presentation medium on understandability of process models, by each process are presented in Table 34. Results with Process B follow similar to general findings that outcome for both process models, i.e. presentation medium has a significant influence on understandability task effectiveness and perceived understandability variables. Surprisingly, it was found that presentation medium significantly effects task efficiency for Process A.

Table 34 Results of the Kruskal-Wallis statistical tests for H2 by process

Variable: Presentation medium (H2)								
Process	Understandability task effectiveness		Understandability task efficiency		Perceived usefulness for understandability		Perceived ease of understanding	
	H	p	H	p	H	p	H	p
Process A	.017	.896	4.190	.041*	6.373	.012*	1.385	.239
Process B	8.913	.003*	2.593	.107	12.520	.000*	10.366	.001*

*. Correlation is significant at the .05 level (2-tailed).

CHAPTER 5

5 CONCLUSION

Business process models are important elements at various phases of the BPM lifecycle. As such, their understandability for their intended audience is crucial. The findings of existing research on process model understandability and the findings of our study are expressed in this thesis. Our systematic literature review makes a contribution in summarizing the literature on business process model understandability research. It has resulted in a reference model (Figure 5) that represents all the factors contributing to an understandable process model and the indicators used for measuring process model understandability investigated in the literature. It provides guidance for further research about business process model understandability.

We have described the design and conduct of an experimental study to investigate two process model factors and additionally four personal factors that potentially influence process model understandability. We have examined if and how different forms of modularity representation and the medium used for the presentation influence the understandability of process models that are in the form of BPMN collaboration diagrams. Moreover, the effects of other factors such as expertise with business process models or domain familiarity have been analyzed and discussed in detail. To contribute to the generalizability of our findings, we used two real-life processes as the objects of our experiment and 255 participants as our subjects. The participants were employees of a large organization and potential audience of the models tested, students and lastly employees of a research institute who have expertise in software development. As we had participants from different backgrounds and organizations, level of BPM knowledge and level of familiarity with the BPMN of participants varied.

Our systematic literature review reveals that a primary study in the literature has an average of 85 participants in their experiments. With a total of 255 participants -including both practitioners and students, this study represents one of the first large-scale family of controlled experiments on the understandability of business process models. Among all primary studies, only one study has more than 255 subjects, specifically it had 284 participants. Glezer et al. (2005) argues that using students as participants in experiments is common due to following constraint professionals are not as available as students. Despite this observation, we had a high percentage of professionals among all participants with a ratio of 45% in our study which caused the experimental conditions to converge closer to real-life business settings.

Although the effect of process modeling notation and structural complexity have been extensively studied in the past 15 years, the effect of different modularity use in business process models on the understandability has remained relatively unexplored. Limited research into the influence of forms of modularity on the process model understandability provided empirical evidence for the positive influence of modularization (Cruz-Lemus et al., 2009; Reijers et al., 2011), negative influence of modularization (Cruz-Lemus et al., 2005) and no influence of modularization (Zugal et al., 2013). To the best of our knowledge and

results of our systematic literature review, our study is the first to examine the effects of presentation medium on understanding of business process models.

The results of our tests regarding the set of groups of hypotheses from H1 to H8 showed that,

- The *presentation medium* has significant impact on three of the four dependent variables,
- The *intensity of working with process models* and *BPMN 2.0 knowledge* have significant impact on two of the four dependent variables, and
- The *modularity representation*, *BP modeling knowledge* and *theoretical knowledge on BP modeling and BPMN 2.0* have significant impact on only one of the four dependent variables.

Our experiments provide empirical evidence on how the use of modularity and use of different presentation medium influence understanding of business process models that are modeled using BPMN 2.0. The results demonstrate that flattened process model (with or without the use of groups) as the form of modularity representation increased understandability than process models where sub-processes are used (regarding local, local-only and control flow-only questions). This finding is important, as the use of modularity is a recommended practice for dealing with the complexity of process models to improve their understandability. In practice, business process models are increasingly published and shared over an intranet to its users in electronic format (Recker & La Rosa, 2012). Despite this observation, our results suggest that process models presented in paper format are likely to be understood better. Summarizing these two findings, the results of our family of experiments indicate that for business practitioners, to optimally understand a BPMN model in the form of a collaboration diagram, it is best to present the model in a ‘flattened’ fashion (without using collapsed sub-processes in BPMN) in the ‘paper’ format.

The findings of our study are valuable and provide important contributions to the existing body of knowledge in the business process modeling field. The implications are both for practice and research. Overall, our study adds to the growing body of knowledge on design decisions in process modeling and contributes to the development of process modeling guidelines based on empirical findings.

5.1 Threats to Validity

In discussing the threats to the validity of our findings, we focus on four main types for quantitative research: conclusion, internal, construct and external validity (Wohlin et al., 2012).

Conclusion validity is the degree to which the conclusions we obtained are reasonable. It ensures that our conclusions are actually right and justified. In this perspective, two aspects are considered. First aspect evaluates the appropriateness of statistical tests used. We checked the assumption of normality according to the procedure we described in Section 4.3. This procedure made use of commonly used normality tests such as Kolmogorov-Smirnov and various visual graphs. We chose Kruskal-Wallis test (a non-parametric statistical test) to examine the effect of our independent variables and to study the influence of external variables due to non-normality of the experimental data. The second aspect considers the sample size. To increase sample size, we conducted two replications of our experiment as suggested in Basili et al. (1999). Total sample size (i.e. 510 samples) is considerably large to

predict meaningful relationships from the data sets. In order to test any bias between experiments, we have discussed the differences among experiments. As these practices are taken into consideration, conclusion validity is not violated.

Internal validity refers to whether an experimental treatment makes a difference or not. Internal validity threats deal with factors that may affect results in an undesirable way. To find out alternative causes for results, we tested the main effects of external variables on understandability. History threat concerns any information exchanged between participants within the same experiment session and among experiment sessions. Experiment 2 was conducted in one session and Experiment 3 was conducted in a small number of sessions. Participants were monitored during the experiments. They were asked to return back all the experimental material they used for the experiment. These practices helped to minimize the effect of history threat. Group threats are avoided by ensuring participants are allocated to conditions randomly. In order to deal with the learning effect, a short tutorial on BPMN 2.0 symbols was provided in the questionnaire. Four or five levels were used for ordinal external variables. We believe that this rough classification is enough to reflect reality.

Construct validity concerns the extent to which constructs (independent variables, dependent variables or experimental setting) accurately reflect the theoretical concepts they are intended to measure (Madeyski, 2010). Understandability task effectiveness was measured by the number of correctly answered understandability questions. In this study, we used nine understandability questions for each process model covering different process scope and perspectives since coverage of different aspects plays an important role (Laue & Gadatsch, 2010). The difficulty level of questions is another important topic which should be taken into consideration. The questions were neither too easy nor too hard as the descriptive statistics showed that the mean value of score is around 5 or 6. It is highly possible that we would have obtained a different picture if the tasks given to participants were different. Following a rigorous method in developing, verifying and validating the understandability questions contributes to the accuracy by which the understandability factors are operationalized. This reinforces the construct validity of our work. Time spent for answering understandability questions was collected automatically by the online environment used for the questionnaire. Potential interactions of external variables were inspected by correlation matrix in Section 4.2.3. Another aspect related to construct validity is the threat of experimenter expectancies. Experimenters can bias the results of a study both consciously and unconsciously based on what they expect from the experiment (Wohlin et al., 2012). We, as researchers in this work, did not explicate any desired outcome as we were indifferent to any result. Construct validity was strengthened within the study through the use of objectively measured independent variables and a number of external variables. On the other hand, some variables needed only a few multiple-choice questions to be answered because time constraints limit the number and types of questions to be asked.

External validity refers to the degree to which the results can be generalized. Threats falling into this category are mainly related to sample of population and objects used in the experiment. The models used for the experiments are real-life process models and can be considered as large and complex. The choice for such models affects the external validity of our study, i.e. the potential to generalize our findings, in a positive way (Reijers et al., 2011). Both professionals and students participated in our study and the experiments were conducted in three different organizational settings. Around half of the participants (45%) were practitioners. High number and percentage of the participants working in practice strengthen the generalizability of our findings. The strict replications of the experiments

(Experiment 2 and 3) also contributed to the external validity. The specific choice for the modularization of two processes can be regarded as a further threat to the validity of our findings. It is difficult to verify that the choices for the parts that are structured as sub-processes are optimal (but not arbitrary, which may lead to a flawed modularization (Reijers et al., 2011)). We addressed this risk by requesting domain experts (who also act as process modelers/owners in the case organization) to validate the models including their modularity structures.

5.2 Limitations and Future Work

Our findings and implications have a number of limitations from which several possible directions for future research emerge. The single experiment based research design severely limits generalization. On the other hand, as we discussed above, experimenting with real-life processes and business practitioners has a positive effect on the external validity of our study. This allows us to better generalize the results towards practical implications. However, having practitioners from two enterprises (despite being from 18 different departments in Experiment 1 and having 9 different types of expertise in Experiment 3) reduces this effect. Future research should consider involving practitioners with different backgrounds and working in diverse business environments.

Second, for the experiments, over 75% percent of the participants (Experiments 2 and 3) used their personal notebooks with different configurations. They might have used screens in different sizes and resolutions for displaying process models. A bigger size of screen and a higher resolution would cause better results in behalf of use of computer as presentation medium. As these participants faced different computer environments, there is a threat to the validity of the finding regarding the presentation medium. Future work should investigate this variable by making sure that all participants use a standard computer environment for the experiments, to reduce the possible effect of using computer environment with different size and resolutions.

Third, this study may be limited based on the selection of model cases. Our findings are valid only for BPMN collaboration diagrams, where a number of *pools* are used (each with a single control-flow). To understand the potential effect of using this type of BPMN models, future work should consider experimenting also with BPMN models where a single main control-flow is present (i.e. a single pool potentially with multiple lanes). Set of BPMN constructs used for modeling (zur Muehlen & Recker, 2008) is another factor to be experimented. Furthermore, we used two process models with similar size and complexity. Different results would be achieved if we used process models with different size and complexity. For instance, selecting a process model with 200 activity nodes as object would cause difficulties in answering the understandability questions when paper is used to display models. Future works should also use process models of different size, complexity, and applied level of modularity to better understand the interplay between these factors and contribute to the development of guidelines for applying modularization in business process modeling. Another improvement is experimenting the effect of modularity when other (theoretical) modularization approaches (such as Wand & Weber's (Wand & Weber, 1989) as in Johannsen et al. (2014) or heuristics evaluated in Milani et al. (2015) are employed.

Fourth, our family of experiments was not able to identify any influence of experience with process models or domain familiarity on understandability (based on the self-reported levels by the participants). On the other hand, statistical analyses demonstrated that theoretical

knowledge has a significant influence on understandability task effectiveness, which can be regarded as the primary construct of understandability (based on the results of a 15 questions theoretical test). Future research should consider using other methods to more objectively operationalize such factors (e.g. in the form of tests to quantify the level of experience or the familiarity with the domain).

Finally, we included hypotheses to test the effect of external variables. While we keep the effects of BPMN knowledge or domain familiarity under control, it is possible that further external variables like cultural differences exist. Future work would consider such factors in order to explain the variance in understandability better.

5.3 Implications for Research and Practice

The findings we present in this work have important implications for research and practice.

Our systematic literature review and our experiments report on different findings regarding the use of modularity in BPMN process models on understandability. In particular, the results of our experiments contradict to a large extent with the general view and assumptions on the use modularization. Thus, process modeling community – both industry and academia, needs to rethink the implications of modularization when BPMN models are of concern. Given the increasing popularity of BPMN as a modeling notation, future research in process model understandability should consider additional experiments to test the effect of modularization under diverse settings.

Our findings also emphasize the importance of the presentation medium, which is a factor that has been neglected in previous works. Using paper or a computer environment has a significant influence on three of the four understandability factors indicating that paper is participants' preferred choice of medium. As such, the BPM systems and process modeling tools that publish process models in digital forms may consider offering additional features to the users (e.g. animations, dynamic representations, search functions) to address this drawback.

Our results confirm the importance of personal factors to the understanding of process models. Our experiments showed that *BPM competencies* has a significant influence on process model understandability. The results indicate that knowledge on the theoretical aspects of process modeling and process modeling notation has stronger effect than the practical experience with process models. However, further research -both from a theoretical and behavioral perspective- is required to investigate the effects of human factors in business process modeling.

We highlighted the significant influence of theoretical knowledge on BP modeling and notation on the understandability task effectiveness – a key metric that we used for operationalizing understandability. This demonstrates that it is essential to provide training on the theoretical concepts of business process modeling and notation to the employees across the organization to help decrease resistance to such initiatives and potentially gain increased commitment.

Our empirical work on the understandability of process models also points out a need for a set of guidelines that provide standards and rules in planning, conducting and reporting on such empirical works. These guidelines would help in establishing valid experiments and

reporting in a systematic way, which in turn would help to contribute to the accurate measurement of the constructs and validity of the findings.



REFERENCES

- Adler, M. (1988). An Algebra for Data Flow Diagram Process Decomposition. *IEEE Transactions on Software Engineering*, 14(2), 169–183. <http://doi.org/10.1109/32.4636>
- Bandara, W., Gable, G. G., & Rosemann, M. (2005). Factors and measures of business process modelling: model building through a multiple case study. *European Journal of Information Systems*, 14(4), 347–360. <http://doi.org/10.1057/palgrave.ejis.3000546>
- Basili, V. R., Shull, F., & Lanubile, F. (1999). Building Knowledge through Families of Experiments. *IEEE Transactions on Software Engineering*, 25(4), 456–473. <http://doi.org/10.1109/32.799939>
- Becker, J., Rosemann, M., & Uthmann, C. Von. (2000). Guidelines of Business Process Modeling. In W. van der Aalst, J. Desel, & A. Oberweis (Eds.), *Business Process Management - Models, Techniques, and Empirical Studies* (pp. 30–49). Springer Berlin Heidelberg. http://doi.org/10.1007/3-540-45594-9_3
- Bennedsen, J., & Caspersen, M. E. (2006). Abstraction Ability as an Indicator of Success for Learning Object-Oriented Programming? *ACM SIGCSE Bulletin*, 38(2), 39–43. <http://doi.org/10.1145/1138403.1138430>
- Bernstein, V., & Soffer, P. (2015). Identifying and Quantifying Visual Layout Features of Business Process Models. In K. Gaaloul, R. Schmidt, S. Nurcan, S. Guerreiro, & Q. Ma (Eds.), *16th International Conference on Business Process Modeling, Development and Support* (Vol. 214, pp. 200–213). Stockholm, Sweden: Springer International Publishing. http://doi.org/10.1007/978-3-319-19237-6_13
- Bodart, F., Patel, A., Sim, M., & Weber, R. (2001). Should Optional Properties Be Used in Conceptual Modeling? A Theory and Three Empirical Tests. *Information Systems Research*, 12(4), 383–405. Retrieved from <http://pubsonline.informs.org/doi/abs/10.1287/isre.12.4.384.9702>
- Burton-Jones, A., & Meso, P. (2008). The Effects of Decomposition Quality and Multiple Forms of Information on Novices' Understanding of a Domain from a Conceptual Model. *Journal of the Association for Information Systems*, 9(12), 784–802. Retrieved from <http://aisel.aisnet.org/jais/vol9/iss12/1>
- Burton-Jones, A., & Meso, P. N. (2006). Conceptualizing Systems for Understanding: An Empirical Test of Decomposition Principles in Object-Oriented Analysis. *Information Systems Research*, 17(1), 38–60. <http://doi.org/10.1287/isre.1050.0079>
- Burton-Jones, A., Wand, Y., & Weber, R. (2009). Guidelines for Empirical Evaluations of Conceptual Modeling Grammars. *Journal of the Association for Information Systems*, 10(6), 495–532. Retrieved from <http://aisel.aisnet.org/jais/vol10/iss6/1/>
- Chinosi, M., & Trombetta, A. (2012). BPMN: An introduction to the standard. *Computer Standards & Interfaces*, 34(1), 124–134. <http://doi.org/10.1016/j.csi.2011.06.002>
- Creswell, J. W. (2014). *Research Design Qualitative, Quantitative, and Mixed Methods*

Approaches, 4th Edition. SAGE Publications, Inc. Retrieved from <https://uk.sagepub.com/en-gb/eur/research-design/book237357>

- Cruz-Lemus, J. A., Genero, M., Manso, M. E., Morasca, S., & Piattini, M. (2009). Assessing the understandability of UML statechart diagrams with composite states—A family of empirical studies. *Empirical Software Engineering, 14*(6), 685–719. <http://doi.org/10.1007/s10664-009-9106-z>
- Cruz-Lemus, J. A., Genero, M., Piattini, M., & Toval, A. (2005). An Empirical Study of the Nesting Level of Composite States Within UML Statechart Diagrams. In J. Akoka, S. W. Liddle, I.-Y. Song, M. Bertolotto, I. Comyn-Wattiau, W.-J. van den Heuvel, ... H. C. Mayr (Eds.), *Perspectives in Conceptual Modeling - ER 2005 Workshops AOIS, BP-UML, CoMoGIS, eCOMO, and QoIS, Klagenfurt, Austria, October 24-28, 2005. Proceedings* (pp. 12–22). Springer Berlin Heidelberg. http://doi.org/10.1007/11568346_3
- Curtis, B., Kellner, M. I., & Over, J. (1992). Process Modeling. *Communications of the ACM, 35*(9), 75–90.
- Damij, N. (2007). Business process modelling using diagrammatic and tabular techniques. *Business Process Management Journal, 13*(1), 70–90. <http://doi.org/10.1108/14637150710721131>
- Davis, F. D. (1989). Perceived Usefulness, Perceived Ease Of Use, and User Acceptance of Information Technology. *MIS Quarterly, 13*(3), 319–340. <http://doi.org/10.2307/249008>
- de Oca, I. M.-M., Snoeck, M., Reijers, H. A., & Rodriguez-Morffi, A. (2015). A systematic literature review of studies on business process modeling quality. *Information and Software Technology, 58*, 187–205. <http://doi.org/10.1016/j.infsof.2014.07.011>
- Dehnert, J., & van der Aalst, W. M. P. (2004). Bridging the Gap Between Business Models and Workflow Specifications. *International Journal of Cooperative Information Systems, 13*(3), 289–332.
- Devillers, M. (2011). *Business Process Modeling as a means to bridge The Business-IT Divide*. Radboud University Nijmegen.
- Dong, M., & Chen, F. F. (2005). Petri net-based workflow modelling and analysis of the integrated manufacturing business processes. *International Journal of Advanced Manufacturing Technology, 26*(9), 1163–1172. <http://doi.org/10.1007/s00170-004-2089-4>
- Dumas, M., La Rosa, M., Mendling, J., & Reijers, H. A. (2013). *Fundamentals of Business Process Management*. Springer. Retrieved from <http://www.springer.com/computer/information+systems+and+applications/book/978-3-642-33142-8>
- Felder, R. M., & Brent, R. (2005). Understanding Student Differences. *Journal of Engineering Education, 94*(1), 57–72. Retrieved from

http://www4.ncsu.edu/unity/lockers/users/f/felder/public/Papers/Understanding_Differences.pdf

- Felder, R. M., & Silverman, L. K. (1988). Learning and Teaching Styles in Engineering Education. *Engineering Education*, 78(7), 674–681. <http://doi.org/10.1109/FIE.2008.4720326>
- Feltovich, P. J., Hoffman, R. R., Woods, D., & Roesler, A. (2004). Keeping It Too Simple: How the Reductive Tendency Affects Cognitive Engineering. *IEEE Intelligent Systems*, 19(3), 90–94. <http://doi.org/10.1109/MIS.2004.14>
- Field, A. (2013). *Discovering Statistics using IBM SPSS Statistics, 4th Edition*. SAGE Publications Ltd. Retrieved from <http://studysites.sagepub.com/field4e/main.htm>
- Field, A., & Hole, G. (2003). *How to Design and Report Experiments*. SAGE Publications Ltd. Retrieved from <https://uk.sagepub.com/en-gb/eur/how-to-design-and-report-experiments/book219351>
- Figl, K., Koschmider, A., & Kriglstein, S. (2013). Visualising Process Model Hierarchies. In *21st European Conference on Information Systems* (p. Paper 180). Retrieved from http://aisel.aisnet.org/ecis2013_cr/180
- Gassen, J. B., Mendling, J., Thom, L. H., & de Oliveira, J. P. M. (2015). Towards Guiding Process Modelers Depending upon Their Expertise Levels. In A. Persson & J. Stirna (Eds.), *CAiSE 2015 International Workshops* (pp. 69–80). Stockholm, Sweden: Springer International Publishing. http://doi.org/10.1007/978-3-319-19243-7_6
- Gemino, A., & Wand, Y. (2004). A framework for empirical evaluation of conceptual modeling techniques. *Requirements Engineering*, 9(4), 248–260. <http://doi.org/10.1007/s00766-004-0204-6>
- Glezer, C., Last, M., Nachmany, E., & Shoval, P. (2005). Quality and comprehension of UML interaction diagrams-an experimental comparison. *Information and Software Technology*, 47(10), 675–692. <http://doi.org/10.1016/j.infsof.2005.01.003>
- Goguen, J. A., & Varela, F. J. (1979). Systems and Distinctions; Duality and Complementarity. *International Journal of General Systems*, 5(1), 31–43.
- Gonzalez, L. S., Rubio, F. G., Gonzalez, F. R., & Velthuis, M. P. (2010). Measurement in business processes: a systematic review. *Business Process Management Journal*, 16(1), 114–134. <http://doi.org/10.1108/14637151011017976>
- Guceglioglu, A. S. (2006). *A Pre-enactment Model for Measuring Process Quality*. Middle East Technical University.
- Harmon, P., & Wolf, C. (2014). *The State of Business Process Management 2014*. Retrieved from <http://ww.bptrends.com/>
- Hauser, R. F., Friess, M., Kuster, J. M., & Vanhatalo, J. (2008). An Incremental Approach to the Analysis and Transformation of Workflows Using Region Trees. *IEEE Transactions on Systems, Man and Cybernetics Part C: Applications and Reviews*,

38(3), 347–359. <http://doi.org/10.1109/TSMCC.2008.919178>

- Host, M., Regnell, B., & Wohlin, C. (2000). Using Students as Subjects - A Comparative Study of Students and Professionals in Lead-Time Impact Assessment. *Empirical Software Engineering*, 5(3), 201–214. <http://doi.org/10.1023/A:1026586415054>
- Houy, C., Fettke, P., & Loos, P. (2012). Understanding Understandability of Conceptual Models: What Are We Actually Talking about? In *Int. Conference on Conceptual Modeling, ER-2012* (pp. 64–77). Springer. http://doi.org/10.1007/978-3-642-34002-4_5
- Houy, C., Fettke, P., & Loos, P. (2014). ON THE THEORETICAL FOUNDATIONS OF RESEARCH INTO THE UNDERSTANDABILITY OF BUSINESS PROCESS MODELS. In *22nd European Conference on Information Systems*. Tel Aviv. Retrieved from <http://aisel.aisnet.org/ecis2014/proceedings/track06/7/>
- Indulska, M., Green, P., Recker, J., & Rosemann, M. (2009). Business Process Modeling: Perceived Benefits. In A. H. F. Laender, S. Castano, U. Dayal, F. Casati, & J. P. M. de Oliveira (Eds.), *Conceptual Modeling - ER 2009. 28th International Conference on Conceptual Modeling, Gramado, Brazil, November 9-12, 2009. Proceedings* (pp. 458–471). Springer Berlin Heidelberg. http://doi.org/10.1007/978-3-642-04840-1_34
- Johannsen, F., & Leist, S. (2012). Wand and Weber's Decomposition Model in the Context of Business Process Modeling. *Business & Information Systems Engineering*, 4(5), 271–286. <http://doi.org/Johannsen>
- Johannsen, F., Leist, S., & Braunnagel, D. (2014). Testing the Impact of Wand and Weber's Decomposition Model on Process Model Understandability. In *35th International Conference on Information Systems* (pp. 1–20). Retrieved from <http://aisel.aisnet.org/cgi/viewcontent.cgi?article=1256&context=icis2014>
- Johannsen, F., Leist, S., & Tausch, R. (2014). Wand and Weber's good decomposition conditions for BPMN: An interpretation and differences to Event-Driven Process Chains. *Business Process Management Journal*, 20(5), 693–729. <http://doi.org/10.1108/BPMJ-03-2013-0031>
- Kam, C. D., Wilking, J. R., & Zechmeister, E. J. (2007). Beyond the "Narrow Data Base": Another Convenience Sample for Experimental Research. *Political Behavior*, 29(4), 415–440. <http://doi.org/10.1007/s11109-007-9037-6>
- Kanfer, R., Ackerman, P. L., Murtha, T. C., Dugdale, B., & Nelson, L. (1994). Goal Setting, Conditions of Practice, and Task Performance: A Resource Allocation Perspective. *Journal of Applied Psychology*, 79(6), 826–835. <http://doi.org/10.1037/0021-9010.79.6.826>
- Kember, D., Biggs, J., & Leung, D. Y. P. (2004). Examining the multidimensionality of approaches to learning through the development of a revised version of the Learning Process Questionnaire. *British Journal of Educational Psychology*, 261–280. <http://doi.org/10.1348/000709904773839879>
- Kirschner, P. A. (2002). Cognitive load theory: implications of cognitive load theory on the

design of learning. *Learning and Instruction*, 12(1), 1–10.
[http://doi.org/10.1016/S0959-4752\(01\)00014-7](http://doi.org/10.1016/S0959-4752(01)00014-7)

Kitchenham, B. A., & Charters, S. (2007). *Guidelines for performing Systematic Literature Reviews in Software Engineering*. Retrieved from http://www.elsevier.com/__data/promis_misc/525444systematicreviewsguide.pdf

Kitchenham, B. A., Pfleeger, S. L., Pickard, L. M., Jones, P. W., Hoaglin, D. C., El Emam, K., & Rosenberg, J. (2002). Preliminary Guidelines for Empirical Research in Software Engineering. *IEEE Transactions on Software Engineering*, 28(8), 721–734.
<http://doi.org/10.1109/TSE.2002.1027796>

Kock Jr, N. F., & McQueen, R. J. (1996). Product flow, breadth and complexity of business processes. *Business Process Re-Engineering & Management Journal*, 2(2), 8–22. Retrieved from <http://www.emeraldinsight.com/doi/full/10.1108/14637159610148040>

Koschmider, A., & Blanchard, E. (2007). User Assistance for Business Process Model Decomposition. In *1st International Conference on Research Challenges in Information Science* (pp. 445–454). Ouarzazate, Morocco: IEEE.

Kothari, C. R. (2004). *Research Methodology: Methods and Techniques*. New Age International.

Krogstie, J., Sindre, G., & Jorgensen, H. (2006). Process models representing knowledge for action: a revised quality framework. *European Journal of Information Systems*, 15(1), 91–102. <http://doi.org/10.1057/palgrave.ejis.3000598>

La Rosa, M., ter Hofstede, A. H. M., Wohed, P., Reijers, H. A., Mendling, J., & van der Aalst, W. M. P. (2011). Managing Process Model Complexity via Concrete Syntax Modifications. *IEEE Transactions on Industrial Informatics*, 7(2), 255–265.
<http://doi.org/10.1109/TII.2011.2124467>

La Rosa, M., Wohed, P., Mendling, J., ter Hofstede, A. H. M., Reijers, H. A., & van der Aalst, W. M. P. (2011). Managing Process Model Complexity via Abstract Syntax Modifications. *IEEE Transactions on Industrial Informatics*, 7(4), 614–629.

Lakhotia, A. (1993). Understanding someone else's code: Analysis of experiences. *Journal of Systems and Software*, 23(3), 269–275. [http://doi.org/10.1016/0164-1212\(93\)90101-3](http://doi.org/10.1016/0164-1212(93)90101-3)

Langlois, R. N. (2002). Modularity in technology and organization. *Journal of Economic Behavior & Organization*, 49(1), 19–37. [http://doi.org/10.1016/S0167-2681\(02\)00056-2](http://doi.org/10.1016/S0167-2681(02)00056-2)

Laue, R., & Gadatsch, A. (2010). Measuring the Understandability of Business Process Models - Are We Asking the Right Questions? In M. zur Muehlen & J. Su (Eds.), *Business Process Management Workshops: BPM 2010 International Workshops and Education Track* (pp. 37–48). Hoboken, NJ, USA: Springer Berlin Heidelberg.
http://doi.org/10.1007/978-3-642-20511-8_4

Laue, R., & Mendling, J. (2010). Structuredness and its significance for correctness of

- process models. *Information Systems and E-Business Management*, 8(3), 287–307. <http://doi.org/10.1007/s10257-009-0120-x>
- Leymann, F., & Roller, D. (1997). Workflow-based applications. *IBM Systems Journal*, 36(1), 102–123. <http://doi.org/10.1147/sj.361.0102>
- Lindland, O. I., Sindre, G., & Solvberg, A. (1994). Understanding Quality in Conceptual Modeling. *IEEE Software*, 42–49. <http://doi.org/10.1109/52.268955>
- Madeyski, L. (2010). The impact of Test-First programming on branch coverage and mutation score indicator of unit tests: An experiment. *Information and Software Technology*, 52(2), 169–184. <http://doi.org/10.1016/j.infsof.2009.08.007>
- Malinova, M., Leopold, H., & Mendling, J. (2013). An Empirical Investigation on the Design of Process Architectures. In *11th International Conference on Wirtschaftsinformatik* (pp. 1197–1211). Leipzig, Germany. Retrieved from <http://aisel.aisnet.org/wi2013/75/>
- Malinova, M., & Mendling, J. (2015). Why is BPMN not appropriate for Process Maps? In *Thirty Sixth International Conference on Information Systems* (pp. 1–16). Fort Worth, Texas. Retrieved from <http://aisel.aisnet.org/icis2015/proceedings/ISdesign/12/>
- Masri, K., Parker, D., & Gemino, A. (2008). Using iconic graphics in entity-relationship diagrams: the impact on understanding. *Journal of Database Management*, 19(3), 22–41. <http://doi.org/10.4018/jdm.2008070102>
- Mayer, R. E. (2001). *Multimedia Learning*. Cambridge University Press. Retrieved from <http://dx.doi.org/10.1017/CBO9781139164603>
- Mendling, J. (2009). Empirical Studies in Process Model Verification. In K. Jensen & W. van der Aalst (Eds.), *Transactions on Petri Nets and Other Models of Concurrency II* (Vol. 5460, pp. 208–224). http://doi.org/10.1007/978-3-642-00899-3_12
- Mendling, J., Neumann, G., & van der Aalst, W. (2007). Understanding the Occurrence of Errors in Process Models Based on Metrics. In R. Meersman & Z. Tari (Eds.), *On the Move to Meaningful Internet Systems 2007* (pp. 113–130). Vilamoura, Portugal: Springer Berlin Heidelberg. http://doi.org/10.1007/978-3-540-76848-7_9
- Mendling, J., Reijers, H. A., & Cardoso, J. (2007). What Makes Process Models Understandable? In G. Alonso, P. Dadam, & M. Rosemann (Eds.), *5th International Conference on Business Process Management* (pp. 48–63). Brisbane, Australia: Springer Berlin Heidelberg. http://doi.org/10.1007/978-3-540-75183-0_4
- Mendling, J., Reijers, H. A., & Recker, J. (2010). Activity labeling in process modeling: Empirical insights and recommendations. *Information Systems*, 35(4), 467–482. <http://doi.org/10.1016/j.is.2009.03.009>
- Mendling, J., Reijers, H. A., & van der Aalst, W. M. P. (2010). Seven process modeling guidelines (7PMG). *Information and Software Technology*, 52(2), 127–136. <http://doi.org/10.1016/j.infsof.2009.08.004>

- Mendling, J., Sanchez-Gonzalez, L., Garcia, F., & La Rosa, M. (2012). Thresholds for error probability measures of business process models. *Journal of Systems and Software*, 85(5), 1188–1197. <http://doi.org/10.1016/j.jss.2012.01.017>
- Mendling, J., & Strembeck, M. (2008). Influence Factors of Understanding Business Process Models. In *11th International Conference on Business Information Systems* (pp. 142–153).
- Mendling, J., Strembeck, M., & Recker, J. (2012). Factors of process model comprehension—Findings from a series of experiments. *Decision Support Systems*, 53(1), 195–206. <http://doi.org/10.1016/j.dss.2011.12.013>
- Mendling, J., Verbeek, H. M. W., van Dongen, B. F., van der Aalst, W. M. P., & Neumann, G. (2008). Detection and prediction of errors in EPCs of the SAP reference model. *Data & Knowledge Engineering*, 64(1), 312–329. <http://doi.org/10.1016/j.datak.2007.06.019>
- Milani, F., Dumas, M., Matulevicius, R., Ahmed, N., & Kasela, S. (2015). Criteria and Heuristics for Business Process Model Decomposition. *Business & Information Systems Engineering*, 58(1), 7–17. <http://doi.org/10.1007/s12599-015-0413-1>
- Mili, H., Tremblay, G., Jaoude, G. B., Lefebvre, E., Elabed, L., & Boussaidi, G. El. (2010). Business Process Modeling Languages: Sorting Through the Alphabet Soup. *ACM Computing Surveys*, 43(1), 1–56. <http://doi.org/10.1145/1824795.1824799>
- Miller, J. (2000). Applying meta-analytical procedures to software engineering experiments. *Journal of Systems and Software*, 54(1), 29–39. [http://doi.org/10.1016/S0164-1212\(00\)00024-8](http://doi.org/10.1016/S0164-1212(00)00024-8)
- Moody, D. L. (2003). The Method Evaluation Model: A Theoretical Model for Validating Information Systems Design Methods. In *11th European Conference on Information Systems* (pp. 1311–1326). Naples, Italy. Retrieved from <http://aisel.aisnet.org/ecis2003/79/>
- Moody, D. L. (2004). Cognitive Load Effects on End User Understanding of Conceptual Models: An Experimental Analysis. In A. Benczur, J. Demetrovics, & G. Gottlob (Eds.), *8th East European Conference on Advances in Databases and Information Systems, ADBIS 2004* (pp. 129–143). Budapest, Hungary: Springer Berlin Heidelberg. http://doi.org/10.1007/978-3-540-30204-9_9
- Moody, D. L. (2005). Theoretical and practical issues in evaluating the quality of conceptual models: current state and future directions. *Data & Knowledge Engineering*, 55(3), 243–276. <http://doi.org/10.1016/j.datak.2004.12.005>
- Moody, D. L., Sindre, G., Brasethvik, T., & Solvberg, A. (2002). Evaluating the Quality of Process Models: Empirical Analysis of a Quality Framework. In *21st International Conference on Conceptual Modeling (ER 2002)* (pp. 380–396).
- Nelson, H. J., Poels, G., Genero, M., & Piattini, M. (2012). A conceptual modeling quality framework. *Software Quality Journal*, 20(1), 201–228. <http://doi.org/10.1007/s11219->

011-9136-9

- Nigam, A., & Caswell, N. S. (2003). Business artifacts: An approach to operational specification. *IBM Systems Journal*, 42(3), 428–445. <http://doi.org/10.1147/sj.423.0428>
- Object Management Group. (2014). BPMN Version 2.0.2. Retrieved June 10, 2016, from <http://www.omg.org/spec/BPMN/2.0.2/>
- Object Management Group. (2015). OMG UML Version 2.5. <http://doi.org/10.1007/s002870050092>
- Overhage, S., Birkmeier, D. Q., & Schlauderer, S. (2012). Quality Marks, Metrics, and Measurement Procedures for Business Process Models. *Business & Information Systems Engineering*, 4(5), 229–246. <http://doi.org/10.1007/s12599-012-0230-8>
- Parnas, D. L. (1972). On the Criteria To Be Used in Decomposing Systems into Modules. *Communications of the ACM*, 15(12), 1053–1058. <http://doi.org/10.1145/361598.361623>
- Pinggera, J. (2014). *The Process of Process Modeling*. University of Innsbruck.
- Pituch, K. A., Whittaker, T. A., & Stevens, J. P. (2007). *Intermediate Statistics: A Modern Approach, Third Edition*. Routledge. Retrieved from <https://www.routledge.com/products/9780805854664>
- Poels, G. (2011). Understanding Business Domain Models: The Effect of Recognizing Resource-Event-Agent Conceptual Modeling Structures. *Journal of Database Management*, 22(1), 69–101. Retrieved from <http://dl.acm.org/citation.cfm?id=2447880>
- Recker, J. (2010). Continued Use of Process Modeling Grammars: The Impact of Individual Difference Factors. *European Journal of Information Systems*, 19(1), 76–92. <http://doi.org/10.1057/ejis.2010.5>
- Recker, J. (2011). *Evaluations of Process Modeling Grammars*. Springer-Verlag Berlin Heidelberg. <http://doi.org/10.1007/978-3-642-18360-7>
- Recker, J. (2012). Empirical investigation of the usefulness of Gateway constructs in process models. *European Journal of Information Systems*, 22(6), 673–689. <http://doi.org/10.1057/ejis.2012.50>
- Recker, J. (2014). Suggestions for the Next Wave of BPM Research: Strengthening the Theoretical Core and Exploring the Protective Belt. *Journal of Information Technology Theory and Application*, 15(2), 5–20. Retrieved from <http://aisel.aisnet.org/cgi/viewcontent.cgi?article=1577&context=jitta>
- Recker, J., & Dreiling, A. (2011). The Effects of Content Presentation Format and User Characteristics on Novice Developers' Understanding of Process Models. *Communications of the Association for Information Systems*, 28(6), 65–84. Retrieved from <http://aisel.aisnet.org/cais/vol28/iss1/6>

- Recker, J., & La Rosa, M. (2012). *BPM Technology Research - the Case of Apromore*. *BPTrends* (Vol. 9). Retrieved from <http://www.bptrends.com/class-notes-bpm-research-and-education-bpm-technology-research-the-case-of-apromore/>
- Recker, J., & Mendling, J. (2015). The State of the Art of Business Process Management Research as Published in the BPM Conference. *Business & Information Systems Engineering*, 1–18. <http://doi.org/10.1007/s12599-015-0411-3>
- Recker, J., Rosemann, M., Green, P., & Indulska, M. (2011). Do Ontological Deficiencies in Modeling Grammars Matter? *MIS*, 35(1), 57–79. Retrieved from <http://misq.org/cat-articles/do-ontological-deficiencies-in-modeling-grammars-matter.html>
- Recker, J., Rosemann, M., Indulska, M., & Green, P. (2009). Business Process Modeling- A Comparative Analysis. *Journal of the Association for Information Systems*, 10(4), 333–363. Retrieved from <http://aisel.aisnet.org/jais/vol10/iss4/1/>
- Reggio, G., Ricca, F., Scanniello, G., Cerbo, F. Di, & Dodero, G. (2013). On the comprehension of workflows modeled with a precise style: results from a family of controlled experiments. *Software and Systems Modeling*, 1–24. <http://doi.org/10.1007/s10270-013-0386-9>
- Reijers, H. A., & Mendling, J. (2008). Modularity in Process Models: Review and Effects. In M. Dumas, M. Reichert, & M.-C. Shan (Eds.), *6th International Conference on Business Process Management* (pp. 20–35). Milan, Italy: Springer Berlin Heidelberg. http://doi.org/10.1007/978-3-540-85758-7_5
- Reijers, H. A., & Mendling, J. (2011). A Study Into the Factors That Influence the Understandability of Business Process Models. *IEEE Transactions on Systems, Man, and Cybernetics*, 41(3), 449–462.
- Reijers, H. A., Mendling, J., & Dijkman, R. M. (2011). Human and automatic modularizations of process models to enhance their comprehension. *Information Systems*, 36(5), 881–897. <http://doi.org/10.1016/j.is.2011.03.003>
- Reijers, H. A., Mendling, J., & Recker, J. (2010). Business Process Quality Management. In J. vom Brocke & M. Rosemann (Eds.), *Handbook on Business Process Management 1: Introduction, Methods and Information Systems* (pp. 167–185). Berlin, Heidelberg: Springer Berlin Heidelberg. <http://doi.org/10.1007/978-3-642-00416-2>
- Reijers, H. A., Recker, J., & Wouw, S. G. van de. (2010a). An Integrative Framework of the Factors Affecting Process Model Understanding: A Learning Perspective. In *16th Americas Conference on Information Systems* (pp. 12–15).
- Reijers, H. A., Recker, J., & Wouw, S. G. van de. (2010b). An Integrative Framework of the Factors Affecting Process Model Understanding: A Learning Perspective. In *16th Americas Conference on Information Systems* (pp. 12–15).
- Rolon, E., Cardoso, J., Garcia, F., Ruiz, F., & Piattini, M. (2009). Analysis and Validation of Control-Flow Complexity Measures with BPMN Process Models. In T. Halpin, J. Krogstie, S. Nurcan, E. Proper, R. Schmidt, P. Soffer, & R. Ukor (Eds.), *Enterprise*,

- Business-Process and Information Systems Modeling - 10th International Workshop, BPMDS 2009, and 14th International Conference, EMMSAD 2009, held at CAiSE 2009, Amsterdam, The Netherlands, June 8-9, 2009. Proceedings* (pp. 58–70). Springer Berlin Heidelberg. http://doi.org/10.1007/978-3-642-01862-6_6
- Rosemann, M. (2006). Potential pitfalls of process modeling: part A. *Business Process Management Journal*, 12(2), 249–254. <http://doi.org/10.1108/14637150610657567>
- Sanchez-Gonzalez, L., Garcia, F., Ruiz, F., & Mendling, J. (2012). Quality indicators for business process models from a gateway complexity perspective. *Information and Software Technology*, 54(11), 1159–1174. <http://doi.org/10.1016/j.infsof.2012.05.001>
- Scheer, A.-W. (2002). EPC. Retrieved June 15, 2016, from <http://www.ariscommunity.com/event-driven-process-chain>
- Schrepfer, M. (2010). *Modeling Guidelines for Business Process Models*. Humboldt-Universität zu Berlin.
- Schuette, R., & Rotthowe, T. (1998). The Guidelines of Modeling - An Approach to Enhance the Quality in Information Models. In T.-W. Ling, S. Ram, & M. L. Lee (Eds.), *17th International Conference on Conceptual Modeling* (pp. 240–254). Singapore: Springer Berlin Heidelberg. http://doi.org/10.1007/978-3-540-49524-6_20
- Sharp, A., & Mcdermott, P. (2008). *Workflow Modeling: Tools for Process Improvement and Application Development, Second Edition*. Artech House. Retrieved from <http://www.artechhouse.com/International/Books/Workflow-Modeling-Tools-for-Process-Improvement-an-1298.aspx>
- Shull, F., Basili, V., Carver, J., Maldonado, J. C., Travassos, G. H., Mendonca, M., & Fabbri, S. (2002). Replicating Software Engineering Experiments: Addressing the Tacit Knowledge Problem. In *2002 International Symposium on Empirical Software Engineering* (pp. 7–16). Nara, Japan: IEEE Computer Society. <http://doi.org/10.1109/ISESE.2002.1166920>
- Sjoberg, D. I. K., Hannay, J. E., Hansen, O., Kampenes, V. B., Karahasanovic, A., Liborg, N.-K., & Rekdal, A. C. (2005). A Survey of Controlled Experiments in Software Engineering. *IEEE Transactions on Software Engineering*, 31(9), 733–753. <http://doi.org/10.1109/TSE.2005.97>
- Smirnov, S., Reijers, H. A., & Weske, M. (2012). From fine-grained to abstract process models: A semantic approach. *Information Systems*, 37(8), 784–797. <http://doi.org/10.1016/j.is.2012.05.007>
- Stitzlein, C., Sanderson, P., & Indulska, M. (2013). Understanding healthcare processes: An evaluation of two process model notations. In *Human Factors and Ergonomics Society 57th Annual Meeting* (pp. 240–244). Retrieved from <http://pro.sagepub.com/content/57/1/240.full.pdf>
- Storrle, H. (2012). On the Impact of Layout Quality to Understanding UML Diagrams: Diagram Type and Expertise. In *2012 IEEE Symposium on Visual Languages and*

- Human-Centric Computing (VL/HCC)* (pp. 49–56). Innsbruck: IEEE. <http://doi.org/10.1109/VLHCC.2012.6344480>
- Sweller, J. (1988). Cognitive Load During Problem Solving: Effects on Learning. *Cognitive Science*, 12(2), 257–285. http://doi.org/10.1207/s15516709cog1202_4
- Sweller, J. (1994). Cognitive Load Theory, Learning Difficulty, and Instructional Design. *Learning and Instruction*, 4, 295–312. [http://doi.org/10.1016/0959-4752\(94\)90003-5](http://doi.org/10.1016/0959-4752(94)90003-5)
- Turetken, O., & Demirors, O. (2011). Plural: A decentralized business process modeling method. *Information & Management*, 48(6), 235–247. <http://doi.org/10.1016/j.im.2011.06.001>
- van der Aalst, W. M. P. (1997). Verification of workflow nets. In P. Azema & G. Balbo (Eds.), *18th International Conference on Application and Theory of Petri Nets* (Vol. 1248, pp. 407–426). Toulouse, France: Springer-Verlag Berlin Heidelberg. Retrieved from <http://dl.acm.org/citation.cfm?id=733919>
- van der Aalst, W. M. P. (2012a). A Decade of Business Process Management Conferences: Personal Reflections on a Developing Discipline. In A. Barros, A. Gal, & E. Kindler (Eds.), *10th International Conference on Business Process Management* (pp. 1–16). Tallinn, Estonia: Springer Berlin Heidelberg. http://doi.org/10.1007/978-3-642-32885-5_1
- van der Aalst, W. M. P. (2012b). What makes a good process model? *Software and Systems Modeling*, 11(4), 557–569. <http://doi.org/10.1007/s10270-012-0265-9>
- van der Aalst, W. M. P., & Pesic, M. (2006). DecSerFlow: Towards a Truly Declarative Service Flow Language. In M. Bravetti, M. Nunez, & G. Zavaratto (Eds.), *Web Services and Formal Methods* (Vol. 4184, pp. 1–23). Vienna, Austria: Springer Berlin Heidelberg. http://doi.org/10.1007/11841197_1
- van der Aalst, W. M. P., & ter Hofstede, A. H. M. (2005). YAWL: yet another workflow language. *Information Systems*, 30(4), 245–275. <http://doi.org/10.1016/j.is.2004.02.002>
- van der Aalst, W., & van Hee, K. (2002). *Workflow Management: Models, methods and systems*. Cambridge, MA: MIT Press. http://doi.org/10.1007/978-3-322-90847-6_2
- Vanhatalo, J., Volzer, H., & Leymann, F. (2007). Faster and More Focused Control-Flow Analysis for Business Process Models Through SESE Decomposition. In B. J. Kramer, K.-J. Lin, & P. Narasimhan (Eds.), *Fifth International Conference on Service Oriented Computing, ICSOC 2007* (Vol. 4749, pp. 43–55). Vienna, Austria: Springer Berlin Heidelberg. http://doi.org/10.1007/978-3-540-74974-5_4
- Venkatesh, V., Morris, M. G., Davis, G. B., & Davis, F. D. (2003). User Acceptance of Information Technology: Toward a Unified View. *MIS Quarterly*, 27(3), 425–478. Retrieved from <http://dl.acm.org/citation.cfm?id=2017197.2017202>
- Wand, Y., & Weber, R. (1989). A Model of Systems Decomposition. In *ICIS 1989*. Retrieved from <http://aisel.aisnet.org/icis1989/48>

- Wand, Y., & Weber, R. (1990). An Ontological Model of an Information System. *IEEE Transactions on Software Engineering*, 16(11), 1282–1292. <http://doi.org/10.1109/32.60316>
- Wang, Y., Wang, Y., Patel, S., & Patel, D. (2003). A Layered Reference Model of the Brain (LRMB). *IEEE Transactions on Systems, Man, and Cybernetics*, 36(2), 124–133. <http://doi.org/10.1109/TSMCC.2006.871126>
- Webster, J., & Watson, R. T. (2002). Analyzing the past to prepare for the future: Writing a literature review. *MIS Quarterly*, 26(2), xiii–xxiii. Retrieved from <http://aisel.aisnet.org/misq/vol26/iss2/3/>
- Wickens, C. D., & Kramer, A. (1985). Engineering Psychology. *Ann. Rev. Psychol.*, 36(1), 307–348. Retrieved from <http://www.annualreviews.org/doi/pdf/10.1146/annurev.ps.36.020185.001515>
- Winn, W. (1993). An Account of How Readers Search for Information in Diagrams. *Contemporary Educational Psychology*, 18(2), 162–185. Retrieved from <http://www.sciencedirect.com/science/article/pii/S0361476X83710167>
- Wohlin, C., Runeson, P., Host, M., Ohlsson, M. C., Regnell, B., & Wesslen, A. (2012). *Experimentation in Software Engineering*. Springer-Verlag Berlin Heidelberg. <http://doi.org/10.1007/978-3-642-29044-2>
- Zerguini, L. (2004). A Novel Hierarchical Method For Decomposition And Design Of Workflow Models. *Journal of Integrated Design & Process Science*, 8(2), 65–74. Retrieved from <http://content.iospress.com/articles/journal-of-integrated-design-and-process-science/jid8-2-06>
- Zugal, S., Pinggera, J., Reijers, H., Reichert, M., & Weber, B. (2012). Making the Case for Measuring Mental Effort. In *2nd International Workshop on Experiences and Empirical Studies in Software Modelling, EESSMod 2012* (pp. 37–42). Innsbruck, Austria: ACM Press. <http://doi.org/10.1145/2424563.2424571>
- Zugal, S., Pinggera, J., Weber, B., Mendling, J., & Reijers, H. A. (2011). Assessing the Impact of Hierarchy on Model Understandability - A Cognitive Perspective. In J. Kienzle (Ed.), *MODELS 2011 Workshops* (pp. 123–133). Wellington, New Zealand: Springer Berlin Heidelberg. http://doi.org/10.1007/978-3-642-29645-1_14
- Zugal, S., Soffer, P., Haisjackl, C., Pinggera, J., Reichert, M., & Weber, B. (2013). Investigating expressiveness and understandability of hierarchy in declarative business process models. *Software & Systems Modeling*, 14(3), 1081–1103. <http://doi.org/10.1007/s10270-013-0356-2>
- Zugal, S., Soffer, P., Pinggera, J., & Weber, B. (2012). Expressiveness and Understandability Considerations of Hierarchy in Declarative Business Process Models. In I. Bider, T. Halpin, J. Krogstie, S. Nurcan, E. Proper, R. Schmidt, ... S. Wrycza (Eds.), *Enterprise, Business-Process and Information Systems Modeling - 13th International Conference, BPMDS 2012, 17th International Conference, EMMSAD 2012, and 5th EuroSymposium, held at CAiSE 2012, Gdańsk, Poland, June 25-26,*

2012. *Proceedings* (pp. 167–181). Springer Berlin Heidelberg.
http://doi.org/10.1007/978-3-642-31072-0_12

zur Muehlen, M., & Recker, J. (2008). How Much Language Is Enough? Theoretical and Practical Use of the Business Process Modeling Notation. In Z. Bellahsene & M. Leonard (Eds.), *20th International Conference on Advanced Information Systems Engineering* (pp. 465–479). Montpellier, France: Springer Berlin Heidelberg.
http://doi.org/10.1007/978-3-540-69534-9_35





APPENDICES

APPENDIX A: PRIMARY STUDIES

LIST OF PRIMARY STUDIES

- [S1] Agarwal R, De P, Sinha AP (1999) Comprehending Object and Process Models: An Empirical Study. *IEEE Trans Softw Eng* 25:541–556. doi: 10.1109/32.799953
- [S2] Anda B, Sjoberg D, Jorgensen M (2001) Quality and Understandability of Use Case Models. In: Knudsen JL (ed) 15th European Conference on Object-Oriented Programming, ECOOP 2001. Springer Berlin Heidelberg, Budapest, Hungary, pp 402–428
- [S3] Cruz-Lemus JA, Genero M, Manso ME, et al (2009) Assessing the understandability of UML statechart diagrams with composite states—A family of empirical studies. *Empir Softw Eng* 14:685–719. doi: 10.1007/s10664-009-9106-z
- [S4] Cruz-Lemus JA, Genero M, Piattini M, Toval A (2005) An Empirical Study of the Nesting Level of Composite States Within UML Statechart Diagrams. In: Akoka J, Liddle SW, Song I-Y, et al. (eds) Perspectives in Conceptual Modeling - ER 2005 Workshops AOIS, BP-UML, CoMoGIS, eCOMO, and QoIS, Klagenfurt, Austria, October 24-28, 2005. Proceedings. Springer Berlin Heidelberg, pp 12–22
- [S5] Cruz-Lemus JA, Maes A, Genero M, et al (2010) The impact of structural complexity on the understandability of UML statechart diagrams. *Inf Sci (Ny)* 180:2209–2220. doi: <http://dx.doi.org/10.1016/j.ins.2010.01.026>
- [S6] Dumas M, Rosa M La, Mendling J, et al (2012) Understanding Business Process Models: The Costs and Benefits of Structuredness. In: Ralyte J, Franch X, Brinkkemper S, Wrycza S (eds) Advanced Information Systems Engineering 24th International Conference, CAiSE 2012, Gdansk, Poland, June 25-29, 2012. Proceedings. Springer Berlin Heidelberg, pp 31–46
- [S7] Figl K, Koschmider A, Kriglstein S (2013a) Visualising Process Model Hierarchies. In: 21st European Conference on Information Systems. p Paper 180
- [S8] Figl K, Laue R (2011) Cognitive Complexity in Business Process Modeling. In: Mouratidis H, Rolland C (eds) Advanced Information Systems Engineering 23rd International Conference, CAiSE 2011, London, UK, June 20-24, 2011. Proceedings. Springer Berlin Heidelberg, pp 452–466
- [S9] Figl K, Mendling J, Strembeck M (2013b) The Influence of Notational Deficiencies on Process Model Comprehension. *J Assoc Inf Syst* 14:312–338.
- [S10] Figl K, Recker J, Mendling J (2013c) A study on the effects of routing symbol design on process model comprehension. *Decis Support Syst* 54:1104–1118. doi: 10.1016/j.dss.2012.10.037

- [S11] Garcia F, Piattini M, Ruiz F, Visaggio CA (2005) Maintainability of Software Process Models: An Empirical Study. In: Ninth European Conference on Software Maintenance and Reengineering, 2005. IEEE, pp 246–255
- [S12] Genero M, Miranda D, Piattini M (2003) Defining Metrics for UML Statechart Diagrams in a Methodological Way. In: Jeusfeld MA, Pastor O (eds) Conceptual Modeling for Novel Application Domains - ER 2003 Workshops ECOMO, IWCMQ, AOIS, and XSDM, Chicago, IL, USA, October 13, 2003. Proceedings. Springer Berlin Heidelberg, pp 118–128
- [S13] Glezer C, Last M, Nachmany E, Shoval P (2005) Quality and comprehension of UML interaction diagrams-an experimental comparison. *Inf Softw Technol* 47:675–692. doi: 10.1016/j.infsof.2005.01.003
- [S14] Gross A, Doerr J (2009) EPC vs. UML Activity Diagram - Two Experiments Examining their Usefulness for Requirements Engineering. In: 17th IEEE International Requirements Engineering Conference, 2009. RE '09. IEEE, pp 47–56
- [S15] Hadar I, Reinhartz-Berger I, Kuflik T, et al (2013) Comparing the comprehensibility of requirements models expressed in Use Case and Tropos: Results from a family of experiments. *Inf Softw Technol* 55:1823–1843. doi: 10.1016/j.infsof.2013.05.003
- [S16] Haisjackl C, Zugal S (2014) Investigating Differences between Graphical and Textual Declarative Process Models. In: Iliadis L, Papazoglou M, Pohl K (eds) 26th International Conference on Advanced Information Systems Engineering. Springer International Publishing, pp 194–206
- [S17] Koschmider A, Kriglstein S, Ullrich M (2013) Investigations on User Preferences of the Alignment of Process Activities, Objects and Roles. In: Meersman R, Panetto H, Dillon T, et al. (eds) On the Move to Meaningful Internet Systems: OTM 2013 Conferences Confederated International Conferences: CoopIS, DOA-TrusteD Cloud, and ODBASE 2013, Graz, Austria, September 9-13, 2013. Proceedings. Springer Berlin Heidelberg, pp 57–74
- [S18] Mendling J, Reijers HA, Recker J (2010) Activity labeling in process modeling: Empirical insights and recommendations. *Inf Syst* 35:467–482. doi: 10.1016/j.is.2009.03.009
- [S19] Mendling J, Strembeck M, Recker J (2012) Factors of process model comprehension—Findings from a series of experiments. *Decis Support Syst* 53:195–206. doi: 10.1016/j.dss.2011.12.013
- [S20] Mturi E, Johannesson P (2014) A context-based process semantic annotation model for a process model repository. *Bus Process Manag J* 19:404–430. doi: 10.1108/14637151311319888
- [S21] Otero MC, Dolado JJ (2005) An empirical comparison of the dynamic modeling in OML and UML. *J Syst Softw* 77:91–102. doi: 10.1016/j.jss.2004.11.022
- [S22] Otero MC, Dolado JJ (2004) Evaluation of the comprehension of the dynamic modeling in UML. *Inf Softw Technol* 46:35–53. doi: 10.1016/S0950-5849(03)00108-3
- [S23] Ottensooser A, Fekete A, Reijers HA, et al (2012) Making sense of business process descriptions: An experimental comparison of graphical and textual notations. *J Syst Softw* 85:596–606. doi: 10.1016/j.jss.2011.09.023

- [S24] Peleg M, Dori D (2000) The Model Multiplicity Problem: Experimenting with Real-Time Specification Methods. *IEEE Trans Softw Eng* 26:742–759. doi: 10.1109/32.879812
- [S25] Pichler P, Weber B, Zugal S, et al (2012) Imperative versus Declarative Process Modeling Languages: An Empirical Investigation. In: Daniel F, Barkaoui K, Dustdar S (eds) *Business Process Management Workshops - BPM 2011 International Workshops*, Clermont-Ferrand, France, August 29, 2011, Revised Selected Papers, Part I. Springer Berlin Heidelberg, pp 383–394
- [S26] Purchase HC, Colpoys L, McGill M, Carrington D (2002) UML collaboration diagram syntax: an empirical study of comprehension. In: *Proceedings of the First International Workshop on Visualizing Software for Understanding and Analysis (VISSOFT 02)*. IEEE, Paris, France, pp 13–22
- [S27] Recker J (2012) Empirical investigation of the usefulness of Gateway constructs in process models. *Eur J Inf Syst* 22:673–689. doi: 10.1057/ejis.2012.50
- [S28] Recker J, Dreiling A (2007) Does It Matter Which Process Modelling Language We Teach or Use? An Experimental Study on Understanding Process Modelling Languages without Formal Education. In: *18th Australasian Conference on Information Systems*. Toowoomba, Australia, pp 356–366
- [S29] Recker J, Dreiling A (2011) The Effects of Content Presentation Format and User Characteristics on Novice Developers' Understanding of Process Models. *Commun Assoc Inf Syst* 28:65–84.
- [S30] Recker J, Reijers HA, van de Wouw SG (2014) Process Model Comprehension: The Effects of Cognitive Abilities, Learning Style, and Strategy. *Commun Assoc Inf Syst* 34:199–222.
- [S31] Reggio G, Ricca F, Scanniello G, et al (2013) On the comprehension of workflows modeled with a precise style: results from a family of controlled experiments. *Softw Syst Model* 1–24. doi: 10.1007/s10270-013-0386-9
- [S32] Reijers HA, Freytag T, Mendling J, Eckleder A (2011a) Syntax highlighting in business process models. *Decis Support Syst* 51:339–349. doi: 10.1016/j.dss.2010.12.013
- [S33] Reijers HA, Mendling J (2011) A Study Into the Factors That Influence the Understandability of Business Process Models. *IEEE Trans Syst Man Cybern* 41:449–462.
- [S34] Reijers HA, Mendling J, Dijkman RM (2011b) Human and automatic modularizations of process models to enhance their comprehension. *Inf Syst* 36:881–897. doi: 10.1016/j.is.2011.03.003
- [S35] Rolon E, Cardoso J, Garcia F, et al (2009) Analysis and Validation of Control-Flow Complexity Measures with BPMN Process Models. In: Halpin T, Krogstie J, Nurcan S, et al. (eds) *Enterprise, Business-Process and Information Systems Modeling - 10th International Workshop, BPMDS 2009, and 14th International Conference, EMMSAD 2009, held at CAiSE 2009, Amsterdam, The Netherlands, June 8-9, 2009*. Proceedings. Springer Berlin Heidelberg, pp 58–70
- [S36] Sanchez-Gonzalez L, Garcia F, Mendling J, Ruiz F (2010) Prediction of Business Process Model Quality Based on Structural Metrics. In: Parsons J, Saeki M, Shoval P,

- et al. (eds) *Conceptual Modeling – ER 2010 - 29th International Conference on Conceptual Modeling*, Vancouver, BC, Canada, November 1-4, 2010. Proceedings. Springer Berlin Heidelberg, pp 458–463
- [S37] Sanchez-Gonzalez L, Garcia F, Ruiz F, Mendling J (2012) Quality indicators for business process models from a gateway complexity perspective. *Inf Softw Technol* 54:1159–1174. doi: 10.1016/j.infsof.2012.05.001
- [S38] Sarshar K, Loos P (2005) Comparing the Control-Flow of EPC and Petri Net from the End-User Perspective. In: van der Aalst WMP, Benatallah B, Casati F, Curbera F (eds) *3rd International Conference on Business Process Management*. Springer Berlin Heidelberg, Nancy, France, pp 434–439
- [S39] Stitzlein C, Sanderson P, Indulska M (2013) Understanding healthcare processes: An evaluation of two process model notations. In: *Human Factors and Ergonomics Society 57th Annual Meeting*. pp 240–244
- [S40] Storrle H (2011) On the Impact of Layout Quality to Understanding UML Diagrams. In: *2011 IEEE Symposium on Visual Languages and Human-Centric Computing (VL/HCC)*. IEEE, Pittsburgh, PA, pp 135–142
- [S41] Storrle H (2012) On the Impact of Layout Quality to Understanding UML Diagrams: Diagram Type and Expertise. In: *2012 IEEE Symposium on Visual Languages and Human-Centric Computing (VL/HCC)*. IEEE, Innsbruck, pp 49–56
- [S42] Storrle H (2014) On the Impact of Layout Quality to Understanding UML Diagrams: Size Matters. In: Dingel J, Schulte W, Ramos I, et al. (eds) *ACM/IEEE 17th International Conference on Model Driven Engineering Languages and Systems*. Springer International Publishing, pp 518–534
- [S43] Weitlaner D, Guettinger A, Kohlbacher M (2013) Intuitive Comprehensibility of Process Models. In: Fischer H, Schneeberger J (eds) *5th International Conference on Subject-Oriented Business Process Management*. Springer Berlin Heidelberg, pp 52–71
- [S44] Yue T, Briand LC, Labiche Y (2013) Facilitating the Transition from Use Case Models to Analysis Models: Approach and Experiments. *ACM Trans Softw Eng Methodol* 22:1–38. doi: 10.1145/2430536.2430539
- [S45] Zugal S, Soffer P, Haisjackl C, et al (2013) Investigating expressiveness and understandability of hierarchy in declarative business process models. *Softw Syst Model* 14:1081–1103. doi: 10.1007/s10270-013-0356-2

APPENDIX B: PROCESS MODELS

PROCESS MODELS

CAPA Repr1 (Fully flattened)

CAPA Repr2 (Flattened with groups)

CAPA Repr3 (Modular form with sub-processes)

CAPA Repr3 Sub-processes

CH Repr1 (Fully flattened)

CH Repr2 (Flattened with groups)

CH Repr3 (Modular form with sub-processes)

CH Repr3 Sub-processes

CAPA Repr2 (Flattened with groups):

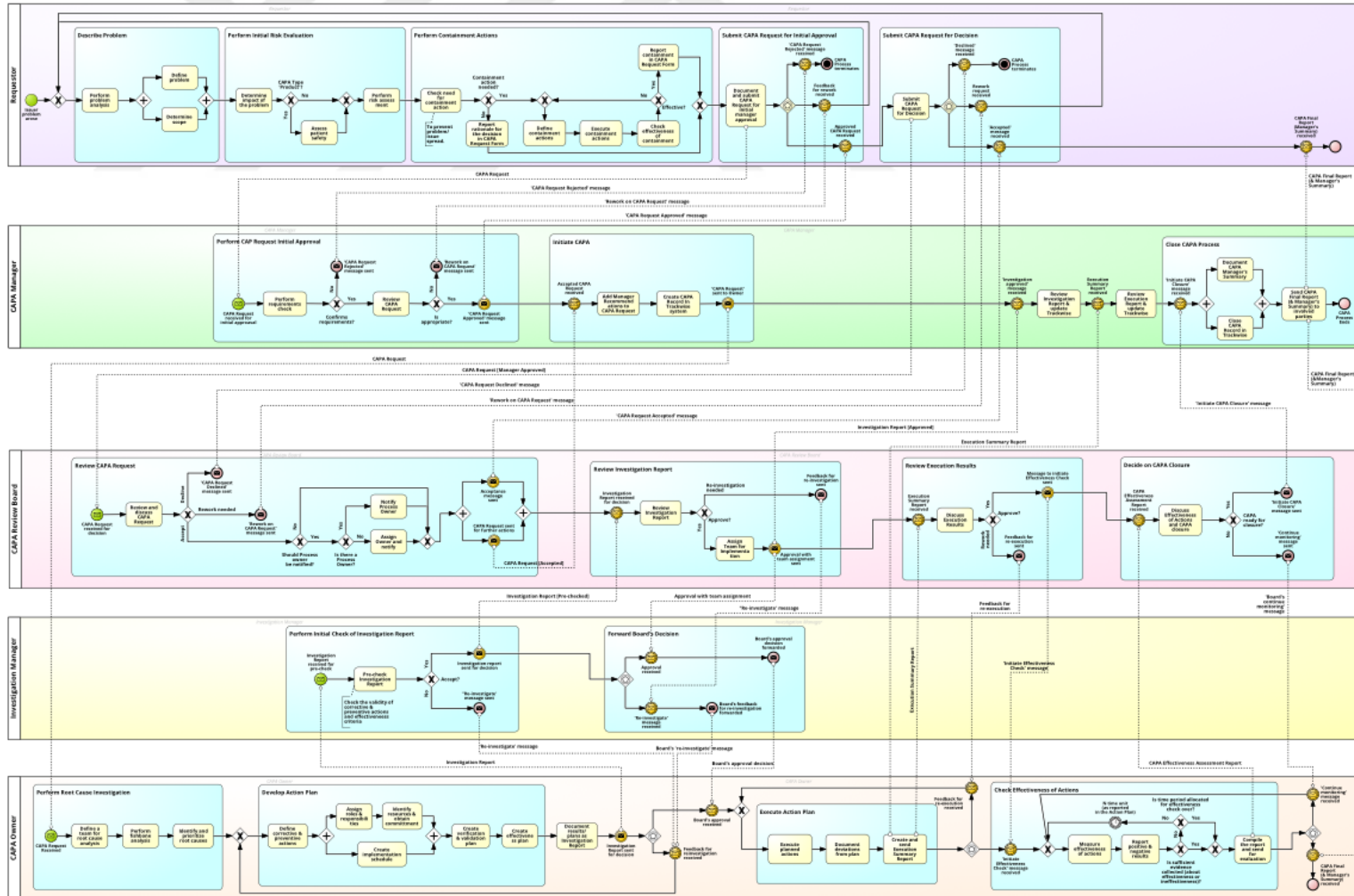

CAPA Repr3:

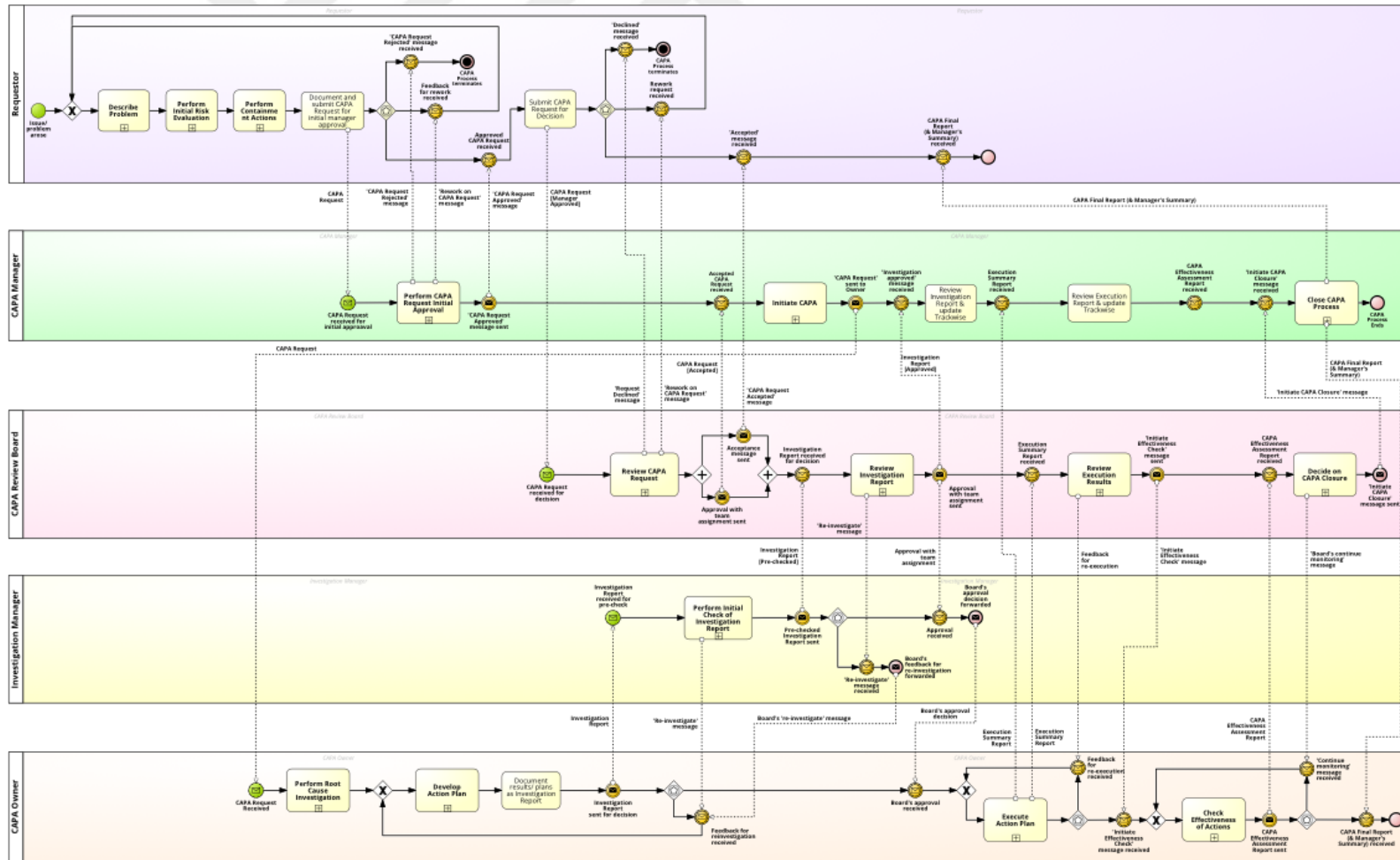

CAPA Repr3 Sub-processes 2:

CAPA Review Board → Review CAPA Request

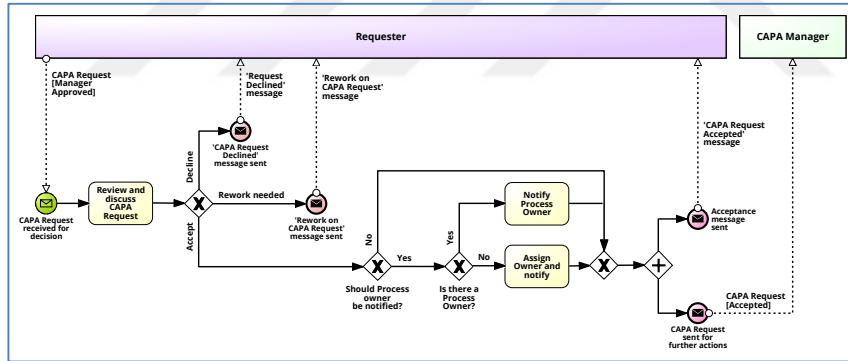

CAPA Review Board → Review Execution Results

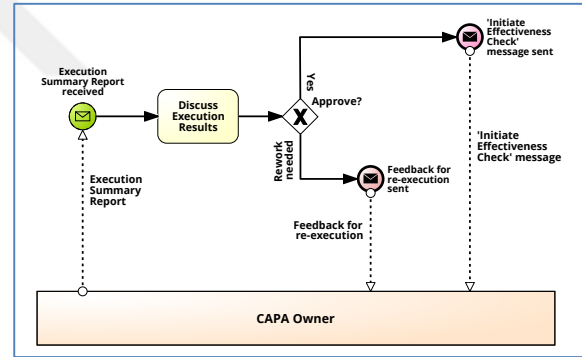

CAPA Review Board → Review Investigation Report

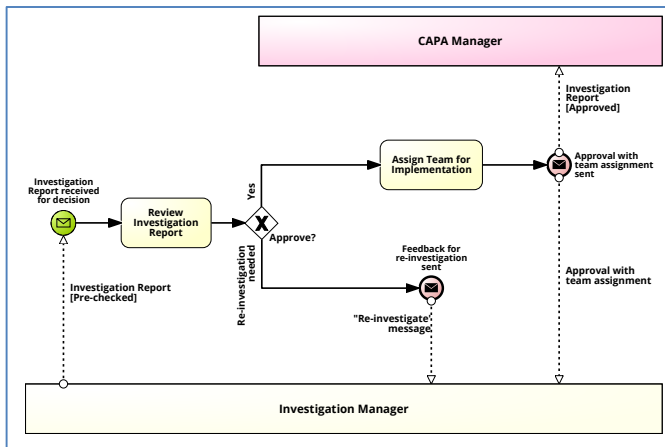

CAPA Review Board → Decide on CAPA

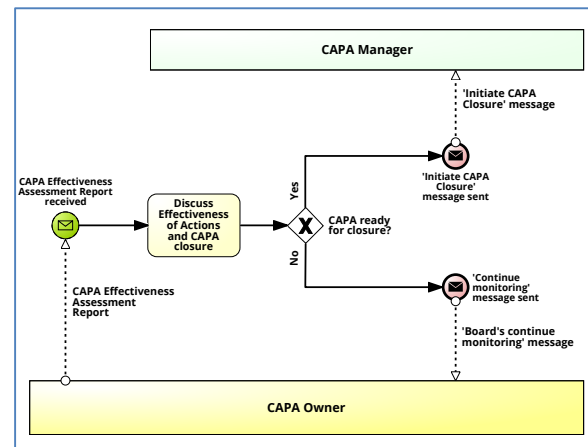

CAPA Repr3 Sub-processes 3:

Investigation Manager → Perform Initial Check of Investigation Report

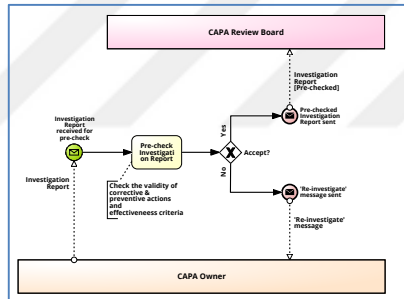

CAPA Owner → Execute Action Plan

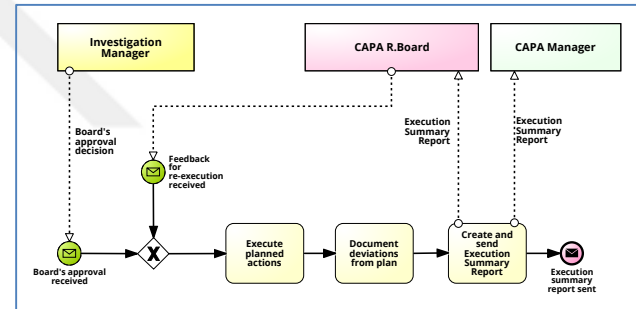

CAPA Owner → Perform Root Cause Investigation

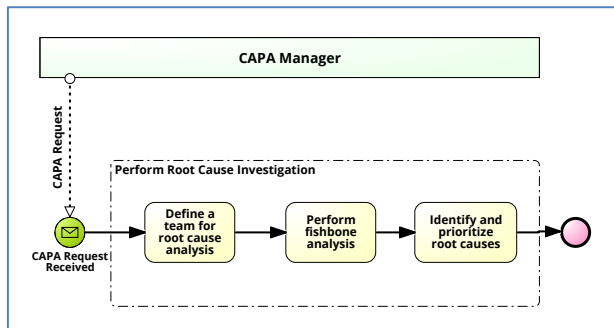

CAPA Owner → Check Effectiveness of Actions

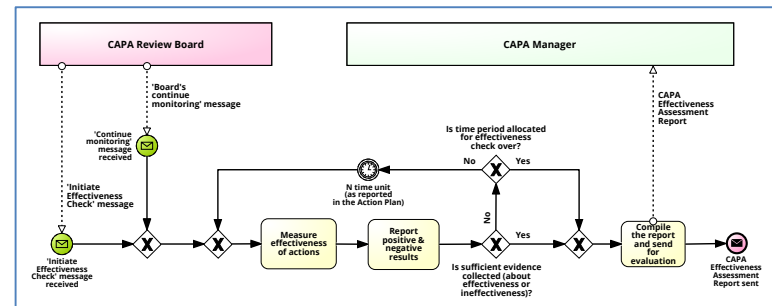

CAPA Owner → Develop Action Plan

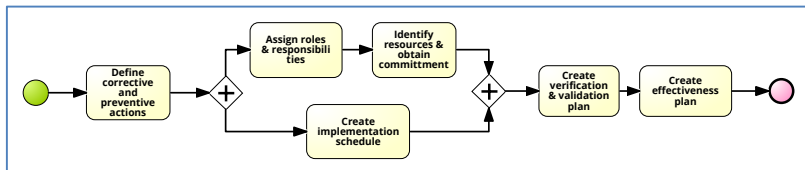

CH Repr2 (Flattened with groups):

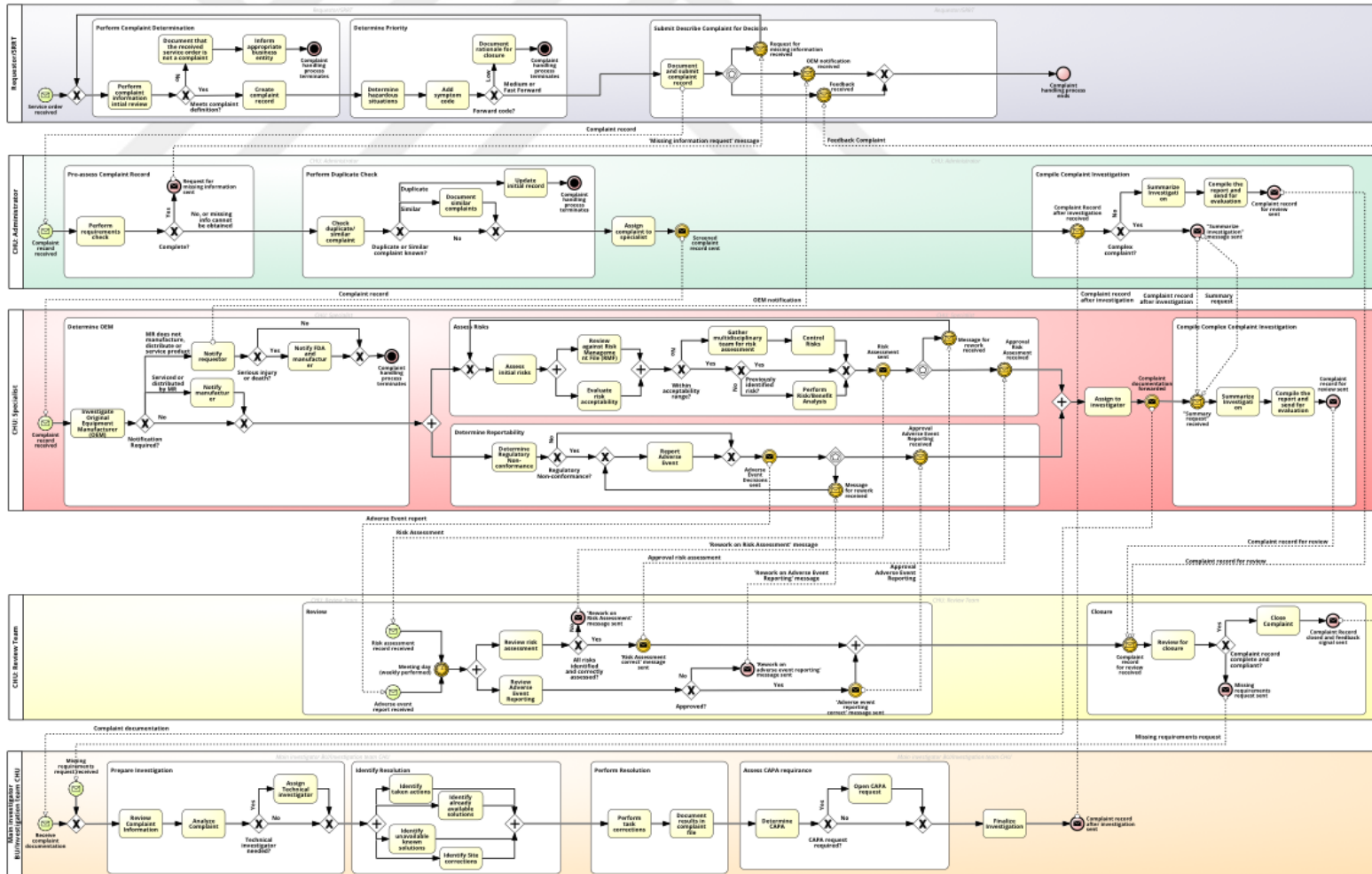

CH Repr3:

122

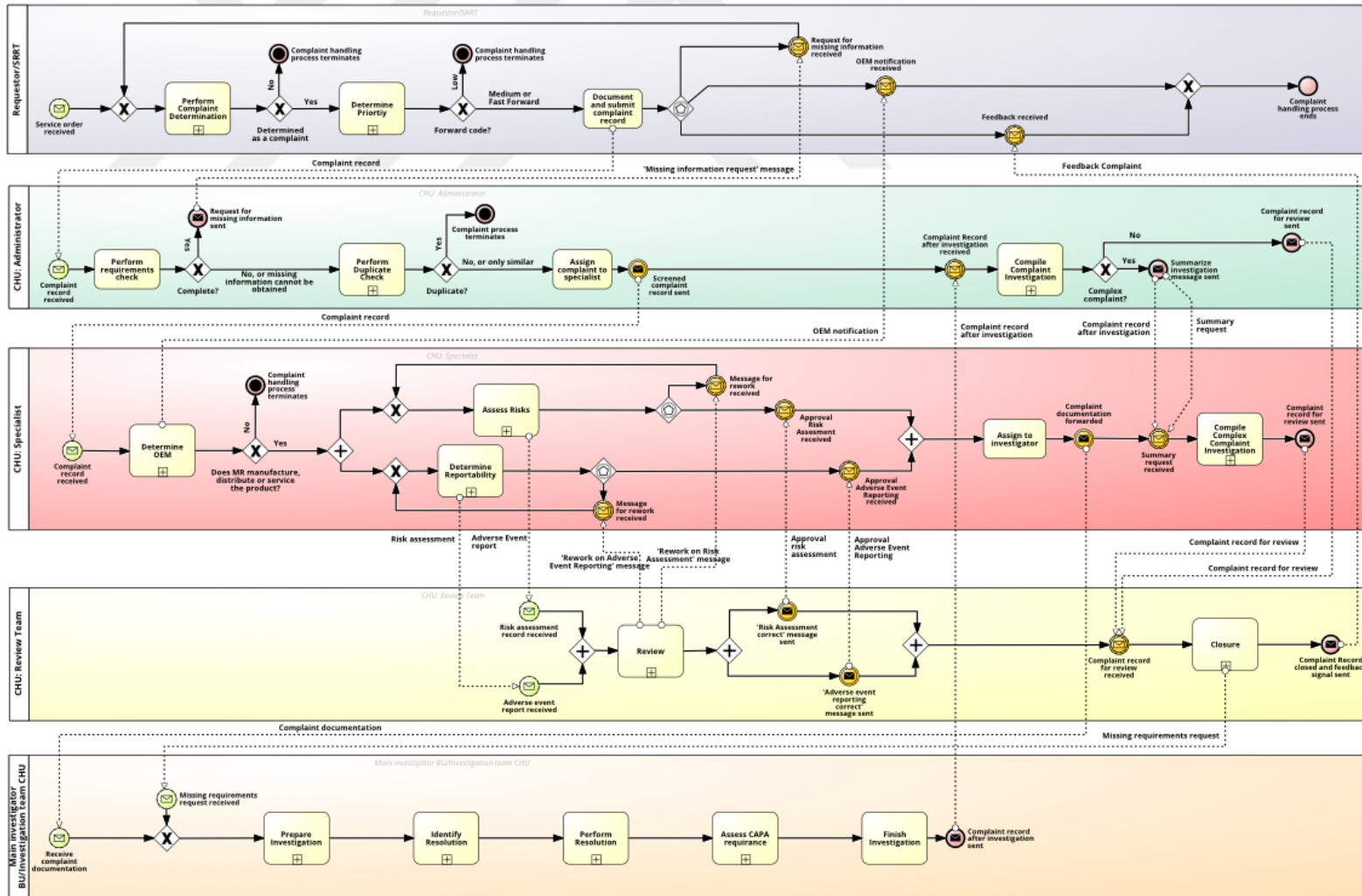

CH Repr3 Sub-processes 1:

Requestor/SRRT → Perform Complaint Determination

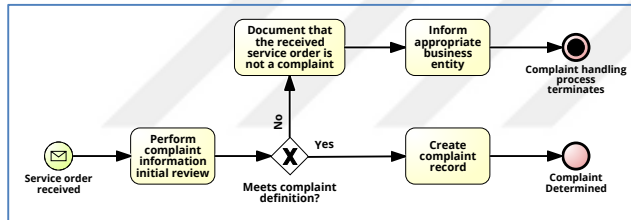

Requestor/SRRT → Determine Priority

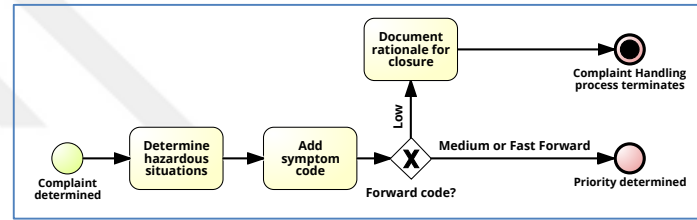

CHU: Administrator → Perform Duplicate Check

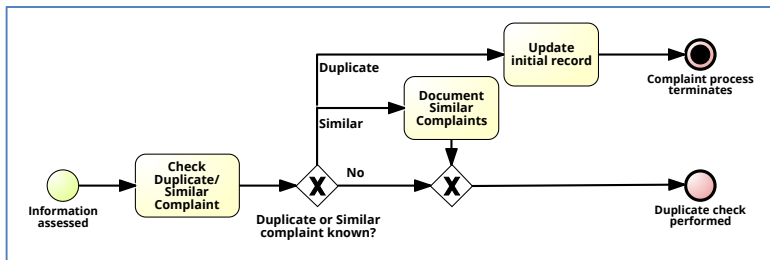

CHU: Administrator → Compile Complaint Investigation

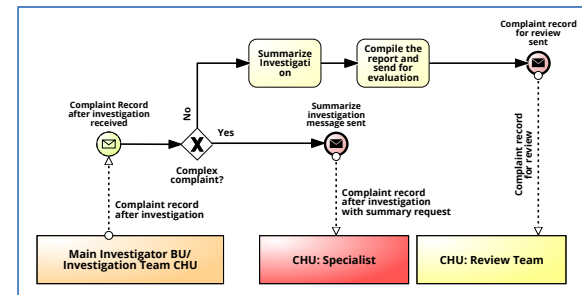

CHU: Specialist → Determine OEM

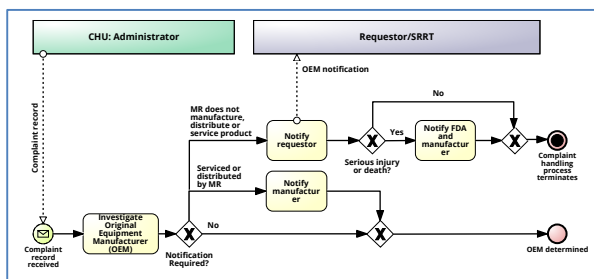

CHU: Specialist → Assess Risks

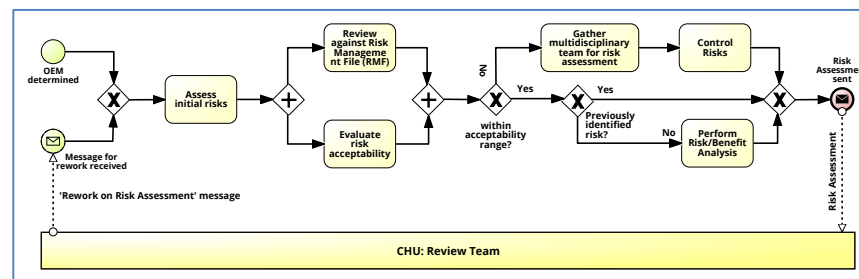

CH Repr3 Sub-processes 2:

CHU: Specialist → Determine Reportability

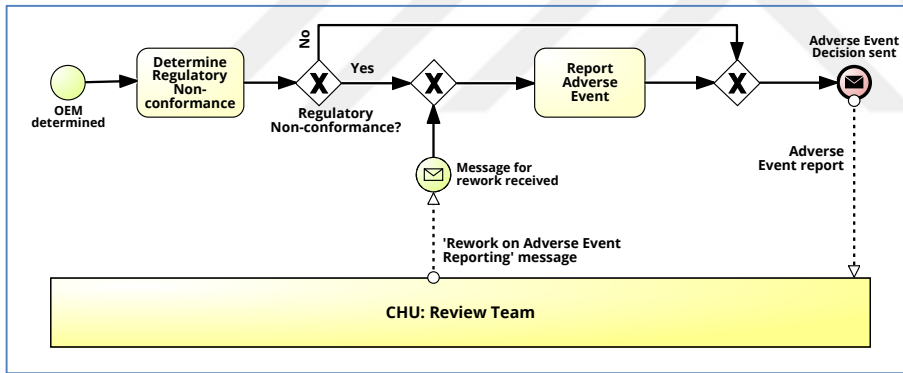

CHU: Specialist → Compile Complex Complaint Investigation

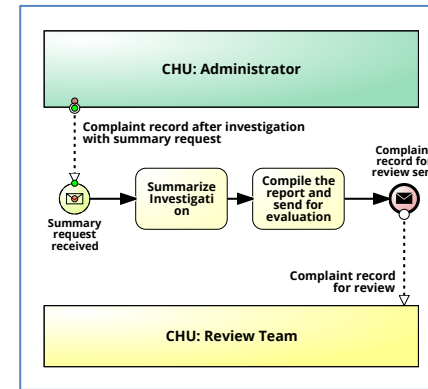

CHU: Review Team → Review

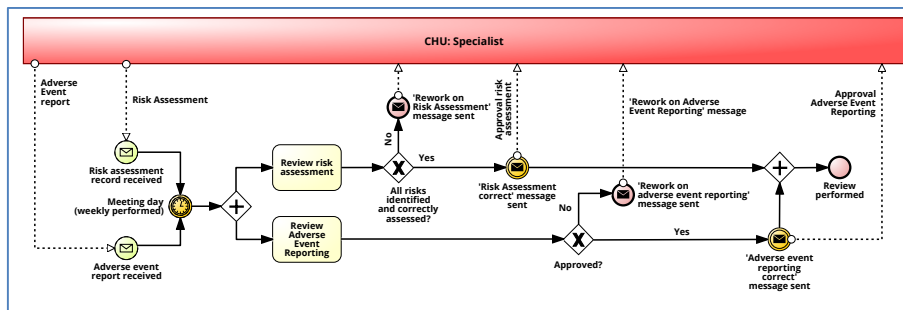

CHU: Review Team → Closure

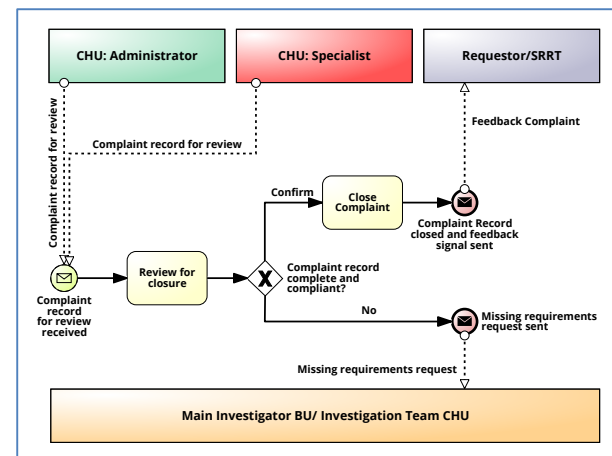

CH Repr3 Sub-processes 3:

Main investigator BU/Investigation team CHU → Prepare Investigation

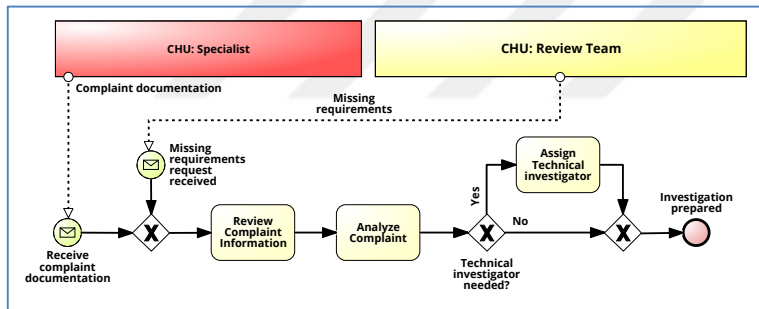

Main investigator BU/Investigation team CHU → Identify Resolution

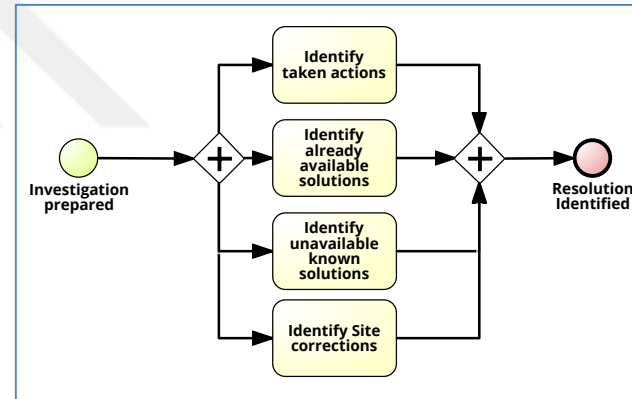

Main investigator BU/Investigation team CHU → Perform Resolution

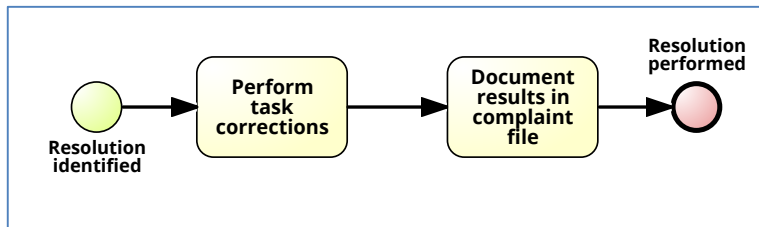

Main investigator BU/Investigation team CHU → Assess CAPA requirance

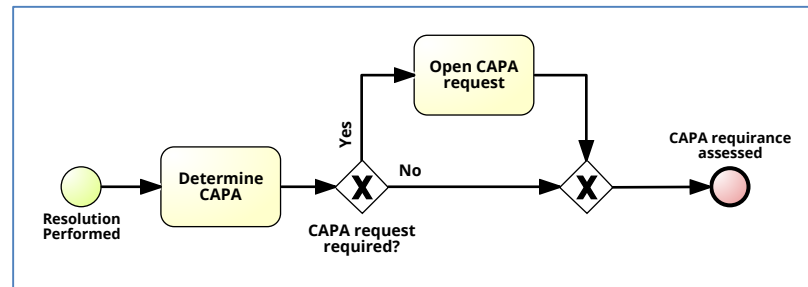

APPENDIX C: PROCESS MODELING CONVENTIONS

PROCESS MODELING CONVENTIONS

Table 35 Process modeling conventions

Subject	Modeling Convention
Activity labeling	Verb-object style is used for labeling activities. The labels should reflect the business / domain language and concepts used in the process descriptions of the organization.
Event labeling	Verb-object style in the past tense is used for labeling events. The labels should reflect the business / domain language and concepts used in the process descriptions of the organization.
Layout of activity labels	Activity labels are fitted in the rectangle symbol of activities.
Layout of event labels	Event labels are displayed on the right, above or below of the event symbol.
Layout of activities	Activities are modeled horizontally, from left to right.
Layout of events	Events are modeled horizontally, from left to right.
Layout and usage of lanes and pools	A pool is used to differentiate between roles. No lanes are included in the process models. Message flows are the only flows that connect the pools within each other.
Structuredness	Each split gateway should match a respective join gateway.
Color	<p>Start events are green.</p> <p>End events are red.</p> <p>Intermediate events are dark yellow.</p> <p>Activities are light yellow.</p> <p>Gateways are white.</p> <p>The pools are displayed in different colors.</p> <p>The sub-processes are displayed with a different color than the color of the pool in Repr2.</p>
Number of roles	Five roles are used. Otherwise, process models should be modified such that there should exist five roles.
Use of advanced BPMN	<p>The use of advanced BPMN constructs are restricted to:</p> <ul style="list-style-type: none"> • Start message event, • End message event, • Intermediate message event, • Intermediate timer event, • Event-based gateway.

APPENDIX D: QUESTIONNAIRE

QUESTIONNAIRE

Questionnaire - Welcome:

BPMResearch.net

Welcome to BPMResearch.net.

This site is currently fully dedicated to a BPM Experiment conducted by Researchers in TUE IS and METU.

Please follow [this link](#) to the experiment.



BPMResearch.net © 2014-2016, TU/e, Information Systems Group

Questionnaire - User ID:

The screenshot shows a web interface with the TU/e logo at the top. Below the logo, it says 'MIDDLE EAST TECHNICAL UNIVERSITY' and 'TU/e Technische Universiteit Eindhoven University of Technology'. The main content area contains the following text:

Dear Participant,

Thank you for your participation in this study. Your contribution is valuable for our on-going research on business process modeling.

The questionnaire may take about 1 hour to complete, but there is no time-limitation.

- The time you spend for answering each question is recorded for research purposes.

- The results of this participation will not be released in any individually identifiable form. By participating in this experiment, you agree to the use of the data you provide for research purposes.

Please do NOT use any book, notes, or other material other than those that you are provided with (if any) for the experiment.

Please enter your USER ID provided to you and click '**Next**' to continue.

User ID:

BPMResearch.net © 2014-2016, TUE IS BPM Research Group

Next >>

Questionnaire - Parts:

0%  100%

Introduction

In this questionnaire, you are expected to go through **5 parts**:

- Part 1.** Demographics and your experience in process modeling in general.
- Part 2.** A short introduction to the process modeling notation of BPMN 2.0 (business process model and notation).
- Part 3.** A test with 15 questions on the BPMN 2.0.
- Part 4.** A set of 9 questions about a particular process model that you will be given.
- Part 5.** Another set of 9 questions about a second process model.

After parts 4 and 5, you will be asked to express your opinion about the models that you have seen.
Please click Next to continue.

Next >>

Personal Factors - 1:

0%  100%

PART 1B. Personal Factors

How often do you encounter process models?

- Never
- Less than once a month
- More than once a month
- Daily

When did you first work with process models in practice?

- Never encountered a process model
- Less than a month ago
- Less than a year ago
- Less than three years ago
- More than three years ago

How would you rate your level of knowledge on process modeling?

- Not knowledgeable about
- Somewhat knowledgeable about
- Knowledgeable about
- Very knowledgeable about

How would you rate your level of knowledge on BPMN 2.0 (Business Process Model and Notation, version 2.0)?

- Not knowledgeable about
- Somewhat knowledgeable about
- Knowledgeable about
- Very knowledgeable about

Next >>

Personal Factors - 2:

0% 100%

PART 1C. Personal Factors

How familiar you would consider yourself about the process of handling large-scale problems/issues of a manufacturing company regarding its products? (More specifically, handling of issues about machineries that are in use in several customer institutions all around the world; aka. the process of Corrective Action & Preventive Action (CAPA).)

- Not at all familiar
- Slightly familiar
- Somewhat familiar
- Moderately familiar
- Extremely familiar

How familiar you would consider yourself about the process of handling customer complaints in large scale and with critical nature? aka. Complaint Handling (CH) process.)

- Not at all familiar
- Slightly familiar
- Somewhat familiar
- Moderately familiar
- Extremely familiar

Next >>

Introduction to BPMN 2.0 - 1:

0% 100%

Part2: A short introduction to BPMN 2.0

Example Model: Loan Application

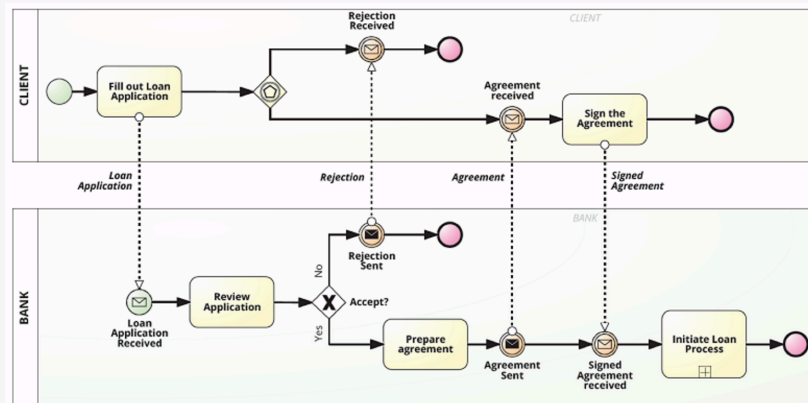

This process consists out of two roles: the "client" and the "bank". The process starts when the client needs a loan and fills out a loan application. When the client has done that, he or she will send the loan application to the bank. Subsequently, the bank receives the loan application and starts the internal process with a review of the application. The bank can either "accept" or "reject" the loan application. If the bank chooses to reject the loan application, a message with a rejection is sent to the client. The process will end there. If the bank chooses to accept the message, an agreement will be prepared and an agreement message is sent afterwards. The client receives the agreement and signs the agreement. The client sends the signed agreement back to the bank. The signed agreement is the trigger for the bank to start the sub-process "Initiate loan process". After the execution of this subprocess, the total process ends.

Introduction to BPMN 2.0 - 2:

Process Model Legend:

A process model is a picture of a process. It is very similar to a flowchart and can contain any of the following blocks:

Name	Description	Looks
Role	This long, black rectangle indicates a role within a process. All activities inside this role are considered his/her responsibilities.	
Activity	This blue square indicates some task is being performed. The description or activity of the task is mentioned on its label.	
Sub-Process	It's often useful to group some activities together and put them in a sub-process. This can be recognized by the '+' symbol on the blue square. To view the contents of a sub-process, you can simply place your cursor over the image.	
Sequence	This straight arrow indicates an order of event. The source of the arrow happened before the activity it points to can happen.	

Introduction to BPMN 2.0 - 3:

Exclusive Choice	If, at some point, a choice is made, this yellow diamond with the 'X' is used. It means that either one of the outgoing arrows will be chosen. This element can also be used to merge paths. In that case, <u>only one of the incoming arcs has to be active.</u>	
Parallel activities	This element is used to indicate the following activities can happen at the same time. This allows for parallel activities. This element can also be used to merge paths. In that case, <u>all incoming arcs have to be active.</u>	
Exclusive event-based gateway	The proceeding of the process depends on the occurrence of an event that is triggered by one of the outcomes of exclusive choices. The event is delayed or excluded until a message is received.	
Sending information	If an activity results in sending information, this element is used. It means that a message is being sent.	
Receiving information	When someone receives information, this yellow circle is being used. The difference with the previous element is that with a receiving circle the 'envelope' is white rather than black.	
Timer event	This clock shows that there is a certain delay in the process. The label with the clock shows how often something happens or how long it takes before the process proceeds.	
Message Flow	When a message is sent from one role to another, a message flow is used. This is a dashed line with a label.	

While you're answering the questions about the model, you can go back to the [process model legend](#) at any time. Please click **"Next"** to continue the questionnaire.

Theoretical Test - Start:

0% 100%

Part 3. Test on the theoretical knowledge on BPMN 2.0 Collaboration diagrams with core constructs

In the following pages, you will be asked to answer questions about the core constructs of the collaboration diagrams in BPMN (Business Process Model and Notation) 2.0.

Note that your score on this quick test will be treated anonymously for research purposes only.

The questions are of 'Yes/No' type (i.e. the expected answer is either 'yes' or 'no'). You will also be given a third option "I don't know" to pass the question. A question with this option selected will be considered as *incorrectly* answered.

Please click 'Next' to start.

Theoretical Test - 1:

0%  100%

Part 3. Personal Factors

Basic Theoretical Knowledge on BPMN 2.0

Q1. After an exclusive (XOR) gateway, at most one alternative path is executed.

- Yes
- No
- I don't know

Next >>

Theoretical Test - 2:

0%  100%

Part 3. Personal Factors

Basic Theoretical Knowledge on BPMN 2.0

Q2. Consider the process fragment given in Fig.1. The parallel (AND) gateway that connects the activities B and C indicates that these two activities should be executed at the same time.

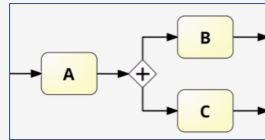

Fig.1

- Yes
- No
- I don't know

Next >>

Theoretical Test - 3:

0%  100%

Part 3. Personal Factors

Basic Theoretical Knowledge on BPMN 2.0

Q3. An exclusive (XOR) gateway can be used to model repetition.

- Yes
- No
- I don't know

Next >>

Theoretical Test - 4:

0%  100%

Part 3. Personal Factors

Basic Theoretical Knowledge on BPMN 2.0

Q4. An inclusive (OR) gateway can activate concurrent paths.

- Yes
- No
- I don't know

Next >>

Theoretical Test - 5:

0%  100%

Part 3. Personal Factors

Basic Theoretical Knowledge on BPMN 2.0

Q5. An event-based gateway (as given in Fig.2) can activate either one or multiple paths but not all.

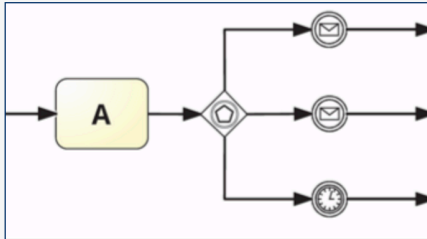

Fig.2

- Yes
- No
- I don't know

Next >>

Theoretical Test - 6:

0%  100%

Part 3. Personal Factors

Basic Theoretical Knowledge on BPMN 2.0

Q6. An event-based gateway cannot be directly followed by a message-sending event.

- Yes
- No
- I don't know

Next >>

Theoretical Test - 7:

0%  100%

Part 3. Personal Factors

Basic Theoretical Knowledge on BPMN 2.0

Q7. The process model given below (Fig.3) has syntactical errors (i.e. violates BPMN 2.0 modeling rules).

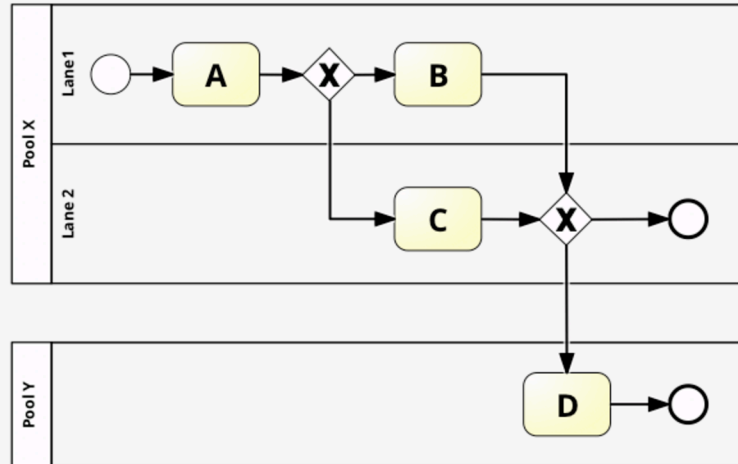

Fig.3

- Yes
- No
- I don't know

Next >>

Theoretical Test - 8:

0%  100%

Part 3. Personal Factors

Basic Theoretical Knowledge on BPMN 2.0

Q8. There is a deadlock in the process model given below in Fig.4.

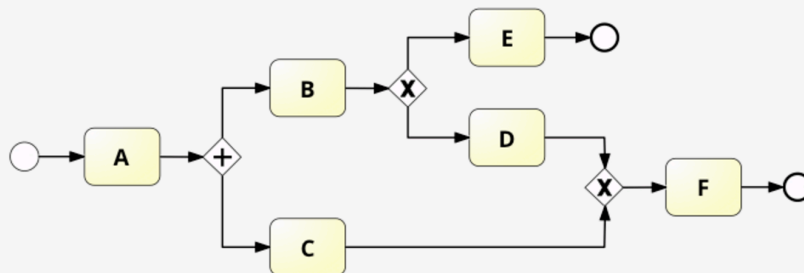

Fig.4

- Yes
- No
- I don't know

Next >>

Theoretical Test - 9:

0% 100%

Part 3. Personal Factors

Basic Theoretical Knowledge on BPMN 2.0

Q9. The problem in the process model given below (Fig.4) can be solved if the merging exclusive (XOR) gateway is replaced with merging parallel (AND) gateway.

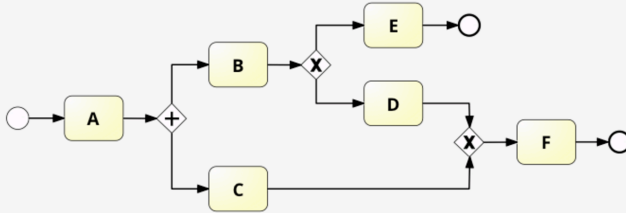

Fig.4

- Yes
- No
- I don't know

Next >>

Theoretical Test - 10:

0% 100%

Part 3. Personal Factors

Basic Theoretical Knowledge on BPMN 2.0

Q10. There are two message-receiving events in the process model given below (Fig.5).

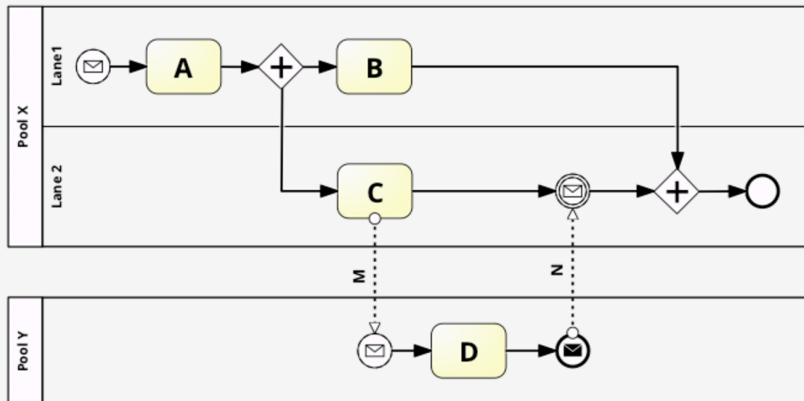

Fig.5

- Yes
- No
- I don't know

Next >>

Theoretical Test - 11:

0%  100%

Part 3. Personal Factors
Basic Theoretical Knowledge on BPMN 2.0

Q11. A message flow can connect a sub-process to another sub-process in the same pool.

Yes
 No
 I don't know

Next >>

Theoretical Test - 12:

0%  100%

Part 3. Personal Factors
Basic Theoretical Knowledge on BPMN 2.0

Q12. Fig. 6 shows a process model where the labels for the activities show (besides the activity names) the longest time for each activity to complete (in days). Accordingly, the process in Fig. 6 takes at most 9 days to complete.

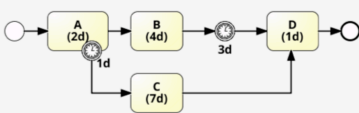

Fig. 6

Yes
 No
 I don't know

Next >>

Theoretical Test - 13:

0%  100%

Part 3. Personal Factors
Basic Theoretical Knowledge on BPMN 2.0

Q13. A sub-process cannot have another sub-process nested within.

Yes
 No
 I don't know

Next >>

Theoretical Test - 14:

0%  100%

Part 3. Personal Factors
Basic Theoretical Knowledge on BPMN 2.0

Q14. If a task has two input arcs, it is the same as if the task was preceded by a joining exclusive (XOR-join) gateway

Yes
 No
 I don't know

Next >>

Theoretical Test - 15:

0%  100%

Part 3. Personal Factors

Basic Theoretical Knowledge on BPMN 2.0

Q15. In BPMN, both *pools* and *lanes* may represent a process participant, a business unit or a software system.

- Yes
- No
- I don't know

Next >>

Theoretical Test - End:

0%  100%

End of the Part 3

Please click 'next' to proceed.

Next >>

Understandability Questions - Start:

0%  100%

Part 4 and 5. Questions about Process Models

In the last two parts of the experiment, you will be given nine multiple-choice questions (to be chosen from 5 options) about two process models consecutively.

The last option will always be: " - *I don't know*", in which - when selected- the question will be considered as incorrectly answered.

Before you proceed please make sure that you have received the message/handout that indicates ***your questionnaire type***.

If you know your questionnaire type, please click 'next' to continue.

Next >>

Type Selection:

0% 100%

Part 4 and 5. Questions about a Process Model

Questionnaire Type

Please check carefully the messages/documents that you have received about the questionnaire type, and select the correct type from the choices given below.

- A
- B
- C
- D
- E
- F

Next >>

CAPA Process:

0% 100%

Corrective & Preventive Action (CAPA) Process

When a problem/issue occurs with a product in use, the customer company may contact the customer service, which may eventually contact the headquarters if the problem/issue deemed major. If the problem is considered to have large impact for the business or the customer, the headquarter initiates the Corrective & Preventive Action (CAPA) process.

When the decision to initiate is given, a requester for the CAPA is assigned on behalf of the customer. The requestor gathers all initial information and subsequently submits a CAPA request. A CAPA review board meets weekly to decide on CAPA requests and monitors progress of current CAPA's. Once a CAPA request is approved, a subject matter expert (SME) is appointed as a dedicated CAPA Owner. This CAPA Owner becomes responsible for performing the root cause analysis and developing actions to mitigate or remove the root cause. At certain control points, the CAPA Review Board provides a decision to either progress to the next phase of the CAPA or ask for rework. After sufficient evidence has been provided that a certain solution solved the root cause of the problem, the CAPA can be closed.

In the pages that follow, you will be asked questions about the process. For each question, you will be referred to the printed version of the process model(s) that were provided to you.

Please take a look at the process model(s) and click 'next' to continue when ready.

Next >>

CAPA Process - Understandability Questions - 1:

0% 100%

Q1. If the rationale for not performing containment actions is reported in the CAPA Request Form for a case, then how many times the Define containment actions activity must have been executed for the same case?

- Zero or more times
- Zero times and not more than that
- At most once
- At least once
- I don't know

Next >>

CAPA Process - Understandability Questions - 2:

0%  100%

Q2. Who will know that the CAPA Request is accepted after a positive opinion of the CAPA Review Board?

- Only CAPA Manager
- Only CAPA Owner
- Only Requester
- Both CAPA Manager and the Requester
- I don't know

Next >>

CAPA Process - Understandability Questions - 3:

0%  100%

Q3. If the planned actions for the CAPA are executed, who will receive the Execution Summary Report?

- Only CAPA Manager
- Only CAPA Review Board
- Either CAPA Manager or CAPA Review Board
- Both CAPA Manager and CAPA Review Board
- I don't know

Next >>

CAPA Process - Understandability Questions - 4:

0%  100%

Q4. How does the CAPA Owner receive the CAPA Review Board's 're-investigate' message?

- Through the Investigation Manager
- Through the CAPA Manager
- Directly from the CAPA Review Board
- CAPA Owner does not receive such a message
- I don't know

Next >>

CAPA Process Understandability Questions - 5:

0%  100%

Q5. Which messages are exchanged between the CAPA Requester and the CAPA Owner?

- CAPA Request
- CAPA Final Report (& Manager's Summary)
- All of above
- None of above
- I don't know

Next >>

CAPA Process - Understandability Questions - 6:

0%  100%

Q6. After measuring the effectiveness of actions for a case, under what condition should the CAPA Owner NOT send the CAPA Effectiveness Assessment Report for evaluation?

- When waiting time of N time unit is still not over.
- Only when there is no sufficient evidence collected (about the effectiveness or ineffectiveness of the actions).
- When there is no sufficient evidence collected (about the effectiveness or ineffectiveness of the actions) and the time period allocated for the effectiveness check is not over.
- Only when the time period allocated for the effectiveness check is not over.
- I don't know

Next >>

CAPA Process - Understandability Questions - 7:

0%  100%

Q7. Who execute(s) the final activity in the CAPA process for an accepted CAPA case?

- Requester and CAPA Owner at the same time
- Requester
- CAPA Owner
- CAPA Manager
- I don't know

Next >>

CAPA Process - Understandability Questions - 8:

0%  100%

Q8. If the CAPA Review Board receives an Investigation Report, which was rejected by the board in the first time, how many times should this report have been pre-checked by the Investigation Manager?

- Exactly Zero times
- Exactly Once
- Exactly Two times
- Two or more times
- I don't know

Next >>

CAPA Process - Understandability Questions - 9:

0%  100%

Q9. If the CAPA Owner is performing a root-cause investigation for a case, which of the following activities of the CAPA Manager must have been performed only once for the same case?

- Sending 'CAPA Request Rejected' message
- Sending 'Rework on CAPA Request' message
- Sending CAPA Request Approved message
- None of above
- I don't know

Next >>

CAPA Process - Understandability Questions - End:

0% 100%

--- End of Part 4 Process 1---

Please continue by clicking 'Next'.

Next >>

CAPA Process - Perceived Understandability Questions - 1:

0% 100%

In the previous part, you were given a process model that is modeled using a particular representation approach. This part of the questionnaire will ask your opinion about this representation approach.

For each of the following statements, please indicate to what extent you agree with them by clicking the circle that corresponds with your opinion.

	Strongly disagree	Moderately disagree	Somewhat disagree	Neutral	Somewhat agree	Moderately agree	Strongly agree
Business process models represented in this way would be difficult for users to understand.	<input type="radio"/>	<input type="radio"/>	<input type="radio"/>	<input type="radio"/>	<input type="radio"/>	<input type="radio"/>	<input type="radio"/>
I think this presentation approach provides an effective solution to the problem of representing business process models.	<input type="radio"/>	<input type="radio"/>	<input type="radio"/>	<input type="radio"/>	<input type="radio"/>	<input type="radio"/>	<input type="radio"/>
Using this type of process models would make it more difficult to communicate business processes to end-users.	<input type="radio"/>	<input type="radio"/>	<input type="radio"/>	<input type="radio"/>	<input type="radio"/>	<input type="radio"/>	<input type="radio"/>
Overall, I found the business process model in this experiment to be useful.	<input type="radio"/>	<input type="radio"/>	<input type="radio"/>	<input type="radio"/>	<input type="radio"/>	<input type="radio"/>	<input type="radio"/>

CAPA Process - Perceived Understandability Questions - 2:

For each of the following statements, please indicate to what extent you agree with them by clicking the circle that corresponds with your opinion.

	Strongly disagree	Moderately disagree	Somewhat disagree	Neutral	Somewhat agree	Moderately agree	Strongly agree
Learning to use this way of modeling business processes would be easy for me.	<input type="radio"/>	<input type="radio"/>	<input type="radio"/>	<input type="radio"/>	<input type="radio"/>	<input type="radio"/>	<input type="radio"/>
I found the way the process is represented as unclear and difficult to understand.	<input type="radio"/>	<input type="radio"/>	<input type="radio"/>	<input type="radio"/>	<input type="radio"/>	<input type="radio"/>	<input type="radio"/>
It would be easy for me to become skillful at using this way of modeling business processes.	<input type="radio"/>	<input type="radio"/>	<input type="radio"/>	<input type="radio"/>	<input type="radio"/>	<input type="radio"/>	<input type="radio"/>
Overall, I found this way of modeling business processes difficult to use.	<input type="radio"/>	<input type="radio"/>	<input type="radio"/>	<input type="radio"/>	<input type="radio"/>	<input type="radio"/>	<input type="radio"/>

CAPA Process - Perceived Understandability Questions - 3:

For each of the following statements, please indicate to what extent you agree with them by clicking the circle that corresponds with your opinion.

	Strongly disagree	Moderately disagree	Somewhat disagree	Neutral	Somewhat agree	Moderately agree	Strongly agree
I would definitely not use this method to model business processes.	<input type="radio"/>	<input type="radio"/>	<input type="radio"/>	<input type="radio"/>	<input type="radio"/>	<input type="radio"/>	<input type="radio"/>
I would intend to use this way of modeling business processes in preference to another modeling approach, if I have to work with business process models in the future.	<input type="radio"/>	<input type="radio"/>	<input type="radio"/>	<input type="radio"/>	<input type="radio"/>	<input type="radio"/>	<input type="radio"/>

Please click the next button to continue.

Next >>

CH Process:

0% 100%

Complaint Handling (CH) Process

When a complaint arises with a product in use, the Complaint Handling Unit (CHU) will be notified. When all the needed information is complete, the assigned Complaint Handling Specialist will assess the risks that might be caused by the complaint. The Complaint Handling Specialist is also responsible for the Adverse Event Coordinator role. He or she assures that regulatory non-conformance issues and reporting, attributed to the complaint, are handled well. The Complaint Handling Review Team will monitor all the activities that have to be controlled in order to execute the Complaint Investigation in a comprehensive way. The investigation will be within the responsibility of the main Investigator within the Business Unit (BU) where the complaint originates, or within the responsibility of the CHU. This depends on the technical domain knowledge accompanied to the resolution of the complaint. In the end, the complaint might need a root-cause analysis or has to evolve into a CAPA request before closure. Just as well, when the complaint has been handled without any further necessary action, the complaint can be filed and closed.

In the pages that follow, you will be asked questions about the process. For each question, you will be referred to the printed version of the process model(s) that were provided to you.

Please take a look at the process model(s) and click 'next' to continue when ready.

Next >>

CH Process - Understandability Questions - 1:

0%  100%

Q1. If the Requestor/SRRT receives a request for missing information, how many times must the CHU administrator have sent a request for missing information?

- Zero or more times
- Zero times and not more than that
- At most once
- At least once
- I don't know

Next >>

CH Process - Understandability Questions - 2:

0%  100%

Q2. What happens to the submitted service order when it does not meet the definition of a complaint?

- The CHU Administrator sends a request for missing information
- After documentation and informing the appropriate business entity, the process ends
- The complaint process terminates without further actions
- Hazardous situations have to be considered before the case can be closed
- I don't know

Next >>

CH Process - Understandability Questions - 3:

0%  100%

Q3. Who will be notified if the complaint concerns a product which is not manufactured, nor distributed or serviced by MR with a serious death or injury ?

- Only the Requestor/SRRT of the complaint receives a message
- The Requestor/SRRT and the CHU Review Team
- The Requestor/SRRT of the complaint, the OEM manufacturer, and the FDA
- The FDA, and the OEM manufacturer
- I don't know

Next >>

CH Process - Understandability Questions - 4:

0%  100%

Q4. How does the CHU Specialist receive the complaint record after the investigation team finishes the investigation?

- Directly from the CHU Review Team
- Through the CHU Administrator
- Directly from the Investigation Team
- The CHU Specialist does not receive the complaint record
- I don't know

Next >>

CH Process - Understandability Questions - 5:

0%  100%

Q5. Who is responsible for performing "task corrections" during the investigation of the complaint?

- Main Investigator/Investigation Team
- CHU Specialist
- CHU Review Team
- None of the above
- I don't know

Next >>

CH Process - Understandability Questions - 6:

0%  100%

Q6. After the CHU specialist has completed the OEM investigation, what actions have to be completed before the complaint can be assigned to the investigator?

- Only the Risk Assessment has to be approved before the assignment to an investigator can take place
- Only the control of risks, and the risk/benefit analysis have to be completed before the assignment to an investigator can take place
- Only the Risk Assessment and the Adverse Event Reporting have to be approved before the assignment to an investigator can take place
- Only the review against Risk Management File (RMF) has to be completed before the assignment to an investigator can take place
- I don't know

Next >>

CH Process - Understandability Questions - 7:

0%  100%

Q7. Which of the following messages is exchanged between the Main Investigator/Investigation Team and the CHU Administrator?

- The Risk Assessment
- The Complaint feedback
- Missing requirements request
- None of the above
- I don't know

Next >>

CH Process - Understandability Questions - 8:

0%  100%

Q8. Who will know that the Adverse Event Reporting is approved by the CHU Review Team??

- The CHU Specialist
- Main Investigator/ Investigation Team
- Both CHU Specialist and the Main Investigator/ Investigation Team
- None of the above
- I don't know

Next >>

CH Process - Understandability Questions - 9:

0%  100%

Q9. If the Risk Assessment conducted by the CHU Specialist has been approved by the CHU Review Team, how often has the CHU Specialist performed a Risk/Benefit Analysis?

- Zero or more times
- Zero times and not more than that
- At most once
- At least once
- I don't know

Next >>

CH Process - Understandability Questions - End:

0%  100%

--- End of Part 5 Process 2---

Please continue by clicking 'Next'.

Next >>

CH Process - Perceived Understandability Questions - 1:

0%  100%

In the previous part, you were given a process model that is modeled using a particular representation approach. This part of the questionnaire will ask your opinion about this representation approach.

For each of the following statements, please indicate to what extent you agree with them by clicking the circle that corresponds with your opinion.

	Strongly disagree	Moderately disagree	Somewhat disagree	Neutral	Somewhat agree	Moderately agree	Strongly agree
Business process models represented in this way would be difficult for users to understand.	<input type="radio"/>	<input type="radio"/>	<input type="radio"/>	<input type="radio"/>	<input type="radio"/>	<input type="radio"/>	<input type="radio"/>
I think this presentation approach provides an effective solution to the problem of representing business process models.	<input type="radio"/>	<input type="radio"/>	<input type="radio"/>	<input type="radio"/>	<input type="radio"/>	<input type="radio"/>	<input type="radio"/>
Using this type of process models would make it more difficult to communicate business processes to end-users.	<input type="radio"/>	<input type="radio"/>	<input type="radio"/>	<input type="radio"/>	<input type="radio"/>	<input type="radio"/>	<input type="radio"/>
Overall, I found the business process model in this experiment to be useful.	<input type="radio"/>	<input type="radio"/>	<input type="radio"/>	<input type="radio"/>	<input type="radio"/>	<input type="radio"/>	<input type="radio"/>

CH Process - Perceived Understandability Questions - 2:

For each of the following statements, please indicate to what extent you agree with them by clicking the circle that corresponds with your opinion.

	Strongly disagree	Moderately disagree	Somewhat disagree	Neutral	Somewhat agree	Moderately agree	Strongly agree
Learning to use this way of modeling business processes would be easy for me.	<input type="radio"/>	<input type="radio"/>	<input type="radio"/>	<input type="radio"/>	<input type="radio"/>	<input type="radio"/>	<input type="radio"/>
I found the way the process is represented as unclear and difficult to understand.	<input type="radio"/>	<input type="radio"/>	<input type="radio"/>	<input type="radio"/>	<input type="radio"/>	<input type="radio"/>	<input type="radio"/>
It would be easy for me to become skillful at using this way of modeling business processes.	<input type="radio"/>	<input type="radio"/>	<input type="radio"/>	<input type="radio"/>	<input type="radio"/>	<input type="radio"/>	<input type="radio"/>
Overall, I found this way of modeling business processes difficult to use.	<input type="radio"/>	<input type="radio"/>	<input type="radio"/>	<input type="radio"/>	<input type="radio"/>	<input type="radio"/>	<input type="radio"/>

CH Process - Perceived Understandability Questions - 3:

For each of the following statements, please indicate to what extent you agree with them by clicking the circle that corresponds with your opinion.

	Strongly disagree	Moderately disagree	Somewhat disagree	Neutral	Somewhat agree	Moderately agree	Strongly agree
I would definitely not use this method to model business processes.	<input type="radio"/>	<input type="radio"/>	<input type="radio"/>	<input type="radio"/>	<input type="radio"/>	<input type="radio"/>	<input type="radio"/>
I would intend to use this way of modeling business processes in preference to another modeling approach, if I have to work with business process models in the future.	<input type="radio"/>	<input type="radio"/>	<input type="radio"/>	<input type="radio"/>	<input type="radio"/>	<input type="radio"/>	<input type="radio"/>

Please click the next button to continue.

Next >>

Questionnaire - End:

0%  100%

Thank you for your participation!

If you would like to receive further information about the experiment and your own score, please send an email to "ahmetdikici@gmail.com".

You may now close the browser window.

BPMResearch.net © 2014-2016, TUE IS BPM Research Group



APPENDIX E: ASSUMPTIONS

ASSUMPTIONS

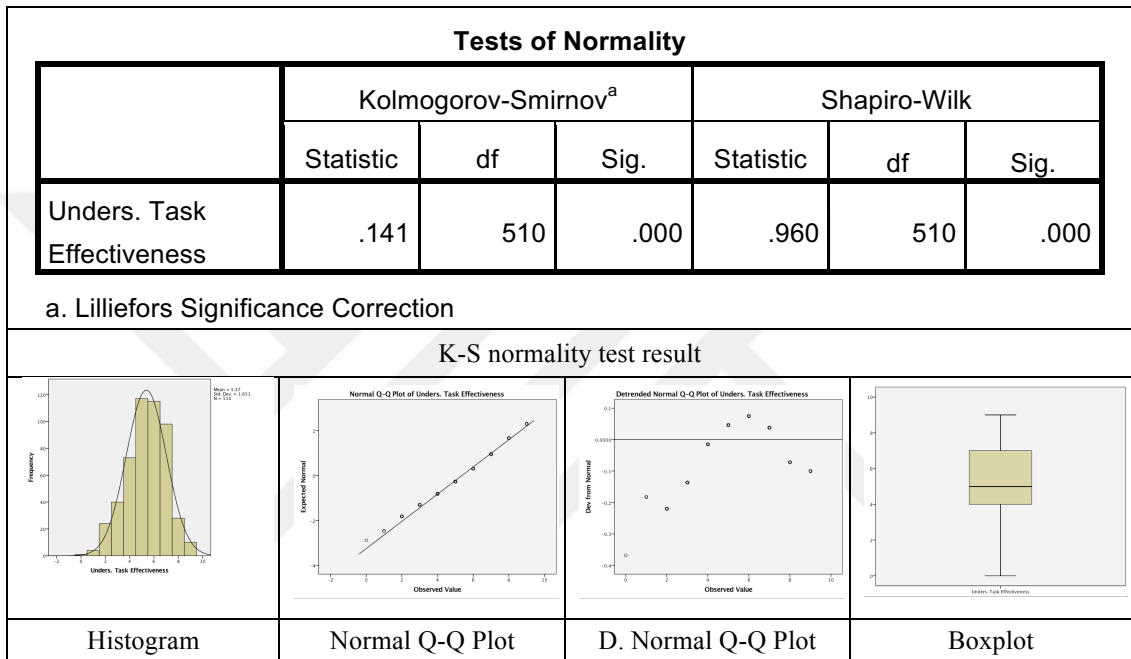

Figure 23 Normality test results for understandability task effectiveness

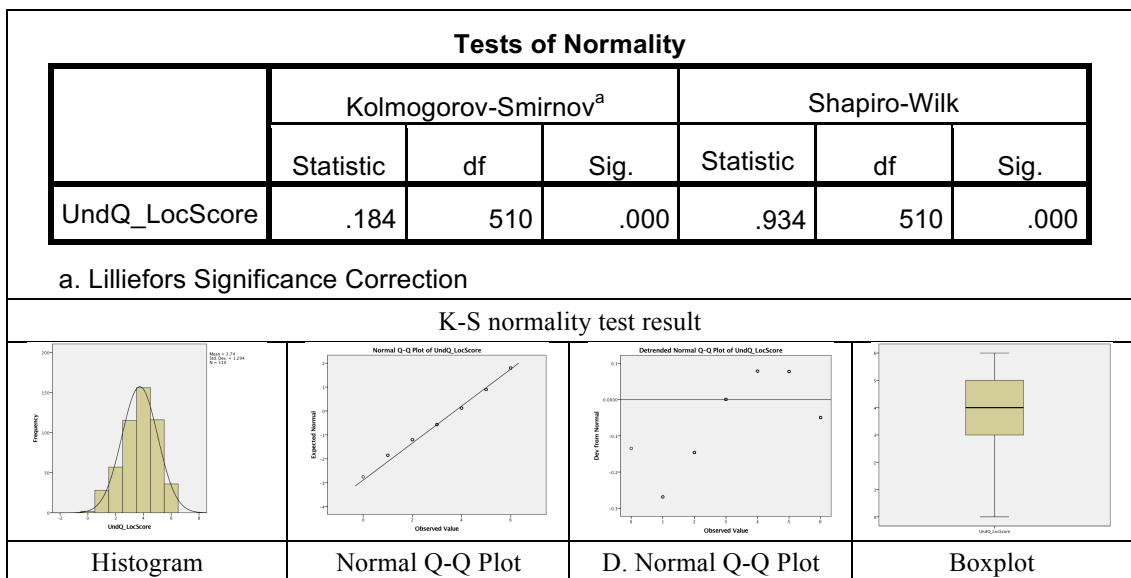

Figure 24 Normality test results for understandability task effectiveness (local)

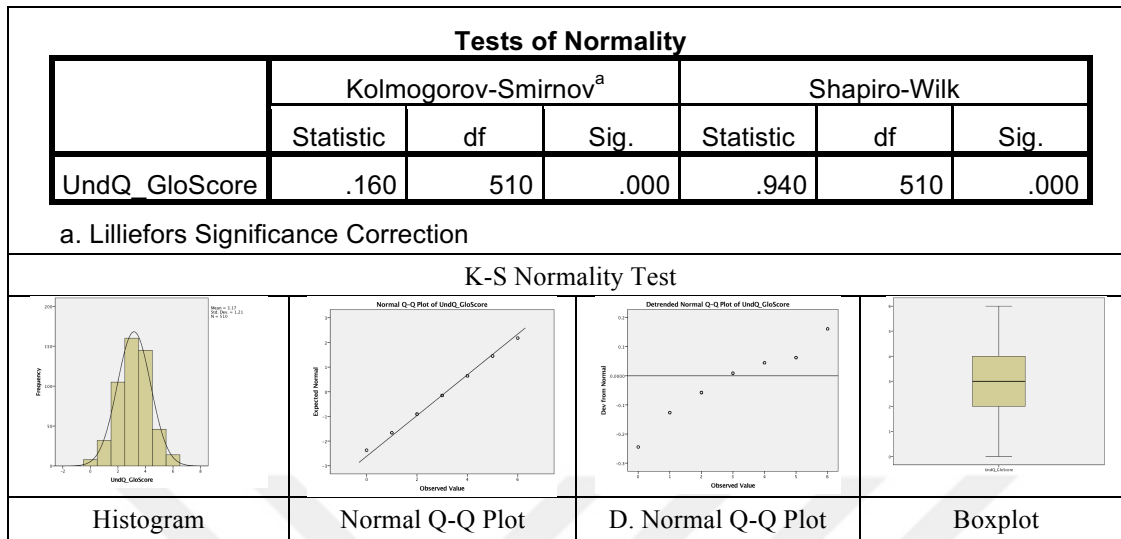

Figure 25 Normality test results for understandability task effectiveness (global)

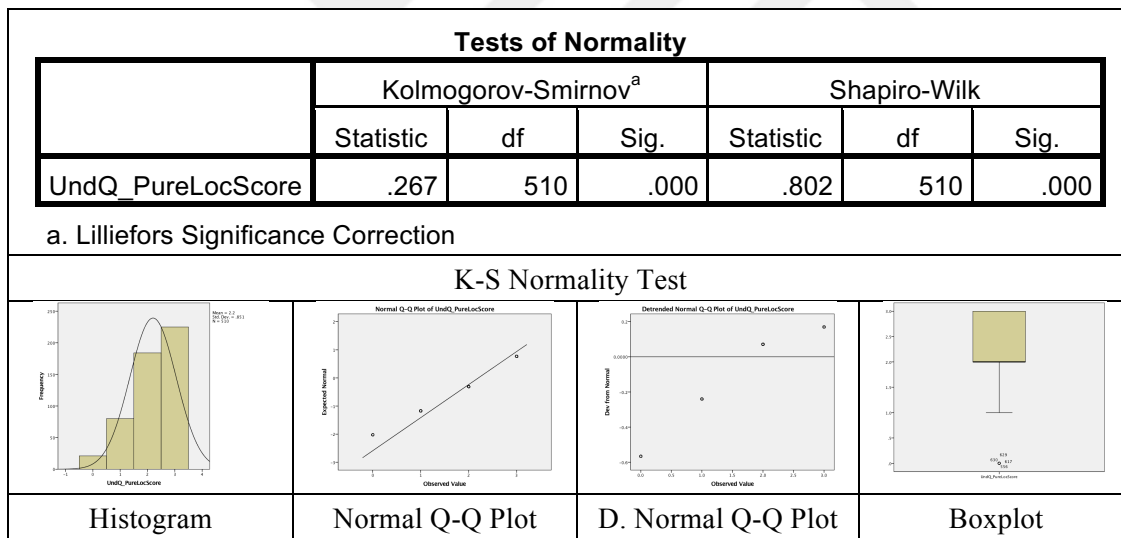

Figure 26 Normality test results for understandability task effectiveness (local-only)

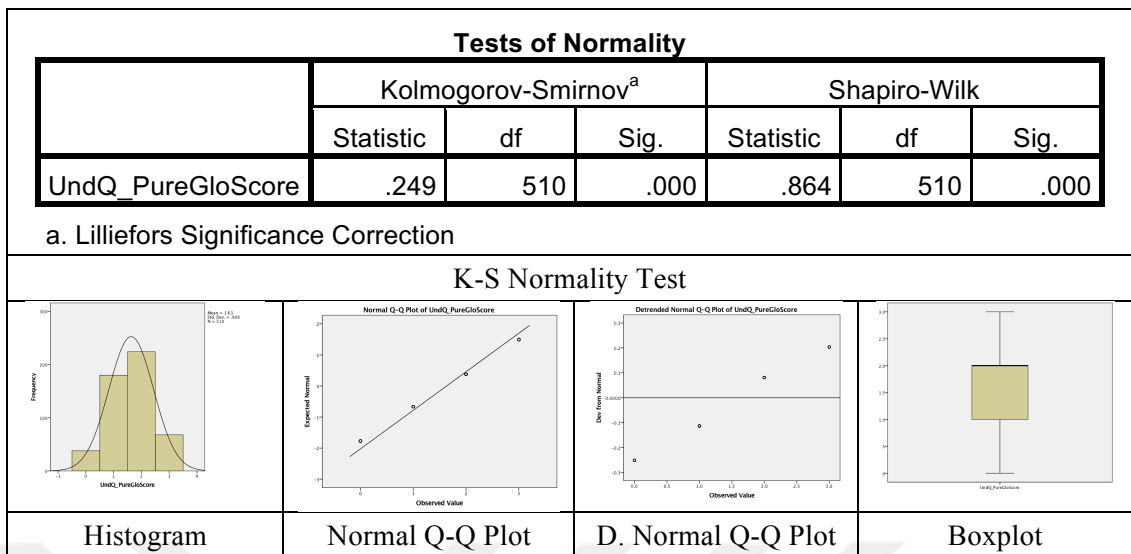

Figure 27 Normality test results for understandability task effectiveness (global-only)

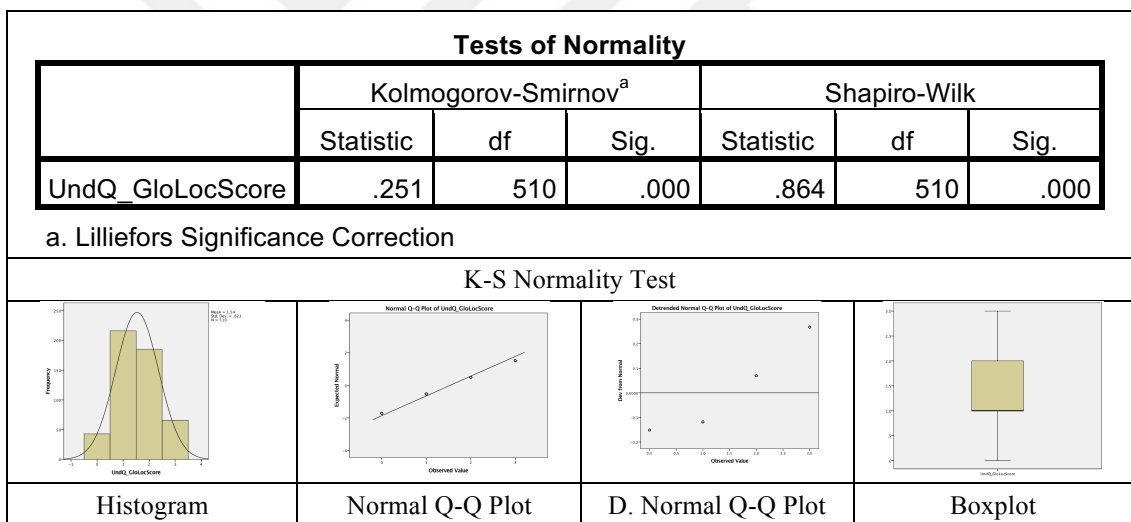

Figure 28 Normality test results for understandability task effectiveness (global and local)

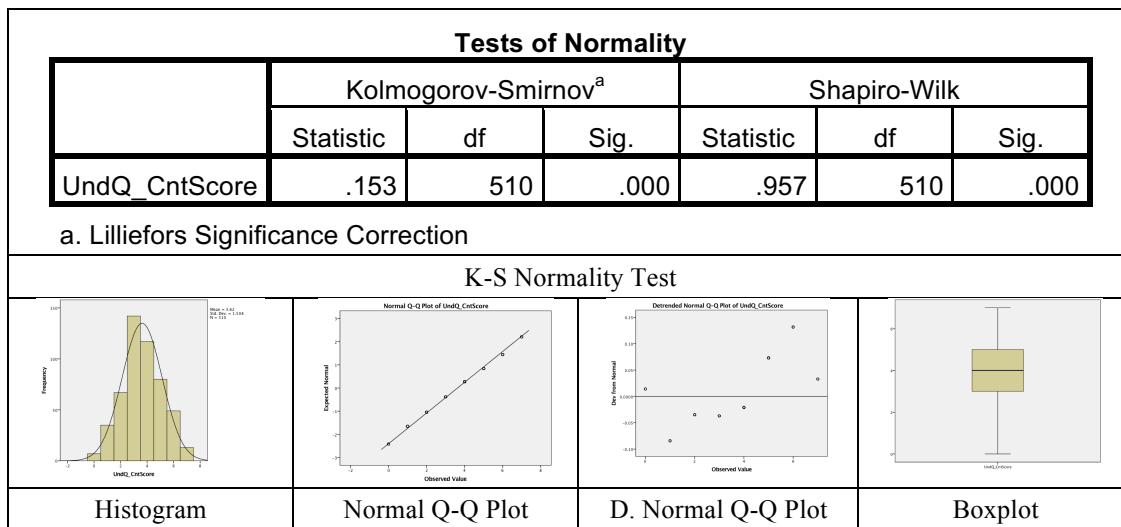

Figure 29 Normality test results for understandability task effectiveness (control flow)

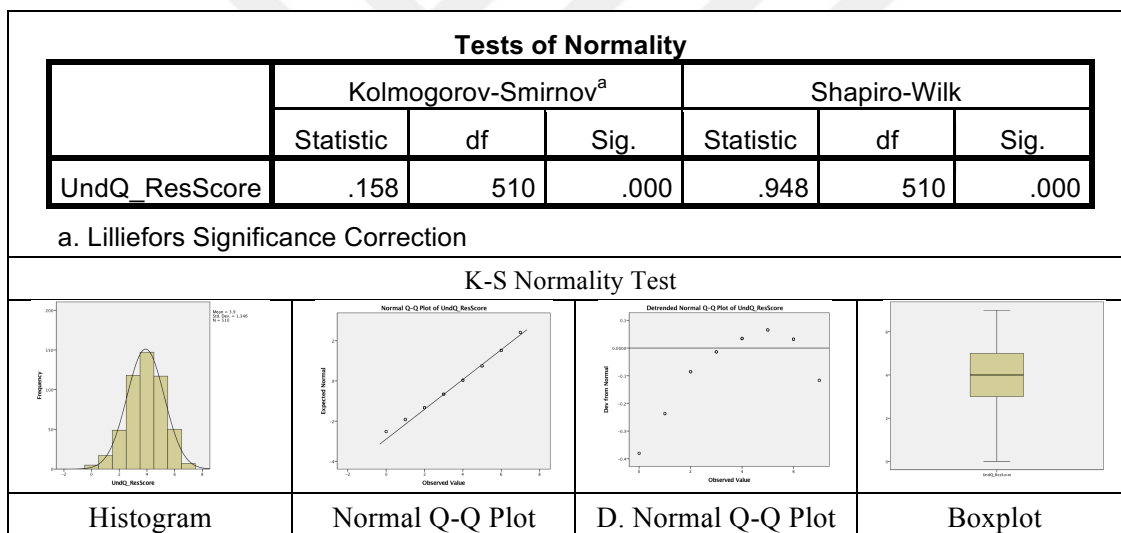

Figure 30 Normality test results for understandability task effectiveness (resource)

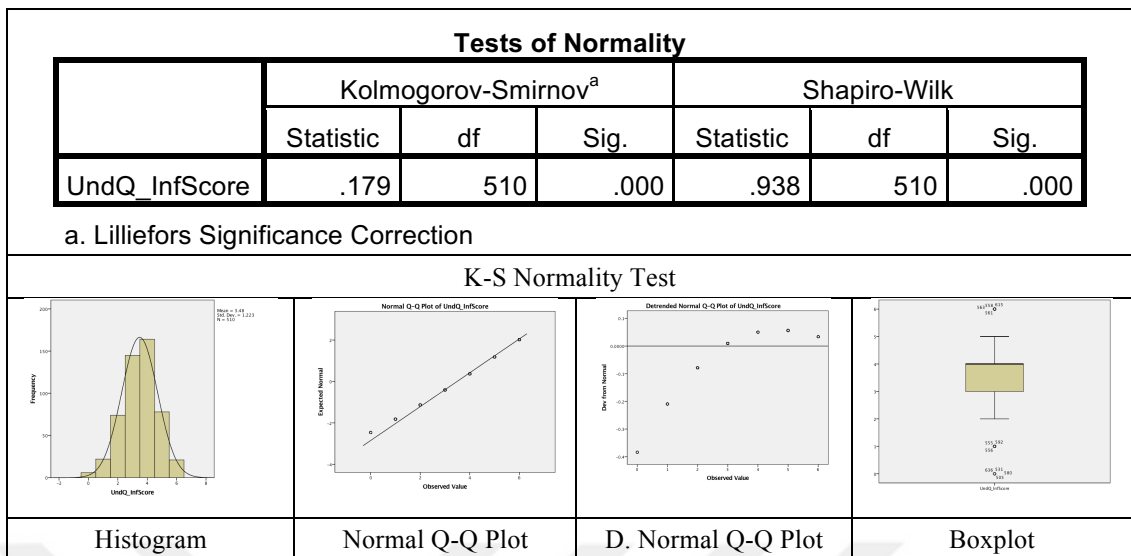

Figure 31 Normality test results for understandability task effectiveness (information)

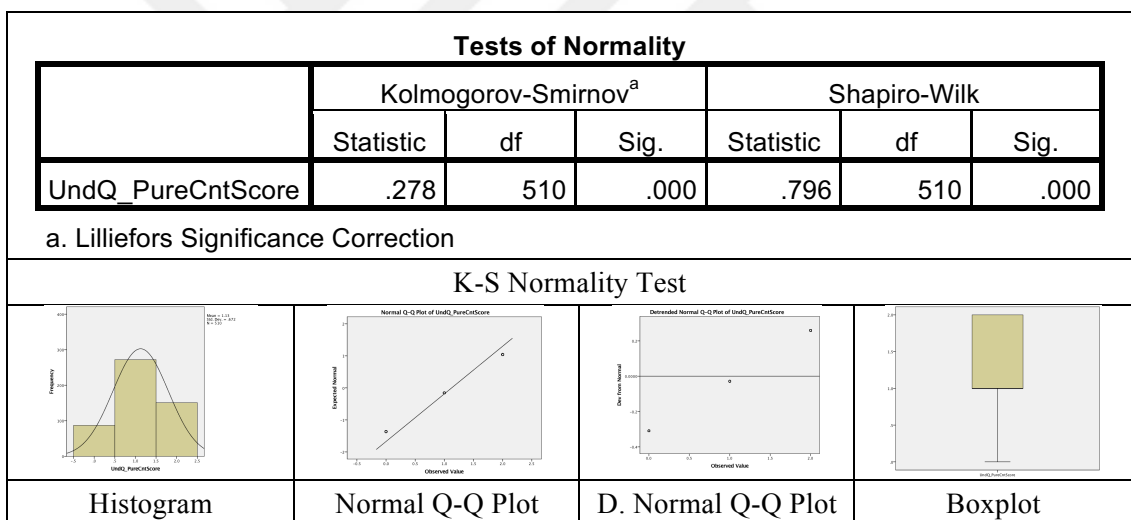

Figure 32 Normality test results for understandability task effectiveness (control flow-only)

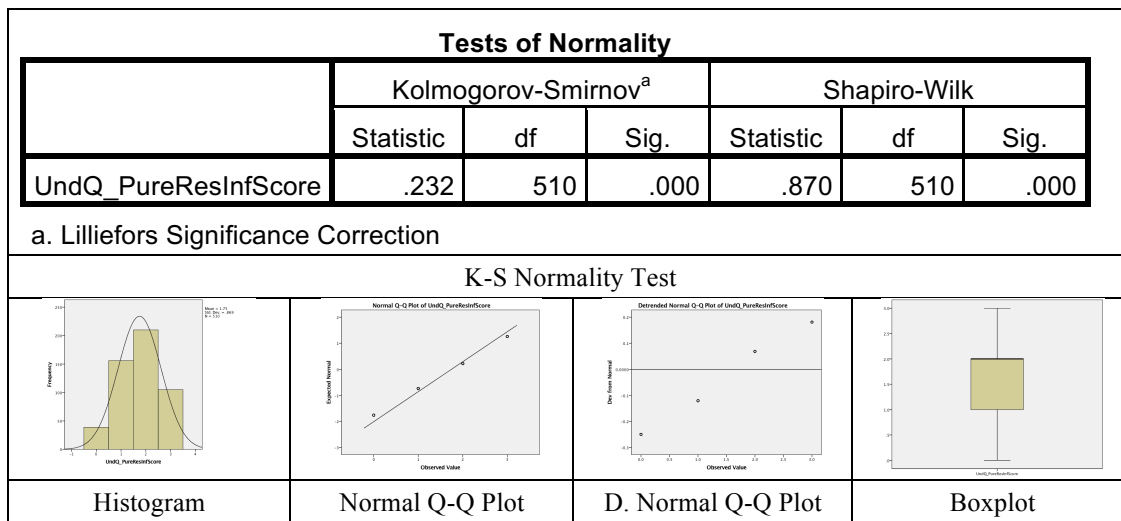

Figure 33 Normality test results for understandability task effectiveness (resource and information)

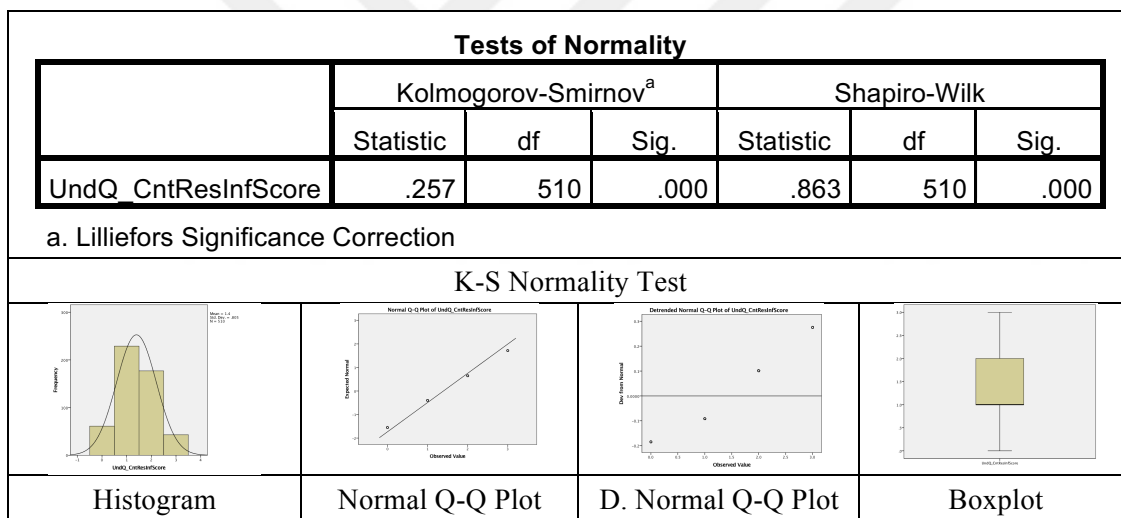

Figure 34 Normality test results for understandability task effectiveness (control flow, resource and information)

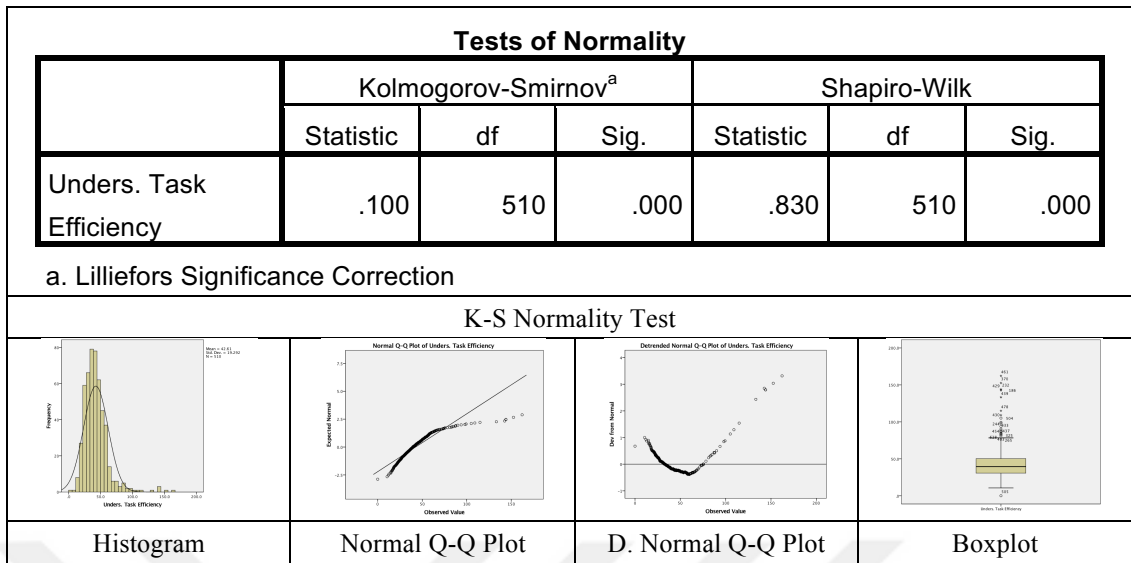

Figure 35 Normality test results for understandability task efficiency

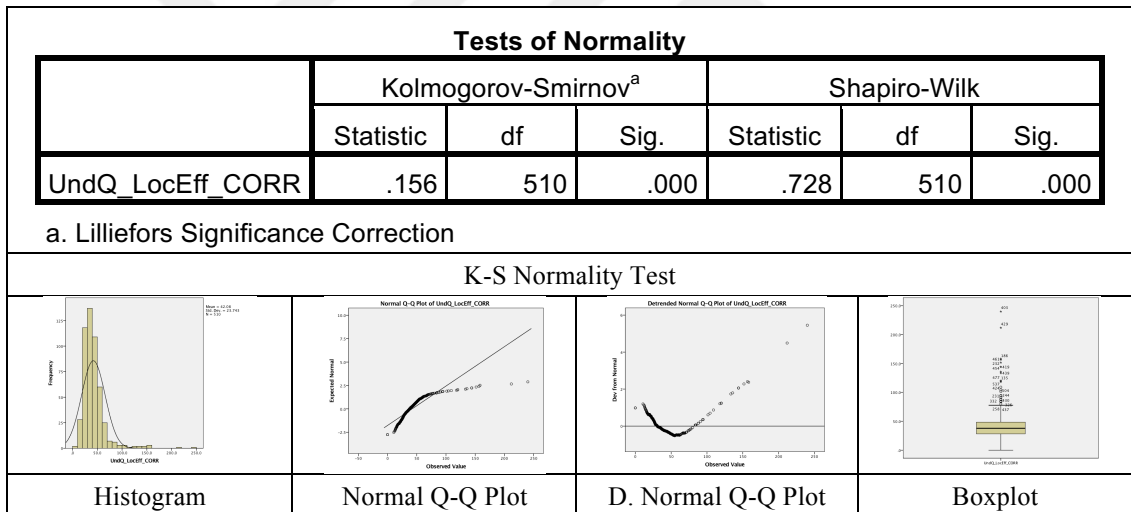

Figure 36 Normality test results for understandability task efficiency (local)

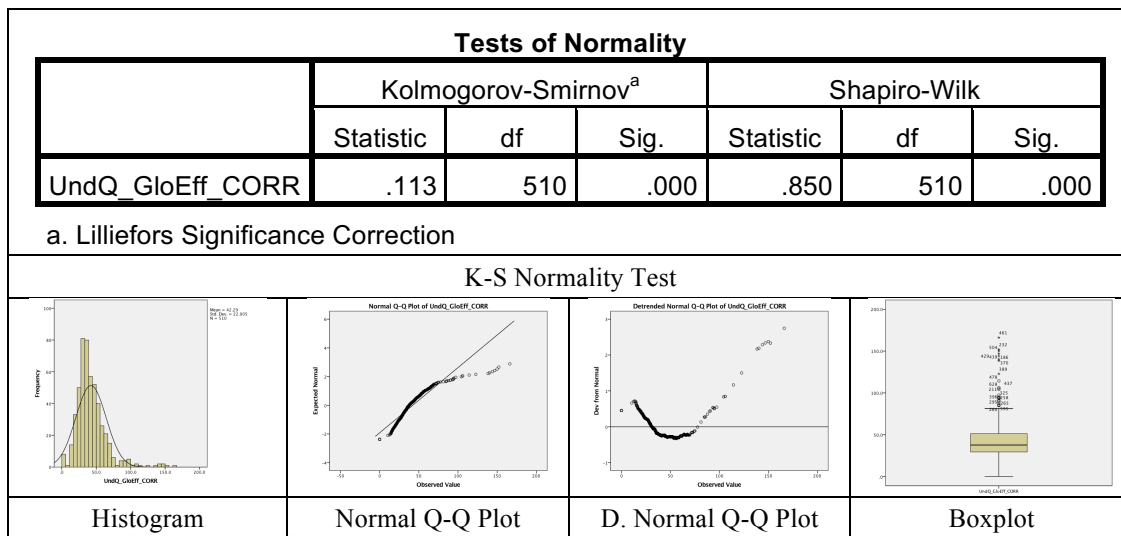

Figure 37 Normality test results for understandability task efficiency (global)

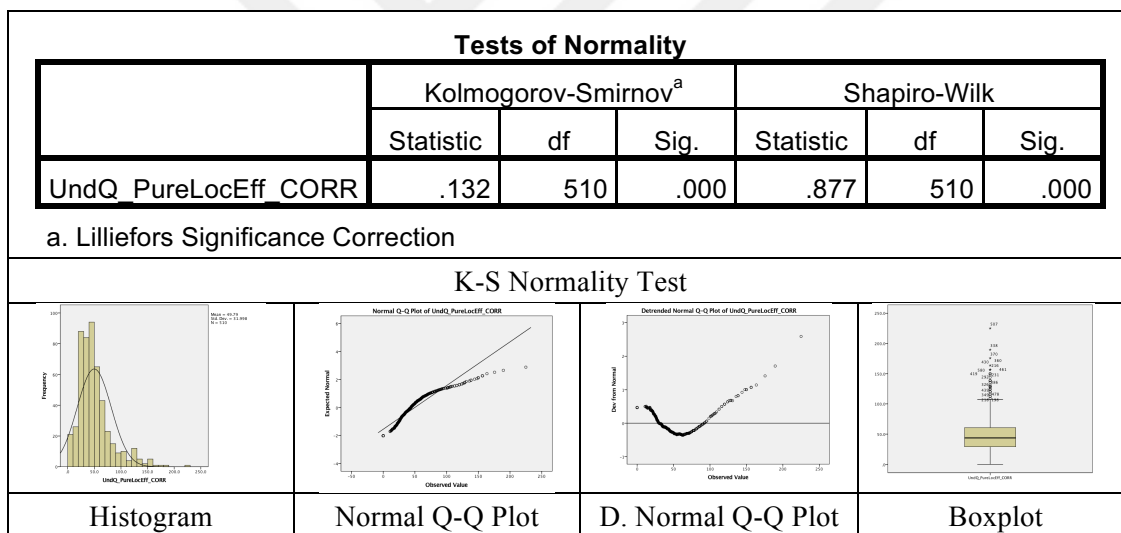

Figure 38 Normality test results for understandability task efficiency (local-only)

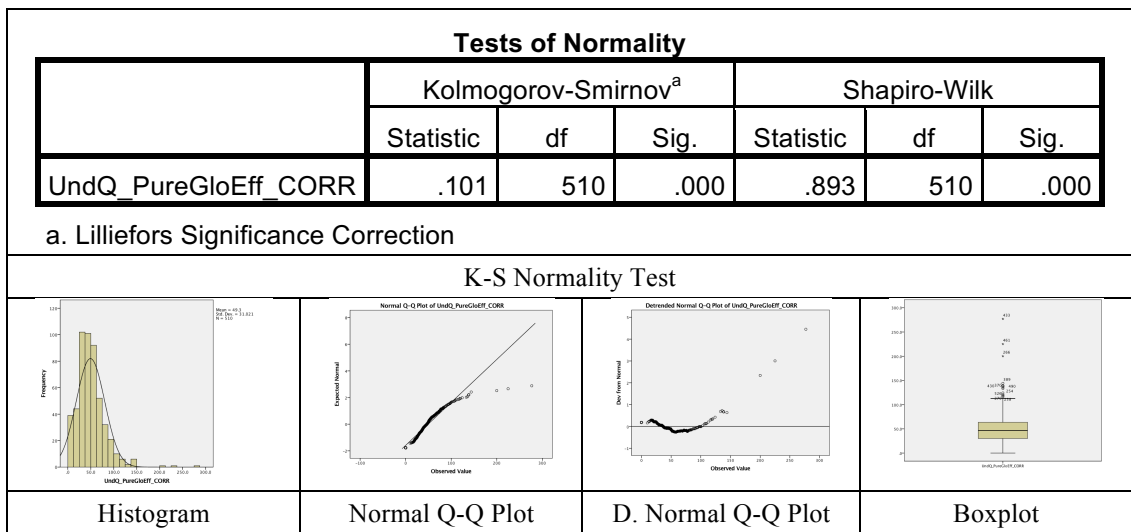

Figure 39 Normality test results for understandability task efficiency (global-only)

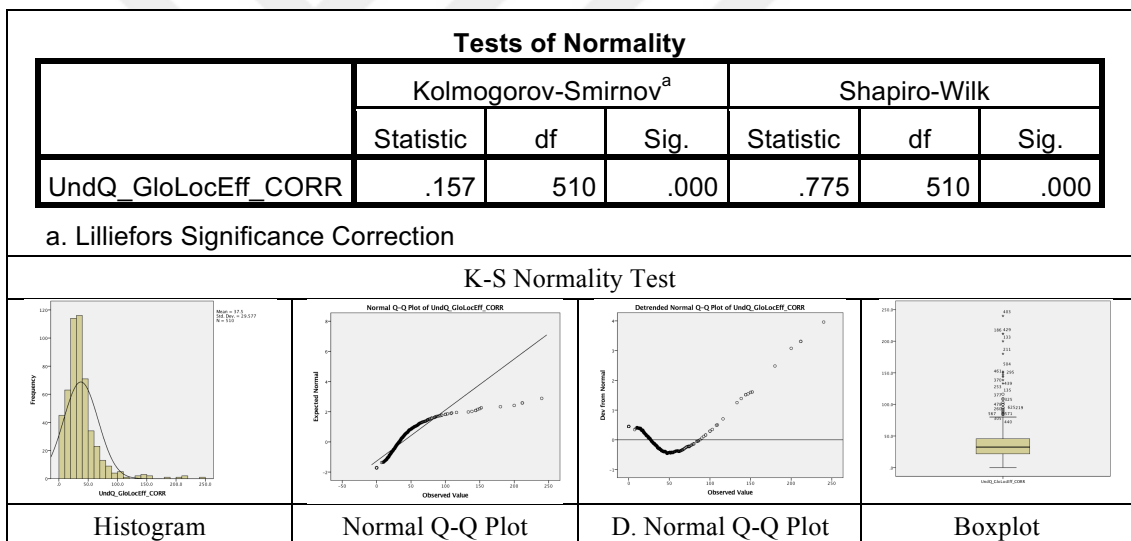

Figure 40 Normality test results for understandability task efficiency (global and local)

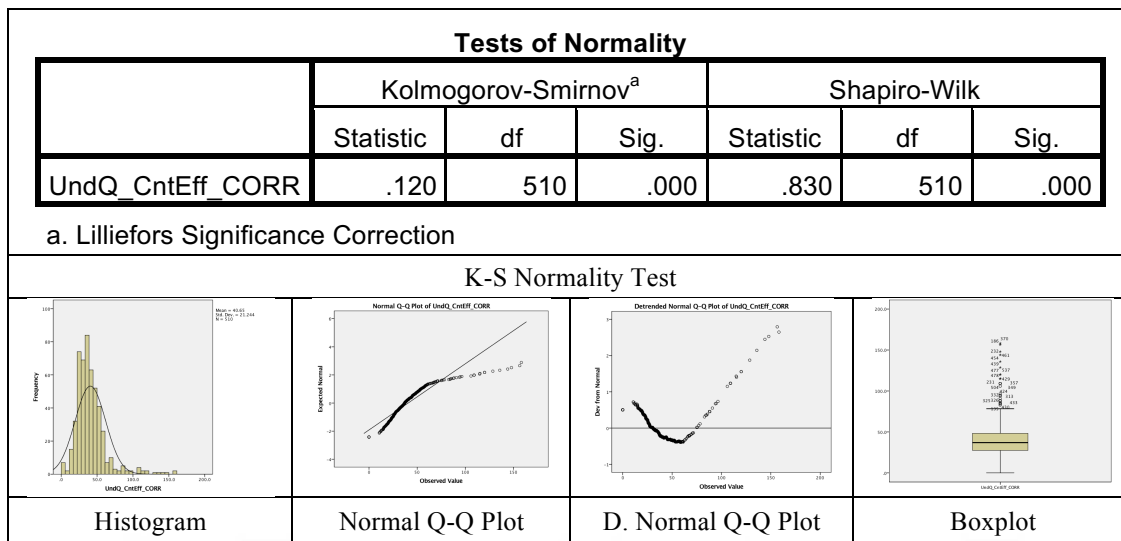

Figure 41 Normality test results for understandability task efficiency (control flow)

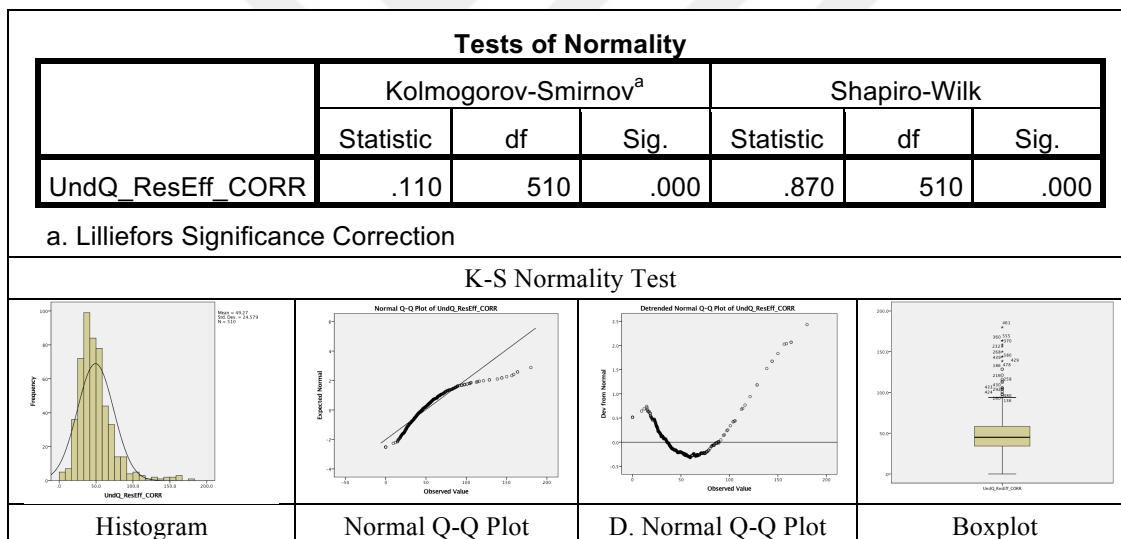

Figure 42 Normality test results for understandability task efficiency (resource)

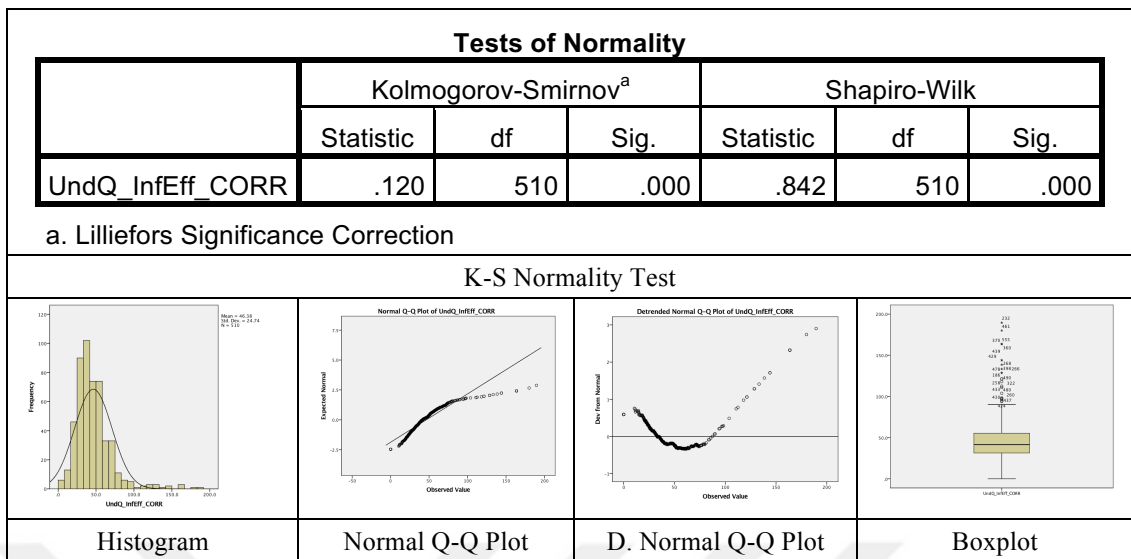

Figure 43 Normality test results for understandability task efficiency (information)

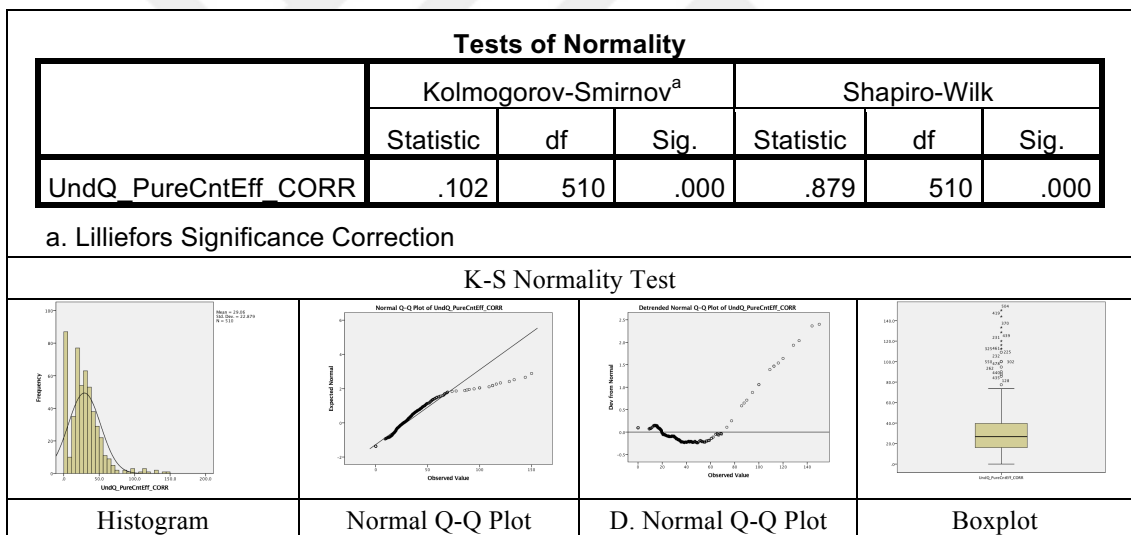

Figure 44 Normality test results for understandability task efficiency (control flow-only)

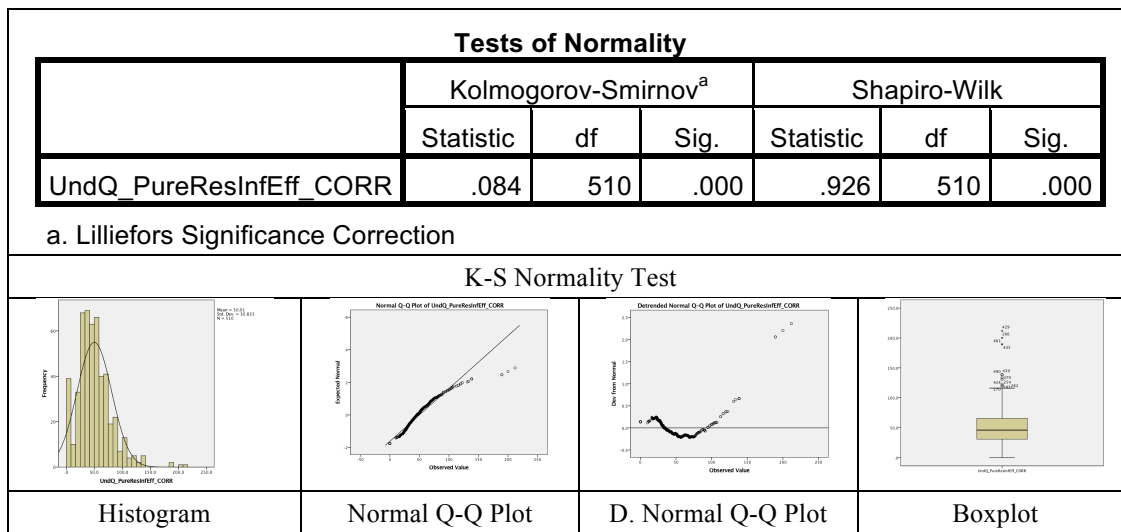

Figure 45 Normality test results for understandability task efficiency (resource and information only)

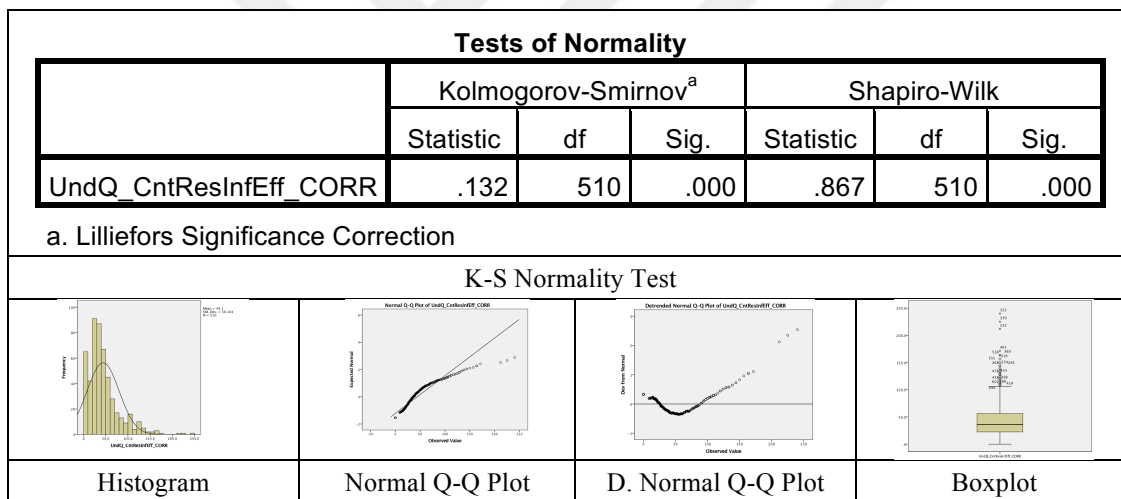

Figure 46 Normality test results for understandability task efficiency (control flow, resource and information)

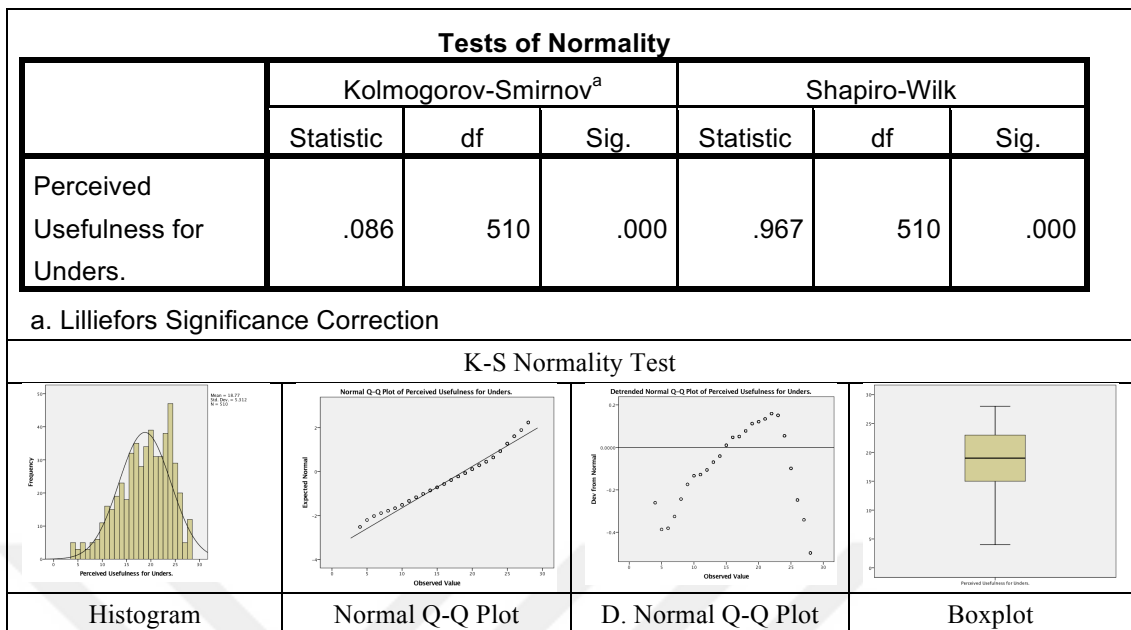

Figure 47 Normality test results for perceived usefulness for understandability

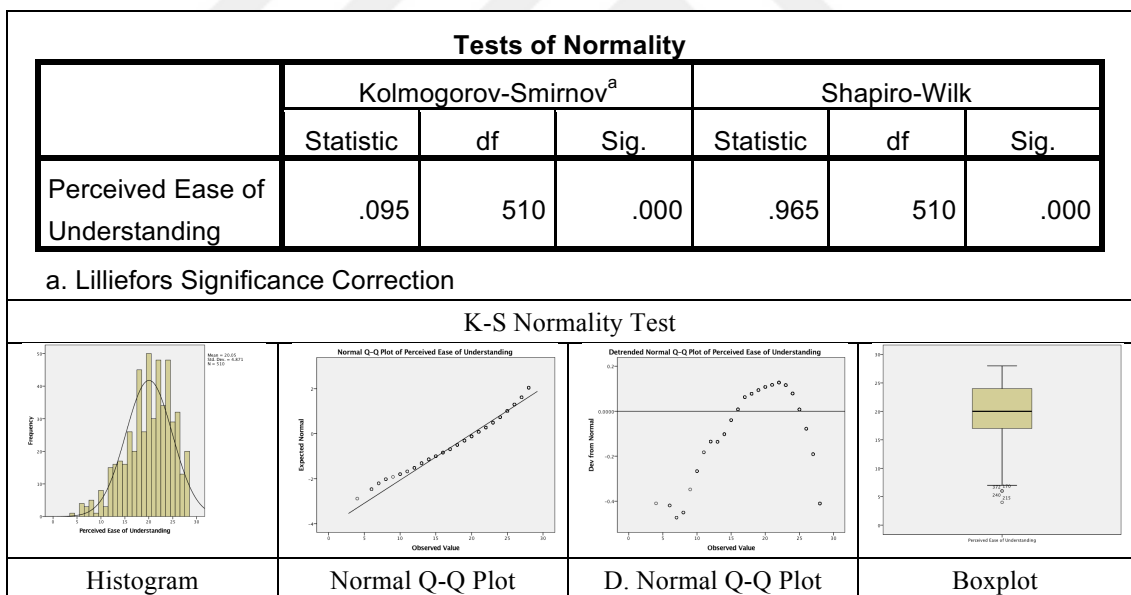

Figure 48 Normality test results for perceived ease of understanding

APPENDIX F: THE INFLUENCE OF MODULARITY REPRESENTATION

THE INFLUENCE OF MODULARITY REPRESENTATION

Table 36 Kruskal-Wallis test results for understandability variables by modularity representation

Hypothesis Test Summary

	Null Hypothesis	Test	Sig.	Decision
1	The distribution of Unders. Task Effectiveness is the same across categories of Modularity Representation.	Independent-Samples Kruskal-Wallis Test	.228	Retain the null hypothesis.
2	The distribution of Unders. Task Efficiency is the same across categories of Modularity Representation.	Independent-Samples Kruskal-Wallis Test	.974	Retain the null hypothesis.
3	The distribution of Perceived Usefulness for Unders. is the same across categories of Modularity Representation.	Independent-Samples Kruskal-Wallis Test	.181	Retain the null hypothesis.
4	The distribution of Perceived Ease of Understanding is the same across categories of Modularity Representation.	Independent-Samples Kruskal-Wallis Test	.006	Reject the null hypothesis.

Asymptotic significances are displayed. The significance level is .05.

Table 37 Kruskal-Wallis test results for further analysis of understandability task effectiveness by modularity representation

Hypothesis Test Summary

	Null Hypothesis	Test	Sig.	Decision
1	The distribution of UndQ_LocScore is the same across categories of Modularity Representation.	Independent-Samples Kruskal-Wallis Test	.046	Reject the null hypothesis.
2	The distribution of UndQ_GloScore is the same across categories of Modularity Representation.	Independent-Samples Kruskal-Wallis Test	.865	Retain the null hypothesis.
3	The distribution of UndQ_PureLocScore is the same across categories of Modularity Representation.	Independent-Samples Kruskal-Wallis Test	.003	Reject the null hypothesis.
4	The distribution of UndQ_PureGloScore is the same across categories of Modularity Representation.	Independent-Samples Kruskal-Wallis Test	.238	Retain the null hypothesis.
5	The distribution of UndQ_GloLocScore is the same across categories of Modularity Representation.	Independent-Samples Kruskal-Wallis Test	.824	Retain the null hypothesis.
6	The distribution of UndQ_CntScore is the same across categories of Modularity Representation.	Independent-Samples Kruskal-Wallis Test	.081	Retain the null hypothesis.
7	The distribution of UndQ_ResScore is the same across categories of Modularity Representation.	Independent-Samples Kruskal-Wallis Test	.731	Retain the null hypothesis.
8	The distribution of UndQ_InfScore is the same across categories of Modularity Representation.	Independent-Samples Kruskal-Wallis Test	.538	Retain the null hypothesis.
9	The distribution of UndQ_PureCntScore is the same across categories of Modularity Representation.	Independent-Samples Kruskal-Wallis Test	.015	Reject the null hypothesis.
10	The distribution of UndQ_PureResInfScore is the same across categories of Modularity Representation.	Independent-Samples Kruskal-Wallis Test	.246	Retain the null hypothesis.
11	The distribution of UndQ_CntResInfScore is the same across categories of Modularity Representation.	Independent-Samples Kruskal-Wallis Test	.579	Retain the null hypothesis.

Asymptotic significances are displayed. The significance level is .05.

Independent-Samples Kruskal-Wallis Test

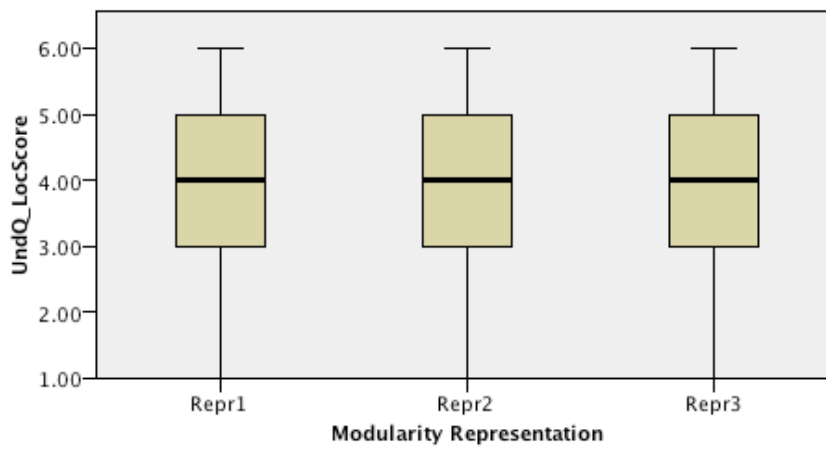

Total N	510
Test Statistic	6.146
Degrees of Freedom	2
Asymptotic Sig. (2-sided test)	.046

1. The test statistic is adjusted for ties.

Figure 49 Independent samples test view of modularity representation - understandability task effectiveness (local)

Pairwise Comparisons of Modularity Representation

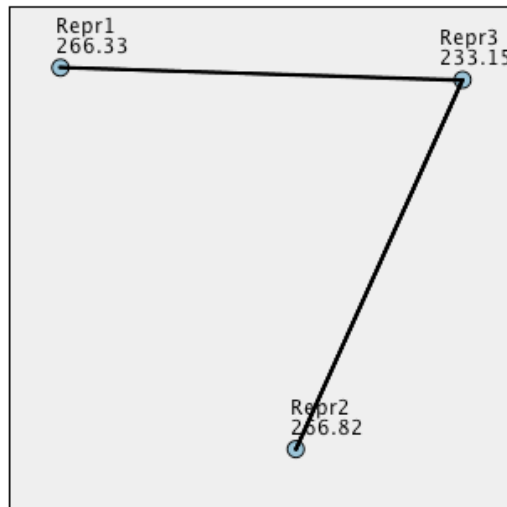

Each node shows the sample average rank of Modularity Representation.

Sample1-Sample2	Test Statistic	Std. Error	Std. Test Statistic	Sig.	Adj.Sig.
Repr3-Repr1	33.184	15.572	2.131	.033	.099
Repr3-Repr2	33.674	15.549	2.166	.030	.091
Repr1-Repr2	-.489	15.526	-.032	.975	1.000

Each row tests the null hypothesis that the Sample 1 and Sample 2 distributions are the same. Asymptotic significances (2-sided tests) are displayed. The significance level is .05.

Figure 50 Pairwise comparisons of understandability task effectiveness (local) by modularity representation

Table 38 Homogeneous subsets of understandability task effectiveness (local) by modularity representation

Homogeneous Subsets based on UndQ_LocScore			
		Subset	
		1	2
Sample ¹	Repr3	233.148	
	Repr1		266.332
	Repr2		266.822
Test Statistic		. ²	.000
Sig. (2-sided test)		.	.997
Adjusted Sig. (2-sided test)		.	.997
Homogeneous subsets are based on asymptotic significances. The significance level is .05.			
¹ Each cell shows the sample average rank of UndQ_LocScore.			
² Unable to compute because the subset contains only one sample.			

Independent-Samples Kruskal-Wallis Test

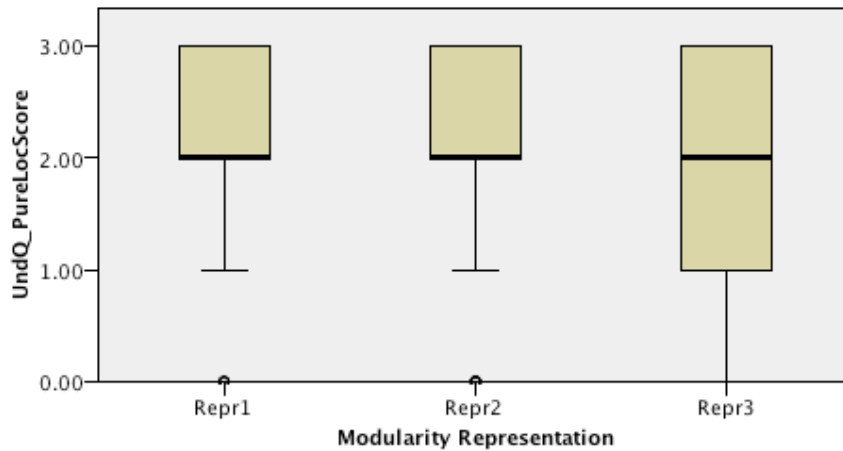

Total N	510
Test Statistic	11.572
Degrees of Freedom	2
Asymptotic Sig. (2-sided test)	.003

1. The test statistic is adjusted for ties.

Figure 51 Independent samples test view of modularity representation - understandability task effectiveness (local-only)

Pairwise Comparisons of Modularity Representation

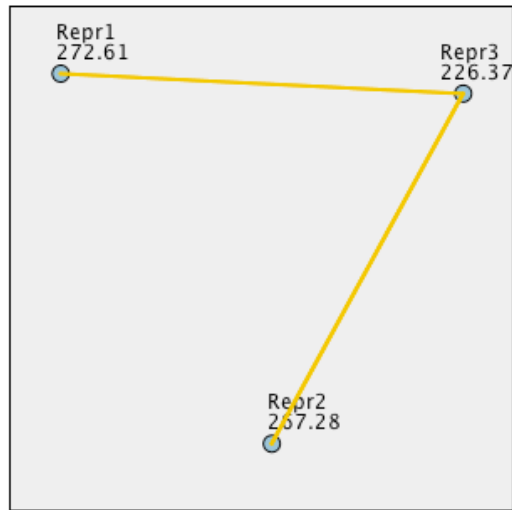

Each node shows the sample average rank of Modularity Representation.

Sample1-Sample2	Test Statistic	Std. Error	Std. Test Statistic	Sig.	Adj.Sig.
Repr3-Repr2	40.911	14.851	2.755	.006	.018
Repr3-Repr1	46.248	14.873	3.109	.002	.006
Repr2-Repr1	5.337	14.829	.360	.719	1.000

Each row tests the null hypothesis that the Sample 1 and Sample 2 distributions are the same. Asymptotic significances (2-sided tests) are displayed. The significance level is .05.

Figure 52 Pairwise comparisons of understandability task effectiveness (local-only) by modularity representation

Independent-Samples Kruskal-Wallis Test

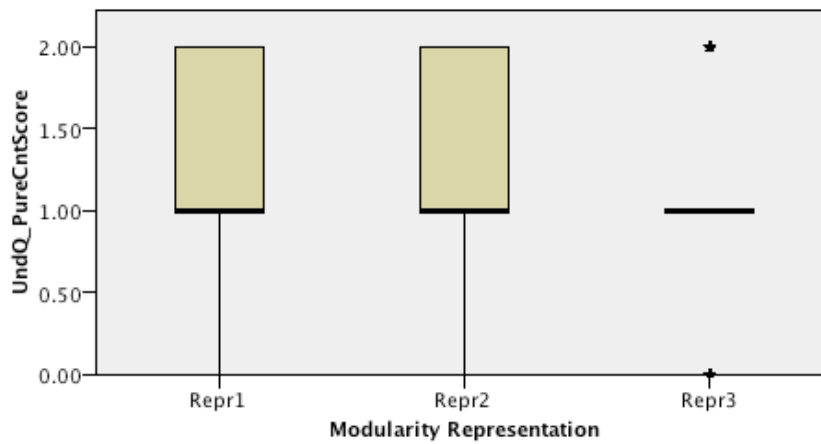

Total N	510
Test Statistic	8.429
Degrees of Freedom	2
Asymptotic Sig. (2-sided test)	.015

1. The test statistic is adjusted for ties.

Figure 53 Independent samples test view of modularity representation - understandability task effectiveness (control flow-only)

Pairwise Comparisons of Modularity Representation

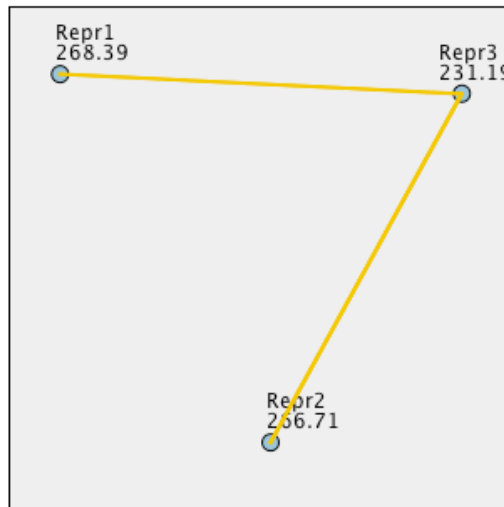

Each node shows the sample average rank of Modularity Representation.

Sample1-Sample2	Test Statistic	Std. Error	Std. Test Statistic	Sig.	Adj.Sig.
Repr3-Repr2	35.518	14.452	2.458	.014	.042
Repr3-Repr1	37.205	14.473	2.571	.010	.030
Repr2-Repr1	1.687	14.430	.117	.907	1.000

Each row tests the null hypothesis that the Sample 1 and Sample 2 distributions are the same. Asymptotic significances (2-sided tests) are displayed. The significance level is .05.

Figure 54 Pairwise comparisons of modularity representation - understandability task effectiveness (control flow-only)

Table 39 Kruskal-Wallis test results for further analysis of understandability task efficiency by modularity representation

Hypothesis Test Summary

	Null Hypothesis	Test	Sig.	Decision
1	The distribution of UndQ_LocEff_CORR is the same across categories of Modularity Representation.	Independent-Samples Kruskal-Wallis Test	.996	Retain the null hypothesis.
2	The distribution of UndQ_GloEff_CORR is the same across categories of Modularity Representation.	Independent-Samples Kruskal-Wallis Test	.953	Retain the null hypothesis.
3	The distribution of UndQ_PureLocEff_CORR is the same across categories of Modularity Representation.	Independent-Samples Kruskal-Wallis Test	.707	Retain the null hypothesis.
4	The distribution of UndQ_PureGloEff_CORR is the same across categories of Modularity Representation.	Independent-Samples Kruskal-Wallis Test	.747	Retain the null hypothesis.
5	The distribution of UndQ_GloLocEff_CORR is the same across categories of Modularity Representation.	Independent-Samples Kruskal-Wallis Test	.430	Retain the null hypothesis.
6	The distribution of UndQ_CntEff_CORR is the same across categories of Modularity Representation.	Independent-Samples Kruskal-Wallis Test	.934	Retain the null hypothesis.
7	The distribution of UndQ_ResEff_CORR is the same across categories of Modularity Representation.	Independent-Samples Kruskal-Wallis Test	.522	Retain the null hypothesis.
8	The distribution of UndQ_InfEff_CORR is the same across categories of Modularity Representation.	Independent-Samples Kruskal-Wallis Test	.735	Retain the null hypothesis.
9	The distribution of UndQ_PureCntEff_CORR is the same across categories of Modularity Representation.	Independent-Samples Kruskal-Wallis Test	.199	Retain the null hypothesis.
10	The distribution of UndQ_PureResInfEff_CORR is the same across categories of Modularity Representation.	Independent-Samples Kruskal-Wallis Test	.927	Retain the null hypothesis.
11	The distribution of UndQ_CntResInfEff_CORR is the same across categories of Modularity Representation.	Independent-Samples Kruskal-Wallis Test	.180	Retain the null hypothesis.

Asymptotic significances are displayed. The significance level is .05.

Independent-Samples Kruskal-Wallis Test

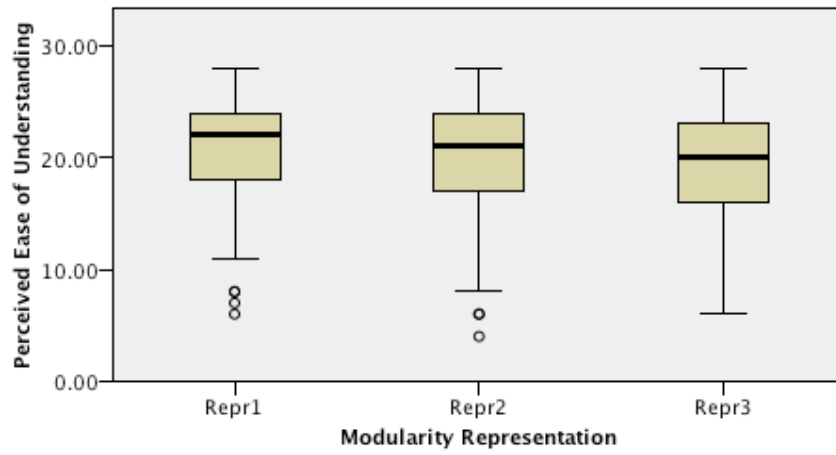

Total N	510
Test Statistic	10.118
Degrees of Freedom	2
Asymptotic Sig. (2-sided test)	.006

1. The test statistic is adjusted for ties.

Figure 55 Independent samples test view of modularity representation - perceived ease of understanding

Pairwise Comparisons of Modularity Representation

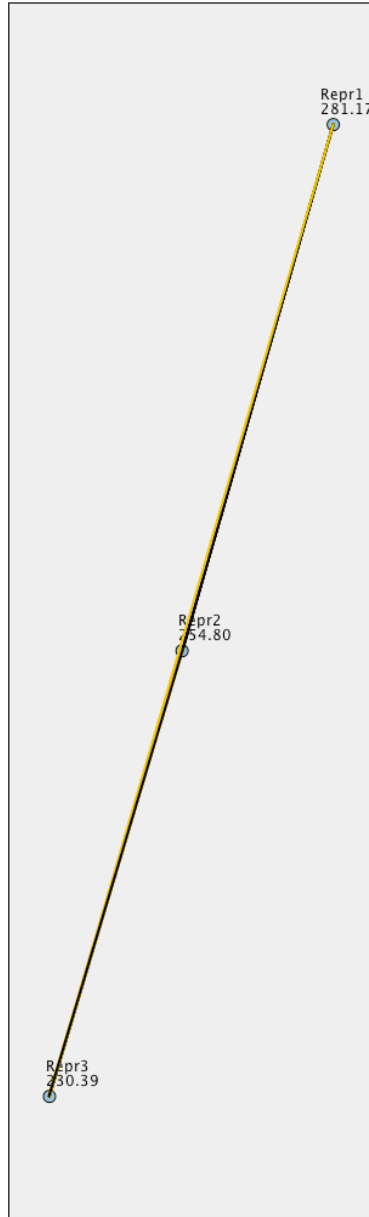

Each node shows the sample average rank of Modularity Representation.

Sample1-Sample2	Test Statistic	Std. Error	Std. Test Statistic	Sig.	Adj.Sig.
Repr3-Repr2	24.411	15.947	1.531	.126	.377
Repr3-Repr1	50.783	15.970	3.180	.001	.004
Repr2-Repr1	26.372	15.923	1.656	.098	.293

Each row tests the null hypothesis that the Sample 1 and Sample 2 distributions are the same. Asymptotic significances (2-sided tests) are displayed. The significance level is .05.

Figure 56 Pairwise comparisons of modularity representation - perceived ease of understanding

APPENDIX G: THE INFLUENCE OF PRESENTATION MEDIUM

THE INFLUENCE OF PRESENTATION MEDIUM

Table 40 Kruskal-Wallis test results for understandability variables by presentation medium

Hypothesis Test Summary				
	Null Hypothesis	Test	Sig.	Decision
1	The distribution of Unders. Task Effectiveness is the same across categories of Presentation Medium.	Independent-Samples Kruskal-Wallis Test	.019	Reject the null hypothesis.
2	The distribution of Unders. Task Efficiency is the same across categories of Presentation Medium.	Independent-Samples Kruskal-Wallis Test	.658	Retain the null hypothesis.
3	The distribution of Perceived Usefulness for Unders. is the same across categories of Presentation Medium.	Independent-Samples Kruskal-Wallis Test	.000	Reject the null hypothesis.
4	The distribution of Perceived Ease of Understanding is the same across categories of Presentation Medium.	Independent-Samples Kruskal-Wallis Test	.002	Reject the null hypothesis.

Asymptotic significances are displayed. The significance level is .05.

Independent-Samples Kruskal-Wallis Test

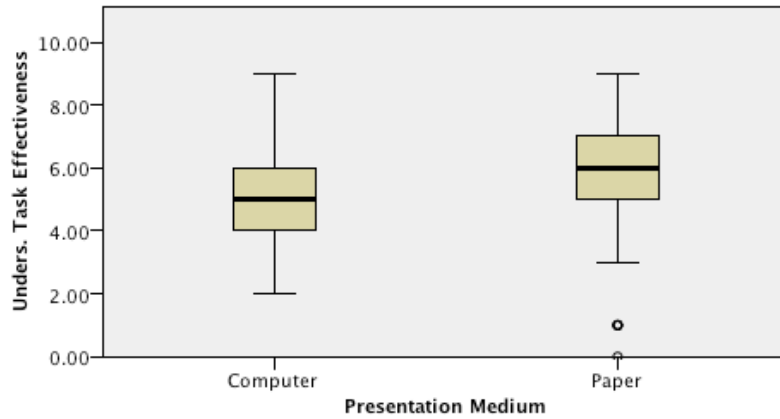

Total N	510
Test Statistic	5.522
Degrees of Freedom	1
Asymptotic Sig. (2-sided test)	.019

1. The test statistic is adjusted for ties.
2. Multiple comparisons are not performed because there are less than three test fields.

Figure 57 Independent samples test view of presentation medium - understandability task effectiveness

Independent-Samples Kruskal-Wallis Test

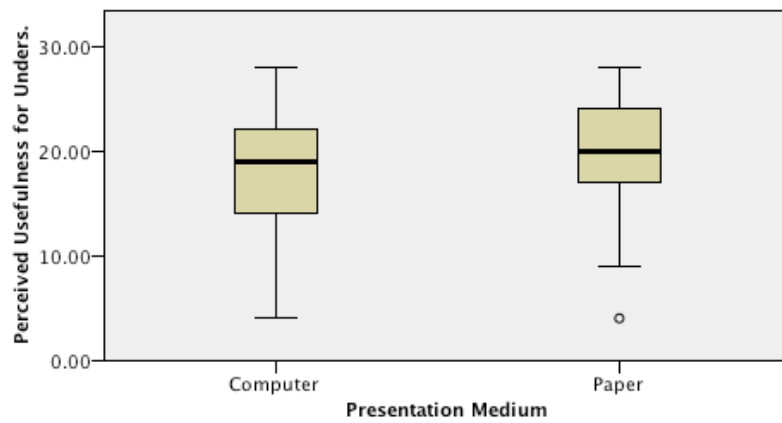

Total N	510
Test Statistic	17.612
Degrees of Freedom	1
Asymptotic Sig. (2-sided test)	.000

1. The test statistic is adjusted for ties.
2. Multiple comparisons are not performed because there are less than three test fields.

Figure 58 Independent samples test view of presentation medium - perceived usefulness for understandability

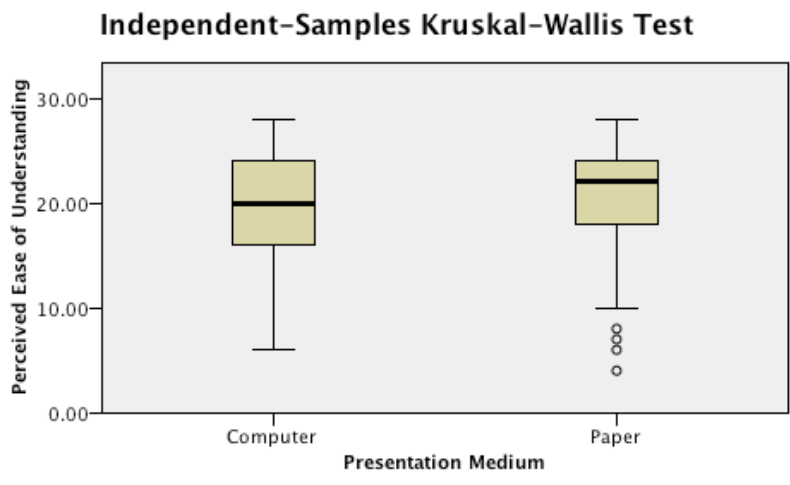

Total N	510
Test Statistic	9.316
Degrees of Freedom	1
Asymptotic Sig. (2-sided test)	.002

1. The test statistic is adjusted for ties.
2. Multiple comparisons are not performed because there are less than three test fields.

Figure 59 Independent samples test view of presentation medium - perceived ease of understanding

APPENDIX H: THE INFLUENCE OF EXPERIENCE WITH PROCESS MODELS

THE INFLUENCE OF EXPERIENCE WITH PROCESS MODELS

Table 41 Kruskal-Wallis test results for understandability variables by experience with process models

Hypothesis Test Summary

	Null Hypothesis	Test	Sig.	Decision
1	The distribution of Unders. Task Effectiveness is the same across categories of PM_Experience.	Independent-Samples Kruskal-Wallis Test	.125	Retain the null hypothesis.
2	The distribution of Unders. Task Efficiency is the same across categories of PM_Experience.	Independent-Samples Kruskal-Wallis Test	.111	Retain the null hypothesis.
3	The distribution of Perceived Usefulness for Unders. is the same across categories of PM_Experience.	Independent-Samples Kruskal-Wallis Test	.919	Retain the null hypothesis.
4	The distribution of Perceived Ease of Understanding is the same across categories of PM_Experience.	Independent-Samples Kruskal-Wallis Test	.795	Retain the null hypothesis.

Asymptotic significances are displayed. The significance level is .05.

APPENDIX I: THE INFLUENCE OF INTENSITY OF WORKING WITH PROCESS MODELS

THE INFLUENCE OF INTENSITY OF WORKING WITH PROCESS MODELS

Table 42 Kruskal-Wallis test results for understandability variables by intensity of working with process models

Hypothesis Test Summary

	Null Hypothesis	Test	Sig.	Decision
1	The distribution of Unders. Task Effectiveness is the same across categories of PM_Intensity.	Independent-Samples Kruskal-Wallis Test	.846	Retain the null hypothesis.
2	The distribution of Unders. Task Efficiency is the same across categories of PM_Intensity.	Independent-Samples Kruskal-Wallis Test	.011	Reject the null hypothesis.
3	The distribution of Perceived Usefulness for Unders. is the same across categories of PM_Intensity.	Independent-Samples Kruskal-Wallis Test	.300	Retain the null hypothesis.
4	The distribution of Perceived Ease of Understanding is the same across categories of PM_Intensity.	Independent-Samples Kruskal-Wallis Test	.016	Reject the null hypothesis.

Asymptotic significances are displayed. The significance level is .05.

Independent-Samples Kruskal-Wallis Test

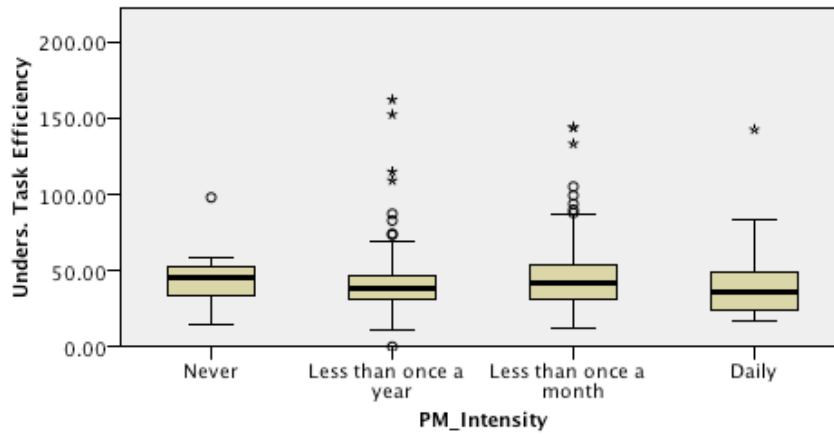

Total N	510
Test Statistic	11.079
Degrees of Freedom	3
Asymptotic Sig. (2-sided test)	.011

1. The test statistic is adjusted for ties.

Figure 60 Independent samples test view of intensity of working with process models - understandability task efficiency

Pairwise Comparisons of PM_Intensity

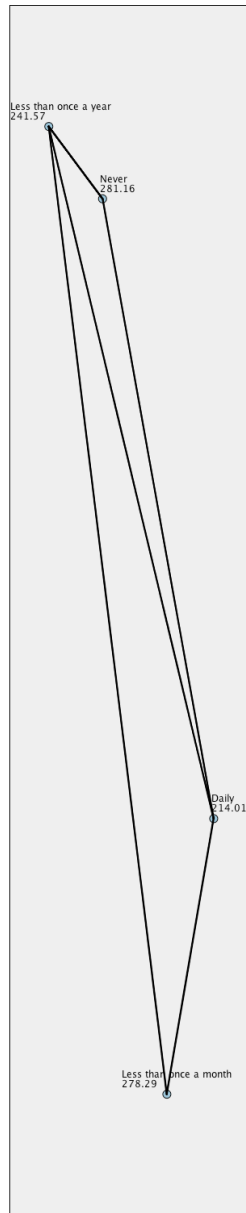

Each node shows the sample average rank of PM_Intensity.

Sample1-Sample2	Test Statistic	Std. Error	Std. Test Statistic	Sig.	Adj.Sig.
Daily-Less than once a year	27.561	24.604	1.120	.263	1.000
Daily-Less than once a month	64.279	25.201	2.551	.011	.065
Daily-Never	67.146	32.994	2.035	.042	.251
Less than once a year-Less than once a month	-36.718	14.363	-2.556	.011	.063
Less than once a year-Never	39.585	25.686	1.541	.123	.740
Less than once a month-Never	2.867	26.259	.109	.913	1.000

Each row tests the null hypothesis that the Sample 1 and Sample 2 distributions are the same. Asymptotic significances (2-sided tests) are displayed. The significance level is .05.

Figure 61 Pairwise comparisons of intensity of working with process models - understandability task efficiency

Table 43 Homogeneous subsets of understandability task efficiency by intensity of working with process models

Homogeneous Subsets based on Unders. Task Efficiency			
		Subset	
		1	2
Sample¹	Daily	214.012	
	Less than once a year	241.573	
	Less than once a month		278.291
	Never		281.158
Test Statistic		1.6616 ²	.004
Sig. (2-sided test)		.197	.948
Adjusted Sig. (2-sided test)		.356	.997
Homogeneous subsets are based on asymptotic significances. The significance level is .05.			
¹ Each cell shows the sample average rank of Unders. Task Efficiency.			
² Unable to compute because the subset contains only one sample.			

Independent-Samples Kruskal-Wallis Test

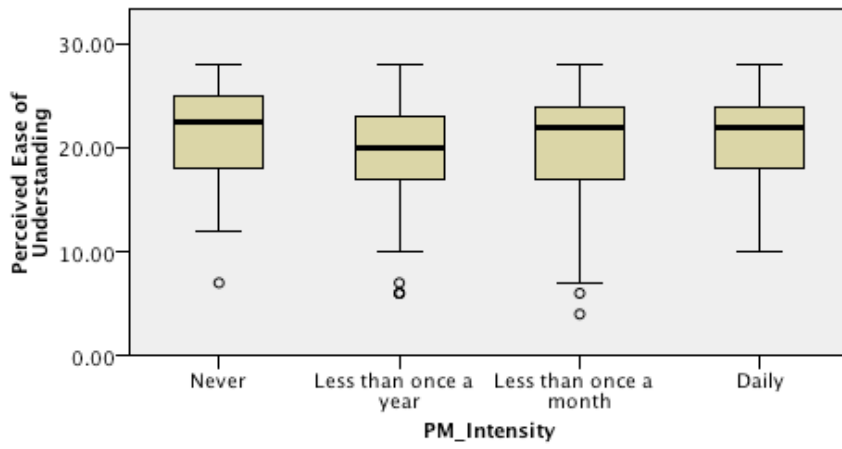

Total N	510
Test Statistic	10.295
Degrees of Freedom	3
Asymptotic Sig. (2-sided test)	.016

1. The test statistic is adjusted for ties.

Figure 62 Independent samples test view of intensity of working with process models - perceived ease of understanding

Pairwise Comparisons of PM_Intensity

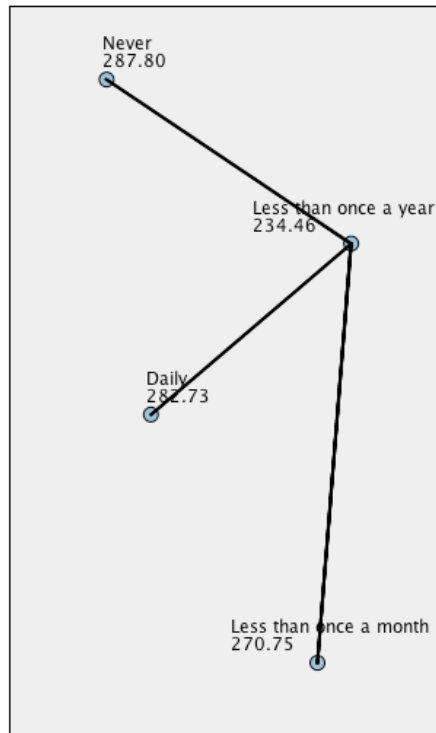

Each node shows the sample average rank of PM_Intensity.

Sample 1-Sample 2	Test Statistic	Std. Error	Std. Test Statistic	Sig.	Adj.Sig.
Less than once a year-Less than once a month	-36.295	14.329	-2.533	.011	.068
Less than once a year-Daily	-48.271	24.546	-1.967	.049	.295
Less than once a year-Never	53.347	25.625	2.082	.037	.224
Less than once a month-Daily	-11.976	25.141	-.476	.634	1.000
Less than once a month-Never	17.053	26.197	.651	.515	1.000
Daily-Never	5.076	32.915	.154	.877	1.000

Each row tests the null hypothesis that the Sample 1 and Sample 2 distributions are the same. Asymptotic significances (2-sided tests) are displayed. The significance level is .05.

Figure 63 Pairwise comparisons of intensity of working with process models - perceived ease of understanding

Table 44 Homogeneous subsets of perceived ease of understanding by intensity of working with process models

Homogeneous Subsets based on Perceived Ease of Understanding			
		Subset	
		1	2
Sample¹	Less than once a year	234.455	
	Less than once a month		270.750
	Daily		282.726
	Never		287.803
Test Statistic		.	.572
Sig. (2-sided test)		.	.751
Adjusted Sig. (2-sided test)		.	.751
Homogeneous subsets are based on asymptotic significances. The significance level is .05.			
¹ Each cell shows the sample average rank of Perceived Ease of Understanding .			
² Unable to compute because the subset contains only one sample.			

APPENDIX J: THE INFLUENCE OF FAMILIARITY WITH PROCESS DOMAIN

THE INFLUENCE OF FAMILIARITY WITH PROCESS DOMAIN

Table 45 Kruskal-Wallis test results for understandability variables by familiarity with domain

Hypothesis Test Summary

	Null Hypothesis	Test	Sig.	Decision
1	The distribution of Unders. Task Effectiveness is the same across categories of PD_Familiarity.	Independent-Samples Kruskal-Wallis Test	.570	Retain the null hypothesis.
2	The distribution of Unders. Task Efficiency is the same across categories of PD_Familiarity.	Independent-Samples Kruskal-Wallis Test	.242	Retain the null hypothesis.
3	The distribution of Perceived Usefulness for Unders. is the same across categories of PD_Familiarity.	Independent-Samples Kruskal-Wallis Test	.410	Retain the null hypothesis.
4	The distribution of Perceived Ease of Understanding is the same across categories of PD_Familiarity.	Independent-Samples Kruskal-Wallis Test	.407	Retain the null hypothesis.

Asymptotic significances are displayed. The significance level is .05.

APPENDIX K: THE INFLUENCE OF BP MODELING KNOWLEDGE

THE INFLUENCE OF BP MODELING KNOWLEDGE

Table 46 Kruskal-Wallis test results for understandability variables by BP modeling knowledge

Hypothesis Test Summary

	Null Hypothesis	Test	Sig.	Decision
1	The distribution of Unders. Task Effectiveness is the same across categories of Know_LevelBPM.	Independent-Samples Kruskal-Wallis Test	.412	Retain the null hypothesis.
2	The distribution of Unders. Task Efficiency is the same across categories of Know_LevelBPM.	Independent-Samples Kruskal-Wallis Test	.016	Reject the null hypothesis.
3	The distribution of Perceived Usefulness for Unders. is the same across categories of Know_LevelBPM.	Independent-Samples Kruskal-Wallis Test	.748	Retain the null hypothesis.
4	The distribution of Perceived Ease of Understanding is the same across categories of Know_LevelBPM.	Independent-Samples Kruskal-Wallis Test	.207	Retain the null hypothesis.

Asymptotic significances are displayed. The significance level is .05.

Independent-Samples Kruskal-Wallis Test

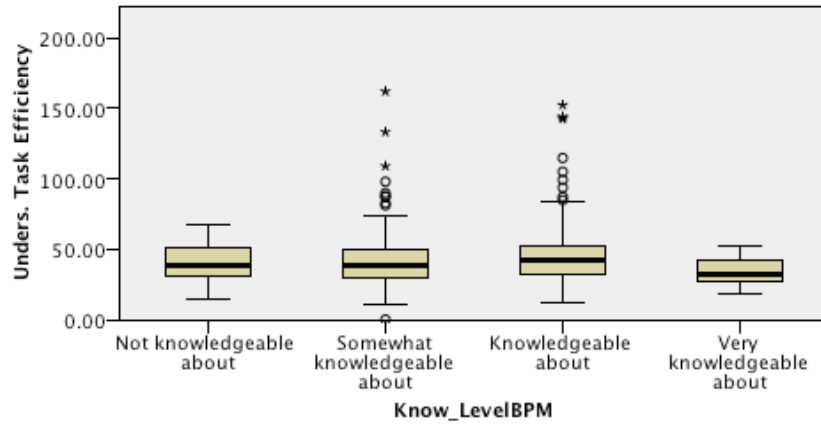

Total N	510
Test Statistic	10.286
Degrees of Freedom	3
Asymptotic Sig. (2-sided test)	.016

1. The test statistic is adjusted for ties.

Figure 64 Independent samples test view of BP modeling knowledge – understandability task efficiency

Pairwise Comparisons of Know_LevelBPM

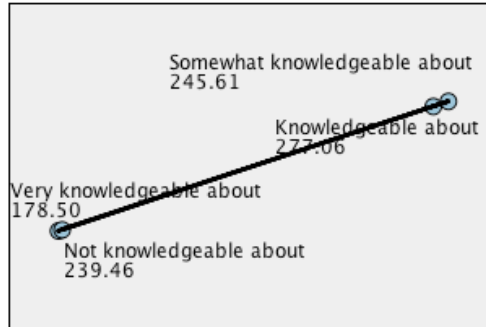

Each node shows the sample average rank of Know_LevelBPM.

Sample1-Sample2	Test Statistic	Std. Error	Std. Test Statistic	Sig.	Adj.Sig.
Very knowledgeable about- Not knowledgeable about	60.961	43.918	1.388	.165	.991
Very knowledgeable about- Somewhat knowledgeable about	67.106	37.985	1.767	.077	.464
Very knowledgeable about- Knowledgeable about	98.557	38.273	2.575	.010	.060
Not knowledgeable about- Somewhat knowledgeable about	-6.146	25.632	-.240	.811	1.000
Not knowledgeable about- Knowledgeable about	-37.596	26.058	-1.443	.149	.894
Somewhat knowledgeable about- Knowledgeable about	-31.451	13.893	-2.264	.024	.142

Each row tests the null hypothesis that the Sample 1 and Sample 2 distributions are the same. Asymptotic significances (2-sided tests) are displayed. The significance level is .05.

Figure 65 Pairwise comparisons of BP modeling knowledge - understandability task efficiency

Table 47 Homogeneous subsets of understandability task efficiency by BP modeling knowledge

Homogeneous Subsets based on Unders. Task Efficiency			
		Subset	
		1	2
Sample¹	Very knowledgeable about	178.500	
	Not knowledgeable about	239.461	239.461
	Somewhat knowledgeable about	245.606	245.606
	Knowledgeable about		277.057
Test Statistic		3.272	5.830
Sig. (2-sided test)		.195	.054
Adjusted Sig. (2-sided test)		.195	.054
Homogeneous subsets are based on asymptotic significances. The significance level is .05.			
¹ Each cell shows the sample average rank of Unders. Task Efficiency.			

APPENDIX L: THE INFLUENCE OF BPMN 2.0 KNOWLEDGE

THE INFLUENCE OF BPMN 2.0 KNOWLEDGE

Table 48 Kruskal-Wallis test results for understandability variables by BPMN 2.0 knowledge

Hypothesis Test Summary				
	Null Hypothesis	Test	Sig.	Decision
1	The distribution of Unders. Task Effectiveness is the same across categories of Know_LevelBPMN.	Independent-Samples Kruskal-Wallis Test	.255	Retain the null hypothesis.
2	The distribution of Unders. Task Efficiency is the same across categories of Know_LevelBPMN.	Independent-Samples Kruskal-Wallis Test	.000	Reject the null hypothesis.
3	The distribution of Perceived Usefulness for Unders. is the same across categories of Know_LevelBPMN.	Independent-Samples Kruskal-Wallis Test	.132	Retain the null hypothesis.
4	The distribution of Perceived Ease of Understanding is the same across categories of Know_LevelBPMN.	Independent-Samples Kruskal-Wallis Test	.010	Reject the null hypothesis.

Asymptotic significances are displayed. The significance level is .05.

Independent-Samples Kruskal-Wallis Test

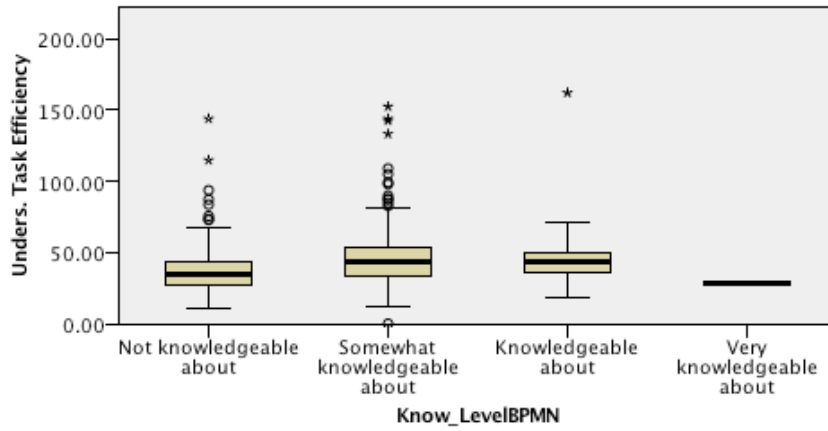

Total N	510
Test Statistic	39.461
Degrees of Freedom	3
Asymptotic Sig. (2-sided test)	.000

1. The test statistic is adjusted for ties.

Figure 66 Independent samples test view of BPMN 2.0 knowledge - understandability task efficiency

Pairwise ...

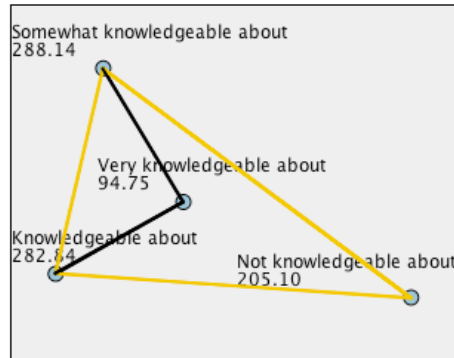

Each node shows the sample average rank of Know_LevelBPMN.

Sample1-Sample2	Test Statistic	Std. Error	Std. Test Statistic	Sig.	Adj.Sig.
Very knowledgeable about-Not knowledgeable about	110.354	104.746	1.054	.292	1.000
Very knowledgeable about-Knowledgeable about	188.092	105.927	1.776	.076	.455
Very knowledgeable about-Somewhat knowledgeable about	193.395	104.611	1.849	.065	.387
Not knowledgeable about-Knowledgeable about	-77.738	21.796	-3.567	.000	.002
Not knowledgeable about-Somewhat knowledgeable about	-83.040	14.069	-5.902	.000	.000
Knowledgeable about-Somewhat knowledgeable about	5.303	21.137	.251	.802	1.000

Each row tests the null hypothesis that the Sample 1 and Sample 2 distributions are the same. Asymptotic significances (2-sided tests) are displayed. The significance level is .05.

Figure 67 Pairwise comparisons of BPMN 2.0 knowledge - understandability task efficiency

Independent-Samples Kruskal-Wallis Test

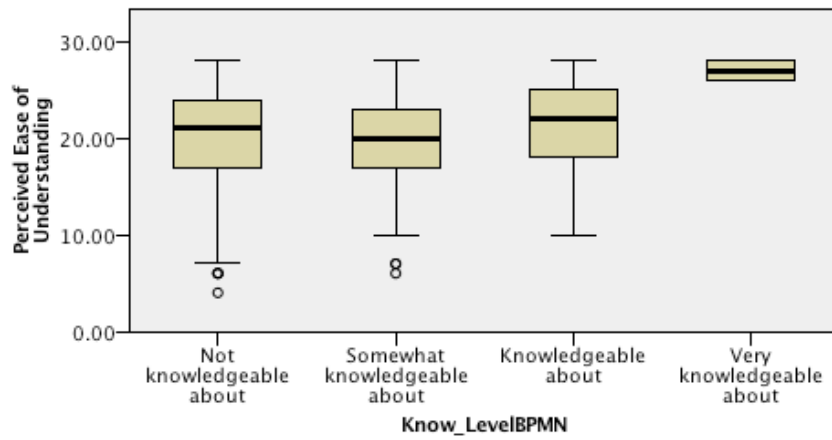

Total N	510
Test Statistic	11.454
Degrees of Freedom	3
Asymptotic Sig. (2-sided test)	.010

1. The test statistic is adjusted for ties.

Figure 68 Independent samples test view of BPMN 2.0 knowledge - perceived ease of understanding

Pairwise ...

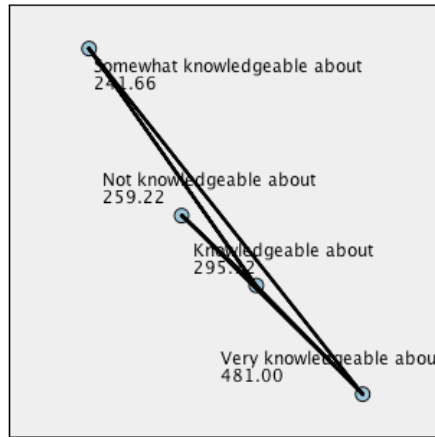

Each node shows the sample average rank of Know_LevelBPMN.

Sample1-Sample2	Test Statistic	Std. Error	Std. Test Statistic	Sig.	Adj.Sig.
Somewhat knowledgeable about-Not knowledgeable about	17.564	14.036	1.251	.211	1.000
Somewhat knowledgeable about-Knowledgeable about	-53.457	21.087	-2.535	.011	.067
Somewhat knowledgeable about-Very knowledgeable about	-239.340	104.363	-2.293	.022	.131
Not knowledgeable about-Knowledgeable about	-35.893	21.744	-1.651	.099	.593
Not knowledgeable about-Very knowledgeable about	-221.776	104.497	-2.122	.034	.203
Knowledgeable about-Very knowledgeable about	-185.883	105.676	-1.759	.079	.471

Each row tests the null hypothesis that the Sample 1 and Sample 2 distributions are the same. Asymptotic significances (2-sided tests) are displayed. The significance level is .05.

Figure 69 Pairwise comparisons of BPMN 2.0 knowledge - perceived ease of understanding

Table 49 Homogeneous subsets of perceived ease of understanding by BPMN 2.0 knowledge

Homogeneous Subsets based on Perceived Ease of Understanding				
		Subset		
		1	2	3
Sample¹	Somewhat knowledgeable about	241.660		
	Not knowledgeable about	259.224	259.224	
	Knowledgeable about		295.117	
	Very knowledgeable about			481.000
Test Statistic		1.528	2.585	²
Sig. (2-sided test)		.216	.108	.
Adjusted Sig. (2-sided test)		.386	.204	.
Homogeneous subsets are based on asymptotic significances. The significance level is .05.				
¹ Each cell shows the sample average rank of Perceived Ease of Understanding .				
² Unable to compute because the subset contains only one sample.				

APPENDIX M: THE INFLUENCE OF THEORETICAL KNOWLEDGE ON BP MODELING AND BPMN 2.0

THE INFLUENCE OF THEORETICAL KNOWLEDGE ON BP MODELING AND BPMN 2.0

Table 50 Kruskal-Wallis test results for understandability variables by theoretical knowledge on BP modeling and BPMN 2.0

Hypothesis Test Summary

	Null Hypothesis	Test	Sig.	Decision
1	The distribution of Unders. Task Effectiveness is the same across categories of PM_TKnow_Score_Outof_5.	Independent-Samples Kruskal-Wallis Test	.003	Reject the null hypothesis.
2	The distribution of Unders. Task Efficiency is the same across categories of PM_TKnow_Score_Outof_5.	Independent-Samples Kruskal-Wallis Test	.648	Retain the null hypothesis.
3	The distribution of Perceived Usefulness for Unders. is the same across categories of PM_TKnow_Score_Outof_5.	Independent-Samples Kruskal-Wallis Test	.236	Retain the null hypothesis.
4	The distribution of Perceived Ease of Understanding is the same across categories of PM_TKnow_Score_Outof_5.	Independent-Samples Kruskal-Wallis Test	.827	Retain the null hypothesis.

Asymptotic significances are displayed. The significance level is .05.

Independent-Samples Kruskal-Wallis Test

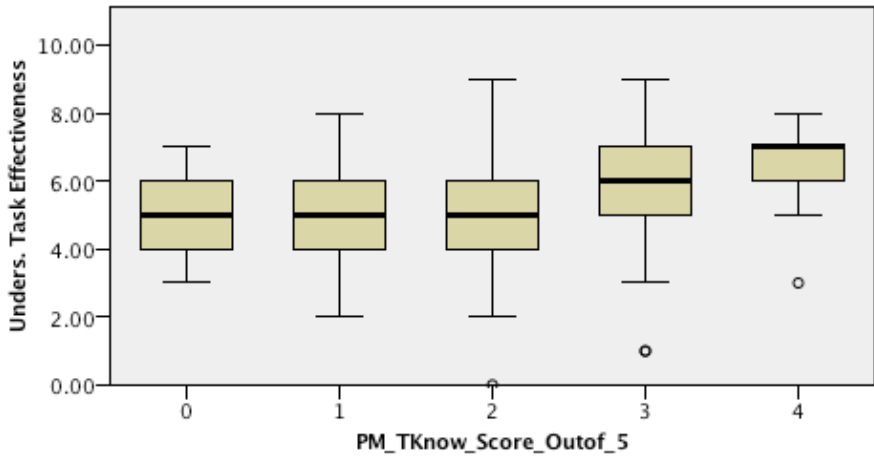

Total N	390
Test Statistic	16.354
Degrees of Freedom	4
Asymptotic Sig. (2-sided test)	.003

1. The test statistic is adjusted for ties.

Figure 70 Independent samples test view of theoretical knowledge on BP modeling and BPMN 2.0 - understandability task effectiveness

Pairwise Comparisons ...

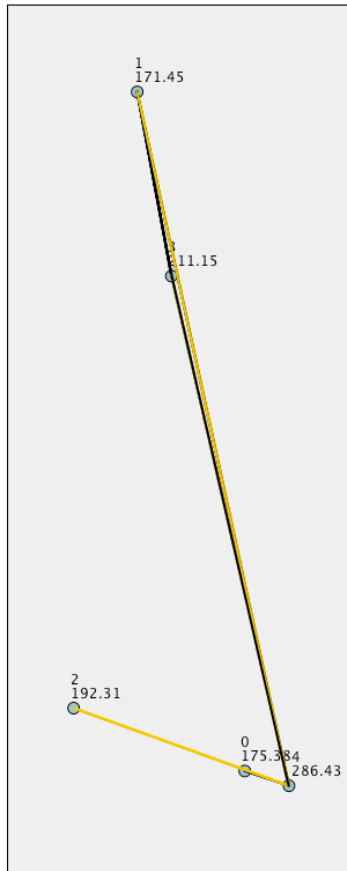

Each node shows the sample average rank of PM_TKnow_Score_Outof_5.

Sample1-Sample2	Test Statistic	Std. Error	Std. Test Statistic	Sig.	Adj.Sig.
1-0	3.927	56.518	.069	.945	1.000
1-2	-20.861	14.140	-1.475	.140	1.000
1-3	-39.703	15.604	-2.544	.011	.109
1-4	-114.981	31.685	-3.629	.000	.003
0-2	-16.934	56.024	-.302	.762	1.000
0-3	-35.776	56.412	-.634	.526	1.000
0-4	-111.054	62.791	-1.769	.077	.770
2-3	-18.842	13.707	-1.375	.169	1.000
2-4	-94.120	30.795	-3.056	.002	.022
3-4	-75.278	31.494	-2.390	.017	.168

Each row tests the null hypothesis that the Sample 1 and Sample 2 distributions are the same. Asymptotic significances (2-sided tests) are displayed. The significance level is .05.

Figure 71 Pairwise comparisons of theoretical knowledge on BP modeling and BPMN 2.0 - understandability task effectiveness

Hypothesis Test Summary			
Null Hypothesis	Test	Sig.	Decision
1 The distribution of Unders. Task Effectiveness is the same across categories of Know_LevelBPMN.	Independent-Samples Kruskal-Wallis Test	.869	Retain the null hypothesis.
2 The distribution of Unders. Task Efficiency is the same across categories of Know_LevelBPMN.	Independent-Samples Kruskal-Wallis Test	.918	Retain the null hypothesis.
3 The distribution of Perceived Usefulness for Unders. is the same across categories of Know_LevelBPMN.	Independent-Samples Kruskal-Wallis Test	.067	Retain the null hypothesis.
4 The distribution of Perceived Ease of Understanding is the same across categories of Know_LevelBPMN.	Independent-Samples Kruskal-Wallis Test	.210	Retain the null hypothesis.
Asymptotic significances are displayed. The significance level is .05.			
Experiment 1			

Hypothesis Test Summary			
Null Hypothesis	Test	Sig.	Decision
1 The distribution of Unders. Task Effectiveness is the same across categories of PM_TKnow_Score_Outof_5.	Independent-Samples Kruskal-Wallis Test	.001	Reject the null hypothesis.
2 The distribution of Unders. Task Efficiency is the same across categories of PM_TKnow_Score_Outof_5.	Independent-Samples Kruskal-Wallis Test	.122	Retain the null hypothesis.
3 The distribution of Perceived Usefulness for Unders. is the same across categories of PM_TKnow_Score_Outof_5.	Independent-Samples Kruskal-Wallis Test	.684	Retain the null hypothesis.
4 The distribution of Perceived Ease of Understanding is the same across categories of PM_TKnow_Score_Outof_5.	Independent-Samples Kruskal-Wallis Test	.505	Retain the null hypothesis.
Asymptotic significances are displayed. The significance level is .05.			
Experiment 2			

Hypothesis Test Summary			
Null Hypothesis	Test	Sig.	Decision
1 The distribution of Unders. Task Effectiveness is the same across categories of PM_TKnow_Score_Outof_5.	Independent-Samples Kruskal-Wallis Test	.598	Retain the null hypothesis.
2 The distribution of Unders. Task Efficiency is the same across categories of PM_TKnow_Score_Outof_5.	Independent-Samples Kruskal-Wallis Test	.353	Retain the null hypothesis.
3 The distribution of Perceived Usefulness for Unders. is the same across categories of PM_TKnow_Score_Outof_5.	Independent-Samples Kruskal-Wallis Test	.003	Reject the null hypothesis.
4 The distribution of Perceived Ease of Understanding is the same across categories of PM_TKnow_Score_Outof_5.	Independent-Samples Kruskal-Wallis Test	.056	Retain the null hypothesis.
Asymptotic significances are displayed. The significance level is .05.			
Experiment 3			

Figure 79 Kruskal-Wallis test results for understandability variables by theoretical knowledge on process modeling and BPMN 2.0 (for each experiment)



APPENDIX O: THE INFLUENCE OF USING DIFFERENT PROCESS MODELS

THE INFLUENCE OF USING DIFFERENT PROCESS MODELS

Hypothesis Test Summary				Hypothesis Test Summary			
Null Hypothesis	Test	Sig.	Decision	Null Hypothesis	Test	Sig.	Decision
1 The distribution of Unders. Task Effectiveness is the same across categories of Modularity Representation.	Independent-Samples Kruskal-Wallis Test	.999	Retain the null hypothesis.	1 The distribution of Unders. Task Effectiveness is the same across categories of Modularity Representation.	Independent-Samples Kruskal-Wallis Test	.093	Retain the null hypothesis.
2 The distribution of Unders. Task Efficiency is the same across categories of Modularity Representation.	Independent-Samples Kruskal-Wallis Test	.360	Retain the null hypothesis.	2 The distribution of Unders. Task Efficiency is the same across categories of Modularity Representation.	Independent-Samples Kruskal-Wallis Test	.228	Retain the null hypothesis.
3 The distribution of Perceived Usefulness for Unders. is the same across categories of Modularity Representation.	Independent-Samples Kruskal-Wallis Test	.860	Retain the null hypothesis.	3 The distribution of Perceived Usefulness for Unders. is the same across categories of Modularity Representation.	Independent-Samples Kruskal-Wallis Test	.030	Reject the null hypothesis.
4 The distribution of Perceived Ease of Understanding is the same across categories of Modularity Representation.	Independent-Samples Kruskal-Wallis Test	.267	Retain the null hypothesis.	4 The distribution of Perceived Ease of Understanding is the same across categories of Modularity Representation.	Independent-Samples Kruskal-Wallis Test	.000	Reject the null hypothesis.
Asymptotic significances are displayed. The significance level is .05.				Asymptotic significances are displayed. The significance level is .05.			
Process Model A				Process Model B			

Figure 80 Kruskal-Wallis test results for understandability variables by modularity representation (for each process model)

Hypothesis Test Summary				Hypothesis Test Summary			
Null Hypothesis	Test	Sig.	Decision	Null Hypothesis	Test	Sig.	Decision
1 The distribution of UndQ_LocScore is the same across categories of Modularity Representation.	Independent-Samples Kruskal-Wallis Test	.809	Retain the null hypothesis.	1 The distribution of UndQ_LocScore is the same across categories of Modularity Representation.	Independent-Samples Kruskal-Wallis Test	.011	Reject the null hypothesis.
2 The distribution of UndQ_GloScore is the same across categories of Modularity Representation.	Independent-Samples Kruskal-Wallis Test	.677	Retain the null hypothesis.	2 The distribution of UndQ_GloScore is the same across categories of Modularity Representation.	Independent-Samples Kruskal-Wallis Test	.993	Retain the null hypothesis.
3 The distribution of UndQ_PureLocScore is the same across categories of Modularity Representation.	Independent-Samples Kruskal-Wallis Test	.895	Retain the null hypothesis.	3 The distribution of UndQ_PureLocScore is the same across categories of Modularity Representation.	Independent-Samples Kruskal-Wallis Test	.000	Reject the null hypothesis.
4 The distribution of UndQ_PureGloScore is the same across categories of Modularity Representation.	Independent-Samples Kruskal-Wallis Test	.542	Retain the null hypothesis.	4 The distribution of UndQ_PureGloScore is the same across categories of Modularity Representation.	Independent-Samples Kruskal-Wallis Test	.101	Retain the null hypothesis.
5 The distribution of UndQ_GloLocScore is the same across categories of Modularity Representation.	Independent-Samples Kruskal-Wallis Test	.574	Retain the null hypothesis.	5 The distribution of UndQ_GloLocScore is the same across categories of Modularity Representation.	Independent-Samples Kruskal-Wallis Test	.232	Retain the null hypothesis.
6 The distribution of UndQ_CntScore is the same across categories of Modularity Representation.	Independent-Samples Kruskal-Wallis Test	.952	Retain the null hypothesis.	6 The distribution of UndQ_CntScore is the same across categories of Modularity Representation.	Independent-Samples Kruskal-Wallis Test	.016	Reject the null hypothesis.
7 The distribution of UndQ_ResScore is the same across categories of Modularity Representation.	Independent-Samples Kruskal-Wallis Test	.846	Retain the null hypothesis.	7 The distribution of UndQ_ResScore is the same across categories of Modularity Representation.	Independent-Samples Kruskal-Wallis Test	.182	Retain the null hypothesis.
8 The distribution of UndQ_InfScore is the same across categories of Modularity Representation.	Independent-Samples Kruskal-Wallis Test	.329	Retain the null hypothesis.	8 The distribution of UndQ_InfScore is the same across categories of Modularity Representation.	Independent-Samples Kruskal-Wallis Test	.896	Retain the null hypothesis.
9 The distribution of UndQ_PureCntScore is the same across categories of Modularity Representation.	Independent-Samples Kruskal-Wallis Test	.273	Retain the null hypothesis.	9 The distribution of UndQ_PureCntScore is the same across categories of Modularity Representation.	Independent-Samples Kruskal-Wallis Test	.002	Reject the null hypothesis.
10 The distribution of UndQ_PureResInfScore is the same across categories of Modularity Representation.	Independent-Samples Kruskal-Wallis Test	.738	Retain the null hypothesis.	10 The distribution of UndQ_PureResInfScore is the same across categories of Modularity Representation.	Independent-Samples Kruskal-Wallis Test	.143	Retain the null hypothesis.
11 The distribution of UndQ_CntResInfScore is the same across categories of Modularity Representation.	Independent-Samples Kruskal-Wallis Test	.154	Retain the null hypothesis.	11 The distribution of UndQ_CntResInfScore is the same across categories of Modularity Representation.	Independent-Samples Kruskal-Wallis Test	.414	Retain the null hypothesis.
Asymptotic significances are displayed. The significance level is .05.				Asymptotic significances are displayed. The significance level is .05.			
Process Model A				Process Model B			

Figure 81 Kruskal-Wallis test results for further analysis of understandability task effectiveness by modularity representation (for each process model)

Hypothesis Test Summary				Hypothesis Test Summary					
	Null Hypothesis	Test	Sig.	Decision		Null Hypothesis	Test	Sig.	Decision
1	The distribution of UndQ_LocEff_CORR is the same across categories of Modularity Representation.	Independent-Samples Kruskal-Wallis Test	.127	Retain the null hypothesis.	1	The distribution of UndQ_LocEff_CORR is the same across categories of Modularity Representation.	Independent-Samples Kruskal-Wallis Test	.082	Retain the null hypothesis.
2	The distribution of UndQ_GloLocEff_CORR is the same across categories of Modularity Representation.	Independent-Samples Kruskal-Wallis Test	.900	Retain the null hypothesis.	2	The distribution of UndQ_GloLocEff_CORR is the same across categories of Modularity Representation.	Independent-Samples Kruskal-Wallis Test	.777	Retain the null hypothesis.
3	The distribution of UndQ_PureLocEff_CORR is the same across categories of Modularity Representation.	Independent-Samples Kruskal-Wallis Test	.256	Retain the null hypothesis.	3	The distribution of UndQ_PureLocEff_CORR is the same across categories of Modularity Representation.	Independent-Samples Kruskal-Wallis Test	.093	Retain the null hypothesis.
4	The distribution of UndQ_PureGloEff_CORR is the same across categories of Modularity Representation.	Independent-Samples Kruskal-Wallis Test	.232	Retain the null hypothesis.	4	The distribution of UndQ_PureGloEff_CORR is the same across categories of Modularity Representation.	Independent-Samples Kruskal-Wallis Test	.882	Retain the null hypothesis.
5	The distribution of UndQ_GloLocEff_CORR is the same across categories of Modularity Representation.	Independent-Samples Kruskal-Wallis Test	.484	Retain the null hypothesis.	5	The distribution of UndQ_GloLocEff_CORR is the same across categories of Modularity Representation.	Independent-Samples Kruskal-Wallis Test	.848	Retain the null hypothesis.
6	The distribution of UndQ_CntEff_CORR is the same across categories of Modularity Representation.	Independent-Samples Kruskal-Wallis Test	.143	Retain the null hypothesis.	6	The distribution of UndQ_CntEff_CORR is the same across categories of Modularity Representation.	Independent-Samples Kruskal-Wallis Test	.071	Retain the null hypothesis.
7	The distribution of UndQ_ResEff_CORR is the same across categories of Modularity Representation.	Independent-Samples Kruskal-Wallis Test	.586	Retain the null hypothesis.	7	The distribution of UndQ_ResEff_CORR is the same across categories of Modularity Representation.	Independent-Samples Kruskal-Wallis Test	.125	Retain the null hypothesis.
8	The distribution of UndQ_InEff_CORR is the same across categories of Modularity Representation.	Independent-Samples Kruskal-Wallis Test	.421	Retain the null hypothesis.	8	The distribution of UndQ_InEff_CORR is the same across categories of Modularity Representation.	Independent-Samples Kruskal-Wallis Test	.418	Retain the null hypothesis.
9	The distribution of UndQ_PureCntEff_CORR is the same across categories of Modularity Representation.	Independent-Samples Kruskal-Wallis Test	.936	Retain the null hypothesis.	9	The distribution of UndQ_PureCntEff_CORR is the same across categories of Modularity Representation.	Independent-Samples Kruskal-Wallis Test	.032	Reject the null hypothesis.
10	The distribution of UndQ_PureResInEff_CORR is the same across categories of Modularity Representation.	Independent-Samples Kruskal-Wallis Test	.800	Retain the null hypothesis.	10	The distribution of UndQ_PureResInEff_CORR is the same across categories of Modularity Representation.	Independent-Samples Kruskal-Wallis Test	.984	Retain the null hypothesis.
11	The distribution of UndQ_CntResInEff_CORR is the same across categories of Modularity Representation.	Independent-Samples Kruskal-Wallis Test	.000	Reject the null hypothesis.	11	The distribution of UndQ_CntResInEff_CORR is the same across categories of Modularity Representation.	Independent-Samples Kruskal-Wallis Test	.081	Retain the null hypothesis.

Asymptotic significances are displayed. The significance level is .05.

Process Model A **Process Model B**

Figure 82 Kruskal-Wallis test results for further analysis of understandability task efficiency by modularity representation (for each process model)

Hypothesis Test Summary				Hypothesis Test Summary					
	Null Hypothesis	Test	Sig.	Decision		Null Hypothesis	Test	Sig.	Decision
1	The distribution of Unders. Task Effectiveness is the same across categories of Presentation Medium.	Independent-Samples Kruskal-Wallis Test	.169	Retain the null hypothesis.	1	The distribution of Unders. Task Effectiveness is the same across categories of Presentation Medium.	Independent-Samples Kruskal-Wallis Test	.050	Retain the null hypothesis.
2	The distribution of Unders. Task Efficiency is the same across categories of Presentation Medium.	Independent-Samples Kruskal-Wallis Test	.134	Retain the null hypothesis.	2	The distribution of Unders. Task Efficiency is the same across categories of Presentation Medium.	Independent-Samples Kruskal-Wallis Test	.388	Retain the null hypothesis.
3	The distribution of Perceived Usefulness for Unders. is the same across categories of Presentation Medium.	Independent-Samples Kruskal-Wallis Test	.002	Reject the null hypothesis.	3	The distribution of Perceived Usefulness for Unders. is the same across categories of Presentation Medium.	Independent-Samples Kruskal-Wallis Test	.008	Reject the null hypothesis.
4	The distribution of Perceived Ease of Understanding is the same across categories of Presentation Medium.	Independent-Samples Kruskal-Wallis Test	.038	Reject the null hypothesis.	4	The distribution of Perceived Ease of Understanding is the same across categories of Presentation Medium.	Independent-Samples Kruskal-Wallis Test	.013	Reject the null hypothesis.

Asymptotic significances are displayed. The significance level is .05.

Process Model A **Process Model B**

Figure 83 Kruskal-Wallis test results for understandability variables by presentation medium (for each process model)

CURRICULUM VITAE

PERSONAL INFORMATION

Ahmet Dikici was born in Denizli, Turkey in 1980. He received the B.S. in Computer Engineering in 2002 and the M.S. in Software Engineering in 2005 from Middle East Technical University. He has 14 years experience as a software engineer, project team leader, quality manager and project manager. His expertise lies in software development and management processes with a special focus on software quality. His research interests include business process management, process modeling and software engineering. You can contact him at ahmetdikici@gmail.com

WORK EXPERIENCE

Year	Place	Enrollment
2010-Present	TÜBİTAK BİLGEM YTE	Project Manager
2012-2013	TÜBİTAK BİLGEM YTE	Unit Manager
2009-2010	TÜBİTAK UEKAE / G222	Project Manager Assistant
2006-2009	TÜBİTAK UEKAE / G222	Project Team Leader
2005-2006	Turkish Air Forces	Second Lieutenant
2003-2005	TÜBİTAK UEKAE	Software Engineer
2002-2002	HAVELSAN EHSİM	Software Engineer

SELECTED PUBLICATIONS

Turetken O., Rompen T., Vanderfeesten I., Dikici, A., & van Moll, J. (2016). The effect of modularity representation and presentation medium on the understandability of business process models in BPMN. In 14th International Conference on Business Process Management. Rio de Janeiro, Brazil. - *To be published*

Dikici, A., Turetken, O., & Demirors, O. (2012). A Case Study on Measuring Process Quality: Lessons Learned. In 38th EUROMICRO Conference on Software Engineering and Advanced Applications (pp. 294–297). <http://doi.org/10.1109/SEAA.2012.26>

Dikici, A., & Demirors, O. (2012). Süreç Kalitesi Ölçümünde Süreç Modelindeki Soyutlama Seviyesinin Önemi. In 6. Ulusal Yazılım Mühendisliği Sempozyumu (pp. 161–168).

CERTIFICATES

2015 - TOGAF 9 Certified, Certification Id: 96120, The Open Group

2010 - PMP (Project Management Professional), PMP Number: 1322366, PMI

2010 - COSMIC V3.0 Software Functional Size Measurer; COSMIC

2009 - CSM (Certified ScrumMaster), Certification ID: 49413, ScrumAlliance

2006 - SCWCD (Sun Certified Web Component Developer)

2004 - SCJP (Sun Certified Java Programmer)