

**İZMİR KÂTİP ÇELEBİ UNIVERSITY ★ GRADUATE SCHOOL OF  
NATURAL AND APPLIED SCIENCES**

**DEVELOPMENT OF VIBRATION PERFORMANCES OF HYBRID  
LAMINATED COMPOSITE MATERIALS BY USING STOCHASTIC  
METHODS**



**M.Sc. THESIS**

**Melih SAVRAN**

**Department of Mechanical Engineering**

**Thesis Advisor: Assist. Prof. Dr. Levent AYDIN**

**JUNE 2017**

**İZMİR KÂTİP ÇELEBİ UNIVERSITY ★ GRADUATE SCHOOL OF  
NATURAL AND APPLIED SCIENCES**

**DEVELOPMENT OF VIBRATION PERFORMANCES OF HYBRID  
LAMINATED COMPOSITE MATERIALS BY USING STOCHASTIC  
METHODS**



**M.Sc. THESIS**

**Melih SAVRAN**

**(Y130105015)**

**Department of Mechanical Engineering**

**Thesis Advisor: Assist. Prof. Dr. Levent AYDIN**

**JUNE 2017**

**İZMİR KÂTİP ÇELEBİ ÜNİVERSİTESİ ★ FEN BİLİMLERİ ENSTİTÜSÜ**

**TABAKALI HİBRİT KOMPOZİT MALZEMELERİN TİTREŞİM  
PERFORMANSLARININ STOKASTİK OPTİMİZASYON YÖNTEMLERİ  
KULLANILARAK GELİŞTİRİLMESİ**

**YÜKSEK LİSANS TEZİ**

**Melih SAVRAN**

**(Y130105015)**

**Makina Mühendisliği Anabilim Dalı**

**Tez Danışmanı: Yrd. Doç. Dr. Levent AYDIN**

**HAZİRAN 2017**

**Melih SAVRAN**, a **M.Sc.** student of **İzmir Katip Çelebi University** student ID Y130105015, successfully defended the **thesis** entitled “**Development of vibration performance of hybrid laminated composite material by using stochastic methods**”, which he prepared after fulfilling the requirements specified in the associated legislations, before the jury whose signatures are below.

**Thesis Advisor :**      **Assist. Prof. Dr. Levent AYDIN**  
İzmir Katip Çelebi University

**Jury Members :**      **Prof. Dr. M. Evren TOYGAR**  
Dokuz Eylül University

**Prof. Dr. Buket OKUTAN BABA**  
İzmir Katip Çelebi University

**Date of Submission :** 03.07.2017  
**Date of Defense :** 05.06.2017

## ACKNOWLEDGMENTS

I would like to express my sincere gratitude to my supervisor Assist. Prof. Dr. Levent Aydın for his advises, guidance, support, encouragement, and inspiration through the thesis. His patience and kindness are greatly appreciated. I have been fortunate to have Dr. Aydın as my advisor and I consider it an honor working with him.

I am also grateful to my friends for their support, encouragement and contributions.

Lastly, I would like to thank my family who have supported and encouraged me during my graduate studies.

June 2017

Melih Savran



# TABLE OF CONTENTS

<b>ACKNOWLEDGEMENTS</b> .....	<b>IV</b>
<b>TABLE OF CONTENTS</b> .....	<b>V</b>
<b>LIST OF TABLES</b> .....	<b>VII</b>
<b>LIST OF FIGURES</b> .....	<b>X</b>
<b>ABSTRACT</b> .....	<b>XI</b>
<b>ÖZET</b> .....	<b>XIII</b>
<b>CHAPTER 1. INTRODUCTION</b> .....	<b>1</b>
1.1. Literature Survey .....	1
1.2. Objectives .....	5
<b>CHAPTER 2. COMPOSITE MATERIALS</b> .....	<b>6</b>
2.1. Introduction.....	6
2.2. Classification of Composites .....	8
2.3. Applications of Composite Materials .....	13
<b>CHAPTER 3. MECHANICS OF COMPOSITE MATERIALS</b> .....	<b>17</b>
3.1. Classical Lamination Theory .....	17
3.2. Vibration Theory of Laminated Composite Plates .....	22
<b>CHAPTER 4. OPTIMIZATION</b> .....	<b>25</b>
5.1 Single-Objective Optimization .....	26
5.2 Multi-Objective Optimization .....	26
5.3. Stochastic Optimization Algorithms .....	27
5.3.1. Diferential Evolution Algorithm (DE).....	27
5.3.2. Nelder Mead Algorithm (NM).....	28
5.3.3. Random Search Algorithm (RS).....	30
5.3.3. Simulated Annealing Algorithm (SA) .....	31

<b>CHAPTER 5. STOCHASTIC OPTIMIZATION OF NON-HYBRID LAMINATED COMPOSITE FOR MAXIMUM FUNDAMENTAL FREQUENCY .....</b>	<b>34</b>
<b>CHAPTER 6. STOCHASTIC OPTIMIZATION OF GRAPHITE- GLASS/EPOXY INTERPLY HYBRID LAMINATED COMPOSITE FOR MAXIMUM FUNDAMENTAL FREQUENCY AND MINIMUM COST .....</b>	<b>44</b>
<b>CHAPTER 7. STOCHASTIC OPTIMIZATION OF GRAPHITE- FLAX/EPOXY INTERPLY HYBRID LAMINATED COMPOSITE FOR MAXIMUM FUNDAMENTAL FREQUENCY AND MINIMUM COST .....</b>	<b>59</b>
<b>CHAPTER 8. CONCLUSION .....</b>	<b>65</b>
<b>REFERENCES .....</b>	<b>68</b>

# LIST OF TABLES

<u>Table</u>	<u>Page</u>
<b>Table 2.1:</b> Specific Modulus and Specific Strength Values of Typical Fibers, Composites and Bulk Metals .....	7
<b>Table 2.2:</b> Comparison between plant fibers and E-glass .....	10
<b>Table 2.3:</b> Differences between thermosets and thermoplastics .....	11
<b>Table 2.4:</b> Comparison of Conventional Matrix Materials .....	12
<b>Table 2.5:</b> Advantages and Disadvantages of Reinforcing fibers .....	13
<b>Table 2.6:</b> Application of natural fibres in automotive parts .....	15
<b>Table 4.1:</b> Four optimization methods options.....	33
<b>Table 5.1:</b> Glass-epoxy, graphite-epoxy and flax-epoxy mechanical Properties .....	35
<b>Table 5.2:</b> Comparison of optimum stacking sequences design in terms of fundamental frequencies for 8-layered symmetric non-hybrid graphite/epoxy laminates with $15^0$ increment .....	38
<b>Table 5.3:</b> Comparison of optimum stacking sequences design in terms of fundamental frequencies for 8-layered symmetric-balance non-hybrid graphite/epoxy laminates with $15^0$ increment.....	38
<b>Table 5.4:</b> Comparison of optimum stacking sequences design in terms of fundamental frequencies for 8-layered symmetric-balance non-hybrid graphite/epoxy laminates with integer design variable .....	39
<b>Table 5.5:</b> Comparison of optimum stacking sequences design in terms of fundamental frequencies for 16-layered symmetric non-hybrid glass/epoxylaminates with $45^0$ increment .....	40
<b>Table 5.6:</b> Comparison of optimum stacking sequences design in terms of fundamental frequencies for 16-layered symmetric-balance non-hybrid glass/epoxy laminates with $45^0$ increment .....	41



<b>Table 5.7:</b> Comparison of optimum stacking sequences design in terms of fundamental frequencies for 16-layered symmetric-balance non-hybrid glass/epoxy laminates with integer design variables .....	41
<b>Table 5.8:</b> Comparison of optimum stacking sequences design in terms of fundamental frequencies for 16-layered symmetric non-hybrid flax/epoxy laminates with $45^0$ increment .....	42
<b>Table 5.9:</b> Comparison of optimum stacking sequences design in terms of fundamental frequencies for 16-layered symmetric-balance non-hybrid flax/epoxy laminates with $45^0$ increment .....	43
<b>Table 6.1:</b> Comparison of optimum stacking sequences design in terms of index F and corresponding values on fundamental frequencies and cost for 8-layered symmetric hybrid graphite-glass/epoxy laminates with $15^0$ increment.....	48
<b>Table 6.2:</b> Comparison of optimum stacking sequences design in terms of index F and corresponding values on fundamental frequencies and cost for 8-layered symmetric-balance hybrid graphite-glass/epoxy laminates with $15^0$ increment.....	49
<b>Table 6.3:</b> Comparison of optimum stacking sequences design in terms of index F and corresponding values on fundamental frequencies and cost for 28-layered symmetric-balance hybrid graphite-glass/epoxy laminates with $15^0$ increment.....	51
<b>Table 6.4:</b> Comparison of optimum stacking sequences design in terms of index F and corresponding values on fundamental frequencies and cost for 48-layered symmetric-balance hybrid graphite-glass/epoxy	

laminates with  $15^0$  increment .....53

**Table 6.5:** Comparison of optimum stacking sequences design  
in terms of index F and corresponding values on  
fundamental frequencies and cost for 8/28/48-layered  
symmetric-balance hybrid graphite-glass/epoxy  
laminates with cont/ $1^0/5^0/30^0$  increments .....55

**Table 7.1:** Comparison of optimum stacking sequences design  
in terms of index F and corresponding values on  
fundamental frequencies and cost for 8-layered  
symmetric hybrid graphite-flax/epoxy  
laminates with  $15^0$  increment .....61

**Table 7.2:** Comparison of optimum stacking sequences design  
in terms of index F and corresponding values on  
fundamental frequencies and cost for 28-layered  
symmetric hybrid graphite-flax/epoxy  
laminates with  $15^0$  increment .....62

## LIST OF FIGURES

<u>Figure</u>	<u>Page</u>
<b>Figure 2.1:</b> Specific strength as a function of time of use of materials.....	7
<b>Figure 2.2:</b> Types of composites based on reinforcement Shape .....	8
<b>Figure 2.3:</b> Cost per weight comparison between glass, graphite and natural fibres.....	11
<b>Figure 2.4:</b> PFRPs accounted for 1.9% of the 2.4 million tonne EU FRP market in 2010.....	13
<b>Figure 2.5:</b> Use of fiber-reinforced polymer composites in Boing 787 .....	14
<b>Figure 3.1:</b> A thin fiber-reinforced laminated composite subjected to in plane loading.....	18
<b>Figure 3.2:</b> Coordinate locations of plies in a laminate .....	18
<b>Figure 3.3:</b> Resultant forces and moments on a laminate .....	20
<b>Figure 3.4:</b> Geometry, coordinate system, and simply supported boundary conditions for a rectangular plate .....	23
<b>Figure 4.1:</b> Flowchart of the DE algorithm.....	28
<b>Figure 4.2:</b> Flowchart of the NM algorithm.....	29
<b>Figure 4.3:</b> Flowchart of the RS algorithm .....	31
<b>Figure 4.4:</b> Flowchart of the SA algorithm .....	32
<b>Figure 5.1:</b> Laminated plate consisting of multiple laminate.....	34
<b>Figure 6.1:</b> Fundamental frequency and cost of laminated composite for 28 and 48 ply depends on aspect ratio and number of graphite ply .....	57
<b>Figure 6.2:</b> Percent reduction of fundamental frequency and cost of laminated composite for 28 and 48 ply depends on aspect ratio and number of graphite ply .....	58

# ABSTRACT

## **Development of vibration performances of hybrid laminated composite materials by using stochastic methods**

In recent years, laminated composites are fairly utilized in marine, automotive, aerospace, military and other engineering applications because of their high specific modulus (ratio between the young modulus and the density) and high specific strength (ratio between strength and density). In addition to these features, fiber reinforced composites have inherent tailorability such as fiber orientation and stacking sequence and provide great possibilities to designers against isotropic materials. Determination of the fundamental frequency performance of laminated composite plate is crucial for the design of the composite structures. Especially, in dynamical engineering systems, fundamental frequency have to be taken into account in order to prevent resonance arising from external excitations. Laminated composite materials can fulfill this requirement with an appropriate stacking sequence by using optimization methods.

In this thesis, the optimum designs of non-hybrid and hybrid laminated composite plates have been investigated. The considered laminated plate is simply supported on four sides. In non-hybrid cases, fundamental frequency is taken as objective function and fiber orientation angles of the laminated composites are taken as discrete and continuous design variables. The optimization has been conducted using graphite/epoxy, glass/epoxy and flax/epoxy materials for various aspect ratios (0.2-2). Single objective optimization formulation have been used for mathematical verification of model problems. In hybrid cases, multi objective approach is considered to maximize the fundamental frequency and minimize the cost simultaneously. The design variables of the multi objective optimization problems are selected as fiber orientation angles, the number of outer layers ( $N_o$ ) having high-stiffness and more expensive and the number of inner layers ( $N_i$ ) having low-stiffness and inexpensive. Multi objective optimization has been carried out using hybrid graphite-glass/epoxy and graphite-flax/epoxy materials for various aspect ratios (0.2-2).

Ecological approach in automotive, aerospace and marine industries have stated that natural fibers (especially flax) are of great importance for their use as alternative reinforcing materials to glass fibers because of their inherent good vibration and cost

performances. In this regard, the present study is an attempt to show the usage of flax fiber as an alternative to E-glass in interply hybrid composite structures in terms of fundamental frequency and cost. Stacking sequences design and optimization of laminated composites based on Differential Evolution (DE), Nelder Mead (NM), Random Search (RS) and Simulated Annealing (SA) algorithms are considered. The results show that the proposed optimum graphite-flax/epoxy interply composite structure give better than the result of graphite-glass/epoxy in terms of maximum fundamental frequency and minimum cost. It is also found that DE, NM and SA algorithms show superior or at least comparable performance versus Ant Colony Optimization (ACO), Simulated Annealing (SA) and Genetic Algorithm (GA) in the literature for the same laminated structure design problems.



## ÖZET

### **Tabakalı hibrit kompozit malzemelerin titreşim performanslarının stokastik optimizasyon yöntemleri kullanılarak geliştirilmesi**

Son yıllarda, fiber katkılı tabakalı kompozitler, yüksek özgül modülü (elastisite modülü ve yoğunluk arasındaki oran) ve yüksek özgül mukavemeti (mukavemet ile yoğunluk arasındaki oran) nedeniyle deniz, havacılık, otomotiv ve diğer mühendislik uygulamalarında sıklıkla kullanılmaktadır. Bu özelliklere ek olarak, fiber takviyeli tabakalı kompozit malzemeler, fiber oryantasyonu ve tabaka dizilimi gibi doğal özelliklere sahiptir ve tasarımcılara izotropik malzemelere karşı büyük avantajlar sağlar. Kompozit plakaların doğal frekans performansının belirlenmesi, kompozit yapıların tasarımı için oldukça önemlidir. Özellikle, dinamik mühendislik sistemlerinde, dış yüklemelerden kaynaklanan rezonansı önlemek için doğal frekans dikkate alınmalıdır. Tabakalı kompozit malzemelerde optimizasyon yöntemleri kullanarak uygun tabaka dizilimlerinde arzulanan doğal frekans değerleri elde edilebilir.

Bu tezde, hibrid ve hibrit olmayan tabakalı kompozit plakaların optimum tasarımları araştırılmıştır. Düşünülen tabakalı kompozit plaka dört kenarından basit mesnet ile desteklenmektedir. Hibrid olmayan durumlarda, doğal frekans amaç fonksiyon olarak, tabakalı kompozitlerin fiber yönelme açısı ise tasarım değişkeni olarak alınır. Optimizasyon, grafit / epoksi, cam / epoksi ve keten / epoksi malzemeler kullanılarak, çeşitli en-boy oranlarındaki (0.2-2) dikdörtgen plakalar için gerçekleştirilmiştir. Model problemlerinin matematiksel doğrulanması için tek amaçlı optimizasyon yöntemi kullanılmıştır. Hibrit durumlarda, çok amaçlı optimizasyon yaklaşımı, temel frekansı en üst düzeye çıkarmak ve aynı anda maliyeti en aza indirmek için düşünülmüştür. Çok amaçlı optimizasyon problemlerinde; fiber oryantasyon açıları, yüksek rijitliğe sahip ve pahalı dış katmanların ( $N_o$ ) sayısı ve düşük rijitliğe sahip ve ucuz iç katmanların ( $N_i$ ) sayısı tasarım değişkenleri olarak seçilmiştir. Çeşitli en boy oranlarında ki (0.2-2) dikdörtgen plakalar için hibrit grafit-cam / epoksi ve grafit-keten / epoksi malzemeleri kullanılarak çok amaçlı optimizasyon yapılmıştır.

Otomotiv, havacılık ve denizcilik endüstrilerinde ki çevreci yaklaşımlar, doğal elyafların (özellikle keten) doğal frekans ve maliyet performanslarından dolayı cam elyaflara alternatif takviye malzemeleri olarak kullanılmasının büyük önem taşıdığını

ifade etmektedir. Bu bağlamda, bu çalışma, doğal frekans ve maliyet açısından, tabakalar arası hibrit kompozit yapılarda alternative malzeme olarak cam elyaf yerine keten elyaf kullanımını göstermektedir. Tabakalı kompozitlerin dizayn ve optimizasyonu Differential Evolution (DE), Nelder Mead (NM), Random Search (RS) ve Simulated Annealing (SA) algoritmaları yardımıyla yapılmıştır. Önerilen optimum grafit-keten / epoksi kompozit yapı, maksimum doğal frekans ve minimum maliyet açısından grafit-cam / epoksi yapıdan daha iyi sonuçlar vermiştir. Aynı tabakalı yapı tasarımı problemleri için DE, NM ve SA algoritmaları literatürdeki Ant Colony algoritması (ACO), Simulated Annealing (SA) ve Genetic Algoritma (GA) karşısında üstün veya en azından benzer performans göstermiştir.



# CHAPTER 1

## INTRODUCTION

### 1.1 Literature Survey

Laminated composites are fairly used in automotive, marine, aerospace and other engineering applications because of their inherent tailorability. Traditional fiber reinforced composite materials generally have consisted of glass, carbon and /or combination of these. In addition to being strong and rigid, when these materials are mixed, they save up cost and weight. However, in recent years, automobile, aircraft and construction industries focus on eco-friendly materials including cheaper, lightweight and high mechanical properties (Prabhakaran et al., 2014). Flax fiber is one of the natural fibers having high specific strength and low density and they can be used as an alternative to glass fiber in a composite system. A detailed discussion about the usage of flax fiber instead of glass in terms of vibration damping, cost efficiency, fracture toughness and fatigue behavior can be found in (Prabhakaran et al., 2014; Duc et al., 2014; Dittenber and Gangarao, 2012; Zhang et al., 2013; Liang et al., 2012). In the literature, even though mechanical properties of flax fiber are handled by researchers, there are only few studies concerning damping and vibration capabilities.

In recent years, it is possible to obtain appropriate designs including desired physical features of anisotropic materials with the development of stochastic optimization methods. In this regard, the design of some engineering structures sometimes necessitates the maximization or minimization of the objective function for the process. For example, maximizing the natural frequency (Reiss and Ramachandran, 1987; Fukunago et al., 1987; Narita, 2003, 2006; Karakaya and Soykasap, 2011; Lakshmi and Rao, 2015), maximizing critical buckling load factor (Le Riche and Haftka, 1992; Erdal and Sonmez, 2005; Soykasap and Karakaya, 2007; Karakaya and Soykasap, 2009), dimensional stability (Aydin, 2011; Aydin et al., 2015, 2016; Bressan et al., 2004; Le Riche and Gaudin, 1998), minimization of failure index



(Groenwold and Haftka, 2006; Lopez et al., 2009) are used in developing new materials systematically. However, the design and optimization of the engineering structures need to be maximized and / or minimized frequently conflicting more than one objectives, simultaneously. In this situation, multi-objective approach is used and Pareto optimal solutions are gained. There are several examples on the multi objective optimization problems for laminated composites in the literature in terms of cost-weight (Abachizadeh and Tahani, 2007; Hemmatian et al., 2013; Rao and Lakshmi, 2011), frequency-cost (Tahani et al., 2005), strength-mass (Pelletier and Vel, 2006), weight-cost-failure load (Ghasemi and Ehsani, 2007), deflection-weight (Walker et al., 1998), stiffness-thermal expansion coefficient, critical buckling load-critical temperature rise and failure load (Spallino and Rizzo, 2002), weight, buckling and failure load factor (Irisarri et al., 2009). In this approach, it is not possible to obtain the best solution for all objectives, thus only one solution is selected from the set of solutions for practical engineering usage. (Aydin and Artem, 2011).

In dynamical engineering systems, fundamental frequency is an important issue in order to prevent resonance arising from external excitations, therefore many researchers have solved fundamental frequency optimization problems including practical applications of engineering. Reiss and Ramachandran (1987), Bert (1977) and Grenestedt (1989) investigated the maximum fundamental frequency for laminated composite plates based on single objective approach by continuous design variables. Duffy and Adali (1991) solved the same problem for cross ply laminates. Qatu (1991) inquired effects of material type, fiber orientation and edge conditions on the natural frequency and mode shapes for symmetric laminated composite plates by using Ritz method. Narita and Leissa (1992) handled free vibration problem for cantilever and rectangular angle-ply and cross-ply laminated composite plates using Ritz method. Narita (2006) used combined LO-FEM (layerwise optimization and finite element analysis) approach to determine free vibration behavior of symmetric laminated rectangular and square plates with mixed boundary conditions. Topal (2012) tackled the applicability of extended layerwise optimization method (ELOM) to maximize the fundamental frequency of laminated composite plates with various aspect ratios and mixed boundary conditions. The first order shear deformation theory (FSDT) is utilized for the finite element solution of the laminated composites. Khdeir and Reddy (1999) proposed a complete set of linear equations for cross-ply

and angle-ply laminated plates concerning free vibration utilizing second order shear deformation theory and gained analytical solutions with arbitrary boundary conditions for thin and moderately thick plates. Cong et al. (2011) investigated effect of cutout upon natural frequency and mode shape for cross-ply laminated composite plates with different aspect ratios and boundary conditions using first order shear deformation theory.

In addition to mechanical point of view of laminated composite structures, it is also crucial to consider the cost and weight factors in engineering problems. Therefore, fundamental frequency, weight and cost of the structures can be preferred as an objective functions of the design and optimization problems. This attempt can be achieved either by multi objective or single objective approaches. For instance, by single objective approach: Adali and Duffy (1992) viewed minimum cost design of antisymmetric, angle-ply hybrid laminates under fundamental frequency constraint. Adali and Verijenko (2001) deal with fundamental frequency, frequency separation and cost factor for graphite-glass/epoxy symmetric interply hybrid laminates and determined the optimum discrete stacking sequence design. Moreover, it should be noted that interply hybrid laminated construction involves high-stiffness and expensive material in the surface layers and low-stiffness and cheap one in inner layers. This type of construction provides both suitable structural rigidity and low cost simultaneously. Therefore, multi objective optimization approach is usually preferred in the solution of the design problems for interply hybrid laminated composites. The previous studies about multi objective optimization problems in interply hybrid laminated composite exhibit that the designers can reduce cost and weight of laminated composite as well as providing safer design. In this regard, Abachizadeh and Tahani (2009) solved multi objective optimization problem of composite graphite-glass/epoxy symmetric interply hybrid laminates for maximum fundamental frequency and minimum cost. Beluch et al. (2007) determined optimum stacking sequence and the number of inner and outer layers for graphite-glass/epoxy interply hybrid structure in terms of minimum cost and maximum fundamental frequency and frequency separations. Grosset et al. (2001) carried out minimum cost-weight design under frequency constraint. Baier et al. (2008) dealt with combined continuous-discrete optimization problem using geometry and material parameters on the o side of plate. The Pareto set optimal solution is obtained for composite satellite equipment in terms of minimum mass and high resonance

frequency. Design and optimization problems of laminated composites include complicated, highly nonlinear functions, hence stochastic optimization methods such as Genetic Algorithm and Simulated Annealing become appropriate to solve them. Genetic Algorithm is used for stacking sequence optimization of laminated composites for maximum buckling load under contiguity and strain failure constraints (Le Riche and Haftka, 1992), for maximum fundamental frequency of laminated plate with different edge conditions (Apalak et al., 2008), for minimum weight of laminated composites under strength and stiffness constraints (Callahan and Weeks, 1992) and maximizing the twisting displacement of a cantilevered composite plate under contiguity and failure constraints (Soremekun et al., 2001). Simulated Annealing Algorithm is preferred in the solution of natural frequency and buckling optimization problems (Karakaya and Soykasap, 2011), for maximum natural frequency with buckling torque and torsional strength constraints and minimum weight with frequency constraint (Gubran and Gupta, 2002), for minimum weight optimization of laminated composite plates subjecting to different in-plane loadings considering Tsai-Wu and the maximum stress failure criteria (Akbulut and Sonmez, 2008). Apart from GA and SA, Random search method is used for weight minimization satisfying failure criteria (Fang and Springer, 1993) and to determine the effects of uncertain material properties on the buckling behavior of laminated composites (Nguyen, 2017). Differential Evolution method is preferred to find the optimum stacking sequence for symmetric and unsymmetric laminated composite plates with simply supported and clamped boundaries considering maximum natural frequency and constant stiffness (Roque and Martins, 2017), for maximum buckling load factor of laminated composite using integer and continuous design variables (Ho-Huu et al., 2016). By considering the literature on laminated composite design, it is seen that optimum natural frequency maximization studies have a wide range of area based on the stochastic optimization methods. In this regard, the studies on Ant Colony Algorithm including minimum cost (Abachizadeh and Tahani, 2009), Evolutionary Strategy Algorithms involving minimum mass (Baier et al., 2008), multi objective evolutionary algorithm including minimum cost (Beluchi et al., 2007), Modified feasible direction (MFD) method, Golden section method (GS) (Topal and Uzman, 2008) and discrete singular convolution (DSC) method (Civelek, 2008) for different boundary condition, Discrete hybrid PSO algorithm (Rao and Lakshmi, 2011) regarding minimum cost and weight, Differential Evolution method

considering minimum weight as second objective function (Vo-Duy et al., 2017), Globalize Bounded Nelder Mead Method (GBNM) (Ameri et al., 2012) can be found in the literature. Moreover, some researchers compared different stochastic optimization methods such as Genetic Algorithm, Simulated Annealing and Generalized Pattern Search for laminated composite optimization problems (Aydin and Artem, 2011; Hasancebi et al., 2010; Manoharan et al., 1999).

## 1.2 Objectives

In this study, stacking sequence design and optimization of laminated composite plates for maximum fundamental frequency and minimum cost are determined using stochastic optimization methods: Differential Evolution (DE), Nelder Mead (NM), Simulated Annealing (SA) and Random Search (RS). Simply supported symmetric and symmetric- balanced composite plates with constant total thickness (2mm) and different aspect ratios (length to width) are considered. Considered composite plates consist non hybrid (graphite/epoxy, glass/epoxy, flax/epoxy) and hybrid (graphite-glass/epoxy, graphite-flax/epoxy) structures. Fiber orientation angle, the numbers and the thicknesses of the surface and core layers are taken as design variables. The aim of this thesis can be listed as follows;

- To maximize fundamental frequency and minimize cost simultaneously.
- Comparison of the stacking sequence designs of laminated composites for different aspect ratios using stochastic methods DE, NM, SA, RS.
- Comparison of discrete and continuous stacking sequences designs for the same laminated composite structure design and optimization problems.
- Determination of performance of hybrid structures consisting high stiffness in surface layers and low stiffness in core layers in terms of fundamental frequency and cost.
- To research the usage of flax fiber, one of the natural fiber instead of glass fibres as reinforcement in composites for fundamental frequency maximization problems.
- Comparison of performance of the proposed algorithms (DE, NM, SA, RS) with popular algorithms (Ant Colony, Genetic Algorithm, Simulated Annealing) used in literatures.

## CHAPTER 2

### COMPOSITE MATERIALS

#### 2.1 Introduction

In general terms, a composite can be describe as a structural material which comprises two or more components that are compounded at macroscopic level and are not soluble in each other. These components are called the reinforcement phase and the matrix. The reinforcement material can be in the form of particles, sheets, fibers or distinct other geometries. The matrix materials are usually in continuous nature. Epoxy reinforced with carbon fibers and concrete reinforced with steel, etc. are some composite system examples (Kaw, 2006).

The usage of composite materials have continued for many centuries. For example, the ancient Egyptian workers utilized chopped straw in bricks during the construction of pyramids to improve their structural integrity. Eskimos used moss to carry out strength ice homes. The Japanese Samurai warriors utilized multilayered metals in the forging of their swords to supply admirable material properties. In the 20<sup>th</sup> century, civil engineers place construction iron into cement and manufactured a well-known composite material, i.e., reinforced concrete. It can be said that the modern times of composite materials started with the use of fiberglass polymer matrix composites during World War II (Vinson and Sierakowski, 2004).

Fiber-reinforced composite materials have low density, high specific modulus (ratio between the young modulus and the density) and specific strength (ratio between strength and density). In addition to these natural features, these materials include some important design parameters to be able to tailored and provided advantage to against conventional isotropic materials such as ply orientation and stacking sequence. Thus, fiber-reinforced composite materials are fairly utilized instead of metals in aerospace, automotive, marine and other branches of engineering applications.

Figure 2.1 shows the usage of fibers, composites and the other traditional materials in terms of specific strength on annual basis.

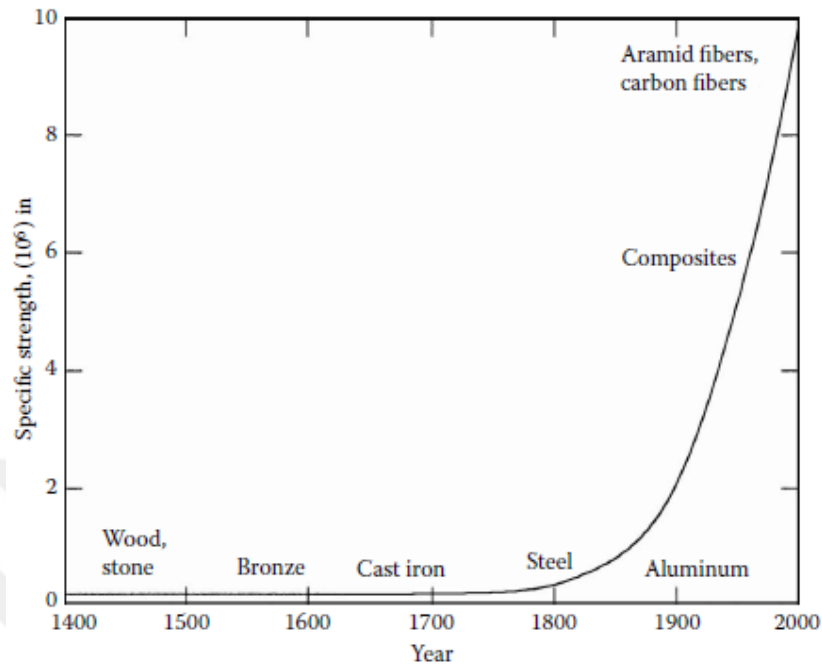

**Figure 2.1** : Specific strength as a function of time of use of materials

(Source: Kaw 2006)

Table 2.1 shows that specific strength and specific modulus properties for commonly utilized composite fibers, unidirectional composites, cross-ply and quasi-isotropic laminated composites and monolithic metals. (Kaw, 2006).

**Table 2.1** : Specific Modulus and Specific Strength Values of Typical Fibers, Composites and Bulk Metals (Source: Kaw 2006)

Materials Units	Specific Gravity	Young's Modulus (GPa)	Ultimate Strength (MPa)	Specific Modulus (GPa-m <sup>3</sup> /kg)	Specific Strength (MPa-m <sup>3</sup> /kg)
System of Units: SI					
Graphite fiber	1.8	230	2067	0.1278	1.148
Aramid fiber	1.4	124	1379	0.08857	0.9850
Glass fiber	2.5	85	1550	0.0340	0.6200
Unidirectional graphite/epoxy	1.6	181	1500	0.1131	0.9377
Unidirectional glass/epoxy	1.8	38.60	1062	0.02144	0.5900
Cross-ply graphite/epoxy	1.6	95.98	373	0.06000	0.2331
Cross-ply glass/epoxy	1.8	23.58	88.25	0.01310	0.0490
Quasi-isotropic graphite/epoxy	1.6	69.64	276.48	0.04353	0.1728
Quasi-isotropic glass/epoxy	1.8	18.96	73.08	0.01053	0.0406
Steel	7.8	206.84	648.10	0.02652	0.08309
Aluminum	2.6	68.95	275.80	0.02652	0.1061

## 2.2 Classification of Composites

Composites can be classified either the geometry of the reinforcement material such as particulate, flake and fibers (Figure 2.2) or the type of matrix such as metal, ceramic, carbon and polymer.

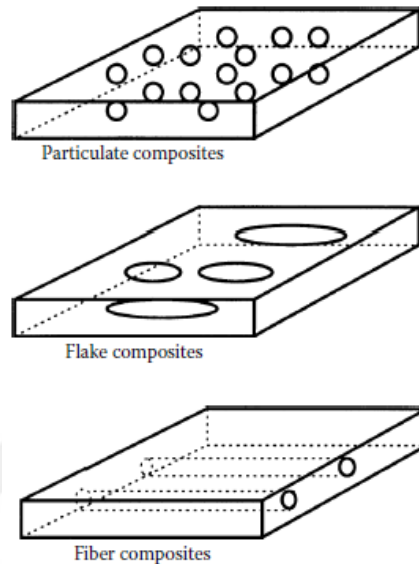

**Figure 2.2 :** Types of composites based on reinforcement shape  
(Source: Kaw 2006)

Particulate composites comprise inserted particles in matrices such as alloys and ceramics. As the particles disperse randomly in matrices, they can be supposed as isotropic. These composites have some advantages such that advanced strength, enhanced operating temperature, and oxidation resistance. The usage of aluminum particles in rubber; silicon carbide particles in aluminum; and gravel, sand, and cement to conduct concrete are common examples of them (Kaw, 2006).

Flake composites comprise of thin, flat reinforcements suspended in matrices. Aluminum, glass, mica and silver can be utilized as flake materials in composites. Main advantages of the usage of flake composites in structure are higher strength and out-of-plane flexural modulus and low cost. On the other hand, these composites have some drawbacks. For instance, flakes cannot be directed easily and only a few number of materials are appropriate for use (Kaw, 2006).

Fiber composites comprise matrices, reinforced fibers and an interface. Fibers consists of either short (discontinuous) type or long (continuous) type fiber having high aspect ratio . Carbon, graphite, boron, kevlar and aramids can be chosen as fibers for composites.

Metals such as titanium, aluminum or magnesium; ceramics such as calcium–alumina silicate and resins such as epoxy, vinyl ester, polyester are instances of matrices. Continuous fiber matrix composite materials contain unidirectional or woven fiber laminas. Laminas are piled up top of each other at diverse angles to make up a multidirectional laminate (Kaw, 2006).

The most widely used advanced composites are polymer matrix composites (PMCs) comprising of a polymer such as epoxy, polyester and urethane, reinforced by thin diameter fibers such as graphite, glass, boron and aramid. These composites are mostly preferred because of their low cost, high strength, and simple manufacturing principles. The main disadvantages of PMCs are low operating temperatures, high coefficients of thermal and moisture expansion and low elastic properties in certain directions.

Graphite and glass fibers in polymer matrix composite are used wide range of engineering applications. Graphite fibers are more often used in high-modulus and high-strength applications such as aircraft components, etc. They have low coefficient of thermal expansion, and high fatigue strength. The disadvantages are high cost, low impact resistance, and high electrical conductivity. Especially, high cost restricts the usage of this material without special applications. To overcome this disadvantage, glass fibers are used together with graphite in hybrid structure. In this way, it can be provided that both suitable structural rigidity and low cost. In addition to low cost, glass fiber has advantages that high strength and chemical resistance, good insulating properties. The disadvantages are low elastic modulus, poor adhesion to polymers, high specific gravity, sensitivity to abrasion (reduces tensile strength) and low fatigue strength. The main types of glass fibers are E-glass (fiberglass) used for electrical and structural applications, S-glass included higher content of silica and keep its strength at high temperatures. Other types of glass fiber are C-glass (Corrosion) preferred in chemical environments, R-glass utilized in structural applications, D-glass (Dielectric) can be used applications entailing low dielectric constants and A-glass (Appearance) utilized to improve surface appearance.

Natural fibres present several economical, technical and ecological advantages compared to synthetic fibres in reinforcing polymer composites because of low density and cost, high specific properties, health advantages, recyclability and eco-friendly profile. Such as flax, hemp and jute, natural fibers have been preferred as alternative reinforcing materials to synthetic fibers, specifically E-glass (Shah et al.,



2012; Wambua et al., 2003; Faruk et al., 2012). Comparison of different properties between natural fibers and E-glass fiber are indicated in Table 2.2.

**Table 2.2 :** Comparison between plant fibers and E-glass (Source: Shah et al., 2013)

	<b>Properties</b>	<b>Plant fibres</b>	<b>E-Glass fibre</b>
<b>Economy</b>	Annual global production (tonnes)	31,000,000	4,000,000
	Distribution for FRPs in EU (tonnes)	Moderate (40,000)	High (600,000)
<b>Technical</b>	Density ( $\text{g cm}^{-3}$ )	Low (~1.35-1.55)	High (2.66)
	Tensile stiffness (GPa)	Moderate (~30-80)	Moderate (73)
	Tensile strength (GPa)	Low (~0.4-1.5)	Moderate (2.0-3.5)
	Tensile failure strain (%)	Low (~1.4-3.2)	Low (2.5)
	Specific tensile stiffness ( $\text{GPa/g cm}^{-3}$ )	Moderate (~20-60)	Low (27)
	Specific tensile strength ( $\text{GPa/g cm}^{-3}$ )	Moderate (~0.3-1.1)	Moderate (0.7-1.3)
	Abrasive to machines	No	Yes
<b>Ecological</b>	Energy consumption (MJ/kg of fibre)	Low (4-15)	Moderate (30-50)
	Renewable source	Yes	No
	Recyclable	Yes	Partly
	Biodegradable	Yes	No
	Toxic (upon inhalation)	No	Yes

It is thought that natural fibres cause less health problems for the people working composites production and these materials do not lead to skin irritations and lung cancer. This is an important issue because the discussion about whether or not small glass fibres can lead to lung cancer, has still not finished. The large amount of dust that occurs in the preliminary phase of the flax fiber insulation process can be relatively controlled in the modern flax fiber processing industry (Bos, 2004).

In addition to being healthy, natural fibers are lower cost and weight than synthetic fibers. For the aerospace, military and automotive industry, weight and cost reduction without sacrificing from mechanical properties is an always important issue. The usage of natural fibers as fillers meets this need. The cost of some natural fiber, glass and graphite fiber are shown in Figure 2.3.

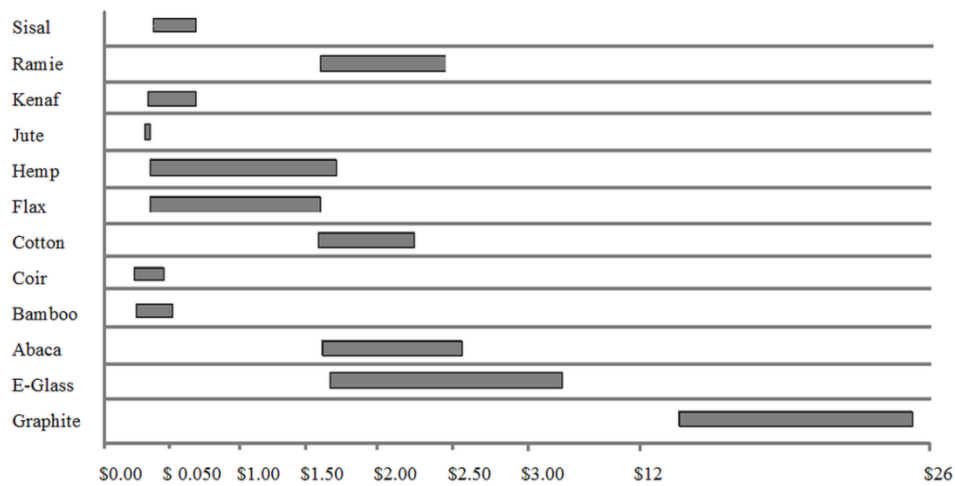

**Figure 2.3 :** Cost per weight comparison between glass, graphite and natural fibres (Dittenber et al., 2012)

There are several polymers used in advanced polymer composites classified thermoset (epoxies, polyesters, phenolics, and polyamide) and thermoplastic (polyethylene, polystyrene, polyether-ether-ketone (PEEK) and polyphenylene sulfide (PPS)). Thermoset polymers connected strong covalent bonds are insoluble and infusible after cure; thermoplastics include weak van der Waals bonds and thus they can be formed at high pressure and high temperatures. The diversities between thermosets and thermoplastics are denoted in Table 2.3 (Kaw, 2006).

**Table 2.3 :** Differences between thermosets and thermoplastics

(Source: Kaw, 2006)

<b>Thermoplastics</b>	<b>Thermosets</b>
Soften on heating and pressure, and thus easy to repair	Decompose on heating
High strains to failure	Low strains to failure
Indefinite shelf life	Definite shelf life
Can be reprocessed	Cannot be reprocessed
Not tacky and easy to handle	Tacky
Short cure cycles	Long cure cycles
Higher fabrication temperature and viscosities have made it difficult to process	Lower fabrication temperature
Excellent solvent resistance	Fair solvent resistance

Epoxy resins are the most commonly used thermoset PMC, nevertheless they are more expensive than other polymer matrices. Epoxy matrices have some advantages such as high strength, low viscosity and low flow rates that permit good wetting of fibers and prevent misalignment of fibers during processing, low evaporation during cure, low shrinkage, which decrease the tendency of obtaining large shear stresses of

the bond between epoxy and its reinforcement and so they are usable for a wide range of engineering applications.

Metal matrix composites (MMCs) comprise of metals or alloys (aluminum, magnesium, titanium, copper) reinforced with carbon (graphite), boron or ceramic fibers. The materials are commonly used to provide advantages over metals such as steel and aluminum. The main advantages of these composites can be listed as higher specific modulus and strength by low density metals such as aluminum and titanium, lower coefficients of thermal expansion, such as graphite.

Ceramic matrix composites (CMCs) include ceramic matrices (alumina calcium, silicon carbide, aluminum oxide, glass-ceramic, silicon nitride) reinforced with ceramic fibers. The main advantages of CMCs are high strength, hardness, high service temperature limits for ceramics, chemical inertness and low density. Nevertheless ceramic matrix composites have low fracture toughness.

Carbon-carbon composites (C/C) contain carbon fibers reinforcement in the carbon or graphite matrix. This type of composites have excellent properties of high strength at high temperature, low thermal expansion and density. Disadvantages of C/C composites are their high cost, low shear strength, and sensitivity to oxidations at high temperatures. Typical properties of conventional matrix materials are given as comparative with each other in Table 2.4 and Table 2.5, each type of matrix and fiber has their advantages and drawbacks.

**Table 2.4 :** Comparison of Conventional Matrix Materials

(Source: Daniel and Ishai, 2005)

Property	Metals	Ceramics		Polymers
		Bulk	Fibers	
Tensile strength	+	-	++	v
Stiffness	++	V	++	-
Fracture toughness	+	-	v	+
Impact strength	+	-	v	+
Fatigue endurance	+	V	+	+
Creep	v	V	++	-
Hardness	+	+	+	-
Density	-	+	+	++
Dimensional stability	+	v	+	-
Thermal stability	v	+	++	-
Hygroscopic sensitivity	++	v	+	v
Weatherability	v	v	v	+
Erosion resistance	+	+	+	-
Corrosion Resistance	-	v	v	+

++, superior; +, good; -, poor; v, variable.

**Table 2.5 :** Advantages and disadvantages of reinforcing fibers

(Source: Daniel and Ishai, 2005)

Fiber	Advantages	Disadvantages
E-glass, S-glass	High strength Low cost	Low stiffness Short fatigue life High temperature sensitivity
Aramid (Kevlar)	High tensile strength Low density	Low compressive strength High moisture absorption
Boron	High stiffness High compressive strength	High cost
Carbon (AS4, T300, C6000)	High strength High stiffness	Moderately high cost
Graphite (GY-70, pitch)	Very high stiffness	Low strength High cost
Ceramic ( silicon carbide, alumina)	High stiffness High use temperature	Low strength High cost

### 2.3 Applications of Composite Materials

Fiber-reinforced polymer composites are utilized in various engineering fields since they have better combination of strength and modulus than traditional monolithic metal materials. The application fields of composite materials are aircraft, space, automotive, boats and marine, sporting goods, medical industry and military. Figure 2.4 indicates the relative market share of EU for synthetic and natural fiber composites and it is seen that the most commonly used fiber in composite industry is glass. Composite materials such as carbon, aramid are only used in special applications due to their high prices. For instance, these composites are frequently utilized in the field of military and commercial aircrafts as these materials can provide both lightweight and strength.

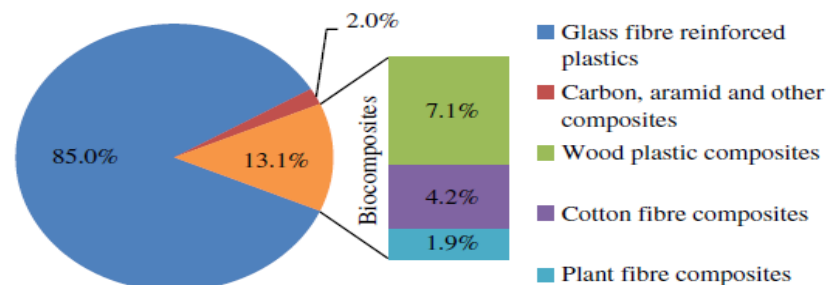

**Figure 2.4 :** PFRPs accounted for 1.9% of the 2.4 million tonne EU FRP market in 2010

(Source: Carus, 2011)

The more lightweight aircraft is the less burn fuel, thus weight minimization is important for military and commercial aircrafts. Figure 2.5 illustrates usage of composite materials in various components of the Boeing 787 aircraft. Carbon fibers are familiarized (acquaint) to industry in the 1970s and carbon- epoxy has been used as the primary material in many wing, empennage and fuselage components. The structural integrity and durability of constituent have enhanced confidence in their performance and developments of other structural aircraft constituents, thus increasing amount of composite materials are utilized in military aircrafts. For instance, the F-22 fighter aircraft have also 25% by weight of carbon fiber reinforced polymers; the other materials are titanium (39%) and aluminum (16%). The stealth aircrafts are almost all made of carbon fiber-reinforced polymers on account of design features that contain special coatings, decrease radar reflection and heat radiation. Moreover, many fiber-reinforced polymers are used in military and commercial helicopters for conducting baggage doors, fairings, vertical fins, tail rotor spars and so on (Mallick, 2007).

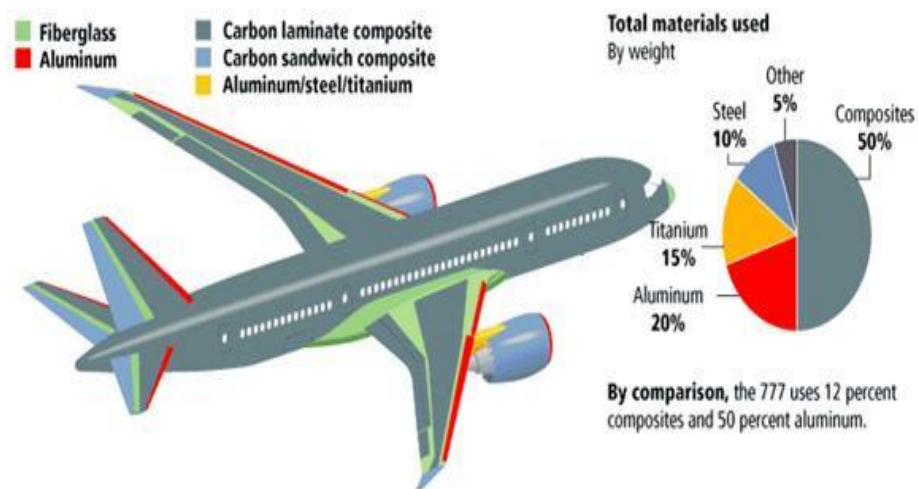

**Figure 2.5 :** Use of fiber-reinforced polymer composites in Boeing 787

(Source: Bintang, 2011)

Another important application for composite materials is an automotive industry. Body, chassis and engine constituent are three major constituent in automotive industry. Body constituent such as the hood or door panels necessitate high stiffness and damage tolerance (dent resistance), thus the composite material used for these constitutes is E-glass fiber-reinforced sheet molding compound (SMC) composites. E-glass fiber is utilized instead of carbon fiber due to its considerably

lower cost. For the chassis constituent, the first main structural application of fiber-reinforced composites is rear leaf spring. The usage of unileaf E-glass fiber-reinforced epoxy springs instead of multileaf steel springs provide approximately 80% weight reduction. Other chassis constituent, such as drive shafts and wheels have been successfully tested, but they have been manufactured in limited quantities. The application of fiber reinforced composites in engine constituent has not been as successful as the other constituent (Mallick, 2007).

Nowadays, the usage of natural fibres instead of glass fibres as reinforcement in composites for engineering applications has obtained popularity because of an increasing environmental anxiety and necessity for developing sustainable materials. Approximately 315,000 tonnes of natural fibres were used as reinforcement in composites in the European Union (EU) in 2010, which are constituted for 13% of the total reinforcement materials (glass, carbon and natural fibres) in fibre reinforced composites (Yan et al., 2014). By commercial application, over 95% of PFRPs produced in the EU are used for non-structural automotive components. Table 2.6 shows the usage of natural fibers in automotive part.

**Table 2.6 :** Application of natural fibres in automotive parts (Source : Bos, 2004).

Manufacturer	Model
	<i>Application (dependent on model)</i>
Audi	A3, A4, A4 Avant, A6, A8, Roadster, Coupe <i>Seat back, side and back door panel, boot lining, hat rack, spare tire lining</i>
BMW	3, 5 and 7 Series and others <i>Door panels, headliner panel, boot lining, seat back</i>
Daimler/ Chrysler	<i>A-Series, C-Series, E-Series, S-Series</i> <i>Door panels, windshields/dashboard, business table, pillar cover panel</i>
Fiat	Punto, Brava, Marea, Alfa Romeo 146, 156
Ford	Mondeo CD 162, Focus <i>Door panels, B-pillar, boot liner</i>
Opel	Astra, Vectra, Zafira <i>Headliner panel, door panels, pillar cover panel, instrument panel</i>
Peugeot	New model 406
Renault	Clio
Rover	Rover 2000 and others <i>Insulation, rear storage shelf/panel</i>
Saab	<i>Door panels</i>
SEAT	<i>Door panels, seat back</i>
Volkswagen	Golf A4, Passat Variant, Bora <i>Door panel, seat back, boot lid finish panel, boot liner</i>
Volvo	C70, V70

Actually, the automotive industry utilizes wood fibres as fillers. Wood reinforced fibres are quite short and this materials provide stiffer composites, however, they do not conduct them stronger. Thus, later, other longer reinforced natural cellulose fibres like flax, jute, hemp and sisal were developed for otomativ application. Without automotive applications, natural fibers are used for interior components such as instrumental panels and door, they are used for applications in infrastructure and construction such as bridges, roof panels, beams,; sports equipments such as boat hulls, canoes, tennis rackets, bicycle frames; consumer and furniture goods such as packaging, chairs, cases, urns, tables, helmets, ironing boards.



## CHAPTER 3

### MECHANICS OF COMPOSITE MATERIALS

The mechanics of materials takes into consideration the concepts of stresses, strains, and deformations in engineering structures subjected to mechanical and environmental effects for instance moisture, temperature and radiation. A common consideration for mechanics of traditional engineering materials such as stainless steel, metal, copper, bronze and lead is that, these materials are homogeneous and isotropic. Their properties are independent of location and orientation. On the contrary, fiber reinforced composite materials are inhomogeneous and non-isotropic (orthotropic). As a result of this, the mechanical analysis of fiber-reinforced composite materials are much more sophisticated than that of traditional materials (Mallick, 2007).

Fiber reinforced composite materials can be analyzed in two distinct levels: (i) macromechanical analysis and (ii) micromechanical analysis. These terms can be explained as follows.

**Micromechanics:** Mechanical analysis of the interactions of the components are microscopic level. This study is usually conducted by means of a mathematical model defining the response of each component material.

**Macromechanics:** In this analysis, material is assumed homogeneous. Mechanical analysis of the interactions of the components and their effects of interactions on the overall response quantities of the laminate are investigated in macroscopic level.

At the laminate level, the macromechanical analysis is utilized in the form of lamination theory to analyze whole behaviour as a function of lamina properties and stacking sequence (Daniel and Ishai, 2005).

#### 3.1 Classical Lamination Theory

Classical laminated plate theory is applied to define mechanical behaviour of laminated composites. This theory is only used in the following assumptions



1. Each lamina is homogeneous and orthotropic.
2. Each lamina is elastic and perfectly bounded each other.
3. The laminated composite is thin and the thickness of composite plate are much lesser than its edge dimensions.
4. The loadings are only implemented in the laminate's plane and the laminated composite (except for their edges) is subjected to plane stress ( $\sigma_z = \tau_{xz} = \tau_{yz} = 0$ ).
5. Displacements are small contrast with the thickness of the laminate and they are continuous throughout the laminate.
6. In plane displacements in the  $x$  and  $y$  directions are linear functions of  $z$ .
7. Transverse shear strains ( $\gamma_{xz}$  and  $\gamma_{yz}$ ) are ignorable because a line straight and perpendicular to the middle surface preserves state throughout deformation.

Considered thin laminated composite plate in this thesis is shown in Figure 3.1. Global coordinates of the layered material are defined  $x$ ,  $y$  and  $z$ . A layer-wise principal material coordinate system is indicated by 1, 2, 3 and fiber direction is oriented at angle  $\theta$ . Representation of laminate convention for the  $n$ -layered structure with total thickness  $h$  is given in Figure 3.2.

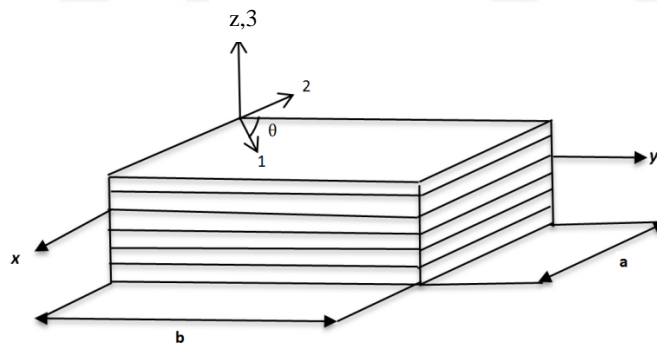

**Figure 3.1 :** A thin fiber-reinforced laminated composite

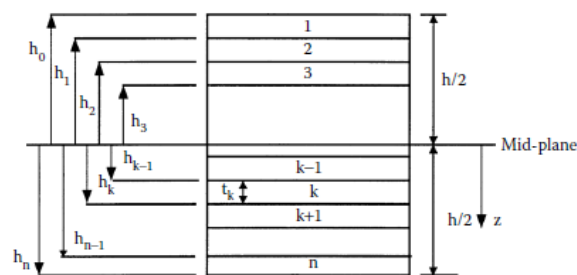

**Figure 3.2 :** Coordinate locations of plies in a laminate (Source: Kaw, 2006)

The strains at any point in the laminate to the reference plane can be written as

$$\begin{bmatrix} \varepsilon_x \\ \varepsilon_y \\ \gamma_s \end{bmatrix} = \begin{bmatrix} \varepsilon_x^o \\ \varepsilon_y^o \\ \gamma_s^o \end{bmatrix} + z \begin{bmatrix} \kappa_x \\ \kappa_y \\ \kappa_s \end{bmatrix} \quad (3.1)$$

The stress-strain relationship for the  $k$ -th layer of a laminated composite plate considering the classical lamination theory can be written in the following form

$$\begin{bmatrix} \sigma_x \\ \sigma_y \\ \sigma_{xy} \end{bmatrix}_k = \begin{bmatrix} \bar{Q}_{11} & \bar{Q}_{12} & \bar{Q}_{16} \\ \bar{Q}_{12} & \bar{Q}_{22} & \bar{Q}_{26} \\ \bar{Q}_{16} & \bar{Q}_{26} & \bar{Q}_{66} \end{bmatrix}_k \left( \begin{bmatrix} \varepsilon_x^o \\ \varepsilon_y^o \\ \varepsilon_{xy}^o \end{bmatrix} + z \begin{bmatrix} \kappa_x \\ \kappa_y \\ \kappa_{xy} \end{bmatrix} \right) \quad (3.2)$$

where  $[\bar{Q}_{ij}]_k$  are the in plane elements of the transformed reduced stiffness matrix under plane stress condition,  $[\varepsilon^o]$  is the mid-plane strains,  $[\kappa]$  is curvatures, respectively.

The elements of transformed reduced stiffness matrix  $[\bar{Q}_{ij}]$  can be expressed as in the following form

$$\bar{Q}_{11} = Q_{11}c^4 + Q_{22}s^4 + 2(Q_{12} + 2Q_{66})s^2c^2 \quad (3.3)$$

$$\bar{Q}_{12} = (Q_{11} + Q_{22} - 4Q_{66})s^2c^2 + Q_{12}(c^4 + s^4) \quad (3.4)$$

$$\bar{Q}_{22} = Q_{11}s^4 + Q_{22}c^4 + 2(Q_{12} + 2Q_{66})s^2c^2 \quad (3.5)$$

$$\bar{Q}_{16} = (Q_{11} - Q_{12} - 2Q_{66})sc^3 - (Q_{22} - Q_{12} - 2Q_{66})s^3c \quad (3.6)$$

$$\bar{Q}_{26} = (Q_{11} - Q_{12} - 2Q_{66})cs^3 - (Q_{22} - Q_{12} - 2Q_{66})sc^3 \quad (3.7)$$

$$\bar{Q}_{66} = (Q_{11} + Q_{22} - 2Q_{12} - 2Q_{66})s^2c^2 + Q_{66}(c^4 + s^4) \quad (3.8)$$

where stiffness matrix quantities  $[Q_{ij}]$  are

$$Q_{11} = \frac{E_1}{1 - \nu_{21}\nu_{12}} \quad (3.9)$$

$$Q_{12} = \frac{\nu_{12}E_2}{1 - \nu_{21}\nu_{12}} \quad (3.10)$$

$$Q_{22} = \frac{E_2}{1 - \nu_{21}\nu_{12}} \quad (3.11)$$

$$Q_{66} = G_{12} \quad (3.12)$$

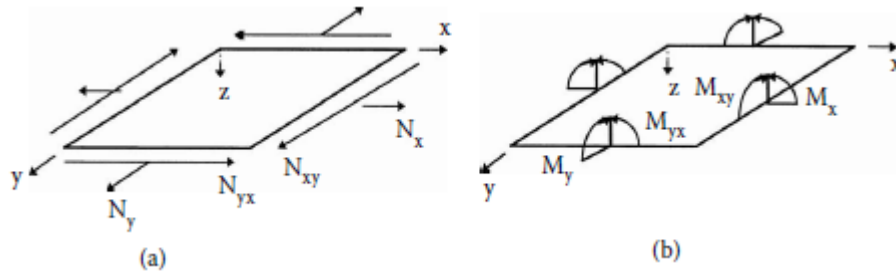

**Figure 3.3 :** Resultant forces and moments on a laminate (Source: Kaw, 2006)

Applied normal force resultants  $N_x, N_y$ , shear force resultant  $N_{xy}$  (per unit width) and moment resultants  $M_x, M_y$  and  $M_{xy}$  on a laminate (Fig. 3.3) have the following relations:

$$\begin{bmatrix} N_x \\ N_y \\ N_{xy} \end{bmatrix} = \begin{bmatrix} A_{11} & A_{12} & A_{16} \\ A_{12} & A_{22} & A_{26} \\ A_{16} & A_{26} & A_{66} \end{bmatrix} \begin{bmatrix} \varepsilon_x^0 \\ \varepsilon_y^0 \\ \gamma_{xy}^0 \end{bmatrix} + \begin{bmatrix} B_{11} & B_{12} & B_{16} \\ B_{12} & B_{22} & B_{26} \\ B_{16} & B_{26} & B_{66} \end{bmatrix} \begin{bmatrix} \kappa_x \\ \kappa_y \\ \kappa_{xy} \end{bmatrix} \quad (3.13)$$

$$\begin{bmatrix} M_x \\ M_y \\ M_{xy} \end{bmatrix} = \begin{bmatrix} B_{11} & B_{12} & B_{16} \\ B_{12} & B_{22} & B_{26} \\ B_{16} & B_{26} & B_{66} \end{bmatrix} \begin{bmatrix} \varepsilon_x^0 \\ \varepsilon_y^0 \\ \gamma_{xy}^0 \end{bmatrix} + \begin{bmatrix} D_{11} & D_{12} & D_{16} \\ D_{12} & D_{22} & D_{26} \\ D_{16} & D_{26} & D_{66} \end{bmatrix} \begin{bmatrix} \kappa_x \\ \kappa_y \\ \kappa_{xy} \end{bmatrix} \quad (3.14)$$

The matrices  $[A]$ ,  $[B]$  and  $[D]$  specified in Equations 3.13 and 3.14 can be defined as

$$A_{ij} = \sum_{k=1}^n [(\bar{Q}_{ij})]_k (h_k - h_{k-1}), \quad i, j = 1, 2, 6 \quad (3.15)$$

$$B_{ij} = \frac{1}{2} \sum_{k=1}^n [(\bar{Q}_{ij})]_k (h_k^2 - h_{k-1}^2), \quad i, j = 1, 2, 6 \quad (3.16)$$

$$D_{ij} = \frac{1}{3} \sum_{k=1}^n [(\bar{Q}_{ij})]_k (h_k^3 - h_{k-1}^3), \quad i, j = 1, 2, 6 \quad (3.17)$$

The  $[A]$  matrix is extensional stiffness regarding in-plane forces to the in-plane strains,  $[B]$  matrix is coupling stiffness regarding forces and mid-plane strains, moments and mid-plane curvatures and  $[D]$  matrix is bending stiffness regarding moments and curvatures. (Kaw, 2006).

Now, stresses and strain expressions based on classical lamination theory can be expressed by local coordinate system (1, 2). The relation between the local and global stresses in an angled lamina can be written as in the following form:

$$\begin{bmatrix} \sigma_1 \\ \sigma_2 \\ \sigma_{12} \end{bmatrix} = [T] \begin{bmatrix} \sigma_x \\ \sigma_y \\ \sigma_{xy} \end{bmatrix} \quad (3.18)$$

Similarly, the local and global strains are also related as follows

$$\begin{bmatrix} \varepsilon_1 \\ \varepsilon_2 \\ \varepsilon_{12} \end{bmatrix} = [R][T][R]^{-1} \begin{bmatrix} \varepsilon_x \\ \varepsilon_y \\ \varepsilon_{xy} \end{bmatrix} \quad (3.19)$$

where

$$[R] = \begin{bmatrix} 1 & 0 & 0 \\ 0 & 1 & 0 \\ 0 & 0 & 2 \end{bmatrix} \quad (3.20)$$

and  $[T]$  transform matrix,

$$[T] = \begin{bmatrix} c^2 & s^2 & 2sc \\ s^2 & c^2 & -2sc \\ -sc & sc & c^2 - s^2 \end{bmatrix} \quad c = \cos \theta, \quad s = \sin \theta \quad (3.21)$$

### 3.2 Vibration Theory of Laminated Composite Plates

All elastic bodies begin to oscillate about their equilibrium position under the influence of an external stimulus and continue to oscillate when this stimulus is lifted. This oscillation is called free vibration motion. The total number of oscillations per minute is called natural frequency. This number of frequencies is endless for plates that are a continuous medium. The smallest of these frequencies is called the fundamental frequency. In the case of a external vibration force that is equal to any of these frequency values, the amplitude of the distance of the plate from its equilibrium position increases and goes to infinity. This is called as resonance. Therefore, knowing the frequency values in terms of design is very important in terms of enabling the engineering structure to operate without any damage. (Meirovitch, 1986). A vibration analysis usually includes four steps. First, the structure or system of interest is defined, its boundary conditions are predicted and its interfaces with other systems are plotted. Second, the natural frequencies and mode shapes of the structure are designated by analysis or direct experimental measurement. Third, the time dependent loads on the structure are predicted. Fourth, these loads are applied to an analytical model of the structure to specify its response. The major steps in the vibration analysis are the identification of the structure and the determination of its natural frequencies and mode shapes (Blevins, 1979). In this regard, simply supported laminated plate is considered and the governing equation of the free vibration process based on the classical laminated plate theory for the described symmetric laminate is given as follow (Reddy, 2004):

$$D_{11} \frac{\partial^4 w}{\partial x^4} + 4D_{16} \frac{\partial^4 w}{\partial x^3 \partial y} + 2(D_{12} + 2D_{66}) \frac{\partial^4 w}{\partial x^2 \partial y^2} + 4D_{26} \frac{\partial^4 w}{\partial x \partial y^3} + D_{22} \frac{\partial^4 w}{\partial y^4} = \rho h \frac{\partial^2 w}{\partial t^2} \quad (3.22)$$

where  $D_{11}, D_{12}, D_{16}, D_{22}, D_{26}, D_{66}$  are the terms of bending stiffnesses,  $w$  is the deflection in the  $z$  direction,  $h$  is the total thickness of the laminate,  $t$  is time and  $\rho$  is the mass density as

$$\rho = h^{-1} \int_{-h/2}^{h/2} \rho^{(k)} dz = \frac{1}{N} \sum_{k=1}^N \rho^{(k)} \quad (3.23)$$

where  $N$  is the total number of plies,  $k$  is the ply number.

The boundary conditions for the simply supported plate are given as

$$\begin{aligned} w(x,0) = 0, \quad w(x,b) = 0, \quad w(0,y) = 0, \quad w(a,y) = 0 \\ M_{xx}(0,y) = 0, \quad M_{xx}(a,y) = 0, \quad M_{yy}(x,0) = 0, \quad M_{yy}(x,b) = 0 \end{aligned} \quad (3.24)$$

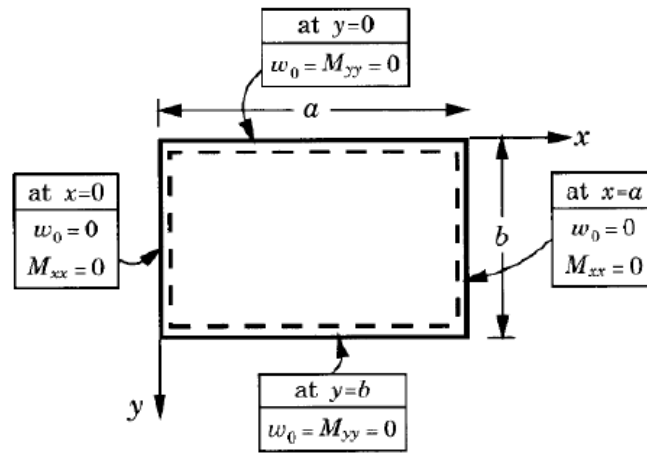

**Figure 3.4 :** Geometry, coordinate system, and simply supported boundary conditions for a rectangular plate (Source: Reddy, 2004)

If the stacking sequence of laminated composite comprise only 0 and 90 degree, this laminate is called special orthotropic. For symmetric special orthotropic laminate,  $A_{16}=A_{26}=B=D_{16}=D_{26} = 0$ , thus, no coupling occurs between the normal-shear forces, bending - twisting moments and force-moment terms. Nemeth (1986) has given the detail about bending-twisting interaction in composite laminates for buckling problems. In case laminated composite is not specially orthotropic, the effect of bending - twisting terms  $D_{16}$  and  $D_{26}$  will be neglected if the non-dimensional parameters have the conditions:

$$\gamma \leq 0.2, \quad \delta \leq 0.2 \quad (3.25)$$

where

$$\gamma = D_{16}(D_{11}^3 D_{22})^{-1/4}$$

$$\delta = D_{26}(D_{11} D_{22}^3)^{-1/4}$$

Because of the similarity between buckling and free vibration analysis, the same constraints are used to reduce complexity of the problem.

The deflection  $w$  for the natural vibration mode  $(m, n)$  is obtained by solving the governing equation (Eq.3.22) with the boundary conditions (Eq.3.24) as :

$$w(x, y, t) = \sum_{m=1}^{\infty} \sum_{n=1}^{\infty} A_{mn} \sin \frac{m\pi x}{a} \sin \frac{n\pi y}{b} e^{i\omega_{mn}t} \quad (3.26)$$

where  $\omega_{mn}$  is the natural frequency of the vibrating mode  $(m, n)$  obtained by solving an eigenvalue problem as

$$\omega_{mn}^2 = \frac{\pi^4}{\rho h} \left[ D_{11} \left( \frac{m}{a} \right)^4 + 2(D_{12} + 2D_{66}) \left( \frac{m}{a} \right)^2 \left( \frac{n}{b} \right)^2 + D_{22} \left( \frac{n}{b} \right)^4 \right] \quad (3.27)$$

Here, different values of  $m$  and  $n$  give different mode shapes of the laminated plate.

Clearly, fundamental frequency can be obtained with the condition  $m=n=1$ .

## CHAPTER 4

### OPTIMIZATION

Optimization can be identified as mathematical process used forming the best design or favorable designs by minimizing or maximizing defined single or multi objectives that fulfill all the constraints. Optimization is frequently used in engineering problems such as weight, cost, vibration, buckling and failure. In such problems, single and multi objective optimization approaches are utilized to obtain desired design of structure. In single objective optimization approach, design and optimization problem comprise of a single objective function, constraints and bounds. Nevertheless, the design and optimization of the engineering structures need to be maximized and / or minimized often conflicting more than one objectives, simultaneously. (Aydin and Artem, 2011). In this situation, multi-objective approach is used and Pareto optimal solutions are gained. In this approach, it is not possible to obtain the best solution for all objectives, thus only one solution is selected from the set of solutions for practical engineering usage (Pelletier and Vel, 2006).

As design and optimization problems of laminated composites include complicated, highly nonlinear functions, they are unsolvable by the traditional optimization methods. In these situation, the usage of stochastic optimization methods such as Differential Evolution (DE), Random Search (RS), Nelder Mead (NM), Simulated Annealing (SA) and Genetic Algorithms (GA) are appropriate.

MATHEMATICA is one of the crucial commercial program that can be used to solve the design and optimization problems for composites. The program includes stochastic methos Differential Evolution (DE), Nelder Mead (NM), Random Search (RS) and Simulated Annealing (SA) for solving optimization problems. All of these methods are used in the design and optimization of composite structures by many researchers.



## 4.1 Single objective optimization

Single objective optimization approach comprises objective function, design variables, constraints and bounds of constraints. In this study, the problems solved using single-objective optimization approach are expressed as follows

$$\begin{aligned}
 &\text{minimize} && f(\theta_1, \theta_2, \dots, \theta_n) \\
 &\text{such that} && h_i(\theta_1, \theta_2, \dots, \theta_n) \geq 0 && i = 1, 2, \dots, r \\
 &&& g_j(\theta_1, \theta_2, \dots, \theta_n) = 0 && j = 1, 2, \dots, m \\
 &&& \theta^L \leq \theta_1, \theta_2, \dots, \theta_n \leq \theta^U
 \end{aligned}$$

where  $f$  is objective function,  $\theta_1, \theta_2, \dots, \theta_n$  are the design variables and  $h, g$  are the constraints of the problem. Here,  $\theta^L$  and  $\theta^U$  show lower and upper bounds. In design and optimization of composite structure problems; stiffness, mass, strength, displacements, thickness, vibration frequencies, buckling loads, residual stresses, cost and weight are utilized as objective functions (Gurdal et al., 1999). In this thesis, fundamental frequency is taken as objective function of the single-objective optimization problems.

## 4.2 Multi objective optimization

A multi-objective optimization problem can be expressed as follows:

$$\begin{aligned}
 &\text{minimize} && f_1(\theta_1, \theta_2, \dots, \theta_n), f_2(\theta_1, \theta_2, \dots, \theta_n), \dots, f_t(\theta_1, \theta_2, \dots, \theta_n) \\
 &\text{such that} && h_i(\theta_1, \theta_2, \dots, \theta_n) \geq 0 && i = 1, 2, \dots, r \\
 &&& g_j(\theta_1, \theta_2, \dots, \theta_n) = 0 && j = 1, 2, \dots, m \\
 &&& \theta^L \leq \theta_1, \theta_2, \dots, \theta_n \leq \theta^U
 \end{aligned}$$

where  $f_1, f_2, \dots, f_n$  denote the objective functions to be minimized simultaneously (Rao, 2009). On the contrary to the traditional multi objective optimization approach, the usage of penalty function formulation may be appropriate because of its advantage of turning constrained optimization problems into the unconstrained ones

and thanks to this, it can be applied to the problem by any of the unconstrained methods. In this thesis, penalty approach based on multi objective optimization is considered to maximize the fundamental frequency and minimize the cost, simultaneously.

### **4.3 Stochastic Optimization Algorithms**

Optimization methods can be categorized as traditional and non-traditional. Traditional methods, such as Lagrange Multipliers and Constrained Variation are analytical and find the optimum solution of only continuous and differentiable functions. Because composite design problems usually have discrete search spaces, the traditional optimization methods can not be utilized. In these cases, the usage of stochastic optimization methods such as Simulated Annealing (SA), Genetic Algorithms (GA), Differential Evolution (DE) and Nelder-Mead (NM) are appropriate. A detailed discussion of different optimization methods is expressed in Rao (2009) for general application of engineering and in Gurdal et al. (1999) for composite design problems. In this thesis, DE, NM, RS and SA methods are used for defined optimization problems of laminated composites and steps of the algorithms are briefly explained in the following subsections. Related parameters of the algorithms are listed in Tables 4.1 used in adjusting the options correctly.

#### **4.3.1 Differential Evolution Algorithm**

Differential Evolution (DE) is a stochastic optimization method which permits alternative solutions for some of the complex composite design and optimization problems such as increasing frequency and frequency separation and obtaining lightweight design. Differential Evolution algorithm includes the following main stages: initialization, mutation, crossover and selection as shown in Figure 4.1. The optimum results of the algorithm change with the parameters: scaling factor, crossover and population size. Detail description of the DE can be found in Storn and Price (1997). DE always considers a population of solutions instead of a single solution at each iteration and is also computationally expensive. It is relatively robust and efficient in finding global optimum of the objective function. However, it is not guaranteed to find the global optima.

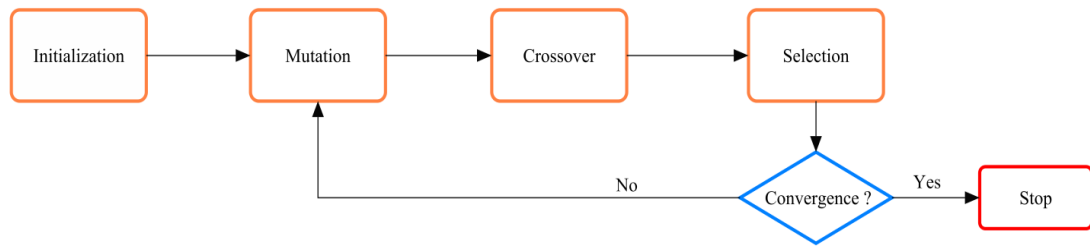

**Figure 4.1** : Flowchart of the DE algorithm. (Adapted from Vo-Duy et al., 2017)

The first step of DE optimization process is Initialization. There are several approaches to populate the initial generation. Random generation is widely used approach for solution. In this step, the algorithm maintains a population of  $r$  points,  $\{x_1, x_2, \dots, x_k, \dots, x_r\}$ , where typically  $r \gg m$ , with  $m$  being the number of variables. In second step, Mutation, a genetic operator that maintains the genetic variety from one generation of a population to the next generation. In mutation process, the solution can different from the previous solution and thus better solution can be gained. In third step, Crossover is used to obtain a richer population. Genetic diversity is encouraged by the interchange of genetic material between chromosomes and then, the gene strings of the related chromosomes are split at the same point in the parents and two parents create a child. Finally, the last step selection is applied and the new individual is added to the new population (Gurdal et al., 1999; Sivanandam and Deepa, 2008; Roque and Martins, 2015).

### 4.3.2 Nelder Mead Algorithm

The Nelder–Mead (simplex search) algorithm is a traditional local search method designed by Nelder and Mead (1965) firstly for unconstrained optimization problem. Although Nelder–Mead is not a global optimization algorithm, it is inclined to work fairly well for problems which do not have many local minima in practical usage. The adjustment of the algorithm options is controlled by four basic procedures: reflection, expansion, contraction and shrinkage. One of the characteristic properties of the algorithm is that NM often gives considerable improvements in the first few iterations and rapidly generates quite adequate results. Moreover, the method usually needs only one or two function evaluations per iteration, apart from shrink transformations, which are notably rare in practice. This is very important in applications that each function evaluation is very expensive or time-consuming. Furthermore, the simplex can vary its orientation, size and shape to adapt itself to the

local contour of the objective function, hence NM has high flexibility in exploring difficult domains (Fan et al., 2006). The main steps of the algorithm are given in Figure 4.2.

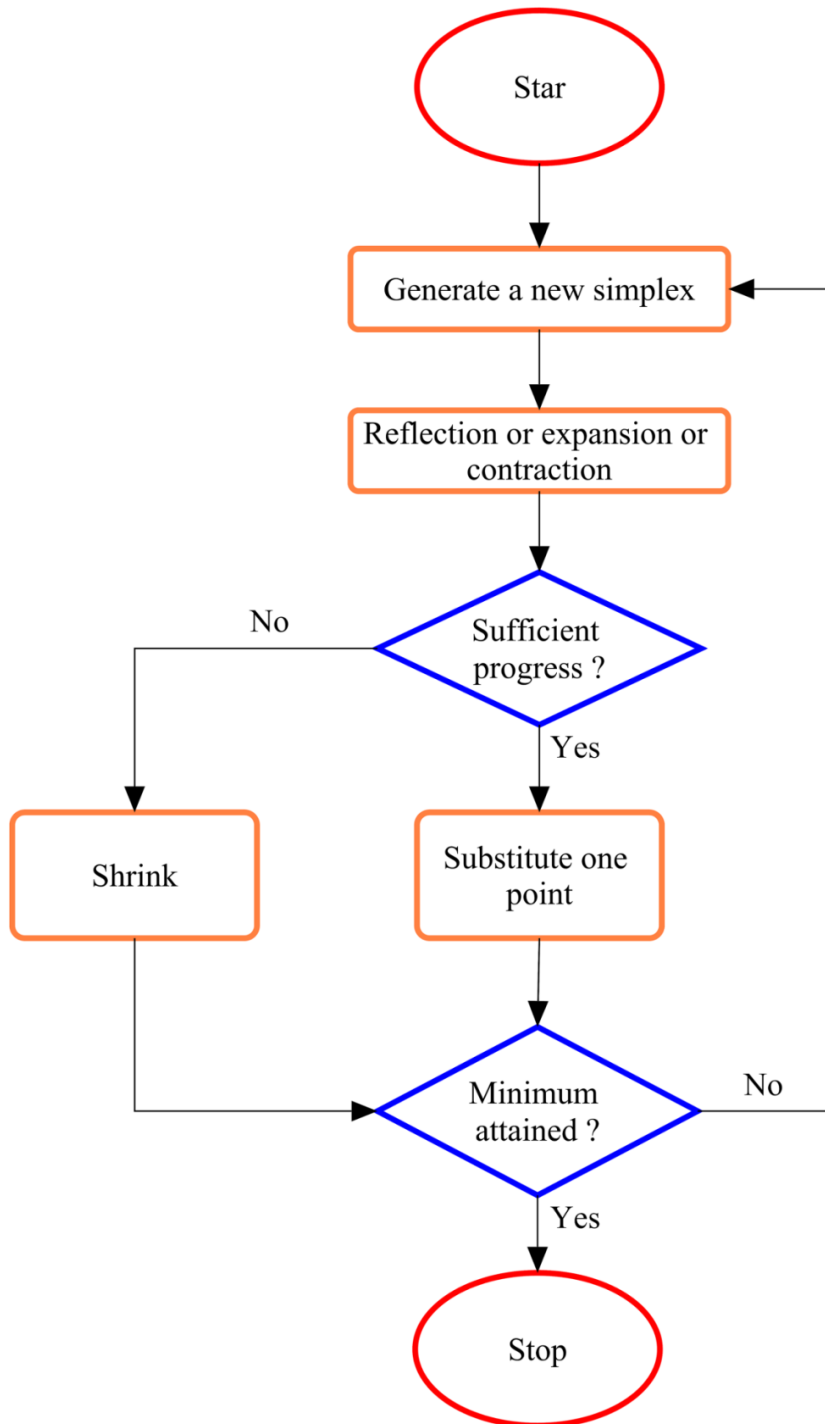

**Figure 4.2 :** Flowchart of the NM algorithm. (Adapted from Barati, 2011)

### 4.3.3 Random Search Algorithm

RS method known as a Monte-Carlo method is a stochastic algorithm and different from the most deterministic maximum search methods, such as Branch and Bound, Interval Analysis, and Tunneling methods. This property provides some advantages; for examples: Because small step methods can obtain only the top of a local peak, it should be combine with some variety of true search procedure if a search for the absolute maximum of a multimodal function is required. In the random process, there are a number of standard techniques and programs based on pseudo-random number generator. The resulting values have to be scaled and transformed in order to produce an approximation to any desired distribution. The main advantage which provide to appropriate usage of Random Search algorithms is that it is possible to reach the global optimum for non-convex, non-differentiable objective functions including continuous, discrete domains, or mixed of them for large-scale problems. Another advantage of RS method is that they are relatively easy to implement on complex problems. Generally, it is known that RS algorithms perform well and are “robust” in the sense that they give useful information quickly for ill-structured global optimization problems. The algorithm used in this study follows the procedure given in the Figure 4.3. Detail discussion of random search method can also be found in (Zabinsky, 2011; Karnopp, 1963).

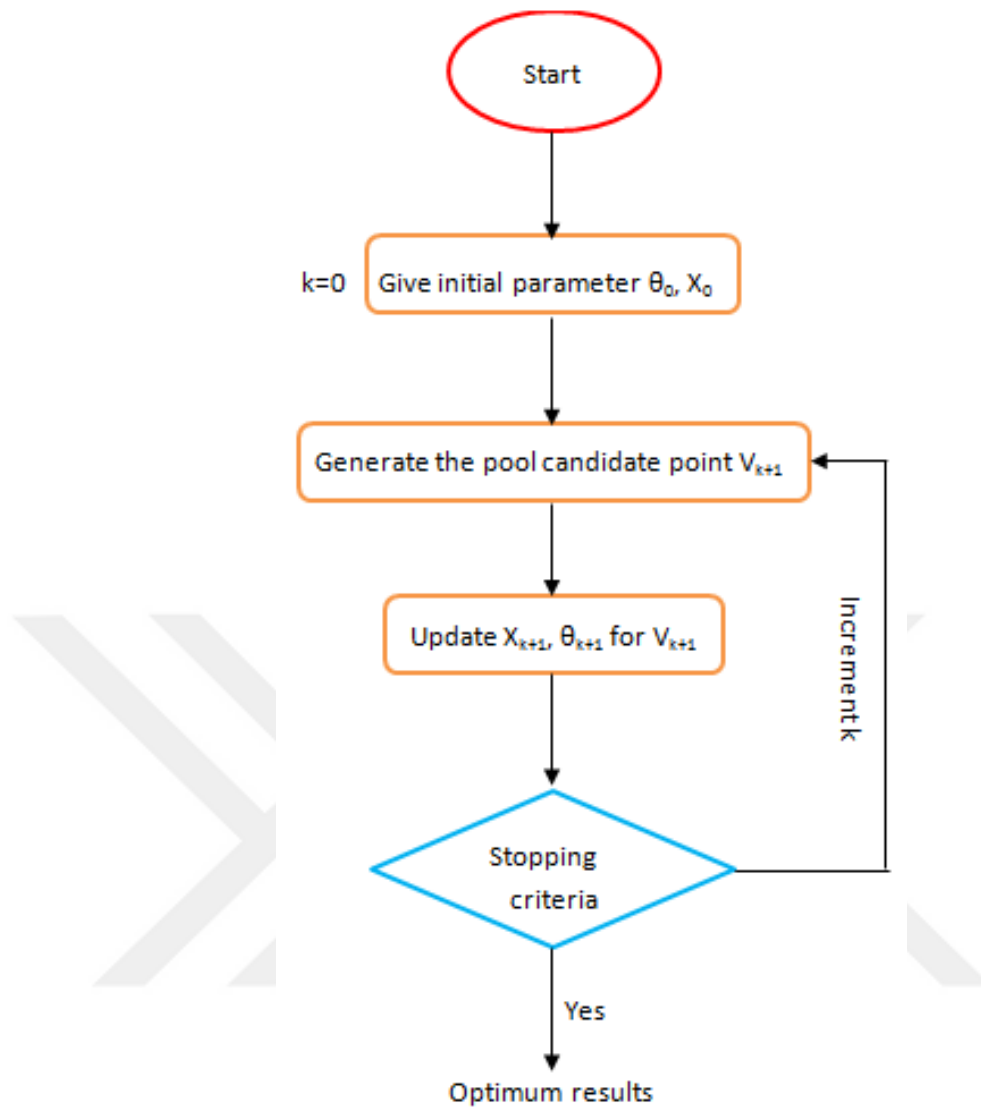

Figure 4.3 : Flowchart of the RS algorithm. (Adapted from Zabinsky, 2011)

### 4.3.4 Simulated Annealing Algorithm

One of the most popular random search methods is SA. It is based on the physical process of annealing, that a metal object is warmed up to a high temperature and permit to cool slowly. The melting process lets the atomic structure of the material to pass to a lower energy condition, hence that becoming a tougher material. From the view point of optimization, in SA algorithm, annealing process lets the structure to get away from a local minimum, and to explore and settle on a better global optimum point. The main advantage of SA is that that it enables to solve various optimization problems such as continuous, discrete or mixed-integer. In the working phase of this method, a new point is randomly produced at each iteration and when all stopping criteria are fulfilled the algorithm stops. The space of the new point from the current

point or the extent of the search is based on Boltzmann's probability distribution. The distribution implies the energy of a system in thermal equilibrium at temperature "T". Boltzmann's probability distribution can be expressed in the following form (Rao, 2009) :

$$P(E) = e^{-E/kT} \quad (4.1)$$

where  $P(E)$  represents the probability of achieving the energy level  $E$ ,  $k$  is the Boltzmann's constant, and  $T$  is temperature. In order to follow the procedure of the algorithm easily, the flowchart of a SA algorithm is presented in Figure 4.4.

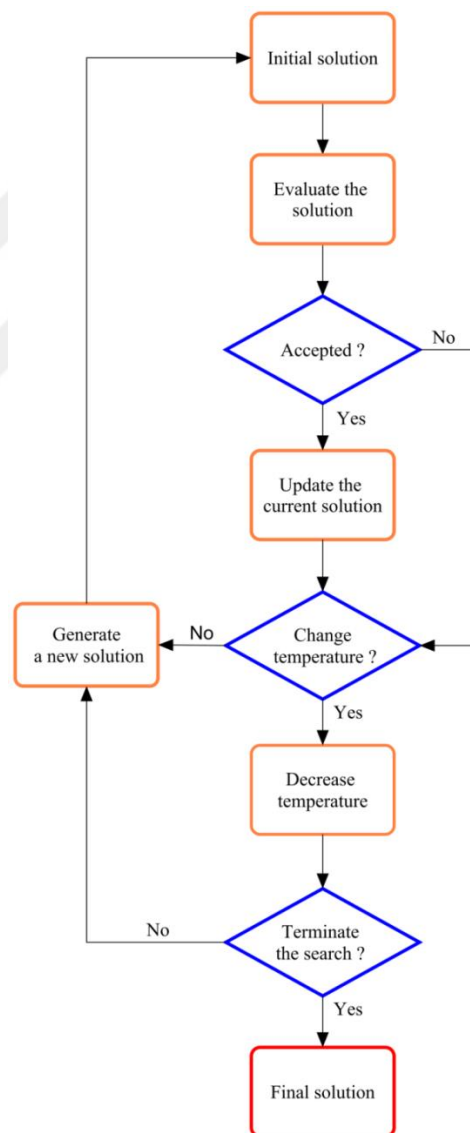

**Figure 4.4** : Flowchart of the SA algorithm. (Adapted from Pham and Karaboga, 2000)

Optimization methods options are given in Table 4.1.

**Table 4.1** : Four optimization methods options

Options Name	DE	NM	RS	SA
CrossProbability	0.5	-	-	-
RandomSeed	0	5/1/2/5	0	0
ScalingFactor	0.6	-	-	-
SearchPoints	-	-	3000	1000
Tolerance	0.001	0.001	0.001	0.001
ContractRatio	-	0.5	-	-
ExpandRatio	-	2.0	-	-
ReflectRatio	-	1.0	-	-
ShrinkRatio	-	0.5	-	-
LevelIterations	-	-	-	50
PerturbationScale	-	-	-	1.0



## CHAPTER 5

### STOCHASTIC OPTIMIZATION OF NON-HYBRID LAMINATED COMPOSITE FOR MAXIMUM FUNDAMENTAL FREQUENCY

Determination of the fundamental frequency performance of laminated composite plate is crucial for the design of the composite structures. Especially, in dynamical engineering systems, vibration have to be taken into account in order to prevent resonance arising from external excitations.

In this chapter, stacking sequences optimization problems for non-hybrid symmetric and symmetric balance graphite/epoxy, E-glass/epoxy and flax/epoxy laminated composite plates have been solved by utilizing Differential Evolution (DE), Nelder Mead (NM), Random Search (RS) and Simulated Annealing (SA) algorithms. The considered composite plates are rectangular and simply supported on four sides with length of  $a$  and width of  $b$  as shown in Figure 5.1.

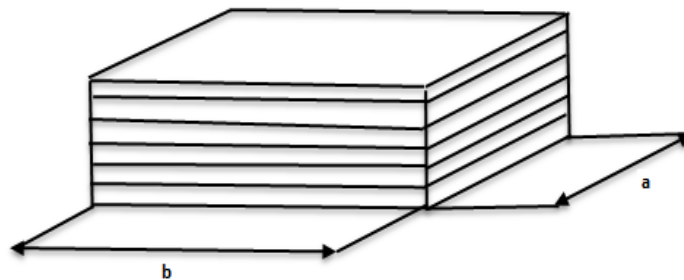

**Figure 5.1** : Laminated plate consisting of multiple laminate

Total thickness  $h$  equal to 2 mm and width of plate is 0.25 m.  $a$  has been calculated from the plate aspect ratio ( $a/b$ ). The elastic properties of composites given in Table 5.1 have been taken from (Tsai and Hahn, 1980; Liang et al., 2015)

**Table 5.1** Glass-epoxy, graphite-epoxy and flax-epoxy mechanical properties (Tsai and Hahn, 1980; Liang et al., 2015)

Parameters	Graphite-Epoxy	Glass-Epoxy	Flax-Epoxy
$E_1$ Longitudinal modulus (GPa)	181	38.6	22.8
$E_2$ Transverse Modulus (GPa)	10.3	8.27	4.52
$G_{12}$ In-plane shear modulus (GPa)	7.17	4.14	1.96
$V_{12}$ Poisson ratio	0.28	0.26	0.43
$\rho$ Material density (kg/m <sup>3</sup> )	1600	1800	1310

The main problem of this chapter is to design the stacking sequence of the graphite/epoxy, E-glass/epoxy and flax/epoxy laminated composites having high fundamental frequency. In order to gain the composite plate fulfilling this requirement, following optimization problems have been solved.

### **Problem 1**

The problem given in Abachizadeh and Tahani (2009) is selected as benchmark for fundamental frequency maximization with symmetric 8-layered graphite/epoxy (non-hybrid) and various aspect ratios by using the stochastic optimization methods: DE, NM, RS and SA. After that the obtained values are compared to results based on ACO (Abachizadeh and Tahani, 2009) method. Fiber orientation angles of the layers of the plate are considered in the range of -90 and 90 with 15 degree increments in order to take into account the manufacturing constraints.

### **Problem 2**

This problem is similar to the problem 1 but composite plate is symmetric and balance. The problem has been solved by four optimization methods: DE, NM, RS and SA.

### **Problem 3**

In order to compare between the fundamental frequency performance of discrete orientation (given in problem 2) and integer orientation design, fundamental frequency function has been maximized for symmetric-balance 8-layered graphite/epoxy with different aspect ratios and integer degree increments by utilizing the stochastic optimization methods: DE, NM, RS and SA.

#### **Problem 4**

The problem given in Abachizadeh and Tahani (2009) is selected as second benchmark to maximize the fundamental frequency with symmetric 16-layered glass/epoxy (non-hybrid) with different aspect ratios by utilizing four optimization methods DE, NM, RS and SA. In this validation case, fiber orientation angles of the layers of the plate are considered in the range of -90 and 90 with 45 degree increments.

#### **Problem 5**

This problem is similar to the problem 4 but composite plate is symmetric and balance. Problem has been solved four optimization methods: DE, NM, RS and SA.

#### **Problem 6**

The problem is similar to the problem 5. However, fiber orientation angles are selected as integer design variables so as to observe the effect of this orientation. Fundamental frequency function is maximized for symmetric-balance 16-layered glass/epoxy with different aspect ratios by utilizing the stochastic optimization methods: DE, NM, RS and SA.

#### **Problem 7**

The fundamental frequency for symmetric and symmetric-balance 16-layered flax/epoxy (non-hybrid) with different aspect ratios are maximized by utilizing the stochastic methods DE, NM, RS and SA in order to compare between the fundamental frequency performance of glass/epoxy (given in problem 4) and flax/epoxy laminated plates. Fiber orientation angles of the layers of the plate are considered in the range of -90 and 90 with 45 degree increments.

Table 5.2, 5.3 and 5.4 correspond to the problem 1, 2 and 3, respectively. The optimum stacking sequence designs of 8-layered symmetric graphite/epoxy laminated composites for maximum fundamental frequency using the proposed DE, NM, RS and SA algorithms and other popular algorithms (ACO, GA) are given in Table 5.2. The fundamental frequency values of graphite/epoxy composite vary in the range of 996.33-24389.90. It can be easily seen from the results that with increasing of the aspect ratios from 0.2 to 2, the optimum fiber orientation angles

increase from 0 to 90 degree. Furthermore, it is also found the fundamental frequency significantly changes (94%) for the aspect ratios from 0.2 to 1 while moderately changes (30%) from 1 to 2. Namely, as length of composite plate grows, fundamental frequency reduces. Even though, it is clearly seen from the results given in Table 5.2 that the designs of stacking sequences based on DE, NM, RS and SA comparing ACO (Abachizadeh and Tahani, 2009) and GA (Karakaya and Soykasap, 2011) are different for some of the aspect ratios, the maximum fundamental frequency values are the same. Also stacking sequences designs obtained using proposed algorithms (DE, NM, RS and SA) in this thesis are different each other. It can be seen that the problem is not large enough to deal with proposed algorithms.

The optimum stacking sequence designs of 8-layered symmetric-balance graphite/epoxy laminated composites for maximum fundamental frequency utilizing the proposed DE, NM, RS and SA algorithms are given in Tables 5.3 and 5.4. As mentioned earlier that with increasing of the aspect ratios from 0.2 to 2, the optimum fiber orientation angles are also increase in the interval  $[0,90]$ . Moreover, the value of fundamental frequency varies dramatically between 0.2 and 1 aspect ratio ( 94% ). The results given in Table 5.4 show that considering integer fiber angles can be obtained higher fundamental frequency for 0.8, 1.2, 1.4 and 1.8 aspect ratios. However, this increase is not a significant when the continuous and integer production challenge of fiber reinforced composites is taken into consideration. For this reason, discrete (15 degree increment) symmetric-balance graphite/epoxy is preferred optimum design.

By considering the results given in Tables 5.2, 5.3 and 5.4 together, it can be said that the fundamental frequency values of symmetric and symmetric-balance graphite/epoxy laminated composites are the same. It should be noted that symmetric-balance constraint prevents coupling between the normal - shear forces, bending - twisting moments and force-moment and reduces the number of design variables. Thus , this constraint is more advantage than symmetric constraint to solve optimization problems.

**Table 5.2 :** Comparison of optimum stacking sequences design in terms of fundamental frequencies for 8-layered symmetric non-hybrid graphite/epoxy laminates with  $15^0$  increment

a/b	ACO <sup>1</sup>	GA <sup>2</sup>	Stacking sequence			
			DE (present)	NM (present)	RS (present)	SA (present)
0.2	[0] <sub>4s</sub>	[0] <sub>4s</sub>	[0] <sub>4s</sub>	[0] <sub>4s</sub>	[0 <sub>3</sub> / 15] <sub>s</sub>	[0] <sub>4s</sub>
0.4	[0] <sub>4s</sub>	[0] <sub>4s</sub>	[0] <sub>4s</sub>	[0 <sub>3</sub> / 15] <sub>s</sub>	[0 <sub>3</sub> / 15] <sub>s</sub>	[0] <sub>4s</sub>
0.6	[±15] <sub>2s</sub>	[±15] <sub>2s</sub>	[±15 / -15] <sub>s</sub>	[15 / 0 ∓ 15] <sub>s</sub>	[∓15 / ±15] <sub>s</sub>	[-15 <sub>2</sub> / 15 <sub>2</sub> ] <sub>s</sub>
0.8	[±30] <sub>2s</sub>	[±30] <sub>2s</sub>	[±30] <sub>2s</sub>	[-30 <sub>3</sub> / 75] <sub>s</sub>	[30 <sub>2</sub> / -30 <sub>2</sub> ] <sub>s</sub>	[-30 <sub>3</sub> / 30] <sub>s</sub>
1	[±45] <sub>2s</sub>	[±45] <sub>2s</sub>	[-45 <sub>3</sub> / 45] <sub>s</sub>	[45 <sub>2</sub> / -45 <sub>2</sub> ] <sub>s</sub>	[∓45 / 45 / -30] <sub>s</sub>	[-45 <sub>2</sub> / 45 <sub>2</sub> ] <sub>s</sub>
1.2	[±45] <sub>2s</sub>	[±45] <sub>2s</sub>	[±45 / ∓45] <sub>s</sub>	[45 <sub>2</sub> / -45 <sub>2</sub> ] <sub>s</sub>	[∓45 / -60 / -45] <sub>s</sub>	[-45 <sub>3</sub> / 45] <sub>s</sub>
1.4	[±60] <sub>2s</sub>	[±60] <sub>2s</sub>	[-60 <sub>2</sub> / 60 <sub>2</sub> ] <sub>s</sub>	[60 <sub>2</sub> / -60 <sub>2</sub> ] <sub>s</sub>	[∓60 / ±60] <sub>s</sub>	[-60 <sub>3</sub> / 60] <sub>s</sub>
1.6	[±75] <sub>2s</sub>	[±75] <sub>2s</sub>	[∓75 / ±75] <sub>s</sub>	[75 <sub>2</sub> / 90 / -75] <sub>s</sub>	[75] <sub>4s</sub>	[-75] <sub>4s</sub>
1.8	[90] <sub>4s</sub>	[90] <sub>4s</sub>	[90] <sub>4s</sub>	[90] <sub>4s</sub>	[90] <sub>4s</sub>	[90] <sub>4s</sub>
2	[90] <sub>4s</sub>	[90] <sub>4s</sub>	[90] <sub>4s</sub>	[90] <sub>4s</sub>	[90] <sub>4s</sub>	[90] <sub>4s</sub>

<sup>1</sup>(Abachizadeh and Tahani, 2009), <sup>2</sup>(Karakaya and Soykasap, 2011)

**Table 5.2 (cont.) :** Comparison of optimum stacking sequences design in terms of fundamental frequencies for 8-layered symmetric non-hybrid graphite/epoxy laminates with  $15^0$  increment

a/b	ACO <sup>1</sup>	GA <sup>2</sup>	$\omega$ (rad/s)			
			DE (present)	NM (present)	RS (present)	SA (present)
0.2	24390	24390	24389.90	24389.90	24370.10	24389.90
0.4	6170	6170	6170.01	6166.97	6166.97	6170.01
0.6	2801	2801	2801.01	2800.67	2801.01	2801.01
0.8	1797	1797	1797.21	1790.75	1797.21	1797.21
1	1413	1413	1413	1413	1411.87	1413
1.2	1189	1189	1189.11	1189.11	1188.09	1189.11
1.4	1078	1078	1077.87	1077.87	1077.87	1077.87
1.6	1016	1016	1016.42	1015.86	1016.42	1016.42
1.8	1003	1003	1002.46	1002.46	1002.46	1002.46
2	996	996	996.33	996.33	996.33	996.33

<sup>1</sup>(Abachizadeh and Tahani, 2009), <sup>2</sup>(Karakaya and Soykasap, 2011)

**Table 5.3 :** Comparison of optimum stacking sequences design in terms of fundamental frequencies for 8-layered symmetric-balance non-hybrid graphite/epoxy laminates with  $15^0$  increment

a/b	Stacking sequence				$\omega$ (rad/s)			
	DE	NM	RS	SA	DE	NM	RS	SA
0.2	[0] <sub>4s</sub>	[0] <sub>4s</sub>	[0] <sub>4s</sub>	[0] <sub>4s</sub>	24389.90	24389.90	24389.90	24389.90
0.4	[0] <sub>4s</sub>	[0] <sub>4s</sub>	[0] <sub>4s</sub>	[0] <sub>4s</sub>	6170.01	6170.01	6170.01	6170.01
0.6	[∓15 / ±15] <sub>s</sub>	[±15] <sub>2s</sub>	[∓15 / ±15] <sub>s</sub>	[∓15 / ±15] <sub>s</sub>	2801.01	2801.01	2801.01	2801.01
0.8	[∓30 / ±30] <sub>s</sub>	[±45 / ±30] <sub>s</sub>	[∓30 / ±30] <sub>s</sub>	[∓30 / ±30] <sub>s</sub>	1797.21	1793.02	1797.21	1797.21
1	[∓45] <sub>2s</sub>	[±45 / ±30] <sub>s</sub>	[∓45 / ±45] <sub>s</sub>	[∓45] <sub>2s</sub>	1413	1403.91	1413	1413
1.2	[∓45] <sub>2s</sub>	[±45] <sub>2s</sub>	[∓45 / ±45] <sub>s</sub>	[∓45] <sub>2s</sub>	1189.11	1189.11	1189.11	1189.11
1.4	[±60] <sub>2s</sub>	[∓60] <sub>2s</sub>	[∓60] <sub>2s</sub>	[±60] <sub>2s</sub>	1077.87	1077.87	1077.87	1077.87
1.6	[∓75 / ±75] <sub>s</sub>	[90 <sub>2</sub> / ±75] <sub>s</sub>	[∓75 / ±75] <sub>s</sub>	[∓75 / ±75] <sub>s</sub>	1016.42	1011.93	1016.42	1016.42
1.8	[90] <sub>4s</sub>	[90] <sub>4s</sub>	[90] <sub>4s</sub>	[90] <sub>4s</sub>	1002.46	1002.46	1002.46	1002.46
2	[90] <sub>4s</sub>	[90] <sub>4s</sub>	[90] <sub>4s</sub>	[90] <sub>4s</sub>	996.33	996.33	996.33	996.33

**Table 5.4 :** Comparison of optimum stacking sequences design in terms of fundamental frequencies for 8-layered symmetric-balance non-hybrid graphite/epoxy laminates with integer design variables

a/b	Stacking sequence				$\omega$ (rad/s)			
	DE	NM	RS	SA	DE	NM	RS	SA
0.2	$[0]_{4s}$	$[0]_{4s}$	$[0_2 / \mp 4]_s$	$[0]_{4s}$	24389.90	24389.90	24378.10	24389.90
0.4	$[0]_{4s}$	$[0]_{4s}$	$[0_2 / \mp 4]_s$	$[0]_{4s}$	6170.01	6170.01	6168.24	6170.01
0.6	$[\pm 12]_{2s}$	$[\pm 12]_{2s}$	$[\pm 12]_{2s}$	$[\mp 12]_{2s}$	2801.80	2801.80	2801.80	2801.80
0.8	$[\pm 37]_{2s}$	$[\pm 37]_{2s}$	$[\pm 37 / \mp 38]_s$	$[\mp 37]_{2s}$	1815.88	1815.88	1815.86	1815.88
1	$[\mp 45 / \pm 45]_s$	$[\pm 45]_{2s}$	$[\pm 44 / \pm 45]_s$	$[\mp 45]_{2s}$	1413	1413	1412.69	1413
1.2	$[\mp 51 / \pm 51]_s$	$[\mp 51 / \pm 51]_s$	$[\pm 51 / \pm 52]_s$	$[\mp 51 / \pm 51]_s$	1199.24	1199.24	1199.21	1199.24
1.4	$[\mp 58 / \pm 58]_s$	$[\mp 58 / \pm 58]_s$	$[\mp 58 / \mp 60]_s$	$[\mp 58]_{2s}$	1078.34	1078.34	1078.28	1078.34
1.6	$[\pm 70]_{2s}$	$[\mp 70]_{2s}$	$[\pm 70]_{2s}$	$[\mp 70 / \pm 70]_s$	1017.44	1017.44	1017.44	1017.44
1.8	$[90]_{4s}$	$[90]_{4s}$	$[90]_{4s}$	$[90]_{4s}$	1002.46	1002.46	1002.46	1002.46
2	$[90]_{4s}$	$[90]_{4s}$	$[90]_{4s}$	$[90]_{4s}$	996.33	996.34	996.35	996.36

Table 5.5, 5.6 and 5.7 correspond to the problem 4, 5 and 6, respectively. The optimum stacking sequence design of 16-layered symmetric E-glass/epoxy laminated composite for maximum fundamental frequency using the proposed DE, NM, RS and SA algorithms and other popular algorithms (ACO, GA) are given in Table 5.5. The fundamental frequency values of E-glass/epoxy composite vary in the range of 455.47-10747. The results show that the fundamental frequency varies with the plate aspect ratio nonlinearly. (i.e., 94% from 0.2 to 1, 30% from 1 to 2). Although, stacking sequences design of laminated composite based on DE, NM, RS and SA comparing ACO (Abachizadeh and Tahani, 2009) and GA (Karakaya and Soykasap, 2011) are different for some of the aspect ratios, the maximum fundamental frequency values are the same.

**Table 5.5 :** Comparison of optimum stacking sequences design in terms of fundamental frequencies for 16-layered symmetric non-hybrid E-glass/epoxy laminates with  $45^0$  increment

a/b	Stacking sequence				
	ACO <sup>1</sup> and GA <sup>2</sup>	DE (present)	NM (present)	RS (present)	SA (present)
0.2	$[0]_{8s}$	$[0]_{8s}$	$[0]_{8s}$	$[0_6 / \mp 45]_s$	$[0]_{8s}$
0.4	$[0]_{8s}$	$[0]_{8s}$	$[0]_{8s}$	$[0_6 / \mp 45]_s$	$[0]_{8s}$
0.6	$[0]_{8s}$	$[0]_{8s}$	$[0]_{8s}$	$[0_6 / \mp 45]_s$	$[0]_{8s}$
0.8	$[\pm 45]_{4s}$	$[-45 / 45_3 / -45_4]_s$	$[\pm 45 / \mp 45 / \pm 45 / 45_2]_s$	$[-45_3 / \pm 45_2 / -45]_s$	$[-45_4 / 45_2 / \mp 45]_s$
1	$[\pm 45]_{4s}$	$[\pm 45_2 / \mp 45_2]_s$	$[\pm 45 / \mp 45 / \pm 45 / 45_2]_s$	$[-45_3 / \pm 45_2 / -45]_s$	$[-45 / \mp 45_2 / \pm 45 / -45]_s$
1.2	$[\pm 45]_{4s}$	$[45 / \pm 45_2 / \mp 45 / 45]_s$	$[\pm 45 / \mp 45_2 / 45_2]_s$	$[-45_3 / \pm 45_2 / -45]_s$	$[\mp 45_2 / 45_2 / \mp 45]_s$
1.4	$[\pm 45]_{4s}$	$[\pm 45]_{4s}$	$[\mp 45 / \pm 45 / 45_2 / -45_2]_s$	$[-45_3 / \pm 45_2 / -45]_s$	$[-45_6 / 45_2]_s$
1.6	$[90]_{8s}$	$[90]_{8s}$	$[90]_{8s}$	$[90_5 / -45 / \pm 45]_s$	$[90]_{8s}$
1.8	$[90]_{8s}$	$[90]_{8s}$	$[90]_{8s}$	$[90_5 / -45 / \pm 45]_s$	$[90]_{8s}$
2	$[90]_{8s}$	$[90]_{8s}$	$[90]_{8s}$	$[90_5 / -45 / \pm 45]_s$	$[90]_{8s}$

<sup>1</sup>(Abachizadeh and Tahani, 2009), <sup>2</sup>(Karakaya and Soykasap, 2011)

**Table 5.5 (cont.)** : Comparison of optimum stacking sequences design in terms of fundamental frequencies for 16-layered symmetric non-hybrid E-glass/epoxy laminates with 45<sup>0</sup> increment

a/b	ACO <sup>1</sup>	GA <sup>2</sup>	$\omega$ (rad/s)			
			DE (present)	NM (present)	RS (present)	SA (present)
0.2	10747	10747.03	10747	10747	10747	10747
0.4	2776	2776.31	2776.31	2776.31	2768.47	2776.31
0.6	1305	1304.89	1304.90	1304.90	1303.50	1304.90
0.8	843	843.40	843.41	843.41	843.41	843.41
1	663	662.75	662.76	662.76	662.76	662.76
1.2	559	558.93	558.94	558.94	558.94	558.94
1.4	493	493.02	493.02	493.02	493.02	493.02
1.6	474	473.84	473.84	473.84	472.53	473.84
1.8	463	463.01	463.02	463.02	460.68	463.02
2	455	455.46	455.47	455.47	452.38	455.47

<sup>1</sup>(Abachizadeh and Tahani, 2009), <sup>2</sup>(Karakaya and Soykasap, 2011)

The optimum stacking sequence designs of 16-layered symmetric-balance E-glass/epoxy laminated composites for maximum fundamental frequency utilizing the proposed DE, NM, RS and SA algorithms are given in Tables 5.6 and 5.7. The results show that symmetric-balance constraint can be used without decrease frequency for E-glass/epoxy composite plate. In addition to this, it is observed that the usage of integer design variables instead of discrete design variables can not take any advantage in terms of frequency. Especially, RS method tends to catch local point and give worse frequency results than discrete design for 0.2 and 0.4 aspect ratios.

**Table 5.6** : Comparison of optimum stacking sequences design in terms of fundamental frequencies for 16-layered symmetric-balance non-hybrid E-glass/epoxy laminates with 45<sup>0</sup> increment

a/b	Stacking sequence			
	DE	NM	RS	SA
0.2	[0] <sub>8s</sub>	[0 <sub>4</sub> / $\pm 45_2$ ] <sub>s</sub>	[0] <sub>8s</sub>	[0] <sub>8s</sub>
0.4	[0] <sub>8s</sub>	[0 <sub>4</sub> / $\pm 45$ / $\mp 45$ ] <sub>s</sub>	[0] <sub>8s</sub>	[0] <sub>8s</sub>
0.6	[0] <sub>8s</sub>	[0 <sub>4</sub> / $\pm 45$ / 0 <sub>2</sub> ] <sub>s</sub>	[0] <sub>8s</sub>	[0] <sub>8s</sub>
0.8	[ $\pm 45_2$ / $\mp 45$ / $\pm 45$ ] <sub>s</sub>	[ $\pm 45_4$ ] <sub>s</sub>	[ $\mp 45_2$ / $\pm 45$ / $\mp 45$ ] <sub>s</sub>	[ $\pm 45_2$ / $\mp 45$ / $\pm 45$ ] <sub>s</sub>
1	[ $\mp 45$ / $\pm 45_2$ / $\mp 45$ ] <sub>s</sub>	[ $\pm 45_4$ ] <sub>s</sub>	[ $\mp 45_2$ / $\pm 45$ / $\mp 45$ ] <sub>s</sub>	[ $\mp 45$ / $\pm 45_2$ / $\mp 45$ ] <sub>s</sub>
1.2	[ $\mp 45_3$ / $\pm 45$ ] <sub>s</sub>	[ $\pm 45_4$ ] <sub>s</sub>	[ $\mp 45_2$ / $\pm 45$ / $\mp 45$ ] <sub>s</sub>	[ $\mp 45_3$ / $\pm 45$ ] <sub>s</sub>
1.4	[ $\pm 45$ / $\mp 45_3$ ] <sub>s</sub>	[ $\pm 45_3$ / $\mp 45$ ] <sub>s</sub>	[ $\mp 45_2$ / $\pm 45$ / $\mp 45$ ] <sub>s</sub>	[ $\pm 45$ / $\mp 45_3$ ] <sub>s</sub>
1.6	[90] <sub>8s</sub>	[90] <sub>8s</sub>	[90] <sub>8s</sub>	[90] <sub>8s</sub>
1.8	[90] <sub>8s</sub>	[90] <sub>8s</sub>	[90] <sub>8s</sub>	[90] <sub>8s</sub>
2	[90] <sub>8s</sub>	[90] <sub>8s</sub>	[90] <sub>8s</sub>	[90] <sub>8s</sub>

**Table 5.6 (cont) :** Comparison of optimum stacking sequences design in terms of fundamental frequencies for 16-layered symmetric-balance non-hybrid E-glass/epoxy laminates with  $45^\circ$  increment

a/b	$\omega$ (rad/s)			
	DE	NM	RS	SA
0.2	10747	10398.40	10747	10747
0.4	2776.31	2712.93	2776.31	2776.31
0.6	1304.90	1295.11	1304.90	1304.90
0.8	843.41	843.41	843.41	843.41
1	662.76	662.76	662.76	662.76
1.2	558.94	558.94	558.94	558.94
1.4	493.02	493.02	493.02	493.02
1.6	473.84	473.84	473.84	473.84
1.8	463.02	463.02	463.02	463.02
2	455.47	455.47	455.47	455.47

**Table 5.7 :** Comparison of optimum stacking sequences design in terms of fundamental frequencies for 16-layered symmetric-balance non-hybrid E-glass/epoxy laminates with integer design variables

a/b	Stacking sequence			
	DE	NM	RS	SA
0.2	$[0]_{8s}$	$[0_4 / \pm 1 / \mp 2]_s$	$[\pm 3 / \pm 6 / \mp 5 / \mp 30]_s$	$[0_6 / \mp 2]_s$
0.4	$[0]_{8s}$	$[0_6 / \pm 8]_s$	$[\pm 3 / \pm 6 / \mp 5 / \mp 30]_s$	$[0_2 / \pm 1_2 / 0_2]_s$
0.6	$[\pm 6 / \mp 6 / \pm 6]_s$	$[\pm 6_2 / \mp 7 / \pm 6]_s$	$[\mp 7 / \mp 5 / \mp 7 / \pm 13]_s$	$[\pm 6 / \mp 6 / \mp 5 / \mp 6]_s$
0.8	$[\mp 37 / \pm 37 / \mp 37]_s$	$[\mp 37 / \pm 36 / \pm 37 / \pm 25]_s$	$[\pm 37 / \pm 36 / \mp 33 / \pm 52]_s$	$[\mp 37_2 / \pm 37 / \mp 33]_s$
1	$[\pm 45 / \mp 45 / \pm 45 / \mp 45]_s$	$[\pm 45_2 / \mp 46 / \mp 45]_s$	$[\pm 43 / \pm 42 / \mp 53 / \pm 41]_s$	$[\mp 45_2 / \pm 44 / \pm 43]_s$
1.2	$[\mp 51 / \pm 51 / \mp 51]_s$	$[\pm 51_2 / \mp 51]_s$	$[\pm 50 / \pm 52 / \mp 49 / 90]_s$	$[\pm 51 / \mp 51 / \pm 51 / \mp 55]_s$
1.4	$[\pm 59 / \mp 59 / \pm 59 / \mp 59]_s$	$[\pm 59 / \pm 60 / \mp 60 / \mp 56]_s$	$[\mp 59 / \pm 66 / \pm 58 / \mp 66]_s$	$[\pm 59_2 / \pm 60 / \mp 61]_s$
1.6	$[\pm 73_3 / \mp 73]_s$	$[\pm 73_2 / \mp 73]_s$	$[\pm 73_2 / \pm 78 / \pm 87]_s$	$[\pm 73_2 / \pm 72 / \mp 76]_s$
1.8	$[90]_{8s}$	$[90]_{8s}$	$[90]_{8s}$	$[90]_{8s}$
2	$[90]_{8s}$	$[90]_{8s}$	$[90]_{8s}$	$[90]_{8s}$

**Table 5.7 (cont.) :** Comparison of optimum stacking sequences design in terms of fundamental frequencies for 16-layered symmetric-balance non-hybrid E-glass/epoxy laminates with integer design variables

a/b	$\omega$ (rad/s)			
	DE	NM	RS	SA
0.2	10747	10746.70	10684.10	10747
0.4	2776.31	2776	2766.49	2776.19
0.6	1304.95	1304.95	1304.94	1304.95
0.8	851.88	851.64	851.22	851.86
1	662.76	662.74	661.39	662.74
1.2	562.58	562.58	561.73	562.56
1.4	505.51	505.49	504.86	505.51
1.6	475.06	475.06	475.01	475.06
1.8	463.02	463.02	463.02	463.02
2	455.47	455.47	455.47	455.47

In the case of a non-hybrid structural design, the optimal stacking sequence design of 16-layered symmetric and symmetric-balance flax/epoxy composites in terms of fundamental frequency for problem 7 are given in Table 5.8 and Table 5.9. The fundamental frequency values of flax/epoxy composite vary in the range of 413.37-9786.39.



Although stacking sequences of symmetric and symmetric balance flax/epoxy laminated composites are different for various aspect ratios, their fundamental frequency performances are the same for DE and SA optimization methods.

NM and RS methods tend to catch local point, thus these methods give different results for symmetric and symmetric-balance cases. The results given in Tables ( 5.5, 5.6, 5.8 and 5.9) show that if the flax/epoxy is used as an alternative bio based composite material instead of E- glass/epoxy, fundamental frequency decrease up to 9%.

**Table 5.8 :** Comparison of optimum stacking sequences design in terms of fundamental frequencies for 16-layered symmetric non-hybrid flax/epoxy laminates with  $45^0$  increment

a/b	Stacking sequence			
	DE	NM	RS	SA
0.2	$[0]_{8s}$	$[0]_{8s}$	$[0_6 / -45 / 45]_s$	$[0]_{8s}$
0.4	$[0]_{8s}$	$[0]_{8s}$	$[0_6 / -45 / 45]_s$	$[0]_{8s}$
0.6	$[0]_{8s}$	$[0]_{8s}$	$[0_6 / -45 / 45]_s$	$[0]_{8s}$
0.8	$[-45 / 45_3 / -45_4]_s$	$[\pm 45 / \mp 45 / \pm 45 / 45_2]_s$	$[-45_3 / \pm 45_2 / -45]_s$	$[-45_4 / 45 / -45_3]_s$
1	$[\pm 45_2 / \mp 45_2]_s$	$[\pm 45 / \mp 45 / \pm 45 / 45_2]_s$	$[-45_3 / \pm 45_2 / -45]_s$	$[-45 / 45_5 / -45_2]_s$
1.2	$[45 / \pm 45_2 / \mp 45 / 45]_s$	$[\pm 45 / \mp 45 / -45_2 / 45_2]_s$	$[-45_3 / \pm 45_2 / -45]_s$	$[-45_8]_s$
1.4	$[-45_2 / 45_2 / -45_4]_s$	$[\mp 45 / \pm 45 / 45_2 / -45_2]_s$	$[-45_3 / \pm 45_2 / -45]_s$	$[-45_3 / 45_2 / -45_2 / 45]_s$
1.6	$[90]_{8s}$	$[90]_{8s}$	$[90_5 / -45 / \pm 45]_s$	$[90]_{8s}$
1.8	$[90]_{8s}$	$[90]_{8s}$	$[90_5 / -45 / \pm 45]_s$	$[90]_{8s}$
2	$[90]_{8s}$	$[90]_{8s}$	$[90_5 / -45 / \pm 45]_s$	$[90]_{8s}$

**Table 5.8 (cont.) :** Comparison of optimum stacking sequences design in terms of fundamental frequencies for 16-layered symmetric non-hybrid flax/epoxy laminates with  $45^0$  increment

a/b	$\omega$ (rad/s)			
	DE	NM	RS	SA
0.2	9786.39	9786.39	9746.38	9786.39
0.4	2523.28	2523.28	2515.97	2523.28
0.6	1182.30	1182.30	1181.01	1182.30
0.8	763.24	763.24	763.24	763.24
1	599.91	599.91	599.91	599.91
1.2	505.85	505.85	505.85	505.85
1.4	446.02	446.02	446.02	446.02
1.6	429.13	429.13	427.91	429.13
1.8	419.84	419.84	417.66	419.84
2	413.37	413.37	410.49	413.37

**Table 5.9 :** Comparison of optimum stacking sequences design in terms of fundamental frequencies for 16-layered symmetric-balance non-hybrid flax/epoxy laminates with  $45^0$  increment

a/b	Stacking sequence			
	DE	NM	RS	SA
0.2	$[0]_{8s}$	$[0_4 / \pm 45 / 0_2]_s$	$[0]_{8s}$	$[0]_{8s}$
0.4	$[0]_{8s}$	$[0_4 / \pm 45 / 0_2]_s$	$[0]_{8s}$	$[0]_{8s}$
0.6	$[0]_{8s}$	$[0]_{8s}$	$[0]_{8s}$	$[0]_{8s}$
0.8	$[\pm 45_2 / \mp 45 / \pm 45]_s$	$[\mp 45 / \pm 45_3]_s$	$[\mp 45_2 / \pm 45 / \mp 45]_s$	$[\mp 45_3 / \pm 45]_s$
1	$[\mp 45 / \pm 45_2 / \mp 45]_s$	$[\pm 45_3 / 0_2]_s$	$[\mp 45_2 / \pm 45 / \mp 45]_s$	$[\mp 45_4]_s$
1.2	$[\mp 45_3 / \pm 45]_s$	$[\mp 45 / \pm 45 / 90_2 / \pm 45]_s$	$[\mp 45_2 / \pm 45 / \mp 45]_s$	$[\mp 45 / \pm 45_3 / ]_s$
1.4	$[\mp 45 / \pm 45 / \mp 45_2]_s$	$[\mp 45 / \pm 45 / 90_2 / \pm 45]_s$	$[\mp 45_2 / \pm 45 / \mp 45]_s$	$[\mp 45 / \pm 45_2 / \mp 45]_s$
1.6	$[90]_{8s}$	$[90]_{8s}$	$[90]_{8s}$	$[90]_{8s}$
1.8	$[90]_{8s}$	$[90]_{8s}$	$[90]_{8s}$	$[90]_{8s}$
2	$[90]_{8s}$	$[90]_{8s}$	$[90]_{8s}$	$[90]_{8s}$

**Table 5.9 (cont.) :** Comparison of optimum stacking sequences design in terms of fundamental frequencies for 16-layered symmetric-balance non-hybrid flax/epoxy laminates with  $45^0$  increment

a/b	DE	NM	$\omega$ (rad/s)	
			RS	SA
0.2	9786.39	9502.80	9786.39	9786.39
0.4	2523.28	2471.64	2523.28	2523.28
0.6	1182.30	1182.30	1182.30	1182.30
0.8	763.24	763.24	763.24	763.24
1	599.91	598.55	599.91	599.91
1.2	505.85	501.62	505.85	505.85
1.4	446.02	445.70	446.02	446.02
1.6	429.13	429.13	429.13	429.13
1.8	419.84	419.84	419.84	419.84
2	413.37	413.37	413.37	413.37

It can be discovered from the results presented in Tables (5.2-5.8) that if fundamental frequency is considered as an objective function, the results regarding graphite fiber give the higher values comparing glass and flax fiber ones.

The results based on stochastic optimization algorithms DE, NM, RS and SA have been compared to results given in Abachizadeh and Tahani (2009) by ACO method and Soykasap and Karakaya (2011) by GA for the same laminated composite structure design and optimization problems. Regarding the results, DE, NM, RS and SA show comparable performance to obtain the maximum fundamental frequency. Generally, DE and SA methods give same results for same problems but NM and RS methods sometimes denote different results from them because NM and RS have tend to catch local point in complex problems.

## Chapter 6

### STOCHASTIC OPTIMIZATION OF GRAPHITE-GLASS/EPOXY INTERPLY HYBRID LAMINATED COMPOSITE FOR MAXIMUM FUNDAMENTAL FREQUENCY AND MINIMUM COST

In previous section, the stacking sequence optimization of graphite/epoxy, glass/epoxy and flax/epoxy composites have been carried out based on single objective approach. It should be noted that problems 1-7 don't include hybrid structural design and they have only evaluated in terms of fundamental frequency. However, cost is a crucial factor for all the engineering problems and therefore, it has to be taken into account in the design an optimization problems of the laminated composite materials. In this chapter, design of graphite-glass/epoxy interply hybrid laminated composite to maximize the fundamental frequency and minimize the cost based on multi objective optimization approach is considered. The design variables of the optimization problems are selected as fiber orientation angles and the number of outer layers ( $N_o$ ) having high-stiffness and more expensive and the number of inner layers ( $N_i$ ) having low-stiffness and inexpensive. Hybrid construction provides both suitable structural rigidity and low cost and weight simultaneously. Therefore, multi objective optimization approach is usually preferred in the solution of the design problems for interply hybrid laminated composite. In contrast to the traditional multi objective optimization approach the usage of penalty function formulation may be appropriate because of that it has advantage of turning constrained optimization problems into the unconstrained ones. Thanks to this, it can be applied to the problem by any of the unconstrained methods. Now, In order to evaluate both of the quantities frequency and cost, a function  $F$  can be introduced as linear combination of the squares of the parameters  $f_1, f_2, g_1, g_2$  as :

$$F = k_1 f_1^2 + k_2 f_2^2 + c_1 g_1^2 + c_2 g_2^2 \quad (6.1)$$

where the parameters  $f_1, f_2, g_1, g_2, k_1, k_2, c_1,$  and  $c_2$  can be defined as

$$f_1 = \left( \frac{\omega_{\max} - \omega}{\omega_{\max}} \right) \quad (6.2)$$

$$f_2 = \left( \frac{\text{cost}}{\text{cost}_{\max}} \right) \quad (6.3)$$

$$g_1 = \delta - 0.2 \quad (6.4)$$

$$g_2 = \gamma - 0.2 \quad (6.5)$$

$$k_1 = k_2 = c_1 = c_2 = 1 \quad (6.6)$$

The parameters  $\omega$  and cost occurs in Eqs. (6.2) and (6.3) represent optimum frequency and cost values. The parameters  $\omega_{\max}$  and  $\text{cost}_{\max}$  indicate the maximum fundamental frequency and maximum cost for all layers being consisted of non-hybrid graphite/epoxy layered. Namely, the numerical value of  $\omega_{\max}$  is based on the results of problem 1, which can also be utilized for corresponding aspect ratios in problem 8-14. In Eqs. (6.4–6.6),  $g_1$  and  $g_2$  are the penalty terms, the other parameters,  $k_1, k_2, c_1,$  and  $c_2$  are sensitivity coefficients depending on weights of the objective functions in the optimization problem. The value of the parameters ( $k_1, k_2, c_1$  and  $c_2$ ) are selected as 1 due to objective functions (fundamental frequency and cost) have to be assumed equally important.

$$\text{cost} = ab \frac{h}{N} g(\alpha_0 \rho_0 N_0 + \rho_i N_i) \quad (6.7)$$

where  $a$  and  $b$  are the length and width of the plate, respectively;  $N_0$  and  $N_i$  are the number of outer and inner layers, total number of layers is  $N=N_0 +N_i$ ;  $\rho_0$  and  $\rho_i$  are the mass densities of the outer (graphite/epoxy) and inner (glass/epoxy) layers, respectively.  $\alpha_0$  is comparative cost ratio of the graphite/epoxy layer to glass/epoxy. ( $\alpha_0=8$ ).

In order to evaluate performance of graphite-glass/epoxy hybrid structure concerning fundamental frequency and cost are solved five different problems (8-12). The results based on stochastic optimization algorithms DE, NM and SA have been compared to results given in Abachizadeh and Tahani (2009) by ACO, Tahani

et al. (2005) by GA and Kolahan et al. (2005) by SA methods for the same laminated composite structure design and optimization problems.

### **Problem 8**

The problem given in Abachizadeh and Tahani (2009) is selected as third benchmark for the laminate comprising symmetric 8-layered hybrid graphite-glass/epoxy. The optimization problem is to find the number of high stiffness and less expensive laminates maximizing the fundamental frequency and minimizing the cost by multi objective optimization approach. Fiber orientation angles of the layers of the plate are considered in the range of -90 and 90 with 15 degree increments. The stochastic search methods DE, NM and SA are used and then obtained results are also compared to results based on ACO, GA and SA given in ( Abachizadeh and Tahani, 2009; Tahani et al., 2005; Kolahan et al., 2005).

### **Problem 9**

The problem is similar to problem 8 such that multi objective optimization in order to maximize fundamental frequency and minimize cost including various aspect ratios of the laminated plates. However, composite plate is symmetric-balance. Fiber orientation angles of the layers are considered in the range of -90 and 90 with 15 degree increments. The stochastic optimization methods DE, NM and SA are used.

### **Problem 10**

The problem is just an extension of Problem 9 for 28-layered symmetric-balance graphite-glass/epoxy hybrid composites by using the stochastic optimization method DE, NM and SA.

### **Problem 11**

Organization of the problem is similar to problem 9 and 10 such that multi objective optimization in order to maximize fundamental frequency and minimize cost comprising different aspect ratios of the laminated composite plates. However, in order to see the reliability and robustness of stochastic methods, 48-layered symmetric-balance graphite-glass/epoxy hybrid composites are considered. The stochastic optimization methods DE, NM and SA are utilized.

## Problem 12

Stacking sequence design and optimization of 8, 28 and 48-layered symmetric-balance graphite-glass/epoxy hybrid composites are carried out so as to maximize fundamental frequency and minimize cost. Fiber orientation angles of the layers are considered in the range of  $-90$  and  $90$  with continuous/ $1^\circ/5^\circ/30^\circ$  increments for 0.8 aspect ratio. The stochastic optimization methods DE, NM and SA are utilized.

The optimum stacking sequence designs of 8-layered graphite-glass/epoxy symmetric hybrid composite for minimum index F (Problem 8), fundamental frequency and cost are given in Table 6.1. By comparing the results based on proposed algorithms DE, NM and SA with ACO (Abachizadeh and Tahani, 2009), it is seen that although optimum stacking sequences designs are different for some of the aspect ratios, the frequency, cost and F values are the same. Furthermore, the stochastic algorithms DE, NM and SA show superior performance than GA (Tahani et al., 2005) and SA (Kolahan et al., 2005) in terms of frequency. The fundamental frequency and cost values of graphite-glass/epoxy composite vary in the range of 784 – 19093 and 0.1138- 1.1375, respectively. The mean of F values becomes 0.1712.

When compared the results obtained using non-hybrid symmetric graphite/epoxy (Table 5.2) with the results obtained using hybrid symmetric graphite-glass/epoxy (Table 6.1), it can be seen that fundamental frequency decrease 21%, material cost decreases 64%. Namely, hybrid laminated composites can be used to decrease cost without sacrificing from fundamental frequency.

**Table 6.1 :** Comparison of optimum stacking sequences design in terms of index F and corresponding values on fundamental frequencies and cost for 8-layered symmetric hybrid graphite-glass/epoxy laminates with  $15^0$  increment

a/b	ACO <sup>1</sup>	GA <sup>2</sup>	SA <sup>3</sup>	Stacking sequence			N <sub>0</sub>
				DE (present)	NM (present)	SA (present)	
0.2	[0] <sub>4s</sub>	[0] <sub>4s</sub>	[0] <sub>4s</sub>	[0] <sub>4s</sub>	[0 / -30 / 0 / 15] <sub>s</sub>	[0] <sub>4s</sub>	2
0.4	[0] <sub>4s</sub>	[0] <sub>4s</sub>	[0] <sub>4s</sub>	[0] <sub>4s</sub>	[0] <sub>4s</sub>	[0 <sub>s</sub> / 15] <sub>s</sub>	2
0.6	[15 / 0 <sub>3</sub> ] <sub>s</sub>	[0 / 30 / -30] <sub>2s</sub>	[0 / 15 / -30 / -15] <sub>s</sub>	[-15 / 0 <sub>3</sub> ] <sub>s</sub>	[±15 / 0 <sub>2</sub> ] <sub>s</sub>	[-15 / 0 <sub>3</sub> ] <sub>s</sub>	2
0.8	[±30] <sub>2s</sub>	[0 / 45 / -45] <sub>2s</sub>	[0 / 30 / -45] <sub>2s</sub>	[∓30] <sub>2s</sub>	[-30 <sub>3</sub> / 30] <sub>s</sub>	[∓30 / -30] <sub>2s</sub>	2
1	[±45] <sub>2s</sub>	[-45 / 45] <sub>3s</sub>	[-45 / 45] <sub>3s</sub>	[∓45 / 45] <sub>2s</sub>	[-45 <sub>2</sub> / 45 / 15] <sub>s</sub>	[∓45] <sub>2s</sub>	2
1.2	[±45] <sub>2s</sub>	[90 / -45 / 45] <sub>2s</sub>	[90 / -45 / 45] <sub>2s</sub>	[-45] <sub>4s</sub>	[-45 <sub>2</sub> / 45 / 30] <sub>s</sub>	[∓45 / -45] <sub>2s</sub>	2
1.4	[±60] <sub>2s</sub>	[90 / 60 / -60] <sub>2s</sub>	[90 / 60 <sub>2</sub> / -60] <sub>2s</sub>	[∓60 / ±60] <sub>s</sub>	[-60 <sub>2</sub> / 60 / 30] <sub>s</sub>	[∓60 / ±60] <sub>s</sub>	2
1.6	[±75] <sub>2s</sub>	[90 / -75 / 60] <sub>2s</sub>	[90 / 75 <sub>2</sub> / 60] <sub>s</sub>	[-75 <sub>2</sub> / ±75] <sub>s</sub>	[-75 <sub>2</sub> / 75] <sub>2s</sub>	[∓75 / ±75] <sub>s</sub>	2
1.8	[90] <sub>4s</sub>	[90] <sub>4s</sub>	[90] <sub>4s</sub>	[90] <sub>4s</sub>	[90] <sub>4s</sub>	[90] <sub>4s</sub>	2
2	[90] <sub>4s</sub>	[90] <sub>4s</sub>	[90] <sub>4s</sub>	[90] <sub>4s</sub>	[90] <sub>4s</sub>	[90] <sub>4s</sub>	2

<sup>1</sup>(Abachizadeh and Tahani, 2009), <sup>2</sup>(Tahani et al., 2005), <sup>3</sup>(Kolahan et al., 2005)

**Table 6.1 (cont.) :** Comparison of optimum stacking sequences design in terms of index F and corresponding values on fundamental frequencies and cost for 8-layered symmetric hybrid graphite-glass/epoxy laminates with  $15^0$  increment

a/b	ACO <sup>1</sup>	GA <sup>2</sup>	SA <sup>3</sup>	$\omega$ (rad/s)			Cost All methods	ACO <sup>1</sup>	F		
				DE (present)	NM (present)	SA (present)			DE (present)	NM (present)	SA (present)
0.2	19093	19093	19093	19093.13	18822.09	19093.13	0.1138	0.1732	0.1735	0.1785	0.1735
0.4	4844	4844.30	4844.30	4844.27	4844.27	4843.63	0.2275	0.1725	0.1725	0.1724	0.1726
0.6	2210	2252.30	2232.50	2210.40	2210.20	2210.40	0.3413	0.1707	0.1708	0.1708	0.1708
0.8	1421	1339.50	1334.20	1420.69	1420.69	1420.69	0.4550	0.1708	0.1702	0.1691	0.1702
1	1116	1047.30	1047.30	1116.21	1115.55	1116.21	0.5687	0.1705	0.1705	0.1707	0.1705
1.2	940	855.64	855.64	939.66	939.33	939.66	0.6825	0.1706	0.1704	0.1705	0.1704
1.4	851	820.40	820.40	851.45	850.95	851.45	0.7963	0.1705	0.1704	0.1707	0.1705
1.6	802	800.15	799.80	802.48	802.48	802.48	0.9100	0.1709	0.1707	0.1705	0.1707
1.8	790	790.07	790.07	790.07	790.07	790.07	1.0238	0.1714	0.1712	0.1712	0.1712
2	784	784.04	784.04	784.04	784.04	784.04	1.1375	0.1720	0.1718	0.1718	0.1718

<sup>1</sup>(Abachizadeh and Tahani, 2009), <sup>2</sup>(Tahani et al., 2005), <sup>3</sup>(Kolahan et al., 2005)

**Table 6.2 :** Comparison of optimum stacking sequences design in terms of index F and corresponding values on fundamental frequencies and cost for 8-layered symmetric-balance hybrid graphite-glass/epoxy laminates with  $15^0$  increment

a/b	Stacking sequence			$N_0$	$\omega$ (rad/s)			Cost	F		
	DE	NM	SA		DE	NM	SA	DE/NM/SA	DE	NM	SA
0.2	$[0]_{4s}$	$[0]_{4s}$	$[0]_{4s}$	2	19093.13	19093.13	19093.13	0.1138	0.1735	0.1735	0.1735
0.4	$[0]_{4s}$	$[0]_{4s}$	$[0]_{4s}$	2	4844.27	4844.27	4844.27	0.2275	0.1725	0.1725	0.1725
0.6	$[\pm 15 / 0_2]_s$	$[\pm 15 / 0_2]_s$	$[\mp 15 / 0_2]_s$	2	2210.20	2210.20	2210.20	0.3413	0.1708	0.1708	0.1708
0.8	$[\pm 30 / \mp 30]_s$	$[\mp 30 / \pm 30]_s$	$[\pm 30]_{2s}$	2	1420.69	1420.69	1420.69	0.4550	0.1702	0.1695	0.1702
1	$[\pm 45 / \mp 45]_s$	$[\mp 45 / \pm 45]_s$	$[\mp 45 / \pm 45]_s$	2	1116.21	1116.21	1116.21	0.5687	0.1705	0.1684	0.1705
1.2	$[\mp 45 / \pm 45]_s$	$[\mp 45 / 90_2]_s$	$[\mp 45 / \pm 45]_s$	2	939.66	936.52	939.66	0.6825	0.1704	0.1715	0.1704
1.4	$[\mp 60]_{2s}$	$[\mp 60]_{2s}$	$[\mp 60]_{2s}$	2	851.45	851.45	851.45	0.7963	0.1705	0.1705	0.1705
1.6	$[\mp 75 / \pm 75]_s$	$[\pm 75 / \mp 75]_s$	$[\mp 75 / \pm 75]_s$	2	802.48	802.48	802.48	0.9100	0.1707	0.1692	0.1707
1.8	$[90]_{4s}$	$[90]_{4s}$	$[90]_{4s}$	2	790.07	790.07	790.07	1.0238	0.1712	0.1712	0.1712
2	$[90]_{4s}$	$[90]_{4s}$	$[90]_{4s}$	2	784.04	784.04	784.04	1.1375	0.1718	0.1718	0.1718



Table 6.2 corresponds to problem 9. The composite plates considered in this problem are symmetric-balanced. Therefore, the number of design variables decreases from 8 to 2. The fundamental frequency and cost values of graphite-glass/epoxy composite vary in the range of 784 – 19093 and 0.1138- 1.1375, respectively. The mean of F values becomes 0.1712. By evaluating the results given in Tables 6.1 and 6.2 together, it is said that symmetric-balance constraint can be used without decrease frequency for graphite-glass/epoxy hybrid composite plate. Also, in problem 9, hybrid structure decreases the cost (64 %) without significant losing from fundamental frequency (%21) similarly with the previous problem.

Table 6.3 shows the optimum stacking sequence designs of 28-layered symmetric-balance graphite-glass/epoxy hybrid composites in terms of index F (Problem 10), fundamental frequency and cost. The graphite-glass/epoxy composite, the fundamental frequency and cost values change between 754 - 18339 and 0.1039 – 1.0393, respectively. The mean of F values is also calculated as 0.1639.

A close look at the results given in Table 6.3 clearly demonstrate that the proposed algorithms DE, NM and SA are capable of providing maximum fundamental frequency and minimum cost comparable with ACO (Abachizadeh and Tahani, 2009). Moreover, Table 6.3 clearly indicates that proposed algorithms DE, NM and SA exhibit superior performance in terms of fundamental frequency as compared GA (Tahani et al., 2005) and SA (Kolahan et al., 2005) algorithms.

When Tables 6.3 and 5.3 are evaluated together, It is seen that fundamental frequency decreases 24% and material cost decreases 67.5% using hybrid structure.

**Table 6.3 :** Comparison of optimum stacking sequences design in terms of index F and corresponding values on fundamental frequencies and cost for 28-layered symmetric-balance hybrid graphite-glass/epoxy laminates with  $15^0$  increment

a/b	ACO <sup>1</sup>	N <sub>0</sub>	GA <sup>2</sup>	N <sub>0</sub>	SA <sup>3</sup>	Stacking sequence			N <sub>0</sub>	
						N <sub>0</sub>	DE (present)	NM (present)		SA (present)
0.2	[0] <sub>14s</sub>	6	[0 <sub>12</sub> / 15 <sub>2</sub> ] <sub>s</sub>	4	[0 <sub>2</sub> / -15 / 0 <sub>2</sub> / 15 / 0 / 15 / 0 / 15 <sub>2</sub> / -15 / 15 <sub>2</sub> ] <sub>s</sub>	4	[0] <sub>14s</sub>	[0 <sub>4</sub> / ±15 / ∓15 / 0 <sub>2</sub> / ±15 / 0 <sub>2</sub> ] <sub>s</sub>	[0 <sub>6</sub> / ±15 / 0 <sub>2</sub> / ±15 / ∓60] <sub>s</sub>	6
0.4	[0] <sub>14s</sub>	6	[0 / ±15 / 0 / 15 / 0 <sub>2</sub> / -15 / 0 <sub>3</sub> / 15 / 0 <sub>2</sub> ] <sub>s</sub>	4	[0 <sub>2</sub> / 15 / 0 <sub>2</sub> / -15 <sub>3</sub> / 15 <sub>2</sub> / -15 <sub>3</sub> / 15] <sub>s</sub>	4	[0] <sub>14s</sub>	[0 <sub>6</sub> / ∓15 / 0 <sub>2</sub> / ±30 / 0 <sub>2</sub> ] <sub>s</sub>	[0 <sub>6</sub> / ±15 / 0 <sub>2</sub> / ±15 / ∓60] <sub>s</sub>	6
0.6	[15 <sub>3</sub> / 0 <sub>11</sub> ] <sub>s</sub>	6	[30 / -30 <sub>4</sub> / 45 / ±30 <sub>2</sub> / 30 / -45 / -30 <sub>2</sub> ] <sub>s</sub>	4	[±30 <sub>2</sub> / 45 <sub>2</sub> / 30 / 45 / ±30 / ∓30 / 45 / 30] <sub>s</sub>	4	[±15 <sub>2</sub> / 0 <sub>10</sub> ] <sub>s</sub>	[∓15 / 0 <sub>2</sub> / ±15 / 0 <sub>4</sub> / ±15 / 0 <sub>2</sub> ] <sub>s</sub>	[∓15 / ±15 / 0 <sub>2</sub> / ±15 / ∓15 / 0 <sub>2</sub> / ±30] <sub>s</sub>	6
0.8	[±30] <sub>7s</sub>	6	[∓45 <sub>3</sub> / 45 / ±45 / ∓45 / 30 / -45 <sub>2</sub> ] <sub>s</sub>	4	[45 / -45 <sub>3</sub> / ±45 <sub>2</sub> / -30 / ∓45 <sub>2</sub> / -30 / 45 / 30] <sub>s</sub>	4	[±30 <sub>4</sub> / ∓30 / ±30 <sub>2</sub> ] <sub>s</sub>	[∓30 <sub>2</sub> / ±30 / ∓30 / ±30 / ±15 / ±30] <sub>s</sub>	[∓30 <sub>2</sub> / ±30 <sub>2</sub> / ∓45 <sub>3</sub> ] <sub>s</sub>	6
1	[±45] <sub>7s</sub>	6	[45 <sub>2</sub> / -45 <sub>4</sub> / ±45 <sub>2</sub> / -45 <sub>2</sub> / 45 <sub>2</sub> ] <sub>s</sub>	4	[45 <sub>2</sub> / -45 <sub>4</sub> / ±45 <sub>2</sub> / -45 <sub>2</sub> / 45 <sub>2</sub> ] <sub>s</sub>	4	[∓45 / ±45 <sub>2</sub> / ∓45 <sub>3</sub> / ±45] <sub>s</sub>	[±45 / ∓45 / ±60 / ∓45 / ∓30 / ∓15 / ±45] <sub>s</sub>	[∓45 / ±45 <sub>2</sub> / ∓45 <sub>3</sub> / ±60] <sub>s</sub>	6
1.2	[±45] <sub>7s</sub>	6	[-45 / 45 <sub>3</sub> / ∓45 / -60 / ∓45 / -45 <sub>2</sub> / 45 / -45 <sub>2</sub> ] <sub>s</sub>	6	[-45 / 45 <sub>3</sub> / ∓45 / -60 / ∓45 / -45 <sub>2</sub> / 45 / -45 <sub>2</sub> ] <sub>s</sub>	4	[∓45 / ±45 <sub>6</sub> ] <sub>s</sub>	[±45 / ±60 / ±45 <sub>2</sub> / ∓45 / ∓15 / ±30] <sub>s</sub>	[±45 / ∓45 <sub>2</sub> / ±45 <sub>2</sub> / ∓45 / ∓75] <sub>s</sub>	6
1.4	[±60] <sub>7s</sub>	6	[±60 / ∓60 / ±60 / -45 / -60 <sub>3</sub> / 60 / -45 <sub>2</sub> / 60] <sub>s</sub>	6	[±60 <sub>3</sub> / -60 <sub>2</sub> / -45 <sub>2</sub> / 60 <sub>2</sub> / -45 <sub>2</sub> ] <sub>s</sub>	6	[∓60 / ±60 <sub>4</sub> / ∓60 <sub>2</sub> ] <sub>s</sub>	[±60 <sub>3</sub> / ±75 / ±45 / ±15 / ±30] <sub>s</sub>	[±60 / ∓60 <sub>3</sub> / ±60 <sub>2</sub> / ±45] <sub>s</sub>	6
1.6	[±75] <sub>7s</sub>	6	[±60 / 60 <sub>2</sub> / 75 / ∓60 / 75 / ±60 / -60 / -75 / 60 / -75] <sub>s</sub>	6	[∓60 / -60 / 75 / 60 <sub>2</sub> / 75 <sub>2</sub> / ∓60 / -60 <sub>3</sub> / 60] <sub>s</sub>	6	[∓75 <sub>6</sub> / ±75] <sub>s</sub>	[±75 / ∓75 / ±75 <sub>2</sub> / 90 <sub>2</sub> / ±45 <sub>2</sub> ] <sub>s</sub>	[∓75 / ±75 / ∓75 / 90 <sub>4</sub> / ∓75 <sub>2</sub> ] <sub>s</sub>	6
1.8	[90] <sub>14s</sub>	6	[90] <sub>14s</sub>	6	[90] <sub>14s</sub>	6	[90] <sub>14s</sub>	[90] <sub>14s</sub>	[90] <sub>14s</sub>	6
2	[90] <sub>14s</sub>	6	[90] <sub>14s</sub>	6	[90] <sub>14s</sub>	6	[90] <sub>14s</sub>	[90] <sub>14s</sub>	[90] <sub>14s</sub>	6

<sup>1</sup>(Abachizadeh and Tahani, 2009), <sup>2</sup>(Tahani et al., 2005), <sup>3</sup>(Kolahan et al., 2005)

**Table 6.3 (cont.)** : Comparison of optimum stacking sequences design in terms of index F and corresponding values on fundamental frequencies and cost for 28-layered symmetric-balance hybrid graphite-glass/epoxy laminates with  $15^0$  increment

a/b	$\omega$ (rad/s)						Cost	F			
	ACO <sup>1</sup>	GA <sup>2</sup>	SA <sup>3</sup>	DE (present)	NM (present)	SA (present)	ACO/DE/ NM/SA	ACO <sup>1</sup>	DE (present)	NM (present)	SA (present)
0.2	18339	16518	16461	18339	18256.70	18298.20	0.1039	0.1667	0.1670	0.1687	0.1679
0.4	4656	4286.70	4227.20	4656.20	4648.49	4649.48	0.2079	0.1657	0.1657	0.1663	0.1662
0.6	2127	1960.50	1946	2127.08	2126.83	2126.93	0.3118	0.1632	0.1634	0.1634	0.1634
0.8	1368	1277.20	1276	1367.75	1367.34	1367.59	0.4157	0.1631	0.1626	0.1618	0.1626
1	1074	1007.60	1007.60	1074.44	1070.12	1074.40	0.5196	0.1629	0.1629	0.1620	0.1629
1.2	905	879.30	879.30	904.57	901.71	904.52	0.6236	0.1630	0.1627	0.1639	0.1628
1.4	820	849.70	849.70	819.58	817.21	819.56	0.7275	0.1629	0.1629	0.1640	0.1629
1.6	772	785.14	785	772.35	771.93	772.23	0.8314	0.1633	0.1631	0.1617	0.1632
1.8	760	760.08	760.08	760.09	760.09	760.09	0.9354	0.1641	0.1639	0.1639	0.1639
2	754	754.01	754.01	754.01	754.01	754.01	1.0393	0.1649	0.1646	0.1646	0.1646

<sup>1</sup>(Abachizadeh and Tahani, 2009), <sup>2</sup>(Tahani et al., 2005), <sup>3</sup> (Kolahan et al., 2005)

**Table 6.4** : Comparison of optimum stacking sequences design in terms of index F and corresponding values on fundamental frequencies and cost for 48-layered symmetric-balance hybrid graphite-glass/epoxy laminates with  $15^0$  increment

a/b	DE	Stacking sequence				
		$N_0$	NM	$N_0$	SA	
0.2	$[0]_{24s}$	10	$[0_{10} / \pm 30 / 0_6 / \mp 15 / \pm 30 / 0_2]_s$	10	$[0_8 / \mp 15 / 0_2 / 90_2 / \pm 15 / 0_2 / \pm 30 / 90_2 / \mp 60]_s$	10
0.4	$[0]_{24s}$	10	$[0_{10} / \pm 15_2 / \pm 30 / \mp 15 / 0_2 / \pm 30 / 0_2]_s$	10	$[0_8 / \mp 30 / \pm 15 / \mp 30 / \mp 15 / \pm 15_3 / 90_2]_s$	10
0.6	$[\mp 15_2 / 0_{20}]_s$	8	$[\pm 15 / \mp 15 / 0_2 / \mp 15 / 0_4 / \pm 15 / 0_6 / \pm 15 / 0_2]_s$	8	$[0_2 / \pm 15 / \mp 15 / 0_2 / \pm 15_3 / \mp 15_3 / \pm 45 / \mp 75]_s$	8
0.8	$[\pm 30 / \mp 30 / \pm 30_4 / \mp 30 / \pm 30 / \mp 30_2 / \pm 45 / \mp 60]_s$	8	$[\pm 30 / \mp 30 / \pm 30_3 / 0_2 / \pm 45 / 0_2 / \pm 15 / \pm 30 / \pm 60 / \pm 30]_s$	8	$[\mp 30 / \pm 30 / \mp 45_2 / \pm 30_2 / \mp 45_2 / 0_2 / \pm 45 / \mp 30 / \mp 15]_s$	8
1	$[\mp 45_3 / \pm 45 / \mp 45 / \pm 45 / \mp 45_3 / \pm 30 / 90_2 / \pm 15]_s$	10	$[\mp 45_4 / \mp 30 / \pm 45_4 / \mp 30 / \pm 45 / \mp 30]_s$	10	$[\pm 45 / \mp 45_2 / \pm 45_2 / \mp 45 / \mp 60 / \mp 45 / \pm 60 / \mp 30 / \mp 15 / \pm 30]_s$	8
1.2	$[\mp 45 / \pm 45 / \mp 45 / \pm 45 / \mp 45_3 / \pm 45 / \mp 45 / \pm 45 / \mp 15 / \pm 15]_s$	8	$[\mp 45_2 / \mp 60 / \mp 45_2 / \pm 45_3 / \pm 30 / \mp 15 / \pm 30 / \mp 30]_s$	8	$[\pm 45_2 / \mp 45 / \mp 60 / \pm 45 / \mp 60 / \pm 60 / \mp 30 / \mp 45 / \pm 45 / 90_4]_s$	8
1.4	$[\mp 60 / \pm 60 / \mp 60 / \pm 60 / \mp 60 / \pm 60 / \mp 60_3 / \mp 45 / 90_4]_s$	8	$[\mp 60_5 / \pm 60 / \pm 75 / \pm 60 / \pm 45 / \mp 45 / \pm 45 / \mp 15]_s$	10	$[\pm 60 / \mp 60_3 / \pm 60 / \mp 60 / \mp 75 / 90_6 / \pm 60 / 90_2]_s$	8
1.6	$[\pm 75_3 / \mp 75 / \pm 75 / \mp 75_2 / 90_4 / \pm 75 / 90_4]_s$	8	$[\mp 75_4 / 90_2 / \pm 75_4 / \mp 75 / \pm 60 / \mp 75]_s$	10	$[\mp 75_2 / 90_4 / \mp 75 / 90_2 / \mp 75 / \pm 60 / \mp 75_2 / \mp 60 / \mp 45]_s$	8
1.8	$[90]_{24s}$	10	$[90_{12} / \pm 75 / 90_2 / \mp 75 / 90_2 / \pm 75 / \mp 60]_s$	8	$[90_8 / \pm 75 / \mp 75 / 90_6 / \pm 75 / \pm 60 / \mp 15]_s$	10
2	$[90]_{24s}$	10	$[90_4 / \mp 75 / 90_{14} / \pm 60 / \mp 75]_s$	8	$[90_{12} / \mp 60 / \mp 75 / 90_2 / \pm 60 / 90_2 / \pm 75]_s$	10

**Table 6.4 (cont.) :** Comparison of optimum stacking sequences design in terms of index F and corresponding values on fundamental frequencies and cost for 48-layered symmetric-balance hybrid graphite-glass/epoxy laminates with  $15^0$  increment

a/b	$\omega$ (rad/s)			Cost			F		
	DE	NM	SA	DE	NM	SA	DE	NM	SA
0.2	18204.10	18128.70	18014.30	0.1023	0.1023	0.1023	0.1665	0.1681	0.1705
0.4	4622.60	4610.19	4592.49	0.2046	0.2046	0.2046	0.1651	0.1661	0.1676
0.6	1999.38	1999.25	1998.36	0.2725	0.2725	0.2725	0.1625	0.1625	0.1627
0.8	1286.48	1282.08	1284.93	0.3633	0.3633	0.3633	0.1613	0.1618	0.1618
1	1066.56	1065.37	1008.82	0.5115	0.5115	0.4542	0.1623	0.1603	0.1624
1.2	850.46	849.28	849.43	0.5450	0.5450	0.5450	0.1617	0.1622	0.1622
1.4	770.54	813.29	769.69	0.6358	0.7160	0.6358	0.1619	0.1624	0.1623
1.6	726.05	766.89	725.71	0.7267	0.8183	0.7267	0.1622	0.1608	0.1624
1.8	754.73	713.87	754.30	0.9206	0.8175	0.9206	0.1633	0.1635	0.1635
2	748.65	707.17	747.50	1.0229	0.9083	1.0229	0.1640	0.1648	0.1646

Table 6.4 shows the optimum stacking sequence designs of 48-layered symmetric-balance graphite-glass/epoxy hybrid composites in terms of index F (Problem 10), fundamental frequency and cost. The graphite-glass/epoxy composite, the fundamental frequency and cost values change between 748.65 – 18204.10 and 0.1023 – 1.0229, respectively. The mean of F values is also calculated as 0.1631. It can be easily seen from the results given in Table 6.4 that proposed algorithms DE, NM and SA exhibit different performance in terms of fundamental frequency, cost and index F. The proposed algorithms calculate different values the number of graphite layers which is one of the design parameters. For instance number of graphite layers are found as 8 and 10 for different aspect ratio by SA. The results in this case indicate that the number of layers of 48 is critical for this problem. When Table 6.4 and 5.3 are evaluated together, it is seen that fundamental frequency decrease 27% and material cost decreases 71% by using hybrid structure. In order to denote whether the advantage of utilizing continuous fiber angles in stacking sequence designs of 8/28/48-layered symmetric-balance graphite-glass/epoxy, continuous designs and discrete designs whose increment of fiber angles are  $1^0/5^0/30^0$  have been performed for  $a/b = 0.8$  plate aspect ratios and the result have been given in Table 6.5. The results based on DE, NM and SA indicate that the laminated composites designed using continuous design variables provide higher fundamental frequency performance than designed using discrete design variables. However, this increase have not a significant effect when the continuous and discrete production challenge of fiber reinforced composites is taken into consideration.

**Table 6.5 :** Comparison of optimum stacking sequences design in terms of index F and corresponding values on fundamental frequencies and cost for 8/28/48-layered symmetric-balance hybrid graphite-glass/epoxy laminates with  $\text{cont}/1^0/5^0/30^0$  increments

a/b	Ply number	DE	NM	SA	$N_0$
0.8	8 ply	$[\pm 37.3 / \mp 36.9]_s$	$[\mp 37.3 / \mp 36.9]_s$	$[\mp 37.3 / \mp 36.9]_s$	2
		$[\pm 37 / \mp 37]_s$	$[\mp 37]_{2s}$	$[\mp 37]_{2s}$	2
		$[\mp 35]_{2s}$	$[\mp 35 / \mp 40]_s$	$[\mp 35 / \pm 35]_s$	2
		$[\mp 30_2]_s$	$[\mp 30_2]_s$	$[\mp 30]_{2s}$	2
	28 ply	$[\mp 37.3 / \mp 37.3 / \mp 36.9 / \pm 36.9 / \mp 36.9_3]_s$	$[\pm 37.3 / \mp 37.3 / \pm 36.8 / \mp 36.8_2 / \pm 36.8_2]_s$	$[\pm 37.3 / \mp 37.3 / \mp 36.9_2 / \pm 36.9 / \mp 36.9 / \pm 36.9]_s$	6
		$[\mp 37 / \pm 37 / \pm 36 / \mp 36 / \mp 34 / \pm 39 / \mp 44]_s$	$[\pm 37 / \mp 37 / \pm 36 / \mp 35 / \mp 36 / \pm 16 / \pm 39]_s$	$[\mp 38 / \mp 36 / \pm 43 / \pm 32 / \pm 56 / \pm 31 / \pm 33]_s$	6
		$[\pm 35_3 / \mp 35_2 / \pm 35_2]_s$	$[\pm 35 / \mp 40 / \pm 35 / \mp 30 / \mp 20 / \pm 20 / \pm 25]_s$	$[\pm 40 / \pm 35 / \mp 40 / \mp 30 / \pm 30_2 / \pm 55]_s$	6
		$[\pm 30 / \mp 30_2 / \pm 30_4]_s$	$[\pm 30 / \mp 30 / \pm 30_2 / \mp 30 / \pm 30_2]_s$	$[\mp 30_2 / \pm 30_2 / \mp 30_3]_s$	6
	48 ply	$[\pm 37.3 / \mp 37.3 / \mp 36.9 / \pm 36.9 / \mp 36.9 / \pm 36.9]_s$	$[\pm 37.3 / \mp 37.3 / \pm 36.9_5 / \mp 36.9 / \pm 36.9_4]_s$	$[\pm 37.3_2 / \pm 36.9_2 / \mp 36.9_2 / \pm 36.9 / \mp 36.9_2 / \pm 36.9_3]_s$	8
		$[\pm 37 / \mp 38 / \mp 37 / \pm 40 / \mp 35 / \pm 38 / \pm 39 / \pm 5 / \mp 35 / \pm 34 / \pm 60 / \pm 33]_s$	$[\pm 38 / \mp 39 / \pm 35 / \pm 36 / \pm 41 / \pm 34 / \pm 32 / \mp 36 / \pm 27 / \pm 34 / \pm 75 / \pm 66]_s$	$[\pm 36 / \pm 40 / \pm 30 / \pm 41 / \mp 41_2 / \pm 42 / \mp 57 / \mp 1 / \pm 62 / \pm 59 / \pm 77]_s$	8
		$[\pm 35 / \mp 40_2 / \pm 40 / \pm 35 / \pm 30 / \mp 35 / \mp 45 / \mp 40 / \mp 20 / \pm 30 / \mp 55]_s$	$[\pm 40_2 / \pm 35 / \mp 35 / \pm 30 / \pm 75 / \mp 30 / \pm 20 / \mp 50 / \pm 15 / \pm 10 / \pm 40]_s$	$[\pm 35_2 / \mp 35 / \pm 35 / \pm 40 / \mp 40 / \pm 50 / \mp 55 / \pm 45 / \mp 75 / \pm 30 / \pm 65]_s$	8
		$[\mp 30_2 / \pm 30_2 / \mp 30_3 / \pm 30 / \mp 30 / \pm 30 / \mp 30 / \pm 30]_s$	$[\mp 30_5 / \pm 30_4 / \mp 30 / \pm 30 / \mp 30]_s$	$[\mp 30 / \pm 30_4 / \mp 30_3 / \pm 30_2 / 0_2 / \pm 30]_s$	8

**Table 6.5 (cont.) :** Comparison of optimum stacking sequences design in terms of index F and corresponding values on fundamental frequencies and cost for 8/28/48-layered symmetric-balance hybrid graphite-glass/epoxy laminates with  $\text{cont}/1^0/5^0/30^0$  increments

a/b	Ply number	$\omega$ (rad/s)			Cost	DE	F	
		DE	NM	SA	DE/NM/SA		NM	SA
0.8	8	1434.54	1434.54	1434.54	0.4550	0.1671	0.1663	0.1671
		1434.51	1434.51	1434.51	0.4550	0.1671	0.1663	0.1671
		1433.08	1433.08	1433.08	0.4550	0.1674	0.1667	0.1674
		1420.69	1420.69	1420.69	0.4550	0.1702	0.1695	0.1702
0.8	28	1380.87	1380.87	1380.87	0.4157	0.1591	0.1591	0.1591
		1380.77	1380.35	1378.29	0.4157	0.1592	0.1593	0.1598
		1379.49	1377.77	1378.46	0.4157	0.1595	0.1599	0.1598
		1367.75	1367.34	1367.59	0.4157	0.1626	0.1618	0.1626
0.8	48	1298.50	1298.50	1298.50	0.3633	0.1576	0.1566	0.1576
		1296.84	1297.29	1293.78	0.3633	0.1581	0.1570	0.1590
		1296.28	1295.11	1294.23	0.3633	0.1583	0.1577	0.1589
		1286.52	1286.52	1286.38	0.3633	0.1613	0.1604	0.1614

Change of fundamental frequency and cost which depend on number of graphite layers and aspect ratios for 28 and 48 layered symmetric balance hybrid composite plates are given in Figure 6.1. It is observed that increase in fundamental frequency becomes significant by the number of graphite layers reach to 20 for 28 layered laminated composite. When considered the effect of the number of graphite layers on change of fundamental frequency for 48 layered plate, frequency increases dramatically by the number of graphite layers reach to 34 graphite layers. As number of graphite layers and aspect ratios rise for 28 and 48 layered structures cost increase linearly. Figure 6.2 shows that the percentage reduction of fundamental frequency and cost for different aspect ratios when the composite structure is made entirely of graphite and the increasing number of graphite layers is taken into account. When Figures 6.1 and 6.2 are evaluated together, It is seen that with increasing the aspect ratios from 0.2 to 2, fundamental frequency decreases and cost increases but percentage reduction of frequency and cost are independent from aspect ratio for different number of graphite layers.

It can be deduced from the results presented in Tables (6.1-6.5) that if fundamental frequency and cost are considered as an objective function simultaneously, hybrid structure including graphite/epoxy in outer layers and glass/epoxy in inner layers can be preferred to obtain high frequency and low cost.

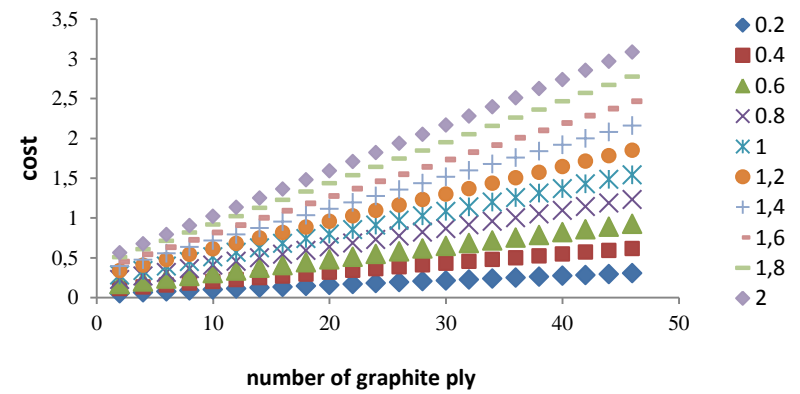
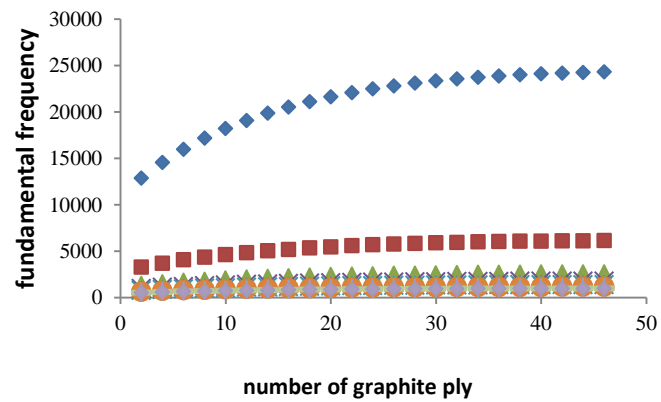
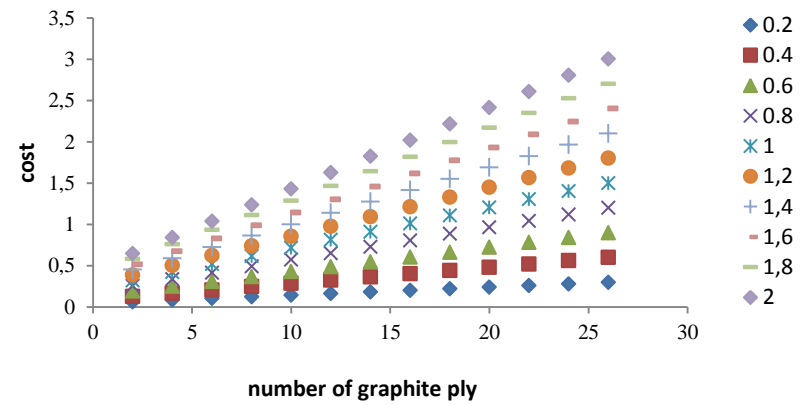
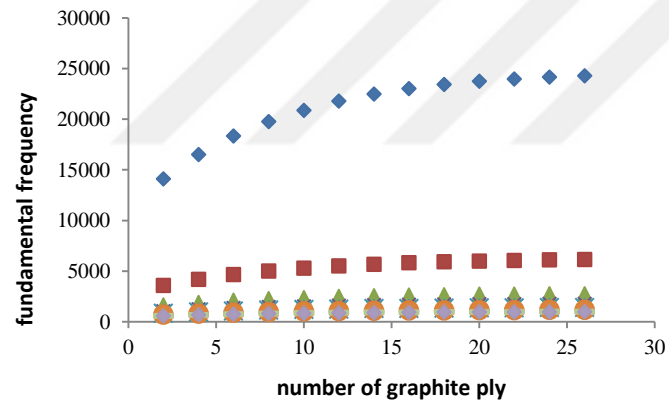

**Figure 6.1 :** fundamental frequency and cost of laminated composite for 28 and 48 ply depends on aspect ratio and number of graphite ply



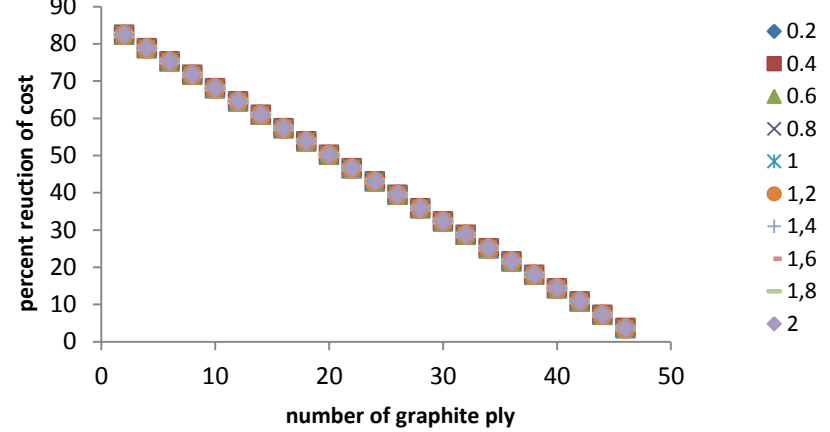
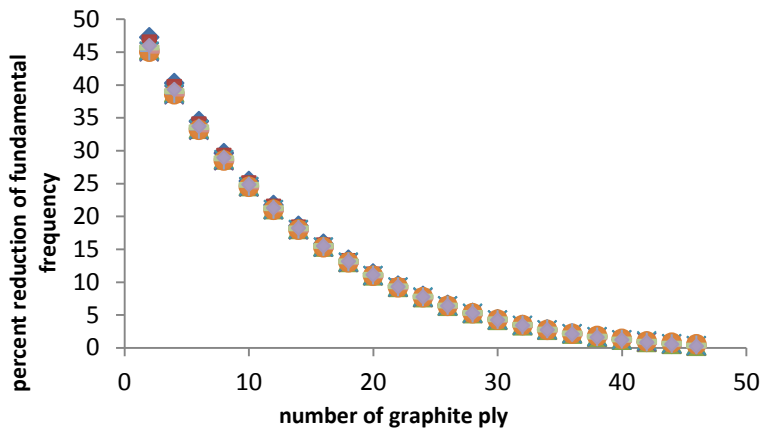
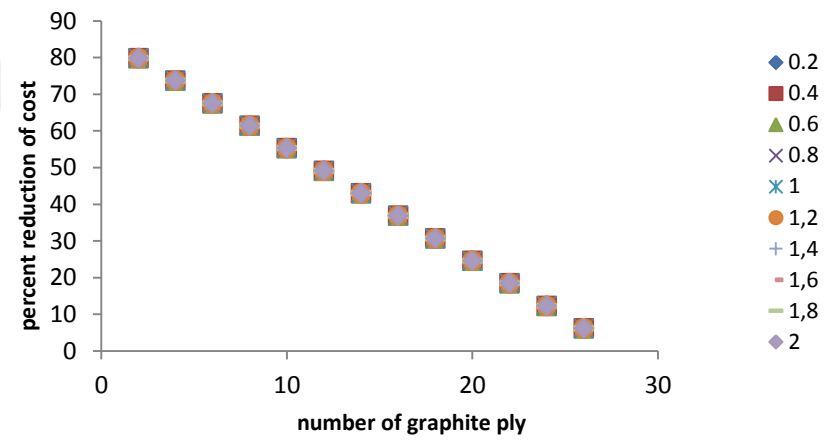
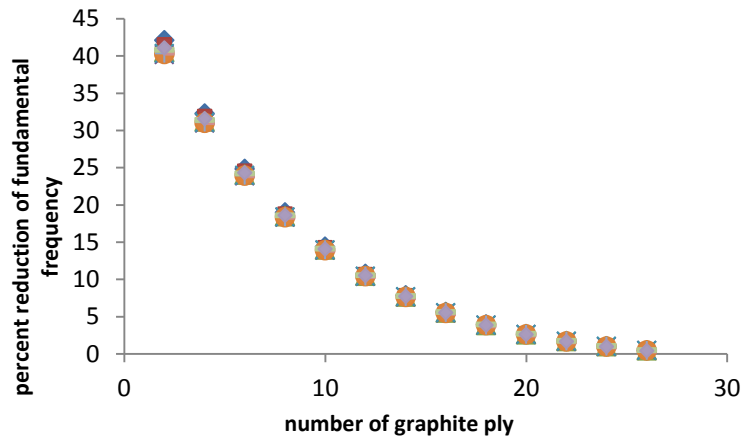

Figure 6.2 : percent reduction of fundamental frequency and cost of laminated composite for 28 and 48 ply depends on aspect ratio and number of graphite ply

## Chapter 7

### STOCHASTIC OPTIMIZATION OF GRAPHITE-FLAX/EPOXY INTERPLY HYBRID LAMINATED COMPOSITE FOR MAXIMUM FUNDAMENTAL FREQUENCY AND MINIMUM COST

In chapter 6, the stacking sequence optimization of graphite-glass/epoxy interply hybrid laminated composite plates have been conducted based on multi objective approach. Traditional fiber reinforcement composite materials generally have consisted of glass, carbon and /or combination of these. In addition to being strong and rigid, when these materials are mixed, they save up price and weight. However, in recent years, automobile, aircraft and construction industries focus on eco-friendly materials including cheaper, lightweight and high mechanical properties (Prabhakaran, 2014). Flax fiber is one of the natural fibers having high specific strength and low density and they can be used as alternative to glass fiber in a composite system.

In this chapter, in order to see the performance of flax fillers in the interply hybrid composite structures, graphite-flax/epoxy hybrid composites are considered instead of graphite-glass/epoxy. The design variables of the optimization problems are selected as fiber orientation angles, the number of outer layers ( $N_o$ ) comprising graphite/epoxy and the number of inner layers ( $N_i$ ) comprising flax/epoxy.

As mentioned previous chapter, a function  $F$  is introduced to maximize frequency and minimize cost simultaneously. Because graphite/epoxy is about twenty times more expensive than flax/epoxy, comparative cost ratio is taken as 20. ( $\alpha_0=20$ )

In order to evaluate performance of graphite-flax/epoxy hybrid structure concerning fundamental frequency and cost are solved two different problems. The results based on stochastic optimization algorithms DE, NM and SA have been compared to results given in Abachizadeh and Tahani (2009) by ACO.

### **Problem 13**

Organization of the problem is similar to problem 8 such that multi objective optimization in order to maximize fundamental frequency and minimize cost including various aspect ratios of the laminated plates. However, in order to see the performance of flax fillers in the interply hybrid composite structures, 8-layered symmetric graphite-flax/epoxy hybrid composites are considered instead of graphite-glass/epoxy. Fiber orientation angles of the layers are considered in the range of -90 and 90 with 15 degree increments. The stochastic optimization methods DE, NM and SA are used.

### **Problem 14**

The problem is just an extension of Problem 13 for 28-layered symmetric graphite-flax/epoxy hybrid composites and deal with various aspect ratios by using the stochastic optimization method DE, NM, SA.

The optimum stacking sequence designs of 8-layered graphite-flax/epoxy symmetric hybrid composite for minimum index  $F$  (Problem 13), fundamental frequency and cost are given in Table 7.1. The graphite-flax/epoxy composite the fundamental frequency and cost values vary between 855.85 - 20887.70 and 0.0898 - 0.8983, respectively. The mean of  $F$  values is calculated as 0.09844. The comparison of present results and those of the results by Abachizadeh and Tahani (2009) for 8-layered symmetric graphite-flax/epoxy and graphite-glass/epoxy hybrid composites shows that the usage of flax fiber instead of glass fiber in hybrid laminates increases the fundamental frequency by approximately 8.5% and decreases the material cost by 21%. Furthermore, it is shown that the parameter  $F$  reduces 42.5%.

**Table 7.1** : Comparison of optimum stacking sequences design in terms of index F and corresponding values on fundamental frequencies and cost for 8-layered symmetric hybrid graphite-flax/epoxy laminates with  $15^0$  increment

a/b	Stacking sequence				$N_0$	$\omega$ (rad/s)				Cost			F		
	ACO <sup>1</sup>	DE (Present)	NM (Present)	SA (Present)		ACO <sup>1</sup>	DE (Present)	NM (Present)	SA (Present)	ACO <sup>1</sup>	DE/NM SA	ACO <sup>1</sup>	DE	NM	SA
0.2	$[0]_{4s}$	$[0]_{4s}$	$[0/-15/0_2]_s$	$[0]_{4s}$	2	19093	20887.70	20832.80	20887.70	0.1138	0.0898	0.1732	0.0994	0.1001	0.0994
0.4	$[0]_{4s}$	$[0]_{4s}$	$[0]_{4s}$	$[0]_{4s}$	2	4844	5293.05	5293.05	5293.05	0.2275	0.1797	0.1725	0.0990	0.0989	0.0990
0.6	$[15/0_3]_s$	$[-15/0_3]_s$	$[\pm 15/0_2]_s$	$[-15/0_2/15]_s$	2	2210	2410.01	2409.88	2410	0.3413	0.2695	0.1707	0.0983	0.0983	0.0983
0.8	$[\pm 30]_{2s}$	$[-30]_{4s}$	$[-30_3/30]_s$	$[-30_4]_s$	2	1421	1547.84	1547.84	1547.84	0.4550	0.3593	0.1708	0.0980	0.0972	0.0980
1	$[\pm 45]_{2s}$	$[-45_2/\pm 45]_s$	$[-45_2/45/15]_s$	$[-45/45_3]_s$	2	1116	1216.44	1215.96	1216.44	0.5687	0.4491	0.1705	0.0981	0.0982	0.0981
1.2	$[\pm 45]_{2s}$	$[-45_2/\pm 45]_s$	$[-45_2/45/30]_s$	$[\mp 45/\pm 45]_s$	2	940	1023.89	1023.66	1023.89	0.6825	0.5390	0.1706	0.0981	0.0982	0.0981
1.4	$[\pm 60]_{2s}$	$[-60]_{4s}$	$[-60_2/60/30]_s$	$[\mp 60/\pm 60]_s$	2	851	927.93	927.57	927.93	0.7963	0.6288	0.1705	0.0981	0.0982	0.0981
1.6	$[\pm 75]_{2s}$	$[-75]_{4s}$	$[-75_2/75_2]_s$	$[-75_2/75_2]_s$	2	802	874.78	874.78	874.78	0.9100	0.7186	0.1709	0.0982	0.0981	0.0982
1.8	$[90]_{4s}$	$[90]_{4s}$	$[90]_{4s}$	$[90]_{4s}$	2	790	861.88	861.88	861.88	1.0238	0.8084	0.1714	0.0985	0.0985	0.0985
2	$[90]_{4s}$	$[90]_{4s}$	$[90/-30/90/-30]_s$	$[90]_{4s}$	2	784	855.85	842.59	855.85	1.1375	0.8983	0.1720	0.0987	0.1026	0.0987

<sup>1</sup>(Abachizadeh and Tahani, 2009)

**Table 7.2 :** Comparison of optimum stacking sequences design in terms of index F and corresponding values on fundamental frequencies and cost for 28-layered symmetric hybrid graphite-flax/epoxy laminates with  $15^0$  increment

a/b	Stacking sequence				No
	ACO <sup>1</sup>	DE (Present)	NM (Present)	SA (Present)	
0.2	[0] <sub>14s</sub>	[0] <sub>14s</sub>	[0 <sub>3</sub> / -15 / 0 / ±15 / 0 / -30 / 0 / -15 <sub>2</sub> / ±15] <sub>s</sub>	[0 <sub>3</sub> / -30 <sub>2</sub> / -15 / 60 / 30 / 90 / 0 / -15 / 90 / -75 / 45] <sub>s</sub>	6
0.4	[0] <sub>14s</sub>	[0] <sub>14s</sub>	[0 <sub>3</sub> / -15 <sub>2</sub> / 0 <sub>2</sub> / 15 / -30 / 0 / -15 <sub>2</sub> / ±15] <sub>s</sub>	[0 <sub>3</sub> / -15 / 30 / 0 / 60 / 90 / 15 / -45 / -60 / 90 / -30 / -15] <sub>s</sub>	6
0.6	[15 <sub>3</sub> / 0 <sub>11</sub> ] <sub>s</sub>	[±15 / 15 / 0 <sub>9</sub> / -15 / 0] <sub>s</sub>	[-15 <sub>3</sub> / 0 <sub>2</sub> / 15 <sub>3</sub> / -15 / 0 / -15 <sub>2</sub> / 15 / 0] <sub>s</sub>	[-15 <sub>2</sub> / 0 / ±15 <sub>2</sub> / -15 / 30 / 90 / -30 / -15 / 30 <sub>2</sub> ] <sub>s</sub>	6
0.8	[±30] <sub>7s</sub>	[-30 <sub>2</sub> / 30 / -45 / -30 <sub>2</sub> / ±30 / -30 <sub>2</sub> / 45 / -60 / 90 <sub>2</sub> ] <sub>s</sub>	[-30 / ±30 / 15 / 30 / 45 / 30 / 0 / -45 / 15 / -45 / -30 / 0 / 30] <sub>s</sub>	[-45 / 30 / ∓45 / -45 / ∓30 / 45 / -30 <sub>2</sub> / -45 / 15 / 60 / -45] <sub>s</sub>	6
1	[±45] <sub>7s</sub>	[-45 <sub>4</sub> / 45 <sub>2</sub> / ∓45 / 30 / 60 / -15 / -60 / ±15] <sub>s</sub>	[-45 <sub>2</sub> / ±45 / 0 / 15 / ∓45 / -15 / -30 / 0 / 15 / 45 / 60] <sub>s</sub>	[-45 <sub>2</sub> / 45 / -30 / -45 / 45 <sub>2</sub> / -60 / -30 / 60 / 45 / -75 <sub>3</sub> ] <sub>s</sub>	6
1.2	[±45] <sub>7s</sub>	[∓45 / -45 <sub>2</sub> / 60 <sub>2</sub> / -45 / -75 / 45 <sub>4</sub> / 30 / 60] <sub>s</sub>	[±45 / 45 / -30 / 45 / -30 / -45 / 15 / -45 <sub>2</sub> / -30 <sub>2</sub> / 0 / 60] <sub>s</sub>	[-45 / 45 <sub>4</sub> / -45 <sub>2</sub> / 90 / 75 / -60 / 90 <sub>2</sub> / -75 / 30] <sub>s</sub>	6
1.4	[±60] <sub>7s</sub>	[60 / -60 <sub>5</sub> / 60 <sub>2</sub> / 90 <sub>2</sub> / -45 / 90 <sub>2</sub> / 60] <sub>s</sub>	[±60 / 60 / -15 / 45 / -60 <sub>2</sub> / 45 / -60 / 90 / 15 / -30 / 0 / 75] <sub>s</sub>	[∓60 <sub>2</sub> / ±60 / 60 / -75 / 30 / ∓60 / -45 <sub>2</sub> / 60] <sub>s</sub>	6
1.6	[±75] <sub>7s</sub>	[-75 <sub>2</sub> / 75 <sub>2</sub> / -75 / 90 / 75 <sub>2</sub> / 90 / -75 / 90 <sub>4</sub> ] <sub>s</sub>	[-75 <sub>3</sub> / ±75 / -75 / 75 <sub>5</sub> / -60 / ∓15] <sub>s</sub>	[75 <sub>3</sub> / -60 / 90 <sub>2</sub> / 60 / 90 / -75 / 90 <sub>2</sub> / ∓45 / 15] <sub>s</sub>	6
1.8	[90] <sub>14s</sub>	[90] <sub>14s</sub>	[90 <sub>10</sub> / 75 / 90 / -60 <sub>2</sub> ] <sub>s</sub>	[90 <sub>4</sub> / -75 / 90 / -75 / 90 <sub>2</sub> / -60 / 90 <sub>3</sub> / -45] <sub>s</sub>	6
2	[90] <sub>14s</sub>	[90] <sub>14s</sub>	[90 <sub>4</sub> / -75 <sub>2</sub> / 90 <sub>4</sub> / ±75 / -45 / 60] <sub>s</sub>	[90 <sub>5</sub> / -75 / 90 <sub>4</sub> / 30 / 90 / 0 / 15] <sub>s</sub>	6

<sup>1</sup> (Abachizadeh and Tahani, 2009)

**Table 7.2 (cont.) :** Comparison of optimum stacking sequences design in terms of index F and corresponding values on fundamental frequencies and cost for 28-layered symmetric hybrid graphite-flax/epoxy laminates with 15<sup>0</sup> increment

a/b	$\omega$ (rad/s)				Cost		F			
	ACO <sup>1</sup>	DE (Present)	NM (Present)	SA (Present)	ACO <sup>1</sup>	DE NM/SA	ACO <sup>1</sup>	DE (Present)	NM (Present)	SA (Present)
0.2	18339	20038.50	19960.90	19666.10	0.1039	0.0788	0.1667	0.0926	0.0937	0.0982
0.4	4656	5080.08	5067.54	5011.09	0.2079	0.1577	0.1657	0.0919	0.0925	0.0960
0.6	2127	2314.79	2314.68	2310.19	0.3118	0.2366	0.1632	0.0909	0.0908	0.0914
0.8	1368	1486.44	1483.62	1484.15	0.4157	0.3155	0.1631	0.0906	0.0902	0.0911
1	1074	1167.36	1159.66	1165.86	0.5196	0.3943	0.1629	0.0910	0.0929	0.0913
1.2	905	982.85	978.16	981.90	0.6236	0.4732	0.1630	0.0908	0.0922	0.0911
1.4	820	890.87	884.03	890.37	0.7275	0.5521	0.1629	0.0908	0.0931	0.0910
1.6	772	840.20	840.12	839.68	0.8314	0.6309	0.1633	0.0908	0.0907	0.0910
1.8	760	827.67	827.63	827.29	0.9354	0.7098	0.1641	0.0911	0.0912	0.0913
2	754	821.70	821.08	820.69	1.0393	0.7886	0.1649	0.0915	0.0917	0.0918

<sup>1</sup>(Abachizadeh and Tahani, 2009)

Table 7.2 shows the optimum stacking sequence designs of 28-layered symmetric graphite-flax/epoxy hybrid composites in terms of index F (Problem 14) and corresponding values on fundamental frequency and cost. The graphite-flax/epoxy composite, the fundamental frequency and cost values change between 821.70 - 20038.50 and 0.0788 - 0.7886, respectively. The mean of F values is also calculated as 0.09844. The comparison of present results and those of the results by Abachizadeh and Tahani (2009) for 28-layered symmetric graphite-flax/epoxy and graphite-glass/epoxy hybrid composites shows the usage of flax fiber increases the fundamental frequency by 8.5% , decreases the material cost by 24%. Moreover, It is shown that the parameter F decreases 41%.

In addition to obtained hybrid graphite-flax/epoxy fundamental frequency and cost results, regarding the results given in Tables 7.1, 7.2 and 5.2, it can be inferred that the usage of interply hybrid graphite-flax/epoxy laminated structures decrease the fundamental frequency by 14% and cost by 71.9% for 8-layered while decrease fundamental frequency by 17.5% and cost by 75.4% for 28-layered composites.

## CHAPTER 8

### CONCLUSION

In this thesis, the optimum designs of non-hybrid and hybrid laminated composite plates have been investigated. In non-hybrid case, fundamental frequency is taken as objective function and fiber angles of the laminated composites are taken as discrete design variables. The optimization has been conducted using graphite/epoxy, glass/epoxy and flax/epoxy materials for various aspect ratios (0.2-2). Single-objective optimization formulation have been used for mathematical verification of model problems. In hybrid cases, multi objective approach is considered to maximize the fundamental frequency and minimize the cost simultaneously. The design variables of the optimization problems are selected as fiber angles, the number of outer layers ( $N_o$ ) having high-stiffness and more expensive and the number of inner layers ( $N_i$ ) having low-stiffness and inexpensive. The optimization has been conducted using hybrid graphite-glass/epoxy and graphite-flax/epoxy materials for various aspect ratios (0.2-2). A stochastic search techniques Differential Evolution (DE), Nelder Mead (NM), Random Search (RS) and Simulated Annealing (SA) have been considered as an optimization method. MATHEMATICA COMMERCIAL SOFTWARE have been utilized in optimization process.

In order to obtain optimum design in terms of fundamental frequency and cost, non-hybrid and hybrid cases deal with step by step. Firstly, frequency performance of laminated composite determines using graphite/epoxy, glass/epoxy and flax/epoxy materials. The results given in Tables show that graphite/epoxy provides higher fundamental frequency than glass/epoxy and flax/epoxy. However, graphite/epoxy material is eight times more expensive than glass/epoxy and twenty times more expensive than flax/epoxy. It should be noted that cost is a crucial factor for all the engineering problems and therefore, it has to be taken into account in the design an optimization problems of the laminated composite materials. In this regard,



designers utilize hybridization process to reduce cost and weight of laminated composite as well as providing safer design. For these reasons, secondly, hybrid structure including graphite/epoxy in outer layers and glass/epoxy in inner layers are considered so as to supply high frequency and low cost simultaneously. The results presented in Tables indicate that hybridization concept can reduce cost as well as keep the frequency at reasonable level. On the other hand, in recent years, ecological approach in automotive, aerospace and marine industries have stated that natural fibers (especially flax) are used as alternative reinforcing materials to glass fibers because of their inherent good vibration and cost performances. In this regard, finally, in order to provide maximum fundamental frequency and minimum cost, the usage of flax fiber as an alternative to E-glass in hybrid composite structures are considered. It can be clearly seen from the results given in Tables that (i) the fundamental frequency performance of graphite–flax/epoxy laminated composite is approximately 8.5% higher than those of graphite–glass/epoxy and (ii) the cost of graphite–flax/epoxy is 21-24% less than graphite–glass/epoxy ones. Furthermore, it is shown that the parameter  $F$  reduces 40-42.5%.

Finally, It can be concluded that

- (1) If fundamental frequency is considered as an objective function, the results regarding graphite fiber give the higher values comparing glass and flax fiber ones. If cost and weight is considered as an objective function, flax fiber can be selected as material.
- (2) By using interply hybrid composite structures, it is possible to design laminated composite with high fundamental frequency and low cost without sacrificing in stiffness-to-weight ratios. In this regard, it is shown that the potential usage of graphite–flax/epoxy hybrid composite material instead of graphite-glass/epoxy is appropriate.
- (3) The different stochastic optimization algorithms DE, NM, RS and SA have been performed for the same laminated composite design problems, successfully. Thus, this attempt has improved reliability and robustness of the process and also provided to avoid inherent scattering of the stochastic algorithms.
- (4) In non hybrid case, the results obtained by DE, NM, RS and SA are compared to results obtained by ACO (Abachizadeh and Tahani, 2009) and GA (Karakaya and

Soykasap, 2011). According the results, DE, NM, RS and SA indicate comperable performance in terms of fundamental frequency.

(5) In hybrid case, the results obtained by DE, NM and SA are compared to results obtained by GA (Tahani et al., 2005) and SA (Kolahan et al., 2005). According the results, DE, NM and SA indicate superior performance in terms of fundamental frequency.

(6) The results based on stochastic optimization algorithms DE, NM and SA have been compared to results given in Abachizadeh and Tahani (2009) by ACO method for the same laminated composite structure design and optimization problems. Regarding the results, DE, NM and SA show superior or at least comparable performance to obtain (i) the maximum fundamental frequency, (ii) the minimum cost and (iii) minimum index F.

(7) According to the results, it is suggested that the flax fiber has potential to be viable candidate for applications which need of high fundamental frequency with low cost and weight.

## REFERENCES

- Abachizadeh, M., & Tahani, M. (2007). Ant colony optimization of hybrid laminates for minimum cost and weight. In D. Saravanos (Ed.), *Proceedings of 6th international symposium on advanced composites COMP'07*. Greece.
- Abachizadeh, M., & Tahani, M. (2009). An ant colony optimization approach to multi-objective optimal design of symmetric hybrid laminates for maximum fundamental frequency and minimum cost. *Structural and Multidisciplinary Optimization*, 37(4), 367–376. <https://doi.org/10.1007/s00158-008-0235-6>
- Adali, S., & Duffy, K. (1992). Minimum cost design of vibrating laminates by hybridization. *Engineering Optimization*, 19(4), 255–267. <https://doi.org/10.1080/03052159208941231>
- Adali, S., & Verijenko, V. E. (2001). Optimum stacking sequence design of symmetric hybrid laminates undergoing free vibrations. *Composite Structures*, 54(2–3), 131–138. [https://doi.org/10.1016/S0263-8223\(01\)00080-0](https://doi.org/10.1016/S0263-8223(01)00080-0)
- Akbulut, M., & Sonmez, F. O. (2008). Optimum design of composite laminates for minimum thickness. *Computers & Structures*, 86(21–22), 1974–1982. <https://doi.org/10.1016/j.compstruc.2008.05.003>
- Ameri, E., Aghdam, M. M., & Shakeri, M. (2012). Global optimization of laminated cylindrical panels based on fundamental natural frequency. *Composite Structures*, 94(9), 2697–2705. <https://doi.org/10.1016/j.compstruct.2012.04.005>
- Apalak, M. K., Yildirim, M., & Ekici, R. (2008). Layer optimisation for maximum fundamental frequency of laminated composite plates for different edge conditions. *Composites Science and Technology*, 68(2), 537–550. <https://doi.org/10.1016/j.compscitech.2007.06.031>
- Aydin, L. (2011). *Design of dimensionally-stable laminated somposites subjected to hygro-thermo-mechanical loading by stochastic optimization methods*. Izmir Institute of Technology. <http://openaccess.iyte.edu.tr/handle/11147/3170>
- Aydin, L., & Artem, H. S. (2011). Comparison of stochastic search optimization algorithms for the laminated composites under mechanical and hygrothermal loadings. *Journal of Reinforced Plastics and Composites*, 30(14), 1197–1212.

<https://doi.org/10.1177/0731684411415138>

- Aydin, L., Aydin, O., Artem, H. S., & Mert, A. (2016). Design of dimensionally stable composites using efficient global optimization method. *Proceedings of the Institution of Mechanical Engineers, Part L: Journal of Materials: Design and Applications*, 1464420716664921.  
<https://doi.org/10.1177/1464420716664921>
- Aydin, L., Karaca Ugural, B., & Ozdogan, E. (2015). Design of dimensionally stable flax/polypropylene composite plates by using stochastic optimization. In *4th International Polymeric Composites Symposium & Exhibition and Brokerage Event*. Izmir-Turkey.
- Baier, H., Huber, M., & Langer, H. (2008). Design optimization of hybrid material structures. *Structural and Multidisciplinary Optimization*, 36(2), 203–213.  
<https://doi.org/10.1007/s00158-007-0204-5>
- Barati, R. (2011). Parameter Estimation of Nonlinear Muskingum Models Using Nelder-Mead Simplex Algorithm. *Journal of Hydrologic Engineering*, 19(NOVEMBER), 1–8. [https://doi.org/10.1061/\(ASCE\)HE](https://doi.org/10.1061/(ASCE)HE)
- Beluch, W., Burczynski, T., & Dlugosz, A. (2007). Evolutionary multi-objective optimization. *Comput Assis Mech Eng Sci*, 14(4), 569–578.  
[https://www.researchgate.net/profile/Witold\\_Beluch/publication/259328531](https://www.researchgate.net/profile/Witold_Beluch/publication/259328531)
- Bert, C. W. (1977). Optimal design of a composite-material plate to maximize its fundamental frequency. *Journal of Sound and Vibration*, 50(2), 229–237.  
[https://doi.org/10.1016/0022-460X\(77\)90357-1](https://doi.org/10.1016/0022-460X(77)90357-1)
- Bintag, (2011). Boeing 787/7E7, [www.bintang.sitell.com/Boeing\\_787/Boeing\\_787\\_files/Specifications.html](http://www.bintang.sitell.com/Boeing_787/Boeing_787_files/Specifications.html)
- Blevins, R. D. (1979). 212225572-Blevins-Formulas-for-Natural-Frequency-and-Mode-Shape.pdf. New York: Van Nostrand Reinhold.
- Bos, H. L. (2004). *The potential of flax fibres as reinforcement for composite materials*. <https://doi.org/10.6100/IR575360>
- Bressan, F., Bona, F. De, & Somà, A. (2004). Design of composite laminates with low thermal expansion. *Proceedings of the Institution of Mechanical Engineers, Part L: Journal of Materials: Design and Applications*, 218(3), 201–209.  
<https://doi.org/10.1177/146442070421800304>
- Callahan, K. J., & Weeks, G. E. (1992). Optimum design of composite laminates using genetic algorithms. *Composites Engineering*, 2(3), 149–160.

[https://doi.org/10.1016/0961-9526\(92\)90001-M](https://doi.org/10.1016/0961-9526(92)90001-M)

- Carus, M. (2011). Bio-composites: technologies, applications and markets. In In: 4th International conference on sustainable materials, polymers and composites. Birmingham, UK.
- Civalek, Ö. (2008). Free vibration analysis of symmetrically laminated composite plates with first-order shear deformation theory (FSDT) by discrete singular convolution method. *Finite Elements in Analysis and Design*, 44(12–13), 725–731. <https://doi.org/10.1016/j.finel.2008.04.001>
- Daniel, I. M., & Ishai, O. (2005). *Engineering Mechanics of Composite Materials*. <https://doi.org/10.1016/B978-0-08-006421-5.50049-6>
- Dean C., K. (1963). Random search techniques for optimization problems. *Automatica*, 1(2–3), 111–121. [https://doi.org/10.1016/0005-1098\(63\)90018-9](https://doi.org/10.1016/0005-1098(63)90018-9)
- Dittenber, D. B., & Gangarao, H. V. S. (2012). Critical review of recent publications on use of natural composites in infrastructure. *Composites Part A: Applied Science and Manufacturing*. <https://doi.org/10.1016/j.compositesa.2011.11.019>
- Duc, F., Bourban, P. E., & Manson, J. E. (2014). The role of twist and crimp on the vibration behaviour of flax fibre composites. *Composites Science And Technology*, 102, 94–99. <https://doi.org/10.1016/j.compscitech.2014.07.004>
- Duffy, K., & Adali, S. (1991). Maximum frequency design of prestressed symmetric, cross-ply laminates of hybrid construction. *Adv Des Autom*, 2, 477–484.
- Erdal, O., & Sonmez, F. O. (2005). Optimum design of composite laminates for maximum buckling load capacity using simulated annealing. *Composite Structures*, 71(1), 45–52. <https://doi.org/10.1016/j.compstruct.2004.09.008>
- Fan, S.-K. S., Liang, Y.-C., & Zahara, E. (2006). A Genetic Algorithm and a Particle Swarm Optimizer Hybridized with Nelder-Mead Simplex Search.pdf. *Computers and Industrial Engineering*, 401–425.
- Fang, C., & Springer, G. S. (1993). Design of composite laminates by a Monte Carlo method. *Journal of Composite Materials*, 27, 721–753. <https://doi.org/10.1177/002199839302700705>
- Faruk, O., Bledzki, A. K., Fink, H. P., & Sain, M. (2012). Biocomposites reinforced with natural fibers: 2000-2010. *Progress in Polymer Science*. <https://doi.org/10.1016/j.progpolymsci.2012.04.003>
- Fukunaga, H., Sekine, H., & Sato, M. (1994). Optimal Design of Symmetric Laminated Plates for Fundamental Frequency. *Journal of Sound and Vibration*.

<https://doi.org/10.1006/jsvi.1994.1115>

- Ghasemi, M., & Ehsani, A. (2007). Multi objective optimization of composite laminates under heat and moisture effects using a hybrid neuro GA algorithm. *International Journal of Civil, Environmental, Structural, Construction and Architectural Engineering*, 1.
- Grenestedt, J. L. (1989). Layup optimization and sensitivity analysis of the fundamental eigenfrequency of composite plates. *Composite Structures*, 12(3), 193–209. [https://doi.org/10.1016/0263-8223\(89\)90022-6](https://doi.org/10.1016/0263-8223(89)90022-6)
- Groenwold, A. A., & Haftka, R. T. (2006). Optimization with non-homogeneous failure criteria like Tsai--Wu for composite laminates. *Structural and Multidisciplinary Optimization*, 32(3), 183–190. <https://doi.org/10.1007/s00158-006-0020-3>
- Grosset, L., Venkataraman, S., & Haftka, R. (2001). Genetic optimization of two-material composite laminates. In *16th ASC technical meeting*. Blacksburg-Virginia.
- Gubran, H. B. H., & Gupta, K. (2002). Composite Shaft Optimization Using Simulated Annealing, Part I: Natural Frequency. *International Journal of Rotating Machinery*, 8(4), 275–283. <https://doi.org/10.1155/S1023621X02000258>
- Gurdal, Z., Haftka, R. T., & Hajela, P. (1999). *Design and optimization of laminated composite materials*. John Wiley & Sons.
- Hasancebi, O., Carbas, S., Dogan, E., Erdal, F., & Saka, M. P. (2010). Comparison of non-deterministic search techniques in the optimum design of real size steel frames. *Computers and Structures*, 88(17–18), 1033–1048. <https://doi.org/10.1016/j.compstruc.2010.06.006>
- Hemmatian, H., Fereidoon, A., Sadollah, A., & Bahreininejad, A. (2013). Optimization of laminate stacking sequence for minimizing weight and cost using elitist ant system optimization. *Advances in Engineering Software*, 57, 8–18. <https://doi.org/10.1016/j.advengsoft.2012.11.005>
- Ho-Huu, V., Do-Thi, T. D., Dang-Trung, H., Vo-Duy, T., & Nguyen-Thoi, T. (2016). Optimization of laminated composite plates for maximizing buckling load using improved differential evolution and smoothed finite element method. *Composite Structures*, 146, 132–147. <https://doi.org/10.1016/j.compstruct.2016.03.016>

- Irisarri, F. X., Bassir, D. H., Carrere, N., & Maire, J. F. (2009). Multiobjective stacking sequence optimization for laminated composite structures. *Composites Science and Technology*, 69(7–8), 983–990.  
<https://doi.org/10.1016/j.compscitech.2009.01.011>
- Karakaya, S., & Soykasap, O. (2009). Buckling optimization of laminated composite plates using genetic algorithm and generalized pattern search algorithm. *Structural and Multidisciplinary Optimization*, 39(5), 477.  
<https://doi.org/10.1007/s00158-008-0344-2>
- Karakaya, S., & Soykasap, O. (2011). Natural frequency and buckling optimization of laminated hybrid composite plates using genetic algorithm and simulated annealing. *Structural and Multidisciplinary Optimization*, 43, 61–72.  
<https://doi.org/10.1007/s00158-010-0538-2>
- Kaw, A. K. (2006). Mechanics of composite materials 2nd. Optics Express (Vol. 18). Retrieved from <http://www.ncbi.nlm.nih.gov/pubmed/20725652>
- Khdeir, A. A., & Reddy, J. N. (1999). Free vibrations of laminated composite plates using second-order shear deformation theory. *Computers & Structures*, 71(6), 617–626. [https://doi.org/10.1016/S0045-7949\(98\)00301-0](https://doi.org/10.1016/S0045-7949(98)00301-0)
- Kolahan, F., Tahani, M., & Sarhadi, A. (2005). Optimal design of sandwich composite laminates for minimum cost and maximum frequency using simulated annealing. In Sadeghi (Ed.), *Proceedings of Tehran international conference on manufacturing engineering TICME*. Tahrán-Iran.
- Lakshmi, K., & Rao, A. R. M. (2015). Optimal design of laminate composite plates using dynamic hybrid adaptive harmony search algorithm. *Journal of Reinforced Plastics and Composites*, 34(6), 493–518.  
<https://doi.org/10.1177/0731684415574228>
- Le Riche, R., & Gaudin, J. (1998). Design of dimensionally stable composites by evolutionary optimization. *Composite Structures*, 41(2), 97–111.  
[https://doi.org/10.1016/S0263-8223\(98\)00009-9](https://doi.org/10.1016/S0263-8223(98)00009-9)
- Le Riche, R., & Haftka, R. T. (1992). Optimization of laminated stacking sequence for buckling load maximization by genetic algorithm. *Aiaa*, 31(5), 951–956.  
<https://doi.org/10.2514/3.11710>
- Liang, S., Gning, P.-B., & Guillaumat, L. (2015). Quasi-static behaviour and damage assessment of flax/epoxy composites. *Materials & Design*, 67, 344–353.

<https://doi.org/10.1016/j.matdes.2014.11.048>

- Liang, S., Gning, P. B., & Guillaumat, L. (2012). A comparative study of fatigue behaviour of flax / epoxy and glass / epoxy composites. *Composites Science and Technology*, 72(5), 535–543. <https://doi.org/10.1016/j.compscitech.2012.01.011>
- Liang, S., Guillaumat, L., & Gning, P.-B. (2015). Impact behaviour of flax/epoxy composite plates. *International Journal of Impact Engineering*, 80, 56–64. <https://doi.org/10.1016/j.ijimpeng.2015.01.006>
- Lopez, R. H., Luersen, M. A., & Cursi, E. S. (2009). Optimization of laminated composites considering different failure criteria. *Composites Part B: Engineering*, 40(8), 731–740. <https://doi.org/10.1016/j.compositesb.2009.05.007>
- Mallick, P. (2007). Fiber-reinforced composites: materials, manufacturing, and design. Taylor & Francis Group, LLC.
- Manoharan, S., & Shanmuganathan, S. (1999). Comparison of search mechanisms for structural optimization. *Computers and Structures*, 73(1–5), 363–372. [https://doi.org/10.1016/S0045-7949\(98\)00287-9](https://doi.org/10.1016/S0045-7949(98)00287-9)
- Meirovitch, L. (1986). Elements of Vibration Analysis. [https://doi.org/10.1016/S0022-460X\(87\)80083-4](https://doi.org/10.1016/S0022-460X(87)80083-4)
- Narita, Y., & Leissa, A. W. (1992). Frequencies and mode shapes of cantilevered laminated composite plates. *Journal of Sound and Vibration*, 154(1), 161–172. [https://doi.org/10.1016/0022-460X\(92\)90410-Y](https://doi.org/10.1016/0022-460X(92)90410-Y)
- Narita, Y. (2003). Layerwise optimization for the maximum fundamental frequency of laminated composite plates. *Journal of Sound and Vibration*, 263(5), 1005–1016. [https://doi.org/10.1016/S0022-460X\(03\)00270-0](https://doi.org/10.1016/S0022-460X(03)00270-0)
- Narita, Y. (2006). Maximum frequency design of laminated plates with mixed boundary conditions. *International Journal of Solids and Structures*, 43(14–15), 4342–4356. <https://doi.org/10.1016/j.ijsolstr.2005.06.104>
- Nelder, J. A., & Mead, R. (1965). A simplex-method for function minimization. *Computer Journal*, 7(4), 308–313. <https://doi.org/10.1093/comjnl/7.4.308>
- Nemeth, M. (1986). Importance of anisotropy on buckling of compression-loaded symmetric composite plates. *AIAA J*, 24, 1831–1835.
- Ngo-Cong, D., Mai-Duy, N., Karunasena, W., & Tran-Cong, T. (2011). Free vibration analysis of laminated composite plates based on FSDT using one-dimensional IRBFN method. *Computers & Structures*, 89(1–2), 1–13.



<https://doi.org/10.1016/j.compstruc.2010.07.012>

- Nguyen, H. X., Duy Hien, T., Lee, J., & Nguyen-Xuan, H. (2017). Stochastic buckling behaviour of laminated composite structures with uncertain material properties. *Aerospace Science and Technology*, 66, 274–283.  
<https://doi.org/10.1016/j.ast.2017.01.028>
- Pelletier, J. L., & Vel, S. S. (2006). Multi-objective optimization of fiber reinforced composite laminates for strength, stiffness and minimal mass. *Computers and Structures*, 84(29–30), 2065–2080.  
<https://doi.org/10.1016/j.compstruc.2006.06.001>
- Pham, D., & Karaboga, D. (2000). *Intelligent optimisation techniques, genetic algorithms, tabu search, simulated annealing and neural network*. Springer, New York. <https://doi.org/10.1007/978-1-4471-0721-7>
- Prabhakaran, S., Krishnaraj, V., Senthil Kumar, M., & Zitoune, R. (2014). Sound and vibration damping properties of flax fiber reinforced composites. In *Procedia Engineering* (Vol. 97, pp. 573–581).  
<https://doi.org/10.1016/j.proeng.2014.12.285>
- Qatu, M. S. (1991). Free vibration of laminated composite rectangular plates. *International Journal of Solids and Structures*, 28(8), 941–954.  
[https://doi.org/10.1016/0020-7683\(91\)90122-V](https://doi.org/10.1016/0020-7683(91)90122-V)
- Rao, A. R. M., & Lakshmi, K. (2011). Discrete hybrid PSO algorithm for design of laminate composites with multiple objectives. *Journal of Reinforced Plastics and Composites*, 30(20), 1703–1727.  
<https://doi.org/10.1177/0731684411417198>
- Rao, S. S. (2009). *Engineering Optimization: Theory and Practice*. Wiley.  
<https://doi.org/10.1002/9780470549124>
- Reddy, J. (2004). *Mechanics of laminated composite plates and shells: theory and analysis* (2nd edn). Boca Raton- FL: CRC.
- Reiss, R., & Ramachandran, S. (1987). Maximum Frequency Design of Symmetric Angle-ply Laminates. In I. H. Marshall (Ed.), *Composite Structures 4: Volume 1 Analysis and Design Studies* (pp. 476–487). Dordrecht: Springer Netherlands.  
[https://doi.org/10.1007/978-94-009-3455-9\\_37](https://doi.org/10.1007/978-94-009-3455-9_37)
- Roque, C. M. C., & Martins, P. A. L. S. (2015). Differential evolution optimization for the analysis of composite plates with radial basis collocation meshless method. *Composite Structures*, 124, 317–326.

<https://doi.org/10.1016/j.compstruct.2015.01.019>

Roque, C. M. C., & Martins, P. A. L. S. (2017). Maximization of fundamental frequency of layered composites using differential evolution optimization. *Composite Structures*. <https://doi.org/10.1016/j.compstruct.2017.01.037>

Shah, D. U., Schubel, P. J., Licence, P., & Clifford, M. J. (2012).

Hydroxyethylcellulose surface treatment of natural fibres: the new “twist” in yarn preparation and optimization for composites applicability. *Journal of Materials Science*, 47(6), 2700–2711. <https://doi.org/10.1007/s10853-011-6096-1>

Shah, D. U., Schubel, P. J., & Clifford, M. J. (2013). Can flax replace E-glass in structural composites? A small wind turbine blade case study. *Composites Part B: Engineering*, 52, 172–181.

<https://doi.org/10.1016/j.compositesb.2013.04.027>

Sivanandam, S. N., & Deepa, S. N. (2008). *Introduction to Genetic Algorithms*. *Introduction to Genetic Algorithms*. Berlin, Heidelberg: Springer Berlin Heidelberg. <https://doi.org/10.1007/978-3-540-73190-0>

Soremekun, G., Gürdal, Z., Haftka, R. T., & Watson, L. T. (2001). Composite laminate design optimization by genetic algorithm with generalized elitist selection. *Computers & Structures*, 79(2), 131–143.

[https://doi.org/10.1016/S0045-7949\(00\)00125-5](https://doi.org/10.1016/S0045-7949(00)00125-5)

Soykasap, O., & Karakaya, S. (2007). Structural Optimization of Laminated Composite Plates for Maximum Buckling Load Capacity Using Genetic Algorithm. In *Advances in Fracture and Damage Mechanics VI* (Vol. 348, pp. 725–728). Trans Tech Publications.

<https://doi.org/10.4028/www.scientific.net/KEM.348-349.725>

Spallino, R., & Rizzo, S. (2002). Multi-objective discrete optimization of laminated structures. *Mechanics Research Communications*, 29(1), 17–25.

[https://doi.org/10.1016/S0093-6413\(02\)00227-6](https://doi.org/10.1016/S0093-6413(02)00227-6)

Storn, R., & Price, K. (1997). Differential Evolution – A Simple and Efficient Heuristic for global Optimization over Continuous Spaces. *Journal of Global Optimization*, 11(4), 341–359. <https://doi.org/10.1023/A:1008202821328>

Tahani, M., Kolahan, F., & Sarhadi, A. (2005). Genetic algorithm for multi-objective optimal design of sandwich composite laminates with minimum cost and maximum frequency. In N. Radhakrishnan & J. Sankar (Eds.), *Proceedings of international conference on advances in materials, product design and*

- manufacturing systems ICMPM* (pp. 741–748). India.
- Topal, U. (2012). Frequency optimization for laminated composite plates using extended layerwise approach. *Steel and Composite Structures*, 12(6), 541–548.
- Topal, U., & Uzman, Ü. (2008). Frequency optimization of laminated composite angle-ply plates with circular hole. *Materials & Design*, 29(8), 1512–1517. <https://doi.org/10.1016/j.matdes.2008.03.002>
- Tsai, S., & Hahn, H. (1980). *Introduction to composite materials*. Connecticut: Wesport Technomic Publishing Company.
- Vinson, J. R., & Sierakowski, R. L. (2004). *The Behavior of Structures Composed of Composite Materials*. Kluwer Academic Publishers.
- Vo-Duy, T., Ho-Huu, V., Do-Thi, T. D., Dang-Trung, H., & Nguyen-Thoi, T. (2017). A global numerical approach for lightweight design optimization of laminated composite plates subjected to frequency constraints. *Composite Structures*, 159, 646–655. <https://doi.org/10.1016/j.compstruct.2016.09.059>
- Walker, M., Reiss, T., & Adali, S. (1998). Optimal design of symmetrically laminated plates for minimum deflection and weight. *Composite Structures*, 39, 337–346. [https://doi.org/10.1016/S0263-8223\(97\)00109-8](https://doi.org/10.1016/S0263-8223(97)00109-8)
- Wambua, P., Ivens, J., & Verpoest, I. (2003). Natural fibres: Can they replace glass in fibre reinforced plastics? *Composites Science and Technology*, 63(9), 1259–1264. [https://doi.org/10.1016/S0266-3538\(03\)00096-4](https://doi.org/10.1016/S0266-3538(03)00096-4)
- Yan, L., Chouw, N., & Jayaraman, K. (2014). Flax fibre and its composites - A review. *Composites Part B: Engineering*, 56, 296–317. <https://doi.org/10.1016/j.compositesb.2013.08.014>
- Zabinsky, Z. B. (2011). Random Search Algorithms. In *Wiley Encyclopedia of Operations Research and Management Science*, 1–16. <https://doi.org/10.1002/9780470400531.eorms0704>
- Zhang, Y., Li, Y., Ma, H., & Yu, T. (2013). Tensile and interfacial properties of unidirectional flax / glass fiber reinforced hybrid composites. *Composites Science and Technology*, 88, 172–177. <https://doi.org/10.1016/j.compscitech.2013.08.037>

## VITA

Melih SAVRAN

10-09-1991, İzmir/TURKEY

### **EDUCATION**

- M.Sc. (2014-2017)** : Mechanical Engineering, İzmir Katip Çelebi University  
**P.S. (2013-2014)** : Preparation School (English), İzmir Katip Çelebi University  
**B.Sc (2009-2013)** : Mechanical Engineering, Celal Bayar University

### **SCI JOURNAL PAPERS**

- Yurekli Y, Yildirim M, Aydın L, Savran M, Filtration and removal performances of membrane adsorbers, *Journal of Hazardous Materials*, Volume:332 Pages 33-41, 2017.
- Savran M, Aydın L, Stochastic optimization of graphite-flax/epoxy hybrid laminated composite for maximum fundamental frequency and minimum cost. *Journal Of Sound And Vibration* (Under Review)
- Savran M, Aydın L, Artem H.S, Stochastic optimization of graphite-glass/epoxy hybrid laminated composite for maximum fundamental frequency and minimum cost (will be submitted )

### **INTERNATIONAL PEER-REVIEWED JOURNAL PAPERS**

- Aydın L, Artem H.S, Savran M, Stokastik optimizasyon metotları kullanılarak boyutsal kararlı uydu ve havacılık malzemelerinin geliştirilmesi, *Afyon Kocatepe Üniversitesi Fen ve Mühendislik Bilimleri Dergisi* (Under Review)

### **INTERNATIONAL CONFERENCE PROCEEDINGS**

- Savran M, Aydın L, Optimum design of hybrid graphite-glass/epoxy laminated composite for minimum cost and maximum frequency using a stochastic optimization method, 5th INTERNATIONAL POLYMERIC COMPOSITES SYMPOSIUM AND WORKSHOPS (2017)

### **PROJECT**

- Complete Removal of Urea by Using Polymer/Inorganic/Urease Bio-Composite Membrane (TUBİTAK-1001, 2014-2016)