

**AUGUST 2018**

**Ph.D. in Civil Engineering**

**RENAS SHERKO**

**HASAN KALYONCU UNIVERSITY  
GRADUATE SCHOOL OF  
NATURAL & APPLIED SCIENCES**

**A BIM BASED DESIGN OPTIMIZATION FRAMEWORK FOR THE ENERGY  
EFFICIENT BUILDING DESIGN IN TURKEY**

**Ph.D. THESIS  
IN  
CIVIL ENGINEERING**

**BY  
RENAS SHERKO  
AUGUST 2018**

**A BIM Based Design Optimization Framework for the Energy Efficient  
Building Design in Turkey**

**Ph.D. Thesis**

**in**

**Civil Engineering**

**Hasan Kalyoncu University**

**Supervisor**

**Prof. Dr. Yusuf ARAYICI**

**by**

**Renas SHERKO**

**August 2018**

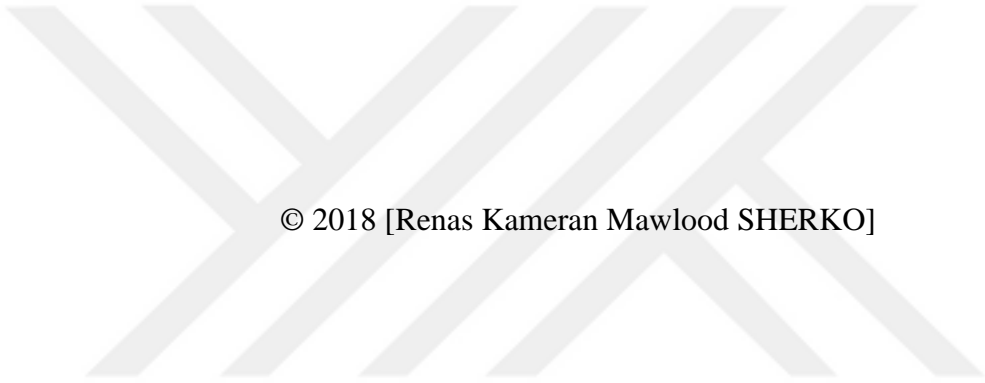

© 2018 [Renas Kameran Mawlood SHERKO]



**GRADUATE SCHOOL OF NATURAL &  
APPLIED SCIENCES INSTITUTE  
PhD ACCEPTANCE AND APPROVAL FORM**

Civil Engineering Department, Civil Engineering PhD (Philosophy of Doctorate) programme student **Renan Kameran Mawlood SHERKO** prepared and submitted the thesis titled **"A BIM Based Design Optimization Framework for the Energy Efficient Building Design in Turkey"** defended successfully at the VIVA on the date of 14/8/2018 and accepted by the jury as a PhD thesis.

<u>Position</u>	<u>Title, Name and Surname</u> <u>Department/University</u>	<u>Signature</u>
PhD Supervisor	Prof. Dr. Yusuf ARAYICI Civil Engineering Department/ Hasan Kalyoncu University	
Chair of the PhD VIVA Board	Prof. Dr. Yusuf ARAYICI Civil Engineering Department/ Hasan Kalyoncu University	
Jury Member	Prof. Dr. Mustafa GÜNAL Civil Engineering Department/ Gaziantep University	
Jury Member	Prof. Dr. Hanifi ÇANAKÇI Civil Engineering Department/ Gaziantep University	
Jury Member	Prof. Dr. Ömer ARIÖZ Civil Engineering Department/ Hasan Kalyoncu University	
Jury Member	Prof. Dr. Mehmet KARPUZCU Civil Engineering Department/ Hasan Kalyoncu University	

This thesis is accepted by the jury members selected by the institute management board and approved by the institute management board.

Prof. Dr. Mehmet KARPUZCU  
Director

**I hereby declare that all information in this document has been obtained and presented in accordance with academic rules and ethical conduct. I also declare that, as required by these rules and conduct, I have fully cited and referenced all materials and results that are not original to this work.**

Renas SHERKO

## ABSTRACT

### **A BIM BASED DESIGN OPTIMIZATION FRAMEWORK FOR THE ENERGY EFFICIENT BUILDING DESIGN IN TURKEY**

SHERKO, Renas Kameran Mawlood  
Ph.D. in Civil Engineering  
Supervisor: Prof. Dr. Yusuf ARAYICI  
August 2018, 235 pages

Buildings in Turkey consume a great amount of energy to supply comfort conditions. This is due to the in-effective design decision made by designers with no considerations of environmental impact and energy assessment. That's why, building design parameters should be studied and examined during the design stage considering the environment, which is a crucial factor that suggests enough information to develop well-suited building design. The application of renewable energy such as PV (photovoltaic) technology can be another solution which in turn may lead to better energy performance and fewer CO<sub>2</sub> emission. BIM as a new way of working methodology enables energy efficient design solutions considering design parameters for the improved high building performance in Turkey. Thus, the aim of this research is to develop a strategic BIM framework for optimized design process, technology implementation, building design rules considering the local values and energy assessment of the factors influencing the concept design for the energy efficient buildings in Turkey. Research adopts multi case study methodology that helps to gain qualitative and quantitative insights and understanding current practices. Revit based BIM modelling is used with Design Builder software for energy performance simulation in relation to the building design parameters. The outcome will be a design guide for the optimised building design in Turkey. This design guide will help designers for the successful use of BIM for the design optimization process, effective technology implementation, rules-based design development and energy assessment scheme reflecting the local values for the sustainable building design.

**Keywords:** Building information modelling (BIM), BIM framework, Design builder, Energy consumption, Energy efficiency, Revit architecture.

## ÖZET

### TÜRKİYE'DE ENERJİ VERİMLİ BİNALAR TASARIMI İÇİN BİM BAZLI TASARIM OPTİMİZASYON ÇERÇEVESİ

SHERKO, Renas Kameran Mawlood  
Doktora Tezi, İnşaat Mühendisliği Bölümü  
Danışman: Prof. Dr. Yusuf ARAYICI  
Ağustos 2018, 235 sayfa

Türkiye'deki binalar konfor şartlarını sağlamak için çok fazla enerji harcarlar. Bu, tasarımcılar tarafından yapılan ve çevresel etki ve enerji değerlendirmesine dair herhangi bir düşünceye sahip olmayan etkili tasarım kararından kaynaklanmaktadır. Bu nedenle, tasarım parametrelerinin, tasarım aşaması boyunca, uygun bina tasarımını geliştirmek için yeterli bilgiyi öneren önemli bir faktör olan çevre göz önünde bulundurularak çalışılması ve incelenmesi gerekir. PV (fotovoltaik) teknolojisi gibi yenilenebilir enerjinin uygulanması, daha iyi bir enerji performansına ve daha az CO<sub>2</sub> emisyonuna neden olabilecek bir başka çözüm olabilir. Yeni bir çalışma olarak BIM, Türkiye'de yüksek bina performansı için tasarım parametrelerini göz önünde bulundurarak enerji verimli tasarım çözümleri sağlamaktadır. Bu nedenle, bu araştırmanın amacı, Türkiye'de enerji verimli binalar için konsept tasarımını etkileyen faktörlerin yerel değerleri ve enerji değerlendirmesini dikkate alarak optimize edilmiş tasarım süreci, teknoloji uygulaması, bina tasarımı kuralları için stratejik bir BIM çerçevesi geliştirmektir. Araştırma, nitel ve nicel içgörüler kazanmaya ve mevcut uygulamaları anlamalarına yardımcı olan çoklu vaka çalışmaları metodolojisini benimsemiştir. Sonuç, Türkiye'de optimize edilmiş bina tasarımı için bir tasarım rehberi olacaktır. Bu tasarım kılavuzu, tasarımcıların tasarım optimizasyon süreci, etkin teknoloji uygulaması, kurallara dayalı tasarım geliştirme ve sürdürülebilir bina tasarımı için yerel değerleri yansıtan enerji değerlendirme planı için BIM'in başarılı bir şekilde kullanılmasına yardımcı olacaktır.

**Anahtar Kelimeler:** Bina bilgi modelleme (BIM), BIM çerçevesi, Tasarım oluşturucu, Enerji tüketimi, Enerji verimliliği, Revit mimarisi.

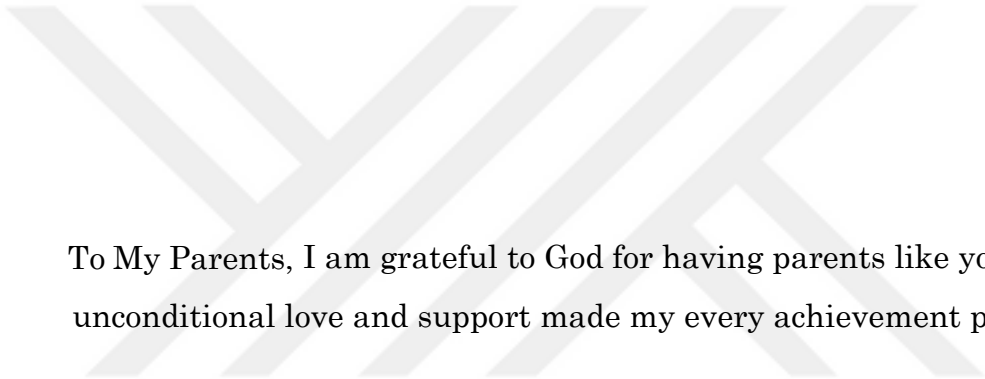

To My Parents, I am grateful to God for having parents like you. Your unconditional love and support made my every achievement possible.



## **ACKNOWLEDGEMENTS**

Firstly, I am so thankful to the Almighty God for giving me this opportunity. May the Almighty grant me the wisdom and ability to appreciate the limitless bounties showered upon me.

I would like to show my deepest gratefulness to my supervisor Professor Yusuf Arayici. He has generously provided his invaluable insights, inspiring ideas, constant guidance, and warm encouragement. His advices and guidance have been invaluable in shaping this research.

I would also like to show my full appreciation to my parents, sisters for their unlimited love, prayers, support and cooperation throughout the work on this research.

Warm gratitude goes to everyone who has made my thesis to be completed successfully. I also want to thank everyone who has contributed from far and close to the realization of this study.

## TABLE OF CONTENTS

	<b>Page</b>
ABSTRACT.....	v
ÖZET.....	vi
ACKNOWLEDGEMENTS.....	viii
TABLE OF CONTENTS.....	ix
LIST OF TABLES.....	xv
LIST OF FIGURES.....	xviii
LIST OF SYMBOLS/ABBREVIATIONS.....	xix
CHAPTER 1.....	1
INTRODUCTION.....	1
1.1. Introduction.....	1
1.2. Background of the Study.....	2
1.3. Rationale of Research.....	4
1.4. Research Questions.....	5
1.5. Research Aim and Objectives.....	6
1.6. Research Methodology.....	7
1.6.1. Research philosophy.....	7
1.6.2. Research approach.....	7
1.6.3. Research strategy.....	7
1.6.4. Research choices.....	8
1.6.5. Time horizons.....	8
1.6.6. Technique and procedure.....	8
1.7. Scope and Limitations of the Research.....	8
1.8. Ethical Issues.....	9
1.9. Contribution to the Knowledge.....	9
1.10. Guide to Thesis.....	10
CHAPTER 2.....	12
LITERATURE REVIEW.....	12
2.1. Energy Use in Buildings.....	12
2.2. Energy Performance and Energy Efficiency Features of Buildings in Turkey.....	15
2.3. Components to be Considered in the Building Design for Energy Efficiency.....	17
2.3.1. Climate features and building location.....	17
2.3.2. Building architecture and orientation.....	18
2.3.3. Building envelopes.....	19
2.3.3.1. Walls.....	21
2.3.3.2. Roofs.....	22
2.3.3.3. Insulation.....	22
2.3.3.4. Windows.....	24
2.3.3.5. Shading.....	25
2.3.4. Renewable energy practices.....	26

2.3.4.1. Solar energy photovoltaic (PV) technology .....	27
2.3.4.2. Solar energy practices in Turkey.....	29
2.3.4.3. Buildings integrated photovoltaic (BIPV) system applications ....	30
2.4. Previous Studies.....	33
2.5. Conclusion .....	36
CHAPTER 3 .....	37
BUILDING INFORMATION MODELLING AS A NEW WAY OF SUPPORTING SUSTAINABLE BUILDINGS DESIGN .....	37
3.1. BIM Definition .....	37
3.2. The Importance of BIM .....	38
3.3. The Employment of Building Information Modelling (BIM) in Construction .....	41
3.4. Barriers to the Adoption of Building Information Modelling (BIM) .....	42
3.5. Building Information Modelling (BIM) and Sustainability.....	44
3.5.1. Economical sustainability .....	45
3.5.2. Environmental sustainability.....	46
3.5.3. Social sustainability .....	46
3.6. Energy Performance Simulation.....	47
3.6.1. BIM for improving building energy performance .....	48
3.6.2. Interoperability between BIM and energy simulation software.....	49
3.6.3. Traditional design method vs performance based design method .....	50
3.7. Autodesk Revit as a Building information modelling (BIM) tool.....	51
3.7.1. Autodesk Revit (BIM) advantages.....	52
3.7.2. Autodesk Revit (BIM) disadvantages .....	53
3.8. Energy Simulation Software Tools.....	54
3.8.1. Energy Plus .....	56
3.8.2. Autodesk Ecotect .....	56
3.8.3. Autodesk Green Building Studio .....	58
3.8.4. Integrated Environmental Solutions – Virtual Environment (VE) .....	59
3.8.5. E-Quest.....	60
3.8.6. Design Builder .....	61
3.9. Conclusion .....	63
CHAPTER 4 .....	64
RESEARCH METHODOLOGY AND DESIGN .....	64
4.1. Research Methodology .....	64
4.1.1. Research philosophy .....	65
4.1.2. Research approach .....	68
4.1.2.1. Deduction .....	68
4.1.2.2. Induction .....	69
4.1.3. Research strategy .....	69
4.1.3.1. Experiment .....	70
4.1.3.2. Survey .....	70
4.1.3.3. Case study .....	70
4.1.3.4. Action research.....	71
4.1.3.5. Grounded theory.....	71
4.1.3.6. Ethnography .....	72
4.1.3.7. Archival research .....	72
4.1.4. Research choice.....	72
4.1.4.1. Quantitative research.....	72
4.1.4.2. Qualitative research.....	72

4.1.4.3. Multiple methods .....	73
4.1.5. Time horizons.....	73
4.1.6. Technique and procedure .....	74
4.2. Research Design .....	74
4.2.1. Research philosophy .....	75
4.2.2. Research approach .....	76
4.2.3. Research strategy .....	76
4.2.4. Research choice.....	76
4.2.5. Time horizons.....	77
4.2.6. Technique and procedure .....	77
4.2.6.1. Defining and designing .....	78
4.2.6.2. Preparing, collecting, and analyzing .....	79
4.2.6.3. Analysis and conclusion.....	80
CHAPTER 5 .....	81
PERFORMANCE BASED DESIGN THROUGH INTEGRATED BIM USE: A RESIDENTIAL BUILDING CASE STUDY .....	81
5.1. Rationale of Using Revit Architecture and Design Builder Software for the Simulation Process.....	81
5.2. Case Study Description.....	82
5.2.1. Model development.....	83
5.2.2. Preparation of energy model .....	85
5.2.2.1. Assigning location and weather data.....	85
5.2.2.2. Construction materials used in the actual building design.....	86
5.2.2.3. Lighting system used in the actual building design .....	87
5.2.2.4. HVAC system used for the actual building design .....	88
5.2.3. Parameters Studied.....	88
5.2.3.1. Building orientation .....	89
5.2.3.2. External walls.....	89
5.2.3.3. Wall insulation .....	90
5.2.3.4. Glazing .....	90
5.3. Analysis and Results .....	91
5.3.1. The impact of orientation on building energy consumption .....	91
5.3.2. The Impact of wall materials on building energy consumption.....	93
5.3.3. The impact of insulation on building energy consumption.....	93
5.3.4. The impact of glazing type on building energy consumption.....	94
5.4. Case Study Findings .....	95
5.5. The Initial BIM Based Design and Optimization Framework.....	96
5.5.1. Hypothetical BIM based design optimization framework to be implemented.....	97
5.5.1.1. A design optimization process .....	98
5.5.1.2. Technology implementation (PV technology) .....	99
5.5.1.3. Design ontology and rules reflecting local values .....	100
5.5.1.4. Local energy performance assessment scheme.....	102
5.6. Conclusion .....	103
CHAPTER 6 .....	104
BUILDING DESIGN OPTIMIZATION PROCESS AND TECHNOLOGY IMPLEMENTATION .....	104
6.1. ARBIM Building Case Study .....	104
6.1.1. Model development and building description.....	106
6.1.2. Energy model preparation .....	106

6.1.3. Information exchange (data exporting process).....	108
6.1.4. Information exchange (data importing process) .....	109
6.1.5. Energy model preparation in Design Builder software.....	111
6.1.5.1. Building location and orientation.....	111
6.1.5.2. The properties of building materials .....	111
6.1.6. ARBIM building analysis and results .....	113
6.1.6.1. Actual building energy performance analysis and results.....	113
6.1.6.2. Performance values as environmental indicators.....	114
6.1.6.3. The impact of building orientation on building energy performance .....	114
6.1.6.4. The impact of glazing on building energy performance .....	118
6.1.6.5. The impact of wall insulation on building energy performance .	122
6.1.6.6. Combination of optimum results- best practices.....	124
6.2. The Design Optimization Process Components .....	125
6.2.1. Stakeholders .....	126
6.2.2. Process stages and tasks .....	126
6.2.3. Data and information exchange requirements.....	128
6.3. Technology Implementation: PV Technology.....	130
6.3.1. Modelling solar photovoltaic (PV) system by using Design Builder software.....	131
6.3.1.1. Geometric model development of solar PV module and array ...	131
6.3.1.2. Assigning electrical performance model to the solar PV array...	133
6.3.1.3. Creation of (PV) electrical performance model.....	134
6.3.1.4. Including electrical load center to the model (dc-to-ac) inverter equipment.....	135
6.3.2. Calculating the annual energy consumption of the building.....	135
6.3.3. Calculating the annual electricity generated by PV System .....	136
6.3.4. Results .....	136
6.3.4.1. The impact of PV array orientation on total electricity generation .....	136
6.3.4.2. The impact of PV tilt angle on total electricity generation .....	137
6.3.4.3. The impact of PV row distance on total electricity generation...	138
6.4. Conclusion .....	138
<b>CHAPTER 7 .....</b>	<b>141</b>
<b>BUILDING DESIGN RULES AND LOCAL ENERGY ASSESSMENT SECHEME REFLECTING LOCAL VALUES .....</b>	<b>141</b>
7.1. Ecological Building Design Criteria and Strategies .....	142
7.2. Ecological Building Case Study .....	144
7.2.1. Building location and properties .....	146
7.2.2. The properties of building materials .....	146
7.2.3. The actual building energy consumption .....	147
7.2.4. Energy conservation criteria .....	148
7.2.4.1. Effective direction of the building .....	148
7.2.4.2. Design of simple geometric form.....	149
7.2.4.3. Green roof application.....	151
7.2.4.4. Proper Use of photovoltaic (PV) panels.....	154
7.2.5. Material Conservation Criteria.....	155
7.2.5.1. Preventing heat loss by choosing proper insulation materials ....	155
7.2.5.2. High performance window.....	157
7.2.5.3. Appropriate wall materials selection.....	159

7.2.5.4. Effective window shading design .....	160
7.3. Building Design Rules Reflecting Local Values .....	162
7.4. Building Design Evaluation (Local Energy Performance Assessment Scheme) .....	164
7.4.1. Green building certificate schemes .....	164
7.4.1.1. LEED scheme.....	165
7.4.1.2. BRERAM scheme .....	165
7.4.1.3. Green star scheme .....	165
7.4.2. A local energy performance assessment scheme .....	166
7.5. Conclusion .....	170
CHAPTER 8 .....	171
THE OVERALL BIM BASED DESIGN FRAMEWORK.....	171
8.1. Introduction.....	171
8.2. Enhancement of the Implemented BIM Framework .....	172
8.2.1. Component 1: a design optimization process.....	173
8.2.2. Component 2: technology implementation (PV technology) .....	175
8.2.3. Component 3: design rules and ontology.....	176
8.2.4. Component 4: local energy performance assessment scheme .....	178
8.3. The Overall BIM Based Design Optimization Framework .....	180
8.4. Conclusion .....	183
CHAPTER 9 .....	185
THE VALIDATION OF THE OVERALL BIM BASED DESIGN AND OPTIMIZATION FRAMEWORK .....	185
9.1. The Building Design Process (Health Center Building) Case Study.....	185
9.1.1. Building location and orientation.....	187
9.1.2. The properties of the building materials .....	187
9.1.3. The actual building energy performance.....	188
9.2. Building Design Optimization .....	189
9.2.1. Building orientation .....	189
9.2.2. Building form .....	190
9.2.3. PV technology .....	190
9.2.4. Insulation material.....	192
9.2.5. Building external windows .....	194
9.2.6. External walls.....	197
9.2.7. Window shading .....	198
9.3. Optimum Design Decision- Best Practices.....	200
9.4. Building Design Evaluation and Assessment .....	201
9.5. Suggestions to Optimize Building Energy Performance .....	205
9.6. Conclusion .....	207
CHAPTER 10 .....	209
CONCLUSION AND RECOMMENDATION .....	209
10.1. Introduction.....	209
10.2. Achievement of Objectives.....	210
10.2.1. Objective 1 .....	210
10.2.2. Objective 2 .....	211
10.2.3. Objective 3 .....	211
10.2.4. Objective 4 .....	211
10.2.5. Objective 5 .....	212
10.2.6. Objective 6 .....	213
10.2.7. Objective 7 .....	213

10.3. Contributions to the Knowledge .....	213
10.4. Main Conclusions from the Research .....	214
10.5. Recommendations for Future Work .....	216
REFERENCES.....	218
CURRICULUM VITAE.....	234



## LIST OF TABLES

	<b>Page</b>
<b>Table 5.1.</b> The physical characteristic of building envelope materials .....	87
<b>Table 5.2.</b> The physical properties of glazing .....	87
<b>Table 5.3.</b> Building lighting type and illuminance values.....	88
<b>Table 5.4.</b> The properties of building wall materials.....	90
<b>Table 5.5.</b> The properties of different insulation materials .....	90
<b>Table 5.6.</b> The physical properties of different glazing types .....	91
<b>Table 5.7.</b> The impact of building orientation on building energy consumption .....	91
<b>Table 5.8.</b> The impact of wall material type on building energy consumption.....	93
<b>Table 5.9.</b> The impact of insulation materials on building energy consumption .....	94
<b>Table 5.10.</b> The impact of glazing type on building energy consumption .....	94
<b>Table 6.1.</b> The physical characteristic of building construction materials .....	112
<b>Table 6.2.</b> The physical properties of the building exterior windows.....	112
<b>Table 6.3.</b> The impact of orientation on building energy consumption .....	115
<b>Table 6.4.</b> The U- values and SHGC values of the simulated glazing types.....	119
<b>Table 6.5.</b> The impact of glazing type on building energy performance .....	119
<b>Table 6.6.</b> The impact of glazing type on annual energy performance and cost.....	121
<b>Table 6.7.</b> The impact of wall insulation on building energy performance .....	122
<b>Table 6.8.</b> The impact of wall insulation on annual energy performance and cost. 124	124
<b>Table 6.9.</b> The annual electricity demand of ARBIM building.....	135
<b>Table 6.10.</b> The PV electricity generation of different PV orientations.....	137
<b>Table 6.11.</b> The PV electricity generation of different PV tilt angles.....	137
<b>Table 6.12.</b> The impact of PV row distance on annual electricity generation.....	138
<b>Table 7.1.</b> Strategies and methods related to ecological building design.....	144
<b>Table 7.2.</b> The physical properties of the actual building construction materials... 146	146
<b>Table 7.3.</b> The physical properties of the building exterior windows.....	147
<b>Table 7.4.</b> The impact of different building orientations on energy performance .. 149	149
<b>Table 7.5.</b> The impact of building shape on building energy performance.....	151



<b>Table 7.6.</b> The impact of plants height on building energy performance.....	153
<b>Table 7.7.</b> The impact of LAI on building energy performance .....	153
<b>Table 7.8.</b> The impact of different roof system on building energy performance...	154
<b>Table 7.9.</b> The impact of wall insulation on building energy performance .....	156
<b>Table 7.10.</b> The impact of roof insulation on building energy performance.....	156
<b>Table 7.11.</b> The impact of window system type on building energy performance .	157
<b>Table 7.12.</b> The impact of window gas gap types on building energy performance .....	158
<b>Table 7.13.</b> The impact of window gap thickness on building energy performance .....	158
<b>Table 7.14.</b> The impact of different wall materials on building energy performance .....	159
<b>Table 7.15.</b> The impact of interior window shading on building energy performance .....	160
<b>Table 7.16.</b> The impact of exterior window shading on building energy performance .....	161
<b>Table 7.17.</b> The impact of interior and exterior window shading on building energy performance.....	162
<b>Table 7.18.</b> Building design rules reflecting local values .....	163
<b>Table 7.19.</b> The evaluation scoring scale legend.....	166
<b>Table 7.20.</b> The local energy assessment scheme .....	167
<b>Table 7.21.</b> Ecological building design evaluation .....	168
<b>Table 8.1.</b> Building Design Rules and Ontology.....	177
<b>Table 8.2.</b> The evaluation scoring scale legend.....	178
<b>Table 8.3.</b> The local energy performance assessment scheme .....	179
<b>Table 8.4.</b> The overall BIM based design optimization framework.....	180
<b>Table 9.1.</b> The physical characteristic of the actual building model .....	187
<b>Table 9.2.</b> The properties of window system used for the building .....	188
<b>Table 9.3.</b> The impact of different building orientation on energy consumption....	189
<b>Table 9.4.</b> The impact of building form on building energy performance .....	190
<b>Table 9.5.</b> The impact of PV orientation on PV efficiency .....	192
<b>Table 9.6.</b> The impact of PV tilt angle on PV efficiency .....	192
<b>Table 9.7.</b> The impact of roof insulation materials on building energy consumption .....	193

<b>Table 9.8.</b> The impact of wall insulation materials on building energy consumption .....	194
<b>Table 9.9.</b> The impacts of window system types on building energy consumption	195
<b>Table 9.10.</b> The impact of glazing types on building energy performance .....	195
<b>Table 9.11.</b> The impact of glazing thickness on building energy performance .....	196
<b>Table 9.12.</b> The impact of window gas types on building energy performance .....	196
<b>Table 9.13.</b> The impact of window gap thickness on building energy performance .....	197
<b>Table 9.14.</b> The impact of wall materials types on building energy performance ..	198
<b>Table 9.15.</b> The impact of internal shading types on building energy performance	199
<b>Table 9.16.</b> The impact of external shading on building energy performance .....	199
<b>Table 9.17.</b> The evaluation scoring scale legend .....	202
<b>Table 9.18.</b> The evaluation of the actual building design .....	203

## LIST OF FIGURES

	<b>Page</b>
<b>Figure 2.1.</b> The breakdown of energy sources of building in Turkey (Kazanasmaz et al., 2014).....	16
<b>Figure 2.2.</b> Different types of solar cells arrangement (Oni and Bolaji, 2011).....	28
<b>Figure 2.3.</b> Different design integration of PV system (Dos Santos and R��ther, 2012) .....	32
<b>Figure 2.4.</b> BIPV arrays are combined with the roof ( Peng et al., 2011).....	32
<b>Figure 2.5.</b> BAPV arrays are attached to the roof ( Peng et al., 2011).....	33
<b>Figure 3.1.</b> The three BIM fields (Succar, 2009) .....	40
<b>Figure 3.2.</b> Sun path analysis in Ecotect (Douglass, 2011).....	57
<b>Figure 3.3.</b> A perspective view of office building in IES (Ayyad, 2011) .....	60
<b>Figure 3.4.</b> An example of two story building in e Quest (Douglass, 2011).....	61
<b>Figure 3.5.</b> An example of residential building geometry shown in design builder (Douglass, 2011) .....	62
<b>Figure 4.1.</b> Research onion methodology (Saunders et al., 2009) .....	65
<b>Figure 4.2.</b> The deductive approach (Creswell, 2014) .....	68
<b>Figure 4.3.</b> The induction approach (Creswell, 2014).....	69
<b>Figure 4.4.</b> Action research process (Saunders et al., 2009) .....	71
<b>Figure 4.5.</b> Research choice (Saunders et al., 2009) .....	73
<b>Figure 4.6.</b> Research design .....	74
<b>Figure 4.7.</b> Case study procedure (Yin, 2014) .....	77
<b>Figure 4.8.</b> Performance-based design (case study) procedure through integrated BIM use.....	79
<b>Figure 5.1.</b> 1st Floor and 2nd Floor of the house building.....	83
<b>Figure 5.2.</b> Building 3D geometry .....	84
<b>Figure 5.3.</b> The exporting process from Revit to gbXML .....	84
<b>Figure 5.4.</b> House building model in design builder .....	85
<b>Figure 5.5.</b> Location template of the actual building model .....	86

<b>Figure 5.6.</b> Building solar radiation rotated every 45 degrees .....	89
<b>Figure 5.7.</b> The initial BIM based Design Optimization Framework .....	97
<b>Figure 6.1.</b> 1 <sup>st</sup> and 2 <sup>nd</sup> floor of ARBIM building.....	105
<b>Figure 6.2.</b> 3D of ARBIM building.....	106
<b>Figure 6.3.</b> Room's area and volume computation setting .....	107
<b>Figure 6.4.</b> Setting the upper bound of rooms.....	108
<b>Figure 6.5.</b> Export setting of gbXML within Revit architecture.....	108
<b>Figure 6.6.</b> The details of correct analytical rooms.....	109
<b>Figure 6.7.</b> A preview of ARBIM building model.....	110
<b>Figure 6.8.</b> Rendered building model in design builder .....	110
<b>Figure 6.9.</b> The monthly heating and cooling energy use for the reference building .....	113
<b>Figure 6.10.</b> The monthly CO <sub>2</sub> emission of the reference building .....	113
<b>Figure 6.11.</b> The heat gain and losses of walls in different directions.....	116
<b>Figure 6.12.</b> Window's solar heat gain at different direction .....	117
<b>Figure 6.13.</b> Heating, cooling energy consumption and CO <sub>2</sub> emission for the actual and optimized building orientation .....	118
<b>Figure 6.14.</b> The impact of actual and optimized window on energy performance	120
<b>Figure 6.15.</b> The impact of (XPS) on annual energy use and CO <sub>2</sub> emission .....	123
<b>Figure 6.16.</b> Building energy performance (best practice).....	125
<b>Figure 6.17.</b> Stakeholders and Design process stages and tasks .....	127
<b>Figure 6.18.</b> Data and information exchange requirements .....	129
<b>Figure 6.19.</b> Exporting data results into excel sheet and importing it into Revit by using Revit excel importer .....	129
<b>Figure 6.20.</b> The physical characteristic of the PV module .....	132
<b>Figure 6.21.</b> Sun path diagram of ARBIM building integrated PV panels .....	133
<b>Figure 6.22.</b> The properties of the PV selected for the building.....	133
<b>Figure 6.23.</b> Electrical specification of poly crystalline PV technology.....	134
<b>Figure 6.24.</b> PV electrical performance model .....	135
<b>Figure 7.1.</b> 3D geometry of ecological building .....	145
<b>Figure 7.2.</b> Building model in design builder.....	145
<b>Figure 7.3.</b> Annual building energy consumption.....	147
<b>Figure 7.4.</b> 100 m <sup>2</sup> square building model .....	150
<b>Figure 7.5.</b> The layers of the green roof.....	152

<b>Figure 7.6.</b> Sparse vegetation on the left, and large vegetation on the right .....	152
<b>Figure 8.1.</b> The initial BIM Based Design Optimization Framework.....	171
<b>Figure 8.2.</b> The main and sub-components, and tasks required for BIM implementation framework .....	172
<b>Figure 8.3.</b> Stakeholders, and process stages and tasks required .....	174
<b>Figure 8.4.</b> Data and information exchange requirements .....	175
<b>Figure 8.5.</b> Design process steps of PV by using design builder .....	176
<b>Figure 9.1.</b> 3D geometry of the health center building model .....	186
<b>Figure 9.2.</b> Building model in design builder.....	186
<b>Figure 9.3.</b> The actual building energy consumption.....	188
<b>Figure 9.4.</b> PV modules attached to the roof of the building .....	191
<b>Figure 9.5.</b> The actual and optimum design energy performance .....	201

## LIST OF SYMBOLS/ABBREVIATIONS

GHG	Greenhouse gas
LCC	Life cycle cost
BIM	Building information modelling
AECO	Architects, engineering, construction, operations
HVAC	Heating ventilation and air conditioning
U-VALUE	Thermal transmittance
WWR	Window to wall ratio
G-VALUE	Total solar energy transmittance
PV	Photovoltaic
BIPV	Building integrated photovoltaic
BAPV	Building attached photovoltaic
SHGC	Solar heat gain coefficient
gbXML	Green building Extensible Markup Language
ICT	Information and communication technology
CAD	Computer aided design
RFI	Requests for information
AIA	American Institute of Architects
BEM	Building energy modelling
ESS	Energy simulation software
IFC	Industry Foundation Class
DS	Design space
MEP	Mechanical, electrical, plumbing
AEC	Architecture, engineering, construction
GBS	Green building studio
DOE	Department of energy
IES	Integrated environmental solutions
EXP	Expanded polystyrene
XPS	Extruded polystyrene

RW	Rock wool
GW	Glass wool
LEED	Leadership in Energy and Environmental Design
BREEAM	Building Research Establishment Environmental Assessment Method
BPS	Building performance simulation
TS	Turkish standard
STC	Standard test condition
NOCT	Nominal operating cell temperature
EC	Energy conservation
MC	Material conservation
LAI	Leaf area index

## CHAPTER 1

### INTRODUCTION

#### 1.1. Introduction

The energy use in buildings has greatly increased over the past decade due to the growth of population, increased time spent inside, more demand for indoor environmental quality and for building functions, and finally global climate change (Cao et al., 2016).

Due to growth of population, economy expansion and the need for improved quality of life, building energy use are expected to continue, fueling the energy demand further. Thus, the increase in energy use will lead to extra greenhouse gas (GHG) emissions with a huge impact on the environment (Harish and Kumar, 2016). Based on these consideration, companies and people need to redefine their activities in a more energy efficient way (Chwieduk, 2016).

As the climate change is getting worse, to eliminate green gas emission, especially carbon emissions, buildings become a top priority of the construction industry. In the meanwhile, higher customer expectations and tighter budgets have carried more pressure on project stakeholders and participants than ever before to control the LCC (life cycle cost). Therefore, techniques and methods which can improve the sustainability of a building while minimizing the LCC have brought more attentions recently. One of the useful methods is developing sustainable buildings (Tao and Tam, 2013).

As evidenced by EU Energy Efficiency Action Plans for 2020 and 2030, the international organizations have placed an extensive effort towards energy efficient buildings recently. Building envelopes which separate the indoor from the outdoor environment, calculate the quantity of energy needed to maintain indoor thermal



comfort. Thus, the best way to save energy in new buildings is to design the building envelope in an energy conscious way (Raji and van den Dobbelseen, 2016).

Building energy consumption can be eliminated by enhancing the thermal performance of the envelopes. The use of phase change materials (PCMs) can greatly reduce overheated hours and shift peak electricity loads, this is due to its important properties in storing and releasing heat within a certain temperature range. Therefore, PCMs is considered as an appropriate and promising solution to increase indoor thermal comfort and reduce the total energy consumed by the building (Han and Taylor, 2016).

Energy saving, which leads to more efficient use of energy without reducing comfort levels, does not only mean rationing or load shedding, rather it means identifying areas of inefficient use of energy and then making quick decisions to eliminate energy waste. To improve building energy efficiency, there are enormous opportunities in place. It is calculated that the energy use of new buildings can be eliminated on an average ranging between (20% and 50%). This can be done by taking and appropriate design decisions regarding building envelopes (Harish and Kumar, 2016).

In general, energy efficiency is an important feature in making building design materials more environmentally friendly. The reason behind using energy efficient material is to less down the quantity of artificially generated power that is brought to the buildings (Jong et al., 2010). Thus, important energy savings can be realized in buildings in case they are appropriately designed, constructed and operated. That's why, efficient energy buildings are considered as a key solution to energy shortages, gas emission and their serious impacts on the environment (Cao et al, 2016). Thus, making effective design decisions at the early design stage is highly required in achieving sustainable building design.

## **1.2. Background of the Study**

Energy conservation as the second most significant signal of energy efficiency is to maximize the energy generation and reduce energy use with the highest efficiency and to decrease energy losses to the lowest level without impacting the standards of living and economic progression. As cited in the definition, the most important issue is to reduce energy use by avoiding energy losses (Yıldız, 2008).

Energy use in buildings can be impacted by many factors, many of them can be fixed and managed to obtain better energy efficiency. The energy performance of the buildings envelope materials including (external walls, roofs, windows etc.) can help in calculating the amount of energy is needed inside the building. Thus, by enhancing building envelopes and insulation, more energy can be saved (Abanda and Byers, 2016).

Enhancing building envelope depends on two approaches: decreasing (U-value) thermal transmittances combined with passive cooling and heating. The (U-value) of envelope materials remarkably impact building energy use by decreasing heat gain or loss partially under harsh environment situations (Cao et al., 2016). Furthermore, the ability that a building must naturally heat or light its indoor may greatly influence energy efficiency and reduces energy use. This is often measured by building orientation (Abanda and Byers, 2016).

Due to the increasing awareness of energy use and the impact of climate on building operations, designers and architects must put more consideration on energy performance and building's sustainability. To ensure that, crucial decisions during the early design stage is highly needed, the use of emerging BIM in building energy simulations has deeply enhanced the process of building energy analysis allowing for superior design decisions and appropriate calculation of buildings performance (Cho et al., 2012).

Presently, Building Information Modelling (BIM) is being used in building design in the Architecture, Engineering, Construction, Operation (AECO) industry by many design firms in their design process. Research in the integration of BIM with building performance tools has been the main focus of both the developers of the BIM authoring tool as well as the building performance simulation community (Young et al., 2008). BIM will be employed soon to completely and virtually create the whole project through simulations even before the construction stage on site. This fact is considered as one of the most important strength of BIM (Froese, 2010).

BIM can help in optimizing building envelope by assessing the heat transferred through envelope materials to reduce energy loads. Furthermore, it can be used to decrease the energy needs and analyze renewable energy options of building before

being constructed. BIM models can be used to determine the impact of orientation on building energy use during the design stage of a project (Abanda and Byers, 2016).

Building Information Modeling (BIM) tools have the ability to provide its users the chance to find out various energy saving alternatives during the early design stages, which in turn will lead to less time consuming process of reentering all the documents related building geometry and other supporting information necessary to complete the energy analysis (Jalaei and Jrade, 2014). Therefore, to ensure high performance buildings, BIM-based energy analysis during early design is highly needed. Because, BIM includes the construction and use of unified and reliable information about a building. Moreover, it leads to make well decisions and appropriate forecast about the building performance (Bahar et al., 2013).

Recently, BIM has become a prevalent method used to achieve sustainable building design. It can be used to simulate any construction project in virtually visible environment. Information related building geometry, quantities and properties of building elements, spatial relationships, and geographical information can be saved in BIM model (Azhar, 2011). As a result, BIM offers the opportunity to simulate building models to verify the performance of different design schemes. Thus, it help designers to enhance their design and choose the most effective one.

### **1.3. Rationale of Research**

One of the most significant problem that need to be underlined and managed by all the people involved and responsible in the construction sector, is the energy saving in the built environment. Thus, designers will be responsible for designing buildings more efficient in term of energy performance, they must seek for a good and in expensive ways to make a good energy saving for buildings. In addition, decreasing heating and cooling energy requirement, which in turn will lead to eliminate CO<sub>2</sub> emission in buildings. Thus, this will play a significant role in the global fight against the current man made phenomena of increasing temperature.

Although energy efficient design strategies are popular and used in building regulations in European countries, they are still not adopted totally in building design as a strategy in Turkey. Bilgiç (2003), took attention to the high energy use of buildings in Turkey, this is because of the lack of insulation standards and energy efficient

designs concern. He also stated that a great amount of energy can be saved if buildings are designed based on the principles of passive design. This statement necessitates to consider building design criteria as they strive towards protecting the nature at the highest possible level and providing the most suitable environment for people within the building (Gür, 2007).

There are numerous studies proved that selecting materials by taking account of climatic conditions results in less energy use and comfortable indoor environment. But nowadays buildings are designed without taking account of environment situation. For example, new buildings in Turkey consume a great amount of energy to supply comfort conditions. This is due to inefficient design (Kocagil and Oral, 2015). This is also supported by Mangan and Oral (2016), who mentioned that the new building design in Turkey does not take into consideration the environmental impact and energy assessment. Moreover, they also declared that the buildings in Turkey just like all over the world are highly responsible for CO<sub>2</sub> emission, this is because of high energy use. Therefore, improving the building energy performance is needed, which in turn will result in a fewer CO<sub>2</sub> emission and energy use. To do that, design parameters should be studied and considered during the design stage about environment, which is a crucial factor that suggests enough information to develop well-suited building design.

For this reason, current practice is leading in optimizing building design for energy efficiency. That is why, strategic BIM use is needed in the concept design in Turkey since there are evidence of successful BIM use for energy efficient building design in other places. Therefore, this research aims to define a strategic BIM guide considering the local values and factors influencing the concept design for energy efficient buildings in Turkey.

#### **1.4. Research Questions**

The main question of the research is “*what is the holistic design approach for the performance-based design and optimization through the BIM use in Turkey?*”

The researcher then will try to answer the following questions:

1. How building design can be optimized to decrease energy consumption by using BIM in the design process.

2. Which design components would better affect the energy performance of a building?
3. How can BIM help for the performance-based design and optimization?
4. What are the active and passive design strategies that would lead to energy efficient buildings?
5. To what degree would the combination of building design strategies provide energy saving?

### **1.5. Research Aim and Objectives**

The main aim of the research is to develop a strategic BIM framework for the optimization of building design for energy efficient buildings in Turkey. Thus, the researcher will try in this dissertation:

1. To explore and identify the important aspects of building energy performance and the challenges and the current architectural trends in Turkey and to explain the components of building design that impacts the energy performance of buildings.
2. To build better understanding about BIM and its implementation in the construction projects, highlighting its importance in achieving sustainable building design.
3. To examine the interoperability between BIM and energy simulation software and specify a simulation system for the analysis of building energy performance considering different design criteria
4. To contextualize a performance-based design framework that takes into consideration of sustainable design requirements.
5. Examine, analyze and compare the energy consumption of two different buildings in terms of varying design strategies adopting the established BIM framework.
6. Enhance the contextualized framework with the findings from the analysis of building design projects by detailing the process, technology, design rules and ontology, and finally the energy assessment scheme perspectives.
7. Validate the performance-based design framework employing BIM on building project and conclude the results with recommendations for the future studies.

## **1.6. Research Methodology**

The research method section briefly introduces research philosophy, research approach and research strategy. However, the research methodology is more fully presented in Chapter 4 under the methodology.

### **1.6.1. Research philosophy**

Research philosophy is an idea or belief about the collection, interpretation and analysis of collected data. However, a variety of philosophies have been explained in Saunders's research onion. These are, positivism, realism, interpretivism and pragmatism (Saunders et al., 2009). In this research, the philosophy adopted is pragmatism, it is not dedicated to any philosophical system, but focuses on the issue and problem to be studied and questions to be asked.

### **1.6.2. Research approach**

The second layer of the onion methodology introduces the research approach. There are two types of research approach, deductive and inductive, each of which will lead to data collection in different ways (Saunders et al., 2009). In this study, the approach used is inductive research approach.

### **1.6.3. Research strategy**

The research strategy is the third layer and most important layer in the Saunders' research onion. It is the plan that the researcher will adopt to answer research questions. There are various types of strategies, such as experiment, survey, action research, case study, grounded theory, ethnography and archival research (Saunders et al., 2009).

In this research the strategy adopted is a case study because the features of this strategy can control all the challenges set by the research questions and objectives. Case study research will enable concentrating on the research questions and allow focusing on the research question and making profound investigations. Furthermore, utilizing a case study in such study, where there is not sufficient knowledge or theories. Moreover, the flexibility that is needed by this study is realized through this strategy because of its ability to deal with different types of questions such as why, what, and how questions and to develop quantitative and qualitative data (Saunders et al, 2009).

#### **1.6.4. Research choices**

The research choice is the fourth layer in the research onion. It can be either quantitative, qualitative or multiple research methods (Saunders et al., 2009). In this research, a mixed method is chosen as a research choice, which means that the data were collected through the use of two methods (qualitative and quantitative) at one time.

#### **1.6.5. Time horizons**

As mentioned by Saunders et al. (2009), there are two types of time horizons, cross sectional and longitudinal research. With the cross sectional time horizon, the data are gathered at one time and these data are studied during a brief time period. With the longitudinal, data are gathered at more than one time, which in turn will lead to understand the changes over time. In this study, the time horizon type adopted by the researcher is the longitudinal time horizon method.

#### **1.6.6. Technique and procedure**

The sixth layer in the research onion is the technique and procedure. In this research, the procedure set by Yin (2014) for a case study is adopted, further explanation is presented in chapter 4.

### **1.7. Scope and Limitations of the Research**

For this research, the scope is the development and validation of a strategic BIM based design and optimization framework for energy efficient buildings in Turkey. Within the framework, we scope on the design and optimization process, the renewable energy technologies such as PV technology, design principles and ontology reflecting local values and environments, and we also identified at local level a performance evaluation and assessment scheme. That's actually represent the dimensions scope for this research. The proposed research includes some limitations, these are as follows:

- 1- In term of the performance simulation of the building models, the analysis was done only for the building design model, the topography in not considered in the analysis and calculation of building design performance.
- 2- Design builder was used for the performance simulation because it is quite comprehensive and accurate and sophisticated system. However, an

assumption was made about some materials of the investigated buildings case studies because these materials are locally manufactured, which are not available in the system. That's why similar materials with different properties were used to design the building model.

- 3- For establishing the design rules related building materials, only those materials were considered and included in the simulation process, which represent the most commonly used materials in Turkey. However, it is likely to be other types of materials, but they are not considered in this research.
- 4- The results of simulation and analysis can only be applied and generalized in Gaziantep-Turkey and other places with similar environmental characteristics.

### **1.8. Ethical Issues**

Ethical issues is defined as the respect for the rights of those being researched, and typically, the obligations that the researcher should do regarding privacy, confidentiality, anonymity and informed consent (Denscombe, 2005). In this research, the researcher sensibly considered all of these principles. In this study, multi case studies buildings were conducted and studied. It is also worth mentioning that a formal letter was submitted to Hasan Kalyoncu University and the municipality of Gaziantep-Turkey to gain access to the buildings and collect building data and information needed for accomplishing the study. As an act of morality, the research considered the confidentiality of information and assurance of data security. The information were only used for this research and nothing else.

### **1.9. Contribution to the Knowledge**

This research will develop an integrated and strategic BIM based design optimization framework for energy efficient building design that enables engineers and designers to search a larger design space more efficiently and provides them with an optimal set of solutions towards higher performance of buildings. Thus, this framework will help designers to successfully use of BIM for design and optimization process, effective technology implementation, rules-based design development and energy assessment scheme reflecting local values for sustainable building design in Turkey.



## **1.10. Guide to Thesis**

This section represent the whole guide and structure to the research just as an preliminary summary of the study that has been done in each chapter, an overview was made to provide a general idea of what each chapter entail.

Chapter 1 introduces the research and explains the backgrounds, rationale for study, the research questions, the research aim and objectives, a brief of the research methodology, and scope of the research.

Chapter 2 deals with the literature related to the topic in a global scale, which includes explaining the important aspects of building energy performance and challenges and the current architectural trends of buildings in Turkey and describes the building design components that impact the energy performance of building.

Chapter 3 deals with the literature related to the topic in a global scale, which addresses a better understanding about BIM and its implementation in the construction industry highlighting its importance in achieving sustainable building design in term of social, economic, and environment sustainability. It also covers the energy simulation tools for the analysis of building in term of energy performance through an integrated BIM use.

Chapter 4 explains the research methodology in detail and encapsulating all the methodologies that are useful for this research with a rigorous discussion about some reasons and issues.

Chapter 5 establishes an initial and conceptual framework adopted from the best practices for building design optimization and energy efficiency with reasons and discussions on the main components included within the framework.

Chapter 6-7 explains the use and implementation of the identified framework from chapter 5 through the application of multi case studies in Gaziantep-Turkey. By adopting case study strategy, these chapters detail the required tasks for the identified components within the BIM based design framework for building design optimization in Turkey.

Chapter 8 deals with enhancement of the contextualized framework with findings from the analysis of building design projects in chapter 6\_7 by detailing the process,

technology, design rules and ontology and finally the energy assessment scheme perspectives

Chapter 9 deals with the validation of the overall BIM based design and optimization framework. This is done by examining the efficiency and effectiveness of the overall framework on a real building (health center) case study.

Chapter 10 draws up the conclusion, propose the refined BIM based design optimization framework for energy efficient buildings in Turkey, the achievements of objectives, and recommendations for the future works.



## CHAPTER 2

### LITERATURE REVIEW

#### 2.1. Energy Use in Buildings

Building is one of the main activities that humans influence resources and the environment. It accounts for about 40% of the total natural resources used by humans, accounting for 40% of the total energy use, and construction waste accounts for 40% of total waste from human activities (Gong et al., 2012).

Most developed economies account for 30-40% of their energy demand. In 2004, residential buildings alone accounted for 22%, 28% and 26% of the final energy demand in the United States, the United Kingdom and the European Union respectively. This makes the building one of the energy-intensive industries in advanced economies (Crawford et al., 2016).

As recorded by the International Energy Agency, the world's total energy consumption in 1971-2010 increased from 46.72 million tons to 86.77 million tons, making an increase of more than 46% (Figure 2.1). Moreover, during this period the amount of carbon dioxide emissions (CO<sub>2</sub>) increased by more than 48% from 15,637 million ton to 30,326 million tons of CO<sub>2</sub>. It's also sited that in 2012-2035 global energy demand will increase by more than one-third. Similarly, the British petroleum (2013) predicts that by 2010, global primary energy consumption will grow by 1.6 percent annually and by 2030 the energy consumption will make 36% of the global energy use (Samuel and Joseph, 2015).

According to Hassan et al. (2014), the international energy outlook report regarding the current energy consumption showed that from 2010 to 2040, energy will continue to grow 56%. In addition, the global total energy will increase from 524 trillion British thermal units (Btu) in 2010 to 630 trillion Btu in 2020 and this will continue to increase to 820 trillion Btu in 2040.

As mentioned by Hanna (2013), with over 50% of total energy consumption, electricity is the largest source of energy consumed followed by natural gas and LPG (liquefied petroleum gas). Moreover, the US Department of Energy (DOE) 2010 estimates that 74% of US electricity consumption and 40% of carbon dioxide emissions come from buildings. In Egypt, the residential building makes around 42.3% of the total energy consumption. This is due to the increase in artificial lighting and electric ventilation. In addition, the designers who design building does not take in account energy use in the design process (Aldali and Moustafa, 2016).

Rapid global energy use has raised concerns about supply difficulties, energy depletion and environmental impacts (depletion of the ozone layer, global warming, and climate change). Growth of population, increasing demand for construction services and comfort, and increased construction time ensure that future energy demand will continue to rise. In this regard energy efficiency today is the main objective policy at the regional, national and international levels (Pérez-Lombard, 2008).

The energy required to operate a building is known as energy demand. It can be defined as heating, heat loss cover, cooling energy, reducing heat, hot water, ventilation, lighting and other electrical appliances required. To determine the energy performance of a building, the site of the building, the purpose of its use and the time of its operation is needed. Moreover, the energy performance can be mainly affected by the shape of the building. In this context, the investors usually request different of unusual shapes to increase the attractiveness of the building. Accordingly, the more the building is fragmented, the more thermal lose recognized (Tauš et al., 2015). As a result, sustainable buildings that save resources and reduce the environmental impact of the life cycle (material manufacturing, planning, design, construction, operation, maintenance and disposal) have become a critical concern (Gong et al., 2012).

As stated by Kilpatrick and Banfill (2011), collecting data and analyzing the building energy consumption, can give an idea in how and when the energy is used in the building. Preparing seasonal demand of energy for both weekdays and weekends, average daily consumption for each month, can perfectly show how the energy is being used by the building. That's why, energy management is critical to achieve efficient energy buildings and reduce the environmental impact of the buildings energy conservation and decrease the environment impact of buildings. Thus, knowing the

how much the building will consume energy will bring more value to the building. Consequently, this will help the managers and building owners to plans of the amount of building energy usage over time and make more effective energy purchase plans (Li et al., 2013).

Energy conservation which is considered as an important sign of energy efficiency is to decrease energy consumption and increase energy efficiency at greatest level without affecting the economic level and living standards. As cited in the definition, the most critical concept is to reduce energy use by stopping energy losses. Recently, many studies in the literature were conducted on enhancing the energy use of residential building, in these studies different models have been created as a solution for this problem. In this regard researchers applied different types of approaches like building envelope, insulation thickness, window and HVAC. These approaches focus primarily on the development of a method of designing the most cost-effective residential buildings (De Boeck et al., 2015).

It's stated by Sangeli et al. (2014), that efficient energy actions means choosing and adopting approaches to correctly use energy. In this regard, constructing facilities to generate energy is costly and time consuming, that why reducing electricity consumption is highly needed. Moreover, there are other factors indicate the need for energy consumption enhancement like: Population growth, limitation of energy resources, high use of energy due to incorrectly use of it, existence of old industries and factories, and finally increase of greenhouse gases.

Due to the great amount of energy consumed in buildings, regulations about the building energy efficiency were developed. These regulations lead to an efficient building energy performance, including both retrofitted and new buildings. While these regulations can lead to a reduction energy consumption, enhanced thermal comfort, it is important to make sure that they will not result in an increased energy use at other stages of a building's life cycle (Crawford et al., 2016).

As stated by Liu et al. (2013), there are three main factors influence the energy performance of buildings, these are: the design of building envelopes, the design of system, and occupant's behavior. The impact of the first two factors on energy can be enhanced by making suitable decisions at the first stage of the design procedure.

According to Skopek (2013), the energy performance of buildings is impacted by many factors such as building's age, building's size, building's efficiency characteristics and finally management of the building including both monitoring and operation.

Other factors may affect the energy use in building, as mentioned by Zhu and Li (2015), in large public building there are huge use of energy. This is due to installing a lot of energy system like heating and cooling system, water supply system and lighting system. Therefore, while adopting energy efficient action, it is important to manage these systems scientifically because its makes a huge energy consumption causing a serious energy wasting.

## **2.2. Energy Performance and Energy Efficiency Features of Buildings in Turkey**

Energy efficiency is a key word currently found in all areas where energy demand exists. People and companies need to modify their activities in an efficient way because of the continuous increasing in energy use, energy shortage and soaring prices of energy resources. According to a study for European countries, buildings are the most energy user sector, making 40% of the total energy consumption. Furthermore, 3% can be ascribed to the residential buildings (Chwieduk, 2016).

The energy use has greatly increased due to population expansion, more time spent indoors, rising demand of building functions and global climate change. To achieve significant energy saving, buildings should be designed and operated properly. In this instance, efficient energy can be as a solution to energy shortage and CO<sub>2</sub> carbon emissions (Cao et al., 2016).

As mentioned by Yıldız (2008), the amount of energy used may differ from place to place due to the local factor in each country. It highly depends on developing living standard, comfort conditions. Since 1980, the energy use has duplicated and is expected to keep rising. According to a study done in Turkey in 2008, the energy consumed by building including residential and commercial buildings was up to 1,185 PJ. Furthermore, the ministry of energy expected that this amount of energy will grow to 2,000 PJ by 2020.

As cited by Eskin and Türkmen (2008), in Turkey, there is a need for efficient energy usage because buildings are responsible for a great amount energy use making around

half at present of total energy consumption, which will result in the increased CO<sub>2</sub> emission to the atmosphere.

According to a study done in (2000-2008), the residential building account around 80% of total existing building in Turkey and 80% of the energy is used for heating purposes. Therefore, there is a need to apply insulation practice to achieve better energy performance and avoid heat loss. It is also mentioned that 80% of the energy consumed come from the conventional fuel use.

Energy used in residential buildings is significantly high in Turkey, making around 40% of the total energy use. Considering the energy used by other types of buildings, and the increased fuel used, the influence of this sector the environment is greatly high. Based on the energy statistics in Turkey, the actual energy used by buildings ranged between 100 and 200 kWh/m<sup>2</sup> and the average is 175 kWh/m<sup>2</sup>. While in European countries, the total energy consumed including heating, cooling, and ventilation is around 100 kWh/m<sup>2</sup>. As a result, the energy used in Turkey is two times higher than the energy used in European countries (Kazanasmaz et al, 2014). Based on the facts mentioned above, it's necessary to focus and study the buildings energy consumption in Turkey.

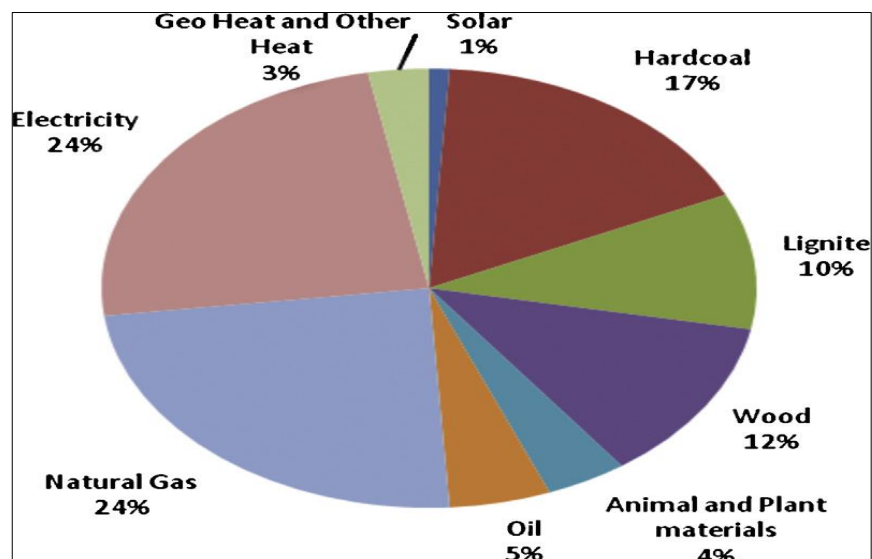

**Figure 2.1.** The breakdown of energy sources of building in Turkey (Kazanasmaz et al., 2014)

Although efficient design strategies are commonly used in in European countries as a regulation, they are still not implements as a design strategy for buildings in Turkey.

That's why the energy consumption in Turkey is significantly high, because of the lack of insulations standards and efficient design strategies (Bilgiç, 2003). He also stated that, a great amount of energy can be saved if the buildings are designed according to the principles of passive design. This statement necessitates to consider building design criteria as they strive towards protecting the nature at the highest possible level and providing the most suitable environment for people within the building (Gür, 2007). Thus, it is necessary to study the design components that impacts the energy performance of building

### **2.3. Components to be Considered in the Building Design for Energy Efficiency**

Energy efficient building is a sum of many actions. Consequently, efficient buildings strategies is to supply good indoor environment by considering the occupant behavior. Moreover, to increase building's value, the best efficient technologies and solutions have be taken in account. Thus, in the following sections there will be identifications of those components and strategies that must be taken in consideration when designing a building for achieving efficient energy building design. It's also worth saying that renewable energy technology is usually considered as a part on an energy efficient building sources.

#### **2.3.1. Climate features and building location**

Climate is mostly important because it directly impacts the buildings energy performance. The climate may affect energy consumption in several ways. In all types of building sectors especially in the warm places, it's necessary to provide people a cool indoor environment which will increases the electricity use in the buildings. While, in cold places, less energy consumption will be achieved because of less heating demand (Auffhammer and Mansur, 2014).

As cited by Cho et al. (2012), the increasing awareness of energy use and the impact of climate on building operations, designer and architects must put more consideration on energy performance and building's sustainability. That's why, building's location is very important in the design of energy efficient buildings, and it is usually considered in the design of new buildings. According to Cibse (2004), when designing a building, it is necessary to calculate for climatic conditions, also topography, landscape,



surrounding buildings and vegetation are vital factors in determining the building's site.

It's known that climate change will greatly impacts the way we live and work. That's why, numerous studies were conducted to build more efficient buildings that adopt efficient materials to decrease the heat gain and loss of envelopes and equipment inefficiency (Waddicor et al., 2016). The external temperature, humidity, solar and weather fluctuations, are the main climatic conditions that should be considered in the buildings design. For example, insulation type and level are mainly defined by the outside temperature. HVAC system is also affected by the climatic conditions. Furthermore, the existence of other building and topography may contribute to the solar radiation, local wind condition. Additionally, the use of local resources may have a great advantage like generating electricity form solar energy and wind (Bauer and Schwarz, 2009).

### **2.3.2. Building architecture and orientation**

Architectural design is critical in achieving energy efficient buildings. The building shape may lead to efficient building related energy. For instance, compact building shape will have minimum heat losses through its envelope materials and decreased exposure of weather conditions than complex building shape. This is due to the decreased surface area exposure. Particularly in cold places, building with compact shapes are able to save a great amount of energy and can help for organizing HVAC systems (Bauer and Schwarz, 2009).

Building orientation is also important in the building design. In term of orientation design, it should enable solar coming from south passing both lights and heat inside the building, which may result in eliminating the amount of lighting and heating energy consumed during cold time. Therefore, windows in south orientation with bigger glaze area is very useful. In other word, the ability that a building must naturally heat or light its internal may significantly influence energy efficiency and reduces energy use. This is often measured by building orientation (Abanda and Byers, 2016).

As mentioned by Morrissey et al. (2011), among the parameters that effect passive solar gain, building orientation is considered to be the most vital one. (Radwan et al. (2016) defined the orientation of building as a way the building positioned on site, the

position of windows and other structures. They also mentioned that the relative position of the Sun would help in more heat gain in buildings. In other words, making the right orientation of building is an important concern in passive solar gain. Furthermore, Wong and Fan (2013) suggested that to increase solar gain, as it is significant in cold weather conditions, it is necessary to place the building correctly in order to gain a large amount of solar radiation. Pacheco et al. (2012), declared that, orientation is a critical factor which greatly impact the energy use of building.

### **2.3.3. Building envelopes**

Generally, the amount of energy consumed to operate all buildings is majorly influenced by the interactions between building indoor factors and outdoor environment.

Building envelopes plays as the physical boundary that separate the conditioned building indoor spaces and outside conditions. It consists of external walls, roofs, ceilings, floors, windows, and doors. These materials work to organize the movement of energy between buildings's indoor and outdoor and have a significant role in keeping building's occupant comfortable from the outdoor conditions. It also helps in calculation the building energy performance during its operation (Jayamaha, 2006).

As cited by Mirrahimi et al. (2016), building envelope can be divided into two types, namely opaque including (walls, floors and roofs) and transparent including (windows, shy light and glass door), they can work to physically separate the inside of the building from outside environment, so they are exposed to humidity, rain, wind and solar radiation. As a result, it protects the inside environment as well as climate control at the same time. Latha et al. (2015) Said that, building envelope materials does not only separate the indoor from the outdoor, it also protects the building form the elements affect the building directly.

According to Abanda and Byers (2016), there are numerous factors that affect building energy use, most of them can be managed to achieve energy efficiency. Knowing the energy performance of building envelopes which are external walls, roofs, windows etc, will help in determining the amount of energy required inside the buildings. They also suggested that by enhancing building envelope and insulation, more energy can be saved.

As cited by Han and Taylor (2016), energy use can be decreased by enhancing the thermal performance of buildings envelopes. The ability of the envelope materials to store and release heat with a certain temperature can significantly decrease overheated hours and reduce energy used. Therefore, envelope materials are considered to be an appropriate method to enhance indoor conditions and decrease buildings energy consumption.

Cao et al. (2016) said that, building enclosure play a significant role in providing indoor comfort as they separate the indoor from outdoor environment. Furthermore, they developed efficient strategies regarding building envelope materials including (walls, fenestration and roofs). Regarding their review, enhancing building envelope generally depends on two approaches: decreasing (U-value) thermal transmittances combined with passive heating or cooling. The U-values of envelope material remarkably impact building energy use by decreasing heat gain or loss partially under harsh environment situations.

Regarding envelope materials, Judkoff (2008) said that, it's also useful to use high thermal resistance materials. It will be more useful when used properly in the right climates. The use envelope materials is widely different between developed countries like Europe and USA, and developing countries. Therefore, to ensure thermal comfort, in most part of the world, buildings are built using local materials considering local environment conditions (Sarkar and Bose, 2015).

Generally, the performance of building envelope is affected by three parameters (Raji et al., 2016):

1. Enclosure design parameters: glazing type and area, and window shading.
2. The properties of building materials like thermal mass and insulation.
3. Side and location parameters such as orientation of the building, and climate properties.

It is important to examine many alternatives of building designs that will not only achieve low energy and low carbon emission, but also decrease the time of the energy consumption during the use stage. Hence thermal mass and insulation plays a crucial role in achieving efficient energy performance. In other words, any enhancement in

the thermal performance of envelope material will lead to a great reduction in energy use and low carbon emission (Lawania and Biswas, 2016).

Based on the facts mentioned above, building enclosures and envelopes have a great impacts on buildings energy performance. Since there are many enclosure parameters, thus, there will be a brief explanation and definition of these parameters in the following sections.

### **2.3.3.1. Walls**

The wall is the main part of the building envelope and is expected to provide thermal and sound insulation within the building without affecting the building's appearance. The wall's thermal resistance (R value) plays a great role in influencing building energy consumption, especially in high-rise buildings with large wall area and large total area. Generally, based on the materials used in the construction, wall's types are classified into wooden walls, metal walls and masonry walls (Sharma, 2013).

As cited by Cao et al. (2016), there are some types of wall a passive heating technology can be implemented based on the solar heat gain. For instance, trombe wall typically is a passive heat wall that efficiently can absorb and transmit solar energy into a building. In this regard, they have done a study using trombe wall with roller shading, they found that trombe wall led to 42% energy saving. Another study carried out by Omrany et al. (2016), who reviewed few types of passive wall such as trombe wall, autoclaved concrete wall and double skin wall and green wall in building. They studied their effects to improve building's energy efficiency, and they concluded that:

- 1- Trombe walls is recognized to reduce the energy consumption significantly
- 2- Autoclaved concrete wall is recognized to work as a promising solution in reducing energy consumption.
- 3- Double skin wall is recognized as promising resolution in decreasing the building energy use.

Using green wall system in buildings impacts both indoor temperatures and outdoor environment. In other words, it is considered as an insulator material to decrease undesired solar penetration in buildings.

### **2.3.3.2. Roofs**

Roof is another opaque component, it calculates the buildings indoor comfort conditions which in turn affect the conditions for occupants. This is due to its exposure to solar radiation and other environment factors. In general composite roofing system is preferred to produce the required roof specifications, taking in account the weather condition and building location. Roofs can significantly be implemented as a passive cooling technique especially in tropical climate (Goia and Gustavsen, 2015).

As cited by Sadineni et al. (2011), the roof is an important part of the building envelope that is highly exposed to solar radiation and other environmental factors, affecting the indoor comfort of the occupants. Roofs contribute to substantial amounts of heat loss and gain, especially in the buildings with large roof area. According to UK building regulations, the maximum U-value used for flat roof building in 1965, 1976 and 1985 were 1.42W/m<sup>2</sup> K, 0.6W/m<sup>2</sup> K and 0.35W/m<sup>2</sup> K, respectively. Presently, in UK the required U- value for all new buildings is equal to 0.25W/m<sup>2</sup> K or less. The decrease in the U-value over the years shows the significance of thermal performance of roofs in order to increase the overall thermal performance of buildings.

Some passive cooling techniques could be implemented by modifying the roof construction. These include a compact cellular roof layout with minimum solar exposure, domed and vaulted roofs, naturally or mechanically ventilated roofs, and micro ventilated roofs, high roofs and double roofs. Other methods such as white-washed external roof surfaces to reduce solar absorptivity, roofs covered with vegetation to provide humidity and shade, and usage of high thermal capacity materials such as concrete to minimize peak load demand are also gaining popularity. Roof shading is one way of reducing the impact of solar radiation on the roof surface. Economical roof shading is usually achieved with local material such as terracotta tiles which can usually decrease the temperature of the indoor by 6 C° (Sharma, 2013).

### **2.3.3.3. Insulation**

Generally, buildings make around 40% of the primary energy use as well as CO<sub>2</sub> emissions. The use of insulation in building envelope can effectively and significantly decrease the energy consumption (Saadatian et al., 2016).

As mentioned by Ajeel and Yusof (2016), Building insulation strategies need to be carefully considered based on the energy transfer model and its direction and intensity of movement. This may change throughout the day and season. It is necessary to select a proper envelope design, the appropriate combination of building materials and techniques is to suit a specific condition. Insulation materials play a significant role in decreasing building electricity consumption, which in turn it will lead to a huge cost saving and a great reduction in gas emission that cause environment pollution.

The insulation of building envelopes is an efficient way to reduce buildings energy consumption and limit the negative environmental impacts of the buildings sector. As, insulation materials have apposite effect on the environment, they also have negative effects regarding their embodied energy. Generally, the impact of insulation materials can be classified into two types: direct impact and indirect impact. The direct impact is due to the embodied energy of the insulation materials. While, the indirect impact is about the reduction of operational energy use in buildings (Biswas et al., 2016).

There are many types of form of insulations, it can take the form of loose or spray on cellulose fibers, fiberglass or mineral fiber batts, or solid or spray-on foam insulation. Solid foam insulation is widely used as an external insulating material for commercial buildings because it can be directly attached to cast concrete or block walls. It is also sometimes used as an outer layer in a wood-framed building in which the studs have fiber insulation as it can span the thermal bridge generated by the stud. Other types of insulation material can be used for building such as: expanded polystyrene (EPS), extruded polystyrene (XPS), extruded polyurethane (PU), and rock wool (RW) (Harvey, 2007).

In this scope, insulated building envelope, both opaque and transparent, is considered as an important strategy for building energy efficiency. The insulation of walls, roofs, basements, and even foundations is one of the most important characteristics of energy efficient buildings. In addition, due to the poor insulation of the glass, insulating transparent envelopes, windows and skylights, the heat loss and gain are significantly reduced in both winter and summer (Kim and Moon, 2009).

#### **2.3.3.4. Windows**

Windows are considered one of the most important building components and is estimated to have a positive impact on the health and well-being of buildings. In addition, windows not only play a significant role in providing daylight, but also play a vital role in eliminating the overall energy consumed by the buildings. While it represents a small area of the building envelope, it has the highest impact on heat flow than floors, walls and ceilings of the building. Thus, it has to be considered as it influences the energy need of the building (Muhaisen and Dabboor, 2013).

Acosta et al. (2016) mentioned that, daylighting visual comfort rely on the maximum daylight autonomy. In addition, the energy consumption in electrical lighting depends on daylight autonomy, this means that proper use of lighting is essential to reduce the energy consumption of electric lighting, while maximizing the visual comfort of the inhabitants. Thus, the windows form the biggest factor in allowing daylight in buildings. Furthermore, the light transmittance of the glass profoundly affects the efficiency of daylight that causes energy saving. When the glass transmittance is reduced, the lighting energy saving is also reduced.

Generally, windows thermal performance can be determined by three factors, which are the total solar energy transmittance (g-value), thermal transmittance (U-value), and air leakage (L). These factors determine the amount of heat flow through a window (Urbikain and Sala, 2009). The glazing types and glazing layers is considered as a significant factor when designing windows, designers should take these factors in consideration during the design stage, because this can affect the amount of light transmit into the building spaces and the amount of solar heat gain, which in turn maximize the cooling load (Mirrahimi et al., 2016).

A round 25-30% of heat loss in a building is recorded when they are poorly insulated (Halder, 2008). Besides the shading devices, there are three other parameters that calculated the heat gain and heat loss through windows, these parameters are: window to wall area ratio (WWR), window orientation, and the thermal properties of glass material (Koenigsberger and Ingersoll, 1974).

The number, size and performance of the windows have a significant impact on the heat loss of the building. Therefore, the window must be carefully designed. First, the

heat loss in the window can be reduced by increasing the thickness of the window by installing more than one glass layer and allowing the air gap (or some insulating gas) between the layers. In addition, the use of blinds and blindly affect the thermal conductivity of the windows. Window frames and other structures may also produce a lot of heat, especially in the old buildings is also considerable (Seppänen and Seppänen, 1996).

This research considers the above mentioned parameters for window design in respect of the heating and cooling energy requirements under the local climate conditions for a building.

#### **2.3.3.5. Shading**

Proper shading design and selections are important to achieve energy efficiency and comfortable indoor environments. Due to the huge development in buildings sector together with the energy and environmental problems, many studies were conducted about shading and fenestration system, this is to effectively control the solar heat gain and daylight. Proper design of overhangs shading systems will play a great role in reducing the unnecessary solar gains in buildings (Ali and Ahmed, 2012).

One of the benefits of shading system is it impact the daylight level in buildings and also the view of outside environment, they also eliminate the annually solar gains and organize the flow of energy throughout glazing building envelope. Thus, shading system impact building energy consumed for heating, lighting, cooling, and occupant's thermal comfort (Bellia et al., 2014). Although, shading can reduce heat gains in buildings, it is frequently used to give stylistic impressions, like the poor designs of windows (Butera, 2005).

In order to make a balance to make a balance between the aesthetic of the glass and their level of solar radiation transmission, various shading systems can be integrated into the design, both internal and external besides fixed and movable. In addition, internal shading systems are less efficient in terms of heat gain because they block solar radiation after passing through the building. Thus, internal shadings can more effectively control the light passing through the building, but not the solar radiation. (Yassine and Abu-Hijleh, 2013). On the other hand, external shading has proven to be the best type of shading as it blocks solar radiation to its source as much as possible.



Around 11% energy saving can be achieved by using external shadings (Kim et al, 2012).

Shading devices are considered to be an important tools to reduce the building energy use specifically in hot places. In summer time, shading protects buildings windows from unwanted solar, while in winter time it enables maximum solar radiation into the buildings. Many types of shading are in place such as external shading internal shading, overhang shading, venetian blinds and canopy. But, the resulting decrease of daylighting may lead to increase the amount of energy used for lighting. Therefore, it is necessary to make a balance between energy saving and occupants' comfort conditions (Eskandari et al., 2017).

#### **2.3.4. Renewable energy practices**

Recently, because of the rapid growth of energy consumption, worries have been arisen about the reduction of global oil and other resources. Due to, industrializations and population growth, todays our economy and technologies greatly depend on natural resources, which are not replaceable. The high use of fossil fuels has caused different types of visible damage to the environment. Around 90% of the energy used comes from fossil fuels (Alrikabi, 2014). Additionally, the fast reduction in fossil fuels and their negative impact on the environment are slowly making the world economy to be more sustainable renewable energy (Sulaiman et al., 2013).

To solve future environmental issues and other measures, the present energy generation technology should be changed. Due to the traditional generation technologies such as coal burning have an adverse impact on the environment, so the international community has turned to be more environmentally friendly generation of renewable energy such as solar and wind. It is also mentioned that the application of renewable energy will not only lead to further modernization of the energy sector, but also achieve national economic and sustainable development goals (Inglesi-Lotz, 2013). Renewable energy can ensure the sustainability of electricity supply while reducing carbon dioxide emissions (Sulaiman et al., 2013).

Globally, energy demand is still increasing especially electrical energy. The oil prices are increasing as well as pollution continue to increase, this is due to burning of fossil

fuels. All these issues drive to investigate the using of solar, wind and other type of renewable resources in order to generate (Kazem and Chaichan, 2012).

Nowadays, developed economies encourage renewable sources to improve the supply and reduce greenhouse gas emissions (GHG). For instance, the European Commission's objective is to rise the use of renewable energy by 20% by 2020 (Moselle, 2011). This is also supported by Gurung et al. (2012), who said that, in developing countries, renewable energy is seen as a favorable option for increasing rural electrification and enhancing power access in areas where power infrastructure is centralized, furthermore, renewable energy provides a great opportunity for rural electrification, this is due to the fact that, technology can make better use of local resources such as: hydropower, solar, wind and geothermal.

There are diverse types of renewable energy sources such as wind and solar energy that are constantly added and will never run out, which is a benefit. Most of the renewable energy comes directly or indirectly from the sun. Sun or solar energy can be used directly for heating and lighting homes and other buildings for power generation, as well as for hot water heating, solar cooling and a variety of commercial and industrial uses (Alrikabi, 2014).

Presently, the common renewable energy sources used are biomass, hydropower, geothermal energy, solar energy and wind energy (Sulaiman et al., 2013). However, in this research we will take a comprehensive review on the solar energy renewable technology.

#### **2.3.4.1. Solar energy photovoltaic (PV) technology**

Photovoltaic is usually used to convert solar energy directly into electricity. This energy conversion takes place in the solar cell. A packaged, connected assembly of solar cells is called a PV module. It could be integrated with building elements, like roof, wall and window. Usually the PV module is classified according to cell type: monocrystalline silicon (m-Si), polycrystalline silicon (p-Si), amorphous silicon (a-Si) and compound semiconductor such as copper indium selenide (CIS) (Zhu, 2014). Peng et al. (2011) cited that, the electrical power generated by photovoltaics is achieved by the process of converting solar radiation into current electricity by using

semiconductors. Moreover, photovoltaic power is already generated by using solar panels where are composed of many cells having photovoltaic materials.

Oni and Bolaji (2011) stated that, photovoltaic generates energy through the process of turning the sunlight to electricity by using photovoltaic cells which is called solar cells. But, the energy generation of one cell is 1 or 2 watts, which is not enough power. In order to rise the power generation, cells are electrically connected into a packaged weather tight modules. These modules can be connected to create an array (see figure 2.2). PV array performance is mainly depend on the sunlight. That's why, the climatic situation has a vital impact on the amount of solar received to the PV arrays also its performance. There are two types of PV power systems, solar PV and solar thermal conversion. Solar photovoltaic converts heat to electricity directly, while solar thermal generates a stream by heating the liquid by using the thermal collectors, and then generate electricity. It is also mentioned that recently, the solar PV has reached the greatest growth of 28%, second only to wind energy. Moreover, recently, the capacity of solar PV has reached by 55% around the world (Shakeel et al., 2016).

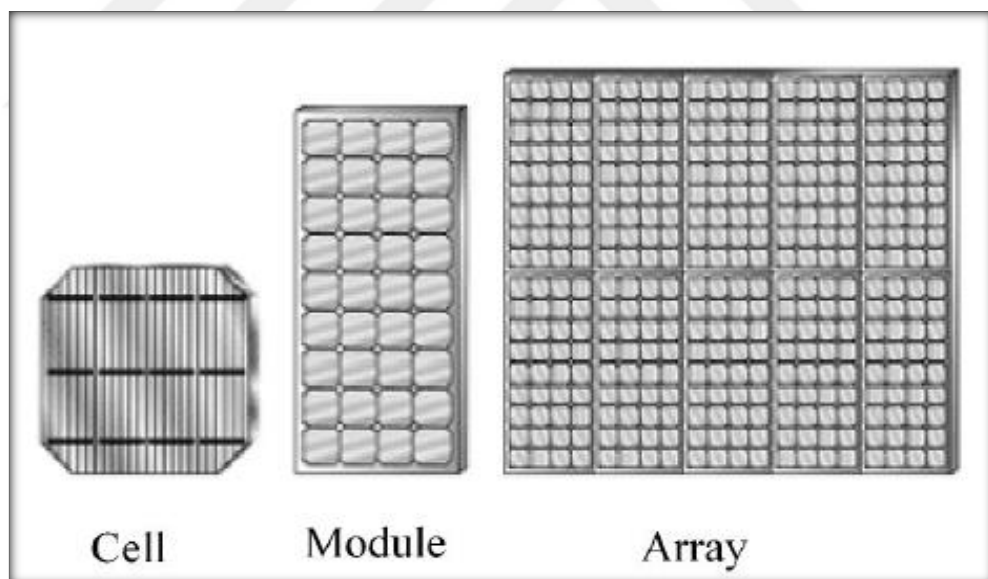

**Figure 2.2.** Different types of solar cells arrangement (Oni and Bolaji, 2011)

Nowadays, there is a growing awareness that renewable energy should be implemented as it can play a vital role in supporting social facilities such as electricity. Among the different types of renewable energy, superior attentions went to solar energy, this is due to it is freely available. Moreover, solar energy is the driving force behind many

of the renewable forms of energy. Solar energy is a perfect alternative source of energy due to the fact it is available for free and unlimited (Zhu and Li, 2015).

Freire et al. (2010), explained the importance of using solar energy by saying that there are several ways to provide electricity, the use of solar energy for the industrial, public, commercial and residential sectors has been discussed in many countries as one of the workable solutions to decrease global warming, and this is to avoid generating energy by fossil fuel. Moreover, the electricity generated by using the Sun's energy decreases the amount of energy generated from non-renewable resources such as coal, gas, and oil and nuclear. Furthermore, by applying solar energy systems to the buildings energy will not be wasted, it can provide a significant environment benefits by reducing air pollution caused by burning fossil fuels, reduces the use of water and land for central generation plants, finally, the energy produced by solar technology does not make noises and there are a few moving parts.

In many places, solar energy is not used because they have oil and it is cheap and obtained easily, also there is no encouragement to use other types of energy and environmental protection is not a main concern (Abed et al., 2014). Furthermore, as mentioned by Yoon et al. (2011), there are no clear technical alternatives in the construction sector to save energy. That's why, self-energy generation buildings are getting more interest to command the industry in the future. Therefore, it is necessary to invest in this type of technology.

#### **2.3.4.2. Solar energy practices in Turkey**

Lately, with the obvious increase in climate change, energy, economic and environmental issues should be considered. Among these issues, energy is a key parameter of environmental impact. To reduce energy-related environmental impacts and improve the security of energy supplies, there is a need to reduce dependence on imported fuel supplies and increase the use of renewable energy. In this regard, Turkey's visions regarding climate change is to become a country totally incorporating objectives to increase energy efficiency as well as renewable energy technologies, making active effort to deal the climate change issues and provide building occupants welfare, good quality of life with less carbon emission (Mangan and Oral, 2016).

To reduce carbon emission and encourage buildings with self-sufficiency, there is a need to integrate energy generation systems in the buildings. Solar generation system is considered to be an efficient system in which buildings can be an energy supply structures. Therefore, according to Climate Change Strategy Document of Turkey, which foresees year 2020 to integrate Turkey's future development and environmental plans, the purpose of increasing renewable energy use in buildings was identified as at least 20% of the annual energy demand of new buildings was met via renewable energy resources as of 2017 (Mangan and Oral, 2016).

Although the geographical location of Turkey has advantages for using renewable energy especially solar energy, it is still highly relies on the exported energy. That's why, encouraging for in site energy generation, as well as renewable energy technologies to satisfy buildings energy needs, is considered to be a key measure for solving energy issues of Turkey as well as for resolving the energy related challenges of Turkey meanwhile reaching sustainability. In addition, as Turkey has the third largest installation of solar capacity, the use of renewable energy is still not successful (Esiyok, 2007). Therefore, there is a need to integrate such technology in the buildings design to eliminate building energy use and achieve sustainability.

#### **2.3.4.3. Buildings integrated photovoltaic (BIPV) system applications**

The BIPV system consists of photovoltaic materials used to replace parts of envelope materials such as roofs, skylights and facades. They are more considered for power supply in new buildings and can also be used for existing buildings (Peng et al., 2011). It attract the attentions of many stakeholders, because they consider it as multifunctional tool whether a buildings materials or energy generator device (Dos Santos and Rüther, 2012).

According to Ordenes et al. (2007), replacing PV elements with parts of building envelop materials is the most preferable use, this is due to the fact that PV modules can work as a power generator source and a building element in the same time. Yoon et al. (2011) mentioned that, BIPV works to provide efficient PV system by using PV modules instead of building envelope materials and thereby enhancing various principles such as economic efficiency.

The main difference between integrated and non-integrated photovoltaic system is that the original cost can be offset by eliminating the cost of building materials and labor for parts of the building replaced by BIPV modules. That's why, BIPV is the most important sections of the photovoltaic industry (Peng et al., 2011). In particular, the economic efficiency of BIPV systems has increased with the replacement of high-priced building exterior materials that are frequently used in recent buildings. In addition, BIPV systems can save on electricity costs and reduce the environmental impact of not using fossil fuels for power generation. Mainly, BIPV systems do not require separate site acquisition costs to install the system and eliminate the cost involved in establishing a support system structure that is required by existing stand-alone PV systems. In addition, the system can reduce distribution losses because electricity is generated where electrical loads occur (Yoon et al., 2011).

In some places, installing PV system on building roof is used greatly. System design is primarily influenced by PV performance considerations, and aesthetics are usually secondary. Commonly, the development of multifunctional photovoltaic products that combine with building materials is important because consumers are increasingly interested in distributed photovoltaic technology and industry competition to reduce installation costs (James et al., 2011).

The integration of solar modules building roof is considered to be one of the most effective applications for photovoltaic (PV). As the cost of the technology decreases, building integration and building applications (BIPV and BAPV) can help generate electricity in urban environments efficiently and cost-competitively (Dos Santos and Rüther, 2012). Photovoltaic system design has different levels of integration with building materials and architectural features (see figure 2.3). PV systems are beneficial for many reasons. They are used to turn the sunlight to electricity directly, so that there is no need to use mechanical appliances. Moreover, the PV system has no movable parts, it only requires a number of simple labors to fix the system and maintain it (Oni and Bolaji, 2011).



**Figure 2.3.** Different design integration of PV system (Dos Santos and R  ther, 2012)

Building photovoltaic arrays are classified into two types: BIPV and BAPV. BIPV is considered to be a functional part of the building structure, or they are integrated into the architectural design of the building. This type includes designs that replace traditional roofing materials such as shingles, tiles, slate and metal roofs. From an aesthetic point of view, it may be attractive if you want to maintain the continuity of the building and not attract attention to the array. BIPV modules can also be architectural elements that enhance the look of the building and create a very desirable visual effect. An example of BIPV in which PV arrays are fixed on the roof is shown in figure 2.4.



**Figure 2.4.** BIPV arrays are combined with the roof ( Peng et al., 2011)

BAPV is considered an add-on to the building and is not directly related to the functional aspects of the structure. They rely on the superstructure that supports traditional framed modules. BAPV system is classified into two categories which are standoff and rack-mounted arrays. Standoff arrays are fixed on the roof a long with the slope of the pitched roof. While, rack-mounted arrays are usually mounted on a flat roof in a way the PV modules can be mounted at the best orientation and tilt angle. The BAPV in which the PV arrays are attached to the roof are shown in figure 2.5 (Peng et al., 2011).



**Figure 2.5.** BAPV arrays are attached to the roof ( Peng et al., 2011).

#### **2.4. Previous Studies**

In this section, a comprehensive review for those studies which examined the impact of various factors related building design in term of their energy performance will be conducted. Thus, the current literature will focus on reviewing the studies about the components related building design for the purpose of ensuring sustainable and energy efficient buildings design.

Eskin and Türkmen (2008), conducted a study to analyze the heating and cooling energy needs for office building in various climates in Turkey. The performance parameters studied were building location, insulation, aspect ratio, external surfaces color, shading, windows area and systems, and ventilation rates. Building energy simulation program was used to carry out the study, Energy Plus was used to determine



the amount of cooling and heating need. The results showed that, all the parameters have an impact on the energy performance of building.

Another study done by Yıldız and Arsan (2011), to calculate the impact of the most important parameters on building performance in hot and humid climates for an existing building apartment in Izmir-Turkey. Monte Carlo method and Latin hypercube sampling (LHC) technique was adopted to carry out the analysis. As a result the study showed that, the impact of parameters on building energy performance changes according to the locations of the building such as ground intermediate and top floors. In addition, windows performance parameters including area, heat transfer coefficient (U value) based on their orientation have a great impact on the energy performance of building in hot and humid climate.

Raji et al. (2016), assessed the energy saving solutions for the envelope design on high rise buildings in temperate climates in Netherland. Design Builder software was used to determine the energy performance of the building before and after improvements. Four main design parameters were chosen to improve the building energy performance which are window to wall ratio, glazing types, shading and roof strategies. The results showed that, all the studied parameters have an impact on building energy performance, around 42% saving was achieved in the total energy use, 64% for heating and 34% for lighting.

Sarkar and Bose (2016) conducted a study about the effects of opaque building envelope on building energy performance. E-QUEST simulation tool was used to analyse and calculate the annual energy use and savings. The results showed that, using insulation materials for both walls and roofs will maintain comfort conditions and also enhance building energy efficiency. Heating and cooling energy consumption were decrease up to 60% and 40% respectively.

Another study was conducted by Abanda and Byers (2016) about the effect of orientation on domestic building energy performance through the use on BIM. The results showed that, a well orientated building lead to a significant energy saving throughout the building life time.

Ayyad (2011), studied the effects of orientation, window to wall ratio, and envelope materials on building energy performance in tropics. Environment solution IES<VE>

tool was used for simulation. The results showed that, well building orientation and efficient envelope materials will make a great saving in the building energy use.

Harmathy et al. (2016), conducted a study about enhancing building envelope materials in term of indoor illumination quality for efficient energy performance. They tried in their study to calculate efficient window to wall ratio, window geometry in term of indoor illumination quality and also studies the impact of glazing parameters on the total energy performance. CAD was used to create the model, radiance and energy plus were used to perform the simulation. The results showed that, it is possible to decrease the heating and cooling energy requirements to 51.49 KWh/m<sup>2</sup>/a compared to the actual building energy consumption which is more than 150 KWh/m<sup>2</sup>/a.

Radwan et al. (2016), conducted a study to enhance the existing building energy performance in Egypt. Carrier's Hourly analysis program was used to conduct the model simulation and analysis. The results indicated that, the yearly electrical saving reached 41%, and insulating walls will contribute to 8% decrease in the building energy consumption.

Aldali and Moustafa (2016), examined a study about how to reach energy efficient design for housed in Egypt. Autodesk Ecotect was adopted to determine the actual building lighting and energy performance. The results showed that, the characteristic on buildings envelope will greatly impact the buildings energy saving.

Waddicor et al. (2016), investigated the impact of climate change and building ageing on building energy performance in northern Italy. An advanced building simulation software, IDA ICE, was used to determine the current building energy performance. The result showed that, a round 87% decrease in the cooling energy consumption is achieved.

Konstantinou and Knaack (2013), discussed an integrated renovation method as a way to enhance building energy efficiency. This aim of this method is to include energy performance in the design process of renovation strategy. Various renovation methods are suggested, and the impact of each one is evaluated. They applied the suggested methods on a real building case study. The results showed and enhancement equal to 90% in the building energy performance.

Capeluto and Ochoa (2014) presented in their study, a simplified method for determining preferred strategies and combinations in the early design stages of a building. These strategies was about envelope materials such as glazing shading and insulation. Through the use of simulation tool, six main improvement were modelled to identify the preferred configurations. Consequently, a total scheme was established categorizing the energy ranking of each improvement for the studied climate façade orientations.

Song et al., (2017), carried out a study on energy assessment on office building envelope in China. TRNSYS software was used to develop the actual building model. Six envelope materials were considered and analyzed. The results showed that, the thermal transmittance (U value) of exterior wall, infiltration rate, ventilation, and shading will lead to a significant amount of energy saving equal to 91.06%.

Ahmed et al. (2011), conducted a study to develop an energy code for residential buildings by using simulation tools, a single-family house were considered in the study. The study focused on walls and roof insulation as well as glass upgrade and adding a renewable energy source for the unit. consequently, they established a roadmap for enhancing residential energy code and the the aspects through which energy simulation software can play a key role in enhancing Egypt Energy Code for Residential Buildings are recommended.

## **2.5. Conclusion**

In this chapter, a general overview of the building energy use and the current energy consumption of building in Turkey was explained. The main factors affecting the building energy design and performance were investigated and reviewed. Renewable energy practices and their contribution to efficient energy building was also identified. Finally, different studies regarding the impact of different building design parameters as well as renewable energy on building were also reviewed. In most of these studies both BIM and energy simulation tools were used, and it showed that the use BIM and energy simulation tools promises a good and significant energy solutions to the building. Thus, in the next chapter, there will be a comprehensive review of BIM, its importance and its application in buildings for the purpose of ensuring sustainable and efficient building design in Turkey.

## CHAPTER 3

### BUILDING INFORMATION MODELLING AS A NEW WAY OF SUPPORTING SUSTAINABLE BUILDINGS DESIGN

#### 3.1. BIM Definition

BIM can be defined as a couple of processes and modeling technology to create communicate and analyze buildings models. It is rapidly converging to call for an integrated and collaborative process containing all disciplines throughout the building life cycle (Gerber et al., 2010). It uses ICT technologies to simplify buildings life cycle processes in order to the building lifecycle processes to deliver a safe and more productive environments for its users to achieve better environment impact from its existence and to be more efficient for owners during the building life cycle (Arayici et al., 2012).

As mentioned by Eadie et al. (2014), BIM is defined as Computer Aided Design (CAD) paradigm producing “a set of interacting policies, processes and technologies producing a methodology to be able to manage buildings design and data in a digital format during the building lifecycle. They also stated that governments promoted BIM to encourage collaboration and decreasing disintegrations in the construction industry.

Sebastian et al. (2009) stated that, BIM is different from earlier known computer-aided design (CAD). BIM goes further than digital (2D or 3D) drawing or centralized databases. It is a computable representation of all physical and functional characteristics of a building. In addition, its final form offers the possibility of the final information models to be handed from design teams (architects, surveyors, consulting engineers and others) to contractors and subcontractors to customers. BIM can integrate information from project participants from different disciplines that traditionally work at different stages of the building life cycle.

From a technical point of view, the Building Information Model is a project simulation that contains a 3D model of the project components that contains links to all the

necessary information related to building planning, design, construction or operation. Although the roots of BIM can be traced back to parametric modeling studies in the United States and Europe in the late 1970s and early 1980s (Azhar et al., 2015).

BIM is basically both a software approach and a way to design and build buildings, using highly coordinated and internally consistent information about the buildings, from early design to construction to post-construction and asset management (Rajendran et al., 2012).

### **3.2. The Importance of BIM**

Recently, the use of BIM in the design and construction industries is increasing. This is because it facilitates collaboration between many disciplines and facilitates the extraction of knowledge accumulated in several simulations that can be used to define and develop product development standards and recommendations. Mainly, when using BIM for modeling projects, the BIM model itself can be used to establish many efficient solutions (Bynum et al., 2012).

The implementation of BIM has been seen in many large construction projects, such as the commercial and industrial real estate and infrastructure sectors. It is one of the most important supporting factors for successful integrated design. It can integrate information from project participants from different disciplines, often working in different stages of the building process (Sebastian et al., 2009). BIM's success is deep because it makes design easier, enables comprehensive energy analysis, and significantly improves the accessibility of design information to stakeholders (Diao et al., 2011).

The demand for BIM is increasing because it has the potential to reduce costs, reduce timeframes, and reduce design conflicts issued on the project site, thereby reducing delays and reducing cost overruns (Rowlinson et al., 2010). To date, many construction projects have reported the benefits of using BIM technology and recommended as an emerging approach that will help the building industry achieve lean building principles by reducing waste, cut costs, increase team productivity and create positive project outcomes (Gerber et al., 2010). In addition, it provides a more streamlined business process, related project and site management methods, including full facilitation of construction knowledge throughout the life of a building project. BIM as a life cycle

assessment concept designed to integrate processes throughout the lifecycle of a building project (Arayici et al., 2012).

As cited by (East and Brodt, 2007) and (Smith, 2007), the reason behind using BIM is that it can be used to develop an integrated shared knowledge source that covers all the needed designs and necessary operational information of projects. In general, 3D technology is used to propose design solutions, there is no real field application, and there is no collaborative spirit between team members to promote its use. BIM takes this concept to the next level by creating 3D models using actual engineering and building data instead of creating models using artistic 3D design software. This allows the 3D model to be updated by changing the database containing the specification instead of the actual model itself. With this advantage, BIM is used to recognize and reduce errors and design conflicts and call for information before the project begins. Centralizing the dataset also helps maintain a consistent data format, eliminating the confusion that different participants experience.

As mentioned by Zhang et al. (2016), all the stakeholders including, architects, cost estimators, engineers, builders, and owners can manage their project in a very timely manner throughout the use of BIM. It enhanced enterprises communications across the entire construction industry. It helps managing data and information through the building life cycle. In other words, BIM can show its value in managing the building design, bidding, construction and operation.

As described by Sheth and Malsane (2014), BIM is not only a 3D modelling tool, it also provides beneficial information, data about different project aspects such as design and construction process scheduling and quality, fabrications, and also provide the needed information about stakeholders and managers.

In this scope, Biswas et al. (2008) stated that, with the use of BIM, there is a great chance for engineers and architects to be a digital mater and superior builders, in which the can see the building materials, construction and performance in a real time in the early design stage. In the meantime, BIM model can supplies a well-coordinated package of information and documents efficiently that is consistent and correct.

The most notable benefits of BIM in projects is that, it eliminates construction clashes, enhances collective understanding on design intent, enhances the quality of projects,

leads to less changes during construction and eliminates requests for information, and predicts and controls project costs effectively (Young et al., 2009).

As proposed by Succar (2009), there are three main fields in BIM with many participants involved in these fields (see Figure 3.1).

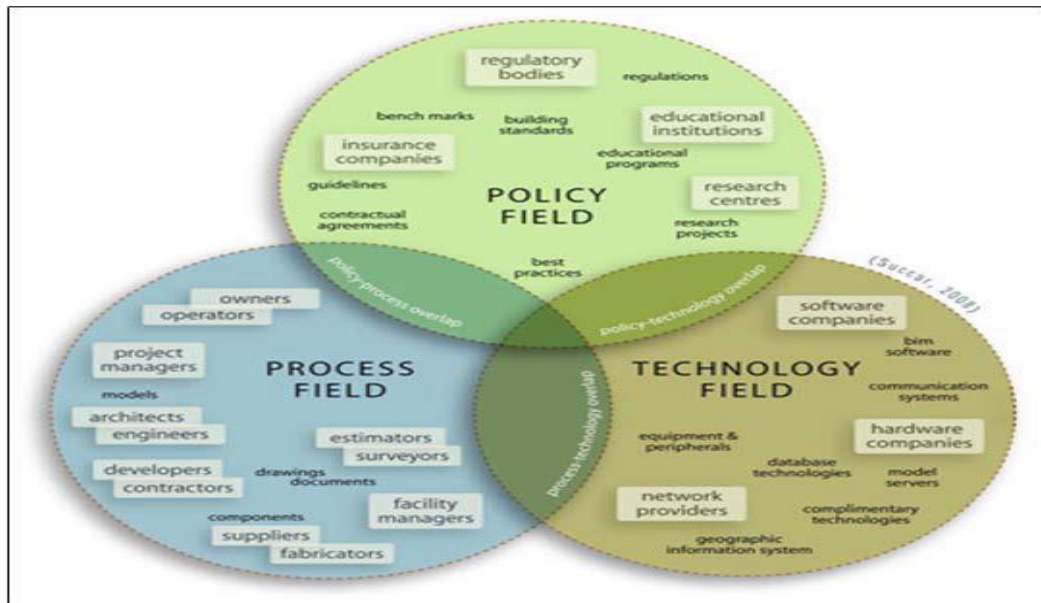

**Figure 3.1.** The three BIM fields (Succar, 2009)

As shown in figure 3.1, the fields of BIM are classified into three main steps which are:

- **Technology field:** movement from drafting based to object-based workflow.
- **Process field:** model-based collaborations.
- **Policy field:** includes integrated practices.

In addition to the collaborative process support, BIM can also be used in different areas of the AEC industry through its ability to attribute spatial and geometric and non-geometric attributes to architectural elements, such as sustainability analysis, structural analysis, thermal simulation, daylight simulation, construction management, cost estimation and planning, fire protection, safety on construction site, and facility management (Gourlis and Kovacic, 2017). In general, the benefit of BIM can be summarized as follows: (Azhar et al., 2009) and (Higgs and Stokes, 2008)

- Provide a comprehensive and coherent understanding of the project while controlling each departmental area.

- Enhances the way information are managed and visualization.
- It is possible to use the created models for simulation and visualization at any stage.
- Information and documents are kept centrally and automatically updated.
- Superior coordination as the data are stored in one file.
- It can provides renovation and maintenance at any stage.
- Encourage collaborations, audit ability and maintainability.

### **3.3. The Employment of Building Information Modelling (BIM) in Construction**

Nowadays, BIM is greatly used to help in designing, conceiving, constructing and operating buildings in many places, especially in the United States (Wong et al., 2009). By using BIM, a good quality of information can be provided which help in making effective design decisions about the buildings and the environmental impacts (Dowsett and Harty, 2013). The use of BIM need the support of both clients and managers. Mainly, buildings projects have many parties that require a great deal of direction to finish the projects successfully. That's why, the collaboration between stakeholders such structural engineers and architects are highly needed to achieve this goal. In this respect, BIM offers a unified master data set for all projects participants to increase the communications between them in the construction process (Rowlinson et al., 2010).

Digital constructions lead to increasing construction productivity by highlighting the growing fragmentation problems. That's why the use of BIM is recommended because it looks to integrate processes during the construction lifecycle (Alaghbandrad, 2015).

The ability of BIM to effectively build a building before the creation of an actual building provides an effective way to check its constructability in the real world and address any uncertainty in the process. This enables a more efficient design structure, reduces waste of resources, increases energy usage, and encourages passive design strategies (Bynum et al., 2012).

In the design phase, the use of BIM can impact the project significantly because of its ability to influence costs is the highest. Before the problem becomes a high cost impacts to the project, the team can creatively come up with ideas and provide solutions to problems. This can be achieved through the cooperation and coordination



of the entire project staff. Therefore, it is very important to have good cooperation. The use of BIM has particularly enhanced the team's collaborative efforts. Architects and engineers can check their design concepts, including energy analysis (Hergunsel, 2011).

It is believed that BIM offers tools that can be used for all domains in project management by the stakeholders involved and during the entire project lifecycle (Oti and Tizani, 2015). A study done by Young et al. (2009) about the use of BIM in the construction industry. They mentioned that about 72% of BIM users stated that BIM has an impact on improving the project process, and 62% of these users adopt BIM on more than 30% of their projects.

Arayici et al. (2012) conducted a study about adopting and implementing BIM in remote construction projects. In their study, they delivered some evidences of how BIM can lead to reduce some challenges of remote construction projects such as efficient communication, managing procurement, appropriate scheduling and quantity take off, and providing understanding between stakeholders involved in the same remote construction project and located as different locations.

In general, based on the above literature, adopting BIM in construction project is necessary for enabling sustainable. However, there are some barriers to the use of BIM that are not stated in literature. This will be explained and reviewed in next section.

#### **3.4. Barriers to the Adoption of Building Information Modelling (BIM)**

BIM is a new phenomenon which aim to change the way of establishing construction industries, which in turn will make it hard to implement and adopt. Despite the fact that BIM is the solution of many construction problems, it is known that BIM does not come without challenges, this fact has been supported by (Ashcraft, 2008).

As mentioned by Bin Zakaria et al. (2013), the absence of knowledge and awareness, lack of government support, absence of BIM standards and guidelines are among the main barriers of BIM adoption in Malaysia. According to Nanajkar and Gao (2014) the cost of software, the steep learning curve and incompatibility issues among different software packages were perceived as the principal barriers to BIM adoption by Indian construction experts.

According to Chan (2014), the main barriers to the adoption of BIM are the lack of qualified in-house personnel, unavailability of training and education, absence of standards, and lack of client demand. In Nigeria, The major barriers to BIM adoption were described as the resistance to change in the industry, lack of training, education and cost associated with training, lack of support and involvement of the government (Abubakar et al., 2014).

Some barriers to the BIM implementation were also identified by (Ashcraft, 2008). The barriers are as follows:

- Standard of care of using BIM: this means that the professionals are unable to identify any physical conflicts (clash detection) that may occur throughout the buildings life cycle. This negligent may results in project delay and cost overrun, this is due to the rework required when clashes are detected.
- Design delegation and professional responsibility: This section looks at defining and identifying the responsibilities and roles of the parties included in the projects. The process between design, construct and ownership of the building normally puts the architect and engineer as the person with the most responsibility for the model. Alternatively, a new position such as a BIM-modeler can be developed to carry out the same responsibilities.
- Intellectual property: This is related to the challenges that will arise in terms of what is the design and who owns it amongst others. Such problems are only solved by contractual agreements at the commencement of the design process. Failure to do so may lead to violations because the model holds the parts of the design.
- Insurability: This is related to who has rights in the model of the project at hand. Hence the rights to the models must be insured. Insurance brokers involved in the construction industries are yet to allow stable and assured policies with regards to these issues.
- Data translation: this is related to the sharing, feeding and transferring of information into the model. The appropriate interoperability of the information is an essential aspect of BIM. The ability for different tools in the model to adequately send and receive information is of most importance. The

ethics of the professionals plays a role in ensuring the smooth-running of this part of the model.

### **3.5. Building Information Modelling (BIM) and Sustainability**

Sustainability refers to the ability to meet the needs of today without compromising the ability of future generations to meet their needs. Sustainable construction can be achieved by knowing how green the buildings are in term of materials and energy consumption starting from construction, usage maintenance and demolition. In addition, with the use of BIM materials selection can be improved, lead to better construction (Moakher and Pimplikar, 2012).

The American institute of architects defined sustainability as the ability of people to keep functioning into the future without being exhausted or overloaded of the key resources in which the systems depend on (Mendler and Odell, 2000). Sustainability brings better quality of life to everyone in way it achieve environmental, economic, and social goals at the same time (Rajendran and Goh, 2012).

Sustainable buildings are highly needed to ensure better environment, these buildings use materials which have less environmental impact throughout the buildings lifecycle. In this regard, the UK construction strategy until 2025 is to achieve 33% decrease in the total cost of buildings and 50% decrease in the total greenhouse gas emission (Cable and Higgins, 2013).

Building sustainability depends on various interrelated and interdepended components, these are affected by the design decisions made by carious participants of the project (Anastas and Zimmerman, 2003). Furthermore, determining the sustainability of buildings is a complex task by taking in account a variety of challenges to be tackled (Salihi, 2016). Rajendran et al. (2012) presented the main principles of sustainability in construction, these are:

- 1- Reduction in resource use.
- 2- Increase the reuse of resources.
- 3- Using renewable and recyclable resources
- 4- Keeping the environment protected.
- 5- Providing nontoxic and healthier environment.
- 6- Seeking quality in the built environment.

As mentioned by Bynum et al. (2012), the relation of BIM and sustainability is beginning to reach its potential because they are relatively new concepts in the AEC industry. Further, Azhar (2011) described of importance of BIM in sustainability in which BIM can be used to choose the orientation of buildings, assess different envelope alternatives, and conduct daylight analysis for its direction on the selected site during the early design stage, thus improving its sustainability.

According to Krygiel and Nies (2008), BIM can be used to assist in the following areas of sustainable design: Building orientation, building massing, day-lighting analysis, reducing water needs in the building, energy modelling, sustainable materials, site and logistics management. Moreover, Rajendran et al. (2012) said that BIM is the core of sustainable design approach for building performance simulation and analysis. It has been used for decision making and sustainable building performance analysis, such as water and energy analysis in the early design phase.

In order to measure the level of building sustainability, three major and important elements should be taken in account, these are, social, economic, and environmental, they usually become metrics to determine the success level of sustainability. Moreover, the impact and effectiveness of BIM on the building design process is based on three dimensions of sustainability (Soltani, 2016). Accordingly, the importance of BIM regarding sustainability dimensions including environmental, economic and social will be reviewed and studied in the following sections.

### **3.5.1. Economical sustainability**

Economical sustainability is considered to be one of the significant contributions of BIM to construction sectors. It has a direct role in the process of cost estimation and risk management (Hartmann et al., 2012). Further, using BIM in other aspects of buildings will also bring important impact on economic efficiency. For instance, guessing the projects detects, and promoting collaborations and communications between stakeholder's results in reducing wastes, saving time, encouraging project management, and finally reducing project cost.

According to Gibbs and O'Neill (2014), it is hard to quantify economical sustainability because there are few data about where the green economy is happening. But, it is well

known that using BIM reduces the total cycle cost of projects. As cited by (Lu et al., 2014), around 6.92% cost saving was achieved by using BIM in a sample projects.

### **3.5.2. Environmental sustainability**

In general environmental sustainability looks to reduce the amount of gas emitted from buildings and enhance the quality of life (Sassi, 2016). With the use of BIM, stakeholders such as engineers and designers can determine how the building is performing at the early design stage, accordingly, they can rapidly assess the available design options in order to make good decisions for better building design (Azhar et al., 2011).

One of the most important properties of BIM tools is that they can determine and analyze the energy and materials consumption, electrical and mechanical performance of buildings, thereby they can provide a well suited information on energy and resources waste reduction (Wong and Fan, 2013). With the use of BIM software such as Autodesk Revit and Ecotect, the environmental characteristic of any project can be calculated and analyzed. As a results, engineers and architects can determine the building energy use and use resources in an efficient way. This further enables architects and designer to manage energy usage and exploit resources efficiently, conduct a solar path analysis, orientation and shading, heating and cooling calculations. These software can provide efficient information for a well suited building design. Furthermore, BIM can improve spatial design, particularly evaluating building airflow and overall ecosystem (Bonenberg and Wei, 2015). BIM can also be utilized to imprison energy simulation and assess the possible environmental effect in the context of green evaluation (Al-Ghamdi and Bilec, 2015).

Generally, BIM technology leads to new way of prediction, management, and monitoring the impact of environment on projects. In addition, BIM provides an opportunity by the data rooted in buildings to enlarge its space in sustainability (Bynum et al., 2012).

### **3.5.3. Social sustainability**

Social sustainability is defined as the ability of people to live in a way that satisfy their requirements as well as the subsequent generation's requirements. In order to achieve social sustainability, it is necessary to consider the stakeholders needs (Almahmoud

and Doloi, 2015). Sustainability is not only about decreasing the environmental impacts of buildings, yet it also seeks to improve the social life of people living with the building and the economic activities related to these buildings are improved as well (Maliene and Malys, 2009).

In general, the benefits of social sustainability are based on the enhancements that lead to better human health, comfort, and well-being (Sassi, 2006). Furthermore, the social principle addresses a wide spectrum of concepts and definitions which can be divided into two groups in terms of interaction with BIM, dependent and independent features. Dependent features of the social sustainability are more quantitative and can directly be measured through other assessments which BIM can provide for various aspects of the environmental condition such as energy performance and lighting. It is also important to mention that, enhancing environmental sustainability bring health and performance promoting, while negative environment brings disorders such as stress and discomfort. Consequently, these considerations bring benefits to the entire community and society.

### **3.6. Energy Performance Simulation**

The global contribution from building including both commercial and residential toward energy use toward energy use has gradually increased reaching between 20% and 40% in developed countries and has exceeded the other major sectors: industrial and transportation (Pérez-Lombard et al., 2008). Thus, building energy simulation models were produced to determine the building energy performance and also to calculate the best energy cost systems (Kim and Woo, 2011).

According to a study done by Reeves et al. (2015), as a subset of BIM the American Institute of Architects (AIA) documented the various benefits achieved through the use of BEM by different stakeholders involved in energy efficient buildings. They went on by saying that, BEM allow the designers to achieves energy efficiency in buildings by adopting a performance based approach that offers less life cycle buildings costs including initial cost reduction, changing orders, maintenance and operations costs, in the meanwhile the building's occupants will be more comfortable and satisfied with their indoor environment.

Buildings thermal comfort and energy performance can be achieved and provided through the use of simulation tools. Particularly, these programs can improve understanding of building operations based on their specific factors and enable ways to compare different design models (Sheth, 2011). The efficiency and functionality of these models are greatly rely on the provided data. Whereas, an accurate simulation models may determine the real buildings performance. However, the obtained results might be having some errors and ambiguity, most of these program let the user to enter the default data based on unavailable simulation factors. That's why, the absence of accurate and appropriate data as well as the huge amount of assumptions made in the simulation may results in some flaws and mistakes in the outcomes (Kim and Woo, 2011).

### **3.6.1. BIM for improving building energy performance**

As people's awareness of environmental impacts and building energy consumption continues to increase, designers and architects need to think more about building sustainability and energy performance. To ensure that most of these considerations are reflected in building performance, key design decisions should be made by stakeholders at an early design stage. Therefore, the application of BIM in building energy simulation greatly enhances the energy analysis process, so this method has gained momentum. (Cho et al., 2012).

Building information modelling is considered as a rapidly evolving process to support building energy performance analysis is the building information model. Using appropriate building modeling methods, considering relevant engineering interdependencies, usually at an early stage to support the design process and related design experts, is the ambition of the EU with almost zero energy building (Samuel and Joseph-Akwara, 2015).

As mentioned by Reeves et al. (2015), using BIM for energy modelling has various benefits such as a precise and accurate energy analysis in the early design stage, enhanced life cycle cost analysis, and monitoring the actual building performance throughout its operation stage. Buildings energy efficiency need validation of performance which specifically done by using energy simulation tools.

BIM is steadily being used in buildings to improve the construction efficiency including renovation, energy simulation. For example, in UK the government made the use of BIM mandatory for all public projects since 2016, this is to decrease project wastage and monitor sustainability (Zhang et al., 2016). Thus, using BIM, energy modelling, and comprehensive coordination between design participants are highly needed for better performance not only for new projects but also for existing buildings as well (Cho et al., 2012).

### **3.6.2. Interoperability between BIM and energy simulation software**

To provide strong and correct data, there is a need to integrate BIM programs by its interoperability with other energy modelling programs. Energy performance and design tools should be able to correlate information, meet the expected data in the design and to be automatically updated. Accordingly, this cooperation will help the users to improve the construction process (Kumar, 2008).

As mentioned by Mirnoori (2013), the energy efficiency of building can be greatly enhanced through the combination of BIM (which helps the creation of the building models with attainable data) and ESS (which allows engineers and architects to solve and prove the energy data by conduction different simulation models). Hence both can help in promoting building performance and assist designers to design building more consciously with effective design decisions. Thus, interoperability, will let the users to enhance energy performance, at the same time necessary changes can be made in the early design stages. It will produce a clear, and better environment, and energy efficient projects.

Performance and energy analysis are specifically performed once the design of the building is completed. Thus, the absence of effective integration in the design process will leads to in effective process of retroactively adjusting the design to attain a couple of design criteria (Cho et al., 2012). The integration of these models are based on direct transfer of information among different programs, this type of exchange requires a certain model that can be shared by exchanging functions. Hence, it will be necessary to review the capabilities of various methods of exchanging information between BIM and energy simulation tools, which are greatly necessary for the stakeholders who want to export the design model and information from BIM to energy analysis software (Jalaei and Jrade, 2014).



According to Moon et al. (2011), both IFC (Industry Foundation Class) and gbXML (Green Building Extensible Markup Language) are developed to achieve the building models and information interoperability. IFC aims at bringing a widespread foundation to improve process and data sharing in projects and management industries. While gbXML which is formed by Green studio improves the exchanging data process between BIM and energy analysis tools. With the use of XML the human interferences for communicate information can be decreased greatly and also a detailed descriptions of one building of a couple of buildings can be transferred and used by energy simulation programs (Kumar, 2008).

### **3.6.3. Traditional design method vs performance based design method**

Engineering and architectural design is a duty of a large team including specialists such as engineers, architects, quantity surveyors, project managers. For the long time, the basis of the projects was and are 2D drawings (sections, plans, elevation) of designed building in a symbolic manner, in accordance with the principles accepted by all participants in this process. In the traditional design method, each of the specialists work on separate drawings (prepared on tracing papers) with only those elements for which they are responsible. The tracing papers which are produced by specialists are imposed on each other during the coordination meeting to check the compatibility of the project (Czmoch and Pękała, 2014).

To optimize and evaluate the building design and performance, various analysis and simulation should be part of an integrated building design process. This is the base of performance based design strategy. However, as mentioned by Aksamija and Mallasi (2010), this is an interesting pattern when compared to the traditional design method:

- Traditional design method has insufficiencies. This is because it includes simplified assumptions based on the rule of thumb which may be inaccurate, it also force aesthetic characteristics with no considerations of performance impact, and it does not make any performance evaluation for the available design solutions.
- The method of building performance based design is able to calculate the impact of any design solution as the building performance are examined based on as actual and quantifiable data and not rule of thumb. It also uses a detailed building models to analyze, simulate, and predict the behavior of the building

model. Finally, within this design method it is possible to evaluate multiple design alternatives.

With the development of BIM, using digital tools for buildings design significantly increased. However, the integration of decisions support information during the early design had been slightly used. Such integrations may enhance the design solutions by providing information of interactions and dependencies by describing the design space clearly including the dependency of energy performance on buildings design parameters. The exploration of design space would allow the designers to assess and evaluate their design using the simulation results and alternatives for better understandings of the determined results. This approach visualizes the impact of design changes, also it provides rapid results and it is integrated into a computer-aided design environment for guiding the designers through the design space in order to achieve efficient performance solutions (Ritter et al., 2015).

### **3.7. Autodesk Revit as a Building information modelling (BIM) tool**

Revit is one of BIM authoring tools that provide design capability for drawing elements and parametric modelling (Hardin, 2009). It was firstly familiarized in the AEC industry in 2002 by Auto Company, and then was widely used by many companies who were using BIM. Moreover, Revit can interface with other software and programs through DWF, DXF, DWG, IFC, and gbXML files (Chen and Gehrig, 2011).

Revit packages consist of three main applications which are Revit MEP, Revit structure, Revit architecture (Azhar et al, 2008). Revit structure is utilized for structural design and analysis using basic components modelling like walls and foundations by the structural. While, Revit architecture is used for buildings architectural design such as door, roof, and wall (Latiffi et al., 2013).

Revit Architecture help to capture and analyze the most innovative design concepts and maintain vision through documentation. The software provides information based models that help to make decision for sustainable designs, detecting clashes, planning and fabricating for constructions, also it encourages collaborative works among different participants such as engineers, contractors, and owners. In addition, the Computable Revit design model is ideal for the analysis required for sustainable

design. Once the walls, windows, roofs, floors and interior partitions of the building are developed, the Revit model can be used for the entire building analysis (Moakher and Pimplikar, 2012).

Barista (2012) demonstrates how Revit can be used in many green building environment projects and reports some benefits such as simulation processes, reduced project cost, reduced schedules, better project quality, improved materials distribution, better patient and staff mobility, and coordination between electrical and plumbing (MEP) activities. In addition, it was mentioned that Revit helped on-site coordination to solve the problems prior to construction, and MEP and labour costs were reduced by 20% due to fewer revisions and errors.

Some BIM software (such as Revit) provide some common tools to process information to analyze buildings environmental characteristics. This will help architects and designers to effectively manage energy use and resources, provide solar path, building location and orientation, shading design, and analysis of heating and cooling, such software can integrate data for a greener design (Wong and Fan, 2013).

### **3.7.1. Autodesk Revit (BIM) advantages**

As mentioned by Cumpton (2010), there many advantages of auto desk Revit, these are as follows:

- Automatic Renewing the Model

One of the basic feature of Revit is that it arranges in process when something changes in model. Thus, changing any parts or elements will be reflected to other connected parts in the model automatically.

- Parametric Change Management

It means keeping the 2D drawings updated that is integrated with 3D models in order to discover clashes during the design stages.

- 3D Modelling

3D modelling enables its users to zoom the required model elements to search for any details such as join sections with great resolution in case there is clashes in that part.

- Floor Plan Devices

With Revit, it is possible to generate a floor plan as critical section in the building documents.

- Sheets Organization

Based on the viewports' scale, the dimensions of comments, texts, and shape of hatches are automatically scaled. In addition, with Revit the plans, sections and elevation numbers are directly updates in the same time details are added to them.

- Managing time and cost

This covers cost estimation, bid management, contracts supervisions, field examination, changes administration, construction process check in accordance to scheduling and budget. All of these can be prepared by Revit after receiving the Bill of quantities.

- Parametric Families

In Auto cad, the objects will not be moved when the distances between object are changed. While, Revit support the relations between items, this means that when any changes are happened all the related items will be shifted.

- Working on a Single File

In Revit, all the information are saved in one single file.

- Interoperability in Projects

Revit support cooperative design work, in which all the related parties can work on the same file and provide their modifications.

- Accessibility to Different Design View

In Revit, it is possible to access to any view such as plans, elevations, and sections

### **3.7.2. Autodesk Revit (BIM) disadvantages**

Although there are many advantages of using Revit, there are other disadvantages for using it, the following are some disadvantages (Cumpton, 2010):

- 1- Lack of “Add-on” Feature: even though Revit is greatly used by architects and engineers, the absence of add on features make it not too applicable by MEP contractors.
- 2- Mistaken belief about Revit: there are many not true views about Revit such as:
  - Reduces efficiency during transitions.
  - Difficult to be used in small companies.
  - Only owners get benefits of it.
  - Existing of Interferences during the process.
  - It does not applies new methods.
- 3- Considerable expenditure and time-consuming: the time used for Revit training and changing the platform from Auto CAD to Revit are the major problem for small companies to use Revit.

### **3.8. Energy Simulation Software Tools**

Simulation can be defined as an imitation of some real things or process. The art of simulating something generally involves representing certain behaviors or key characteristics of a selected physical or abstract system (Ali et al., 2016).

BIM tools can be used to achieve sustainable design in which building materials information can be exported to various energy software's such as Green building studio, Ecotect, 3D studio max by using both gbXML and IFC (Sheth and Malsane, 2014).

Energy simulation software tools can be used by designers to reduce the cost of energy in buildings. It helps to accurately determine some variables that may allow designers to effective decisions about the best measures to be applied for any building. Moreover, designers need tools that answer to very specific questions during the early design stage. By using energy simulation software, designers can make specific choices in term of heating and cooling. They can also estimate the thermal behavior of buildings before their construction, making the best thermal retrofitting measures to adopt in the buildings under analysis (Sousa, 2012). Furthermore, rather that energy consumption, simulation software tools can also be used calculate to the following variables:

- Indoor temperatures.
- Heating and cooling energy requirements.
- HVAC systems energy consumption.
- The amount of natural lighting required by the occupants.
- Interior comfort of the inhabitants.
- The required ventilation level.

According to Charron and Athienitis (2006), today, there are many energy simulation programs available, with the use of these program the total building performance can be simulated. Some of the aspects that can be summarized as follow:

- The solar radiation in both building inside and outside.
- The energy consumption and level of comfort.
- The amount of air flows in buildings due to infiltration and mechanical and natural ventilation.
- Equipment, lighting and human loads.
- Renewable energy generation.
- HVAC system's behavior.
- Lighting controls and integrated shading devices.
- Environmental emissions.

Furthermore, it is possible to use energy tools in the design stage effectively to simulate what if scenarios in order to achieve the best solution. These scenarios can be used to assess the energy effects of:

- The shape and form of buildings.
- The orientation of buildings.
- The buildings envelopes materials.
- The type of glazing and placement.
- The type and efficient of HVAC systems.

In general, many energy simulation tools are in place. Thus, in this research some of the most important tools due to their ability to calculate a considerable amount of variables will be presented, and then will be compared to each other to study their differences and choose the most appropriate one.

### **3.8.1. Energy Plus**

Energy Plus is a new building performance simulation program that combines the best capabilities and features from BLAST and DOE-2 along with new capabilities (Crawley et al., 2001).

Energy Plus is a thermal simulation software tool that allows the analysis of energy throughout the building and the thermal load and it is used by engineers, architects and researchers to model the energy use and water use in buildings. This tool was developed in 1996 which sponsored by the Department of Energy (DOE) from United States of America (USA). Energy plus is one of the most common known energy simulation software tools. Energy Plus has the features and capabilities of BLAST and DOE-2, however is an entirely new software tool that combines the heat balance of BLAST with a generic HVAC system. The Energy Plus aims to develop and organize software tools in modules that can easily work together or separately. Moreover, it is important to outline that in Energy plus does not have a visual interface that allow users to see and concept the building. In this case third-party software tools, such and Design Builder need to be used (Sousa, 2012, September).

Energy plus simulation software include the following utilities: Energy Simulation, thermal design and analysis, Heating and cooling loads, Validation, Solar control, Overshadowing, Natural and artificial lighting, Life cycle assessment, Life cycle costing, Scheduling (Bahar et al., 2013).

### **3.8.2. Autodesk Ecotect**

Ecotect is an environmental analysis tool that helps designers simulate and analyze building performance. From the early days of architectural design, it covers a wide range of essential analytical functions and simulation details.

It represents the analysis of the design, with efficient 3D visualization methods and energy efficiency tools. In particular, some of its features include shading design and solar analysis, lighting analysis, acoustic analysis, thermal analysis, ventilation and airflow analysis, building codes and resource management (Kumar, 2008).

Ecotect is a comprehensive concept-to-detail sustainable design analysis tool, providing a wide range of simulation and analysis functionality on a single platform.

Revit-based design models can be exported to gbXML format and imported directly into Autodesk Ecotect Analysis for simulation and analysis throughout the design process (Moakher and Pimplikar, 2012).

Autodesk Ecotect Analysis is suitable for architect or designer to simulate the building performance in early design stage or conceptual massing. This is because it provides user-friendly interface and graphical result outputs which are suitable for visual presentation. It also allows for self-generated optimum shading design which assists architect or designer to determine the shading strategies during the design development stage (Lim, 2015).

As mentioned by Douglass (2011), Ecotect is a flexible tool that works as a stand-alone application and as a source of input for other energy simulation programs. In addition, with Ecotect, it is possible to design the buildings models or it can be transferred by using gbXML or DXF files. Various analysis can be done by Ecotect such as solar, thermal, lighting, acoustic, and cost analyses that are ideal for early design stage feedback (Figure 3.2).

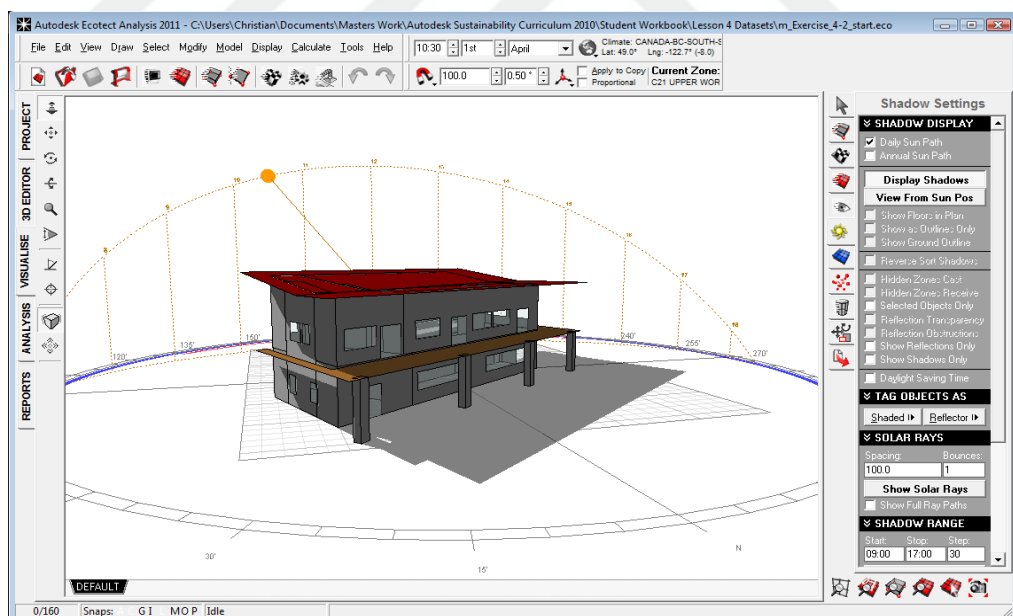

**Figure 0.2.** Sun path analysis in Ecotect (Douglass, 2011)

Ecotect includes a wide range of environmental analysis and simulation capabilities such as shadows and reflections, shading design, solar analysis, photovoltaic array sizing and load matching, lighting design, right-to-light analysis for neighboring



buildings, acoustic analysis, thermal analysis, and ventilation and airflow (Moakher and Pimplikar, 2012).

### **3.8.3. Autodesk Green Building Studio**

Green Building studio is known as a web based application that consist of buildings energy and environmental analysis tools. It can help the designers and architects to assess the carbon and energy profiles of different buildings design. these files can be shared between engineering software programs and between engineers and architects during the early design stage in which it help to make the building design more efficient and cost effective. This web service supports products in the architecture and building design family such as: Autodesk Ecotect Analysis, Autodesk Revit Architecture, Autodesk Revit MEP, AutoCAD Architecture, and AutoCAD MEP. It also can be used to achieve sustainable designs and environmentally responsible buildings (Moakher and Pimplikar, 2012).

As cited by Douglass (2011), Green building studio (GBS) is a web based services that adapt DOE-2 engine to conduct energy simulations. It can give information about the energy performance of buildings, carbon emission, water consumption, cost of materials, and more. Many design alternatives can be examined to make a quick decisions. Within this tool, building design parameters can be altered easily, and it is simpler than other energy simulation tools.

As stated by Abanda and Byers (2016), it is possible to use Green Building Studio to study the effects of buildings orientation, this is due to the fact that, numerous orientation can be examined and studied without the need to go back to the original geometry model. Within this tool, it is possible to determine the total building energy performance including electrical energy use, fuel use, and carbon emission.

Moakher and Pimplikar (2012), summarized the features of green building studio, these are as follows:

- 1- Energy and Carbon Results:** one feature of this web tool is that it provides detailed information about the buildings energy performance and resource use for many scenarios in which it help to compare them in the early design stage.
- 2- Whole Building Energy Analysis:** by using Green Building Studio, the total energy use and carbon emission can be calculated and decreased. In this tool,

the annual energy consumption including electrical and fuels, is divided into lighting, HVAC system, and other equipment. Further breakdowns of energy use for major electric and gas end users—such as lighting, HVAC, and space heating—are provided in graphical format. Percentages associated with each category can be seen by clicking on the pie charts with your mouse.

- 3- Carbon Emission Reporting:** it is also possible to calculate the carbon dioxide emissions for all building aspects such as on site fuel use and emissions at power plant that provide electricity to the buildings. The power plants that generate electricity to the electric grid that serves the building are also summarized by their fuel type.
- 4- Photovoltaic Potential:** with GBS it possible to calculate for the photovoltaic energy generation. If the PV panels are installed on the building surface, then ever exterior surface on the building is analyzed to determine the amount of electricity that could be generated. A high-level summary of the building's photovoltaic electricity potential is provided.

Green building studio (GBS) includes the following utilities: environmental Design, thermal analysis, annual energy consumption (electric and gas), Carbon emissions, day lighting, water usage and cost, life cycle costing, natural ventilation (Bahar et al., 2013).

#### **3.8.4. Integrated Environmental Solutions – Virtual Environment (VE)**

This program was provided by Glasgow-based Integrated Environmental Solutions (IES) Ltd in 1994. It is considered to be a very strong energy tool as a wide range of design analysis can be provided. It allows the designers to design and import models in which they represent the actual buildings designs (Figure 3.3). In addition, users can easily adjust the design, control position, specify space's usage and materials, and calculate for the HVAC system. All of these capabilities help design teams to integrate sustainability and environmental solutions in the early design process (Ayyad, 2011).

There are many simulation engines in IES <VE> that enable an accurate and complete simulations such as CFD and energy performance. Thus, one building model can be examined for various simulations. Most of the performances in Radiance are available in IES <VE> such as simulating illuminance, luminance, daylight factor and glare

index under various CIE sky conditions. Although CFD is available in IES <VE>, its application is limited to simple geometry and less detailed modeling (Lim, 2015). Moreover, this tool allows direct connectivity to Sketch Up, Revit and Archi CAD through the import of gbXML and DXF models (Attia, 2011).

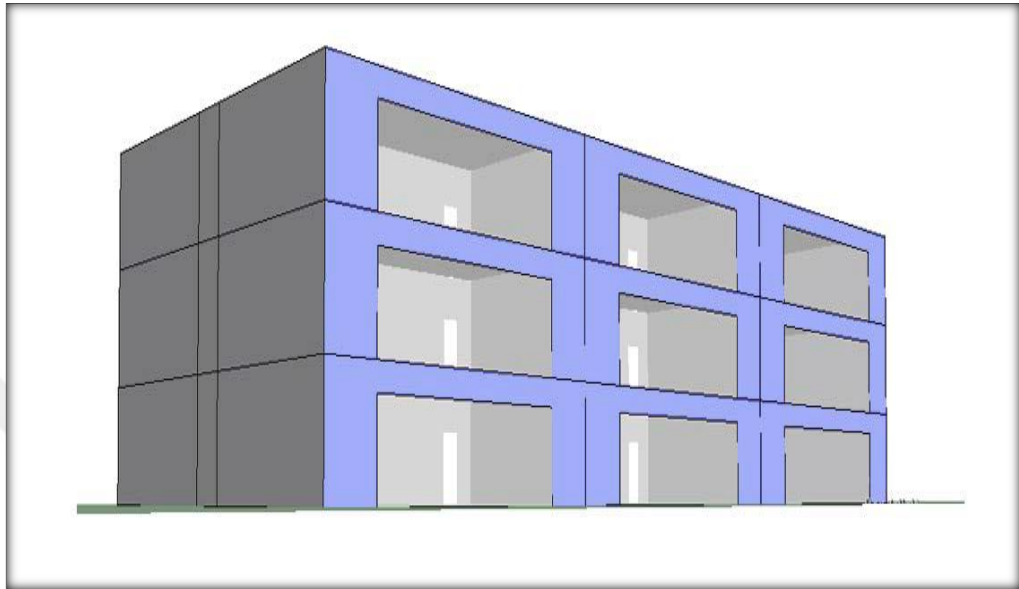

**Figure 3.3.** A perspective view of office building in IES (Ayyad, 2011)

According to Bahar et al. (2013), IES <VE> software includes the following utilities: Thermal design and analysis, heating and cooling loads, CO<sub>2</sub>, Validation, Solar, Shading, Lighting, Airflow, Life cycle costing, Scheduling, fire evacuation.

### **3.8.5. E-Quest**

E-Quest is one of the most commonly known simulation tools that is free and available to the public. It is an interface that uses DOE-2 as its simulation engine. It can be utilized by designers, operators, owners, energy and LEED consultants, professionals, and researchers and universities (Douglass, 2011).

One of the most significant advantage of this tool is the ability to adopt three different level of user's expertise. For beginners, they can create a schematic plan through the use of simple input data (Figure 3.4). The design development wizard allows a greater level of input for more intermediate users, and for advanced users, the detailed mode allows the manipulation of all building parameters. With E-Quest single, multiple, and parametric studies can be conducted. The disadvantages of this program are simplified models for ground connections, infiltration, natural ventilation, and

daylighting can only be examined for curved surfaces and cannot transmit through interior glazed surfaces (Douglass, 2011). E-Quest includes the following utilities: Energy performance, simulation, energy use analysis, conceptual design performance analysis, 3D Model (3D Design), thermal design and analysis, heating and cooling loads, Solar control, overshadowing, Lighting system, life cycle assessment, life cycle costing, Scheduling (Bahar et al., 2013).

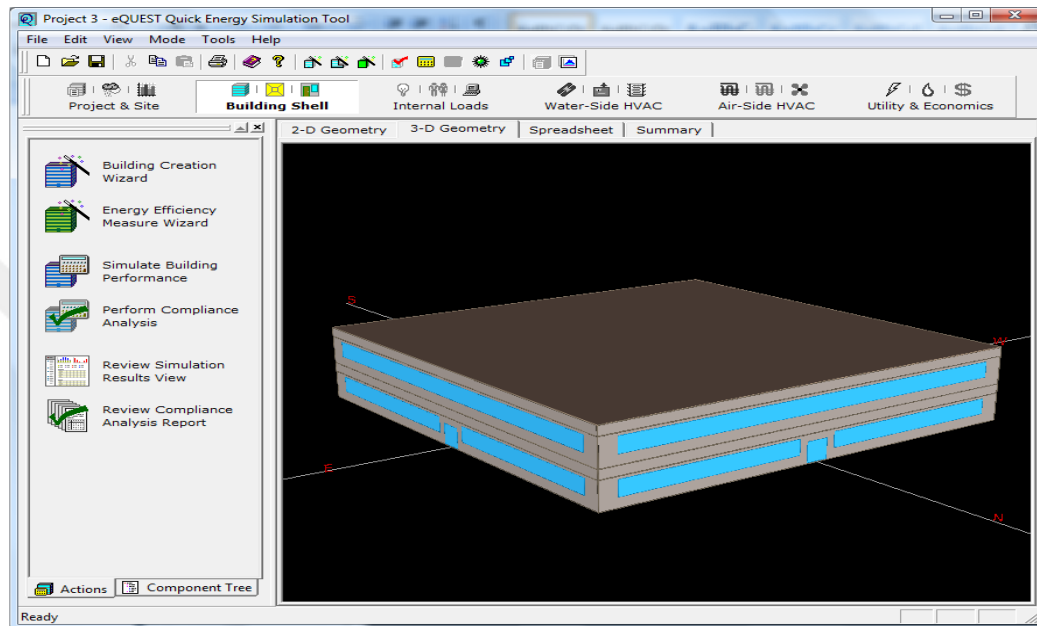

**Figure 3.4.** An example of two story building in e Quest (Douglass, 2011)

### 3.8.6. Design Builder

Design builder is another integrated and simulation software which enables one single modelling for numerous simulations. This simulation tool was developed by the US energy department on development experiences with two previous programs DOE-2 and BLAST. This tool uses Energy plus which is highly accurate and accepted simulation tool for both thermal and energy simulation (Loutzenhiser et al., 2007) and (Crawley et al., 2001). In addition, it utilizes radiance as daylighting simulation but with limited performance, also luminance and glare are not available in this tool. That's why it is not used for daylighting studies. Furthermore, for CFD analysis Design builder provides more details when compared to IES <VE>. Design Builder CFD gives more detailed analysis in comparison with IES <VE>. With design builder, external and internal airflow analysis can be simulated and examined in the same time.

As cited by Bahar et al. (2013), Design Builder was typically established around Energy Plus, enabling the input of glazing and fabric data of Energy plus, building models for energy simulations, and allowing compliance with UK's energy certificates and comparing and analyzing of different design parameters. It is also mentioned that Design builder can performance many environmental and lighting simulation and analysis. In term of interoperability, the created 3D models in Revit, Archi CAD, and other CAD systems can be imported in Design Builder by using gbXML and DXF files. This is also supported by Attia (2011), who mentioned that Design Builder provides interoperability with BIM models through gbXML, this allows importing 3D building models created in Revit or Archi CAD. (Douglass, 2011) also stated that, buildings geometry can be created by using Design Builder or it can be transferred from any architectural program by using gbXML (Figure 3.5), and changes can be made to the building, buildings blocks, and single thermal zone through the data inheritance.

Design builder includes the following utilities: design of environment, 3D designs, thermal design and analysis, heating and cooling loads, natural and artificial lightings, internal air, mean radiant and operative temperatures, humidity, CO<sub>2</sub> emissions, solar shading, and heat transmissions (Bahar et al., 2013).

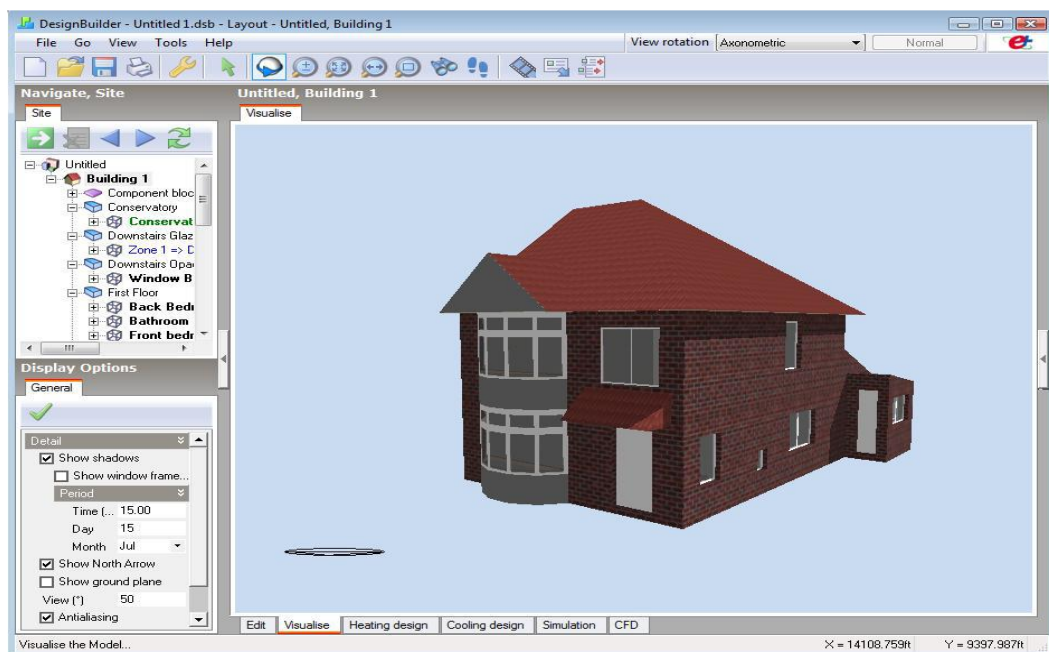

**Figure 3.5.** An example of residential building geometry shown in design builder (Douglass, 2011)

### **3.9. Conclusion**

In this chapter, an attempt has been made to outline the importance of BIM and its implementations in construction projects. The obstacles to BIM implementation was also documented. The ability of BIM in ensuring sustainability was highlighted. A comparison between the traditional design method and performance-based design method were also documented. Autodesk Revit as a BIM tool, and its advantages and disadvantages were also reviewed. Finally, several energy simulation software and their application areas were identified and the key benefits for each one of them were highlighted.



## **CHAPTER 4**

### **RESEARCH METHODOLOGY AND DESIGN**

Once a literature review is conducted, research methodology is developed. There are several methodologies that can be used in a research. Choosing one method over another will depend on the skill of the researcher and understanding how an individual method fits into the goals and objectives set by his/her research.

In this study the onion methodology developed by Saunders et al (2009) is adopted, because it is a good structured guide starting from philosophy to collection of data and analysis. All the components of the selected methodology are presented in the following sections. Then, the research is developed by selecting the most proper elements from the onion methodology. This is to and then the research is designed by choosing the most appropriate element from the onion methodology to deliver understanding and insights on how the study will be conducted from collection of data to analysis methods.

#### **4.1. Research Methodology**

Research methodology can be defined as a process of a systematic and methodical inquires and investigations to increase knowledge. It covers the whole range from the theoretical foundation to the data collection and analysis, making decision and result better than those based personal favorite (Collis and Hussey, 2014).

In order to describe the choices that have to be made for creating an effective research methodology, Saunders et al. (2009) established the research onion. It can be used to organize the research through 6 layers, these are philosophy, approach, strategy, choices, time horizon, and technique and procedure. This is to clearly demonstrate the research process that researchers can easily understand. The six layers of the research onion are shown in figure 4.1 and will be explained and presented in details in sections 4.1.1 to 4.1.6.

### 4.1.1. Research philosophy

The first and external layer in the onion methodology model, presents the research philosophy figure 4.1. It is an essential layer that is associated with developing of knowledge and nature of it (Saunders et al., 2009).

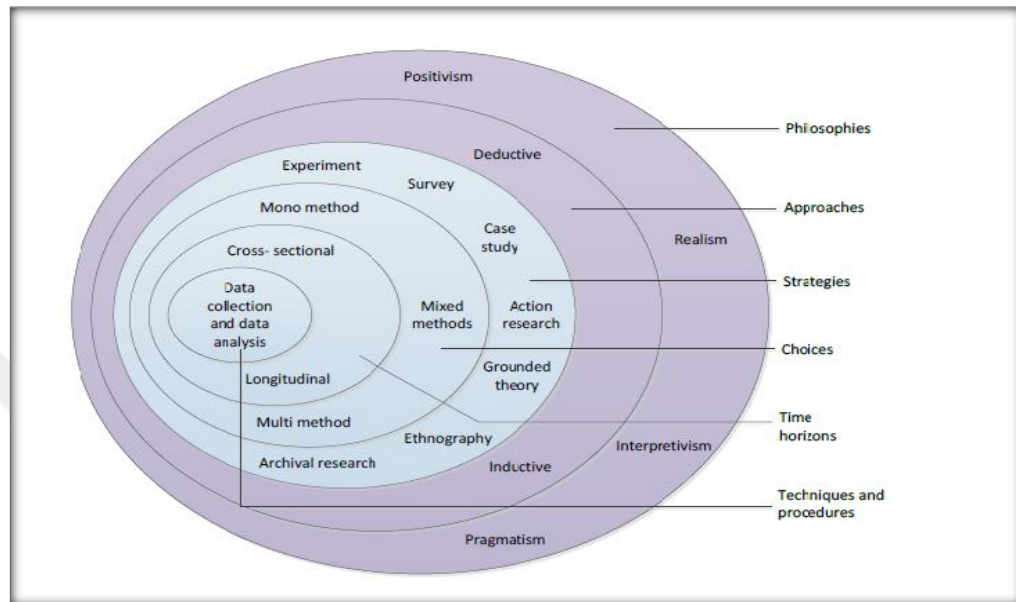

**Figure 4.1.** Research onion methodology (Saunders et al., 2009)

The research philosophy is an idea or a belief about collecting, interpreting, and analyzing the collected data. There are many types of philosophies that are presented in onion methodology set by sounders (Saunders et al., 2007). For each one of them, there is a specific method and assumption to illustrate the world and each philosophy has its methods and assumptions to explain the world and address a piece of research. Furthermore, the serious concern is not whether our research should be philosophically informed, rather it is about how good we are capable to reflect onto our philosophical selections and defend them among the many alternatives that we could have adopted. Nevertheless, it is mentioned that the methods and assumption do not a play a role in choosing one philosophy over another. But, the most significant thing is the researcher's understanding regarding the relationship between the created knowledge and the adopted process (Saunders et al., 2009).

Generally, there are four philosophies which are positivism, realism, interpretivism, and pragmatism (Saunders et al., 2009). Therefore, in this section all mentioned



philosophies will be presented to build up a better understanding of each one of them. This will allow to understand and select the most appropriate research design.

- 1- Positivism: it claims that reality contains of what is observed by senses that reality consists of what is perceived by the senses and it is possible to measure the reality by conducting scientific approaches (Collis and Hussey, 2014). The results within this philosophy can be easily generalizable to create a theory (Saunders et al., 2009).
- 2- Interpretivism: this philosophy argues that the research may not deal with subjects and objects in a similar way as positivism philosophy does. It seeks to explore the social reality of humans as social actors, and this is important to the researcher to be empathetic with the studied subjects to gain and that it is essential to the researcher to be empathetic with the studied subject to obtain access to its reality. Accordingly, the study may change according to the researcher feeling during the process (Saunders et al., 2009).
- 3- Realism: according to Gray (2013), within this approach the world exists and acts individually of the observer. As mentioned by Saunders et al. (2009), there are two types of realism philosophy which are direct realism and critical realism. The first one says that what is observed by sense such as listening, vision, taste, and touch is the real world. Conversely, critical realism declares that sense can capture a prediction of the cognition and consciousness (Saunders et al., 2009).
- 4- Pragmatism: according to Creswell (2007), this approach is not restricted to any philosophical systems, rather it is concentrated on the problem to be managed and the question to be asked. By adopting this approach, the researcher will be able to use any technique or method that achieve their main needs. This philosophy says that the research question is the most significant determinant of the ontology, epistemology, and axiology you adopt in the research (Saunders et al., 2009). One may be more suitable over the others to answer a specific question. Furthermore, in case the research question does not clearly refers to either positivism or interpretivism philosophy. Then,

pragmatism philosophy could be the perfect choice to cope with variation in your ontology, epistemology, and axiology.

Beside choosing a philosophy to guide the research, it is also necessary to make a few assumptions regarding some issues there is also a need to set a stance and make some assumptions about some issues for example the nature of data (ontology), the relationship between the researcher and the subject (epistemology), the role of values in the study (axiology). These assumptions will be considered because of their importance as presented in the literature (Saunders et al., 2009). The major assumptions are described below:

- 1- Ontology: is concerned with nature of reality. This will raise a question regarding the assumptions the researcher have about how the world is operating and the commitment made for a specific view (Sounder et al, 2009). It's also stated that ontology redefines the reality presented by interpretivism as well as positivism. According to Collins and Hussey (2014), positivism proposes that reality acts independently and externally of the researcher. On the other hand, the interpretivism describes the reality as a social phenomenon that is created by the observer's understanding and perception.
- 2- Epistemology: deals with the researcher's view about what establishes an adequate knowledge (Saunders et al., 2009). It makes the philosophical background available for the researcher to provide the researcher with a philosophical background in order to pick what kind of knowledge is acceptable and usable. It integrates and reinterprets the knowledge obtained from interpretivism and positivism philosophy. As mentioned by Collins and Hussey (2014) with epistemology, positivism's knowledge is objective and independent. On the other hand, interpretivism is subjective and created on internal belief. In regard to epistemology, positivism's knowledge is independent and objective, while interpretivism is subjective and built on internal beliefs.
- 3- Axiology: is concerned with studying judgements about values. Even though this may contain values we possess in the field of aesthetics and ethics (Saunders et al., 2009). This type of philosophy says that positivism is a value

free which means that the researcher is totally independent of the investigation. While with interpretivism, the researchers are able to adjust the values in the research (Collins and Hussey, 2014).

#### 4.1.2. Research approach

It comes on the second layer of the research onion (see figure 4.1). It introduces the research theory for the upcoming orders of each stage in the framework adopted in the research design. There are two types of research approach, deductive and inductive approach, each one them has its own way for collecting data. That's why it is quite significant to select appropriate approach to obtain the expected results (Saunders et al., 2009).

##### 4.1.2.1. Deduction

According to (Creswell, 2014), deduction start at setting a theory and move towards data. This is to realize the cause effect relationships of various phenomena (see figure 4.2).

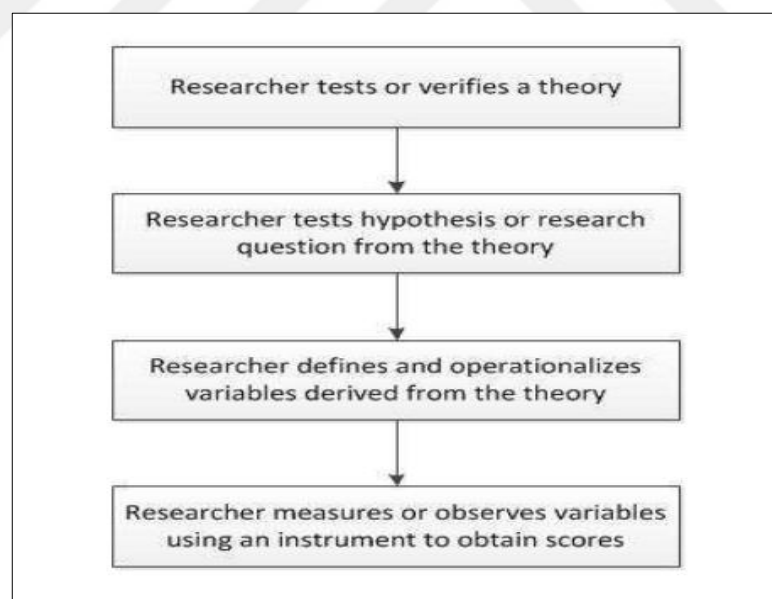

**Figure 4.2.** The deductive approach (Creswell, 2014)

Before using this approach, it's important to know that we need to create a theory and hypothesis. In this context, the researcher have to be detached of what is being observed. Adopting deduction approach will lead the researcher to develop a research strategy that will be utilized to check a research question or a hypothesis sat before. After that, the researcher will define some parameters in order to control the hypothesis

and then, to determine and analyze the results of the tests. In case the results are inconsistent with the proposed hypothesis, then the test is failed. Then the test is failed. Deductive approach is usually used with quantitative studies. This approach require a well-structured methodology and too many number of samples in order to be statically important and acceptable (Saunders et al., 2009).

#### 4.1.2.2. Induction

Creswell (2014) mentioned that, the induction process works opposite of deduction approach, it starts from collecting data and then the collected data will be analyzed to find out any relationship between the phenomena to finally create or generalize a theory (see figure 4.3).

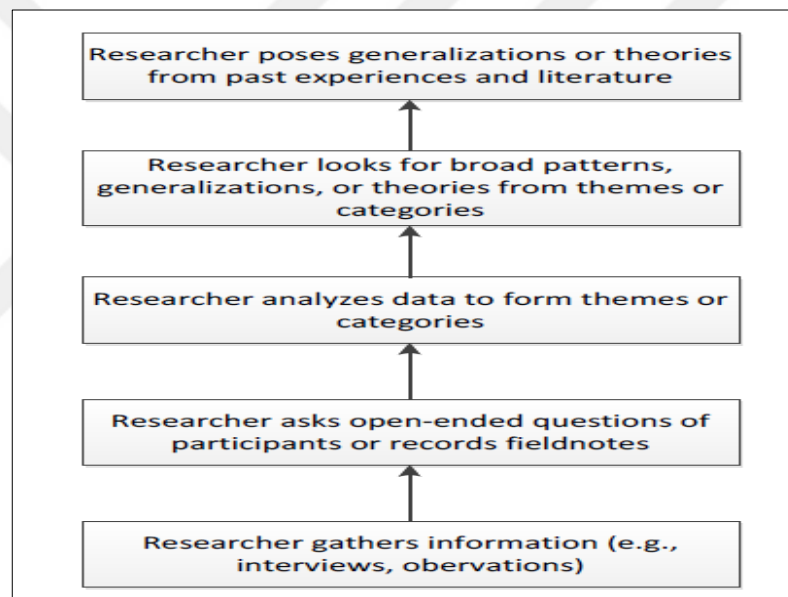

**Figure 4.3.** The induction approach (Creswell, 2014)

This approach concentrate on presenting the space in which a problem occurs more than focusing on the problem itself. For instance, if the researchers want to know why something happened more than knowing what is happened, then it's better to adopt an inductive research approach (Saunders et al., 2009).

#### 4.1.3. Research strategy

Research strategy comes on the third layer in the research onion. It is the plan in which the researcher will adopt to answer the research questions. It is about the different ways of strategies that the researcher will undertake for a specific study. There are seven

types of strategies which are experiment, survey, action research, case study, grounded theory, ethnography, and archival research strategy (Saunders et al., 2009).

#### **4.1.3.1. Experiment**

It is a type of research in which it is greatly related to natural sciences, even though it has a strong characteristics in numerous social science researches, especially in psychology. This type of strategy seeks to study the causal links, whether a variation in an independent variables will result a change in other dependent variables or not. Experiment strategy is usually adopted for both exploratory and explanatory approached to answer questions such as how, why, when questions in fields such as medical and psychology researchers (Saunders et al., 2009). Furthermore, this methodology is generally used in laboratories where developed in laboratory where most variables can be controlled. As a results, the outcome can have a high degree of accuracy and the findings definitely can be generalized to similar field studies.

#### **4.1.3.2. Survey**

This methodology is generally undertaken with deduction approach. Moreover, it is usually used in studies such as business and management. One of the most important characteristic of this strategy is that it is usually used to give answers of where, what, how many, who, and how much questions. Thus, it is suitable for studies such as descriptive and exploratory researches, it also enables for a great amount of data collection from a sizable population in a very economical way (Saunders et al., 2009). Many tools can be used for data collection such as interviews, questionnaires, and observation tolls (Robson, 2011).

#### **4.1.3.3. Case study**

This type of strategy more focuses on understanding a specific existing phenomena in a real context, which focuses on understanding a particular contemporary phenomenon within a real context using various evidence. It is usually used in both explanatory and exploratory researches study (Saunders et al., 2009). This strategy is more beneficial for studies where there is a few theories and there is a need to study a specific phenomenon (Collins & Hussey, 2014). Moreover, case study strategy usually is considered for both qualitative and qualitative (Robson, 2011). Within this strategy a lot of questions can be answered such as why, what, and how questions. Data can be

collected by using several ways and techniques such as observation, interview, document analysis, and questionnaires (Saunders et al., 2009). One important thing to mention about this strategy is that it is not possible to generalize the findings for similar studies occurring in other places. Moreover, it is necessary to generate a great amount of data for the purpose of making (Easterby-Smith et al., 2012).

#### 4.1.3.4. Action research

Action research is an iterative process concentrates on finding out as well as analyzing the problems within organizations. Solutions are suggested, proposed, and applied, the effectiveness of the suggested solutions are evaluated and then the cycle begins a gain (see figure 4.4). To successfully use this strategy there is a need to involve all the participants in a collaborative manner with the researchers (Saunders et al., 2009).

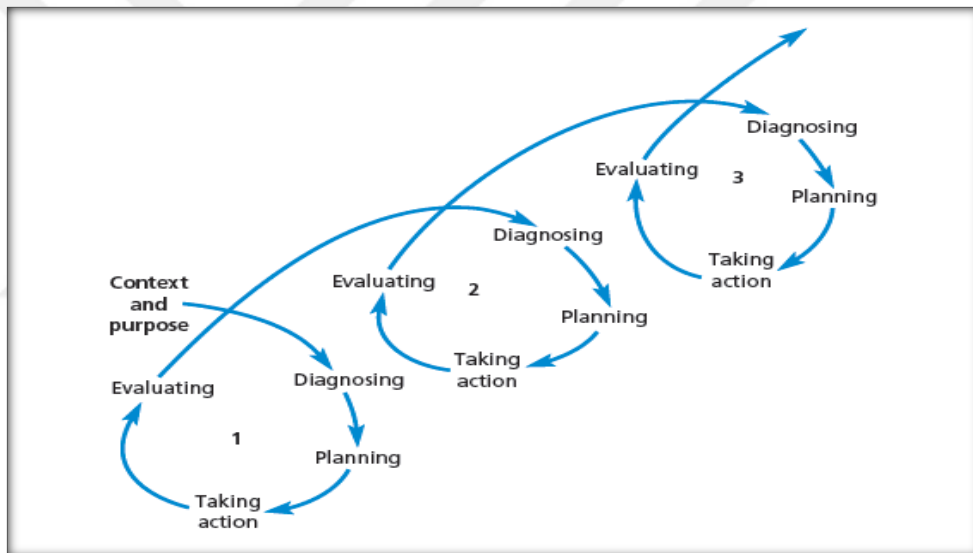

**Figure 4.4.** Action research process (Saunders et al., 2009)

#### 4.1.3.5. Grounded theory

Regarding this strategy, data are collected without the need to develop an original and theoretical framework. Theory can be established from the obtained data by making series of observations. Then, predictions can be made based on the gained data which are then studied and examined by using more observations that may agree or not the predictions. Grounded theory is a deductive/ inductive approach, theories being grounded in such repeated reference to the data (Saunders et al., 2009).

#### **4.1.3.6. Ethnography**

This strategy is firmly rooted in inductive method. It comes from the field of anthropology. The purpose of this strategy is to present and explain the social world in which the research objects are located, and to describe and explain them. It is clearly consume a lot of time because the researcher need to engage himself in the social world that is being studied as much as possible (Saunders et al., 2009).

#### **4.1.3.7. Archival research**

Within this strategy, the data collection is usually based on using administrative documents and records. It may use different approaches such as exploratory, descriptive and explanatory approaches for the purpose of answering questions about the past (Saunders et al., 2009).

#### **4.1.4. Research choice**

Research choice is the forth layer in the research onion. It can either quantitate, qualitative or multiple research methods (Saunders et al., 2009).

##### **4.1.4.1. Quantitative research**

Quantitative research is mostly used for any data collection technique such as questionnaire or for analyzing data such as graphs and statistics that establishes numerical data (Saunders et al., 2009). As mentioned by Gray (2013), experiment and survey research strategies are usually used with this approach. They can develop group properties and general tendencies" results which can be generalized to other research groups.

##### **4.1.4.2. Qualitative research**

This method in not created on a unified theory. It is used to explore and understand the context of a problem. Within this approach, the research process focuses on assumptions and questions. For this type of research, the collected data can be as texts or images that are gathered from different sources such as interview, observation, focus group and document analysis (Creswell, 2014). Qualitative research is mostly used for any data collection technique such as an interviews or for data analysis such as categorizing data that establishes non numerical data (Saunders et al., 2009). As stated

by Gray (2013), research strategies such as ethnography, grounded theories, case studies, action researches and archival researches are usually considered as a qualitative strategies. Any of these approaches is especially suitable to obtain knowledge in field areas where there are limited information and the researcher seeks to study and understand the phenomena where they happen.

#### 4.1.4.3. Multiple methods

According to Creswell (2014), multiple methods use both quantitative and qualitative techniques for the purpose of integrating philosophical assumptions and theoretical framework in the same research (see figure 4.5).

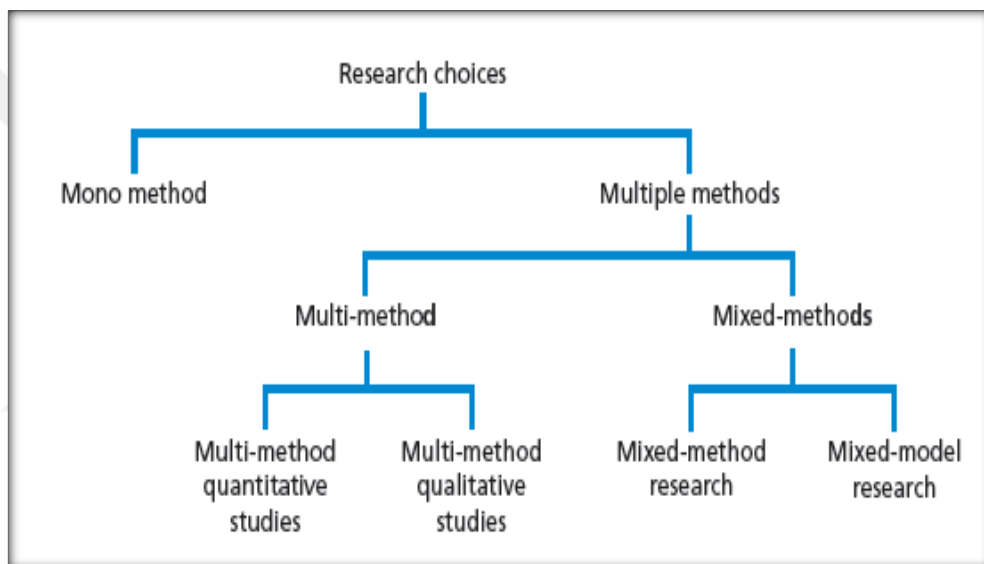

**Figure 4.5.** Research choice (Saunders et al., 2009)

According to Saunders et al. (2009), there are two types of this method:

- 1- Mono methods: this method uses only single data collection technique either quantitative techniques (surveys and experiments) together with analysis technique or a qualitative data collection method.
- 2- Multiple methods: within these methods, more than one technique are used for collecting data (qualitative and quantitative). However, there is a restriction to one of these techniques.

#### 4.1.5. Time horizons

As mentioned by Saunders et al. (2009), the time horizons can be classified into two types which are cross sectional and longitudinal time horizons. Cross-sectional time



horizon means that data gathering and collecting happen in one single time. The collected data are studied in a brief time. While longitudinal time horizon means that the data are gathered in many times, which in turn will help the researcher to study the changes over times.

#### 4.1.6. Technique and procedure

Since, there are many technologies and procedures based on research design, additional details and information will be presented in the next section that will help this research to be defined.

### 4.2. Research Design

In the first part, the researchers introduced the main concepts and ideas of the research methods. In the second part the researcher will take the mentioned above ideas to develop a research design. But, it is first necessary to make a review for the goals and objectives that are sat out previously in chapter 1 with the purpose of keeping in mind the major features of the research design required to accomplish the suggested goals. Figure 4.6 shows the elements considered in the research design.

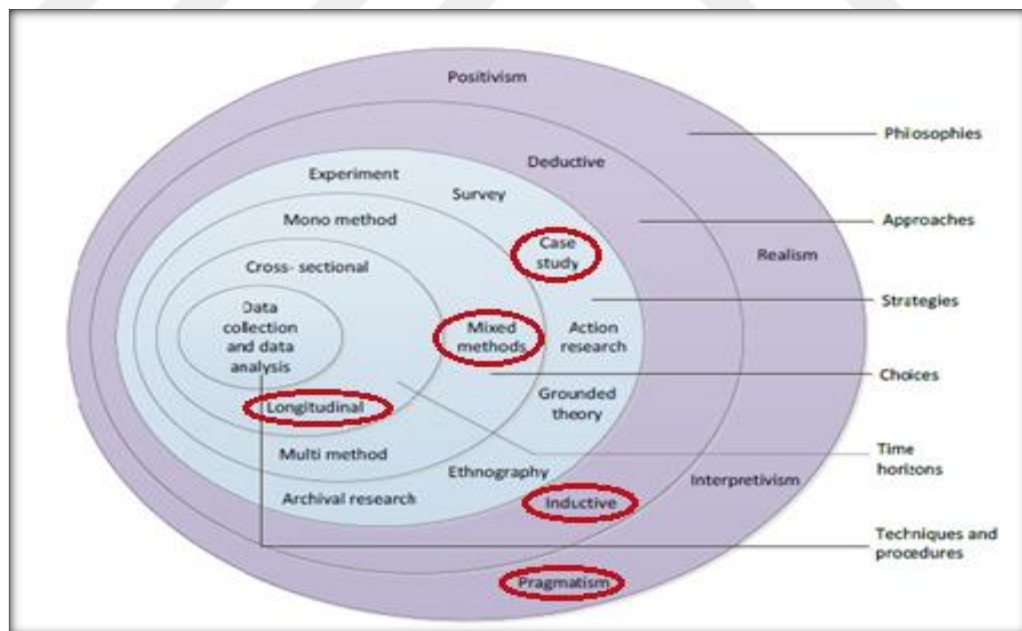

**Figure 4.6.** Research design

As shown in figure 4.6, in this research, pragmatism will be adopted as its philosophy, inductive as its approach, case study as its strategy, mixed methods as its choice, and finally longitudinal as its time horizon.

#### **4.2.1. Research philosophy**

To choose an appropriate philosophy, it is necessary to make a review for the goals and objectives set previously in chapter 1. The main question set in chapter 1 was the following:

*What is the holistic design approach for the performance based design and optimization through integrated BIM use in Turkey?*

To draw up the research design, it is necessary to select the purpose of the research and this depends on the way the researcher might answer the stated question. As mentioned by Saunders et al. (2011), an exploratory research will be appropriate to find out many things such as understand what happening, seeking new insight is, and asking question and assessing phenomena in new lights. Similarly, explorative research will be also useful as it aligns with the objectives set previously in which they are related to explore and discover concepts and to identify challenges.

After the purpose of the research is chosen and selected, in the following step the most appropriate philosophy will be chosen. As mentioned before there are four main philosophies which are positivism, interpretivism, realism, and pragmatism. According to Saunders et al. (2009), positivism methods can handle quantitative data, also Robson (2011) said that, positivism deals with high structured methods and produce a quantitative data. Conversely, exploratory study produces non numerical data (qualitative). In this case, there are no relation between the needed data and developed data.

Interpretivism cannot be used in this research, this is due to the fact that it is about how the social world is understood the studied subjects. That's why, the scope of this research is not applicable in this study. Realism is another philosophy which is not applicable in this research. Realism is a subject of interests in practice and value based professions like social work (Robson, 2011).

Pragmatism is the best philosophy to be used when the study is not appropriate for both positivism and interpretivism (Saunders et al., 2009). Within pragmatism philosophy the research will focus on the research questions more than focusing on a philosophy with a typical set of data collection tool. Thus, the research will be totally flexible, and the researcher are free to select any method for collecting data (Collins

and Hussey, 2014). Certainly, with pragmatism research, it is possible to deal with quantitative and qualitative data. Based on the facts mentioned above, pragmatism philosophy is considered to be the most suitable one as it allows focusing on the research question and gives the needed flexibility to discover and explore the context of the issues and to develop knowledge.

#### **4.2.2. Research approach**

In the earlier section, it's mentioned that the researcher in his study will study an area where there is an absence of knowledge namely a strategic BIM based design and optimization framework for energy efficient building design in Turkey. This is very important to select the research approach that will lead the process of the research as well as defines whether the research will start from a general or specific pattern.

As mentioned by Creswell (2014), inductivism is adopted where there is an absence of knowledge, and this is the case that has been set in the research questions and objectives. Thus, an inductive approach will be used in this research to deal with the research questions and type of data. This approach moves from collecting data to generalizing a theory or law. Similarly, this study will start from collecting data to describing the context of the current energy performance of buildings.

#### **4.2.3. Research strategy**

In this research, a case study approach will be used as a strategy for this research, this is because of its features that can handle all the challenges set by the research questions and objectives. This strategy also allows focusing on the research question and going deep in investigations. Furthermore, a case study research is usually used when there is no or limited theories or knowledge. Moreover, the flexibility needed in this research can be achieved by using this method as it deals with many types of questions such as what, which, and how questions and to build quantitative and qualitative data (Saunders et al, 2009).

#### **4.2.4. Research choice**

In this research, a mixed method study is chosen as a research choice. In other words, two methods were used for data collection at one time.

#### 4.2.5. Time horizons

The type of time horizon adopted by the researcher is longitudinal time horizon. This will allow the researcher to examine the changes over time. Thus, it would be probable to explain what is happening from an examination of the process of changes and patterns. In this research, multi case study buildings are adopted to study the dynamics of the problem. This is done by examining the same situation multiple times and continuously over the period in which the problem runs its course. Repeated observations were made to reveal the relative stability of the phenomenon.

#### 4.2.6. Technique and procedure

As mentioned by Creswell (2007), there are multiple methods to conduct a case study researches. As mentioned by (Stake, 1995), there are multiple methods in which all of them share common elements such as identifying cases, collecting data, and interpretations. This research will use the procedure set by (yin, 2014). This procedure has three stages (see figure 4.7):

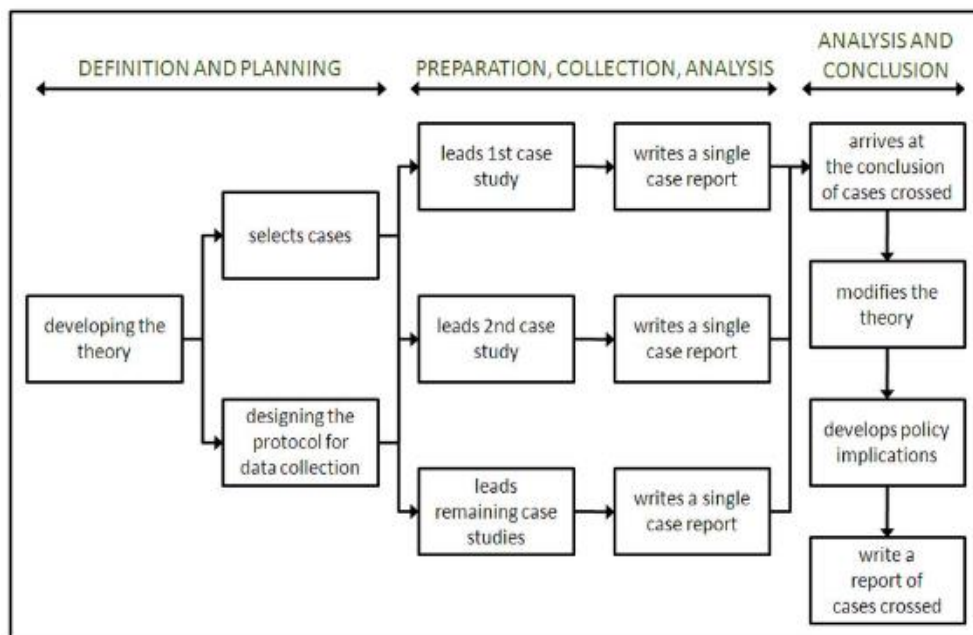

**Figure 4.7.** Case study procedure (Yin, 2014)

1-Definition and design: it is an important stage in any research. In this stage, the research question, aim, and objectives to be achieved are identified (Stake, 1995). These data will help in knowing whether the research is suitable to be answered by using a case study. In the meanwhile, the type of the case will be selected, whether it

is single, holistic or multiple cases. Moreover, a proper method for data collection will be chosen.

2-Preparation, collection, analysis: in this stage all the supporting activities is developed including creating protocol, accessing data agreement, and ethical issues. Then, the data are gathered, and analyzed (Gray, 2013).

3-Analysing and concluding: in this stage, a suitable analysis method is chosen to study the case study outcomes and then the results are written up.

In this section, all the procedure's stages mentioned by (Yin, 2014) are explained. Thus, in the following sections the assumption to be made and the way in which this research is developed will be explained.

#### **4.2.6.1. Defining and designing**

- Develop theory: this is already has been undertaken previously in chapter 1, where the research questions, research aim, and research objectives have been developed. They will integrate the theory that leads the research.

- Select cases: this is about the number and units of analysis to be adopted in the research (Gray, 2014). Generally, there are four types of cases which are as follows (Yin, 2014):

- Single case, holistic: This examines a single case as a whole or as a single unit of analysis. It is used when the focus of the study is on the entire phenomena.
- Single case, embedded: This considers a single case too, but with multiple units of analysis, because attention is paid to the units that form the case.
- Multiple cases, holistic: This uses multiple cases with the objective of generalizing the results, but it uses a holistic approach because of the impossibility of identifying many units of analysis.
- Multiple cases, embedded: for this type, multiple cases and units of analysis are used. Moreover, the results from this type of case are likely to be replicable and generalizable.

In this research, multiple cases will be used. On the other hand, the case chosen to be embedded because the unit of analysis is more than one.

- Design data collection protocol: The selected case studies will develop both qualitative and quantitative data as an outcomes. The focus will be on the literature review for the purpose of collecting data. This is to identify the building design components, which have impact on building energy performance.

#### 4.2.6.2. Preparing, collecting, and analyzing

- Conducting a case study: figure 4.8 presents the process of performance based design (case study) procedure.

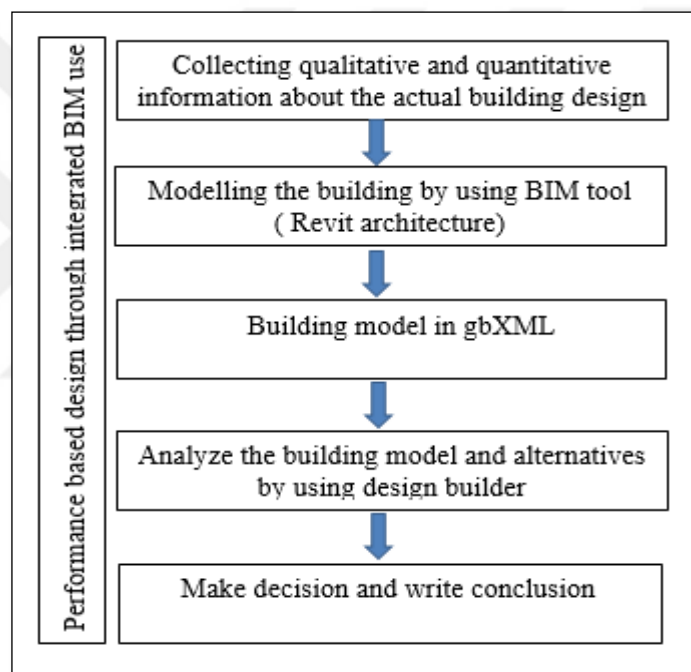

**Figure 4.8.** Performance-based design (case study) procedure through integrated BIM use

In this research both qualitative and quantitative information were gathered about the building case study for designing and preparing it for analysis. Then, the building is modeled by using BIM tool (Revit architecture. Then the created model is imported to design builder (one of the energy simulation tools for analysis). This is done through (gbXML), as a way of exchanging data between BIM and energy analysis tools.

#### **4.2.6.3. Analysis and conclusion**

-Writing a cross case conclusion: once each of the conducted cases studies are analyzed, the researcher will search for any pattern in order to write up conclusions.

-Writing a case study report: hence the researcher will try to present the conclusions of all case studies in a report.



## **CHAPTER 5**

### **PERFORMANCE BASED DESIGN THROUGH INTEGRATED BIM USE: A RESIDENTIAL BUILDING CASE STUDY**

As highlighted in chapter 3, the energy efficiency of buildings can be greatly enhanced through the combination of BIM "which helps to create the building models with attainable data" and energy simulation software (ESS), "which allows engineers and architects to solve and prove the energy data by conduction different simulation models". Thus, both can help in promoting building performance, and can assist designers to design building more consciously with effective design decisions.

Therefore, based on the case study procedure identified in chapter 4 (see figure 4.8) we will conduct a residential building case study to explore or exploit the role of BIM and ESS in achieving efficient energy building with less CO<sub>2</sub> emission. A case study methodology that helps to acquire qualitative and quantitative insights and understanding current practice and literature will be adopted. Experimental modelling, testing and simulation will be carried out in the research: Revit based BIM modelling is followed with gbXML (Green building XML) and Design Builder for energy performance simulation in relation to the building orientation and envelopes.

#### **5.1. Rationale of Using Revit Architecture and Design Builder Software for the Simulation Process**

The software used in this study was selected by considering four main criteria. Firstly, as stated by kurul et al. (2013), currently Revit architecture is considered as one of best BIM tools being used in construction sector. Secondly, as soon as the building is modelled, it is necessary to choose appropriate energy simulation software. Design builder was chosen to perform the simulation process. This was generally due to the ability of the software in experiencing too many orientations and building envelope in a very little time without the need to return back to the main geometric building model. Furthermore, as mentioned by Bahar et al. (2013), design builder can be used for



thermal analysis and design, calculating cooling and heating energy performance, artificial and natural lighting, and heat transmission and scheduling. To this end, design builder is chosen due to its ability to carry out the detailed energy simulation using energy plus. Thirdly, it is important to find a way that makes the communication easy between BIM software and energy simulation software. This kind of connectivity can be defined under the term of interoperability. The term interoperability is defined in many ways by many authors, commonly they all have the same meanings.

Rezaei et al. (2014) and Bahar et al. (2013) defined interoperability as a way of communication and exchanging data among two or more various software. Kensek (2014) refers to interoperability as a tool of transferring data in an effective way to different domains and platforms. Moreover, Eastman and Crosby (2011) said that interoperability makes it sure for data to be transferred without the need of replication and it let many applications to be used in the same time at various phases of a project.

Sokolov et al. (2011) reported that the development of XML (extensible mark-up language) marks a significant success in transferring building data between BIM application and building energy analysis tool, confirming that gbXML (Green building XML) format is considered as the best format for exchanging data and interoperability. This was also agreed by Lagueta et al. (2014), who enforced the use of gbXML for writing BIM model due to its features of making it able to include data such as thermal descriptive information. They also stated that the gbXML is considered as a database, where data such as descriptive information are connected with the building geometry. Another advantage of using gbXML was mentioned by Ham and Golparvar-Fard (2015), who said that by using gbXML in the importing process from the BIM software to energy simulation tool, it is not necessary to redesign the building model within the simulation tool, considerable time would be saved too. Finally, the last reason for using Revit and design builder was due to their ability to easily connect through gbXML through which a building model is seamlessly transferred from Revit to design builder for the purpose of analysing building energy performance.

## **5.2. Case Study Description**

The building is a small domestic construction which is now being inhabited by a family. It is a 2 story house building (see figure 5.1).



**Figure 5.1.** 1st Floor and 2nd Floor of the house building

The first floor comprises of two bedrooms, a kitchen, a dining room, a living room, a bathroom and two WC. The second floor consists of three bedrooms, two bathrooms, a WC and a roof.

### 5.2.1. Model development

To show how the building model would look like, Revit architecture 2016 was used or the development of a 3D house plan, building materials like walls, brick, and wood were edited to the building, also topography such as trees and plants. Figure 5.2 shows the building geometry with completed rendered image.



**Figure 5.2.** Building 3D geometry

Then, to run energy simulation, the building model was transferred from Revit by using gbXML scheme (see figure 5.3).

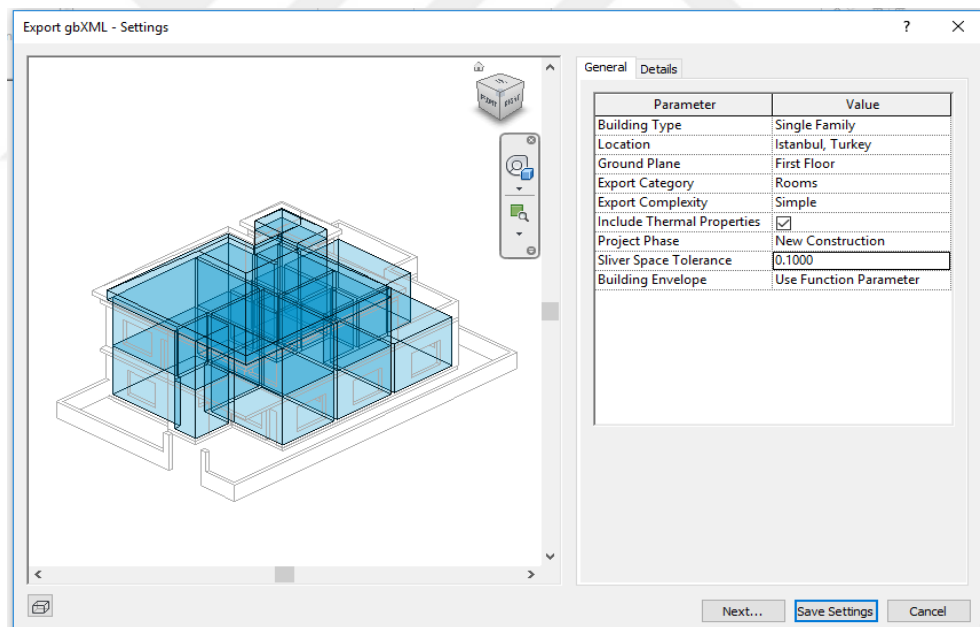

**Figure 5.3.** The exporting process from Revit to gbXML

Once the building model is totally transformed, it will be saved as a gbXML file. Then it is imported into design builder. The final results of the importing process into Design Builder are presented in figure 5.4.

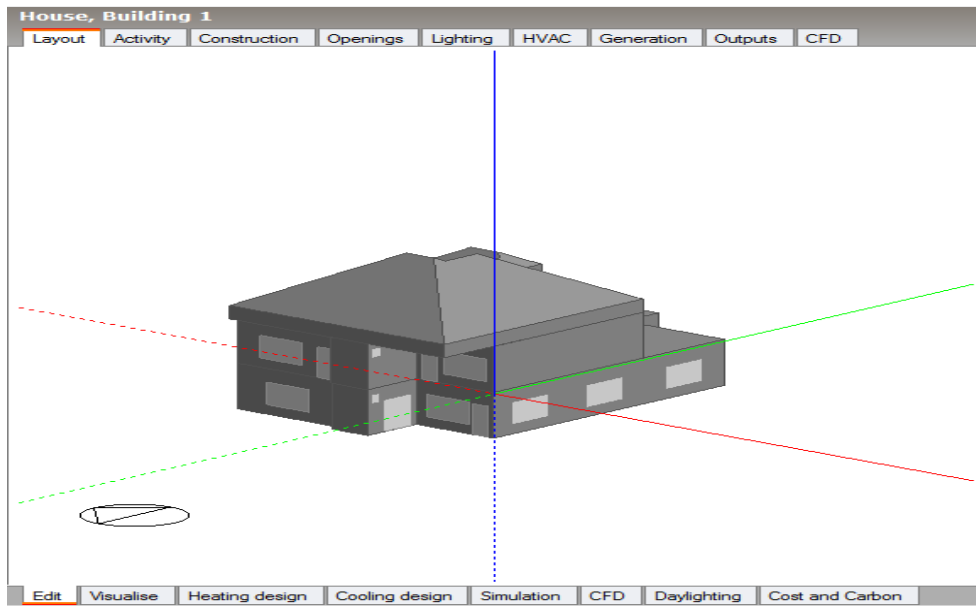

**Figure 5.4.** House building model in design builder

As shown in figure 5.4, all the building data seems to be correct. Design Builder provides templates that can be used to quickly load data into the model. These templates are: location, activity, construction, glazing, HVAC system and lighting templates.

### **5.2.2. Preparation of energy model**

After importing the building geometry model into Design Builder, the parameters of model analysis can be defined and the baseline energy model can be developed.

#### **5.2.2.1. Assigning location and weather data**

The location assigned to the model are shown in figure 5.5.

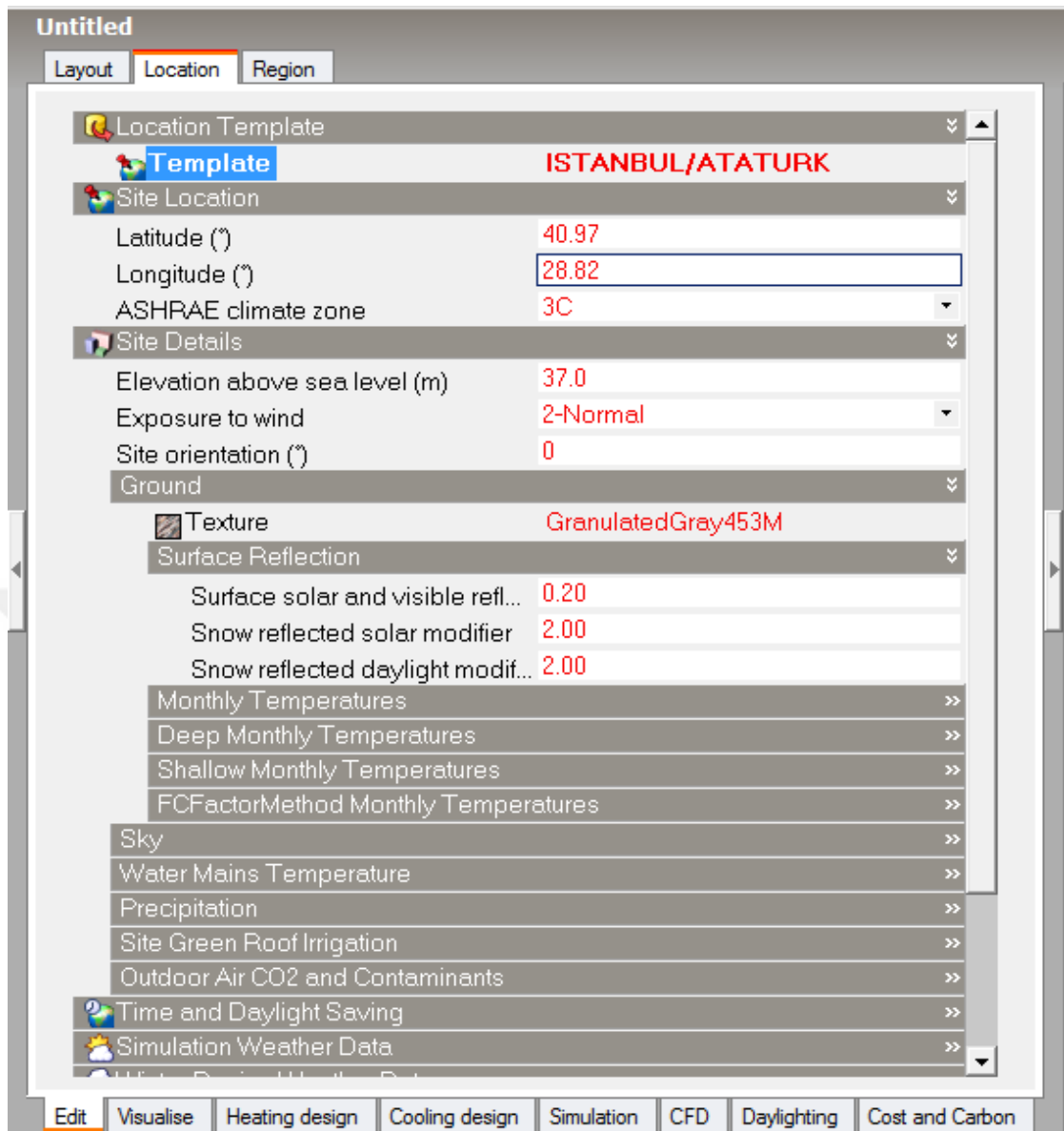

**Figure 5.5.** Location template of the actual building model

As shown in figure 5.5, in Design Builder, the weather data can be obtained from ASHRAE weather data base. For this study, the weather file of Turkey-Istanbul is chosen. The longitude and latitude of the chosen location are  $40.97^{\circ}$  E and  $28.82^{\circ}$  N respectively, and the altitude is 37 meters above sea level, the site orientation is (0) direction, and finally the climate zone is 3C.

### **5.2.2.2. Construction materials used in the actual building design**

The physical characteristic of the opaque envelope materials used for the actual design model including external walls, internal walls, floors and slab are illustrated in table 5.1.

**Table 5.1.** The physical characteristic of building envelope materials

Elements	Material	Thickness (m)	R-value (M <sup>2</sup> -k/W)	U- value (W/m <sup>2</sup> . k)
External wall	Cement plastering	0.015	0.486	2.493
	Block hollow wall	0.2		
	Gypsum plastering	0.015		
Internal wall	gypsum plastering	0.015	0.621	1.610
	Block hollow wall	0.2		
	Gypsum plastering	0.015		
Ground floor	Concrete medium density	0.1	0.366	2.732
	Concrete medium density	0.05		
	Ceramic clay tile	0.1		
Flat roof	Ceramic tile	0.01	0.334	2.994
	Cement mortar	0.025		
	R.C.C concrete slab	0.15		
	Gypsum plastering	0.015		
Pitched roof	Clay tile roofing	0.025	0.341	2.930
	Air gap	0.02		
	Roofing felt	0.05		

Regarding the properties of the window system used for the building (see table 5.2).

**Table 5.2.** The physical properties of glazing

Material type	Thickness (mm)	Frame type	Total solar transmission (SHGC)	U- value (W/m <sup>2</sup> . k)
Single glazing	3	Painted wooden window	0.858	6.257

As shown in table 5.2, a single glazed façade with no shade is used and consists of one layer of transparent glass. The frame type of the window is wooden.

### 5.2.2.3. Lighting system used in the actual building design

The type of lighting and the values related to energy consumption are illustrated in Table 5.3.

**Table 5.3.** Building lighting type and illuminance values

<b>Zone</b>	<b>Lighting type</b>	<b>Normalized power density (W/m<sup>2</sup>-100 lux)</b>	<b>Target illuminance (lux)</b>	<b>Energy consumed by lighting (W/m<sup>2</sup>)</b>
Bedroom	Fluorescent	5	100	5
Hall	Fluorescent	5	150	7.5
Reception	Fluorescent	5	150	7.5
kitchen	Fluorescent	5	300	15
Corridor	Fluorescent	5	100	5
Bathroom	Fluorescent	5	150	7.5
Toilet	Fluorescent	5	100	5

As shown in table 5.3, the type of lighting used for the buildings design model is fluorescent. The data and values related lighting template are as follows: a normalized power density of 5 (W/m<sup>2</sup>-100 lux), which is multiplied by the target illuminance of each zone to determine the lighting energy consumption for each zone. Moreover, the type of illuminance used for the actual building is suspended.

#### **5.2.2.4. HVAC system used for the actual building design**

As HVAC equipment's consume the biggest portion of energy supplied for building spaces, defining the systems used in the spaces modeled and manipulating their operational profiles is a critical step. Luckily, design builder software enables its users to easily create, design, and control the HVAC system.

Firstly, to create the HVAC system, it's first necessary to define the time operation of the system as well as the cooling and heating set points. A residential schedule was chosen for all the spaces of the building. Regarding the cooling and heating profiles a constant heating set point of 18.0°C and a constant simulation cooling point of 25°C were selected for the model simulation. Secondly, the HVAC system was sat up, split and separate ventilation machine were chosen for both cooling and heating, and electricity type was chosen to be fuel.

#### **5.2.3. Parameters Studied**

To save energy cost, a precise energy design is the most effective technique (Mirnoori, 2013). Firstly, a passive design strategy was applied by manipulating the building orientation until the most appropriate direction of the building is identified for the minimum use of energy. Secondly, different envelope materials including walls,

insulation and glazing were simulated and compared to the actual materials used to achieve maximum energy saving in regard of heating and cooling loads.

### 5.2.3.1. Building orientation

Building orientation has an impact on buildings to naturally heat and cool internal spaces. Therefore, using BIM will help in understanding the effect of orientation on building energy use during the design stage (Abanda and Byers, 2016). For this reason, a couple of tests were carried out to study the impact of orientation on the total energy consumption. In this case, the word test mean using design builder software to manipulate the building model and collect information about the energy performance in each test. The orientation of virtual building was at (0) direction, this means that the front side of the building is at south direction. Then the direction was rotated 45 degrees counter clock wise from 0 to 360 at each test (figure 5.6).

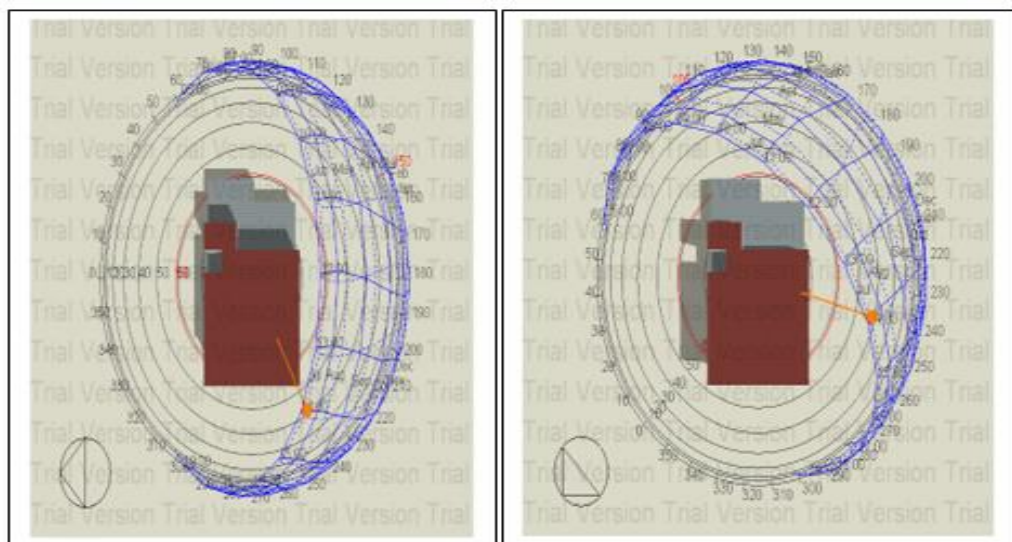

**Figure 5.6.** Building solar radiation rotated every 45 degrees

As shown in figure 5.6, the building orientation toward the sun was changed every 45 degrees. This is to simulate and study the effect of orientation at all direction to achieve the best one.

### 5.2.3.2. External walls

Table 5.4 illustrates the physical properties of different wall materials.



**Table 5.4.** The properties of building wall materials

Wall material	Thickness (m)	Density (kg/m <sup>3</sup> )	Thermal conductivity (w/m k)	U- value (w/m <sup>2</sup> . k)
Hollow block (heavy weight)	0.2	1220	1.35	2.493
hollow block (light weight)	0.2	1400	0.51	1.934
Burned brick	0.2	1920	0.72	2.048
Aerated brick	0.2	1000	0.3	1.087

As shown in table 5.4, for the actual design model, concrete block-hollow (heavy weight) with U-value of 2.493 is used. Three other materials are used, simulated and compared to each other, those materials are: concrete block-hollow (light weight), burned brick, and aerated brick.

### 5.2.3.3. Wall insulation

The properties of the insulation materials considered in this study are illustrated in table 5.5.

**Table 5.5.** The properties of different insulation materials

Properties	Expanded polystyrene (EPS)	Extruded polystyrene (XPS)	Rock-wool (RW)
Thermal conductivity, W/m K	0.04	0.034	0.47
Density, kg/m <sup>3</sup>	15	35	92

Insulation materials were added to the wall construction and simulated. As mentioned by Uygunoğlu et al. (2016), the most insulation materials used in Turkey are as follows: Expanded Polystyrene foam (EPS), Extruded Polystyrene (XPS) and Rock-Wool (RW). These materials were tested simulated and the best one was chosen for the optimized building design in term of heating and cooling energy consumption.

### 5.2.3.4. Glazing

The physical properties of both single and double-glazing windows are illustrated in table 5.6.

**Table 5.6.** The physical properties of different glazing types

Window type	Thickness (mm)	Frame type	Total solar transmission (SHGC)	U- value (w/m <sup>2</sup> . k)
Single glazing	3	wooden window	0.858	6.257
Double glazing	6	wooden window	0.468	3.157

As shown in table 5.6, for the actual building model, a single glazing-clear 3mm was used. Double glazing- grey 6 mm was also tested and compared to the actual one.

### 5.3. Analysis and Results

The results of the case study can now be analyzed and discussed.

#### 5.3.1. The impact of orientation on building energy consumption

To study the impact of building orientation, the building has been rotated counter clock wise each at 45 degrees and the results are illustrated in table 5.7.

**Table 5.7.** The impact of building orientation on building energy consumption

Test	Building orientation	Heating energy consumption (KWh)	Cooling energy consumption (KWh)	Annual energy consumption (KWh)
1	(0°)	16985.08	4077.94	21063.02
2	(45°)	16892.65	4037.87	20930.52
3	(90°)	16676.59	4162.64	20839.23
4	(135°)	16682.38	4459.20	21141.58
5	(180°)	16673.74	4445.71	21118.71
6	(225°)	16716.44	4403.59	21120.03
7	(270°)	16726.16	4248.61	20974.77
8	(315°)	16929.63	4282.64	21212.27
9	(360°)	16985.08	4077.94	21063.02

**Test 1: 0-degree:** This represents the actual building direction. The front side of the building is facing south direction. The rooms located at the front side are the kitchen and reception rooms. In this case, the total cooling and heating load are 4077.94 KWh, 16985.08 KWh respectively and the total annual energy consumption is 21063.02 KWh.

**Test 2: 45-degree:** the building is rotated 45-degree counter clock wise from the base run. This rotation will change the percentage of windows area that will be open to sun

radiation. In this case, the total cooling and heating load are 4037.87 KWh, 16892.65 KWh respectively and the total annual energy consumption is 20930.52 KWh.

**Test 3: 90-degree:** the building is rotated 90-degree counter clock wise from the base building direction. In this instance, the right side of the building is facing the south direction, where considerable number of windows will be open to the sun radiation. The total cooling and heating load are 4162.64 KWh, 16676.59 KWh and the total annual energy consumption is 20839.23 KWh.

**Test 4: 135-degree:** The building is rotated 135-degree counter clock wise from the initial case and both the right and back side of the building is facing the south direction. In this case, the cooling and heating load are 4459.20 KWh, 16682.38 KWh respectively and the total annual energy consumption is 21141.58 KWh.

**Test 5: 180-degree:** The building is rotated by 180-degree counter clock wise. In this case, the front of the building is facing the north direction. The cooling and heating load are 4445.71 KWh, 16673.74 KWh respectively and the total annual energy consumption is 21118.71 KWh.

**Test 6: 225-degree:** The building is rotated by 225-degree counter clock wise. The cooling and heating load are 4403.59 KWh, 16716.44 KWh and the annual energy consumption is 21120.03 KWh.

**Test 7: 270-degree:** The building is rotated by 270-degree counter clock wise. In this case, the west side of the building is facing the south direction where a small number of windows will be opened to the sun direction. In this case the cooling and heating load are 4248.61 KWh, 16726.16 KWh respectively and the annual energy consumption is equal to 20974.77.

**Test 8: 315-degree:** The building is rotated by 315-degree from the base case, the cooling and heating load are 4282.64 KWh, 16929.63 KWh respectively and the annual energy consumption is 21212.27 KWh.

It is obvious that the less energy consumption is achieved when the building is at (90°) making an annual energy consumption equal to 20839.23 KWh, while the maximum energy consumption is achieved when the building is at (315°) making an annual energy consumption equal to 21212.27 KWh. Moreover, when comparing the best

direction ( $90^\circ$ ) to the actual building orientation ( $0^\circ$ ), an energy saving equal 223.79 KWh can be achieved.

### 5.3.2. The Impact of wall materials on building energy consumption

Once the optimum building orientation is achieved, three types of wall materials were tested and simulated. This is to calculate the impact of wall materials on heating, cooling and annual energy consumption. As mentioned previously, heavy weight hollow block is used for the actual building. The other three types of wall material are: hollow block light weight, aerated brick and burned brick respectively (see table 5.8).

**Table 5.8.** The impact of wall material type on building energy consumption

Wall type	U- value (W/m <sup>2</sup> -k)	Heating energy consumption (KWh)	Cooling energy consumption (KWh)	Annual energy consumption (KWh)
Hollow block (Heavy)	2.493	16676.59	4162.64	20839.23
Hollow block (light)	1.938	16621.90	4159.53	20727.12
Aerated brick	1.087	16542.57	4137.82	20680.39
Burned brick	2.048	16636.19	4149.35	20785.54

As shown in Table 5.8, the lowest energy consumption is recorded when aerated brick is used, making an annual energy consumption equal to 20680.39 KWh. This is because aerated brick has the lowest U-value 1.087 (w/m<sup>2</sup>-k). Therefore, using aerated brick which has the best energy performance instead of hollow block which is used for the actual building wall will lead to energy saving equal to 158.84 KWh.

### 5.3.3. The impact of insulation on building energy consumption

The effect of insulation materials on the heating and cooling energy performance for are illustrated in Table 5.9.

**Table 5.9.** The impact of insulation materials on building energy consumption

<b>Insulation materials</b>	<b>Thickness (m)</b>	<b>Heating energy consumption (KWh)</b>	<b>Cooling energy consumption (KWh)</b>	<b>Annual energy consumption (KWh)</b>
Expanded polystyrene (EPS)	0.020	16500.78	4129.90	20630.68
Extruded polystyrene (XPS)	0.020	16496.49	4129.44	20625.93
Rock-wool (RW)	0.020	16504.85	4130.3	20635.15

As shown in table 5.9, When using extruded polystyrene (XPS), the total energy consumption is reduced to 20625.93 KWh, while the energy consumption of expanded polystyrene (EPS) and rock-wool is equal to 20630.68 KWh, 20635.15 KWh respectively.

Therefore, based on the result, it is obvious that the extruded polystyrene is the best material to be used for wall insulation.

#### **5.3.4. The impact of glazing type on building energy consumption**

The effect of glazing type on the heating and cooling energy consumption is shown in Table 5.10.

**Table 5.10.** The impact of glazing type on building energy consumption

<b>Window type</b>	<b>U- value (W/m<sup>2</sup>-k)</b>	<b>Cooling energy consumption (KWh)</b>	<b>Heating energy consumption (KWh)</b>	<b>Annual energy consumption (KWh)</b>
Single glazing-clear-3mm	6.257	4129.44	16496.49	20625.93
Double glazing-clear-6mm	3.157	4099.27	16495.45	20594.72

As shown in table 5.10, single glazing-clear 3mm which is used for the actual building, will lead to total energy consumption equal to 20625.93 KWh. While the use of double glazing- clear 6mm will lead to total energy consumption equal to 20594.72 KWh. As a result, an energy saving equal to 31.21 KWh can be achieved with the use of double-6mm glazing.

#### 5.4. Case Study Findings

The emerging BIM have rarely been implemented in energy simulation studies. Consequently, the advantages of evaluating the energy need of buildings before being constructed is not earned. In this study, Revit architecture and Design Builder were both employed to carry out the energy analysis in term of building orientation and envelope materials. Moreover, this study was successful in showing that building design parameters such as building orientation and envelopes have impacts on energy consumption. It has also showed how Revit architecture and Design Builder can work through gbXML to carry out building energy analysis. The main findings are presented as follows:

- The orientation of building should be chosen carefully before deciding its orientation. It must be selected based on the weather characteristics and climatic implications of the area because it may impact the building energy performance badly. According to the achieved results, building orientation can impact the energy load making (223.79 KWh) energy saving.
- According to the study on wall materials, it was concluded that aerated brick has the maximum impact on energy consumption, which makes (158.84 KWh) energy saving for one year.
- In regard to the insulation materials, it was proved that insulation material influences energy consumption. Among the three materials identified previously, extruded polystyrene with (0.02m) thickness was the most appropriate and efficient material to be used.
- In term of window types, it was concluded when using double glazing 6mm 31.21 KWh energy saving will be achieved when compared to single glazing 3mm.

Consequently, a concurrent procedure is highly needed to make active decisions during the design stage especially, when there are many alternatives in place. Based on the results, integrating BIM with energy software analysis can greatly help to solve this issue, that's why a strategic BIM use is needed in the concept design. Thus, in the next section, we will define an initial BIM design and optimization framework considering the local values and factors influencing the concept design for energy efficient buildings in Turkey.

## **5.5. The Initial BIM Based Design and Optimization Framework**

As highlighted in chapter 2, there are numerous studies proved that selecting materials by taking account of climatic conditions results in less energy use and comfortable indoor environment. But, nowadays buildings are designed without taking account of environment situation. For example, new buildings in Turkey consume a great amount of energy to supply comfort conditions. This is due to inefficient building design (Kocagil and Oral, 2015). This is also supported by (Mangan and Oral 2016), who mentioned that the new building design in Turkey does not take into consideration the environmental impact and energy assessment. Moreover, they also declared that buildings in Turkey just like all over the world are highly responsible for CO<sub>2</sub> emission, which is mainly caused by the high energy use. Therefore, improving the building energy performance is needed, which in turn will result in a fewer CO<sub>2</sub> emission. That is why, it's necessary for designers to put more attentions and considerations on building energy performance and sustainability. To make sure that these considerations are being reflected in building performance, effective design decisions should be made by the stakeholders earlier in the early design stage. Using BIM simulating the building energy performance has greatly enhanced the energy analysis process, so this method gained momentum (Cho and Woo, 2012).

In this regard, the core benefit of BIM is already being defined in chapter 3, the importance of BIM in providing sustainable buildings with efficient energy performance for their operations, less CO<sub>2</sub> emission and in the same time deliver comfortable environment for their occupant are also covered. Moreover, the literature, showed that integrating BIM model with energy analysis software will help the designers in predicting and creating an efficient and optimized building performance.

To validate these findings, Revit based BIM modelling followed with gbXML (Green building XML) and Design Builder for energy performance simulation were carried out for a case study building in this chapter, and the results showed that, there is a need of a concurrent procedure for making active decisions in the early design stage by using BIM especially when there are many alternatives to choose. Consequently, a strategic BIM guide will be defined considering the local values and factors influencing the concept design for energy efficient buildings in Turkey

### 5.5.1. Hypothetical BIM based design optimization framework to be implemented

Generally, a framework can be defined as a systematic set of relationship or a conceptual scheme, structure, or system. A good framework should be easily to understand, clear, have boundaries and be expandable where necessary (Booth, 2013).

When the decision is made to adopt BIM in a practice, the question then becomes what the best way is to implement BIM. Therefore, in this section, an initial hypothetical BIM based design framework will be defined. This is to develop a guide or approach for how BIM can be adopted successfully for design optimization and energy efficient building at the design stage.

Based on the main findings achieved in section 5.4, which was the need of an effective procedure to make active decisions in the early design stages by using BIM, together with the problems highlighted in chapter 1 and the literature covered in chapter 2 and 3, an initial hypothetical framework is developed (see figure 5.7).

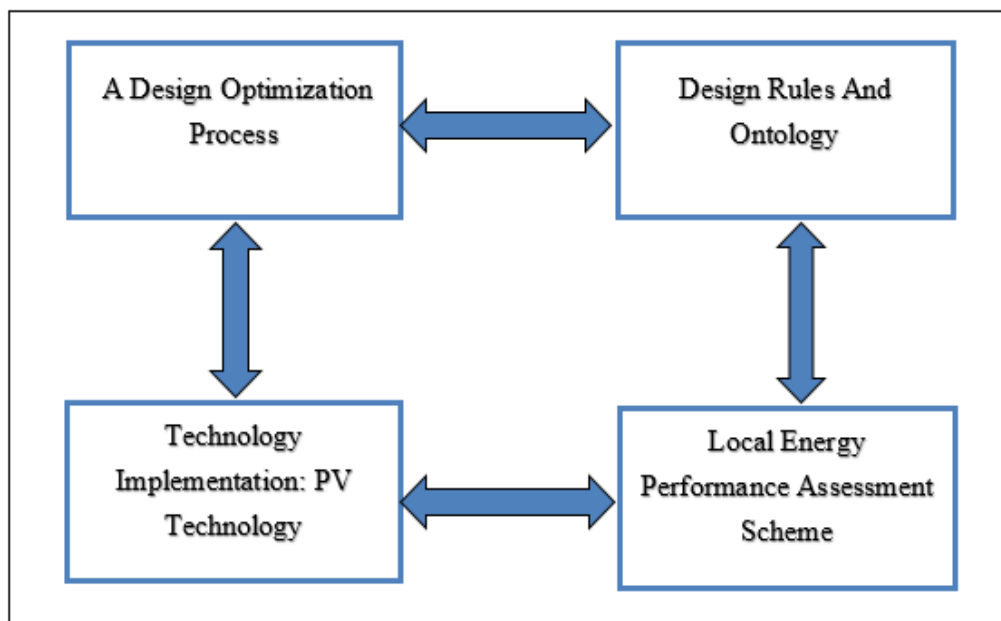

**Figure 5.7.** The initial BIM based Design Optimization Framework

As shown in the figure 5.7, the framework is consisting of four components which are a design optimization process, design rules and ontology, technology implementation (PV technology), and a local energy performance assessment scheme. These components are formulated into a framework and will briefly be explained in the



following sections for a coherent representation of the thought process for the hypothetical definition of the BIM implementation framework.

#### **5.5.1.1. A design optimization process**

As people's awareness of building energy consumption and environmental impact continues to increase, designers, architects and planners are requested to provide more consideration on building energy performance and sustainability. In order to check whether these considerations are implanted in the building design and performance, an effective design decisions should be made by the stakeholders during the early design stage of the building (Cho et al., 2012).

To assess and improve the building design and performance, various analysis reinforced by simulation should be part of an integrated design process. So, the question is why it is necessary to perform simulation and analysis to design and efficient building performance? According to Cho et al. (2012), Building performance simulation allows the engineers and architects to investigate various design alternatives and choose the most energy efficient alternatives. Moreover, as mentioned by Aksamija (2013), it should be considered as an essential part of the design process, this is due to the opportunity of investigating more than one design option and selecting the most appropriate one.

As mentioned before, BIM can greatly be used for performance and energy simulation, where the energy analysis can also be combined with the design process. However, the main issue in implementing performance-based design is how to effectively combine various technologies that exist in multiple domains and provide comprehensive building performance analysis in a collaborative manner in the design process.

Unfortunately, the full potential of BPS (building performance simulation) has not been realized because the lack of integration prevents team members to work collaboratively throughout the project lifecycle (Jeong and Kim, 2016). This is mainly due to the fact that some architects and designers find it hard to use these tools because they are incompatible with their work methods or requirements, or the tools are complex (Aksamija 2013).

Energy performance analysis is usually done after the architectural design and construction documentation is completed. The absence integration into the design

process will lead to an inefficient design process (Cho, C. S et al., 2012). Therefore the use of BIM during building energy simulation will greatly improve the energy analysis process, this is due to fact that the uptake of the BIM model have increased the need for collaboration among different stakeholders (Jeong and Kim, 2016). Moreover, to design energy efficient buildings, a distinctive design method is highly required rather than the conventional building design. Using building modelling and simulations, and data driven design approach are considered to be the basic requirements in designing efficient building performance.

During the design stage, different design strategies regarding energy performance could take place including active and passive strategies. However, BIM design and energy analysis software are currently different and necessitate exchanging of data and information related to the building (Aksamija, 2013).

The method or approach for data and information exchange between BIM and energy software are mainly depends on the purpose of the analysis and the type of information required. For instance, design builder software can be used during the early design stages and can be significantly be used for various types of analysis such as building orientations and shadings. Exchanging data between Revit and design builder can be done through gbXML file, which is created to transfer the properties of building easily for BIM to energy analysis software. However, importing the analysis results back into BIM model is challenging, therefore there is also a need to develop an approach which ensure transferring data and information properly and correctly between BIM model and energy software analysis.

Therefore, based on the fact mentioned above, a design process modelling which sets a flow of activity and roles played by each actor involved, together with the information required in the process, will be developed, this is to give a clear understanding of how the design optimization process can be done by the adopting of BIM in the early design stages. This will be fully covered and detailed in chapter 6 by conducting a real building case study.

#### **5.5.1.2. Technology implementation (PV technology)**

One of the best and appropriate strategies for designing building with low energy is the use of advanced building technology and renewable energy system. Turkey's

energy and environmental problems caused by the increase in building energy use, necessitate the application of active and energy efficient strategies and renewable energy system in buildings sector which are the major source of energy consumption.

As Turkey is greatly rely on the exported energy, therefore, encouraging the use of renewable energy such as photovoltaic system, supporting for in site energy generation to supply the building energy needs will be a key measure to address Turkey's energy-related challenges and address sustainability issues (Mangan and Oral, 2016).

As explained in chapter 2, Turkey has the third greatest amount of solar in the world. However, in terms of solar potential, the building integration of renewable energy such as solar panels is not successful enough. Therefore, it's necessary to include such technologies in the building design. Thus, as a first step, there will be a comprehensive exploration of how PV panels can successfully be designed for building in Turkey. This will be done by giving a clear understanding of how PV can be designed by using design builder software.

For the purpose of optimizing PV performance or annual output, Dos Santo Sand R ther (2012) mentioned that, to optimize the annual PV generation, performance parameters such as the orientation of PV, tilt angle and row spacing between the modules are a main concern, as the design of the system and electrical formation must maximize the sunlight exposure.

Therefore, based on the facts mentioned above, the major parameters which are related to the orientation of PV system, tilt angle as well as the space between PV arrays, will be taken in the design and optimization process. The effects of these parameters on PV systems generation and performance will be analyzed and deeply explained in chapter 6, by conducting a real case study considering local climate zone of Gaziantep-Turkey.

### **5.5.1.3. Design ontology and rules reflecting local values**

Buildings are one of the largest users of energy, material resources and water resources, and are heavily polluted. In response to these impacts, there is a growing awareness of the need to adopt appropriate strategies and actions to make construction activities more sustainable (Akadiri et al., 2012).

Sustainable building design looks for lowering the energy consumption, gives priorities to non-toxic materials, reduce impacts on environment by decreasing gas emissions, and ensure quality and durability over price. It generally leads to eliminate the negative impacts on environment as well as ensures comfort of building occupants (Abdelhameed, 2017). In this context, sustainable design can be adopted to design the building and environment in response to the values of economic, social, and ecological sustainability.

Since the building sector comprises around 40% of the world's total energy use and around 44% of total materials use (Li, Z, 2006). Similarly, greenhouse gases causing global warming result mostly from the building sector (Sayın, 2006). Therefore, ecological and passive building design has gain importance recently. Moreover, to reduce these effects, ecological building design criteria should be adopted in designing the buildings.

Ecological building design includes building designs containing building materials which reflect local environment, reduce energy consumption to minimum, use local and renewable resources instead of natural sources, create healthy indoors, use solar energy, and natural lighting (Gultekin and Alparslan, 2011). Furthermore, the goal of ecological building design is to reduce the use of natural resources without disrupting the ecological balance, to use local resources economically, to minimize harmful effects of buildings on the environment, and to provide appropriate conditions for human comfort and health (Gültekin and Yavaşbatmaz, 2013).

As mentioned by Omrany and Marsono (2016), Passive buildings can achieve the minimum energy needs by enhancing the heat gains and losses of its envelopes. In this case, building thermal comfort can be achieved without using energy appliances and only little amount of energy will be needed during the peak hour temperatures

Based on the facts mentioned above, the use of passive strategies and methods for building design can be a promising way to ensure efficient building in term of energy performance. Therefore, there will be a comprehensive review of passive design strategies, meanwhile a real passive building will be analyzed, different design parameters will be studied and simulated for developing rules and guidelines to be implemented in building design and how developments should be planned to decrease

building energy consumption and carbon emissions in order to protect the environment in Turkey.

Within this concept, designers and engineers can adopt principles related to passive designs to create efficient designs considering the local environment conditions for the purpose of efficient energy building. This will be explained in chapter 7, by conducting a real passive house case study which is constructed in Gaziantep-turkey.

#### **5.5.1.4. Local energy performance assessment scheme**

As the building industry's awareness of sustainable development continues to increase, the implementation of energy rating procedures for assessing buildings is becoming increasingly important. Generally, there are different building assessment certificates, the most applicable assessment schemes today are Leadership in Energy and Environmental Design (LEED), Building Research Establishment Environmental Assessment Method (BREEAM) and Green Star (Roderick et al, 2008). All of these schemes are based on rating systems that are applied to many of building types, including new and existing buildings. Mainly, these rating schemes cover a range of environmental issues such as materials, energy, water, pollution, indoor environmental quality and construction sites. The most important credit for all schemes which is also an important element in achieving sustainable building, is the energy consumption or carbon emission in building.

To develop an energy assessment scheme, firstly, it is necessary to take on an assessment for the energy performance of the building's characteristics and system. Energy scheme and certificate can provide a wide range of information about the building performance with rating itself, this may include recommendation to enhance the building energy performance. It is also considered to be as an important source for recommending and advising the building's owners about the profits of improving the building for better rating as it involve recommendations to enhance the buildings envelope materials as well as improving the space heating and cooling system (Arkesteijn and van Dijk 2010). However, in Turkey, a few large-size ecological buildings which have been constructed by private organization recently, were certificated with international green rating systems. Nevertheless, severe problems have been encountered while adapting these international systems to local conditions, which is why they are not currently widely used in Turkey (Gültekin and Ersöz, 2013).

Moreover, there is an agreement that global certifications of green buildings is not applicable because of regional differences in environment conditions, amount of energy, raw material, water, green materials availability, and economic conditions (Ilter and Ilter, 2011).

Therefore, as a solution to this problem, there is a need to develop an energy assessment scheme for buildings considering the local design criteria and conditions for Turkey. Accordingly, an evaluation method will be developed in this section in order to determine the ecological success level of the passive building design case study. This evaluation is based on an objective scoring by determining the evaluation measures, the implementation status of these measures in the design, and the implementation success. This will be deeply detailed and covered in chapter 7 after identifying the building design rules.

## **5.6. Conclusion**

In this chapter, a residential building case study was conducted by using BIM and energy simulation tool (Design Builder). Different design parameters were studied, and their impacts on building energy performance were also calculated. The results indicated that, using BIM during the early design stages can help in making active design decision and thus optimizing building design. Accordingly, an initial BIM framework was developed. This framework consists of four components, each one of them will be considered and identified through the application of multi case studies in the next following chapters.

## CHAPTER 6

### **BUILDING DESIGN OPTIMIZATION PROCESS AND TECHNOLOGY IMPLEMENTATION**

In this chapter, the first two components of the hypothetical framework, which is proposed in chapter 5 will be undertaken and identified. These components are, a design optimization process, and technology implementation. This will be done through conducting a real building (ARBIM building) case study in Gaziantep-Turkey.

Firstly, the design and optimization process in term of building energy performance will be explored. By integrating BIM tool (Revit architecture) with energy simulation software (design builder), the researcher will explain how to effectivity use Revit architecture to create an analytical building spaces when preparing BIM model for conversion to BPS (building performance simulation). This will be followed by describing the roles and responsibilities of stakeholders (clients, architectures engineers and energy expert) who are included in the process as well the information required to be used or created by one each of them. Moreover, how this information should be exchanged and transferred among the stakeholders involved in the design and optimization process to achieve a better decision during the early design stage will also be identified.

Secondly, the use of photovoltaic (PV) technology in the building design will be explored. This will be done by explaining the process steps needed to design PV models for building by using design builder software. Then, the main parameters and their impacts on PV performance, will be identified and studied.

#### **6.1. ARBIM Building Case Study**

The building is constructed in Hasan Kalyoncu University, Gaziantep, Turkey. The building is a university construction; it is a two-story building. The first floor consists of software presentation room, exhibition room, smart class room, office room, kitchen

and two WC. The second floor consist of energy laboratory room, control room, open office room, meeting room, archive room, two personal room, innovation laboratory room and whole room. Figure 6.1 shows both 2D plans of first and second floor of ARBIM building are shown in.

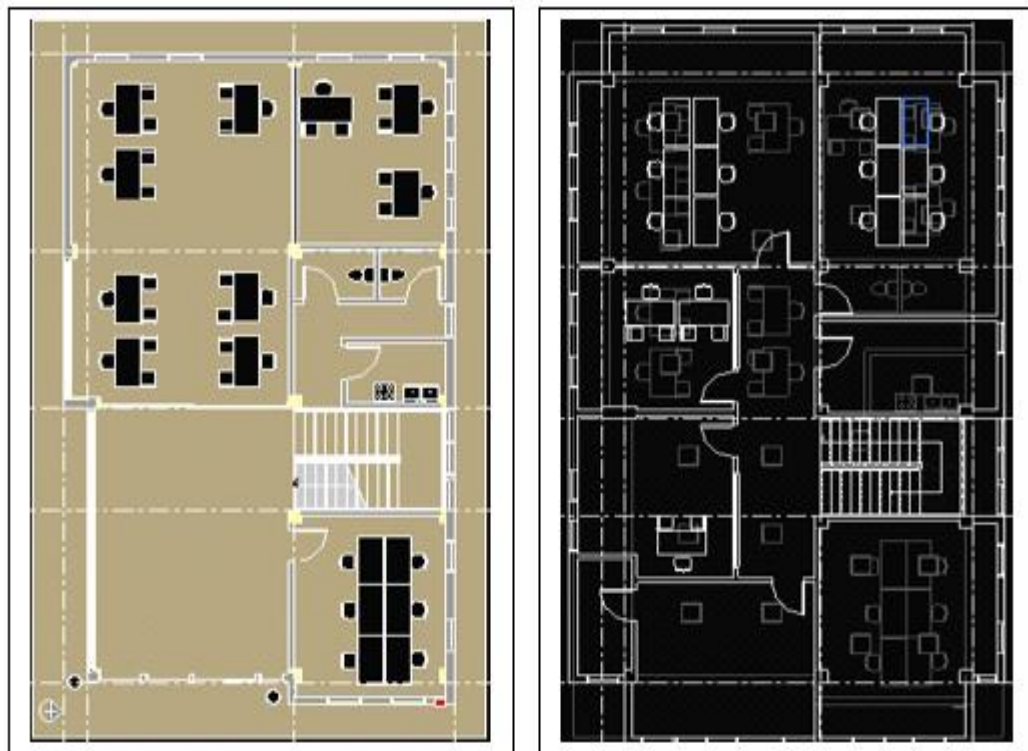

**Figure 6.1.** 1<sup>st</sup> and 2<sup>nd</sup> floor of ARBIM building

BIM software encompasses not only architectural geometry and spatial relationships of 3D architectural elements, it has also the feature of holding geographic information, quantities, and the characteristic of building components. It enables the stakeholders to be working as a team, managing data of the building during its life cycle. Working in 3D eliminates the errors to arise in buildings by decreasing the clashes in the building structure and components, which in turn will lead to less effort wasting and material on site (Hetherington et al, 2010).

However, there are too many designers who still work in 2D and using BIM is still not high (Hetherington et al, 2010). That's why, they found difficulties in using BPS. This is because the integrations among design models and energy models are still low (Jeong and Kim 2016). Due to facts mentioned above, it's necessary for designers and architects to learn and use 3D modelling as a part of building design process.



### 6.1.1. Model development and building description

Figure 6.2 shows the 3D geometry of ARBIM building and its topography by using Revit 2016.

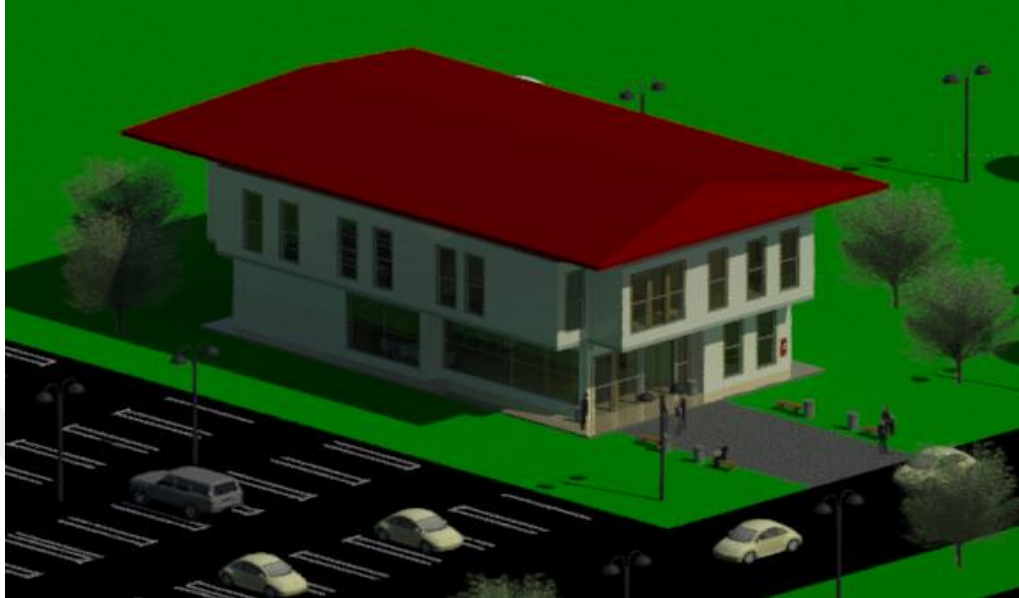

**Figure 6.2.** 3D of ARBIM building

As shown in figure 6.2, a 3D building geometry is created by using Revit architecture. This is to visualize the building and see how building looks in reality. Topography and site elements such as car parking, street, trees and shrubs were also added to the building model.

### 6.1.2. Energy model preparation

To prepare the 3D building for conversion to BEPM (building energy performance modelling), there are a number of steps architectures and designer should follow, this is to correctly define the analytical building spaces and prepare it for energy expert to conduct building energy analysis.

As a first step the building model should be separated in to thermal zones. The word thermal zones refers to a three dimension space in the building, also it refers to a space which is cooled and heated by using HVAC appliances (Douglass, 2011).

In Revit architecture thermal zone are identified by using room object. As the building zones are a three dimension spaces, it's necessary to make sure that both the area and volumes of thermal zones are saved in the building information models. This will

define the Rooms as 3D elements within the model. It can be done by ensuring that Area and Volumes are chosen for the room's calculation method in the Room and Area's tab on the home menu.

After selecting Area and volume for room computation, the thermal space can now be calculated at the wall-finish or wall-center. To be sure that there is no gaps between the zones during the conversion process, it's recommended to adjust the area and volume calculation at wall- center (Douglass, 2011). Figure 6.3 shows how to add volume data to the building model and how to adjust the area and volume calculation at wall- center.

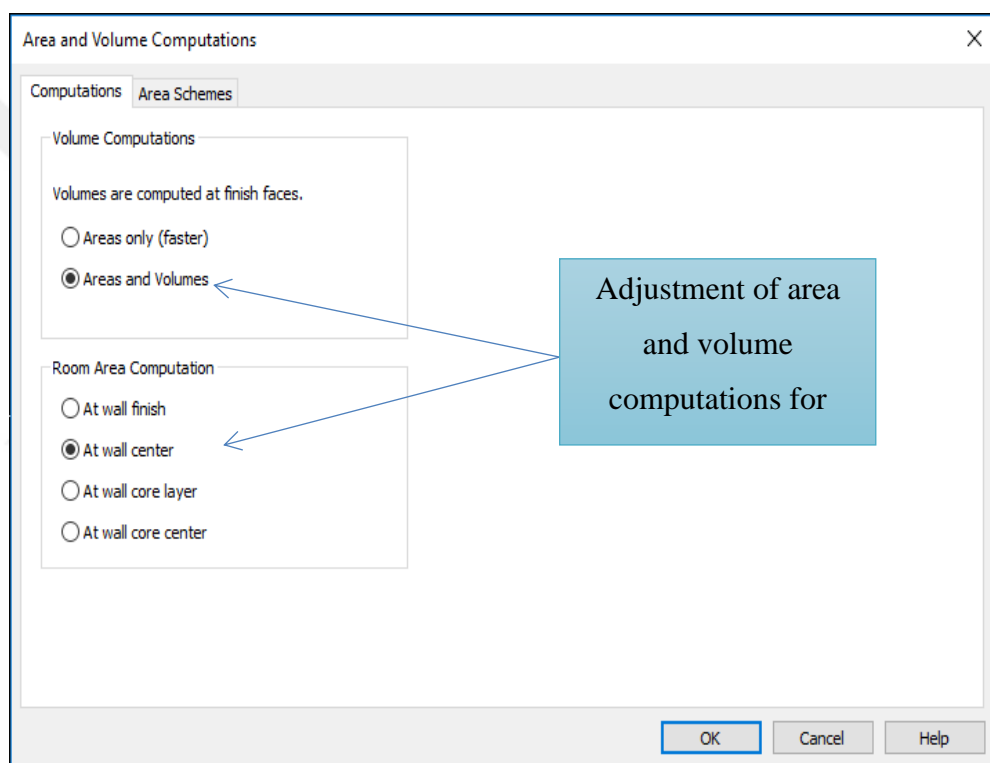

**Figure 6.3.** Room's area and volume computation setting

Another consideration the designers should put in account, is to make sure that the produced BPM is correct (see figure 6.4). This is because Revit determines room's volume at an identified height.

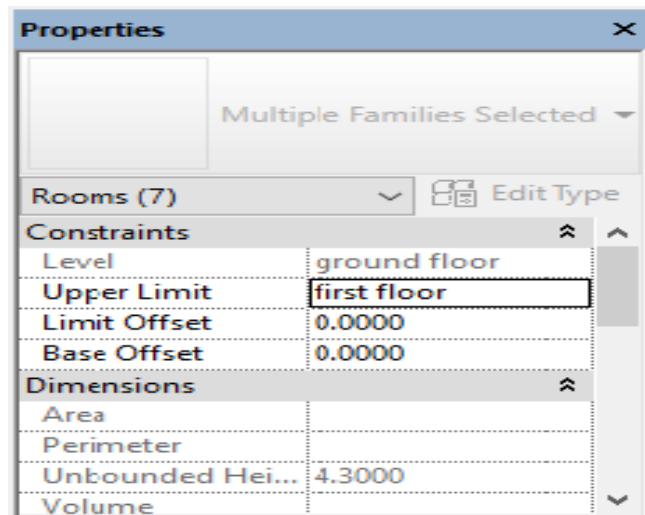
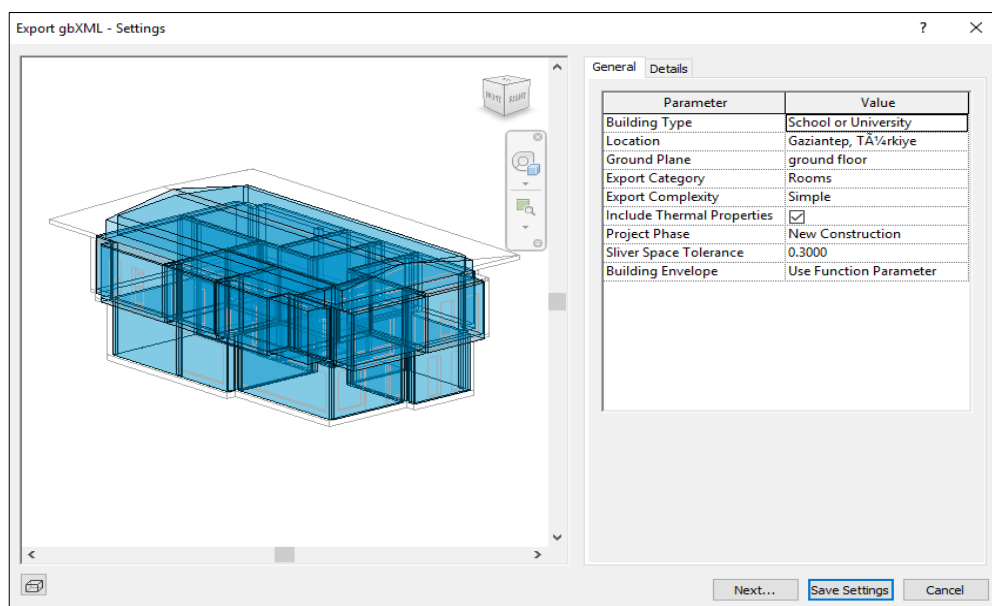

**Figure 6.4.** Setting the upper bound of rooms

It's important to properly define the upper bound of each room. As a general rule, it is better to set the Upper Limit for the Rooms to the next level and set the Limit Offset to zero.

### 6.1.3. Information exchange (data exporting process)

Once the building energy model is designed, the building model now can be exported to design builder software as a thermal model through the use of gbXML file (see figure 6.5).



**Figure 6.5.** Export setting of gbXML within Revit architecture

As its shown in figure 6.5, when exporting the building model, gbXML file provide a couple of options to be chosen, for instance, the building type, building location and export complexity depending on the type of the constructed building. Moreover, in Revit there is a dialog box with a preview of the exported model, this box is used to check whether the thermal zones are properly defined or not. Hence, the architectures can make sure that the analytical building design is correct by checking the details tab in the dialog box of the exporting process (see figure 6.6).

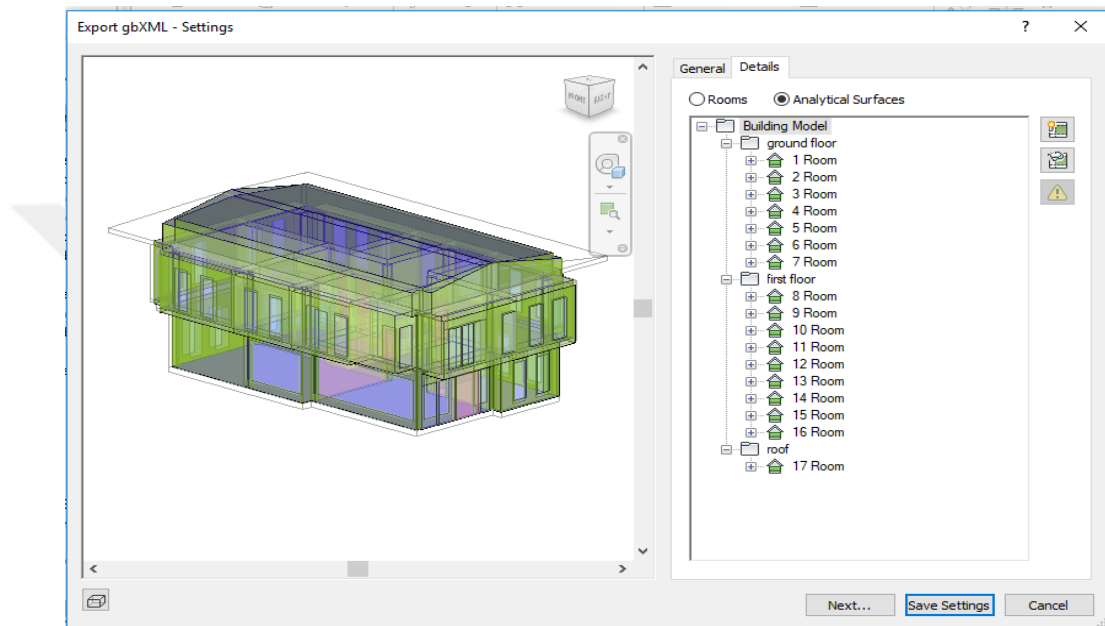

**Figure 6.6.** The details of correct analytical rooms

As shown in figure 6.6, when the green mark arises beside the rooms, it means that the rooms are correctly defined. On the other hand, when the yellow warning arises, it means that there is a problem with the physical properties such as area and volume of the rooms.

#### **6.1.4. Information exchange (data importing process)**

The building geometry now is ready to be imported in design builder software and analyzed. One thing is that design builder allows for importing a 3D building by using gbXML file format. During the importing process, design builder will give a preview of the building model and a few options like import thermal properties, import as a building block, import shaded surfaces, and merge coplanar surfaces. For this case study, all options are selected. In Design Builder, building blocks are used to define and organize various levels of building. Each block has one or more than one thermal

zone and building component like walls, roof, and floors are assigned to each zone. This will make a data hierarchy and building materials can be modified even at building block level or at component level. For instance, if the data of wall are changed at the block level, then all the walls included in that level will be changed according to that wall material. Figure 6.7 shows the selected gbXML file and a preview of building model respectively.

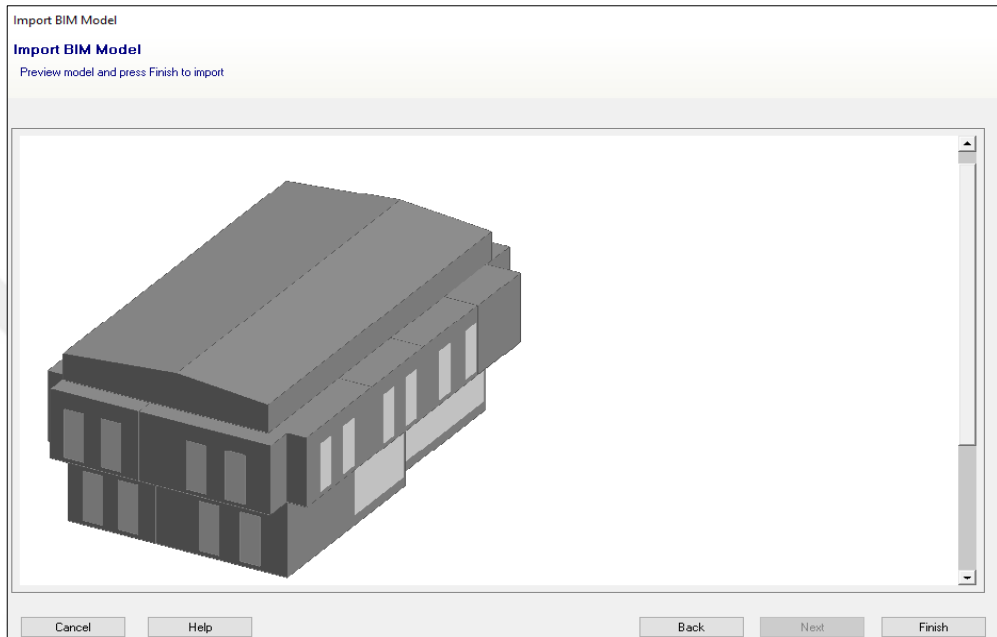

**Figure 6.7.** A preview of ARBIM building model

The final results of the building importing process are shown in figure 6.8.

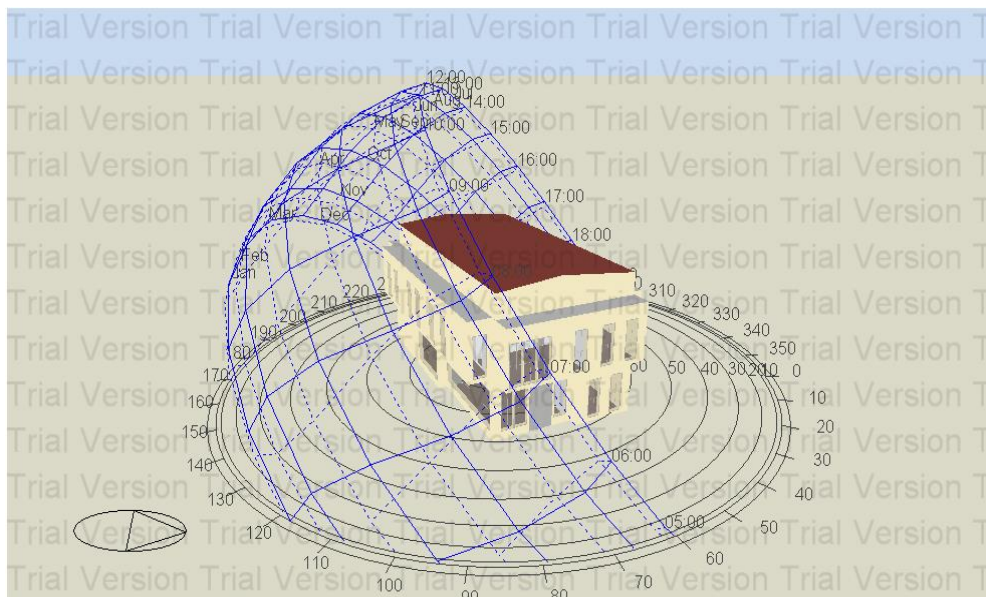

**Figure 6.8.** Rendered building model in design builder

As shown in figure 6.8, all the building seems to be correct and it's divided into three blocks, first floor block, second floor block and roof block. Design builder provides templates covering all the information needed about the building, those templates are: location template, activity template, opening template, lighting template and HVAC system template.

### **6.1.5. Energy model preparation in Design Builder software**

All the information related to physical properties of the building should be loaded in design builder software. This can be done by using the templates exist in the software. This is to define the actual properties of ARBIM building model and prepare it for energy performance analysis. The needed information can be classified into two categories: building location, orientation, and physical properties of the building construction elements including: external wall, internal wall, floors, roofs, glazing, lighting and HVAC system used in the building. Once the building properties is loaded, then the actual energy performance of the building can be calculated.

#### **6.1.5.1. Building location and orientation**

For ARBIM building, the location chosen was Gaziantep in Turkey. The longitude and latitude of the selected location are  $37.37^{\circ}$  E and  $37.08^{\circ}$  N respectively, the altitude is 832 meters above sea level, the site orientation is at  $330^{\circ}$ , which means that the front side of the building is east-north direction.

#### **6.1.5.2. The properties of building materials**

The physical characteristic of the construction elements and materials of the reference building are shown in table 6.1.

**Table 6.1.** The physical characteristic of building construction materials

Building components	Material layers	Thickness (m)	U- value (W/m <sup>2</sup> .k)
External wall	Natural stone- white	0.05	0.897
	Cement plastering	0.04	
	Aerated concrete block	0.2	
	Gypsum plastering	0.015	
Internal wall	gypsum plastering	0.015	1.225
	Aerated concrete block	0.1	
	Gypsum plastering	0.015	
Ground floor	Ceramic tile/porcelain	0.1	2.479
	Cement/mortar	0.044	
	Concrete cast (dense)	0.1	
Flat roof	Ceramic tile/porcelain	0.01	0.986
	Cement mortar	0.03	
	Glass wool	0.02	
	Concrete cast dense- reinforced	0.15	
	Ceiling tile	0.01	
Pitched roof	Clay tile roofing	0.025	2.930
	Air gap	0.1	
	Roofing felt	0.05	

In term of the type of window used in the building, the characteristic of materials are shown in table 6.2.

**Table 6.2.** The physical properties of the building exterior windows

Glaze type	Thickness (mm)	Frame type	Total solar transmission (SHGC)	U- value (W/m <sup>2</sup> .k)
Double Glazed 4mm with 12mm air gap	4	Aluminum	0.742	2.725

As shown in table 6.2, a double-glazed façade with no shade is used, it comprises of two layers of 4mm transparent glass with 12mm air gap. The frame used is aluminum window. Since the main aim is to optimize the building performance in term of energy efficiency, different design components will be simulated including building orientation, wall insulation, and window type. A couple of alternatives for each design components which are commonly used in Turkey will be considered for the simulation. This is to calculate the best energy performance for each design model to reduce building energy use and CO<sub>2</sub> emission.

### 6.1.6. ARBIM building analysis and results

The results of the ARBIM building case study can now be analyzed and discussed. In the first stage the actual building is analyzed to calculate the actual energy consumption as well as the amount of carbon produced by the building. Then, in the next stage alternatives is applied to the building in term orientation and building envelopes. Finally, these alternatives are compared with the actual building scenario. This is to choose the best building design in term of energy performance.

#### 6.1.6.1. Actual building energy performance analysis and results

The energy used, and CO<sub>2</sub> emitted by the actual building design are illustrated in both figure 6.9 and figure 6.10 respectively.

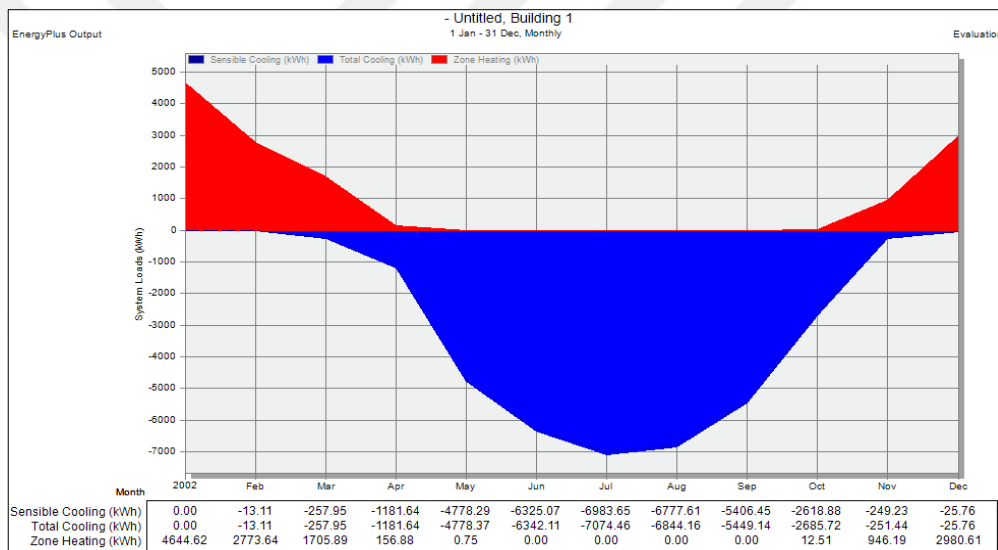

**Figure 6.9.** The monthly heating and cooling energy use for the reference building

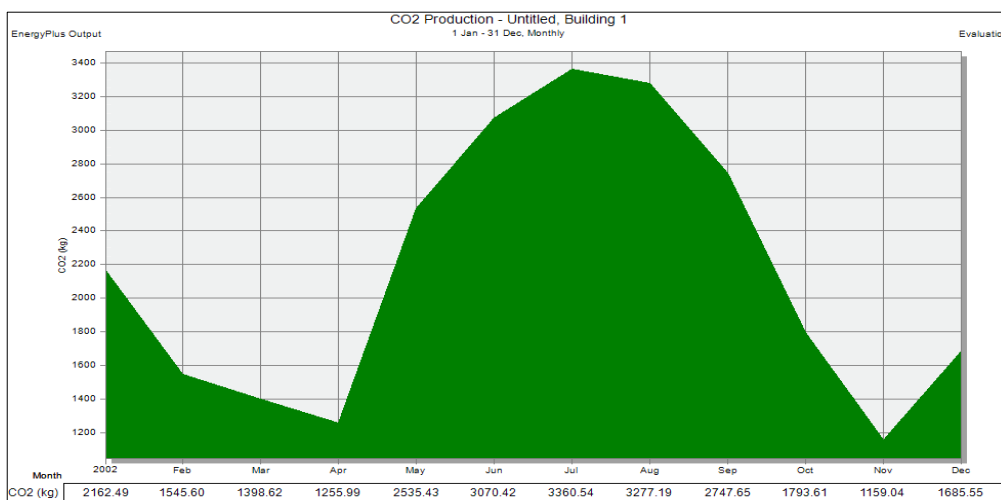

**Figure 6.10.** The monthly CO<sub>2</sub> emission of the reference building



As shown in figure 6.9 and figure 6.10, the calculated amount of annual heating and cooling energy use of the actual building design, are equal to 13221.09 (KWh), 34903.88 (KWh) respectively, making annual energy consumption equal to 48124.97 (KWh). While the annual CO<sub>2</sub> emitted by the building is equal to 25992.13 Kg.

#### **6.1.6.2. Performance values as environmental indicators**

As mentioned in the literature reviewed in chapter 2, the main factors which influence the building energy performance are primarily at building level. These factors can be divided into six major categories: building orientation, windows, external wall, roof, shading, openings, building architecture. Some of these categories will be studied and simulated for ARBIM case study, and the others will be taken for another case study in the next chapter.

As mentioned in chapter 2, climate is an essential element and has a significant effect on energy efficiency of buildings. That's why, buildings should be created according to local climate conditions. The analysis of local climate plays a significant role in the early design stage of buildings. Therefore, standards about building energy use and efficiency become important as protector of public health, safety and general welfare.

In Turkey, The most common standards used to ensure energy efficient buildings are known as the Thermal Insulation Regulation in Buildings (TS 825), which was published in 1998. But, it was applied as compulsory after June in 2000. However, most of the existing buildings in Turkey, have not fulfilled the requirements defined by (TS 825) standards (Yildiz, 2014).

The (TS 825) standards, defines the maximum heat transfer coefficients (U-value) for building components, such as external wall, ground floor and roof, based on the defined climate regions in Turkey (Dikmen, 2011). Accordingly, the maximum (U-value) for Gaziantep region are as follow: (0.6, 0.4, 0.6 and 2.4) for walls, floors, roofs and windows respectively. Thus, according the restrictions given in (TS 825) standards, it is possible to manage and control the U values of the building elements.

#### **6.1.6.3. The impact of building orientation on building energy performance**

The first step of building design optimization is to study and analyze the orientation of the building. The actual orientation is 330°, where the front side of the building is

facing east-north direction. 12 other tests were performed and simulated, by rotating the building 30° at each test. The annual energy consumption including cooling and heating energy consumption are calculated at each test and compared to the actual building energy consumption (see table 6.3).

**Table 6.3.** The impact of orientation on building energy consumption

<b>Orientation</b>	<b>Annual cooling load (KWh)</b>	<b>Annual heating load (KWh)</b>	<b>Annual energy consumption (KWh)</b>	<b>CO<sub>2</sub> Emission (Kg)</b>
330°	34903.88	13221.09	48124.97	25992.13
0°	33594.34	12577.04	46171.38	25334.10
30°	35588.92	12913.98	48502.9	26152.28
60°	37957.7	13184.42	51142.12	27084.9
90°	38551.1	13144.7	51695.8	27286.26
120°	38539.01	13447.72	51986.73	27369.56
150°	36590.23	13297.95	49888.18	26622.25
180°	34357.25	13067.00	47424.25	25748.56
210°	35472.36	13631.00	49103.36	26313.65
240°	36978.67	13933.47	50912.14	26943.82
270°	37102.86	13671.95	50774.81	26912.54
300°	36801.23	13690.12	50491.35	26810.73

As shown in table 6.3, the energy use of building at its actual direction will make an annual energy consumption equal to 48124.97 KWh and annual CO<sub>2</sub> production equal to 25992.13 kg, while when the building is at (0°) direction will perform the best in term of energy efficiency, making an annual energy use equal to 46171.38 KWh and annual CO<sub>2</sub> production equal to 25334.10 kg. This means that, when the building is facing (0°) direction, the amount of annual energy savings of both cooling and heating load is equal to 1309.5 KWh and 644.05 KWh respectively. While the annual reduction in CO<sub>2</sub> emission is equal to 658.03 Kg.

The question in this scenario is related to which direction of the building is appropriate to minimize the total energy consumption of the building. However, it is also necessary to take other criteria such as the view of the building.

Based on a study done by (Bektas, 2015), the required solar radiation data for passive utilization in building design is the intensity of the solar radiation on vertical surfaces. The indoor thermal environment is directly affected by the solar heat gains and losses through walls and glazed areas of the building envelope. Accordingly, an assessment on solar heat gain and losses for walls and windows will be explored and compared

for four main orientations north (0°), east (90°), south (180°), west (270°) and actual (330).

**In the first stage**, an assessment for wall heat gains and losses is investigated for two directions and then compared with each other. The first direction with long length walls facing north-south directions, and the second direction with long length walls facing east-west directions. Figure 6.11 shows the calculated heat gains and losses of building walls in both directions.

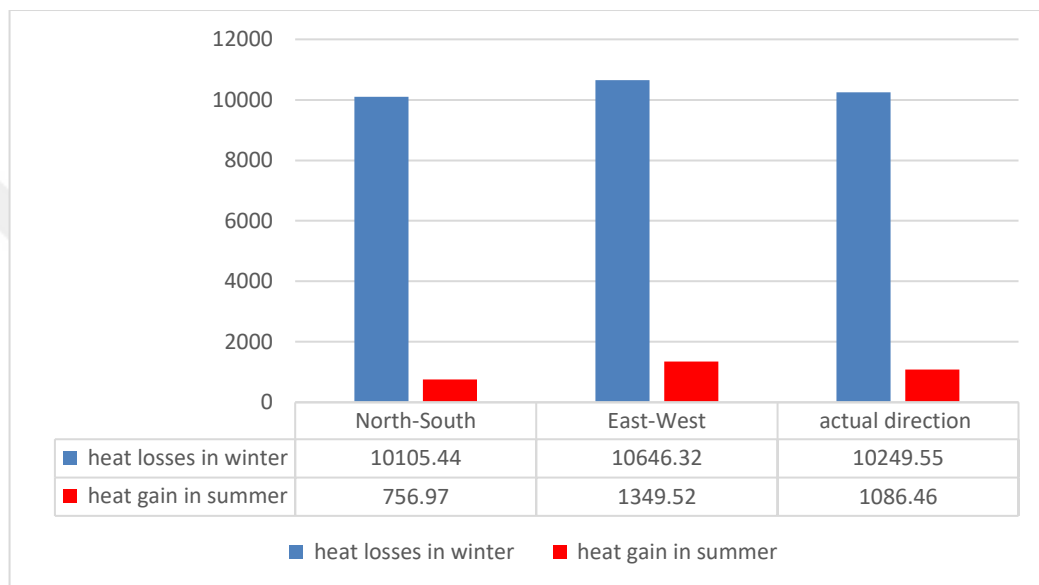
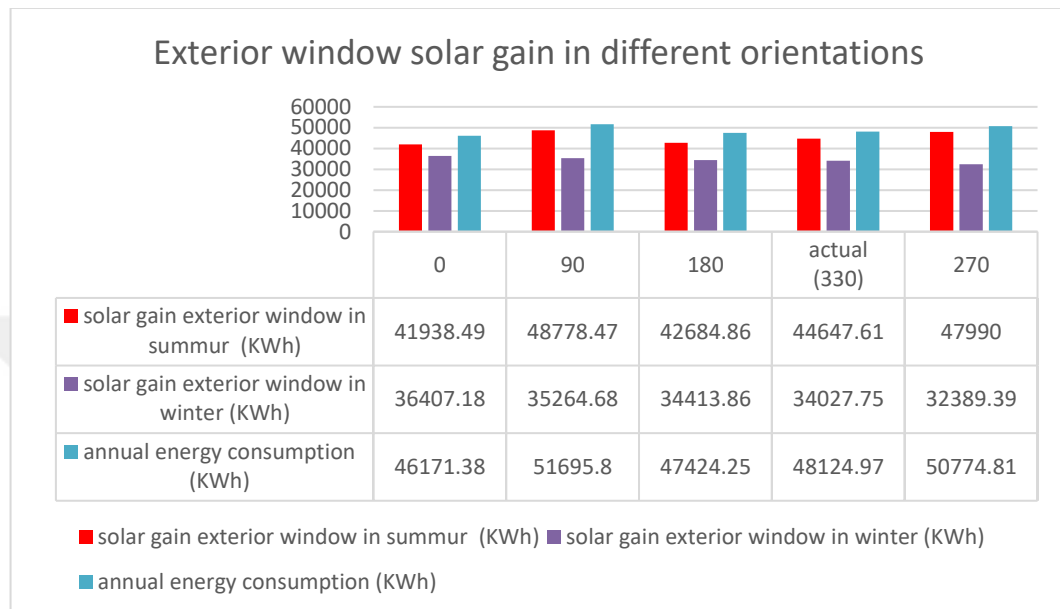

**Figure 6.11.** The heat gain and losses of walls in different directions

As shown in figure 6.11, when the long length walls are facing north south direction, less heat gain in summer will be achieved when compared to east-west direction, which means that less energy use is required to cool the building in summer, this is greatly due to the less of wall area exposed to sun heat. In winter, the heat losses of walls when the building long length walls are facing north-south direction will be less than east-west and the actual direction. This indicates that, less energy is needed to heat the building in winter. Based on these results, the walls with long length should be placed on north-south side of the buildings, while the walls with short length should be placed on east-west direction.

**In the second stage**, an assessment of heat gain through windows are investigated. Four main directions were compared to each other and to actual direction as well. To clarify how the glazing are stored on the building walls, when the building at (0°) direction, the glaze area of 49.89 m<sup>2</sup> and 40.98 m<sup>2</sup>, which are stored on the long length

walls, will be facing south and north side respectively, and the glaze area of 33.65 m<sup>2</sup> and 21.8 m<sup>2</sup>, which are stored on the short length walls, will be facing east west side respectively. The building was switched by (90°) degree, three times, in order to find the most efficient heat gain through glazing in both summer and winter. Figure 6.12 shows the window solar heat gains at different directions.



**Figure 6.12.** Window's solar heat gain at different direction

As shown in figure 6.12, when the building is at (0) direction, minimum heat gains through windows is achieved in summer period, and maximum heat gain is achieved in winter compared to the other directions. Therefore, to achieve efficient energy consumption, windows with bigger glaze area, should be placed on the long length wall facing south and north direction respectively, and façades with smaller glazed area should be placed on short length walls facing the east and west direction respectively. Consequently, the results indicated that, orientation has a considerable influence on building energy performance. However, the benefits of building orientation could be enhanced by taking in account other criteria such as: glaze insulation, window shading, and wall insulation. The conclusive results of the optimized building orientation are showed in figure 6.13.

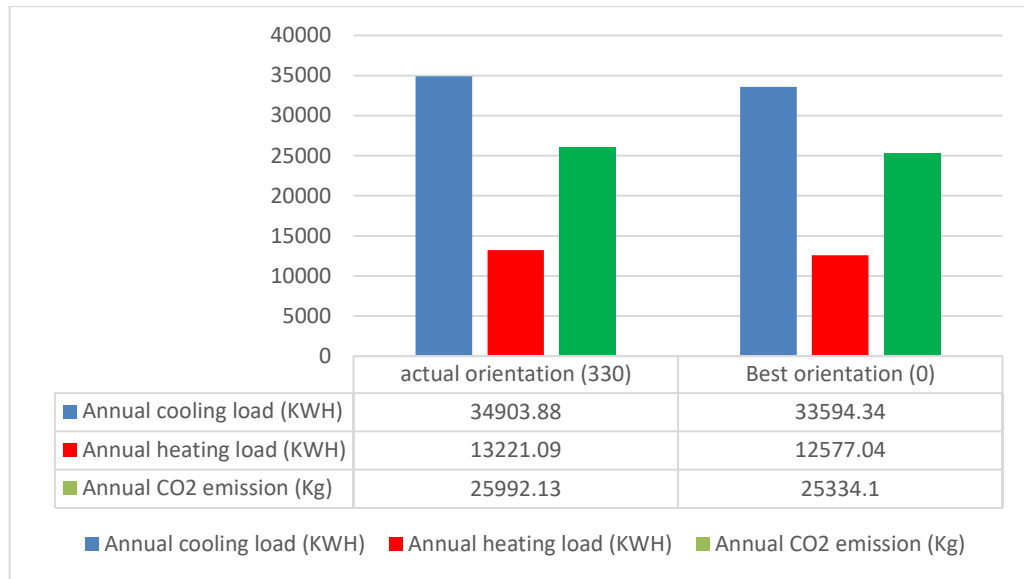

**Figure 6.13.** Heating, cooling energy consumption and CO<sub>2</sub> emission for the actual and optimized building orientation

As shown in figure 6.13, for the actual building orientation, the amount of cooling and heating energy consumption are equal to 34903.88 KWh and 13221.09 KWh respectively, and the amount of CO<sub>2</sub> emission is equal to 25992.13 Kg. While, for the optimized building orientation, the amount cooling and heating energy consumption are equal to 33594.34 KWh and 12577.04 KWh respectively, and the amount of CO<sub>2</sub> emission is equal to 25334.1 Kg. The implementation of the optimized building orientation will lead to energy saving equal to 1309.54 KWh and 644.05 KWh for cooling and heating respectively, and reduction in CO<sub>2</sub> emission equal to 658.03 Kg

#### 6.1.6.4. The impact of glazing on building energy performance

Many buildings in Turkey still have windows with poor thermal performances. For instance, 87% of building stock in Turkey has single glazed windows, 9% has double-glazing, and only %4 has low-e glazing (Maçka and Yasar, 2011).

For the actual building design, the type of glazing used is clear double glazed 4mm with air gap equal to 12 mm, and the type of window frame is aluminum. However, recently many other types of glazing have been produced such as (low-e coating glass) and (tinted glass). By using these glass alternatives, the heating and cooling loads of a building may be considerably decreased. Therefore, instead of 4mm transparent glass, absorptive and low e coating glass will also be simulated, to calculate, which glaze type and thickness is the more energy efficient one.

There are many variables that impact the energy saving potential of windows such as the type of climate, geometrical and thermal properties of the buildings in which windows are installed. (Karasu, 2010).

The window performance's parameters, which are simulated and evaluated for ARBIM building are: The coefficient of heat transmission (U value) and solar heat gain coefficient (SHGC). The glazing types with their thermal transmittance (U value, and solar heat gain coefficient) are presented in table 6.4.

**Table 6.4.** The U- values and SHGC values of the simulated glazing types

Double Glazing type	U- value (w/m <sup>2</sup> . k)	SHGC
4mm clear - 12mm -4 mm clear	2.866	0.742
4mm- 12mm- 4mm low E	1.771	0.591
6 mm clear -12mm- 6 mm clear	2.823	0.703
6mm clear-12 mm- 6mm tinted	2.828	0.482
6 mm clear- 12 mm- 6 mm low E	1.754	0.568

The calculated amount of cooling and heating energy use of the building for the five glazing types, including double glazing 4mm clear, double glazing 6mm low e, double glazing 6mm clear, double 6mm low e glazing and double tinted 6mm glazing are presented in table 6.5.

**Table 6.5.** The impact of glazing type on building energy performance

Double glaze type	Heating energy consumption (KWH)	Cooling energy consumption (KWH)	Annual energy consumption (KWH)	CO <sub>2</sub> emission (Kg)
4mm clear-12 air gap- 4mm clear	13221.09	34903.88	48124.97	28328.99
4mm clear-12 air gap-4mm low E	13069.39	29563.33	42632.72	24015.58
6 mm clear- 12 mm- 6 mm clear	13568.49	33655.08	47218.57	25641.56
6 mm clear- 12 mm- 6 mm low E	13346.00	28695.30	42041.30	23781.77
6 mm clear- 12 mm- 6 mm tinted	16665.60	25646.70	42312.30	23659.33

As shown in table 6.5, the rank of the simulated glazing from best to less impact will be as follows: double 6mm low e glazing, tinted glazing, and double low e 4mm glazing, double clear glazing 6mm, and finally double glaze 4mm.

When comparing Double glaze low e 6mm with double glaze 4mm which is used in the actual building, we will find that, the low e glaze has the lowest cooling load in summer, this is due to its low U value of 1.754 which describes the flow of heat from warmer place to cooler place. On the other hand, the heating load of double glaze low e is slightly higher than the heating load of double glaze 4mm. This is greatly due to its lower SHGC value of 0.568, which describes the percent of transmittance solar heat gain through windows. This means that the amount of solar heat gained by (low e glazing), is less than the amount of solar heat gained by double glaze 4mm clear, consequently, this will increase the heating energy use. Therefore, to decide on which type of glazing to be applied in the building, it's better to consider not only the U-value, rather, there is a need to consider the value of SHGC as well.

As shown in figure 6.14, when using (double 6mm low e) glazing, a significant amount of energy will be saved as well as less CO<sub>2</sub> production will be achieved. The annual energy saving achieved is equal to 6083.67 KWh and the annual reduction in CO<sub>2</sub> emission is equal to 4547.22 kg.

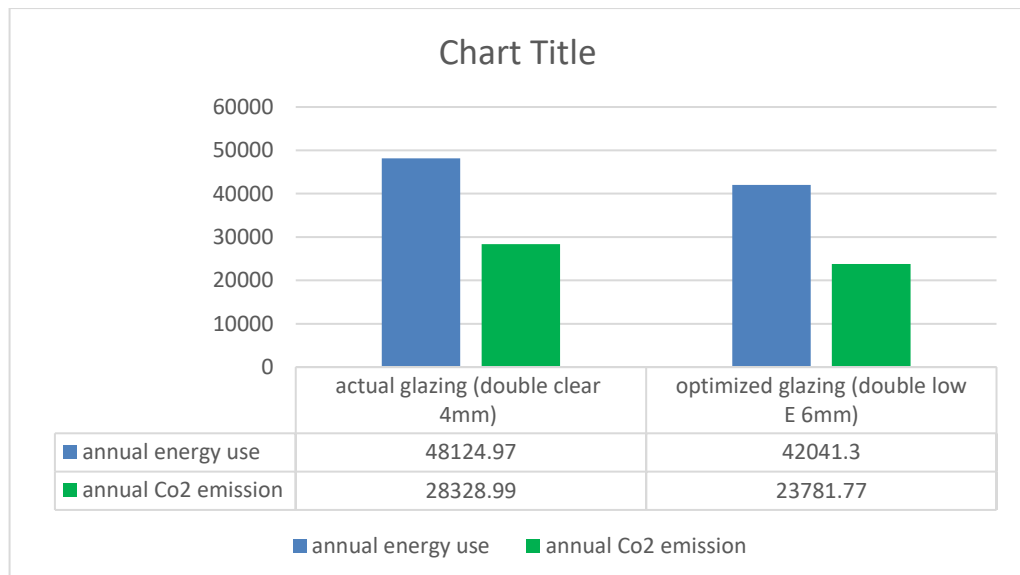

**Figure 6.14.** The impact of actual and optimized window on energy performance

Based on (TS 825) standards, the required u values of windows should not be more than 2.4. Therefore, among the simulated window types, only (4mm and 6mm double

low e) glazing can be applied for building in Gaziantep. Tinted window which has U-value 2.828 is energy efficient when compared to double clear glass. However, it's not recommended to be used, this is due to its U-value which is more than the required value sat by the (TS 825) standards.

Since the main aim is to achieve efficient building design by taking effective decision in the design stage, it's also necessary to consider the cost of energy when using all the glazing type mentioned above. For this reason, the researcher will make a comparison between the initial price of the simulated glazing and price of the energy consumption achieved by each of them. The cost of both window and energy price are obtained from websites and companies via internet. Table 6.6 shows a comparison between the initial cost of glazing and the cost of their energy performance.

**Table 6.6.** The impact of glazing type on annual energy performance and cost

Window double glaze type	Window area (m2)	Window cost (\$)/m2	Total Window price	Annual energy use (KWh)	Energy cost KWh/\$	Annual energy cost (\$)
4 mm clear	146.32	15	2184.8	48124.97	0.20	9624.994
4 mm low- e		18	2633.76	42632.72		8526.544
6 mm clear		16	2341.12	47218.57		9443.714
6 mm low- E		21	3072.72	42041.3		8408.26
6 mm tinted		18	2633.76	42312.3		8462.46

As it shown in table 6.6, the total price of 4 mm window which is used for the actual building design is equal to 2184 \$, making an annual energy cost equal 9624.994 \$. While, the price of (low E glazing) which is the most energy efficient one, is higher and equal to (3072.72) \$, but it will lead to less annual energy cost equal to 8408.26 \$. This means that, when replacing (double 4mm clear) glazing with (double low e) glazing, the initial design expenses will increase by 887.92 \$. On the other hand, the energy cost will be decreased by 1216.734 \$ for one year. In other word, the payback period of using (low e) glazing will be less than one year.



### 6.1.6.5. The impact of wall insulation on building energy performance

The major contribution of insulation materials in building envelope is significantly high and it has a significant role in enhancing the energy efficiency of the building. In the design stage, designers should concern about whether the use of insulation is needed or not, rather they should decide on which optimal type and of insulation is needed to achieve better energy performance. In other words, the use of insulation materials repay itself many times throughout the building life cycle. (Sisman et al., 2007).

Generally, many types of insulation materials are available now, the most commonly used types in Turkey are as follows: Expanded Polystyrene Foam (EPS), Extruded Polystyrene (XPS) and Rock Wool (RW) (Uygunoğlu et al., 2016). Therefore, three types of insulation material will be added to concrete aerated block, their impact on building energy performance will be calculated and compared with each other. Table 6.7, shows the energy performance of three types of insulation materials, including Rock Wool, Extruded Polystyrene and Expanded Polystyrene.

**Table 6.7.** The impact of wall insulation on building energy performance

<b>Aerated concrete block</b>	<b>U- value (w/m2. k)</b>	<b>Heating load (KWH)</b>	<b>Cooling load (KWH)</b>	<b>Annual energy load (KWH)</b>	<b>CO<sub>2</sub> emission (Kg)</b>
<b>No insulation</b>	<b>0.897</b>	<b>13221.09</b>	<b>34903.88</b>	<b>48124.97</b>	<b>25992.13</b>
4cm rock wool (RW)	0.509	10628.14	35290.85	45918.99	25278.80
4 cm-Extruded polystyrene (XPS)	0.408	10074.89	35304.96	45379.85	25124.36
4 cm-expanded polystyrene (EPS)	0.473	10433.73	35290.46	45724.19	25222.61

As shown in table 6.7, all the insulations material has an impact on building's energy performance. The rank of their effectiveness from best to less impact are as follows: Extruded Polystyrene (XPS), Expanded Polystyrene (EPS) and finally Rock Wool (RW).

The use of (XPS) has the best impact on the heating energy use compared to non-insulated wall, decreasing the annual heating load by 2787.36 KWh, because of its low u-value, which keeps the inside of the building warmer. While, the cooling load is slightly increased. This is greatly due the heat gained by windows, as well as the internal heat load generated by some equipment's used in the building. The (SHGC) value of the window system used in the building is relatively high (0.742). Consequently, the amount of transmitted heat inside the building will be increased, which in turn increases the use of cooling load.

As it shown in figure 6.15, the annual energy saving and CO<sub>2</sub> reduction when using (XPS) is equal to 2745.12 KWh and 867.77 Kg respectively.

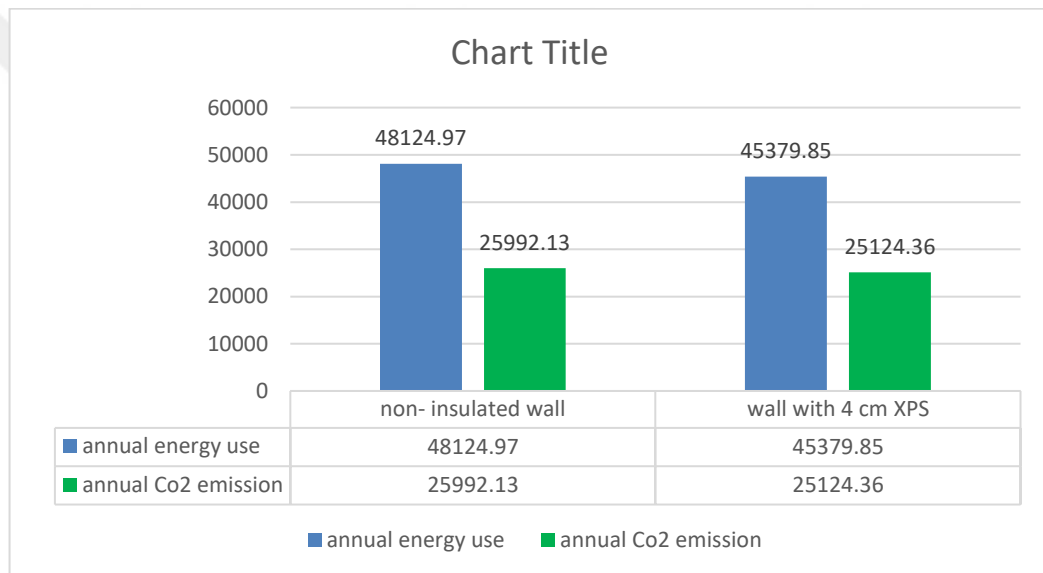

**Figure 6.15.** The impact of (XPS) on annual energy use and CO<sub>2</sub> emission

Similar to the glazing, the impact of wall insulation on building energy cost is investigated. Table 6.8 shows, the initial cost of each non- insulated and the three types of insulated walls and their impact on building energy cost.

**Table 6.8.** The impact of wall insulation on annual energy performance and cost

Aerated concrete block	Area (m2)	Insulation cost \$ / m2	Total Insulation cost	Total wall cost \$	Total energy use (KWh)	Energy cost/KWh	Total energy cost \$
No insulation	-	-	-	4145.68	48124.97	0.2	9624.99
4cm rock wool	514.09	1	514.09	4659.77	45918.99		9183.798
4cm Extruded polystyrene		5.5	3639.75	7785.43	45379.85		9075.97
4 cm EPS expanded polystyrene		3.82	1963.82	6109.5	45724.19		9144.84

As shown in table 6.8, the total cost of aerated concrete block used for the actual building is equal to 4145.68 \$, making an annual energy cost equal to 9624.99\$. While the price of the most energy efficient insulated wall (XPS) is higher and equal to 7785.43\$, but it will make less annual energy cost equal to 9075.97 \$. This means when adding 4 cm (XPS) to the wall material will increase the initial design cost by 3639.75 \$. However, on the other hand there will be an annual energy cost saving equal to 549.024 \$. In other words the payback period of using EXP insulation material will be around 6.62 year.

#### 6.1.6.6. Combination of optimum results- best practices

In this section, the best combination of the simulated design parameters will be defined as a best design decision to be made for the building. In the previous sections, the actual building energy performance is calculated, and then the simulation was run for different design parameters including: building orientation, glazing type and thicknesses, and finally wall insulation types. Each was done individually to find their impacts on building energy efficiency, and the results showed a notable decrease in both heating and cooling load of the building. The best practice methods are as follows (see figure 6.16):

- Building orientation: (0°) direction, in which long length walls are facing south and north direction, and bigger glaze area are stored at the long walls facing south direction.
- Glazing type and thickness: double glazing 6mm transparent glass /12 air gap/ 6mm Low e glass
- Wall insulation type: 4 cm (XPS) extruded polystyrene as external wall.

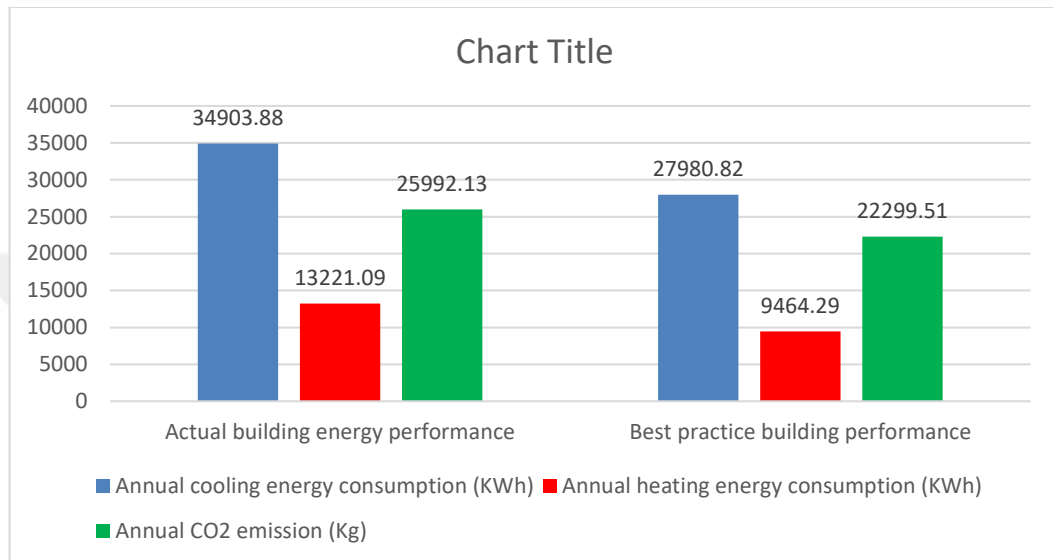

**Figure 6.16.** Building energy performance (best practice)

As shown in figure 6.16, the optimum selections of the simulated design parameters will lead to a significant energy saving. The cooling load is decreased by 20% from 34903.88 KWh to 27980.82 KWh, the heating load is decreased by 28% from 13221.09 KWh to 9464.29 KWh, and finally the CO<sub>2</sub> emission is also reduced by 14% from 25992.13 Kg to 22299.51 Kg.

## 6.2. The Design Optimization Process Components

As highlighted in chapter 5, there is a need to develop a design process modelling which sets a flow of activity and the responsibilities and roles of each actor involved, defines the process stages and information exchange requirements. This is to give a clear understanding of how design and optimization process can be done by the adopting of BIM in the early design stages.

Therefore, based on ARBIM case study, the researcher will identify and explore the design and optimization process components including stakeholders, process stages and tasks, and finally the information exchange requirements.

### 6.2.1. Stakeholders

The main issue in implementing building performance-based design is how to effectively incorporate various technologies that exist in multiple areas and provide a comprehensive performance analysis in a collaborative manner in the design process.. This comprehensive building performance analysis requires the integration of multiple domain participants including clients, architectures, engineers, and energy experts (Jeong and Kim 2016) and (Arayici, 2015).

To optimize the building performance, an early collaboration is highly needed between the actors at the early design stage. For instance, designers and engineer need to know what type of materials to use for a specific design, this can be done through reviewing the available materials with clients who will decide on which one to be used based on various aspects such as energy performance, economy, and aesthetic needs. Figure 6.17 shows the stakeholders involved in design process and their roles.

### 6.2.2. Process stages and tasks

The process map sets the boundaries of the information contained in the process, establishes activities in the process, and displays the logical sequence of activities and administrative information about the exchange requirements (Weise et al., 2009). This process describes the flow of activities within a particular topic boundary and the roles played by the relevant participants, as well as the information needed for those activities. Figure 6.17 shows the process stages for optimizing building design which identify the stakeholders involved in the process, as well as the stages and tasks required to achieve best design alternatives. These activities are explained below:

**Stage 1: Review building design and alternatives:** clients at the first stage will receive the energy performance results for the actual building design and suggest some alternatives in a collaborative manner with architects and engineers based on the materials availability, aesthetic and economic requirements.

**Stage 2: Prepare and check the selected alternatives for energy analysis:** at this stage, the architects will create 3D building model by using Revit architecture. They also will prepare the building materials alternatives chosen previously, and then the building design model and alternatives will be transferred to the energy experts for energy performance analysis.

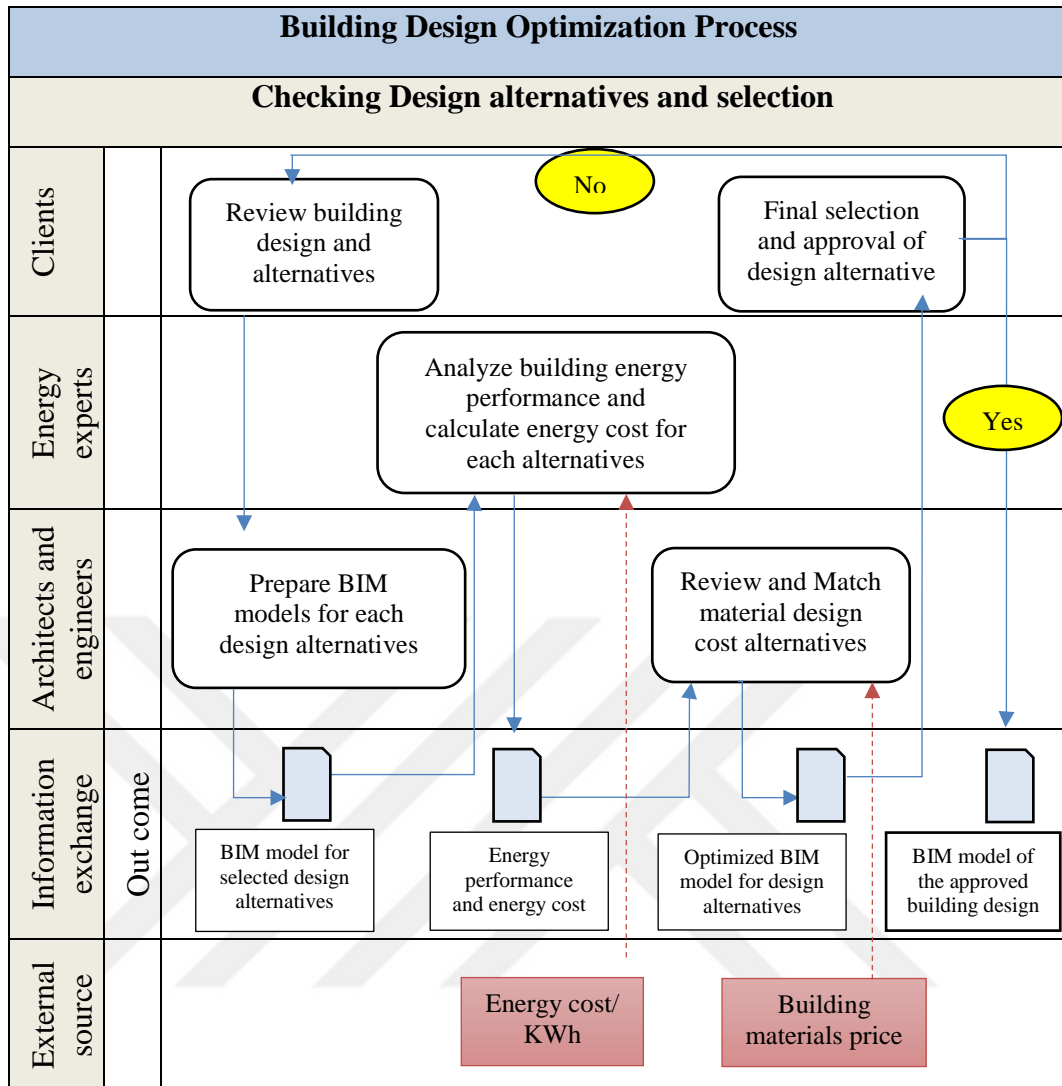

**Figure 6.17.** Stakeholders and Design process stages and tasks

**Stage 3: Analyzing actual building energy performance and alternatives:** in this stage the energy expert will analyze the actual building model as well as the alternatives provided by the architectures and calculate the energy performance for each one. In this regard, Design builder energy software was used to determine the amount of energy consumed for each design alternatives. Once the energy performance is determined, then the total energy cost for each design alternatives will be calculated.

**Stage 4: Review design alternatives with energy performance and cost results:** The engineers and architects will receive the simulated and analyzed building models with their calculated energy performance and energy cost. Similarly, they will calculate the cost of material alternatives. Then, they will make some changes and optimize the design model based on the energy performance, energy cost and materials cost of each design alternatives.

**Stage 5: Final selection and approval of a design alternative:** in this stage the clients will receive all the information related to the proposed design alternatives, they will compare and analyze BIM models established earlier, and then they will choose the best model alternative based on economical, energy efficiency, and aesthetic requirements. Finally the chosen alternative is then shared via virtual collaborative workspace.

Based on the process explained in the figure above, a passive and active design strategies could be implemented for any building design. This design process workflow makes it easy for the engineers and designers to explore and study different design alternatives. Consequently, efficient and good design decisions could be achieved which ensures energy efficient building design.

### **6.2.3. Data and information exchange requirements**

The next step is to identify the information exchange and its content together with information exchange requirement which specify the information exchange and its contents with the information exchange requirements which characterize the link between process and data. It holds the related data to guarantee a proper data exchange among the two actors and their corresponding tasks in the integrated process (Berard and Karlshoej, 2011) and (Belsky et al, 2014). Figure 6.18 shows the information exchange requirements between actors involved in the design optimization process.

Typical workflow and information exchange between BIM and energy analysis software requires exporting building models from BIM to analysis software applications. Appropriate method for data and information exchange between BIM and energy software depends on the analysis goal and what kind of information is required. As shown in the figure above, the data and information exchange from Revit architecture to design builder accomplished by using gbXML file.

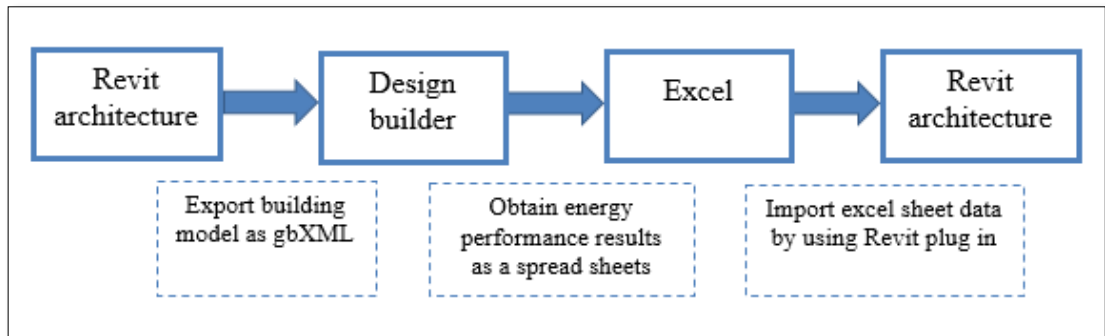

**Figure 6.18.** Data and information exchange requirements

Once the model is imported in design builder, the results of the simulation can be obtained in different forms such as tables, figures and spreadsheet. Hence, transferring the analysis results back into BIM is challenging. Thus , a custom-built plug-in for the Revit platform is established, that lets importing the analytical results, such as building orientation and envelope materials energy performance results, into BIM design model. It allows transferring of data via Excel spreadsheets based on the numeric values obtain from design builder (see figure 6.19).

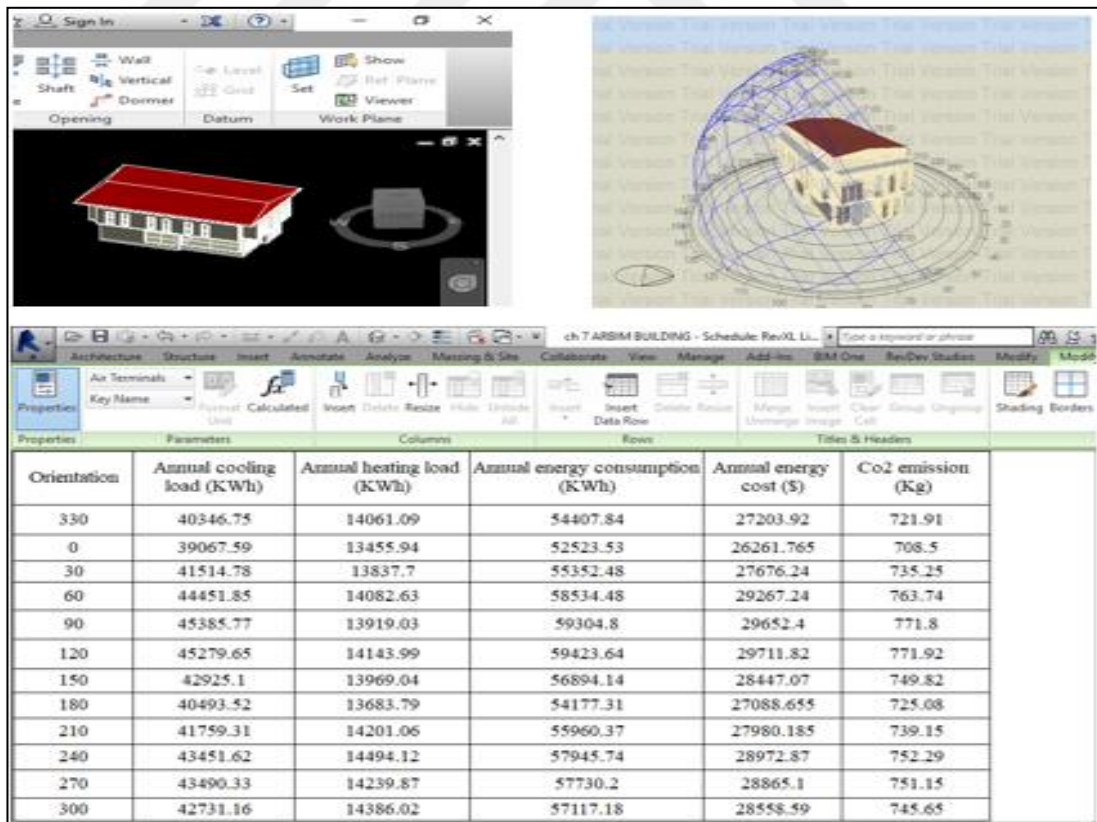

**Figure 6.19.** Exporting data results into excel sheet and importing it into Revit by using Revit excel importer



As shown in figure 6.19, the process of information exchange was tested for building orientation, where the building first is exported as gbXML from Revit to design builder to analyze different orientations and calculate the building energy performance at each test, then the calculated results were exported from design builder to excel sheet. Once the data is imported into excel sheet, then the total energy cost were calculated and finally imported into Revit by using Revit-excel importer, which it has been downloaded from application store of Revit.

### **6.3. Technology Implementation: PV Technology**

In the previous section, the aim was to identify the design and optimization process through integrated BIM use. Meanwhile, different design strategies were implemented such as building orientation, and envelope materials in order to optimize building energy performance.

The next further reduction of total energy consumption will be realized by using renewable energy technologies. Many simulations showed that, it is impossible to achieve comfort standards without using auxiliary heating or cooling system. The ability of active systems which use solar energy as a renewable energy source present an important research area for the region. Therefore, in this section the process of PV technology design will be explored, and the main parameters and their impacts on the PV performance will be studied.

As explained in the chapter 2, Turkey is the third largest solar thermal power plant in the world. However, in term of solar potential, the building integration of renewable energy such as solar panels is not successful enough.. Therefore, in this section, there will be an explanation of how to successfully design and integrate PV panels for ARBIM building case study by using design builder to reach a maximum energy use reduction in the building starting from the design phase.

As mentioned by (Dos Santos and R  ther, 2012), to optimize the performance of PV systems on buildings, the orientation of PV arrays and PV's tilt angles are a main concern, as the design of the system and electrical system design and electrical formation must increase sunlight exposure. For this reason, different orientations and tilt angles of PV will be tested and simulated for ARBIM building, the determined energy generation by PV system will be evaluated at each test and compared with each

other, and this is to achieve the most efficient PV performance. To calculate the energy performance and the impact of (PV) technology system regarding existing building, we will implement the following steps:

- Creating the PV module by using design builder.
- Calculating the yearly energy consumption of the building.
- Calculating the yearly energy generated by PV system.

At first, an integrated design approach will be explored of solar photovoltaic (PV) system by using design builder software. Then, the annual energy consumption of the building will be calculated. Finally, the annual energy generation of PV system will be determined. This will be done by considering the performance-based parameters including various PV orientation and different tilt angles of the modules and their impact on the annual energy generation will be defined and compared with each other to find the most optimum one.

### **6.3.1. Modelling solar photovoltaic (PV) system by using Design Builder software**

In this study, solar photovoltaic (PV) system, which has a great ability in supplying energy and CO<sub>2</sub> reduction are considered. Roof applied PV system was calculated to analyze the energy performance of PV systems according to the climatic conditions of turkey- Gaziantep. The type of PV technology used is called crystalline silicon (c-Si), installed on a pitched roof structure, covered the roofing tiles of the ARBIM building.

Design builder is used to create the PV modules. The required steps to design PV system are as follows:

- 1- Geometric model development for the solar PV arrays.
- 2- Assigning electrical performance model to the solar PV array.
- 3- Creation of PV electrical performance model by using and actual manufacturer specification.
- 4- Include electrical load center to model DC-to-AC inverter equipment.

#### **6.3.1.1. Geometric model development of solar PV module and array**

To design a PV module and assign the electrical performance to the system, there is a need to adopt an actual manufacturer's specification. As mentioned above the type of PV modules considered is poly crystalline. To design a PV modules and assign the

electrical performance to module, the researcher will adopt an actual manufacturer's specification. The PV module type selected for this study and its physical properties are shown in figure 6.20.

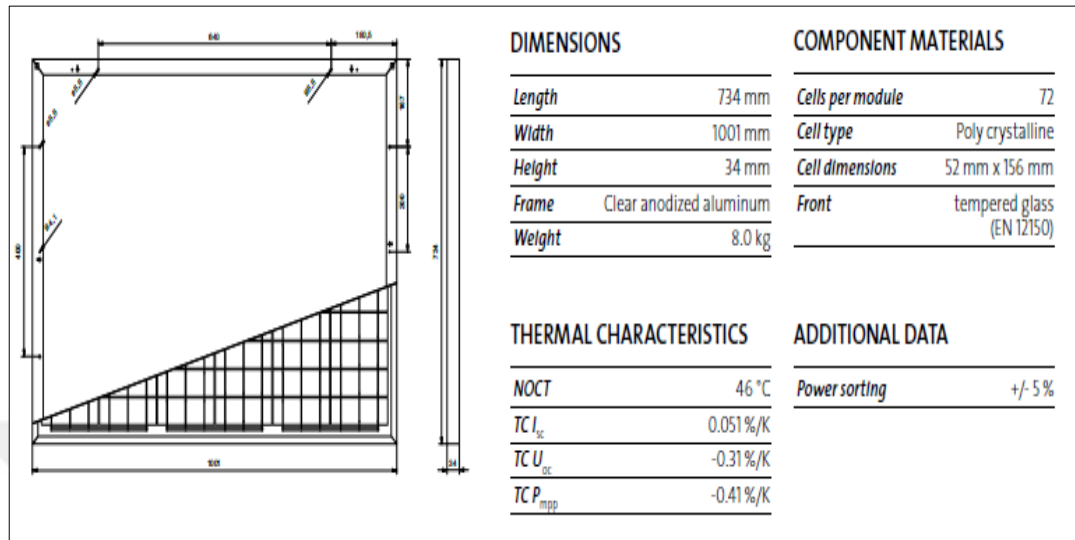
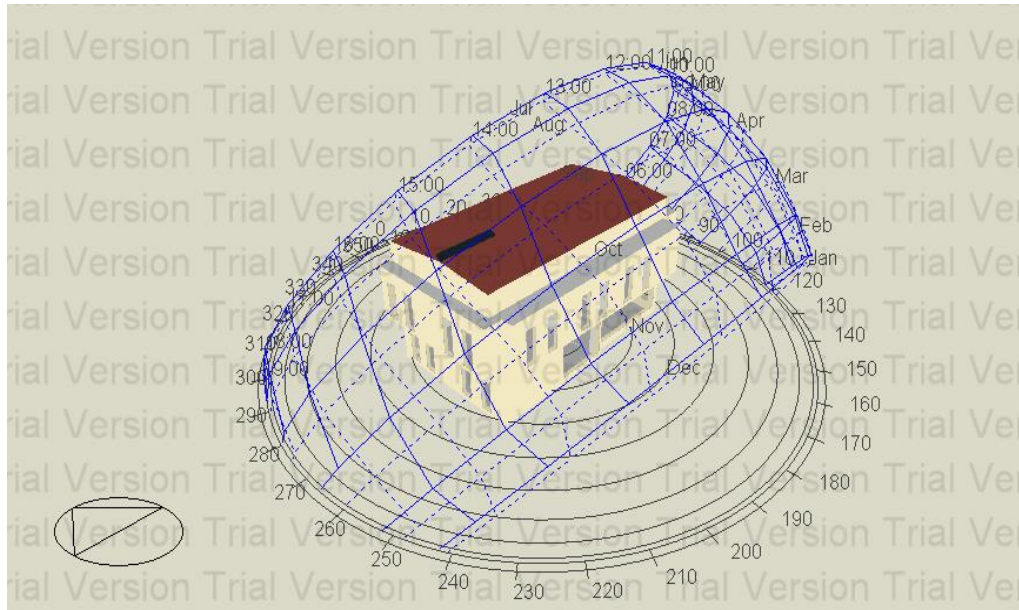

**Figure 6.20.** The physical characteristic of the PV module

The cell dimensions are (0.052m \* 0.156m), and the number cell per module is equal to 72 cells, accordingly, we can calculate the module area by multiplying the cell dimensions by the number of the cells per module:

$$\text{PV Module area} = (0.052 * 0.156 * 72) = 0.584064 \text{ m}^2$$

Using detailed geometry generation tool of design builder's graphical interface, a PV module can be created, also the PV array area can be generated by multiplying the PV module by an integer number. In this study, we will assume that there will be (1) PV array which comprises of (5) PV modules (see figure 6.21). Therefore, to find the PV array area, we will just multiply the determined area of the module by the number of the module we assumed in the array: PV array area= 0.584064 \* 5= 2.92 m<sup>2</sup>.

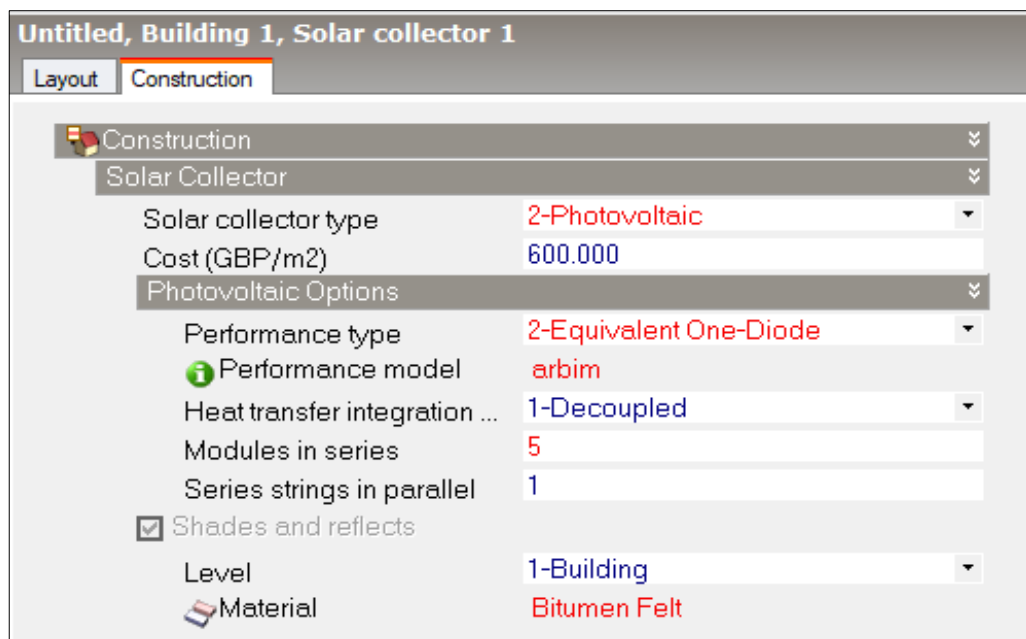

**Figure 6.21.** Sun path diagram of ARBIM building integrated PV panels

As shown in figure 6.21, one PV array panel geometry of 2.92 m<sup>2</sup> area is created and attached to the roof of the building.

### 6.3.1.2. Assigning electrical performance model to the solar PV array

Once a solar collector surface has been created and placed on the building, we can define its properties on the Constructions tab under the Solar Collector header (see figure 6.22).



**Figure 6.22.** The properties of the PV selected for the building

As shown in figure 6.22, all the properties including PV type, selected performance model, and the number of modules in array are entered.

### 6.3.1.3. Creation of (PV) electrical performance model

To create the PV electrical performance, there is a need to use an actual manufacturer specification. The type of the information used to create the performance model is shown in figure 6.23.

PERFORMANCE UNDER STANDARD TEST CONDITIONS (STC)*		
SW 100		
Maximum power	$P_{max}$	100 Wp
Open circuit voltage	$U_{oc}$	44.2 V
Maximum power point voltage	$U_{mpp}$	37.6 V
Short circuit current	$I_{sc}$	3.02 A
Maximum power point current	$I_{mpp}$	2.75 A
Measuring tolerance ( $P_{max}$ ) traceable to TUV Rheinland: +/- 2% (TUV Power controlled)		*STC: 1000W/m <sup>2</sup> , 25°C, AM 1.5
PERFORMANCE AT 800 W/m <sup>2</sup> , NOCT, AM 1.5		
SW 100		
Maximum power	$P_{max}$	72.7 Wp
Open circuit voltage	$U_{oc}$	38.9 V
Maximum power point voltage	$U_{mpp}$	33.1 V
Short circuit current	$I_{sc}$	2.46 A
Maximum power point current	$I_{mpp}$	2.20 A
Minor reduction in efficiency under partial load conditions at 25°C: at 200 W/m <sup>2</sup> , 100% (+/-2%) of the STC efficiency (1000 W/m <sup>2</sup> ) is achieved.		

**Figure 6.23.** Electrical specification of poly crystalline PV technology

It can be noticed that there are two standards namely STC (standard test condition) and (nominal operating cell temperature) NOCT. STC represent the laboratory conditions while NOCT seems to simulate the real-life conditions. However, in this study the STC standards were adopted to develop the PV model performance.

As mentioned Ordenes (et al., 2007), it is necessary to consider the various light to electricity conversion efficiency and operating temperatures characteristics in the design of PV system. The nominal output characteristics of PV modules are given in the standard test conditions (STC), and in term of the impact of temperature on PV modules Efficiency, we considered the nominal operating cell temperature (NOCT).

All the information needed to create PV model is given in figure 6.23. Accordingly, the electrical performance model of PV system can be created in design builder (see figure 6.24). It shows all the inputs that we need to create the model, the number in red color were all obtained from the specification explored in figure 6.23.

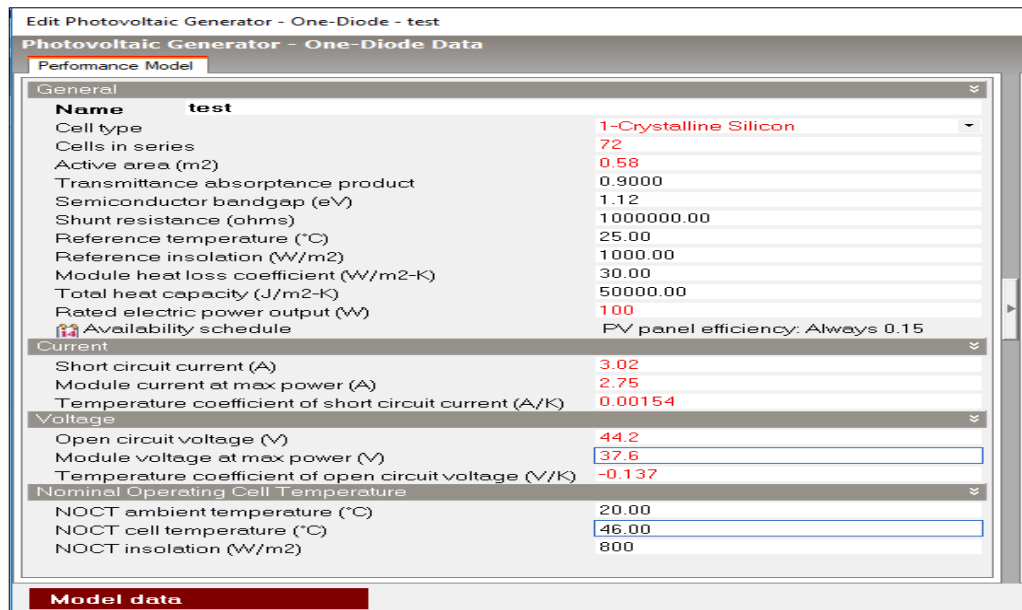

**Figure 6.24.** PV electrical performance model

#### 6.3.1.4. Including electrical load center to the model (dc-to-ac) inverter equipment

Once the electrical model performance is created, the electrical load center for the PV module should be included. In design builder we propose the number electric center load is equal to (1) because we have one PV array, the type of inverter is (DC with inverter), and the inverter efficiency is equal to 96%. In this regard, the PV module will be ready to be simulated and calculate the annual electrical generation.

#### 6.3.2. Calculating the annual energy consumption of the building

Table 6.9 presents the total energy consumption of ARBIM building including cooling, heating, lighting and internal equipment.

**Table 6.9.** The annual electricity demand of ARBIM building

Total conditioned building area (M2)	Annual electricity (lighting and internal equipment) (KWH)	Annual cooling consumption (KWH)	Annual heating consumption (KWH)	Total energy consumption (KWH)
452.91	15488.01	27980.82	9464.29	52933.12

Regardless of the cooling and heating energy consumption, there are other types of energy consumed by the building such as lighting and the internal equipment. Since

this study aims at finding the amount of electricity generated by PV system, therefore, only the electrical energy including lighting, equipment's will be considered. Because, in design builder the efficiency PV modules is determined based on the electricity consumed for lighting and internal equipment. The cooling and heating energy consumption is not considered.

### **6.3.3. Calculating the annual electricity generated by PV System**

After modelling the PV array and calculating the annual electrical energy consumed by the building, we can now calculate the annual electricity generated by the design PV panel. Since, the main aim is to achieve efficient energy generation of PV array, three types of analysis will be running by using design builder. The first analysis is about finding the optimum orientation of the PV modules. In this regard, eight scenarios are applied for one PV module of area equal to (2.92 m<sup>2</sup>), this is to find out the best position of the PV modules on building's roof. The second analysis is about determining the best tilt angles of the poly crystalline PV array. To carry out this analysis, different angles of the PV module were examined and simulated in term of total energy generation. The analysis was performed at angles of (0° to 90°) degree with interval of 10 degree. As a result, the optimum tilt angle of the PV modules regarding turkey's climate zone is calculated. The third analysis was about calculating the best space between the PV module's rows, this is to reduce the electricity generation loss caused be mutual shading, thus determining the optimum PV module generation. For this reason, two PV array each of 5 modules are simulated at different row distances starting from (0) to (2.5) m distance with interval of (0.5). As a result, the best row distance of PV arrays regarding turkey's climate will be achieved.

### **6.3.4. Results**

The results of PV orientation and tilt angles can now be calculated and discussed

#### **6.3.4.1. The impact of PV array orientation on total electricity generation**

The first analysis carried out is about finding the best orientation for the PV array. The PV array was first placed at north direction and then rotated 8 times, each at 45 degree, the amount of electricity generated are calculated at each orientation, in order to find the best one (see table 6.10).

**Table 6.10.** The PV electricity generation of different PV orientations

PV orientation	PV area (M2)	Electricity generated (KWH)	Electricity generated/electricity consumed %
North	2.92	533.19	3.44
North- East		637.06	4.11
East		830.25	5.36
East- south		983.44	6.35
south		1046.31	6.76
South- west		1003.35	6.48
West		816.55	5.27
North west		663.14	4.28

As shown in table 6.10, the annual generation of PV system for eight different direction are calculated. It's clear that PV array with south orientation are making the maximum electricity generation among the other which is equal to (1046.31) and satisfies 6.76% of the total electricity consumed by the building. While, the PV array will perform the worse when it placed at north direction, making 533.19 KWh which satisfy only 3.44%, equal to the half of that generation at south direction.

#### 6.3.4.2. The impact of PV tilt angle on total electricity generation

The second analysis is performed to find out the optimal tilt angle of the PV array. Different tilt angles starting from (0 to 90) with interval of 10 degree were examined and simulated to find out the best tilt angle of the PV array. The results are presented in table 6.11.

**Table 6.11.** The PV electricity generation of different PV tilt angles

Tilt angle of the PV array (degree)	PV array area (M2)	Electricity generation (KWh)	Electricity generated/electricity consumed %
0°	2.92	946.87	6.11
10°		1006.64	6.50
20°		1045.29	6.75
30°		1062.19	6.86
35°		1062.39	6.86
40°		1057.14	6.83
50°		1030.39	6.65
60°		982.59	6.34
70°		914.97	5.91
80°		829.49	5.36
90°		729.91	4.71



As shown in table 6.11, the optimum tilt angle for the PV array is at angle of (30°) degree which makes an annual electricity generation equal to 1062.19KWh, and it satisfies around 11.6% of the total electricity consumed in the building. While the worse performance was at tilt angle equal to (90°) degree, which makes an annual generating equal to 729.91 KWh satisfying only 4.71% of the annual building energy demand.

#### 6.3.4.3. The impact of PV row distance on total electricity generation

The third analysis is conducted to find the best row distance for two PV array. The first simulation was performed at (0.5) distance, then the distance was increased (0.5) m at each scenario until it reaches (2.5) m. the results are presented at table 6.12.

**Table 6.12.** The impact of PV row distance on annual electricity generation

Distance between PV arrays (m)	PV arrays area (M2)	PV generation (KWh)	Electricity generated/ electricity consumed %
0.5	5.84	2113.21	13.64
1		2118.07	13.68
1.5		2121.41	13.70
2		2123.72	13.71
2.5		2123.77	13.71

As shown in table 6.12, the row distance of (0.5m), makes the lowest energy generation, this is mainly due to the partial shading caused by the self-shading of PV array rows over the other. It's also shown that, there is no remarkable energy generation differences for the simulated PV arrays when the row distance increases from 2 m to 2.5m, this is mainly due to negligible effect caused by the self-shading of the modules. Thus, distance of 2 m between the PV arrays is the most efficient one in term of energy generation and mutual shading avoidance.

#### 6.4. Conclusion

In this chapter, an attempt was made to identify and explore the first two components of the hypothetical framework: design and optimization process, and the implementation of PV technology.

Based on the analysis and simulation results of ARBIM building case study, the relationship between building energy performance simulation and design process, and

how making predictions on building performance will help in finding strategies to reduce energy consumption and enhance building performance were discussed. Furthermore, the design process components including, the stakeholders involved in the process as well as their roles and responsibilities during the design stage were identified, this was followed by identifying the process tasks and stages required to reach better decision during the design stage.

The methods and ways needed for information exchange between BIM and energy analysis software (Design builder) were also identified, ensuring how it important to differentiate between BIM design models and analysis models. The interoperability between BIM based design and simulation software can enhance the workflow between design documents and analysis applications, where data and information exist in the model can be used for analysis process as well. However, it is necessary to manage and properly develop the BIM design models and analysis models need to be managed and properly developed, considering the stakeholders involved, process stages and the information exchange during the process. It is also significant to know what sort of data and information is necessary for a specific analysis, and how effectively using BIM to simulate design alternatives.

In the second section, a detailed procedure was explored in order to identify the required design steps of solar photovoltaic (PV) system in term of PV orientation, PV tilt angle, and row distance of PV array. This is to enable implementing it for both existing buildings and new construction building design in Turkey. Furthermore, it could be crucial at keeping the economic growth sustainable in turkey.

Design builder was used to design the solar PV system, and to carry out different analysis about the energy generated by PV system. Consequently, the study was successful in proving that, PV module orientation, tilt angle, and row spacing influence the total energy generation and should be considered when designing PV system for a building. Thus, the main finding of this study are as follows:

- The orientation of the PV modules must be chosen carefully before deciding it's place, this to make a maximum energy generation. Different orientations were tested, the result showed that PV modules with south orientation perform better than the others, which generate an annual electricity equal to (1046.31Kwh) for one PV module (area= 2.92 m<sup>2</sup>).

- The second analysis was about PV tilt angles, different angles were analyzed starting from (0°-90°) degree with 10° degree interval. The results showed that, tilt angle of (30°) degree is the optimum tilt angle to be implemented, making annual electricity generation equal to (1062.19 KWh) for one PV module
- Row distance of PV array should be taken in account when designing more than 1 PV array. Row distance of more than (2) m has no real impact on the annual energy generation, maximum generation is provided at 2 m.



## **CHAPTER 7**

### **BUILDING DESIGN RULES AND LOCAL ENERGY ASSESSMENT SCHEME REFLECTING LOCAL VALUES**

In this chapter, the other two components of the proposed hypothetical framework will be undertaken and identified. These components are building design rules and ontology and local energy performance assessment scheme reflecting local values. This will be done through conducting an ecological (passive house) building case study in Gaziantep-Turkey.

In general, designing an energy efficient building have become a target to be achieved in different countries. Therefore, there was a general movement toward finding effective ways and strategies to decrease the energy use of buildings and to promote more awareness of energy efficient design (Tabesh and Begum, 2015). To achieve this target, a great attention must be paid towards building design decisions and methods to make significant improvements in buildings energy performance.

In this chapter, we will investigate the possibilities of adopting sustainable and ecological design strategies. To do that, a passive house building case study will be conducted, and then different design strategies will be examined throughout the consideration of different design criteria from building's orientation to building materials choices. Thus, preparing a reliable and easily accessible design guide that could be easily applied by designers to create an efficient building design considering the local environment values, changing the way designers think about information they use in the design and assessment process of buildings, thereby enabling sustainability of buildings.

In addition, an energy assessment scheme will be created similar to those used at global level such as LEED and BREEAM. This local assessment scheme enables determining and calculating the level of success in implementing the rules related design strategies considering local values.

## **7.1. Ecological Building Design Criteria and Strategies**

Ecology is a discipline that deals with the association between organisms and the environment. It is also defined as sub-areas of environmental science, including ecological building design (Bekar, 2007).

Ecological or passive buildings can achieve the lowest energy requirements by enhancing the heat losses and gains of building envelopes. Thus, the thermal comfort will be greatly maintained in both summer and winter without using energy, and only a minimal amount of energy input is required during the peak temperature (Omran and Marsono, 2016). Ecological Design works with the environment to eliminate unnecessary heat or cold and to make the most advantage of the sun and breeze to avoid or eliminate mechanical heating and cooling usage (Council, 2011). This is also supported by Çerçi (2014), who stated that, Passive building design has notable features in which, it does not require external energy, so there are no operating costs, nor it polluting environment. These features improve the visual appearance of a building and also maintain its fabrics.

The ecological building standards, which defines efficient energy buildings performance with heating not rely on fossil fuel, was initially developed in central European countries, and lately it has been revised to adapt its criteria to different climate contexts. It is characterized by design criteria that focus on the energy efficiency of integrated building systems, the pursuit of energy savings, and minimization of energy-driven active devices and accessories (Boeri and Longo, 2010). As a result, the climate environment plays a crucial role in building construction strategies, it is the primary benchmark for determining the design criteria for energy efficient buildings. Control of external conditions through the building envelope is crucial for energy savings. Therefore, it is necessary to adopt various standards related to the climate zone.

As stated by Tabesh and Begum (2015), Passive building design may result in higher requirements than traditional architectural design, but these systems can reduce the cost of auxiliary heating and cooling in a building without compromising occupants comfort. Therefore, passive elements is considered to be best for designing a new energy efficient buildings. Presently, several climate-balanced and sustainable building has been constructed. Furthermore, the number of Passive houses is rapidly

increasing in different countries such as Austria, Germany and Switzerland. In January 2004, in Germany alone, more than 4000 buildings have been constructed considering passive house standards (Antonova, 2010). Similar initiatives are necessary for Turkey's cities ongoing urbanization like Gaziantep. Thus, adopting passive strategies in buildings can be a promising measure in improving building energy performance.

Ecological building design includes building designs containing building materials which respect environment, reduce energy consumption to minimum, use local resources, create healthy indoors, use solar energy, and natural lighting. As buildings have adverse effects on environment during their lifetimes, since construction till demolition (Gültekin and Ersöz, 2013). Thus, to reduce these effects, designers should adopt ecological building design criteria as it aims at reducing energy, maintenance and repair costs, illnesses related to buildings, reduce waste and contamination, and to increase the efficiency of building materials, building comfort and the resistance and flexibility of the building and its components (Erten, 2012).

Generally, passive design means taking advantage of natural energy flow to keep thermal comforts inside the building. Moreover, it also means selecting a proper building orientation and materials. The building should be oriented appropriately, and building envelope materials should selected properly to avoid or decrease heat gain. Providing shading is also necessary, as it reduces solar radiation (Altan et al., 2016). Moreover, passive design strategies should lead to the best use of natural energy strategies (passive heating and cooling) and renewable energy devices (Çerçi, 2014). Gültekin and Alparslan (2011) classified the ecological design criteria into four categories, these are, energy conservation, material conservation, water conservation and design of livable environment, and they identified different strategies and methods under these design categories.

Drawing from several studies on ecological design criteria, we will examine the strategies and methods related to building design which can be simulated through integrated BIM use. Thus, two design criteria namely energy conservation and material conservation will be considered, and strategies related to those criteria will be adopted for the purpose of examining building design and developing rules reflecting the best decisions related building design and ensuring compliance to ecological design

measures for buildings in Turkey. Table 7.1 presents the strategies and methods that will be examined for ecological building design.

**Table 7.1.** Strategies and methods related to ecological building design

<b>Building energy performance facets</b>	<b>Design Strategies</b>	<b>Design Criteria</b>
<b>Energy conservation (EC)</b>	Considering physical environmental conditions	Effective direction of the building (EC 1)
	Design of energy-efficient building form	Design of simple geometric building form (EC 2)
	Selection of energy efficient landscape design	Green roof application (EC 3)
	The application of renewable energy	Proper use of photovoltaic (PV) (EC 4)
<b>Material conservation (MC)</b>	Appropriate selection of energy efficient building materials	Proper and efficient insulation materials (MC 1)
		High performance glass (MC 2)
		Efficient wall material (MC 3)
		Effective shading (MC 4)

As shown in table 7.1, the strategies and methods related to energy conservation and materials conservation are presented. Accordingly, all the design parameters related to those strategies will be examined and analyzed. Consequently, a couple of design rules will be developed. This will be done through conducting a real ecological building (passive house) case study located in Gaziantep-Turkey by using BIM.

## 7.2. Ecological Building Case Study

The building has been constructed in Gaziantep-Turkey. It was built on the premises of Ataturk Culture Park by mean of a joint undertaking by Gaziantep University and the Gaziantep Metropolitan Municipality. The building is one story building, consist of a 60-seat conference hall, a computer room situated in the building's entry can be used by visitors to gather information as a study room, and bathrooms.

As a first step, a 3D building geometry is created by using Revit architecture (see figure 7.1), and then transferred to design builder software through gbXML (see figure 7.2), to carry out the simulation analysis.



**Figure 7.1.** 3D geometry of ecological building

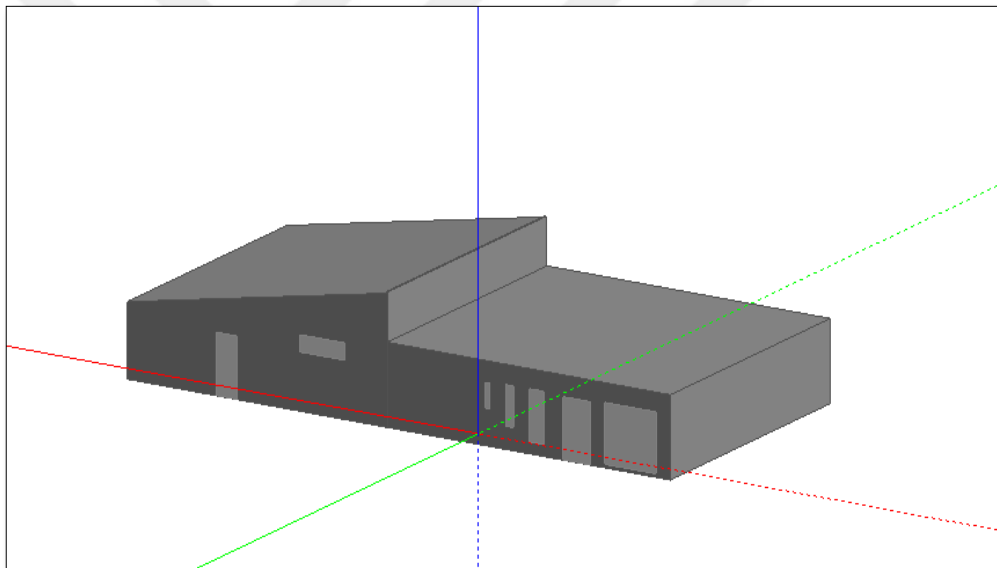

**Figure 7.2.** Building model in design builder

Once the building is transferred to Design building, then all the information related to physical properties of the building is loaded in design builder software. This is to define the actual properties of ecological building model and prepare it for energy performance analysis. The information needed can be divided into two categories: building location and orientation, and physical properties of the building construction elements including: external wall, internal wall, floors, roofs, glazing, lighting and HVAC system used in the building. Once the building properties is loaded, then the actual energy performance of the building can be calculated.



### 7.2.1. Building location and properties

The location chosen was Gaziantep-Turkey. The longitude and latitude are 37.37° E and 37.08° N respectively, the altitude is 832 meters above sea level, the actual site orientation is at 345°.

### 7.2.2. The properties of building materials

The physical characteristic of the building's components and materials used the actual building model are shown in table 7.2.

**Table 7.2.** The physical properties of the actual building construction materials

<b>Building components</b>	<b>Materials layers</b>	<b>Thickness (m)</b>	<b>U-Value (w/m<sup>2</sup>. k)</b>
External wall	Cement plaster +paint	0.01	0.112
	Cement board	0.014	
	Glass fiber wool	0.30	
	Reinforced wall	0.30	
Internal wall	Gypsum plaster board	0.025	2.00
	Reinforce concrete	0.1	
	Gypsum plaster board	0.025	
Floor	Basalt flooring	0.03	0.086
	Cement mortar	0.02	
	Glass fibre wool	0.03	
	Reinforced concrete	0.30	
	Cement mortar board	0.05	
	Felt separator layer	0.002	
	PVC (water proofing)	0.03	
	Felt separator layer	0.002	
	XPS extruded polystyrene	0.30	
	Protective cement	0.05	
	Gravel	0.30	
Flat roof	Green roof	0.2	0.066
	Roofing felt	0.002	
	PVC (water proofing)	0.03	
	Roofing felt	0.002	
	Cement plaster mortar / plasterboard	0.015	
	XPS extruded polystyrene	0.3	
	Glass wool	0.2	
Reinforced concrete	0.2		

Regarding the type of the window and glazing used for the building, the characteristics of the window materials are presented in table 7.3.

**Table 7.3.** The physical properties of the building exterior windows

Glaze type	Thickness (mm)	Frame	Total solar transmission (SHGC)	U- value (W/m <sup>2</sup> . k)
Triple glazing- low e glass	4 mm	Aluminum	0.395	0.852

As shown in table 7.3, a triple glazed façade is used which consists of three layers of 4mm low e glass with 16 mm argon gap, the frame type is aluminum.

### 7.2.3. The actual building energy consumption

Once the properties of the building elements are loaded in the building model, then the actual building energy performance is calculated. Figure 7.3 shows, the calculated amount of the energy consumed, and CO<sub>2</sub> emitted by the actual building design.

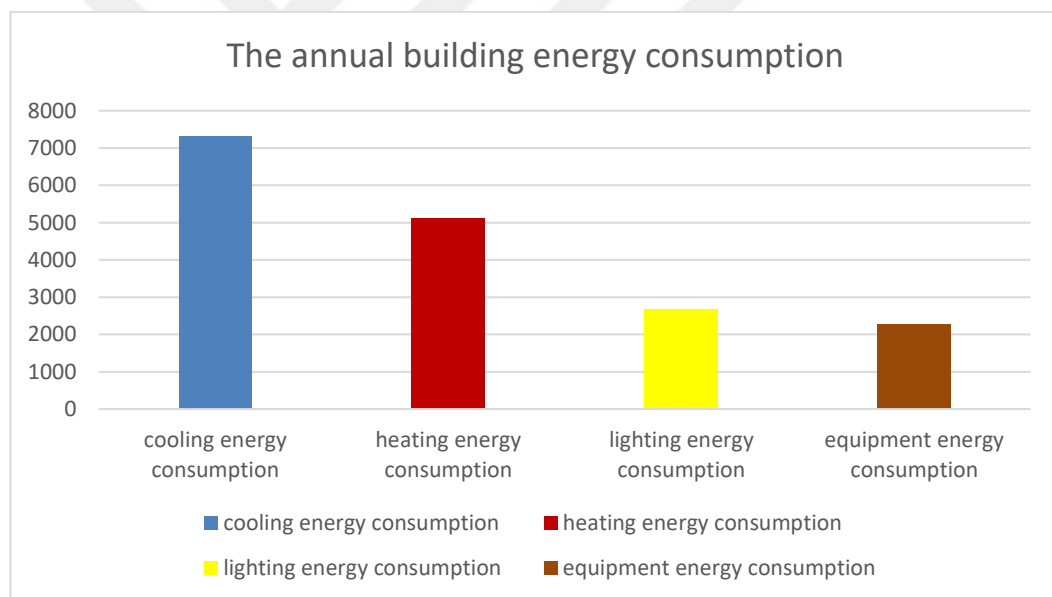

**Figure 7.3.** Annual building energy consumption

As shown in figure 7.3, the calculated amount of cooling and heating energy consumption are equal to 7302.95 (KWh), 5111.90 (KWh) respectively, while the energy consumed for lighting and equipment are equal to 2670.85 (KWh) and 2262.52 (KWh) respectively, making annual energy consumption equal to 17348.22 (KWh). The annual CO<sub>2</sub> emitted by the building is equal to 8738.94 Kg.

According to Ryan and Sanquist (2012), the results of the simulation carried out by energy analysis software should be checked and validated, this can be done by

comparing the obtained results with the calculated data of the actual design model. Therefore, the actual building energy consumption was compared with the simulation results obtained from design builder tool.

The actual energy consumption of the building is equal to 16178 KWh while the results obtained from design builder software suggest a total energy use equal to 17348.22 KWh. The real value of 16178 KWh is about %9 less than the computed value in Design builder software. The reason behind this difference is greatly due to fact that the actual energy consumption value is for 2017. In addition, there are some materials used in the building were locally manufactured which are not exit in the software. Hence, the researcher used some other similar materials with different physical properties.

Since the main aim is to achieve efficient building design in term of energy performance. Therefore, based on the strategies and methods presented in table 9.1, the researcher will examine the impact of various parameters related to those strategies and methods on the building energy performance by using BIM. Thus, developing rules reflecting the best design decisions to be used for buildings in Gaziantep-Turkey.

#### **7.2.4. Energy conservation criteria**

Energy consumption begins at the production phase and continues during the phase of construction and use of the building. As shown in table 9.1, energy conservation can be ensured by implementing the following methods: effective direction of building, the use of simple geometric design form, green roof application, and finally proper use of photovoltaic (PV). These methods will be studied in the following sections.

##### **7.2.4.1. Effective direction of the building**

As a part of building design, the orientation of building should be considered. In term of orientation, the building design should enable the received solar radiation from south for free energy, getting heat to the inside of the building, which results in decreasing the amount energy and heating energy during colder periods. This was deeply studied in chapter 6 for ARBIM building case study, where different directions were analyzed and simulated, and their impacts on the heat gains and losses of the vertical surface of the building were also calculated. The results showed that, when locating the building in the east-west axis, where the long length walls are facing the

south- north direction and the bigger glaze area stored on the walls facing south direction, the building will perform the best in term of energy performance, this was achieved by placing the building at 0-degree direction in Design builder software.

The actual building orientation is at 345° degree, which means that, the building orientation is at 15° degrees towards east from the south orientation. Thus, to check whether the calculated optimum orientation is the best decision to make, both actual and the optimum direction were simulated in Design builder software. The results are presented in table 7.4.

**Table 7.4.** The impact of different building orientations on energy performance

<b>Orientation</b>	<b>Cooling energy consumption (KWh)</b>	<b>Heating energy consumption (KWh)</b>	<b>Annual energy consumption (KWh)</b>	<b>Annual CO<sub>2</sub> emission (Kg)</b>
Actual building orientation (345°)	7302.95	5111.90	12414.85	8738.94
Optimum orientation south	7054.39	5030.95	12085.34	8630.00
East orientation	9431.44	6538.18	15969.62	10335.30
North orientation	6093.29	6780.36	12873.65	10131.55
West orientation	9493.30	6492.62	15985.92	10321.16

As shown in table 7.4, when the building at 0-degree direction which represent the south direction, less energy will be consumed when compared to the actual building orientation, making an annual energy saving equal to 329.51 (KWh), and annual reduction in CO<sub>2</sub> emission equal to 108.94 (Kg). Therefore, in order to choose a proper and effective orientation, building should be placed at south orientation, where the long length walls facing the south-north direction. In addition, bigger glaze area should be stored at the walls facing south direction.

#### **7.2.4.2. Design of simple geometric form**

Based on the literature, building architectural is also a valuable tool in achieving energy efficient buildings. Thus, Compact building form performs better than complex

building, this is due less heat loss can be achieved through the envelope materials exposed to environment.

A rectangular building shape has been adopted in ecological building design. However According to Pacheco et al. (2012), there are different parameters related building shape, which may impact the cooling and heating energy consumption of the building, among these parameters is the shape factor, which is the proportion of building length to its width. The importance of this parameter has been always considered alongside building orientation.

The shape factor of ecological building is equal to 2.1, as the length is equal to (28.25 m) and width is equal to (13.61 m). To determine the best shape factor for the building, a simple building model was created by using design builder. This is to avoid errors happened when exporting building model from Revit to design builder, and to save time. To do that, a 100 m<sup>2</sup> plan was created and analyzed by using design builder, different shape factor is simulated.

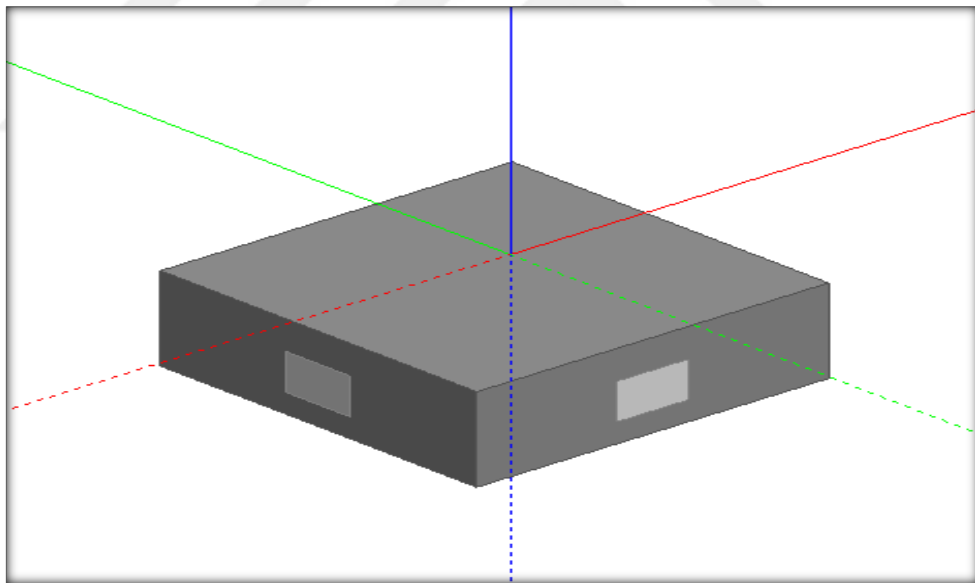

**Figure 7.4.** 100 m<sup>2</sup> square building model

The first case of 100 m<sup>2</sup> with equal length at all the four side was modeled (see figure 7.4). Then, after identifying the properties of the model, the energy analyses were carried out to calculate the total energy use of the building. for the second case, by considering a fixed building area (100 m<sup>2</sup>), the length of the north south walls was increased by 10%, meanwhile the length of east-west walls was decreased by 10%. Same process was done for 9 more cases (table 7.5).

This is to find the less energy load by comparing the energy performance of the simulated cases, thus finding the best proportion of walls length to width (shape factor).

**Table 7.5.** The impact of building shape on building energy performance

The length added to south- north direction	X, Walls in north-south. (m)	Y, Walls in east-west. (m)	Shape factor X/Y	Cooling energy load (KWh)	Heating energy load (KWh)	Total energy load (KWh)
0	10.00	10.00	1.00	1901.94	927.78	2829.72
10%	11.00	9.091	1.21	1858.57	911.52	2770.09
20%	12.00	8.333	1.44	1794.93	917.29	2712.22
30%	13.00	7.692	1.69	1789.17	893.12	2682.29
40%	14.00	7.143	1.96	1788.80	865.59	2654.39
<b>45% (Actual)</b>	<b>14.5</b>	<b>6.896</b>	<b>2.102</b>	<b>1796.89</b>	<b>851.89</b>	<b>2648.78</b>
50%	15.00	6.667	2.25	1805.7	836.93	2642.63
60%	16.00	6.250	2.56	1833.01	801.37	2634.38
<b>70%</b>	<b>17.00</b>	<b>5.882</b>	<b>2.89</b>	<b>1820.62</b>	<b>795.68</b>	<b>2616.3</b>
80%	18.00	5.556	3.24	1857.55	766.01	2623.56
90%	19.00	5.263	3.61	1905.62	736.72	2642.34
100%	20.00	5.00	4.00	1952.46	706.53	2658.99

As shown in table 7.5, the minimum energy consumption is achieved when the shape factor is equal to 2.89, making an annual energy consumption of 2616.3 KWh. This means that, the wall lengths in north south direction have to be 2.89 times more than the wall length in east-west direction. The results also indicate that square building shape perform the worse in term of energy consumption. Therefore, in order to design an efficient building form, designers should do the following: rectangular building shape with shape factor equal to 2.89.

#### **7.2.4.3. Green roof application**

One of the methods for implementing energy efficient landscape, is the application of green roof or what it called eco-roofs. Green roofs are the key to provide the building with less energy use and CO<sub>2</sub> emission, in which the plants and soil will help the cooling process through water evaporation in summer, moisturizing the air and thus, cooling the building naturally. On the other hand, the soil layer will work as insulation

layer and thus reducing the heating energy use of building in the winter. The green roof used for the ecological building design and its layers are shown in figure 7.5.

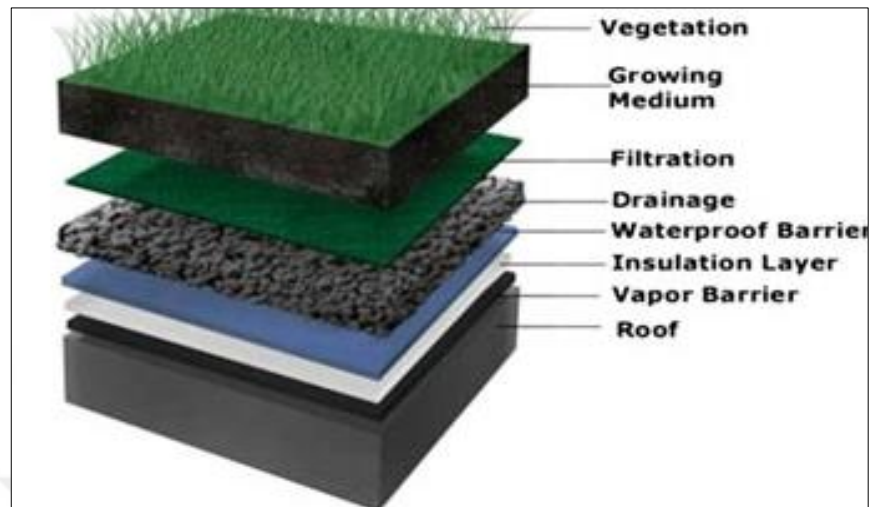

**Figure 7.5.** The layers of the green roof

As mentioned by (Vera et al., 2015), the parameters affecting the performance of green roofs are: the plants Height, and leaf area index (LAI). The (LAI) is the percentage of the surface of leaves to the transpiring parts of the plants and soil layer below. Figure 7.6 shows two types of plants with different leaf are index.



**Figure 7.6.** Sparse vegetation on the left, and large vegetation on the right

In this section, the impact of plants height and leaf area index (LAI) on the building energy performance will be studied. This will help to understand the effects of these parameters, thus increasing the benefits of green roofs based on proper selections of green roof system. Firstly, different plants height are simulated, and their impact on

building energy performance are also studied. Table 7.6 shows three types of plants Height and their impact on energy performance.

**Table 7.6.** The impact of plants height on building energy performance

<b>Plant height (LAI=1)</b>	<b>Cooling energy consumption (KWh)</b>	<b>Heating energy consumption (KWh)</b>	<b>Total energy consumption (KWh)</b>
0.1	7888.49	4997.0	12885.49
0.2	7859.56	5007.77	12867.33
0.3	7811.68	5026.76	12838.44

As shown in the table 7.6, when increasing the plants height, the cooling energy performance decreases and heating energy use increases. The reason behind that was explained by (e Silva, 2014), who said that, increasing the plant height leads to an increase of the wind velocity within the canopy, which will result in decreasing the aerodynamic resistance, and facilitating the transpiration cooling effect. Higher plants lead to higher energy consumption in the heating season and lower energy consumption in the cooling season. In general, it leads to lower the building energy consumption in total, since the decrease in cooling energy consumption is higher than the increase in heating energy consumption.

The second parameter which affect the performance of green roof on building energy performance is the leaf area index (LAI). Different types of (LAI) are studied, and their impact on the energy performance of the building are also investigated. Table 9.7 shows, three LAI (1, 2.5. and 3) and their impact on the building energy performance.

**Table 7.7.** The impact of LAI on building energy performance

<b>LAI (Height=0.3)</b>	<b>Cooling energy consumption (KWh)</b>	<b>Heating energy consumption (KWh)</b>	<b>Total energy consumption (KWh)</b>
1	7811.68	5026.76	12838.44
2.5	7302.95	5111.9	12414.85
3	7206.23	5169.41	12375.64

As shown in the table 7.7, when increasing (LAI), a great decrease in cooling energy use is recorded while the heating energy is increased. In general, with higher LAI, the total energy consumption decreases. According to (e Silva, 2014), increasing the LAI increases the shading on the roof, which in turn will reduce the solar heat gain, and the



transpiration of plants. As result, the cooling energy will be decreased. In other words, increasing the LAI, decreases the cooling energy consumption and increases the heating energy consumption.

Based on the literature in chapter 2, there are three types of green roof, these are: Extensive, Intensive, and Semi Intensive green roofs. Each one of them has different characteristics in term of plant height, and leaf area index (LAI) and soil thickness. Therefore, all the three systems will be simulated for finding the most effective green roof system to be implemented in the building design, knowing that, the actual green roof used for ecological building is semi intensive system. Table 7.8 shows the impacts of diverse types of roof systems with their impact on building energy performance.

**Table 7.8.** The impact of different roof system on building energy performance

<b>Roof type</b>	<b>Cooling energy consumption (KWh)</b>	<b>Heating energy consumption (KWh)</b>	<b>Total energy consumption (KWh)</b>
No green roof	7604.46	5296.89	12901.35
Extensive green roof (LAI=2, height =0.1m)	7460.32	5052.11	12512.34
<b>Semi intensive green roof (LAI=2.5, height=0.3m)</b>	<b>7302.95</b>	<b>5111.90</b>	<b>12414.85</b>
<b>Intensive green roof (LAI= 4, height= 0.8)</b>	<b>7159.34</b>	<b>5190.36</b>	<b>12349.7</b>

As presented in table 7.8, all types of green roofs system lead to reduce both cooling and heating energy consumption compared to conventional roof system. Moreover, the intensive roof system performs the best compared to extensive and semi intensive green roofs. This is mainly due to the plant height as well as LAI, which increase the shading and decrease the solar heat gain which in turn decreases the cooling energy load. Thus, in order to design a green roof, designers should consider the following: the use of intensive green roof with plant height of 0.8 and LAI of 4.

#### **7.2.4.4. Proper Use of photovoltaic (PV) panels**

One of the methods of renewable energy strategies, is the use of photovoltaic PV technology. This method was deeply studied in chapter 6, by exploring the design process steps needed to design PV modules by using design builder and studying the impact of performance parameters on the energy generation of PV modules. These

parameters are: PV orientation, PV tilt angle, and PV row spacing. The results showed that using PV with orientation facing south, tilt angle of (30°) degree, and row spacing not less than (1.5m), have the best performance in term of energy generation.

For the ecological building design, the decision was made to place the PV on the ground with orientation facing the south, tilt angle of (30°) degree, and the row spacing was more than (4m) because of the free space available for the panels. The decision totally confirmed the results obtained in chapter 6. Therefore, the best design decision related to PV technology should be as follows: the orientation should be facing south, PV tilt angle should be at (30°) degree, row spacing not less than (1.5m).

### **7.2.5. Material Conservation Criteria**

Materials conservation can be ensured in the building design through the application of different methods such as: choosing proper insulation materials, high performance windows, efficient wall materials, and effective shading use. These methods will be studied in following sections

#### **7.2.5.1. Preventing heat loss by choosing proper insulation materials**

The insulation of building envelopes makes a great contribution to building energy performance. Rather than its characteristics, other criteria which determines its efficiency such as the components to be installed, either wall or roof are in place.

In chapter 6, the impact of three types of wall insulation materials on building energy performance were studied. These materials are: Extruded Polystyrene (XPS), Expanded Polystyrene (EXP), and Rock Wool (RW). The results showed that, extruded polystyrene (XPS) performs the best compared to other two insulation materials. In ecological building, the insulation material used for wall was extruded polystyrene (XPS).

However, for the exterior wall, another insulation material was used, which is glass wool (GW). Therefore, by considering the glass wool insulation material, we will study the impact of adding the four types of insulation materials for both roof and wall on the building energy performance. This is to find the optimum insulation materials to be used for both roof and wall. Table 7.9 shows the impact of adding (XPS, EXP, RW, and GW) to the wall respectively on the building energy performance.

**Table 7.9.** The impact of wall insulation on building energy performance

<b>Insulation type</b>	<b>U- value (W/m2. k)</b>	<b>Cooling energy consumption (KWh)</b>	<b>Heating energy consumption (KWh)</b>	<b>Total energy consumption (KWh)</b>
Extruded polystyrene (XPS)	0.096	7278.93	5027.70	12306.63
Expanded polystyrene (EXP)	0.127	7319.62	5207.64	12527.26
Rock wool (RW)	0.148	7352.46	5306.22	12658.68
Glass wool (GW)	0.112	7302.95	5111.9	12414.85

As shown in the table 7.9, the results confirm that Extruded Polystyrene (XPS) is the best type to be used for insulation, while the Rock Wool (RW) has the less impact among the others. Therefore, the rank of the materials from best to less effectiveness are as follows: Extruded Polystyrene (XPS), Glass Wool (GW), Expanded Polystyrene (EXP), and finally Rock Wool (RW). Similarly, this process is implemented for the roof (see table 7.10).

**Table 7.10.** The impact of roof insulation on building energy performance

<b>Roof insulation type</b>	<b>U- value (W/m2. k)</b>	<b>Cooling energy consumption (KWh)</b>	<b>Heating energy consumption (KWh)</b>	<b>Total energy consumption (KWh)</b>
Extruded polystyrene (XPS)	0.087	7302.95	5111.9	12414.85
Expanded polystyrene (EXP)	0.112	7331.38	5269.82	12601.20
Rock wool (RW)	0.128	7333.22	5394.45	12727.67
Glass wool (GW)	0.1	7332.98	5187.78	12520.76

The results showed that, extruded polystyrene is the most energy efficient material making less energy consumption, while rock wool (RW) has less impact among the other materials. Thus, the rank of the material from best to less impact are as follow: Extruded Polystyrene (XPS), Glass Wool (GW), Expanded Polystyrene (EXP), and

Rock Wool (RW). As a rule, the design decision related to the type of insulation for both (wall and roof) is extruded polystyrene (XPS).

### 7.2.5.2. High performance window

Windows are an important elements in the building as it plays a great role in eliminating the overall building energy consumption. As mentioned by Karasu (2010), the parameters impacts window performance are as follow: the glazing layers, thickness and the gas infill type.

In chapter 6, examining the impact of glazing on building energy performance covered only double glaze windows considering different glaze types and thicknesses. While, the glazing system used in the ecological building case study is triple 4mm low e glaze-16mm argon gap. Therefore, in this section, we will expand the study to cover all glazing systems including single, double, and triple glazing with different glaze types and thickness, also the infill gas type and its thickness will be considered and simulated, this is find the most efficient window system to be considered in the building design in Turkey. Firstly, 3 types of window system including, triple, double, and single glazing with two different thickness of (4-6) mm are analyzed and simulated. Table 7.11 shows the impact of different window system on building energy performance.

**Table 7.11.** The impact of window system type on building energy performance

Glazing type	U-value (W/m <sup>2</sup> . k)	SHGC	Cooling energy load (KWh)	Heating energy load (KWh)	Total energy load (KWh)
Triple 4mm low e- 16 mm argon	0.852	0.395	7302.95	5111.90	12414.85
Triple 6mm low e- 16 mm argon	0.849	0.383	7172.66	5218.44	12391.1
Double 4mm low e- 16 mm argon	1.896	0.469	8647.05	4774.71	13421.76
Double 6mm low e- 16 mm argon	1.881	0.458	8493.34	4855.65	13348.99
Single low e 6 mm	3.162	0.468	8532.65	5286.21	13818.86
Single low e 4mm	3.184	0.468	8506.16	5276.92	13783.08

As shown in the table 7.11, the use of triple glazing system has the best performance in term of energy performance compared to the double and single glazing system. Also, the thickness plays a key role in decreasing the amount of energy used by the building, in which 6 mm glaze lead to less energy consumption when compared to 4mm glaze window.

Secondly, the type of gas infill gap was simulated. Table 7.12 shows the impact of the gas type on building energy performance.

**Table 7.12.** The impact of window gas gap types on building energy performance

Gas infill type	U- value (W/m <sup>2</sup> . k)	SGHC	Cooling energy load (KWh)	Heating energy load (KWh)	Total energy load (KWh)
16 mm argon	0.852	0.395	7302.95	5111.90	12414.85
16 mm air	1.045	0.402	7383.19	5194.94	12578.13
16 mm xenon	0.718	0.390	7293.09	5072.38	12365.47

As shown in table 7.12, it is clear that xenon gas infill as it has which has well thermal properties leads to efficient energy performance compared to argon and air gas infill. The rank of the gas types from best to less impact on energy performance are: xenon, argon, and finally air gas infill. Finally, the impact of gas infill thicknesses on building energy performance were simulated. Table 7.13 shows the impact of different gas thickness on building energy consumption.

**Table 7.13.** The impact of window gap thickness on building energy performance

Gap thickness	U- value (W/m <sup>2</sup> . k)	SGHC	Cooling energy consumption (KWh)	Heating energy consumption (KWh)	Annual energy consumption (KWh)
16 mm	0.852	0.395	7302.95	5111.90	12414.85
13 mm	0.935	0.396	7310.15	5159.80	12469.95
10 mm	1.1	0.401	7353.44	5219.95	12573.39
6mm	1.490	0.412	7420.91	5385.23	12806.14
4mm	1.867	0.420	7453.65	5560.71	13014.36

As shown in table 7.13, the thickness of gas infill has an impact on the building energy performance, as the layer thickness decreases, the energy consumed by the building

increases. This is mainly due to increase in the U-value and SGHC, which lead to an increase in cooling and heating energy consumption. The rank of the impact of gap thickness from best to less are as follows: 16 mm, 13, mm, 10mm, 6mm, and finally 4mm.

Based on the analysis carried out for the window system types, including the window types and thicknesses, gas infill types and thickness. The best window system to be used in building design is triple 6mm low e glazing, 16mm xenon gas infill gap.

### 7.2.5.3. Appropriate wall materials selection

The ecological building exterior walls have been designed with the reinforced concrete by using ecological building material such as gas concrete which can be obtained from facilities located in Gaziantep and the area surrounding it. Gas concrete is preferred to be used for walls as it preserves energy by providing heat insulation (Gültekin and Ersöz, 2013).

However, this construction method is not widely applicable especially for large and multistory because of its excessive cost. Therefore, we will provide other types of wall material which is locally used and will simulate their impacts on building energy consumption together with the type used for the actual building design. Table 7.14 shows the impact of different wall construction system on building energy performance.

**Table 7.14.** The impact of different wall materials on building energy performance

Wall type	U- value (W/m2. k)	Cooling energy consumption (KWh)	Heating energy consumption (KWh)	Total energy consumption (KWh)
Reinforced concrete	0.112	7386.10	5264.98	12651.08
Auto claved concrete block	0.094	7416.82	5016.71	12433.53
Brick aerated	0.105	7455.99	5199.62	12655.61
Concrete block	0.108	7431.07	5217.46	12648.53

As shown in table 7.14, the AAC block is the most efficient material to be used in wall construction in which lower energy consumption is achieved compared to the other

wall material. This is mainly due its lower U-value, which ensures lower heat loss through the wall and consequently lower energy consumption is consumed. Reinforced concrete wall is also efficient as the gas concrete is used which works as a heat insulator. In general, to ensure efficient building design, the use of AAC block for wall construction is recommended.

#### 7.2.5.4. Effective window shading design

Appropriate collection of shading device are vital in achieving efficient energy and building comfort conditions. Shading element changes the amount of reflected and diffused solar radiation striking the opening of the building. In this section, simulation is run for two types of shading which are, window shading, and local shading separately.

For Window shading, three types of internal window shading are studied and simulated. These types are, slatted blind with high reflectivity, diffusing blind- shade roll, and drapes close weave light. The choices made to control the interior shading during the year, are as follows:

- In summer: shade devices are used at night time and also during the day in case the solar radiation is more than the set point (120 w/m<sup>2</sup>).
- In winter: shade device are used at the night time when the heating system is on and off during the day.

**Table 7.15.** The impact of interior window shading on building energy performance

Window shading type	Cooling energy consumption (KWh)	Heating energy consumption (KWh)	Total energy consumption (KWh)
No shading	7302.95	5111.90	12414.85
Slatted blind-high reflectivity	7036.14	5110.12	12146.26
Diffusing blind – shade roll	7338.85	5110.84	12449.69
Drapes close weave	7087.99	5110.79	12197.78

As shown in table 7.15, it's obvious the slatted blind with high reflectivity is the best choice to be made for internal shading design which reduces the cooling load by 266.81

KWh compared to non-shaded window. On the other hand, the use of diffusing blind shade roll type is not recommended as it increases the cooling energy use.

For local shading, the type of shading systems simulated are, overhang of different projection (0.4, 0.5, 0.75) m, Fin shading with different projection (0.4, 0.5, 0.75) m, and overhand and fin with projection of (0.5) m. each one of them are analyzed separately, and their impacts on the cooling and total energy consumption are calculated. Table 7.16 show the types of local shading simulated and their impact on building energy performance.

**Table 7.16.** The impact of exterior window shading on building energy performance

Shading type	Cooling energy consumption (KWh)	Heating energy consumption (KWh)	Total energy consumption (KWh)
No shading	7302.95	5111.90	12414.85
Overhang (0.4 m)	6617.03	5498.31	12115.34
Overhang (0.5 m)	6432.66	5604.8	12038.46
Overhang (0.75 m)	6174.03	5853.24	12027.27
Fin (0.4 m)	6989.77	5322.81	12312.58
Fin (0.5 m)	6921.22	5379.34	12300.56
Fin (0.75m)	6839.87	5494.49	12334.36
Overhang (0.5 m + fin 0.5)	6106.27	5884.07	11990.34

As shown in table 7.16, three shading system types are simulated, and these are overhang, fin, and both overhang and fin. The simulation results showed that, the combination of overhang and fin with projection of (0.5m) led to less cooling consumption and thereby total energy consumption compared to other types of shading. Consequently, it represents the best design decision to be made for buildings in Gaziantep-Turkey. Finally, the combination of both internal and external shading is simulated and their impact on building energy performance are calculated. Table 7.17 shows the impact of the combination of both internal and external shading by considering the best choice of both.



**Table 7.17.** The impact of interior and exterior window shading on building energy performance

Shading type	Cooling energy consumption (KWh)	Heating energy consumption (KWh)	Total energy consumption (KWh)
No shading	7302.95	5111.90	12414.85
Slatted blind + (overhang and fin of 0.5 projection)	5853.74	6331.24	12184.98

As shown in table 7.17, it's obvious that the combination of both internal and local shading impacts the building energy performance. Applying both internal and external shading let to decrease the total energy consumed by the building, making an annual energy saving of 229.87 KWh.

### 7.3. Building Design Rules Reflecting Local Values

After conducting a comprehensive study about the building design strategies and methods and examining different design parameters by analyzing and simulating their impacts on building energy performance, a couple of rules are formulated. These rules represent the best design decision to be made for buildings in Gaziantep -Turkey. The design rules are presented in table 7.18.

**Table 7.18.** Building design rules reflecting local values

<b>Building energy performance facets</b>	<b>Design Strategies</b>	<b>Design Criteria</b>	<b>Design Rules and ontology</b>
<b>Energy conservation (EC)</b>	Considering physical environmental conditions	Effective direction of the building (EC 1)	Long length walls should be facing north-south orientation (EC 1.1)
			Bigger glaze area should be facing south orientation (EC 1.2)
	Design of energy-efficient building forms	Using simple geometric design (EC 2)	Rectangular shape (EC 2.1)
			Shape factor = 2.89 (EC 2.2)
	Selection of energy efficient landscape design	Green roof application (EC 3)	Intensive green roof, (LAI= 4, plant height= 0.8) (EC 3.1)
	The application of renewable energy	Proper use of photovoltaic (PV) (EC 4)	Orientation- south (EC 4.1)
			Tilt angle= 30 (EC 4.2)
Raw spacing $\geq 2$ (EC 4.3)			
<b>Material conservation (MC)</b>	Appropriate selection of ecological and efficient energy building materials	Preventing heat loss by choosing proper insulation materials (MC1)	Extruded polystyrene XPS for roof (MC 1.1)
			Extruded polystyrene XPS for wall (MC 1.2)
		High performance window(MC2)	Window system-triple window (MC 2.1)
			Glazing type- low e coating (MC 2.2)
			Glaze thickness- 6mm (MC 2.3)
			Gap infill type- xenon, and gap thickness-16 mm (MC 2.4)
			Window gap thickness-16 mm (MC 2.5)
		Efficient wall material (MC 3)	Autoclaved aerated concrete (AAC) (MC 3.1)
		Effective shading (MC 4)	Window shading- slatted blind (MC 4.1)
			Local shading- overhang and fin of (0.5m) projection (MC 4.2)

Following these rules, efficient and sustainable design can be achieved in the initial stages. Thus, less energy for both heating and cooling will be consumed which in turn will lead to less CO<sub>2</sub> emission.

#### **7.4. Building Design Evaluation (Local Energy Performance Assessment Scheme)**

This section represents the fourth and last component of the proposed BIM-framework. After identifying the strategies and methods of passive building design and developing rules that represent efficient building design in term of energy performance. In this section an energy performance assessment and evaluation scheme will be developed, in order to measure the building design success level in term of energy performance. As mentioned in chapter 5, a strong building performance assessment scheme has a great role in evaluating building energy performance, typically for these countries which still do not have their own scheme for building energy assessment such as Turkey. Thus, it is necessary to understand and study the various available schemes and their assessments techniques, scope, performance criteria and credit scale.

##### **7.4.1. Green building certificate schemes**

Building green certifications are the core and most practical part of green buildings practices in the AEC industry. presently, there are a well-established green buildings certifications in various countries around the world that are being adopted to evaluate various building aspects such as site selection, energy, water, material consumption, waste production and pollution. However, there are an agreements that global certifications of green buildings is not possible due regional differences in environment conditions, supply of energy, raw material, water, availability of green materials, and economic conditions (Ilter and Ilter, 2011). Therefore, a local energy assessment scheme is highly needed that represent the local environment condition and values. As mentioned in chapter 6, the most widely used and representative schemes are Leadership in Energy and Environmental Design (LEED), Building Research Establishment Environmental Assessment Method (BREEAM) and Green Star scheme. However, they are greatly varying in the assessment method, criteria and scope with regards to the building performance rating. In the following sections, the key characteristics of energy assessment method of each one of them will be reviewed.

#### **7.4.1.1. LEED scheme**

LEED is the most broadly used building environmental assessment scheme. The recorded building projects with LEED have covered around 24 different countries (Lee and Burnett, 2008). It is based on a set of prerequisites and credits. Each credit refers to one of the following aspects which are, sustainable sites, water efficiency, energy and atmosphere, materials and resources, indoor environmental quality, and innovation & design process. One point is given to each credit when the requirement is met except for the energy performance credit and the renewable energy credit in which several points is awarded to each credit depending on by how much performance improvement is achieved. This counts towards the total scoring system. With LEED, there are up to 69 points that can be achieved. Accordingly, there are four levels to qualify the buildings, which are Certified (26-32 points), Silver (33-38 points), Gold (39-51 points) and Platinum (52-69 points).

#### **7.4.1.2. BREERAM scheme**

BREEAM is the most widely used building environmental rating scheme in the U.K. even though it is a voluntary standard, the energy performance assessment adopts the U.K. Building Regulation as a benchmark to rate the level of performance enhancement. Alike to the credit rating system in LEED, BREEAM identifies categories of credits, each credit refers to one of the following, these are, management, health and wellbeing, energy, transport, water, materials, waste, land use, ecology and pollution. With BREEAM, there are up to 102 credits available. The total score percentage of an assessed building is calculated based on the credits available, number of credits achieved for each category and a weighting factor. Accordingly, the overall performance of the building can be divided into six levels these are, Unclassified (<30%), Pass (30%), Good (45%), Very Good (55%), Excellent (70%) and Outstanding (85%). For each category, there are a minimum number of credits that must be achieved.

#### **7.4.1.3. Green star scheme**

Green Star is the most widely used environmental rating system in Australia. It was developed to accommodate the need of buildings in hot climates in which cooling systems and solar shading are of major importance (GBCA). There are up to 142 points

that can be achieved. The credits are organized in the following aspect of the building and process: management, indoor environmental quality, energy, transport, water, materials, land use & ecology, emissions, and innovation. Accordingly, the building certification is expressed as several stars: 1-3 Stars (10-44 points, not eligible for formal certification), 4 Stars (45-59 points, Best Practice), 5 Stars (60-74 points, Australian Excellence) and 6 Stars ( $\geq 75$  points, World Leadership).

#### 7.4.2. A local energy performance assessment scheme

In this section, a local energy and evaluation scheme will be developed. This is to determine the success of the building design in following the developed rules in the previous section. Similar to LEED and BREEAM, the local energy assessment scheme is based on the goal of scoring method. This can be done by determining and evaluating the building design with regards to the developed rules in term of energy conservation (EC) and material conservation (MC) design criteria (see table 7.18).

Each one of these criteria have various strategies and methods, thereby, the developed rules which reflects the most energy efficient design. The scoring method will undertake these rules as an evaluation measure to the building design. Thus, based on the simulation results of the design parameters and alternatives, four scale scoring levels will be adopted which identifies the level of implementation success of these rules. Three points will be given for successful implementation of each rule, two points will be given for average implementation success, one point for unsuccessful or poor implementation and zero point for non-implementation of rules. Table 7.19 shows the evaluation and scoring scale legend and its levels of scoring.

**Table 7.19.** The evaluation scoring scale legend

Points (*)	Grades for the Implementation of Design Rules
0	Not implemented
1	un successful implementation
2	Average successful implementation
3	Successful implementation

For evaluating and assessing the actual building design, the created scoring scale will be used to grade each design parameters used in the building. This is done by comparing the design decision made in the actual building with the rules-based design and alternatives obtained from the simulation analysis for each design parameter.

Accordingly, a number of points will be given to each design rule, then the success level of the building design is determined in terms of percentage. Finally, based on the total point achieved from the evaluation, the building design then is classified from good to outstanding in term of energy efficiency. Table 7.20 shows, the local energy assessment scheme created, and the points given to the ecological building design criteria and methods.

**Table 7.20.** The local energy assessment scheme

<b>Local Energy Performance Assessment Scheme</b>							
<b>Energy conservation (EC)</b>	<b>Rules based building design</b>		<b>Points (*)</b>	<b>Material conservation (MC)</b>	<b>Rules based building design</b>		<b>Points (*)</b>
	Orientation EC1	EC 1.1	*		Insulation (MC1)	MC 1.1	*
		EC 1.2	*			MC 1.2	*
	Building form (EC2)	EC 2.1	*		External window (MC2)	MC 2.1	*
		EC 2.2	*			MC 2.2	*
	Green roof (EC3)	EC 3.1	*			MC 2.3	*
		EC 4.1	*			MC 2.4	*
	PV technology (EC4)		EC 4.2			*	MC 2.5
		EC 4.3	*		External window (MC3)	MC 3.1	*
							Window shading (MC4)
			MC 4.2	*			
<b>Total point achieved</b>			**	<b>Total point achieved</b>		**	
<b>Section points</b>			24	<b>Section points</b>		30	
<b>Success level %</b>			**	<b>Success level %</b>		**	
<b>Total success = ** %</b>							

As shown in table 7.20, a local energy assessment scheme is established. This assessment scheme is divided into two sections, each section encapsulates important and effective methods that should be considered in the building design. There are 3 points available for each design methods. Accordingly, the total points that could be achieved in both energy conservation section and material conservation section are equal to 24 and 30 points respectively. Thus, the total points available in the created assessment scheme are equal to 54 points. By using the evaluation legend (see table 9.19), it is possible to evaluate the actual energy performance and calculate the number of points achieved for any building design. Then by dividing the points achieved for

the actual design by the total points available in the local scheme, the total success in implementing or following the rules-based design can be calculated in percentage. Similar to the other green building certificate such as LEED and BREEAM, there will be five levels to qualify the building in term of energy efficiency, which are pass (50%-59%), good (60%-69%), very good (70%-79), excellent (80%-89%), outstanding (90%-100%).

Having the energy performance assessment scheme established, every building design can be evaluated. For this reason, we evaluated the ecological building design case study by using the created energy assessment scheme (see table 7.21).

**Table 7.21.** Ecological building design evaluation

<b>Local Energy Performance Assessment Scheme</b>							
<b>Energy conservation (EC)</b>	<b>Rules based building design</b>		<b>Points (*)</b>	<b>Material conservation (MC)</b>	<b>Rules based building design</b>		<b>Points (*)</b>
	Orientation EC1	EC 1.1	2			Insulation (MC1)	MC 1.1
Building form (EC2)	EC 1.2	2		External window (MC2)	MC 1.2	2	
	EC 2.1	3			MC 2.1	3	
Green roof (EC3)	EC 2.2	2			MC 2.2	3	
	EC 3.1	2			MC 2.3	2	
PV technology (EC4)	EC 4.1	3			MC 2.4	2	
	EC 4.2	3		MC 2.5	3		
	EC 4.3	3		External wall (MC3)	MC 3.1	2	
<b>Total point achieved</b>			20	<b>Total point achieved</b>			23
	<b>Section points</b>		24		<b>Section points</b>		30
<b>Success level %</b>		83		<b>Success level %</b>		77	
<b>Total success = 80%</b>							

This is to determine the success level of the building design in implementing the developed rules-based design. This was done through a study of the design decisions implemented for the actual building design by comparing them with the simulation results for each design parameters in the previous section. The findings are interpreted as follows:

For energy conservation criteria, the methods are effective direction of the building (EC1), use simple geometric design (EC2), green roof application (EC3), and proper

use of PV technology (EC4). In line to these methods, the rules EC 2.1, EC 4.1, EC 4.2, and EC 4.3 were implemented successfully, and then 3 points are awarded for each one. EC 1.1, EC 1.2, EC 2.2 were implemented with average success, accordingly 2 points are given to each one. EC 1.1 and EC 1.2 refers to the building orientation and it should be at south direction where long length wall are facing north-south and bigger glaze area should be at south direction. However, the orientation of ecological building is at 345 degrees. According to the simulation results this also can be effective when compared to other directions. Therefore, two points are given to both. EC 2.2 refers to shape factor, the shape factor of ecological building is 2.1, while the simulation results confirmed that shape factor of 2.89 is the most efficient to be used in building design, therefore 2 points are given to this design parameters. EC 3.1 refers to green roof application, the type used for the building is semi intensive green roof, while the simulation results proves that, intensive roof system is the type should be used as it's the most efficient one. Therefore 2 points are also given to this method.

For material conservation criteria, the methods used are choosing efficient insulation material (MC1), high performance window (MC2), efficient wall construction materials (MC3), and effective shading (MC4).

In line to these methods, MC 1.1, MC 2.1, MC 2.2, were implemented successfully, and then 3 points are given to each one. MC 1.2, MC 2.3, MC 2.4, MC 3.1, and MC 4.1 were implemented with average success, and 2 points are awarded to each one. MC 4.2 was implemented, thus zero point given to the method. MC 1.2 refers to wall insulation, the type of insulation used for walls is glass wool, while the results shows that, extruded polystyrene is best choice to be used in both walls and roofs. MC 2.3 refers to window glass thickness, 4mm glass were used for ecological building window, while the results shows that 6 mm works better in term of energy. MC 2.4 refers to the gas infill type and thickness, the type used for building is argon while the results of analysis shows that xenon is better to be used in window.

MC 3.1 refers to wall material, the type used in the building is reinforced concrete. But the use of AAC blocks showed better performance and could be economic. Finally, MC 4.2 is not awarded any point because no local shading is used in the building design. However, trees are surrounding the building in the south face for shading. This could be efficient, but it is not included in the design criteria as part of this study.



Consequently, the ecological building design is 83% successful in implementing the rules related energy conservation EC, and 77% successful in implementing the rules related materials conservation MC. As a result, the building is 80% (excellent) successful in following and applying the design rules and ontologies related building energy performance facets including both energy conservation and material conservation facets. Thus, the created local energy performance assessment scheme will help us to discover how the building is energy efficient and how much optimization can be achieved when adopting the rules-based design correctly.

In general, the building is efficient in term of energy performance. Mostly, efficient design decision has been made for the building. However, there is an opportunity to optimize the building design to be more efficient by implementing all the developed rules-based design and correctly adopting them in the building design.

### **7.5. Conclusion**

In this chapter, the last two components of the proposed framework in chapter 5 were identified. Firstly, the design rules considering local environment conditions are developed. This was done by adopting passive design strategies for energy efficient buildings, and then the impact of different design parameters related to these strategies are studied and simulated by using BIM. Thus, rules-based design optimization is developed (see table 7.18). The application of these rules in the construction design will ensure sustainable building design by eliminating building's negative environmental impacts, as well as improving its energy performance. This statement is approved by using BIM to study the impact of different design alternatives.

Secondly, based on the identified design rules and criteria, an energy assessment scheme similar to LEED and BREEAM was also developed. This was done through developing a scoring scale of four levels, each level set a number of points for how successfully these rules are being implemented in the building design. Then, the created energy scheme, was used to evaluate the ecological building case study. The results showed that, the building is greatly efficient in term of energy performance by making average success equal to 84%. However, there could be an opportunity to optimize the building design by adopting all the design rules identified in table 7.18.

## CHAPTER 8

### THE OVERALL BIM BASED DESIGN FRAMEWORK

#### 8.1. Introduction

In the previous chapters, every effort has been made to recognize all the components critical to successful implementation of BIM for design optimization and energy efficient building performance. These components are considered and identified through different case studies. In this chapter, how the initial BIM framework was implemented to improve building design will be documented.

First, in chapter 5 an initial hypothetical BIM framework were proposed (see figure 8.1). This hypothetical framework consists of four main components, these are: a design optimization process, technology implementation, design rules and ontology reflecting local values, and finally a local energy performance assessment scheme.

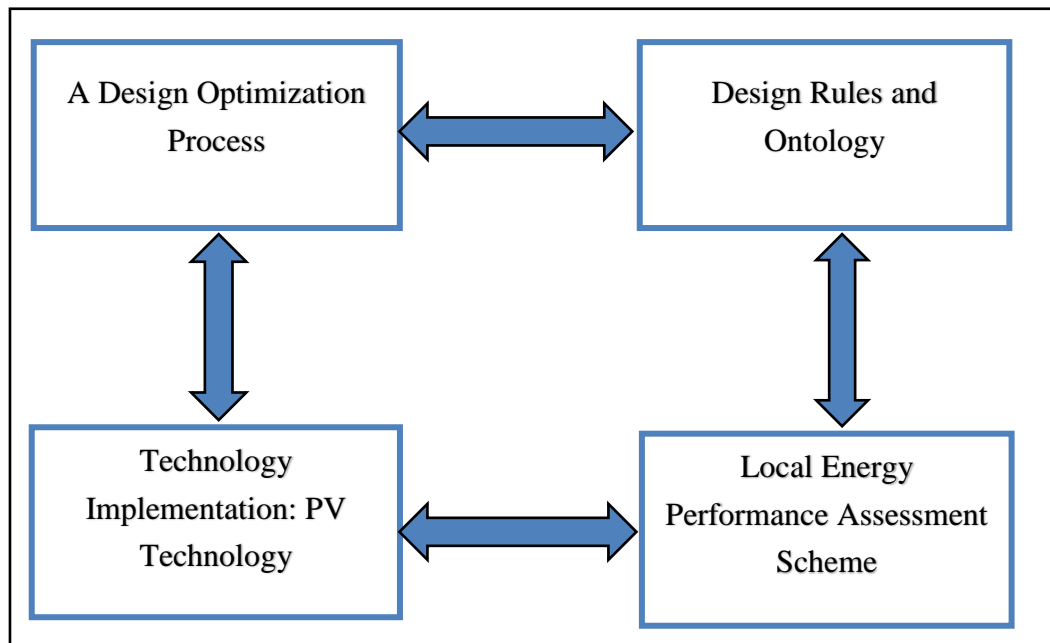
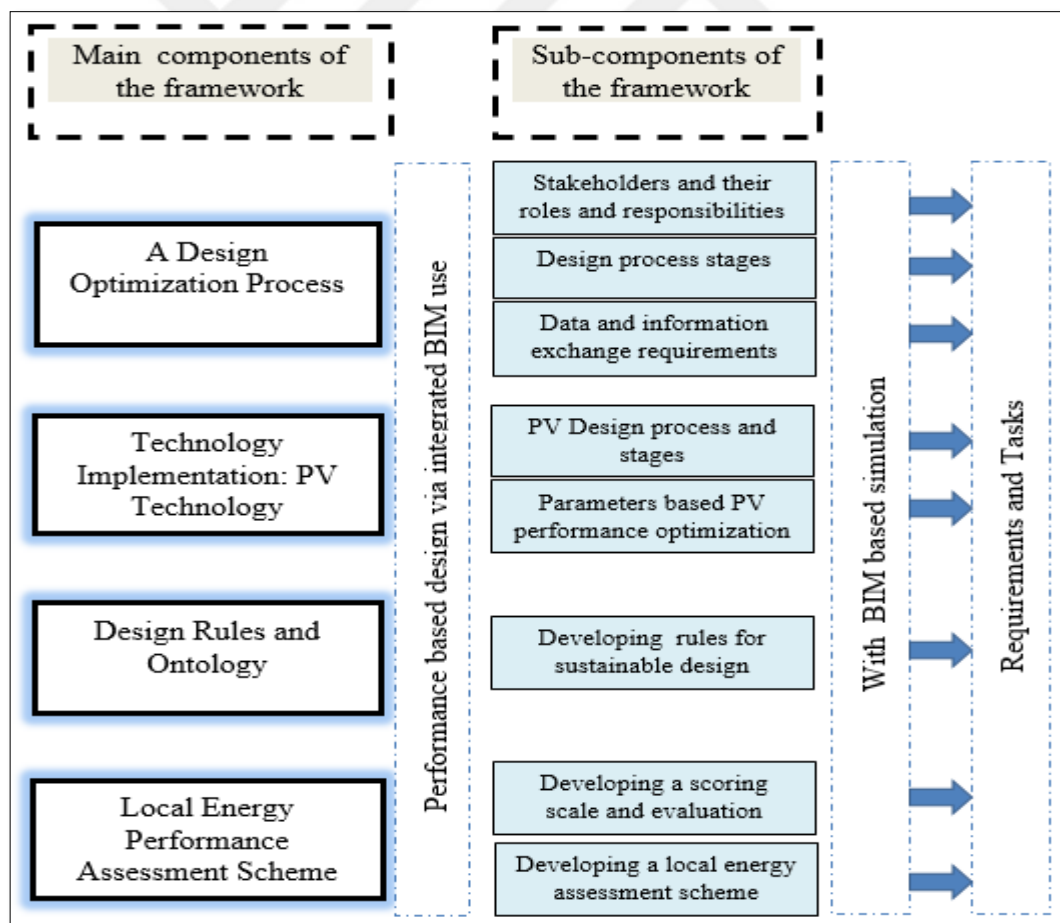

**Figure 8.1.** The initial BIM Based Design Optimization Framework

Then in the following chapters, multiple case studies were conducted to identify these components. In chapter 6, the first two components which are a design and optimization process, and technology implementation were considered through ARBIM building case study and the key aspects of these components were identified. While in chapter 7, the other two components were recognized through ecological building case study, and the key findings of each of them were identified.

## 8.2. Enhancement of the Implemented BIM Framework

When starting out on the journey of the BIM framework implemented in the previous chapters, the various components considered in the framework and the many tasks to be achieved may be somehow fragmented. For this reason, it is necessary to set out all the main and sub-components together with the tasks required to achieve these components in the framework as shown in figure 8.2. This will lead to an agile framework for effective use of BIM in the early design stages for any projects.



**Figure 8.2.** The main and sub-components, and tasks required for BIM implementation framework

In developing strategic BIM based design implementation framework, we included the main components that consider sustainable design requirements. Then, through the application of multi case studies adopting integrated BIM use for performance-based design, different objectives were considered as sub-components to the main components included in the framework. Finally, based on the results of BIM based simulation, the required tasks that go to make up the sub-components were identified. These tasks are differs based on the requirements of each components (see figure 8.2).

Having established a new improved BIM framework, in the following sub sections a review will be given for the main and sub components considered in the framework. This is followed by stating and identifying the required tasks for each component. This have represented in figures or tables. Finally, all the identified tasks together with main and sub components will be documented in a tabular form presenting the overall BIM framework to be implemented for building design optimization in Turkey.

### **8.2.1. Component 1: a design optimization process**

For any organization to be successful in achieving energy efficient building design, an effective and integrated design process and optimization is needed in the early design stage. This design process would require describing the stakeholders involved in the process and identifying the process stages which sets the flow of activities and roles played by each actor involved together with the information exchange requirements during the process.

In chapter 6, an attempt was made to achieve a strategic performance based design through integrated BIM use, both Revit architecture (BIM) tool and design builder (BPS) tool were used to design and optimize the building model by studying the impact of different design alternatives on the building energy consumption. Thus, the design of lower energy consumption was chosen. Such an incorporated building performance analysis requires the integration of multi actors such as clients, architects, engineers, and energy experts. Then, a process modelling which illustrate the flow of activities required by each actor, the roles and responsibilities played by each one of them, and the data and information exchange requirements was developed as shown in figure 8.3.

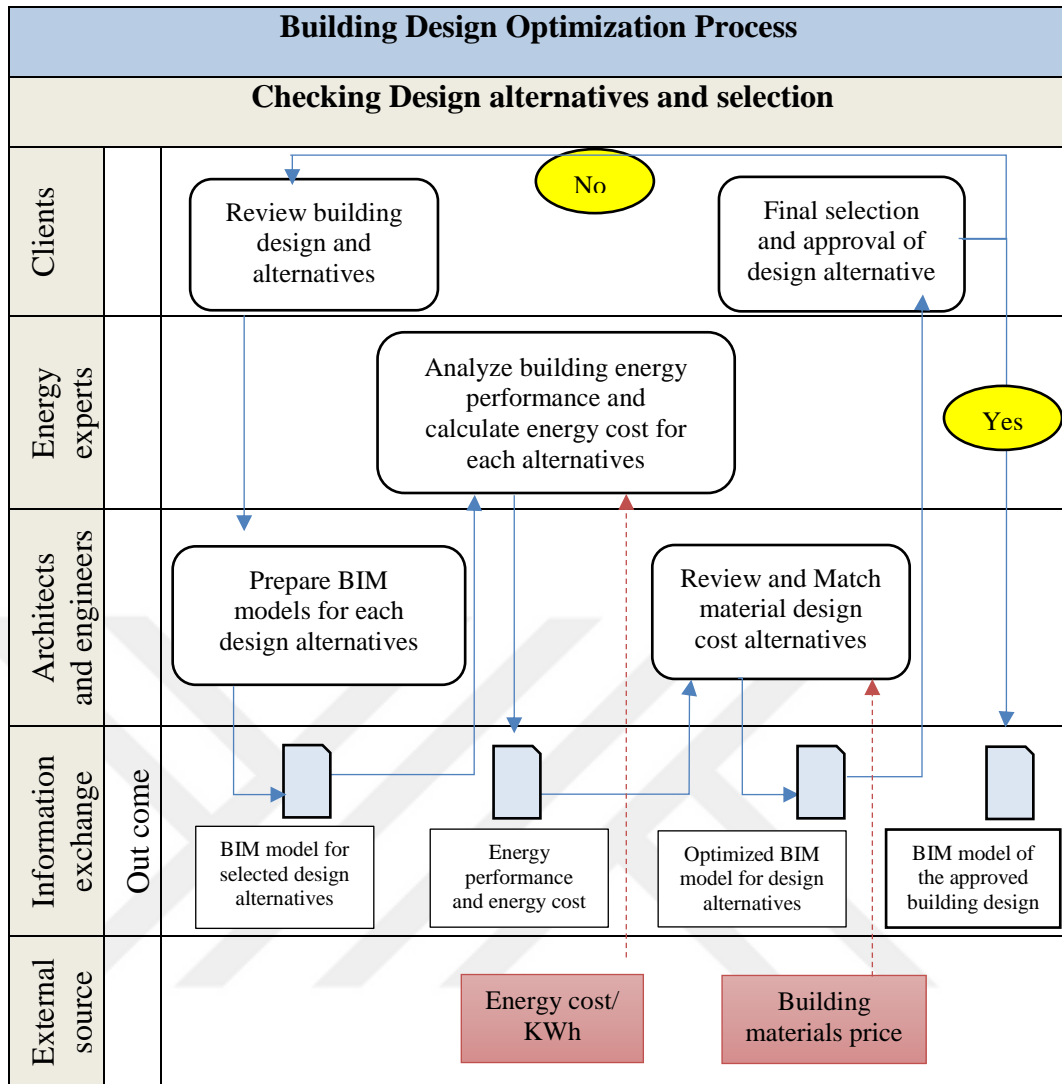

**Figure 8.3.** Stakeholders, and process stages and tasks required

The proposed workflow starts with the clients receiving the energy performance of the actual building model and suggesting alternatives in a collaborative manner with architects and engineers based on the materials availability, economic and aesthetic needs. Then the architects will create the building design model and alternatives by using Revit and prepare them for energy analysis. The selected design models will be transferred to the energy expert who will perform the analysis for each one of them by using design builder and calculate their energy performance and cost. The analysis results will be delivered to the architects and engineers who will also calculate the cost of each design alternatives and make some changes on the building design based on the energy performance, energy cost, and materials cost for each design alternative. Eventually, all of design alternatives are shared with the clients, who will choose the best one by comparing all design alternatives based on economical, energy efficient,

and aesthetic needs. Appropriate method for data exchange between BIM and energy analysis application should be specified as illustrated in figure 8.4.

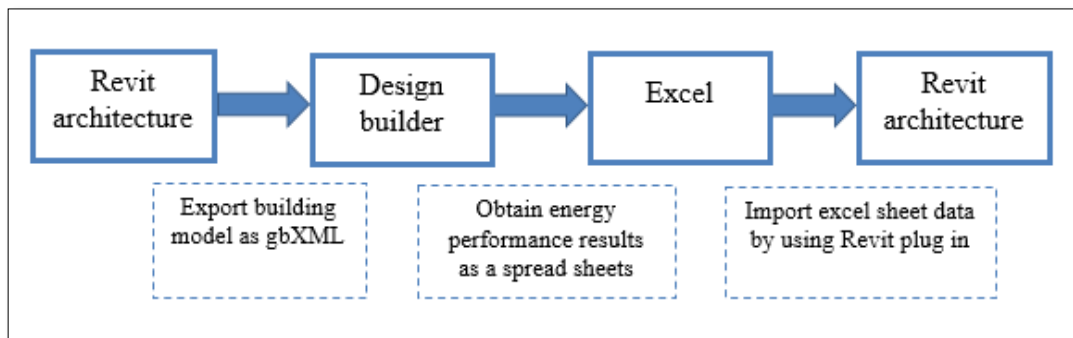

**Figure 8.4.** Data and information exchange requirements

First, to perform the energy analysis of building design, a gbXML file was used to export the building design model from Revit architecture to design builder. Then the obtained results from design builder was saved as excel spread sheet. Finally, from the Revit plug-in, excel importer tool was downloaded and used to import the obtained results and make required changes in the building design.

### **8.2.2. Component 2: technology implementation (PV technology)**

One of the most appropriate strategies for designing low energy building is the use of advanced building technology and renewable energy system such as PV technology. Thus, it's necessary to include such technologies in the building design. To do that, design builder software is employed for successful design of PV system.

It is important in the early stage that the designers should know what the steps are needed to correctly design a PV module with an optimum energy generation. This was done in two stages. In the first stage, an effective and detailed procedure to design a PV module is identified by adopting a real manufacturer specification. Then in the second stage, the design parameters that would lead optimize the PV performance are considered and simulated. These parameters are, PV orientation, PV tilt angle, and row distance between PV arrays. The simulation results showed that, optimum PV module performance can be achieved when orienting PV module toward south with tilt angle of 30 degree. Moreover, when there is more than one PV array, the spacing between them should not be less than 2 m. Figure 8.5, shows the steps required to design PV system by using design builder.

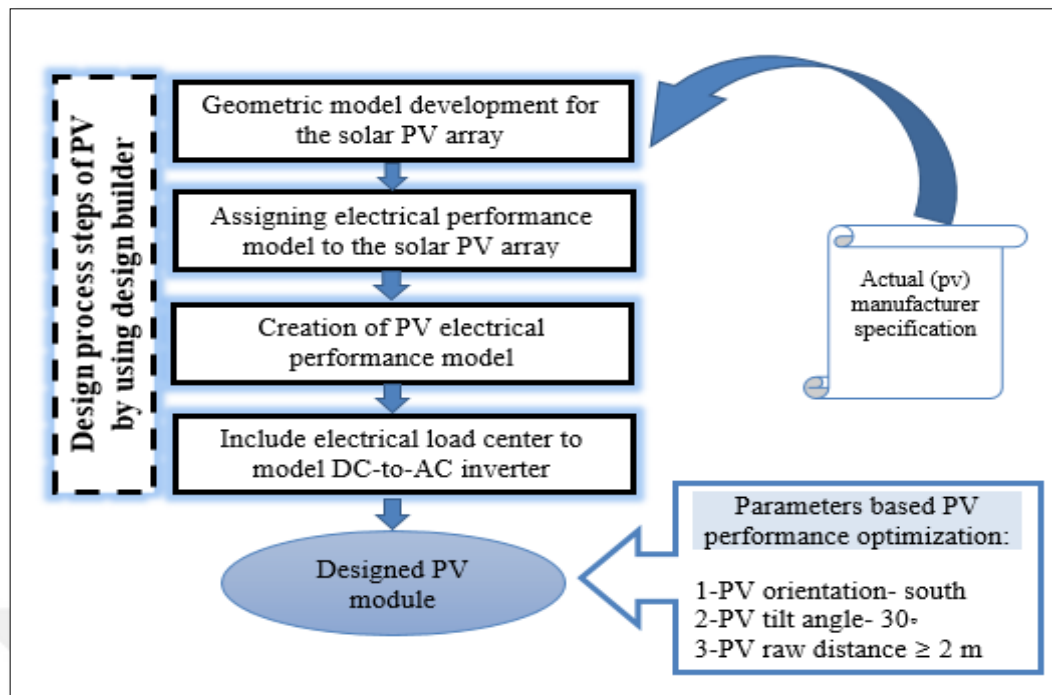

**Figure 8.5.** Design process steps of PV by using design builder

### 8.2.3. Component 3: design rules and ontology

To make a good energy saving, sustainable design should be implemented at the early design stage. Therefore, it's necessary to consider ecological design strategies. These strategies promise building design including building materials reflecting local environment conditions, reduces building energy consumption, and uses renewable technologies such as solar energy.

At the early design stage, designers are required to make good design decisions. Thus, they have to investigate different design alternatives and choose the most energy efficient one. For this reason, various simulations were done about the design parameters and alternatives, also their impacts on building energy performance were documented. Based on the simulation results, the actual design and alternatives were ranked from best to less energy efficiency. Accordingly, a couple of rules which reflects local environment conditions were formulated. These rules are divided into two design criteria: energy conservation and materials conservation. In these subdivisions the main output of simulations and the formulated rules are described in detail (table 8.1).

**Table 8.1.** Building Design Rules and Ontology

Building Design Rules Reflecting Local Values						
Rules based building design			Rules based building design			
Energy conservation criteria	Building orientation	Long length walls should be facing north-south orientation	Material conservation criteria	Insulation materials	Extruded polystyrene XPS for roof	
		Bigger glaze area should be facing south orientation			Extruded polystyrene XPS for wall	
	Building form	Rectangular shape		Window system	Window system-triple window	
		Shape factor = 2.89			Glazing type- low e coating	
	Green roof	Green roof application			Glass thickness- 6mm	
	Proper use of PV	Orientation- south			Raw spacing $\geq 2$	Gas infill type- Xenon
						Tilt angle= 30
		Wall material				Autoclaved aerated concrete (AAC)
				shading		Window shading- slatted blind high reflectivity
	Local shading- overhang and fin with projection of 0.5 m					

The application of these rules in the construction design, will ensure sustainable building design by eliminating building’s negative environmental impacts, as well as improving its energy performance. This statement is approved by using BIM and BPS tool to study the impact of design parameters and their alternatives on building performance.



#### 8.2.4. Component 4: local energy performance assessment scheme

A range of information about the building energy performance can be provided by the so called energy assessment scheme including information for enhancing the energy efficiency of buildings. Rating and assessing the building can be as a good advice to the building owners to enhance the building performance and achieve better ratings as it include recommendation to upgrade the building design.

A local energy assessment scheme has been developed in chapter 7. This was done in two stages. In the first stage a benchmark table which include a couple of rules related to building design parameters reflecting local environment conditions and energy efficient building materials is developed. This already has been done under the third component of the adopted BIM framework (see table 8.1), where a set of building design parameters were simulated and then, based on the simulation results a couple of rules which represent the best design decision were formulated. In the second stage, an evaluation scoring scale legend has been created. This scoring scale consist of four scoring levels starting from successful implementation of the rules to not implemented level, then a few points are given to each of them (see table 8.2). The rank of points is given based on the rank of the simulated design parameters and their alternatives from best to less impacts on building energy performance.

**Table 8.2.** The evaluation scoring scale legend

<b>Points (*)</b>	<b>Grades for the Implementation of Design Rules</b>
0	Not implemented
1	un successful implementation
2	Average successful implementation
3	Successful implementation

Having the rules that represent the best design decision with the created scoring scale legend, any building design can be assessed and evaluated, and its level of success can be calculated. To do that, it's required to assess the energy performance of the actual building design and system. This can be carried out by an assessor who will collect information on the building properties and the materials used in the building. The collected information will be compared with the design rules and available alternatives to determine their level of success in following these rules. Then, a few points will be

given to each design parameters based on the developed scoring legend. Accordingly, the final results of the design evaluation can be calculated, providing a mean on how the building design is efficient in term of energy performance (see table 8.3).

**Table 8.3.** The local energy performance assessment scheme

<b>Local Energy Performance Assessment Scheme</b>								
	<b>Rules based building design</b>		<b>Points (*)</b>		<b>Rules based building design</b>		<b>Points (*)</b>	
	<b>Energy conservation (EC)</b>	Orientation EC1	EC 1.1		*	<b>Material conservation (MC)</b>	Insulation (MC1)	MC 1.1
EC 1.2			*	MC 1.2	*			
Building form (EC2)		EC 2.1	*	External window (MC2)	MC 2.1		*	
		EC 2.2	*		MC 2.2		*	
Green roof (EC3)		EC 3.1	*		MC 2.3		*	
		PV technology (EC4)	EC 4.1		*		MC 2.4	*
EC 4.2			*		MC 2.5		*	
EC 4.3			*	External window (MC3)	MC 3.1		*	
<b>Total point achieved</b>			**	<b>Total point achieved</b>			**	
<b>Section points</b>			24	<b>Section points</b>			30	
<b>Success level %</b>			**	<b>Success level %</b>			**	
<b>Total success = **%</b>								

As shown in table 8.3, the established assessment scheme consists of two design criteria sections, one for energy conservation (EC) design criteria and the other for material conservation (MC) design criteria. For each one of these design criteria's different design strategies and rules are considered. The total points awarded for energy conservation and material conservation sections are equal to 24 points and 30 points respectively. Accordingly, the average of both sections determines the total success in implanting the established design rules and ontology. Thus, it determines how much the building design is efficient in term of energy performance.

### 8.3. The Overall BIM Based Design Optimization Framework

In the previous section, a review was made for the main components considered in the framework, and the required tasks to achieve each one of them successfully were identified. Thus, in this section, the overall framework including the main and subcomponents together with the required tasks are documented. This will result in a program of tasks providing all the information needed to ensure sustainable building design by proper adopting of BIM framework in the early design stage (see table 8.4).

**Table 8.4.** The overall BIM based design optimization framework

Main components of the framework		Sub-components	Requirements and Tasks		
Component 1	A Design Optimization Process	Stakeholders	Engineers, architects, energy experts, and clients		
		Process stages and tasks (see figure 8.3)	clients	Review building design and alternatives	
			Architects engineers	Prepare and check the selected alternatives for energy analysis	
			Energy experts	Analyze actual building energy performance and alternatives	
			Architects engineers	Review design alternatives with energy performance and cost results	
			clients	Final selection and approval of a design alternative	
			Data and information exchange requirements (See figure 8.4)	<u>Revit to design builder</u> : export the building model as gbXML	
		<u>Design builder to excel</u> : obtain the energy performance results of the building model			
		<u>Excel to Revit</u> : import the results in Revit to make changes in the building design by using Revit plug in (Excel importer)			

Component 2	Technology Implementation (PV Technology)	PV design process by using Design Builder (see figure 8.5)	Geometric model development for the solar PV arrays	
			Assigning electrical performance model to the solar PV array	
			Creation of PV electrical performance model by using and actual manufacturer specification	
			Include electrical load center to model DC-to-AC inverter equipment	
		Parameters based PV performance optimization	Proper selection of PV modules orientation by directing them toward south orientation	
			Installing the PV modules at tilt angle of 30 degree	
Row spacing between PV arrays should not be less than 2 m				
Component 3	Design Rules and Ontology	Rules based design (see table 8.1)	Building orientation	Long length walls should be facing north- south direction, with bigger glaze facing south
			Building form	Building form should be rectangular with shape factor of 2.89
			Green roof system	Intensive green roof, (LAI= 4, plant height= 0.8)
			PV technology	Same applied in component 2, PV technology
			Insulation materials	The use of extruded polystyrene for both walls and roofs

			Window system	Triple glaze 6 mm- low e-16 mm xenon gas infill
			Wall materials	Autoclaved aerated concrete block (AAC)
			Shading	Slatted blind for window shading, and (overhang and fin) of 0.5 m projection for local shading
Component 4	A Local Energy Performance Assessment Scheme	A scoring and evaluation scale legend (see table 8.2)	Determining how successful each developed rule in component 3 are being implemented in building design	
		A local energy performance assessment scheme (see table 8.3)	Assessing and evaluating the building design based on the scoring scale legend, and developed design rules	

As shown in the table 8.4, the overall BIM framework is documented, providing all the requirements and tasks needed for proper BIM framework implementation. Moreover, this framework represent the final outcome that has novelty on its own and could be the response to the research problem through the comprehensive perspective in terms of design and optimization process, technology implementation such as PV, design rules and ontology reflecting local values, and finally local energy performance assessment scheme.

It's believed that this overall framework will impact the design process by allowing the engineers and designers to examine and investigate important design criteria and helping them to make informed design decision. Many design alternatives can be analyzed very quickly in the early design stage. This is due to existence of well-developed design process which identifies all the roles and responsibilities of the team

members involved in the process employing an effective method for data and information exchange during the design process.

The framework also provide the engineers an opportunity to ensure more efficient building design by adopting renewable energy practices such PV technology. By using design builder software and following the identified design steps, an effective PV system can be designed which ensures maximum performance, this is by adopting the main design parameters identified previously.

Furthermore, the developed framework ensures efficient building design by suggesting effective rules related to building design. It is known that the traditional design technique has some shortages because this method may contain assumptions based on the rule of thumb which can be it may include simplified assumption based on rules-of-thumb which can be incorrect. Moreover, it may also prefer the aesthetic need without performance calculations. Therefore, having the developed rules in hand may lead to efficient building design which promises less energy consumption and consequently less environmental impacts

Finally, the developed framework proposes a local energy performance assessment scheme. It is believed that this local scheme can be as a significant and vital source of advices to the engineers and owner as it provides information about how the building is efficient in term of energy performance. The main feature of this scheme is that it considers the rules-based building design reflecting local environment. Thus, providing recommendations to enhance the building performance for better rating.

#### **8.4. Conclusion**

In this chapter, the overall BIM based design optimization framework which was developed through the application of multi case studies was described. This was done by detailing the main and subcomponents included in the framework with the required tasks to be achieved for best implementation of the framework. This was followed by documenting the overall improved framework in a tabular form. It is believed that this will provide a better more developed framework which can successfully be implemented in the design optimization for buildings in Turkey.

Consequently, this framework explores the role of BIM in optimization building design toward sustainability and energy efficiency, bringing more attention to

successful technology implementation such as PV system, identifying the best decisions to be made in term of building design parameters and strategies, and finally providing a mean on how building design is efficient in term of energy performance.



## CHAPTER 9

### THE VALIDATION OF THE OVERALL BIM BASED DESIGN AND OPTIMIZATION FRAMEWORK

In the previous chapter, the overall performance-based design framework was documented including the original and subsequent components together with the tasks and requirements needed to achieve these components successfully. This framework represents a holistic design and optimization approach through a comprehensive perspective in terms of design and optimization process, technology implementation such as PV, design rules and ontology reflecting local values, and finally local energy performance assessment scheme.

In this chapter, the overall framework will be tested on a real project building case study. This is to examine its efficiency and effectiveness and also to show how this framework can be implemented successfully in order to expand the searching space for the best design solutions and reduce time of the process for effective design results, which in turn will help the designers to design an economic and environmentally friendly buildings design.

The validation will be examined in three stages, starting with the building design process by using BIM which is identified under the first component of the framework, simulating and analyzing the building design performance and alternatives by considering the rules-based design which are identified under the second and third components of the framework. Finally, evaluating and assessing the energy performance of the actual building design by using the local energy assessment scheme which is identified under the fourth component of the framework.

#### **9.1. The Building Design Process (Health Center Building) Case Study**

The building has been constructed in Hasan Kalyoncu University, Gaziantep in Turkey. The building is a university construction, it is a three-story building.



Following the identified design process under the first component of the framework, a 3D building geometry is created by using Revit architecture (see figure 9.1), and then transferred to design builder software through gbXML (see figure 9.2).



**Figure 9.1.** 3D geometry of the health center building model

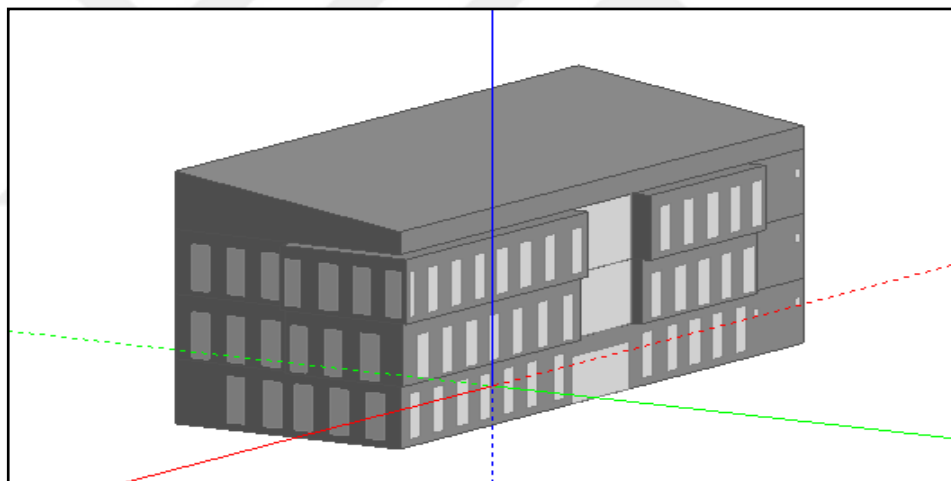

**Figure 9.2.** Building model in design builder

This is to analyze and simulate the actual building energy performance. Once the building is transferred to Design builder, then all the information related to physical properties of the building is loaded in order to define the actual properties of the building model and prepare it for energy performance analysis. The needed information can be divided into two categories: building location and orientation, and physical properties of the building construction elements including: external wall, internal wall, floors, roofs, glazing, lighting and HVAC system used in the building. Once the building properties is loaded, then the actual energy performance of the building is calculated.

### 9.1.1. Building location and orientation

The location chosen was Gaziantep-Turkey. The longitude and latitude of the chosen location are 37.37° E and 37.08° N respectively, the altitude is 832 meters above sea level, the actual site orientation is at 60°. This means that the front side of the building is facing south-west direction.

### 9.1.2. The properties of the building materials

The actual physical characteristic and properties of the building elements and materials used the building design model are presented in table 9.1.

**Table 9.1.** The physical characteristic of the actual building model

Building components	Materials layers	Thickness (m)	U-Value (w/m <sup>2</sup> .k)
External wall	Natural stone	0.07	0.447
	Cement mortar	0.03	
	Gas concrete AAC block	0.20	
	Gypsum plaster	0.02	
	Painting	0.002	
Internal wall	Internal painting	0.002	1.514
	Gypsum plaster	0.002	
	Cement mortar	0.01	
	Brick aerated	0.1	
	Cement mortar	0.01	
	Gypsum plaster	0.002	
	Internal painting	0.002	
Floor	Granite tiles	0.02	2.237
	Cement mortar	0.02	
	Concrete light weight (proofing)	0.02	
	Reinforced concrete	0.35	
Flat roof	Concrete light weight proofing	0.05	0.538
	Insulation materials (rock wool)	0.06	
	Concrete reinforced	0.35	
	Suspended ceiling	0.01	
Pitched roof	Clay tile roofing	0.015	0.566
	Roofing felt	0.005	
	Water proofing (PVC)	0.02	
	Wood panels	0.02	
	Insulation materials rock wool	0.06	

Regarding the type of the window and glazing used for the building, the characteristics of the window materials are shown in table 9.2.

**Table 9.2.** The properties of window system used for the building

Glaze type	Thicknes s(mm)	Frame	Total solar transmission (SHGC)	U- value (W/m2. k)
Double glazing clear-13mm air	4 mm	Aluminum	0.395	0.852

As shown in table 9.2, a triple glazed façade is used which consists of three layers of 4mm low e glass with 16 mm argon gap, the frame type is aluminum.

### 9.1.3. The actual building energy performance

Once the properties of the building elements are loaded in the building model, then the actual building design is simulated and then its energy performance is calculated. Figure 9.3 shows the calculated amount of the energy consumed and CO<sub>2</sub> emitted by the actual building design.

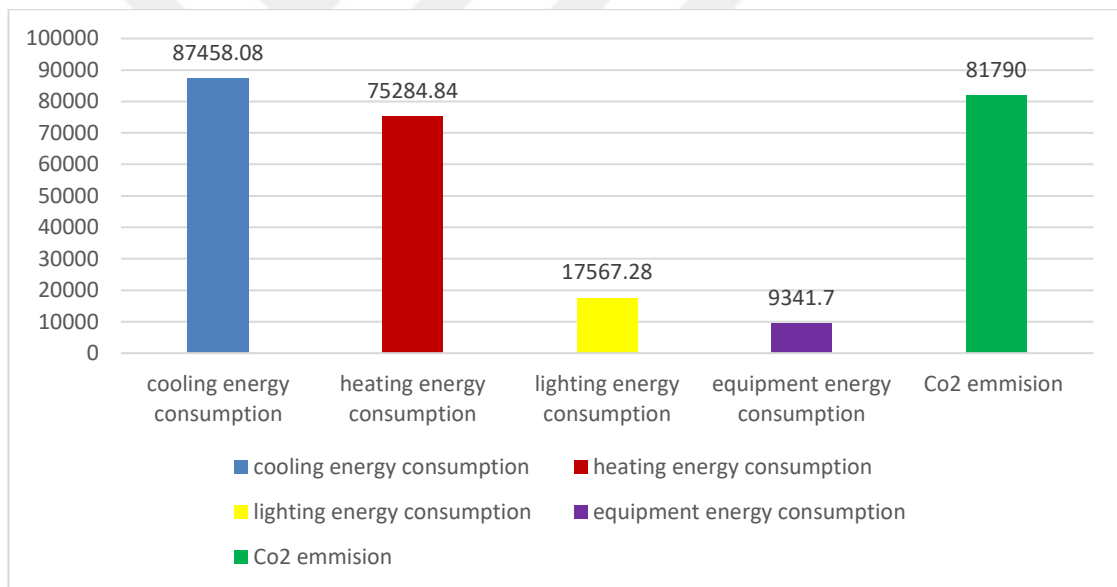

**Figure 9.3.** The actual building energy consumption

As shown in figure 9.3, the calculated amount of cooling and heating energy consumption are equal to 87458.08 (KWh), 75284.84 (KWh) respectively, while the energy consumed for lighting and equipment are equal to 17567.28 (KWh) and 9341.70 (KWh) respectively, making an annual energy consumption equal to 189651.62 (KWh) and annual CO<sub>2</sub> emission equal to 81790.76 Kg.

## 9.2. Building Design Optimization

Since the main aim is to validate and check the efficiency and effectiveness of the overall BIM based design framework. Therefore, in the second stage, the possibility of optimizing the building design by using the identified design rules related to the building design parameters and PV technology implementation will be examined. This will be done by analyzing and simulating the performance of the actual building design and alternatives considering the identified rules within the framework. Finally, based on the analysis results, the total energy performance of the actual and optimized building design will be assessed and evaluated by using the local energy assessment scheme identified in the last component within the overall BIM framework.

### 9.2.1. Building orientation

The orientation of the actual building model is facing the south-west direction. While, the optimum orientation estimated previously confirmed that buildings should be facing south direction. Therefore, to check whether the south orientation is the best decision to make, different orientation including both actual and the optimum direction are simulated and their impacts on the energy performance are calculated. The results are illustrated in table 9.3.

**Table 9.3.** The impact of different building orientation on energy consumption

<b>Orientation</b>	<b>Heating energy consumption (KWh)</b>	<b>Cooling energy consumption (KWh)</b>	<b>Annual energy consumption (KWh)</b>	<b>Annual CO<sub>2</sub> emission (Kg)</b>
South-west	75284.84	87458.08	162742.92	81790.76
North (0°)	78343.88	68799.63	147143.51	74150.25
South (180°)	66872.59	72475.52	139348.11	72367.56
East (90°)	71683.41	89017.62	160701.03	81417.23
West (270°)	77777.46	88460.03	166237.49	83004.80

As shown in table 9.3, when the building is facing the south direction, less energy consumption will be achieved when compared to the actual building orientation, making an annual energy saving equal to 23394.81 KWh and annual reduction in CO<sub>2</sub> emission equal to 9423.2 Kg. Consequently, the simulation results confirmed that the rule related building orientation is accurate to be implemented for any building design in which the building should be directed to the south in away the long length walls

facing the south-north direction and bigger glaze area should be stored at the wall facing south direction.

### 9.2.2. Building form

The building design is critical for achieving efficient energy building. The actual form adopted for the building design is rectangular. The shape factor, which represents the proportion of building length to its width is equal to 2.69 (wall length= 42m, walls width=15.6m). The rule related to building form confirmed that the building should be rectangular, and the shape factor should be equal to 2.89. Therefore, to check the accuracy of this rule, different building forms including the actual and optimal building form are designed, analyzed, and their impacts on building performance are calculated.

The results are illustrated in table 9.4

**Table 9.4.** The impact of building form on building energy performance

Shape factor (X/Y)	Long length walls (X)	Short length walls (Y)	Cooling energy consumption (KWh)	Heating energy consumption (KWh)	Annual energy consumption (KWh)
2.69	42	15.6	72475.52	66872.59	139348.11
2.89	43.5132	15.057	66872.59	63229.12	138216.23
3.24	46.073	14.22	73041.45	66728.54	139769.99

As shown in table 9.4, a rectangular building form with shape factor equal to 2.89 will achieve the less energy consumption when compared to the actual shape factor adopted for the building design, making an annual energy saving equal to 1131.88 KWh. These results confirmed that the rule related building form is valid and appropriate to be implemented for any building design in which the building form should be rectangular, and the shape factor should be equal to 2.89, which means that the length of walls should be 2.89 times bigger than width.

### 9.2.3. PV technology

Using renewable energy such as PV technology is the most appropriate strategy for designing low energy building especially in Turkey, this is due to its geographic location which has many benefits to use renewable energy resources typically solar energy.

In the actual building design, the decision was made to use poly crystalline solar panels. These solar panels were stored at the pitched roof of the building at tilt angle of  $16^\circ$  and orientation of south-west. Regardless of the number of panels used for the building, the researcher will follow the explored process steps in chapter 6 to design PV modules and simulate the impact of PV performance parameters including PV orientation and PV tilt angle. The row distance between PV panels is not included in this case, because the PV panels are already attached to the pitched roof which means that there is no mutual shading that may affect the performance of PV panels.

Following the design process steps explored in chapter 6, one PV array which contains of 10 modules with area of  $11.680 \text{ m}^2$  is created and attached to the actual building model (see figure 9.4).

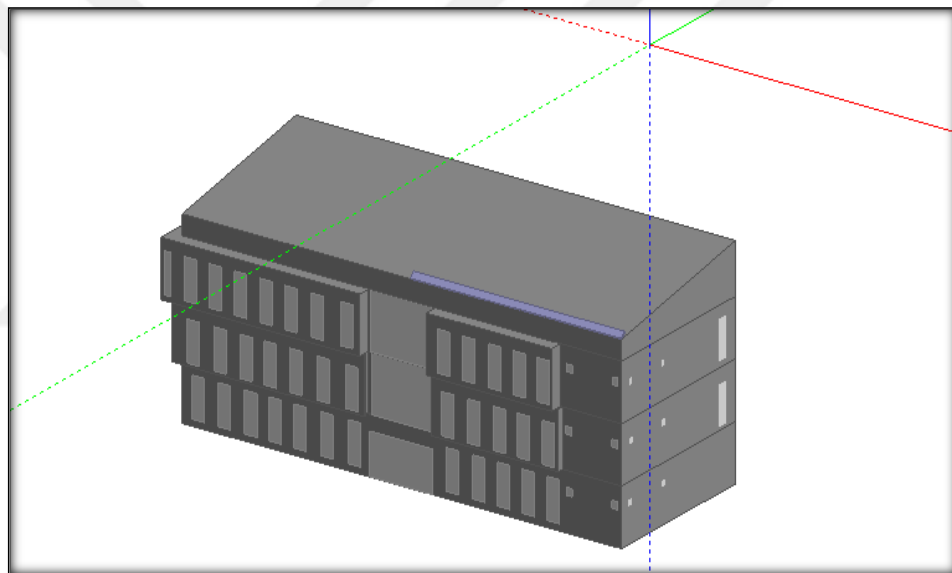

**Figure 9.4.** PV modules attached to the roof of the building

As presented in figure 9.4, 10 PV modules are created and designed in one series and attached to the roof of the building model. As mentioned in chapter 6, to optimize the performance of the PV panels, it necessary to take in account the parameters that may affect the performance of PV panels, these are PV orientation, PV tilt angle, and finally PV row spacing. The established rule related PV performance confirms the use of PV with south orientation and PV tilt angle of  $30^\circ$ . The row distance will not be considered in this case, because the PV panels are directly attached to the pitched roof which means that there is no mutual shading that may affect its performance. Therefore, firstly, different PV orientation are simulated, and then their impacts the PV modules are calculated are calculated. The results of the simulation are presented in table 9.5.

**Table 9.5.** The impact of PV orientation on PV efficiency

<b>PV orientation</b>	<b>PV area (M<sup>2</sup>)</b>	<b>Electricity generated (KWH)</b>	<b>Electricity generated/electricity consumed %</b>
<b>South- west (Actual)</b>	11.680	<b>3930.53</b>	<b>14.61</b>
south		4141.66	15.39
East		3736.10	13.88
North		3303.30	12.28
West		3724.24	13.84

As shown in table 9.5, the energy generation of the south-west PV orientation which was chosen for the actual building design is equal to 3930.53 KWh, covering only 14.61% of the electricity consumed. While the energy generation of south PV orientation is equal to 4141.66 KWh, covering 15.39% of the electricity consumed. Secondly, different tilt angle of PV module is simulated, and their impact on the PV energy generation are also calculated. The result is presented in table 9.6.

**Table 9.6.** The impact of PV tilt angle on PV efficiency

<b>Tilt angle of the PV array (degree)</b>	<b>PV array area (M<sup>2</sup>)</b>	<b>Electricity generation (KWh)</b>	<b>Electricity generated/electricity consumed %</b>
10°	11.680	4037.88	15.01
<b>16°</b>		<b>4141.66</b>	<b>15.39</b>
30°		4261.61	15.84
45°		4198.30	15.60

As shown in table 9.6, the PV tilt angle of 16° which is used for the actual building generates 4141.66 KWh and covers 15.39 of the total electricity consumption. While the PV tilt angle of 30 will perform the best when compared to the actual tilt angle, it generated 4261.61 KWH and covers 15.84 of the total electricity consumption. Consequently, the simulation results of PV orientation and PV tilt angle confirmed the rule related PV performance in which the orientation of PV panels should be facing south, and the tilt angle should be at 30°.

#### **9.2.4. Insulation material**

The use insulation materials in the building envelope is considered to be an effective way to reduce heating and cooling energy consumption and limit the negative

environmental impact of the building sector. The insulation of building envelopes makes a great contribution to building energy performance. Despite of its characteristics, other criteria such as the components to be installed, either wall or roof are also important to determine its effectiveness.

The insulation materials used for the roof of the actual building design is rock wool while there are no insulation materials used for the walls. The rules related insulation materials confirmed that the use of extruded polystyrene for both roofs and walls is the best material to be used. Therefore, to check the validity of this rule different insulation materials including the actual material used for the building and the best material to be used for both walls and roof are simulated. The results are presented in table 9.7 and table 9.8.

**Table 9.7.** The impact of roof insulation materials on building energy consumption

Roof insulation type	U- value (W/m <sup>2</sup> . k)	Heating energy consumption (KWh)	Cooling energy consumption (KWh)	Annual energy consumption (KWh)
Rock wool- (RW) (actual)	0.538	87458.08	75284.84	162742.92
Extruded polystyrene (EXP)	0.387	87442.87	75177.06	162619.93
Expanded polystyrene (XPS)	0.480	87452.43	75243.40	162695.83
Glass wool (GW)	0.435	87447.74	75211.60	162659.34

As shown in table 9.7, rock wool (RW) which is used for the actual building roof makes an annual energy consumption equal to 162742.92 KWh. While the use of extruded polystyrene (EXP) will lead to less energy consumption when compared to rock wool, making an annual energy saving equal to 122.99 KWh.



**Table 9.8.** The impact of wall insulation materials on building energy consumption

Wall insulation type	U- value (W/m <sup>2</sup> . k)	Cooling energy consumption (KWh)	Heating energy consumption (KWh)	Annual energy consumption (KWh)
No insulation (actual)	0.447	87458.08	75284.84	162742.92
Extruded polystyrene	0.236	85475.64	69890.14	155365.78
Expanded polystyrene	0.268	85708.02	70604.20	156312.22
Rock wool	0.285	85833.43	70969.20	156802.63
Glass wool	0.253	85601.46	70274.49	155875.95

As shown in table 9.8, using extruded polystyrene to insulate the walls has better performance in term of energy when compared to the other insulation materials. It's also worth mentioning that when insulating the walls with extruded polystyrene will lead to a great energy saving when compared to non-insulated walls, making an annual energy consumption equal to 7377.14 KWh. Consequently, the results confirmed the accuracy of the rule related the type of insulation material to be used for both roof and wall in which extruded polystyrene should be used for insulating both (roof and wall).

#### 9.2.5. Building external windows

Windows are considered as crucial in the building design in which it play a significant role in eliminating the overall building energy consumption. The parameters which may affect window performance can be analyzed based on the glazing types and thicknesses, glazing layers, and the gas infill type and thicknesses.

The rule related window system type confirmed the use triple 6mm low e glazing-16mm xenon gas infill gap. Therefore, to check the validity of this rule, different analysis and simulation is conducted regarding the window type, glaze type and thicknesses, and gas infill type and thicknesses and their impacts on building energy performance is calculated. Firstly, three types of window system are simulated and analyzed in term of energy performance. The results of window type's simulation are presented in table 9.9.

**Table 9.9.** The impacts of window system types on building energy consumption

Window system type	U- value (W/m <sup>2</sup> . k)	SHGC	Cooling energy consumption (KWh)	Heating energy consumption (KWh)	Annual energy consumption (KWh)
Double glazing 4mm (actual)	2.827	0.742	87458.08	75284.84	162742.92
Triple glazing 4mm	1.868	0.658	81332.12	72344.72	153676.84
Single glazing 4mm	5.806	0.847	92452.59	87244.98	179697.57

As shown in table 9.9, the use of triple glazing will lead to the best energy performance when compared to double glazing (which is used for the actual building), making an annual energy saving equal to 9066, 08 KWh. In the second step, different glazing types are simulated including clear glazing, low emissivity glazing, tinted glazing, and reflective glazing and their impact on building energy performance are calculated, knowing that the glazing type used for the building is clear glazing. The results of glazing type simulation are presented in table 9.10.

**Table 9.10.** The impact of glazing types on building energy performance

Glazing type	U- value (W/m <sup>2</sup> . k)	SHG C	Cooling energy consumption (KWh)	Heating energy consumption (KWh)	Annual energy consumption (KWh)
4mm glazing clear	2.827	0.742	87458.08	75284.84	162742.92
4mm glazing low e	1.557	0.380	57113.30	83480.76	140594.06
4mm glazing tinted	1.867	0.571	45357.69	103351.05	148708.74
4mm glazing reflective	2.387	0.185	41050.16	103221.18	144271.34

As shown in table 9.10, the clear glazing which is used for the actual building will lead to an annual energy consumption equal to 162742.92, while the use of (low e glass)

will perform the best in term of energy performance when compared to the actual glazing using for the building, making an annual energy saving equal to 22148.86 KWh. As a result, the rank of glazing types from best to less impact on energy performance are as follows: low e glazing, reflecting glazing, tinted glazing, and finally clear glazing.

In the third step, different glazing thickness are simulated including thicknesses of 3mm, 4mm, and 6mm, and then their impact on building energy performance are calculated. The results of thickness simulation are presented in table 9.11.

**Table 9.11.** The impact of glazing thickness on building energy performance

Glaze thickness	U- value (W/m <sup>2</sup> . k)	SGHC	Cooling energy consumption (KWh)	Heating energy consumption (KWh)	Annual energy consumption (KWh)
Double 4mm	2.827	0.742	87458.08	75284.84	162742.92
Double 3 mm	2.837	0.764	88904.79	74532.53	163437.32
Double 6 mm	2.795	0.716	85713.00	76092.83	161805.83

As shown in table 9.11, 4mm glazing which is used for the actual building will make an annual energy consumption equal to 162742.92 KWh, while the use of 6mm glazing for the same type will lead to less energy consumption when compared to 4mm glazing, making an annual energy consumption equal to 161805.83 KWh. This means that, replacing 4mm glazing with 6mm glazing will make an annual energy saving equal to 937.09 KWh. In the fourth step, different gas types which infill the gap between the glazing layers are simulated, including air, argon, and xenon. Knowing that the type of gas used for the window of the actual building design is air. The results of gas type's simulation are presented in table 9.12.

**Table 9.12.** The impact of window gas types on building energy performance

Gas type	U- value (W/m <sup>2</sup> .k)	SHGC	Cooling energy consumption (KWh)	Heating energy consumption (KWh)	Annual energy consumption (KWh)
Air	2.827	0.742	87458.08	75284.84	162742.92
Argon	2.663	0.742	87851.84	74139.10	161990.94
Xenon	2.509	0.742	88415.17	72837.01	161252.18

As shown in table 9.12, the air gas which is used to infill the window layers of the actual building design makes an annual energy consumption equal to 162742.92 KWh, while the use of xenon gas will lead to less energy consumption when compared to air gas, making an annual energy consumption equal to 161252.18 KWh. This means that, the use of xenon infill gas will make an annual energy saving equal to 11490.74 KWh. Finally, different gas gap thicknesses are simulated including 13mm, 16mm, 10mm, and 6mm, and their impact on the building energy consumption are also calculated. Knowing that gap thickness used for the actual window design is 13mm. the results of gap thickness simulation are presented in table 9.13.

**Table 9.13.** The impact of window gap thickness on building energy performance

Gap thickness	U- value (W/m <sup>2</sup> . k)	SHGC	Cooling energy consumption (KWh)	Heating energy consumption (KWh)	Annual energy consumption (KWh)
13 mm	2.827	0.742	87458.08	75284.84	162742.92
16 mm	2.734	0.742	87680.05	74673.99	162354.04
10 mm	2.964	0.741	87136.21	76233.90	163370.11
6 mm	3.295	0.740	86380.73	78495.24	164875.97

As shown in table 9.13, the gap thickness of 13mm which is used for the actual window design makes an annual energy consumption equal to 162742.92 KWh, while the gap thickness of 16mm will lead to less energy consumption when compared to the actual window infill gap. This means that, changing the gap thickness form 13mm to 16mm will lead to annual energy saving equal to 388.88 KWh. In general, the simulation results of the window system types, glazing types and thicknesses, and gas infill types and thicknesses confirmed the rule related window design in which triple low e- 6mm, and xenon gas type of 16mm should be used for building external windows for the building in Gaziantep-Turkey.

#### 9.2.6. External walls

Walls are considered to be as a main part of the building envelopes because it provide thermal comfort inside the building by elimination the building energy use without affecting the appearance of the building.

The type of wall material used in the actual building design is gas concrete block (AAC). The established rule related wall material type confirms the use of AAC

concrete blocks. Therefore, in order to check the accuracy of this rule, different wall materials including AAC block, brick aerated, and normal concrete block are simulated and analyzed, and then their impact on building energy performance are calculated. The simulation results are illustrated in table 9.14.

**Table 9.14.** The impact of wall materials types on building energy performance

Wall material type	U- value (W/m <sup>2</sup> . k)	Cooling energy consumption (KWh)	Heating energy consumption (KWh)	Annual energy consumption (KWh)
Autoclaved concrete block (AAC)	0.447	87458.08	75284.84	162742.92
Brick aerated block	0.923	89608.58	85018.28	174626.86
Concrete block normal	1.236	91716.32	90904.95	182621.27

As shown in table 9.14, the gas concrete (AAC) block which is used for the walls of the actual building design lead to less energy consumption when compared to the other simulated material, making an annual energy consumption equal to 162742.92 KWh. Consequently, the results confirmed the accuracy of the established rule related wall material type in which AAC block is founded to be the best type to be used for building walls in Turkey.

### 9.2.7. Window shading

Proper selection of shade device play an important role in eliminating the cooling energy consumption and ensuring efficient energy performance. As mentioned in chapter 7, there are two type of window shading, these are internal shading and local (external shading).

The type of internal shading used for the actual building design is diffusion blind shade roll, the local shading is not applied and used for the building. The rule related both internal and external shading confirmed the use of slatted blind high reflectivity for internal shading and using (overhang and fin) with projection of 0.5m for external shading. Therefore, to check the validity of this rule, different simulation is carried out regarding the both type of shading.

Firstly, different types of internal shading including drapes-close weave, slatted blind high reflectivity, and diffusing blind-shade roll shading are simulated and their impacts on building energy performance are calculated. The simulation results are presented in table 9.15

**Table 9.15.** The impact of internal shading types on building energy performance

<b>Internal shading types</b>	<b>Cooling energy consumption (KWh)</b>	<b>Heating energy consumption (KWh)</b>	<b>Annual energy consumption (KWh)</b>
Drapes close weave	87458.08	75284.84	162742.92
Slatted blind high reflectivity	83561.29	74788.48	158349.77
Diffusing blind – shade roll	85617.48	75558.99	161176.47

As shown in table 9.15, the diffusing blind- shade roll which is used as an internal shading for the actual building design makes an annual energy consumption equal to 161176.17 KWh, while the use of slatted blind high reflectivity will lead to less energy consumption when compared to the other types of shading, making an annual energy consumption equal to 158349.77 KWh. This mean that, replacing diffusing blind shade roll with slatted blind high reflectivity will lead to annual energy saving equal to 2826.7 KWh.

In the second step, three types of external shading are simulated and their impacts on building energy performance are calculated. This is to find the best types to be used in the building design. The results are presented in table 9.16.

**Table 9.16.** The impact of external shading on building energy performance

<b>External shading types</b>	<b>Cooling energy consumption (KWh)</b>	<b>Heating energy consumption (KWh)</b>	<b>Annual energy consumption (KWh)</b>
No shading (actual)	87458.08	75284.84	162742.92
Overhang 0.5	81691.97	77299.54	158991.51
Fin 0.5	79114.93	80882.70	159997.63
0.5 overhang + 0.5 fin	73611.70	83033.68	156645.38

As shown in table 9.16, using both overhang and fin with projection (length) of 0.5 m will lead to less energy consumption when compared to the other shading types, making an annual energy consumption equal to 156645.28 KWh. Thus, adopting this type of shading in the building design will contribute to an annual energy saving equal to 9097.53 KWh. means that when using t when compared to the other. As we mentioned before, external shading is not used in the building.

Consequently, the simulation results of both internal and external shading confirm the established rule in which both slatted blind high reflectivity and the combination of overhang and fin with projection of 0.5 m should be used for building in Gaziantep-Turkey.

### **9.3. Optimum Design Decision- Best Practices**

In the previous section, various simulations were run for different design parameters to determine the impact of these design parameters and alternatives on building energy performance. Thus, in this section, the best combination of the simulated design parameters which was defined as the best design decision to be made for building are considered, and their impact on the building energy performance are calculated. This is to estimate the amount of energy that could be saved when adopting these design decisions in the early design stage and compare it with the actual design performance. The best practices regarding building design parameters are as follows:

- Building orientation: long length walls are facing south and north direction, and bigger glaze area are stored at the long walls facing south.
- Building form: rectangular building shape, and shape factor of 2.89
- Insulation: using extruded polystyrene (XPS) for both external wall and roof.
- External windows: triple-low e glazing (6mm)/16mm xenon gas
- External walls: the use of autoclaved concrete (AAC) block
- Window shading: the use of slatted blind high reflectivity for internal shading, and the use of (overhang +fin) with projection of 0.5 m for external shading.

The green roof is not considered in this case study because pitched roof is used to shade the building roof. This could be efficient, but it is not included in the design criteria as part of this study.

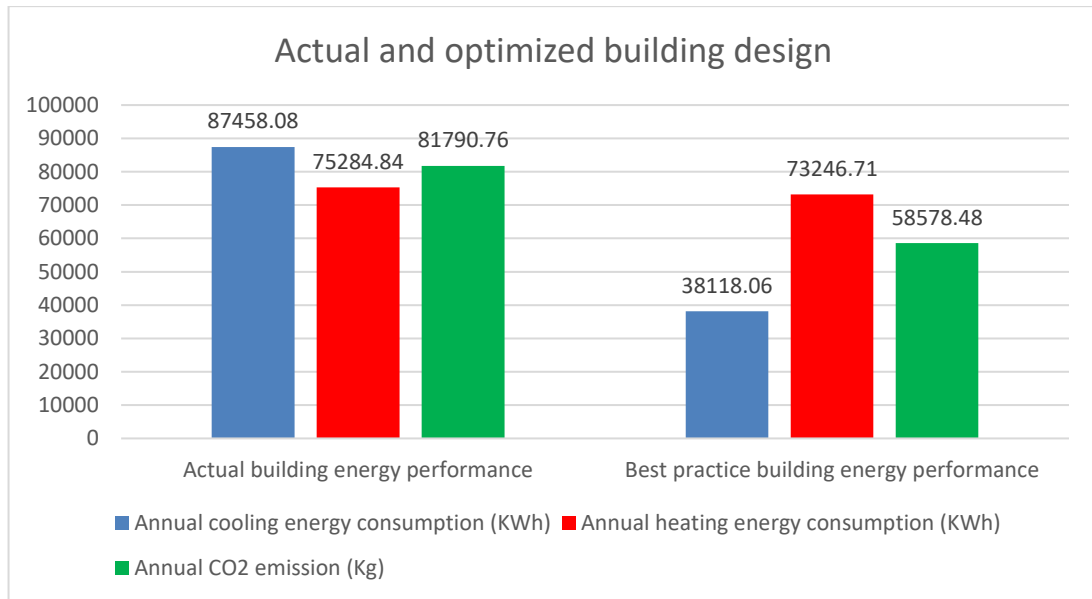

**Figure 9.5.** The actual and optimum design energy performance

As shown in figure 9.5, the best design decisions regarding building design parameters led to a significant energy saving when compared to the actual building design. The cooling energy consumption is decreased by 56% from 87458.08 KWh to 38118.06 KWh, the heating energy consumption is decreased by 3% from 75284.84 KWh to 73246.71 KWh, and finally the CO<sub>2</sub> emission is also reduced by 28% from 81790.76 Kg to 58578.48 Kg. As a result, the total amount of KWh that could be saved for both heating and cooling are equal to 51378.15 KWh for one year. To calculate the annual energy cost saving, the amount of energy saved for one year is multiplied by 0.2 \$. As a result, the annual energy cost saving is equal to 10275.63 \$ for one year.

Consequently, the results showed that adopting sustainable design strategies together with the established rules related building design parameters in the early design stage will greatly enhance and optimize the building design in term of energy performance and reduce the CO<sub>2</sub> emission, which in turn will create more environmentally and sustainable building design that could be easily and successfully implemented for buildings in Gaziantep-Turkey.

#### **9.4. Building Design Evaluation and Assessment**

In this section, the actual and optimized building design will be evaluated by using the local energy performance assessment scheme which is identified within the forth component of the framework. Along with the assessment scheme rating, this local energy scheme provides many information about the building's energy performance



recommendations to enhance building energy efficiency. It plays a key role in providing information about the actual energy performance level for any building design in the early design stage. Thus, determining how much the building is efficient in term of energy performance, and providing advices to upgrade the building design to reach better ratings as it contain measures for optimizing building design parameters.

To assess the energy performance of the building design, we will first use the evaluation scoring legend to grade each design parameters used in the building (see table 9.17). This scoring legend contain four success levels implementations of the rules-based design. Thus, based on the results and the ranks of the simulated parameters and their alternatives in term of energy performance, the level of success in implementing these rules will be determined. Accordingly, a number of points will be given to each one of them.

**Table 9.17.** The evaluation scoring scale legend

<b>Points (*)</b>	<b>Grades for the Implementation of Design Rules</b>
0	Not implemented
1	un successful implementation
2	Average successful implementation
3	Successful implementation

Once the level of success in implementing the design rules for each design parameter is determined, then the local energy assessment scheme will be used to calculate the overall performance of the building design. Table 9.16 present the local energy assessment scheme and the points given for the actual building design.

**Table 9.18.** The evaluation of the actual building design

<b>Local Energy Performance Assessment Scheme</b>							
	<b>Rules based building design</b>		<b>Points (*)</b>		<b>Rules based building design</b>		<b>Points (*)</b>
	<b>Energy conservation (EC)</b>	Orientation EC1	EC 1.1		1	<b>Material conservation (MC)</b>	Insulation (MC1)
EC 1.2			1	MC 1.2	0		
Building form (EC2)		EC 2.1	3	External window (MC2)	MC 2.1		2
		EC 2.2	2		MC 2.2		1
Green roof (EC3)		EC 3.1	3		MC 2.3		2
PV technology (EC4)		EC 4.1	2		MC 2.4		1
		EC 4.2	2		MC 2.5		2
		EC 4.3	3	External window (MC3)	MC 3.1		3
				Window shading (MC4)	MC 4.1		2
				MC 4.2	0		
<b>Total point achieved</b>			17	<b>Total point achieved</b>			15
<b>Section points</b>			24	<b>Section points</b>			30
<b>Success level %</b>			71	<b>Success level %</b>			50
<b>Total success = 60.5 %</b>							

As shown in table 9.18, for energy conservation criteria (EC), the required design methods are: effective direction of the building (EC1), use simple geometric design (EC2), green roof application (EC3), and proper use of PV technology (EC4).

In line to these methods, the rules EC 2.1, and EC 4.3 were implemented successfully, and then 3 points are awarded for each one. EC 2.2, EC 4.1, and EC 4.2, and EC were implemented with average success, accordingly 2 point are given to each one. EC 1.1 and EC 1.2 were poorly implemented; thus 1 points is given to each one. EC 2.2 refers to the shape factor and it should be equal to 2.89 while the shape factor of the actual building design is equal to 2.69. EC 4.1 refers to orientation of PV panels and it should be at south orientation while the orientation of the actual PV design is facing south-west orientation. EC 4.2 refers to the tilt angle of the PV panels, and it should be equal to 30, while the actual PV tilt angle is equal to 16. EC 1.1 and EC 1.2 refers to the building orientation, based on the simulation results the south orientation in which the long length wall facing north-south and bigger glaze area should be facing south

orientation is the best decision to make, while the actual building orientation is facing south-west orientation. Finally, EC 3 which refers to green roofing is not applied in the actual building. However, pitched roof is used to shade the roof. This could be efficient but it is not included in the design criteria and method as a part of this study, but three points are given to this method as pitched roof is being implemented

For material conservation criteria, the required methods are: choosing efficient insulation material (MC1), high performance window (MC2), efficient wall construction materials (MC3), and effective shading (MC4).

In line to these methods, MC 3.1 were implemented successfully, and then 3 points are awarded to this design method. MC 1.1, MC 2.1, MC 2.3, MC 2.5, and MC 4.1 were implemented with average success, and 2 points are awarded to each one. MC 2.2 and MC 2.4 were poorly implemented; accordingly, 1 point is awarded to each one. Finally, MC 1.2 and MC 4.2 are awarded no points because they are not implemented.

MC 1.1 refers to roof insulation, the type used for actual building roof is rock wool, and while the simulation results showed that extruded polystyrene (EXP) is the best type to be used. MC 2.1 refers to window system type, double glazing is used for the actual design, while the simulation results showed that triple glazing has the best performance. MC 2.3 refers to glazing thickness, 4mm glazing is used for the actual building, while the simulation results showed that 6mm perform the best in terms of energy performance. MC 2.5 refers to window gap thickness, 13 mm gap thickness is used for the actual window design, while the simulation results showed that window gap thickness of 16 mm perform the best in terms of energy performance. MC 4.1 refers to the internal shading, shade roll is used for the building, while the simulation results showed that slatted blind with high reflectivity is better to be used to shade windows. MC 2.4 refers to the gas infill type, the type used for the actual windows is air while the results of analysis shows that xenon is better to be used in window. Consequently, the actual building design is 71% successful in implementing the rules related energy conservation EC, and 50% successful in implementing the rules related materials conservation MC. As a result, the building is 60.5 % (good) successful on the basis of total points considering both energy and material conservation criteria.

Based on the analysis and simulation results, the implementation of design rules and ontologies will significantly lead to enhance the building energy performance. Thus, considering these rules in the early design stage is highly needed.

### **9.5. Suggestions to Optimize Building Energy Performance**

In the previous sections various simulations were conducted regarding building design parameters, different alternatives were also examined and analyzed and the best one in term of energy performance were selected as the best choice to be made for the building design. As a result, a couple of the best design decisions regarding design parameters including: building orientation, building form, PV technology, insulation materials, external windows, wall materials, and window shading were identified. These design decisions led to a great decrease in the total energy use in term of cooling and heating energy.

According to our framework and based on the findings from the simulation of the building design, we will present a few suggestions to optimize the building performance and make the building more environmental friendly, these are as follows:

- In terms of building design and morphology, the existing building has a rectangular design shape which is very good for energy efficiency. However, according to our findings, it would be better if the building has shape factor of 2.98. This represents the optimum proportion of the long length walls to short length walls. The shape factor plays a significant role in minimizing the exposed area of the building walls which in turn will lead to less heat losses of the building envelope which are exposed to the outside weather and environment.
- In term of building orientation, the actual building has an orientation of southwest. This could be somehow efficient, but according to our findings, orientation of south is the best choice to be made as it leads to less energy consumption especially in winter. Orienting the building in a way its long walls with bigger glaze area facing south will help the building to be naturally heated, and day lighted. Moreover, making the right orientation would be useful to make less investment in insulation.
- In term of wall material, gas concrete (AAC) block was used for the external walls of the building which is very good and efficient material in term of energy

efficiency. Our findings confirmed the use of this type of blocks for external wall as it works a good heat insulator for the building.

- In term of external window performance, the parameters affecting the total energy performance are window system, glass type and thickness, and the gas infill type and thickness. Each one of these parameters has an impact on the building energy consumption. The actual window used for the building is double glaze of 4mm transparent glass and 13 mm air infill gap. This could efficient in term of energy performance. But, based on our finding, there is an opportunity to enhance the window performance by using triple window system of 6 mm low-glass with 16mm xenon infill gas. These parameters will affect the (U-value) and (SHGC) significantly. As a result, will lead to minimize the U-value of window and limiting the amount of SHGC by the building. Reducing the U-value of windows will lead to less flow of energy from outside to inside and conversely which in turn will lead to less heat gain in summer time and less heat loss in winter time. While (SHGC) represent the amount of heat gained by the window. Based on the findings, it's necessary to consider the value of SHGC in the design decision of window.
- Insulation materials are also suggested to be considered in the building design. In the actual building rock wool was used for roof insulation while no insulation used for walls. Based on the findings, the type of insulation used is good and efficient. However, other insulation materials such as extruded polystyrene (XPS) has better impact on the total energy consumption. That's why this type is recommended to be used for both roofs and walls as it reduce the U value opaque building envelope. Thus, it keeps the building warm in winter, and prevent the heat to flow inside the building in summer.
- In term of PV technology, the type of PV used in the building is poly crystalline which is quite efficient and recommended to be used in building as highlighted in the literature. The orientation and tilt angle of PV modules play a significant role in the amount of energy generation. For the actual PV design the decision was made to place PV modules on the roof with orientation facing south-west and tilt angle of 16°. However, based on our findings, the energy generation of PV modules could be optimized by orientation the PV modules toward south. Moreover, to maximize the exposure of the modules, tilt angle of 30 will increase the efficiency as well as the energy generation of the PV modules.

- In term of window shading, there are two types of shading namely internal shading and external shading. It's known that shading play a vital role in decreasing the cooling energy need of building. Therefore, including such parameters in the design is highly recommended. Based on the findings the use of (overhang+fin90ssa) with length of 0.5 m for external shading will perform the best which lead to less energy consumption. Moreover, careful selection of internal shading is also critical in achieving less energy consumption. The use of slatted blind with high reflectivity has the best performance in term of efficiency. It greatly minimizes the unwanted heat to flow inside the building. Consequently, less cooling load will be required to cool the building in summer time.

In general, the application of these design strategies will enhance the building energy performance and will promise efficient design that makes the less energy consumption. Consequently, sustainable and environmental friendly design with less Co2 emission can be achieved.

## **9.6. Conclusion**

In this chapter, the overall BIM based design and optimization framework was validated on a real building case study. This was done in three stages, in the first stage the process of building design and analysis by using BIM was adopted to create the 3D building geometry and analyze the actual building energy performance. Then in the second stage, the actual building design is optimized by adopting the design rules and ontology related building design parameters and PV technology. Finally, by using the local energy performance evaluation both the actual and optimized building design is evaluated and assessed.

To check out the efficiency as well as the effectiveness of this framework, a university building case study is conducted in Gaziantep-Turkey. The result of the case study shows that the performance-based design framework can help to increase the searching space for the best design solutions and decrease the process time required for better design results, which can be help the designers and engineers to design a sustainable and environmental friendly building design. Considering all, the overall framework constitutes a useful design workflow, which aims to quantify the environmental

savings of the building design by utilizing, advanced computational analysis and common construction techniques.

Consequently, the results showed that the actual building is 54% efficient. However, adopting the developed design rules and ontology will lead to enhance the building performance significantly.



## CHAPTER 10

### CONCLUSION AND RECOMMENDATION

#### 10.1. Introduction

In this research, the energy performance of buildings together with design practices of buildings in Turkey were highlighted. It's shown that buildings in Turkey consume a great amount of energy and consequently a great amount of CO<sub>2</sub> is emitted to the atmosphere. This is due to the design practices which are not effective enough to achieve efficient building design in term of energy performance. Thus, the design parameter that impact the energy performance of building including, climate features and building location, building architecture and orientation, building envelope (walls, roofs, insulation, windows, shading), and renewable energy practices were comprehensively discussed and the previous studies regarding these issues were also reviewed. In these studies, BIM and different energy simulation tools were used and it showed that the use BIM and energy simulation tools promises a good and significant energy solutions to the building design.

Thus, a comprehensive review was made about BIM and energy simulation tool and its role in achieving efficient building design. Accordingly, a simulation system was specified to analyze a real building case study by simulating different design parameters and the results showed that there a need to identify a holistic design approach for performance-based design and optimization through integrated BIM use. As a focal point we developed a framework that incorporate four main components that consider sustainable design requirements.

The components within the developed framework then were identified through the application of multi case studies. As a result, with BIM based simulation the subcomponents and required tasks to achieve the main component within the conceptual framework were identified. Then, based on the response, a new framework which encapsulate all the main and subcomponent together with requirements and



tasks needed for the best implementation of the framework was develop. Finally, the new framework was tested on the building project for validation.

It is also important to mention that the research process was clearly explained by adopting the research onion developed by Saunders (et al, 2009). The various types of process involved are put and the best was chosen. Consequently, the research philosophy adopted was pragmatism, research approach was exploratory inductive approach, the research strategy was case study, the research choice was mixed method, and the time horizon was the cross-sectional method as mentioned with the relevant argument in chapter 4. The achievements of the objectives, contributions of the research to the knowledge, and the recommendations for future work are provided in the following sections.

## **10.2. Achievement of Objectives**

The main aim of this research was to develop a strategic BIM framework for the optimization of building design for energy efficient buildings in Turkey. To achieve this aim seven objectives were developed. During this research the following research objectives were achieved in full. The findings related to each objective are identified and discussed during this research and consequently the summary of the findings are as follows:

### **10.2.1. Objective 1**

To explore and identify the important aspects of building energy performance and the challenges and the current architectural trends in Turkey and to explain the components of building design that impacts the energy performance of buildings. This was achieved in the literature review in chapter 2, by giving a general explanation of the current energy use of buildings in global context and then this was narrowed to the current energy use of buildings in Turkey and identifying the current design practices and energy efficiency features of building in Turkey. In addition, a comprehensive review was done for the design components that impacts the building energy performance showing how these components can contribute to efficient building design in term of energy performance.

### **10.2.2. Objective 2**

To build better understanding about BIM and its implementation in the construction projects, highlighting its importance in achieving sustainable building design. This was also realized by reviewing the literature as seen in chapter 2 and chapter 3. In chapter 2 different studies employing BIM and different energy simulation tools to study the impact of building design components on energy performance were reviewed. In chapter 3 the use of BIM and its importance, its implementation in construction projects, and the role of BIM in ensuring sustainable building design and improving energy performance were comprehensively discussed.

### **10.2.3. Objective 3**

To examine the interoperability between BIM and energy simulation software and specify a simulation system for the analysis of building energy performance considering different design criteria. This was realized through the review of literature in chapter 3 by identifying the possible ways for BIM and energy software simulation integration. This was followed by identifying Revit architecture as a BIM tool covering its advantages and disadvantages and finally different energy simulation tools were reviewed. Thus, a simulation system was chosen and specified for the analysis of building energy performance of buildings, however the rationale and reasons for choosing the simulation system are identified under section 5.1 in chapter 5. Moreover, chapter 4 covered the methodology used to explain the research philosophy, research approach, research strategy, research choices adopted in this research and data collection in order understand the research process.

### **10.2.4. Objective 4**

To contextualize a performance-based design framework that takes into consideration of sustainable design requirements. Based literature reviewed in chapter 2 together with the simulation system identified chapter 3, a real case study building was conducted and analyzed carefully and the results of the analysis were used as basis for the conceptual BIM framework establishment in chapter 5. This conceptual framework included four main components namely a design and optimization process, technology implementation, building design rules and ontology, and energy assessment scheme reflecting local values and environment. A coherent representation of the thought

process for the hypothetical BIM implementation framework with reasons and discussion on the main components within the framework were also given.

#### **10.2.5. Objective 5**

Examine, analyze and compare the energy consumption of two different buildings in terms of varying design strategies adopting the established BIM framework. This was achieved through the analysis of two different buildings in chapter 6 and chapter 7. In chapter 6, a building case study were analyzed, and the energy performance of different design parameters were calculated and compared. Furthermore, based on the performance based design through integrated BIM use adopted for the analysis, the first main components of the framework which was a design and optimization process was identified. This was realized through the identification of the stakeholders involved in the design process, design process stages and tasks required by each stakeholder, and effective method for data and exchange requirements (see figure 6.18, and figure 6.19).

Then, for the same case study building the second main component which was technology implementation (PV technology) was also identified. This was achieved by exploring the steps required to successfully design a PV system by using design builder software and simulating the parameters-based performance optimization to achieve maximum energy generation of the designed PV system.

In chapter 7, another building case study was conducted and analyzed for identifying design rules and ontology, and local energy assessment scheme in which they represent the other two components of the established BIM framework. This was achieved by identifying the design methods and strategies required to achieve efficient energy building, then by considering these strategies together with design components highlighted in chapter 2, the building case study was analyzed, and the actual building energy performance and alternatives were calculated and compared. Consequently, the simulated design parameters were ranked from best to less impact on energy performance. Thus, rules which reflect the best design decision to be made were generated (see table 7.18).

Finally, a local energy assessment scheme was developed. This was achieved first by reviewing different schemes that globally used to understand their assessment

methods, scopes, performance criteria and credit scales. Then a scoring scale legend of four scoring levels was created (see table 7.19). Consequently, based on the generated rules and created scoring scale legend, a local energy performance assessment scheme reflecting local values was developed (see table 7.20).

#### **10.2.6. Objective 6**

Enhance the contextualized framework with the findings from the analysis of building design projects by detailing the process, technology, design rules and ontology, and finally the energy performance assessment scheme perspectives. This objective was achieved by identifying the subcomponents and their requirements to achieve each of the implemented main components of the framework. Then, a review was made for the implemented framework throughout the research. The results were a generic framework which encapsulate all the main and sub components of the framework together with the requirements and tasks needed for proper implementation of the framework. This overall framework is presented in a tabular form (please see table 8.4).

#### **10.2.7. Objective 7**

Validate the performance-based design framework employing BIM on building project and conclude the results with recommendations for the future studies. This objective was achieved by examining the effectiveness and efficiency of the framework on a university building case study in Gaziantep-Turkey. The results indicated that the performance based design can help to bring more optimal solutions and decrease the processing time for the optimal design results, which in turn this can help the designers to design a sustainable and environmentally friendly building design.

### **10.3. Contributions to the Knowledge**

This research presents an integrated and strategic BIM based design optimization guide that enables engineers and designers to search a larger design space more efficiently and provides them with an optimal set of solutions towards higher performance of buildings. Thus, this design guide will help designers to successful use of BIM for design optimization process, effective technology implementation, rules-based design development and energy assessment scheme reflecting local values for sustainable building design. This design guide identifies the components and tasks

necessary in the adoption of BIM (please see figure 8.4), the significance of various components and required tasks are explained in depth in chapter 8.

The main contributions of this research can be summarized as follows:

- 1- Changing the design process towards more accurate computation and optimization-based methods in which redefines the roles and responsibilities of design team and help them perform their tasks in a shorter time by adopting effective methods for data and information exchange and making them discover issues during the building design with substantial number of design alternatives very quickly.
- 2- Enabling designers to investigate important design criteria and helping them make informed design decisions and effective rules related to building design components including building orientation, envelope materials such as (walls, windows, insulation, and shading).
- 3- Providing the engineers an opportunity to ensure more efficient building design by adopting renewable energy practices such PV technology through integrated and comprehensive design process.
- 4- Providing the design team an opportunity to upgrade the building design using local energy assessment scheme as it provides recommendation and advices to upgrade the building design toward more energy efficient and environmentally friendly design.

#### **10.4. Main Conclusions from the Research**

The performance-based design and optimization of building design shows a great potential in achieving efficient and high-performance building design. Integrating a broader variety of simulations for different design parameters into the design process will lead to a more comprehensive examination of the solution space and provide better decision support for the designers. Thus, this research presented a holistic design approach for the performance-based design and optimization using both Revit architecture and design builder for the design and analysis of building energy performance. This design approach identifies the stakeholder involved, their roles and responsibilities, the main design aspects and efficient design strategies including

passive and active design strategies. The main conclusions from this research were as follows:

- Interoperability between BIM-based design and simulation tools can enhance the workflow between design documents and analysis applications, where data and information contained in the models can be used for analysis process as well.
- Both BIM design models and analysis model need to be properly developed and managed. There are considerations that must be taken in account to make sure that the produced building performance modeling is correct. These considerations are defining a thermal zone and specifying the upper limit of each zone or room in the building (see figure 6.3 and 6.4).
- Early collaboration between stakeholders during design process would greatly help in optimizing building design performance. This can be done by adopting and effective design process including the stakeholders involved and their responsibilities, and effective methods for data and information exchange.
- Energy requirements of buildings in Gaziantep-Turkey is greatly related to the design methods and strategies that have been implemented. Energy optimization are strongly needed.
- Building Orientation as a passive design strategy plays an important role in eliminating the building energy performance. Southern orientation is found to perform the best while eastern and western orientations perform worse.
- Building morphology plays a key role in achieving energy efficient building. Rectangular building form with shape factor of 2.89 is found to be the best decision for building shape design.
- In term of wall materials, the use of gas concrete (AAC) block has the best energy performance. Gas concrete is preferred to be used for walls as it preserves energy by providing heat insulation.
- The insulation of building envelopes has the greatest impact on the building energy performance. Extruded polystyrene is the best insulation material to be used for both walls and roofs.
- In term of external window, the thermal performance of windows can be determined by two factors, which are the thermal transmittance (U-value), and solar heat gain coefficient (SHGC). These factors determine the amount of heat

flow through a window. The window system including glazing layers, thickness, glaze type, gas infill type and thickness has an impact on the building energy performance. It is founded that triple window of 6mm low e glazing with 16mm of xenon gas infill type will perform the best in term of energy performance.

- Window shading including internal and external shading can reduce the cooling energy consumption. Also, green roof as an element of shading impact the cooling energy consumption greatly.
- The combination of design strategies will lead to significant energy saving. Implementing these design strategies in the early design stage will make around 50% energy saving in total energy consumption.

### **10.5. Recommendations for Future Work**

The wellbeing of future generation and protection of our environment depends on the careful use of energy sources. This can greatly be achieved by reducing the energy use through the optimization of building design. Respectively, it is necessary to design efficient building that lead to less energy consumption. This research showed that energy consumption could greatly be decreased by making effective decision during the early design stage. This can be done by using more efficient building materials and components for the buildings design. Moreover, much of the remaining energy used by occupant can be replaced the applying renewable technologies such as solar PV system. Therefore, it's necessary to:

- Encourage and motivate people for efficient building design. The simulation results of different design parameters showed a great optimization in term of heating and cooling energy consumption. This optimization can be done by Turkish institutions and municipalities regrading building orientation, envelope materials such as walls, windows, insulation, and shading with the use of simulation programs.
- The use of Solar PV system to supply the heating and cooling energy requirements are recommended. This system can greatly supply the building energy needs in Turkey.
- Energy saving measures should be considered as an investments, not as additional cost, and these investments should be considered as extra gain to the

budget of the building owner which in turn it will rise the value of the building, due to their environmental benefits.

- Investments in active measures leads to financial benefits after their payback period. This can be considered as a positive gain to the budget of the house occupants.
- Thermal transmittance values (U-values) of the building components which are identified in the Turkish standards should be reviewed and updated. To do that a new scientific method can be used, for example, the use of simulation programs such as design builder as explained in chapter 6.

This research has focused on developing a strategic performance based design and optimization framework for energy efficient building design in Turkey. Thus, it's recommended to employ this design approach in the all construction companies and organization as it promises sustainable and ecological design and improved energy performance building in Turkey. Moreover, the utilization of such framework in other places which have different environmental features could be another area for future research.

Finally, the created framework is easily expandable and customizable through the inclusion of more connected components or even new user-defined applications within the BIM environment, which could be utilized as a design tool to inform early stage, efficient building design solutions.



## REFERENCES

- Abanda, F. H., & Byers, L. (2016). An investigation of the impact of building orientation on energy consumption in a domestic building using emerging BIM (Building Information Modelling). *Energy*, 97, 517-527.
- Abdelhameed, W. (2017). Sustainable Design Approach: A case study of BIM use. In *E3S Web of Conferences* (Vol. 23, p. 02001). EDP Sciences.
- Abed, F. M., Al-Douri, Y., & Al-Shahery, G. M. (2014). Review on the energy and renewable energy status in Iraq: The outlooks. *Renewable and Sustainable Energy Reviews*, 39, 816-827.
- Abubakar, M., Ibrahim, Y. M., Kado, D., & Bala, K. (2014). Contractors' Perception of the Factors Affecting Building Information Modelling (BIM) Adoption in the Nigerian Construction Industry. In *Computing in Civil and Building Engineering* (2014) (pp. 167-178).
- Acosta, I., Campano, M. Á., & Molina, J. F. (2016). Window design in architecture: Analysis of energy savings for lighting and visual comfort in residential spaces. *Applied Energy*, 168, 493-506.
- Ahmed, A. N., Samaan, M. M., Farag, O. M., & El Aishy, A. S. (2011, November). Using simulation tools for enhancing residential buildings energy code in Egypt. In *12th Conference of International Building Performance Simulation Association, Sydney* (pp. 14-16).
- AJEEL, R. K., & YUSOF, I. M. Z. M. Using polystyrene foam to reduction the cooling load by Auto desk Revit software.
- Akadiri, P. O., Chinyio, E. A., & Olomolaiye, P. O. (2012). Design of a sustainable building: A conceptual framework for implementing sustainability in the building sector. *Buildings*, 2(2), 126-152.
- Aksamija, A. (2013). Building simulations and high-performance buildings research: use of building information modeling (BIM) for integrated design and analysis. *Perkins+ Will Res. J*, 5(01), 20-34.
- Aksamija, A., & Mallasi, Z. (2010). Building Performance Predictions: How Simulations Can Improve Design Decisions. *Perkins+ Will Research Journal*, 2(2), 7-32.
- Alaghbandrad, A. (2015). BIM maturity assessment and certification in construction project team selection (Doctoral dissertation, École de technologie supérieure).

- Aldali, K. M., & Moustafa, W. S. (2016). An attempt to achieve efficient energy design for High-Income Houses in Egypt: Case Study: Madenaty City. *International Journal of Sustainable Built Environment*, 5(2), 334-344.
- Al-Ghamdi, S. G., & Bilec, M. M. (2015). Life-cycle thinking and the LEED rating system: global perspective on building energy use and environmental impacts. *Environmental Science & Technology*, 49(7), 4048-4056.
- Ali, A. A., & Ahmed, T. M. (2012). Evaluating the impact of shading devices on the indoor thermal comfort of residential buildings in egypt. *Proceedings of SimBuild*, 5(1), 603-612.
- Ali, S. R., Mahdjoubi, L., Khan, A., & Sohail, F. A. A Comparative Study of ECOTECT, EngeryPlus & DAllux (Building Energy Lighting Simulation) tools.
- Almahmoud, E., & Doloi, H. K. (2015). Assessment of social sustainability in construction projects using social network analysis. *Facilities*, 33(3/4), 152-176.
- Alrikabi, N. K. M. A. (2014). Renewable energy types. *Journal of Clean Energy Technologies*, 2(1), 61-64.
- Altan, H., Hajibandeh, M., Aoul, K. A. T., & Deep, A. (2016). Passive Design. In *ZEMCH: Toward the Delivery of Zero Energy Mass Custom Homes* (pp. 209-236). Springer, Cham
- Anastas, P. T., & Zimmerman, J. B. (2003). Peer reviewed: design through the 12 principles of green engineering.
- Antonova, A. (2010). Passive house for Latvia. Energy efficiency and technical-economic aspects.
- Arayici, Y. (2015). *Building Information Modeling-eBooks and textbooks from bookboon.com*.
- Arayici, Y., Egbu, C. O., & Coates, S. P. (2012). Building information modelling (BIM) implementation and remote construction projects: issues, challenges, and critiques. *Journal of Information Technology in Construction*, 17, 75-92.
- Arkesteijn, K., & van Dijk, D. (2010). Energy performance certification for new and existing buildings. *EC Cense P*, 156.
- Ashcraft, H. W. (2008, June). Implementing BIM: A report from the field on issues and strategies. In Paper Presentation at the 47th Annual Meeting of Invited Attorneys.
- Attia, S. (2011). State of the art of existing early design simulation tools for net zero energy buildings: a comparison of ten tools. *Architecture et climat*.
- Auffhammer, M., & Mansur, E. T. (2014). Measuring climatic impacts on energy consumption: A review of the empirical literature. *Energy Economics*, 46, 522-530.

Ayyad, T. M. (2011). The Impact of Building Orientation, Opening to Wall Ratio, Aspect Ratio and Envelope Materials on Buildings Energy Consumption in the Tropics (Doctoral dissertation, The British University in Dubai (BUiD)).

Azhar, S. (2011). Building information modeling (BIM): Trends, benefits, risks, and challenges for the AEC industry. *Leadership and management in engineering*, 11(3), 241-252.

Azhar, S., Brown, J., & Farooqui, R. (2009, April). BIM-based sustainability analysis: An evaluation of building performance analysis software. In *Proceedings of the 45th ASC annual conference* (Vol. 1, No. 4, pp. 90-93).

Azhar, S., Carlton, W. A., Olsen, D., & Ahmad, I. (2011). Building information modeling for sustainable design and LEED® rating analysis. *Automation in construction*, 20(2), 217-224.

Azhar, S., Khalfan, M., & Maqsood, T. (2015). Building information modelling (BIM): now and beyond. *Construction Economics and Building*, 12(4), 15-28.

Azhar, S., Nadeem, A., Mok, J. Y., & Leung, B. H. (2008, August). Building Information Modeling (BIM): A new paradigm for visual interactive modeling and simulation for construction projects. In *Proc., First International Conference on Construction in Developing Countries* (Vol. 1, pp. 435-446).

Bahar, Y. N., Pere, C., Landrieu, J., & Nicolle, C. (2013). A thermal simulation tool for building and its interoperability through the building information modeling (BIM) platform. *Buildings*, 3(2), 380-398.

Bahar, Y.N., Pere, C., Landrieu, J. and Nicolle, C., 2013. A thermal simulation tool for building and its interoperability through the building information modeling (BIM) platform. *Buildings*, 3(2), pp.380-398.

Barista, D. (2012). Early BIM adopters are receiving a windfall of healthcare work. *Trimble Dimensions*.

Bauer, M., Mösele, P., & Schwarz, M. (2009). *Green building: guidebook for sustainable architecture*. Springer Science & Business Media.

Bekar, D. (2007). Examination of Active Energy Systems in Ecological Architecture (Doctoral dissertation, M. Sc. Thesis, Yıldız Technical University Institute of Science and Technology, Istanbul).

Bektas Ekici, B. (2015). Evaluation of TS 825 Thermal Insulation Requirements in Buildings in Turkey in Terms of Solar Radiation. *MEGARON*, 10(1), 14-24.

Bellia, L., Marino, C., Minichiello, F., & Pedace, A. (2014). An overview on solar shading systems for buildings. *Energy Procedia*, 62, 309-317.

Bilgiç, S. (2003). Passive solar design strategies for buildings: A case study on improvement of an existing residential building's thermal performance by passive solar design tools (Master's thesis, İzmir Institute of Technology).

- Bin Zakaria, Z., Mohamed Ali, N., Tarmizi Haron, A., Marshall-Ponting, A. J., & Abd Hamid, Z. (2013). Exploring the adoption of Building Information Modelling (BIM) in the Malaysian construction industry: A qualitative approach. *International Journal of Research in Engineering and Technology*, 2(8), 384-395.
- Biswas, K., Shrestha, S. S., Bhandari, M. S., & Desjarlais, A. O. (2016). Insulation materials for commercial buildings in North America: An assessment of lifetime energy and environmental impacts. *Energy and Buildings*, 112, 256-269.
- Biswas, T., & Tsung-Hsien Wang, R. K. (2008). Integrating sustainable building rating systems with building information models.
- Boeri, A., & Longo, D. (2010). Eco-technologies for energy efficient buildings in Italy. *WIT Transactions on Ecology and the Environment*, 128, 399-410.
- Bonenberg, W., & Wei, X. (2015). Green BIM in sustainable infrastructure. *Procedia Manufacturing*, 3, 1654-1659.
- Booth, J. (2013) Design your own framework, Jim Booth's website, [http://www.jamesbooth.com/designing\\_your\\_own\\_framework.htm](http://www.jamesbooth.com/designing_your_own_framework.htm).
- Butera, F. M. (2005, May). Glass architecture: is it sustainable. In International Conference "Passive and Low Energy Cooling for the Built Environment", Santorini, Greece (pp. 161-163).
- Belsky, M., Eastman, C., Sacks, R., Venugopal, M., Aram, S., & Yang, D. (2014). for precast concrete building models. *PCI Journal*.
- Bynum, P., Issa, R. R., & Olbina, S. (2012). Building information modeling in support of sustainable design and construction. *Journal of Construction Engineering and Management*, 139(1), 24-34.
- Cable, V., Fallon, M., & Higgins, D. (2013). *Construction 2025*. HM Government: London, UK, 80.
- Cao, X., Dai, X., & Liu, J. (2016). Building energy-consumption status worldwide and the state-of-the-art technologies for zero-energy buildings during the past decade. *Energy and buildings*, 128, 198-213.
- Capeluto, I. G., & Ochoa, C. E. (2014). Simulation-based method to determine climatic energy strategies of an adaptable building retrofit façade system. *Energy*, 76, 375-384.
- Çerçi, s. (2014). Climate responsive residential building design in turkey-a case study.
- Chan, C. T. (2014). Barriers of implementing BIM in construction industry from the designers' perspective: a Hong Kong experience. *Journal of System and Management Sciences*, 4(2), 24-40.
- Charron, R., & Athienitis, A. (2006). Design and Optimization of Net Zero Energy Solar Homes. *ASHRAE transactions*, 112(2).

Chen, D., & Gehrig, B. (2011). Implementing Building Information Modeling in Construction Engineering Curricula. In American Society for Engineering Education. American Society for Engineering Education.

Cho, C.S., Chen, D. and Woo, S., 2012. Building information modeling (BIM)-Based design of energy efficient buildings. *Journal of KIBIM*, 2(1), pp.1-6.

Chwieduk, D. A. (2016). Some aspects of energy efficient building envelope in high latitude countries. *Solar Energy*, 133, 194-206.

CIBSE, G. F. (2004). Energy efficiency in buildings. Chartered Institution of Building Services Engineers.

Collis, J., & Hussey, R. (2014). *Business Research-a practical guide for undergraduate and postgraduate students*: Palgrave Macmillan Higher Education.

Council, C. R. (2011). Sustainable tropical building design: guidelines for commercial buildings. Cairns, Queensland, Australia: Cairns Regional Council.

Crawford, R. H., Bartak, E. L., Stephan, A., & Jensen, C. A. (2016). Evaluating the life cycle energy benefits of energy efficiency regulations for buildings. *Renewable and Sustainable Energy Reviews*, 63, 435-451.

Crawley, D. B., Lawrie, L. K., Winkelmann, F. C., Buhl, W. F., Huang, Y. J., Pedersen, C. O., ... & Glazer, J. (2001). EnergyPlus: creating a new-generation building energy simulation program. *Energy and buildings*, 33(4), 319-331.

Crawley, D., Winkelmann, F., Lawrie, L., & Pedersen, C. (2001). EnergyPlus: a new-generation building energy simulation program. In FORUM-PROCEEDINGS- (pp. 575-580). AMERICAN SOLAR ENERGY SOC & THE AMERICAN INSTITUTE OF ARCHITECTS.

Creswell, J. W. (2007). *Research design: Qualitative, quantitative, and mixed methods approaches*. Sage. Publications, inc.

Creswell, J. W. (2014). *A concise introduction to mixed methods research*. Sage Publications.

Cumpton, L. (2010, April 7). Revitology: The Evolution of Revit over AutoCAD. Retrieved from Architectural Evangelist: <http://www.architecturevangelist.com>

Czmoch, I., & Pękala, A. (2014). Traditional design versus BIM based design. *Procedia Engineering*, 91, 210-215.

De Boeck, L., Verbeke, S., Audenaert, A., & De Mesmaeker, L. (2015). Improving the energy performance of residential buildings: A literature review. *Renewable and Sustainable Energy Reviews*, 52, 960-975.

Denscombe, M. (2005). Research ethics and the governance of research projects: the potential of internet home pages. *Sociological Research Online*, 10(3), 1-10.

Diao, Y., Kato, S., & Hiyama, K. (2011, December). Development of an optimal design aid system based on building information modeling. In *Building simulation* (Vol. 4, No. 4, pp. 315-320). Tsinghua Press.

Dikmen, N. (2011). Performance analysis of the external wall thermal insulation systems applied in residences. *Of Thermal Science and Technology*, 31, 67-76.

Dos Santos, Í. P., & Rüther, R. (2012). The potential of building-integrated (BIPV) and building-applied photovoltaics (BAPV) in single-family, urban residences at low latitudes in Brazil. *Energy and Buildings*, 50, 290-297.

Douglass, C. D. (2011). *Instructional Modules Demonstrating Building Energy Analysis Using a Building Information Model*.

Dowsett, R. M., & Harty, C. F. (2013, September). EVALUATING THE BENEFITS OF BIM FOR SUSTAINABLE DESIGN—A REVIEW. In *Proceedings 29th Annual ARCOM Conference* (pp. 2-4).

Eadie, R., Odeyinka, H., Browne, M., McKeown, C., & Yohanis, M. (2014). Building information modelling adoption: an analysis of the barriers to implementation. *Journal of Engineering and Architecture*, 2(1), 77-101.

East, W. E., & Brodt, W. (2007). BIM for construction handover. *Journal of Building Information Modeling*, 2007, 28-35.

Easterby-Smith, M., Thorpe, R., & Jackson, P. (2012). *Management Research*, 4th eds.

Eastman, C.M., Eastman, C., Teicholz, P. and Sacks, R., 2011. *BIM handbook: A guide to building information modeling for owners, managers, designers, engineers and contractors*. John Wiley & Sons.

Erten, D. (2012). The Beta Version of National Certification System is ready. *Bulletin of Ekoyapı—Ecological Buildings and Settlements*, 76-79.

Esiyok, U. (2007). Energy consumption and thermal performance of typical residential buildings in Turkey.

Eskandari, H., Saedvandi, M., & Mahdavinejad, M. (2017). The Impact of External Shading Design on the Building Energy Consumption.

Eskin, N., & Türkmen, H. (2008). Analysis of annual heating and cooling energy requirements for office buildings in different climates in Turkey. *Energy and Buildings*, 40(5), 763-773.

Freire, R. Z., Abadie, M., & Mendes, N. (2010, December). Numerical Simulation of Building-Integrated Photovoltaic Systems. In *Proceedings of the 13th Brazilian Congress of Thermal Sciences and Engineering (ENCIT 2010)*.

Froese, T. M. (2010). The impact of emerging information technology on project management for construction. *Automation in construction*, 19(5), 531-538.

- Gerber, D. J., Becerik-Gerber, B., & Kunz, A. (2010). Building information modeling and lean construction: Technology, methodology and advances from practice. In Proc. 18th Int'l Group for Lean Const.
- Gibbs, D., & O'Neill, K. (2014). The green economy, sustainability transitions and transition regions: a case study of Boston. *Geografiska Annaler: Series B, Human Geography*, 96(3), 201-216.
- Goia, F., Time, B., & Gustavsen, A. (2015). Impact of opaque building envelope configuration on the heating and cooling energy need of a single-family house in cold climates. *Energy Procedia*, 78, 2626-2631.
- Gong, X., Nie, Z., Wang, Z., Cui, S., Gao, F., & Zuo, T. (2012). Life cycle energy consumption and carbon dioxide emission of residential building designs in Beijing. *Journal of Industrial Ecology*, 16(4), 576-587.
- Gray, D. E. (2013). *Doing research in the real world*. Sage.
- Green Building Council Australia (GBCA) website, <https://new.gbca.org.au/green-star/rating-system/>.
- Gultekin, A. B., & Alparlan, B. (2011). Ecological Building Design Criteria: A Case Study in Ankara. *Gazi University Journal of Science*, 24(3), 605-616.
- Gültekin, A. B., & Ersöz, B. A. (2013). Ecological building design and evaluation in Ankara. *Građevinar*, 65(11.), 1003-1013.
- Gültekin, A. B., & Yavaşbatmaz, S. (2013). Sustainable design of tall buildings. *Građevinar*, 65(05.), 449-461.
- Guo, S. J., & Wei, T. (2016). Cost-effective energy saving measures based on BIM technology: Case study at National Taiwan University. *Energy and Buildings*, 127, 433-441.
- Gür, V. (2007). *A Design Support tool for Variable Building Skins in the scope of Sustainable Architecture (Doctoral dissertation, Ph. D Thesis, Istanbul Technical University Institute of Science and Technology)*.
- Gurung, A., Ghimeray, A. K., & Hassan, S. H. (2012). The prospects of renewable energy technologies for rural electrification: A review from Nepal. *Energy Policy*, 40, 374-380.
- Halder, V. (2008). *Upgrading a Broad Area Illuminating Integrating Sphere and Solar Transmittance Measurement of a Sheer Blind (Master's thesis, University of Waterloo)*.
- Ham, Y. and Golparvar-Fard, M., 2015. Mapping actual thermal properties to building elements in gbXML-based BIM for reliable building energy performance modeling. *Automation in Construction*, 49, pp.214-224.

- Han, Y., & Taylor, J. E. (2016). Simulating the Inter-Building Effect on energy consumption from embedding phase change materials in building envelopes. *Sustainable Cities and Society*, 27, 287-295.
- Hanna, G. B. (2013). Sustainable Energy Potential in the Egyptian Residential Sector. *Journal of Environmental Science and Engineering*. B, 2(6B), 374.
- Hardin, B. (2009). *BIM and Construction Management: Proven Tools, Methods, and Workflows*, 7.
- Harish, V. S. K. V., & Kumar, A. (2016). A review on modeling and simulation of building energy systems. *Renewable and Sustainable Energy Reviews*, 56, 1272-1292.
- Harmathy, N., Magyar, Z., & Folić, R. (2016). Multi-criterion optimization of building envelope in the function of indoor illumination quality towards overall energy performance improvement. *Energy*, 114, 302-317.
- Hartmann, T., Van Meerveld, H., Vosseveld, N., & Adriaanse, A. (2012). Aligning building information model tools and construction management methods. *Automation in construction*, 22, 605-613.
- Harvey, L. D. (2007). Net climatic impact of solid foam insulation produced with halocarbon and non-halocarbon blowing agents. *Building and Environment*, 42(8), 2860-2879.
- Hassan, J. S., Zin, R. M., Majid, M. A., Balubaid, S., & Hainin, M. R. (2014). Building energy consumption in Malaysia: An overview. *J. Teknol*, 70, 33-38.
- Hergunsel, M. F. (2011). Benefits of building information modeling for construction managers and BIM based scheduling.
- Hetherington, R., Laney, R., & Peake, S. (2010, July). Zero and low carbon buildings: A driver for change in working practices and the use of computer modelling and visualization. In *Information Visualisation (IV)*, 2010 14th International Conference (pp. 590-596). IEEE.
- Higgs, S., & Stokes, D. Z. (2008). BIM: It's not all just hype. *Healthcare Design*.
- Ilter, D. E. N. I. Z., & Ilter, A. T. (2011, June). An overview of green building practice in Turkey. In *Management and Innovation for a Sustainable Built Environment MISBE 2011*, Amsterdam, The Netherlands, June 20-23, 2011. CIB, Working Commissions W55, W65, W89, W112; ENHR and AESP.
- Inglesi-Lotz, R. (2013). The impact of renewable energy consumption to economic welfare: a panel data application. University of Pretoria.
- Jalaei, F., & Jrade, A. (2014). Integrating building information modeling (BIM) and energy analysis tools with green building certification system to conceptually design sustainable buildings. *Journal of Information Technology in Construction*, 19, 494.
- James, T., Goodrich, A., Woodhouse, M., Margolis, R., & Ong, S. (2011). Building-Integrated Photovoltaics (BIPV) in the residential sector: an analysis of installed



rooftop system prices (No. NREL/TP-6A20-53103). National Renewable Energy Lab.(NREL), Golden, CO (United States).

Jayamaha, L. (2006). *Energy-Efficient Building Systems: Green Strategies for Operation and Maintenance: Green Strategies for Operation and Maintenance*. McGraw Hill Professional.

Jeong, K. S., Lee, K. W., & Lim, H. K. (2010). Risk assessment on hazards for decommissioning safety of a nuclear facility. *Annals of Nuclear Energy*, 37(12), 1751-1762.

Jeong, W., & Kim, K. H. (2016). A Performance Evaluation of the BIM-Based Object-Oriented Physical Modeling Technique for Building Thermal Simulations: A Comparative Case Study. *Sustainability*, 8(7), 648.

Judkoff, R. (2008). Increasing building energy efficiency through advances in materials. *MRS bulletin*, 33(4), 449-454.

Karasu, A. (2010). *Concepts for Energy Savings in the Housing Sector of Bodrum, Turkey: Computer based analysis and development of future settlements using renewable energy*. Univerlagtuberlin.

Kazanasmaz, T., Uygun, I.E., Akkurt, G.G., Turhan, C. and Ekmen, K.E., 2014. On the relation between architectural considerations and heating energy performance of Turkish residential buildings in Izmir. *Energy and Buildings*, 72, pp.38-50.

Kazem, H. A., & Chaichan, M. T. (2012). Status and future prospects of renewable energy in Iraq. *Renewable and Sustainable Energy Reviews*, 16(8), 6007-6012.

Kensek, K.M., 2014. *Building information modeling*. Routledge.

Kilpatrick, R. A., & Banfill, P. F. (2011, November). Energy consumption in non-domestic buildings: A review of schools. In *World Renewable Energy Congress-Sweden; 8-13 May; 2011; Linköping; Sweden* (No. 057, pp. 1008-1015). Linköping University Electronic Press.

Kim, G., Lim, H. S., Lim, T. S., Schaefer, L., & Kim, J. T. (2012). Comparative advantage of an exterior shading device in thermal performance for residential buildings. *Energy and buildings*, 46, 105-111.

Kim, J. J., & Moon, J. W. (2009, July). Impact of insulation on building energy consumption. In *Building Simulation* (Vol. 2009, pp. 674-680).

Kim, S., & Woo, J. H. (2011, December). Analysis of the differences in energy simulation results between building information modeling (BIM)-based simulation method and the detailed simulation method. In *Proceedings of the Winter Simulation Conference* (pp. 3550-3561). Winter Simulation Conference.

Koenigsberger, I., & Ingersoll, T. G. (1974). *Mayhew. Szokolay Manual of Tropical Housing and Building* Longman, London.

Konstantinou, T., & Knaack, U. (2013). An approach to integrate energy efficiency upgrade into refurbishment design process, applied in two case-study buildings in Northern European climate. *Energy and Buildings*, 59, 301-309.

Krygiel, E., & Nies, B. (2008). *Green BIM: successful sustainable design with building information modeling*. John Wiley & Sons.

Kumar, S. (2008). *Interoperability between building information models (BIM) and energy analysis programs*. University of Southern California.

Kurul, E., Abanda, H., Tah, J.H. and Cheung, F., 2013, May. Rethinking the build process for BIM adoption. In *CIB World Building Congress Construction and Society*. Australia.

Lagüela, S., Díaz-Vilariño, L., Armesto, J. and Arias, P., 2014. Non-destructive approach for the generation and thermal characterization of an as-built BIM. *Construction and Building Materials*, 51, pp.55-61.

Latha, P. K., Darshana, Y., & Venugopal, V. (2015). Role of building material in thermal comfort in tropical climates—A review. *Journal of Building Engineering*, 3, 104-113.

Latiffi, A. A., Mohd, S., Kasim, N., & Fathi, M. S. (2013). Building information modeling (BIM) application in Malaysian construction industry. *International Journal of Construction Engineering and Management*, 2(A), 1-6.

Lawania, K. K., & Biswas, W. K. (2016). Achieving environmentally friendly building envelope for Western Australia's housing sector: A life cycle assessment approach. *International Journal of Sustainable Built Environment*, 5(2), 210-224.

Lee, W. L., & Burnett, J. (2008). Benchmarking energy use assessment of HK-BEAM, BREEAM and LEED. *Building and Environment*, 43(11), 1882-1891.

Li, N., Kwak, J. Y., Becerik-Gerber, B., & Tambe, M. (2013). Predicting HVAC energy consumption in commercial buildings using multiagent systems. In *Proceedings of the 30th International Symposium on Automation and Robotics in Construction and Mining, ISARC*.

Li, Z. (2006). A new life cycle impact assessment approach for buildings. *Building and Environment*, 41(10), 1414-1422.

Lim, Y. W. (2015). Building information modeling for indoor environmental performance analysis. *American Journal of Environmental Sciences*, 11(2), 55.

Liu, Z. G., Liu, J. Y., & Wang, S. S. (2013). Analysis of Factors Affecting Energy Consumption by Civil Buildings in China's Urban Areas. *International Journal of Energy Science*, 3(3).

Loutzenhiser, P. G., Maxwell, G. M., & Manz, H. (2007). An empirical validation of the daylighting algorithms and associated interactions in building energy simulation programs using various shading devices and windows. *Energy*, 32(10), 1855-1870.

- Lu, W., Fung, A., Peng, Y., Liang, C., & Rowlinson, S. (2014). Cost-benefit analysis of Building Information Modeling implementation in building projects through demystification of time-effort distribution curves. *Building and environment*, 82, 317-327.
- Maçka, S., & YASAR, Y. (2011). The Effects of Window Alternatives on Energy Efficiency and Building Economy in High-Rise Residential Buildings in Cold Climates. *Gazi University Journal of Science*, 24(4), 927-944.
- Maliene, V., & Malys, N. (2009). High-quality housing—A key issue in delivering sustainable communities. *Building and Environment*, 44(2), 426-430.
- Mangan, S. D., & Oral, G. K. (2016). Energy and Cost Analyses of Solar Photovoltaic (PV) Microgeneration Systems for Different Climate Zones of Turkey. *Energy and Power Engineering*, 8(03), 117.
- Mendler, S., & Odell, W. (2000). *The HOK guidebook to sustainable design*. John Wiley & Sons.
- Mirnoori, S. V. (2013). *Integration between Building Information Modeling (BIM) and Energy Performance Modeling to Analyze the Effects of Building Shape and Orientation on Energy Consumption* (Doctoral dissertation, Eastern Mediterranean University (EMU)-Doğu Akdeniz Üniversitesi (DAÜ)).
- Mirrahimi, S., Mohamed, M. F., Haw, L. C., Ibrahim, N. L. N., Yusoff, W. F. M., & Aflaki, A. (2016). The effect of building envelope on the thermal comfort and energy saving for high-rise buildings in hot-humid climate. *Renewable and Sustainable Energy Reviews*, 53, 1508-1519.
- Moakher, E. P. E., & Pimplikar, S. S. (2012). Building information modeling (BIM) and sustainability—using design technology in energy efficient modeling. *IOSR Journal of Mechanical and Civil Engineering*, 1(2), 10-21.
- Moon, H. J., Choi, M. S., Kim, S. K., & Ryu, S. H. (2011, November). Case studies for the evaluation of interoperability between a BIM based architectural model and building performance analysis programs. In *Proceedings of 12th Conference of International Building Performance Simulation Association* (Vol. 2011).
- Morrissey, J., Moore, T. and Horne, R.E., 2011. Affordable passive solar design in a temperate climate: An experiment in residential building orientation. *Renewable Energy*, 36(2), pp.568-577.
- Moselle, B. (2011, May). Why support renewables. In *Presentation at Electricity Policy Research Group Research Seminar* Spring, Cambridge UK.
- Muhaisen, A. S., & Daboor, H. R. (2013). Studying the Impact of Orientation, Size, and Glass Material of Windows on Heating and Cooling Energy Demand of the Gaza Strip Buildings. *J. Archit. Plan*, 27, 1-15.
- Nanajkar, A., & Gao, Z. (2014). BIM Implementation Practices at India's AEC Firms. In *ICCREM 2014: Smart Construction and Management in the Context of New Technology* (pp. 134-139).

Omran, H., & Marsono, A. K. (2016). Optimization of building energy performance through passive design strategies. *British Journal of Applied Science & Technology*, 13(6), 1-16.

Omran, H., Ghaffarianhoseini, A., Ghaffarianhoseini, A., Raahemifar, K., & Tookey, J. (2016). Application of passive wall systems for improving the energy efficiency in buildings: A comprehensive review. *Renewable and sustainable energy reviews*, 62, 1252-1269.

Oni, J. O., & Bolaji, B. O. (2011). Development of a universal DC power supply using solar photovoltaic, utility and battery power sources. *Journal of Energy in Southern Africa*, 22(1), 12-17.

Ordones, M., Marinoski, D. L., Braun, P., & R  ther, R. (2007). The impact of building-integrated photovoltaics on the energy demand of multi-family dwellings in Brazil. *Energy and Buildings*, 39(6), 629-642.

Oti, A. H., & Tizani, W. (2015). BIM extension for the sustainability appraisal of conceptual steel design. *Advanced Engineering Informatics*, 29(1), 28-46.

Pacheco, R., Ord  nez, J., & Mart  nez, G. (2012). Energy efficient design of building: A review. *Renewable and Sustainable Energy Reviews*, 16(6), 3559-3573.

Peng, C., Huang, Y., & Wu, Z. (2011). Building-integrated photovoltaics (BIPV) in architectural design in China. *Energy and Buildings*, 43(12), 3592-3598.

P  rez-Lombard, L., Ortiz, J., & Pout, C. (2008). A review on buildings energy consumption information. *Energy and buildings*, 40(3), 394-398.

Radwan, A. F., Hanafy, A. A., Elhelw, M., & El-Sayed, A. E. H. A. (2016). Retrofitting of existing buildings to achieve better energy-efficiency in commercial building case study: Hospital in Egypt. *Alexandria Engineering Journal*, 55(4), 3061-3071.

Rajendran, P., Seow, T., & Goh, K. C. (2012). Application of BIM for managing sustainable construction.

Raji, B., Tenpierik, M. J., & van den Dobbelsteen, A. (2016). An assessment of energy-saving solutions for the envelope design of high-rise buildings in temperate climates: A case study in the Netherlands. *Energy and Buildings*, 124, 210-221.

Reeves, T., Olbina, S., & Issa, R. R. (2015). Guidelines for using Building Information Modeling for energy analysis of buildings. *Buildings*, 5(4), 1361-1388.

Rezaei, R., Chiew, T.K., Lee, S.P. and Aliee, Z.S., 2014. Interoperability evaluation models: A systematic review. *Computers in Industry*, 65(1), pp.1-23.

Ritter, F., Geyer, P., & Borrmann, A. (2015, October). Simulation-based decision-making in early design stages. In 32nd CIB W78 Conference, Eindhoven, The Netherlands (pp. 27-29).

Robson, C. (2011). *Real world research* 3rd Ed. UK: Wiley.

Roderick, Y., McEwan, D., Wheatley, C., & Alonso, C. (2008). A comparative study of building energy performance assessment between LEED, BREEAM and Green Star schemes, Integrated Environmental Solutions Limited, Kelvin Campus, West of Scotland Science Park, Glasgow, G20 0SP, UK.

Rowlinson, S., Collins, R., Tuuli, M. M., & Jia, Y. (2010, May). Implementation of building information modeling (BIM) in construction: A comparative case study. In AIP Conference Proceedings (Vol. 1233, No. 1, pp. 572-577). AIP.

Ryan, E. M., & Sanquist, T. F. (2012). Validation of building energy modeling tools under idealized and realistic conditions. *Energy and Buildings*, 47, 375-382.

Saadatian, S. S., Freire, F., & Simões, N. Comparative Life-Cycle Analysis of Insulation Materials in a Dwelling, Addressing Alternative Heating Systems and Life Spans. *EPS*, 40, 1-00.

Sadineni, S. B., Madala, S., & Boehm, R. F. (2011). Passive building energy savings: A review of building envelope components. *Renewable and Sustainable Energy Reviews*, 15(8), 3617-3631.

Salihi, I. U. (2016). Application of structural building information modeling (S-BIM) for sustainable buildings design and waste reduction: a review. *International Journal of Applied Engineering Research*, 11(2), 1523-1532.

Samuel, E. I., & Joseph-Akwara, E. Responding to Building Energy Analysis And Performance With Building Information Model (BIM).

Sangeli, F. A., Majidi, M. J., Borzui, A., & Daryae, Z. (2014). Managing and optimization of energy consumption and offering strategies to materialize It. *European Online Journal of Natural and Social Sciences*, 3(3 (s)), 57.

Sarkar, A., & Bose, S. (2015). Thermal performance design criteria for bio-climatic architecture in Himachal Pradesh. *Current Science*, 109(9), 10.

Sarkar, A., & Bose, S. (2016). Exploring impact of opaque building envelope components on thermal and energy performance of houses in lower western Himalayans for optimal selection. *Journal of Building Engineering*, 7, 170-182.

Sassi, P. (2006). *Strategies for sustainable architecture*. Taylor & Francis.

Sassi, P. (2016). Built Environment Sustainability and Quality of Life (BESQoL) Assessment Methodology. In *Engaging stakeholders in education for sustainable development at university level* (pp. 21-32). Springer, Cham.

Saunders, M., Lewis, P., & Thornhill, A. (2007). Formulating the research design. *Research methods for business students*, 130-161.

Saunders, M., Lewis, P., & Thornhill, A. (2009). *for Business Students Fi Fth Edition*.

Sayın, S. (2006). Yenilenebilir enerjinin ülkemiz yapı sektöründe kullanımının önemi ve yapılarda güneş enerjisinden yararlanma olanakları (Doctoral dissertation, Selçuk Üniversitesi Fen Bilimleri Enstitüsü).

Sebastian, R., Haak, W., & Vos, E. (2009, November). BIM application for integrated design and engineering in small-scale housing development: a pilot project in The Netherlands. In International symposium CIB-W096 future trends in architectural management (pp. 2-3).

Seppänen, O., & Seppänen, M. (1996). Rakennusten sisäilmasto ja LVI-tekniikka. Sisäilmayhdistys.

Shakeel, S. R., Takala, J., & Shakeel, W. (2016). Renewable energy sources in power generation in Pakistan. *Renewable and Sustainable Energy Reviews*, 64, 421-434.

Sharma, S. K. (2013). Zero energy building envelope components: a review. *Int J Eng Res Appl*, 3(2), 662-675.

Sheth, A. Z. (2011). A refurbishment framework with an emphasis on energy consumption of existing healthcare facilities (Doctoral dissertation, © Amey Z. Sheth).

Sheth, A. Z., & Malsane, S. M. (2014). Building information modelling, a tool for green built environment.

Sisman, N., Kahya, E., Aras, N., & Aras, H. (2007). Determination of optimum insulation thicknesses of the external walls and roof (ceiling) for Turkey's different degree-day regions. *Energy Policy*, 35(10), 5151-5155.

Skopek, J. (2013). Factors Affecting Building Performance.

Smith, D. (2007). An Introduction to Building Information Modeling (BIM) | *Journal of Building Information Modelling*.

Sokolov, I. and Crosby, J., 2011. Utilizing gbXML with AECOSim Building Designer and speedikon.

Soltani, S. (2016). The Contributions of Building Information Modelling to Sustainable Construction. *World Journal of Engineering and Technology*, 4(02), 193.

Song, X., Ye, C., Li, H., Wang, X., & Ma, W. (2017). Field study on energy economic assessment of office buildings envelope retrofitting in southern China. *Sustainable cities and society*, 28, 154-161.

Sousa, J. (2012, September). Energy simulation software for buildings: review and comparison. In International Workshop on Information Technology for Energy Applications-IT4Energy, Lisbon.

Stake, R. E. (1995). *The art of case study research*. Sage.

Sulaiman, J., Azman, A., & Saboori, B. (2013). The potential of renewable energy: using the environmental Kuznets curve model. *American Journal of Environmental Sciences*, 9(2), 103.

Tabesh, T., & Begum, S. (2015). An investigation on energy efficient courtyard design criteria. In International Conference on Chemical, Civil and Environmental Engineering.

Tao, R., & Tam, C. M. (2013). System reliability theory based multiple-objective optimization model for construction projects. *Automation in Construction*, 31, 54-64.

Tauš, P., Taušová, M., Šlosár, D., Jeňo, M., & Koščo, J. (2015). Optimization of energy consumption and cost effectiveness of modular buildings by using renewable energy sources. *Acta Montanistica Slovaca*, 20(3).

Urbikain, M. K., & Sala, J. M. (2009). Analysis of different models to estimate energy savings related to windows in residential buildings. *Energy and Buildings*, 41(6), 687-695.

Uygunoğlu, T., Özgüven, S., & Çalış, M. (2016). Effect of plaster thickness on performance of external thermal insulation cladding systems (ETICS) in buildings. *Construction and Building Materials*, 122, 496-504.

Vera, S., Pinto, C., Victorero, F., Bustamante, W., Bonilla, C., Gironás, J., & Rojas, V. (2015). Influence of plant and substrate characteristics of vegetated roofs on a supermarket energy performance located in a semiarid climate. *Energy Procedia*, 78, 1171-1176.

Waddicor, D. A., Fuentes, E., Sisó, L., Salom, J., Favre, B., Jiménez, C., & Azar, M. (2016). Climate change and building ageing impact on building energy performance and mitigation measures application: A case study in Turin, northern Italy. *Building and Environment*, 102, 13-25.

Wong, A. K. D., Wong, F. K., & Nadeem, A. (2009, October). Comparative roles of major stakeholders for the implementation of BIM in various countries. In *Proceedings of the International Conference on Changing Roles: New Roles, New Challenges*, Noordwijk Aan Zee, The Netherlands (pp. 5-9).

Wong, J., Wang, X., Li, H., Chan, G., & Li, H. (2014). A review of cloud-based BIM technology in the construction sector. *Journal of Information Technology in Construction (ITcon)*, 19(16), 281-291.

Wong, K. D., & Fan, Q. (2013). Building information modelling (BIM) for sustainable building design. *Facilities*, 31(3/4), 138-157.

Yassine, F., & Abu-Hijleh, M. (2013). The Effect of Shading Devices on the Energy Consumption of Buildings: A Study on an Office Building in Dubai. In *SB13 Conference (Vol. 149)*.

YILDIZ, Y. (2014). Impact of Energy Efficiency Standard and Climate Change on Summer Thermal Comfort Conditions: A Case Study in Apartment Buildings. *Gazi University Journal of Science*, 27(3), 1005-1013.

Yıldız, Y., & Arsan, Z. D. (2011). Identification of the building parameters that influence heating and cooling energy loads for apartment buildings in hot-humid climates. *Energy*, 36(7), 4287-4296.

Yıldız, Y., 2008. Retrofitting existing mass housing for energy efficiency: A case study in Gazimir Emlak Bank Housing Area, İzmir, Turkey (Master's thesis, İzmir Institute of Technology).

Yoon, J. H., Song, J., & Lee, S. J. (2011). Practical application of building integrated photovoltaic (BIPV) system using transparent amorphous silicon thin-film PV module. *Solar Energy*, 85(5), 723-733.

Young, N. W., Jones, S. A., & Bernstein, H. M. (2008). Building Information Modeling (BIM)-Transforming Design and Construction to Achieve Greater Industry Productivity. *SmartMarket Report*, 48.

Young, N. W., Jones, S. A., Bernstein, H. M., & Gudgel, J. (2009). The business value of BIM-getting building information modeling to the bottom line. Bedford, MA: McGraw-Hill Construction, 51.

Zhang, J., Schmidt, K., & Li, H. (2016). BIM and sustainability education: Incorporating instructional needs into curriculum planning in cem programs accredited by ACCE. *Sustainability*, 8(6), 525.

Zhu, J., & Li, D. (2015). Current Situation of Energy Consumption and Energy Saving Analysis of Large Public Building. *Procedia Engineering*, 121, 1208-1214.

Zhu, P. (2014). Energy Efficient Multi-Story Residential Buildings in China (Doctoral dissertation).



## CURRICULUM VITAE

### **PERSONAL INFORMATION**

Name and Surname: Renas SHERKO

Natioality: Iraqi

Birth place and date: Baghdad/ Iraq- 24/12/1985

Phone number: 05396878699

Email: [en.renas85@yahoo.com](mailto:en.renas85@yahoo.com)

### **EDUCATION**

	<b>Graduate school</b>	<b>Year</b>
Ph.D.	Hasan Kalyoncu University	2018
Master	Cyprus International University	2014
Bachelor	Baghdad University	2007

### **WORK EXPERIENCE**

<b>Year</b>	<b>Place</b>	<b>Enrollment</b>
2011-2012	Erbil/ Iraq	Planner and Estimator Engineer
2009-2011	Erbil/ Iraq	Building construction supervisor engineer
2008-2009	Erbil/ Iraq	Highway construction supervisor engineer

## **PUBLICATIONS**

### **Articles:**

Sherko, R., Arayici, Y. (2018). BIM Based Design Optimization Framework for the Energy Efficient Building Design in Turkey, *Tamap Journal of engineering*, **2018**, **39**, pp. 1-10.

### **Proceedings:**

Sherko, R., Arayici, Y., (November, 2017). “BIM Based Design Protocol for the Optimized Building Orientation and Material Selection in Turkey”. ICSF 2017 - International Conference on Sustainable Futures. Kingdom of Bahrain.

Sherko, R., Arayici, Y., (November, 2018). “BIM Based Design Optimization Framework for the Energy Efficient Building Design in Turkey”. IPCMC 2018 - International Project and Construction Management Conference. North of Cyprus, **accepted in June, 2018.**