

**JUNE 2019**

**M.Sc. in Electronics Computer**

**Sena TAŞ**

**HASAN KALYONCU UNIVERSITY  
GRADUATE SCHOOL OF  
NATURAL & APPLIED SCIENCES**

**APPLICATIONS OF THE PRESSURE EFFECT ON THE  
ELECTRICAL ENERGY: PIEZOELECTRIC EXAMPLE**

**M. Sc. THESIS  
IN  
ELECTRONICS COMPUTER**

**BY  
Sena TAŞ  
JUNE 2019**

**Applications Of The Pressure Effect On The Electrical  
Energy: Piezoelectric Example**

**Hasan Kalyoncu University**

**Electronics Computers**

**M.Sc. Thesis**



**Supervisor**

**Asst. Prof. Dr. Hasan Selçuk SELEK**

**Sena TAŞ**

**June 2019**



© 2019[Sena TAŞ]



**GRADUATE SCHOOL OF NATURAL & APPLIED  
SCIENCES INSTITUTE M.Sc. ACCEPTANCE AND  
APPROVAL FORM**

Electronics Computer Engineering Department M.Sc. (Master of Science) programme student **Sena TAŞ** prepared and submitted the thesis titled **Applications Of The Pressure Effect On The Electrical Energy: Piezoelectric Example** defended successfully on the date of **24/06/2019** and accepted by the jury as a M.Sc. thesis.

Position

Title, Name and Surname

Signature

Department/University

**M.Sc.Supervisor  
Jury Head**

Asst. Prof. Dr. Hasan Selçuk SELEK  
Electrical and Electronics Engineering  
Department Hasan Kalyoncu  
University

**Jury Member.**

Prof. Dr. Şerafettin ÖZBEY  
Electrical and Electronics Engineering  
Department Ardahan University

**Jury Member**

Asst. Prof. Dr. Bülent HAZNEDAR  
Computer Engineering Department  
Hasan Kalyoncu University

**This thesis is accepted by the jury members selected by the institute management board and approved by the institute management board.**

**Prof. Dr. Mehmet KARBUZCU**  
Director

**I hereby declare that all information in this document has been obtained and presented in accordance with academic rules and ethical conduct. I also declare that, as required by these rules and conduct, I have fully cited and referenced all material and results that are not original to this work.**

**Sena TAŞ**



## **ABSTRACT**

### **APPLICATIONS OF THE PRESSURE EFFECT ON THE ELECTRICAL ENERGY: PIEZOELECTRIC EXAMPLE**

TAŞ, Sena

M.Sc. in Electronic Computer

Supervisor: Asst. Prof. Dr. Hasan Selçuk SELEK

June 2019

50 pages

Energy needs have increased due to the rapid development of technology from the past to the present, rapid population growth and associated production increase. Fossil fuels are generally used to meet this need. In recent years in all countries; due to the facts that fossil fuels will be depleted and the use of these fuels harms nature, a vast amount of resources are spared for researches of alternative energy sources. The facts that they do not harm the nature, they will not be exhausted in the future, they use various sources (solar, wind, water, geothermal...), and that there is one or more alternatives appropriate for each country have increased interest in renewable energy sources.

In this study; the transformation of the movements of the living things (basically human) into electrical energy using piezoelectric materials was investigated. For this purpose, floor of 1 m<sup>2</sup>, which can harvest was formed. The energy harvesting floor is designed using low-cost materials. In the floor design, piezodiscs with thicknesses of 0.33 mm and 1mm were used separately to analyze the floor. For the floor formed with piezodiscs of 0.33 mm thickness, \$ 28.58 was spent and a maximum of 3,976 mW was produced as a result of the walking of a person weighing 60 kg for 1 minute. Approximately \$ 50.16 was spent for the floor created with 1mm thick piezodiscs, and 4,029 mW was produced as a result of the walking of a person weighing 60 kg on it for 1 minute. The result of the experiment is that the current produced is very small, and that the costs of the renewal of damaged materials, initial

installation and operating costs are quite high. It was observed that the cost of storage of the energy generated from the floor does not have economic value when coupled with production cost, material and operating costs. At the same time, the energy produced does not have the power to be used. In a much larger area, with a greater number of people (Shopping entrances, factory establishments...) a certain level of energy can be obtained but it will not be efficient.

Therefore, it is not possible to operate with piezoelectric materials by establishing an efficient clean energy system with the design in the study or with similar designs. The different design works need to be sustained in order to use the materials in the industrial area. It is believed that the thesis study will be the source of further studies in this field. For this purpose, all the design steps are shown, the materials are introduced and the technical information is included faultlessly in the study.

**Keywords:** Energy, Alternative energy, Renewable energy, Piezoelectric, Energy harvesting, Clean energy

## ÖZET

### BASINÇ ETKİSİNİN ELEKTRİK ENERJİSİNE ÇEVİRİLMESİ UYGULAMALARI: PİEZOELEKTRİK ÖRNEĞİ

TAŞ, Sena

Yüksek Lisans Tezi, Elektronik Bilgisayar

Tez Yöneticisi: Dr. Öğr. Üyesi Hasan Selçuk SELEK

Haziran 2019

50 sayfa

Geçmişten günümüze teknolojinin hızla gelişmesi, hızlı nüfus artışı ve buna bağlı üretim artışı gibi etkenlerle enerji ihtiyacı artmıştır. Bu ihtiyacı karşılamak amacıyla genelde fosil yakıtları kullanılmaktadır. Son yıllarda tüm ülkelerde; fosil yakıtların tükenecek olması ve bu yakıtlarının kullanımının doğaya zarar vermesi nedeniyle alternatif enerji kaynakları araştırmalarına ciddi kaynak aktarmaktadır. Doğaya zarar vermemeleri, gelecekte tükenmeyecek olmaları, çeşitli kaynakları (güneş, rüzgâr, su, jeotermal ...) kullanmaları, her ülkeye uygun bir veya daha fazla alternatif olması yenilenebilir enerji kaynaklarına ilgiyi artmıştır.

Bu çalışmada piezoelektrik malzemeler kullanılarak canlıların (temelde insan) hareketlerinin elektrik enerjisine çevrilmesi araştırılmıştır. Bu amaçla, enerji hasadı yapılabilen 1 m<sup>2</sup> zemin oluşturulmuştur. Enerji hasadı zemini düşük maliyetli malzemeler kullanılarak tasarlanmıştır. Zemin tasarımında 0.33mm kalınlıkta piezodisk ve 1mm kalınlıkta piezodisk ayrı ayrı kullanılarak zemin tasarımı yapılarak analiz yapılmıştır. 0.33mm kalınlıktaki piezodiskler ile oluşturulan zemin için 28,58 \$ harcanmış ve 60 kg bir insanın 1 dakika yürümesi sonucunda maksimum 3,976 mW üretmiştir. 1mm kalınlıktaki piezodiskler ile oluşturulan zeminin için yaklaşık 50,16 \$ harcanmış ve 60 kg bir kişinin üzerinde 1 dakika yürümesi sonucunda 4,029 mW üretmiştir. Deney sonucunda üretilen akımın çok küçük olması, zarar gören malzemelerin yenilenme maliyetleri, ilk kurulum ve işletme maliyetleri oldukça yüksektir. Zeminden üretilen enerjinin depolama maliyetinin; üretim maliyeti,



malzeme ve işletme maliyetleri ile birleştğinde ekonomik değeri olmadığı görülmüştür. Aynı zamanda üretilen enerji kullanılacak bir güce sahip değildir. Çok daha büyük alanda, çok daha fazla sayıda kişilerle (AVM girişleri, fabrika yemekhaneleri...) belli seviyede enerji elde edilebilir ancak verimli olmaktan uzak olacaktır.

Buradan hareketle piezoelektrik malzemelerle verimli bir temiz enerji sistemi kurarak işletmek çalışmadaki ve benzeri tasarımlarla mümkün olamamaktadır. Malzemenin endüstriyel alanda kullanılabilmesi için farklı tasarım çalışmalarının sürdürülmesi gerekmektedir. Tez çalışmasının, bu alanda kendinden sonraki çalışmalara kaynaklık edeceğine inanılmaktadır. Bu amaçla tüm tasarım adımları gösterilmiş, malzemeler tanıtılmış ve teknik bilgiler eksiksiz çalışmada yer almaktadır.

**Anahtar Kelimeler:** Enerji, Alternatif enerji, yenilenebilir enerji, Piezoelektrik, Enerji hasadı, Temiz enerji



To my family...

## **ACKNOWLEDGMENTS**

I would like to express my appreciation and deepest gratitude to my supervisor Asst. Prof. Dr. Hasan Selçuk SELEK for his supervision, encouragement and endless support during me research. His contribution to the interpretation of the experiments conducted for this study is invaluable.

I would like to thank Hasan Kalyoncu University KALİTTO team for providing a suitable environment for conducting the experiments.

Finally, I would like to express my deepest gratitude to my family for their never-ending support, encouragement and unconditional love through all my life.

## **PREFACE**

In order to meet the increasing energy needs, the whole world has gone towards to alternative energy sources. Also, world want to have the energy that is directly related to the economy, in a cheap way. In Turkey which is dependent on foreign energy, new strategies have been developing to increase energy production. In this study, piezoelectric material which is an alternative energy source has been investigated and it is aimed to design a longest lasting floor with minimum cost. Accordingly, all the design steps are shown, the materials are introduced and technical information is included faultlessly in the study.

I would like to thank my supervisor Asst. Prof. Dr. Hasan Selçuk Selek who shaped my study in the light of scientific foundations with his guidance and informatics in his planning, research, implementation and formation.

## TABLE OF CONTENTS

|  |      |
|--|------|
| ABSTRACT.....  | I    |
| ÖZET .....   | III  |
| ACKNOWLEDGMENTS .....  | VI   |
| PREFACE.....   | VII  |
| TABLE OF CONTENTS.....   | VIII |
| LIST OF TABLES.....  | X    |
| LIST OF FIGURES .....  | XI   |
| LIST OF SYMBOLS/ABBREVIATIONS .....                                      | XIII |
| CHAPTER I .....  | 1    |
| INTRODUCTION.....  | 1    |
| 1.1 A Glimpse of energy in the world and in Turkey .....                 | 3    |
| 1.2 Piezoelectric History and Definition.....                            | 7    |
| 1.2.1. Types of Piezoelectric Materials .....                            | 9    |
| 1.2.2. Usage Areas of Piezoelectric Materials .....                      | 10   |
| 1.3. Literature Review.....  | 11   |
| 1.4. Purpose of Thesis .....   | 15   |
| CHAPTER II .....   | 17   |
| DESIGN OF A HARVESTER .....  | 17   |
| 2.1. Materials .....   | 17   |
| 2.1.1 AC-DC Converter Circuit .....                                      | 21   |
| 2.1.1.1 Full Wave Bridge Rectifier Circuit .....                         | 22   |
| 2.1.1.2. Villard Cascade .....   | 23   |
| 2.2. Experiment Without Piezodisc Home .....                             | 23   |
| 2.3 Experiment Using Piezodisc Home .....                                | 24   |
| 2.4 Experiment selection of the circuit to be used in floor design ..... | 27   |
| 2.4.1 Full Wave Bridge Rectifier Circuit Experiment .....                | 28   |
| 2.4.2 Experiment With Villard Cascade Circuit .....                      | 30   |
| 2.5 Design of Harvester Floor .....                                      | 32   |
| 2.6 Cost of Design .....   | 38   |
| CHAPTER III.....   | 39   |
| EXPERIMENT RESULTS .....   | 39   |
| CHAPTER IV.....  | 43   |
| DISCUSSION.....  | 43   |
| CONCLUSIONS.....   | 45   |
| 5.1 Conclusions .....  | 45   |

|                       |    |
|-----------------------|----|
| 5.2. Suggestions..... | 45 |
| REFERENCES.....       | 47 |



## LIST OF TABLES

|  | <b>Page</b> |
|--|-------------|
| <b>Table 1.1</b> Turkey energy production target .....   | 7           |
| <b>Table 2.1</b> Features of piezodisc .....   | 17          |
| <b>Table 2.2</b> Voltage and frequency values of piezodisc home according to hole diameter and height.....                   | 26          |
| <b>Table 2.3</b> Average voltage and current values produced by full wave bridge rectifier and villard cascade circuit ..... | 32          |
| <b>Table 2.4</b> Prices of used materials .....  | 38          |
| <b>Table 3.1</b> Total cost of floors designed with 0.33mm and 1mm piezodiscs .....  | 42          |

## LIST OF FIGURES

|   | <b>Page</b> |
|---|-------------|
| <b>Figure 1.1.</b> Royalty of electricity generation as regards energy sources of turkey in 2017..... | 1           |
| <b>Figure 1.2.</b> Classification of energy.....  | 4           |
| <b>Figure 1.3.</b> Parts of piezodisc .....   | 8           |
| <b>Figure 1.4.</b> Behavior of piezoelectric material .....   | 9           |
| <b>Figure 1.5.</b> Ultrasound probe structure (duran et al. 2006). .....                              | 10          |
| <b>Figure 1.6</b> Keyboard design with piezoelectric materials (şenyürek and demetgül, 2015) .....    | 13          |
| <b>Figure 1.7.</b> Spring floor (naresh et al. 2018). .....   | 15          |
| <b>Figure 2.1</b> Signal generated when pressure is applied to the ceramic .....                      | 18          |
| <b>Figure 2.2</b> Signal formed after pressure applied to metal part .....                            | 18          |
| <b>Figure 2.3.</b> Applying pressure on the ceramic part of the piezoelectric material .....          | 19          |
| <b>Figure 2.4.</b> Applying pressure from behind of piezodisc .....                                   | 19          |
| <b>Figure2.5.</b> Piezodisc home .....  | 20          |
| <b>Figure 2.6.</b> Piezodisc leg .....  | 21          |
| <b>Figure 2.7.</b> Capacitor selection .....  | 22          |
| <b>Figure 2.7.</b> Full wave bridge rectifier circuit.....  | 23          |
| <b>Figure 2.8</b> Villard cascade circuit .....   | 23          |
| <b>Figure 2.9.</b> Material used in pressure application.....   | 24          |
| <b>Figure 2.10.</b> Signal produced without piezodisc home .....                                      | 24          |
| <b>Figure 2.11.</b> Created system .....  | 25          |
| <b>Figure 2.12</b> Voltage signal generated by piezodisc home.....                                    | 25          |
| <b>Figure 2.13</b> Panel with 30 cm width and length .....  | 27          |
| <b>Figure 2.14</b> Full-wave bridge rectifier circuit .....   | 28          |
| <b>Figure 2.15.</b> Floor connection diagram .....  | 28          |
| <b>Figure 2.16.</b> Test .....  | 29          |



|  |    |
|--|----|
| <b>Figure 2.17</b> Maximum voltage obtained by full wave rectifier circuit .....                       | 29 |
| <b>Figure 2.18</b> Maximum current obtained by full-wave rectifier circuit .....                       | 30 |
| <b>Figure 2.19.</b> Villard cascade circuit .....  | 30 |
| <b>Figure 2.20.</b> Maximum voltages obtained using villard cascade circuit .....                      | 31 |
| <b>Figure 2.21.</b> Maximum current value obtained by villard cascade circuit .....                    | 31 |
| <b>Figure 2.22.</b> Laying of harvested soil materials .....   | 33 |
| <b>Figure 2.23.</b> Harvesting floor .....   | 33 |
| <b>Figure 2.24.</b> Damaged piezodisc.....   | 34 |
| <b>Figure 2.25.</b> Serial connection of piezodisc outputs to full wave bridge rectifier circuit ..... | 35 |
| <b>Figure 2.26.</b> Parallel and serial connection of piezodisc outputs .....                          | 36 |
| <b>Figure 2.27.</b> Parallel connection of piezodisk outputs .....                                     | 37 |
| <b>Figure 3.1.</b> Piezodisc voltage signal with 1mm thickness.....                                    | 41 |

## LIST OF SYMBOLS/ABBREVIATIONS

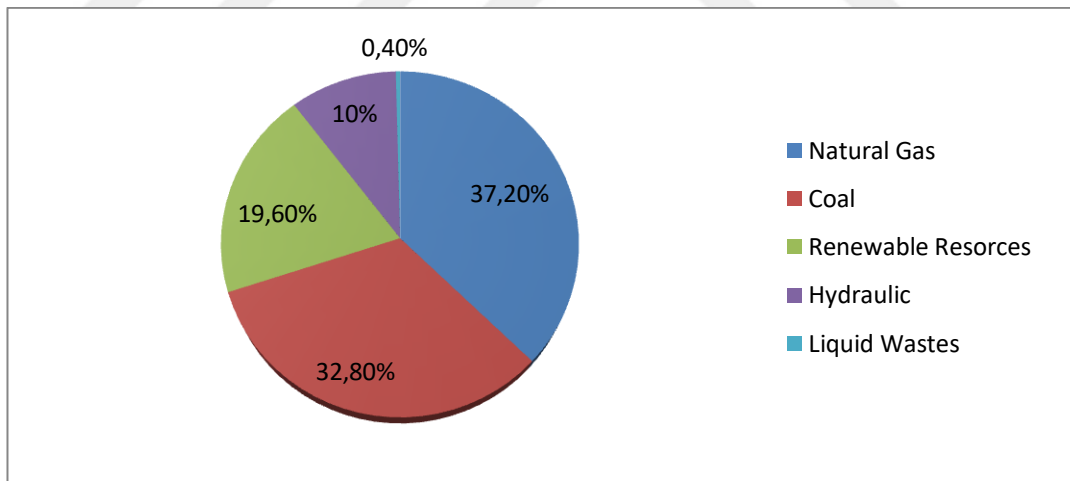
|                                      |  |
|--------------------------------------|--|
| \$                                   | Dollar   |
| $\mu\text{A}$<br>$10^{-6}$ amperes.) | Microampere (an SI unit of electrical current equal to   |
| $\mu\text{F}$                        | Microfarad ( $10^{-6}$ F)  |
| $\mu\text{W}$                        | Microwatt (an SI unit of power equal to $10^{-6}$ watts.)  |
| 3D                                   | 3-Diamention   |
| A                                    | Ampere (is the unit of electrical current.)  |
| ABS                                  | Acrylonitrile Butadiene Styrene  |
| AC                                   | Alternating Current  |
| cm<br>a meter)                       | Centimeter (a metric unit of length, equal to one hundredth of                                       |
| DC                                   | Direct Current   |
| GW                                   | Gigawatt (a unit of power equal to one billion $10^9$ watts.)  |
| Hz                                   | Hertz (is a unit derived from time which measures frequency<br>in the International System of Units) |
| J                                    | Joule (the SI unit of work or energy)  |
| Kg<br>of Units)                      | Kilogram (the basic unit of mass in the International System   |
| m                                    | Meter (a metric unit of length.)   |
| mA                                   | Milliamper ( $10^{-3}$ Ampere)   |
| MFC                                  | Macro Fiber Composites   |
| mm                                   | Millimeter ( $10^{-3}$ meter)  |
| MP3                                  | MPEG-1(Motion Pictures Experts) Audio Layer III  |
| mV                                   | Millivolt ( $10^{-3}$ volt)  |
| MW                                   | Megawatt ( $10^6$ watts)   |
| mW                                   | Milliwatt ( $10^{-3}$ watt.)   |
| nF                                   | Nanofarad ( $10^{-9}$ farads.)   |
| nW                                   | Nanowatt ( $10^{-9}$ watt.)  |

|                 |  |
|-----------------|--|
| pF              | Picofarad ( $10^{-12}$ farads)   |
| PFC             | Piezoelectric Fiber Composites   |
| PLA             | Polyactic Acid   |
| PV              | Photovoltaic   |
| PVDF            | Polyvinylidene Fluoride  |
| PZT             | Lead Zirconate Titanate  |
| R&D             | Resource and Development   |
| SONAR           | Sound Navigation and Ranging   |
| TOE             | Tons of Oil Equivalent (is a unit of the amount of energy resulting from the combustion of 1 ton of crude oil) |
| UFCCC           | United Nations Framework Convention on Climate Change  |
| V               | Voltage  |
| V <sub>pp</sub> | Peak to Peak Voltage   |
| W               | Watt (the SI unit of power)  |

## CHAPTER I

### INTRODUCTION

From the past to the present day, energy has been needed in areas such as lighting, heating, transportation and industry. As a result of the rapid developments in technology, this need has increased even more. Fossil fuels are preferred all over the world to meet energy needs. Consumption of fossil fuels, referred to as traditional fuel, accelerates the depletion of fossil fuels. In addition, the use of fossil fuels damages the environment. One of the reasons for global warming is the use of fossil fuels. Turkey's total electricity production in 2017 was 297.278 GWh. Distribution of production by area is given below. Accordingly, the conventional fuels; Natural gas, with 37.2% and coal with 32.8% have the biggest shares (Turkish Statistical Institute, 2019).



**Figure 1.1.** Royalty of electricity generation as regards energy sources of Turkey in 2017

Some countries are poor in terms of traditional energy resources. The poor countries obtain the energy they need through import. Therefore, energy is very costly for them. Turkey is one of the countries that are mostly dependent on foreign countries for energy, and energy constitutes the bulk of its imports. In 2015, domestic energy production in Turkey is 31.131,06 gross tonnes. In addition to this production, 112.850,71 gross tonnes of energy was imported. The energy exported is 8.427,36

gross tons. Turkey carried out energy import three times its production in 2015 (Saritaş et al., 2018).

According to the data of the year 2017, total energy consumption in Turkey was 107. 265. 393 TOE (Tons of Oil Equivalent). Turkey's fossil resources are poor and energy consumption is usually provided with fossil fuels which makes it a country dependent on foreign energy supply at the rate of 75% (Ertürk and Ertürk, 2018). Being aware of alternative energy sources, integrating them into production will render energy poor countries more efficient economically. Incentives for alternative energy sources have been initiated in Turkey as in some countries and it has been continuing increasingly.

Renewable energy sources are a great alternative to fossil fuels because they do not pollute the air we breathe and do not harm the nature and living things. The amount of energy produced using renewable energy sources is increasing day by day. This situation has greatly increased the popularity of piezoelectric material, an alternative energy source. They are the mechanisms used to produce piezoelectric energy (Rocha et al., 2010, Tüfekçioğlu, 2014). There are also studies regarding the obtainment of energy using piezoelectric materials, like other potential energy sources.

The piezoelectric material converts the pressure into electrical energy. They can generate electricity in almost any environment where the movement takes place. Due to these properties, they provide advantages over other alternative energy sources. Because, there is movement all over the world.

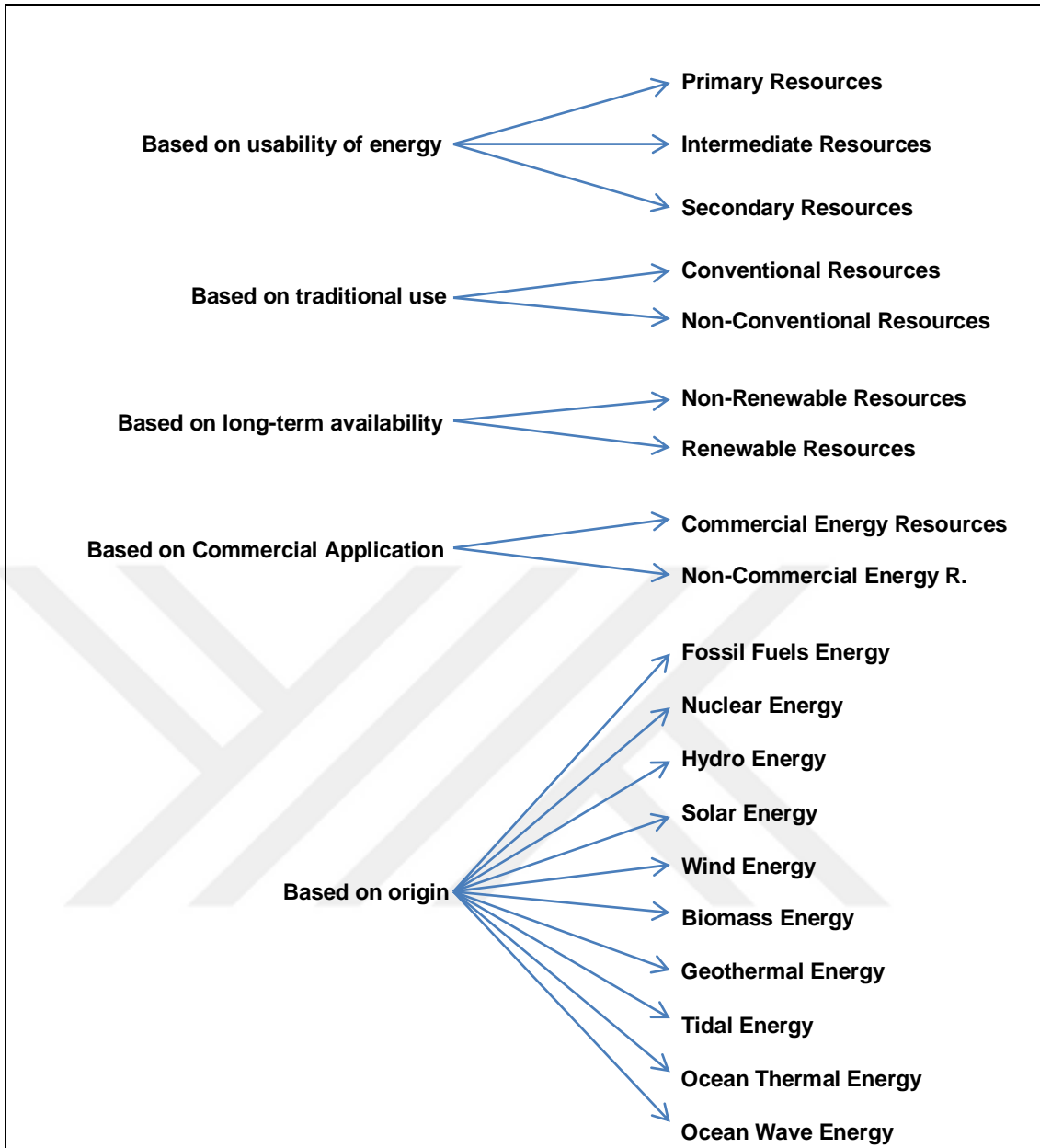
Considering the movements, human movement is the most appropriate motion for piezoelectric materials. In this study, the aim was to utilize the walking movement of people. Human movements in crowded places such as shopping centers, airports and schools can be used. The floors to be designed can be placed in areas where human movements are intense, and walking movements can be converted into electrical energy. It can be preferred to use in low power demanding areas such as local lighting in places where it is produced due to reasons such as the produced energy's being not big, high transportation and storage costs.

Fossil fuels are rapidly depleted and unfortunately the energy produced is unconsciously consumed. In the past, vehicles with larger motors used to be produced but today the increase in the use of hybrid vehicles can be given as an example for the increase in the level of consciousness. People should be informed more and their consciousness should be raised regarding the fossil fuels that are almost depleted and the damages that they do to nature. It should not be forgotten that the cheapest energy is the energy saved. People should also be directed to renewable energy sources. This will minimize the damage given to the environment and ensure the production of energy from clean energy sources.

In this project; an alternative energy source, piezoelectric material was used, and electrical energy production circuit design and analysis were performed with the lowest cost and longest lasting floor design.

### **1.1 A Glimpse of energy in the world and in Turkey**

The world has many energy sources. Energy sources can be classified under five titles as based on traditional use, based on long-term availability, based on commercial application, based on origin and based on the usability of energy. Figure 1.2 shows the energy sources of these titles (Khan, 2006).



**Figure 1.2.** Classification of energy

Some energy sources (coal, oil, natural gas ...) will disappear in the future. However, rapidly developing technology, increasing population, and growing demands increase the energy need. For this reason, new energy sources are searched all over the world.

The fact that fossil fuels are cheaper than other sources of energy enables fossil fuels to rank first in meeting the energy needs of countries (Baretto, 2015). In 2017, 70.33% of the electricity production in the world was obtained from fossil fuels (Ertürk and Ertürk, 2018). According to the researches, 33% of the energy consumed was produced from petroleum, 28.1% from coal, 24.1% from natural gas, 6.9% from hydraulic, 4.5% from nuclear and 3.2% from renewable sources (Koç et al., 2018).

This intensive use of fossil fuels, which will be completely exhausted in the near future, increases the exhaustion rate. In addition, the use of these traditional resources harms nature. Each year, 20 billion tons of carbon dioxide, 100 million tons of sulfur compounds, 2 million tons of lead and other toxin chemical compounds are spreading into the atmosphere. This situation causes global warming and acid rain (Kumbur et al., 2005). Global surface temperature increased approximately at the rate of 0.74 ° C from 1905 to 2005 (Ramakrishna et al., 2014). Due to the depletion of fossil fuels and the damage done on the environment, many countries have been inciting incentives for the use of renewable energy sources that do not harm the nature for their citizens and investors. Turkey also gives great importance to energy and environmental issues. Turkey wants to use energy resources efficiently in a way that will not harm the environment. Therefore, the Ministry of Energy and Natural Resources of the Republic of Turkey, aimed at empowering the country in the field of energy in its 2015-2019 strategic plan. As a result, the Republic of Turkey Ministry of Energy and Natural Resources set itself goals in areas such as domestic technology, result-oriented R & D (Research and Development) approaches and improvement of investment environments (Ministry of Energy and Natural Resources, 2014).

The United Nations Framework Convention on Climate Change (UFCCC), whose main objective is to counter climate change, was established in 1992 and the Kyoto Protocol was established in 1997. Turkey officially joined UFCCC on May 24, 2004 and the Kyoto protocol on August 26, 2009.

Some countries are poor countries in terms of fossil resources. These countries have to buy from other countries to meet their needs. Turkey is a poor country in terms of fossil resources. Turkey is dependent on foreign energy in a ratio of %75, at the same time, energy consists 15% of its imports. Oil is the leading among the most imported energy products in a ratio of 45%. This is followed by natural gas with 34% and coal with 21%. 1.1% of the natural gas production meets the consumption in Turkey. These figures clearly show the external dependence of Turkey. Besides, Turkey had 47.1 billion dollars of current account deficit in 2017 (Ertürk and Ertürk, 2018; Koç et al., 2018). In order to reduce foreign dependency, the production of renewable energy sources is recommended (Ertürk and Ertürk, 2018, Kumbur et al., 2005).



Renewable energy sources have an inexhaustible source of energy and do not harm the environment. Some countries provide incentives for the use of renewable resources. For example; in 2005, "Law on Utilization of Renewable Energy Resources for the Purpose of Generating Electrical Energy," numbered 5346 was the first step to promote the use of renewable energy sources in Turkey. Today, in Turkey, for the promotion of renewable energy sources;

- Value added tax exemption
- Customs duty exemption.
- Exemption from funds and surcharges (85% discount for the rent, access and use of power transmission lines for 10 years including the investment and operational periods of power plants which will be in operation before 2021).
- 50% discount on transmission system usage for 5 years from the start of the activity
- Exemption from stamp duty and fees (documents and transactions related to power plants and finalized within the investment period)
- Ability to operate without production license
- Fixed price guarantee (with extra supports provided for power plants manufactured with domestic added value)

incentives are available (Ulusoy and Daştan, 2018).

The Korean government has set targets under the name of "Low carbon and Green growth". To achieve these goals, the Korean government offers tax relief, financial assistance, R & D budget through new laws (Han and Shin, 2014).

At the end of 2016, 33.3% of the energy consumed all over the world was manufactured from petroleum, 28.1% from coal, 24.1% from natural gas, 6.9% from hydraulic, 4.3% from nuclear and 3.2% produced from renewable energy sources. Coal, which is one of the most consumed energy sources, will have been depleted in 114 years, natural gas in 53 years and oil in 51 years (Koç et al., 2018).

Table 1.1 Turkey energy production target

| <b>Technology</b>            | <b>Target</b> |
|------------------------------|---------------|
| Bio-power From Solid Biomass | 1GW           |
| Geothermal Power             | 1GW           |
| Hydropower                   | 34GW          |
| Solar PV                     | 5GW           |
| Wind Power                   | 20GW          |

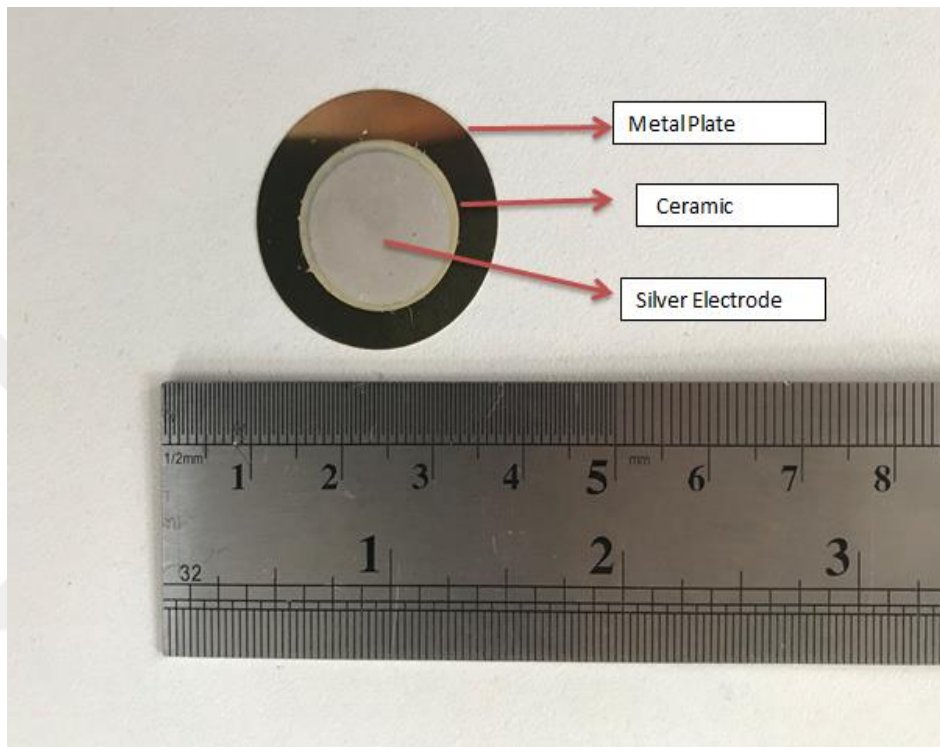
According to the Renewables 2016 Global Status Report, Turkey has the objectives set out in the table above until 2023(Ren21, 2016). Turkey's established renewable energy capacity in the year 2017 was 6872 MW of wind, 634 MW of bio energy, 3420 MW of solar, 1063 MW of geothermal and 27.273 MW of hydraulic energy. By the end of 2017, total renewable energy capacity in Turkey was 39.11 GW, and 32% of electric power generation was provided from renewable sources (Koç et al., 2018)

Energy has great importance. The need for energy increases as the technology develops. The world is exploring new alternative ways of energy production. Besides the energy production methods mentioned above, the energy of motion can be converted to electrical energy and used to meet the energy needs. There are many sources of movement such as helicopters, cars, trains, ventilation, air-conditioning systems, roads, railways, compressors, fans, ocean currents and wind.

## **1.2 Piezoelectric History and Definition**

Piezoelectric was found in 1880 by Pierre and Jacques Curie brothers. The word piezoelectric comes from the word “piezein” which means “suppressing” in Greek. It was used for the first time in history by Paul Lange in France to detect submarines.

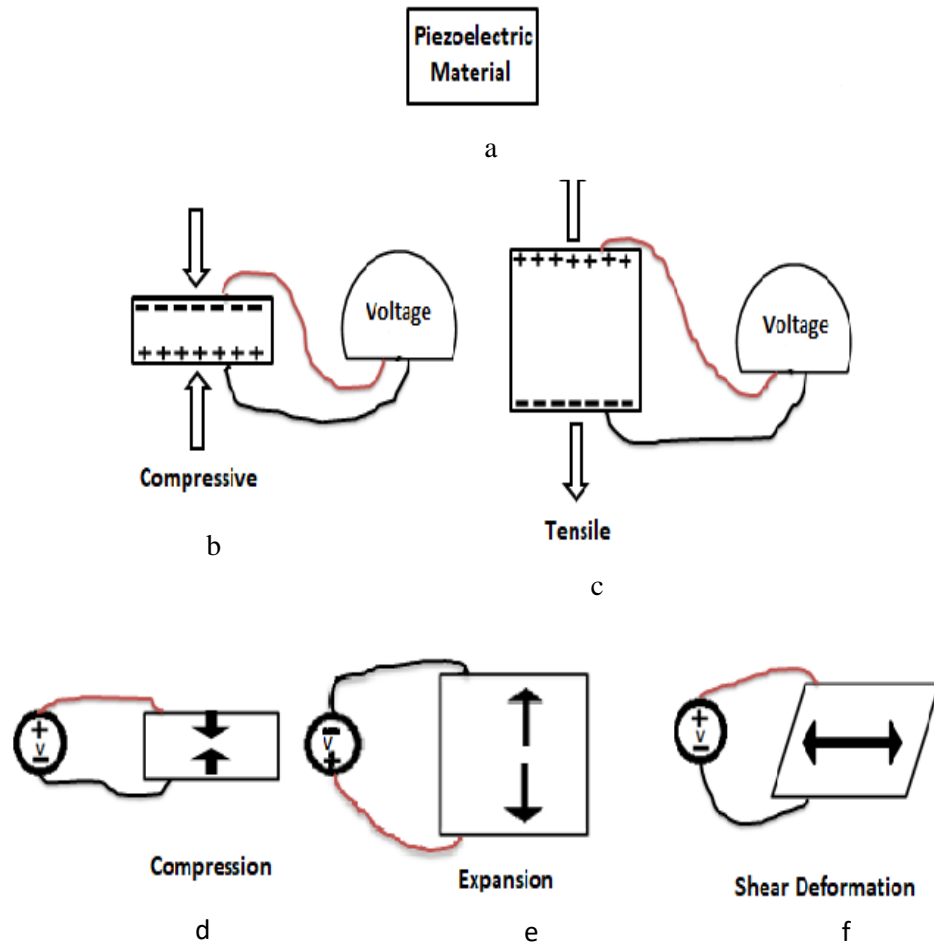
A piezodisc is given in Figure 1.3 below. Outside, there is a disc-shaped metal. On the metal, there is a ceramic surface. The interior of the ceramic is silver electrode. Piezoelectric materials have two different properties (direct and indirect effect). It is called direct effect, it can convert to electrical energy when pressure is applied on them. When applied to piezoelectric materials, the material changes shape. This feature is called indirect effect (Ergun et al., 2006; Rocha et al., 2010).



**Figure 1.3.** Parts of piezodisc

Responses of piezoelectric materials to applied pressure Figure 1.4 are also shown. When pressure is exerted on the material of Figure 1.4.a, as shown in Figure 1.4b, the positive and negative charges move away from each other in the material in a balanced manner. Therefore, different charges occur at both ends of the material. An electric field is formed between these two ends of the material and the potential difference is measured. It produces electricity in different directions during picking and pressing (Fig. 1.4.b and Fig. 1.4.c). When electric is applied to the piezoelectric material, the material performs expansion, compression and shear deformation (Figure 1.4.d, Figure 1.4.e and Figure 1.4.f) according to the direction of electricity (Ergün et al., 2006; Kholkin et al., 2008; Ramakrisha et al., 2014; Sappati and Bhadra, 2008).

When pressure is applied to piezoelectric materials, it can generate AC voltage. Therefore, the generated energy must be converted from AC to DC to be stored (Rani and Chhabra, 2016).



**Figure 1.4.** Behavior of piezoelectric material

### 1.2.1. Types of Piezoelectric Materials

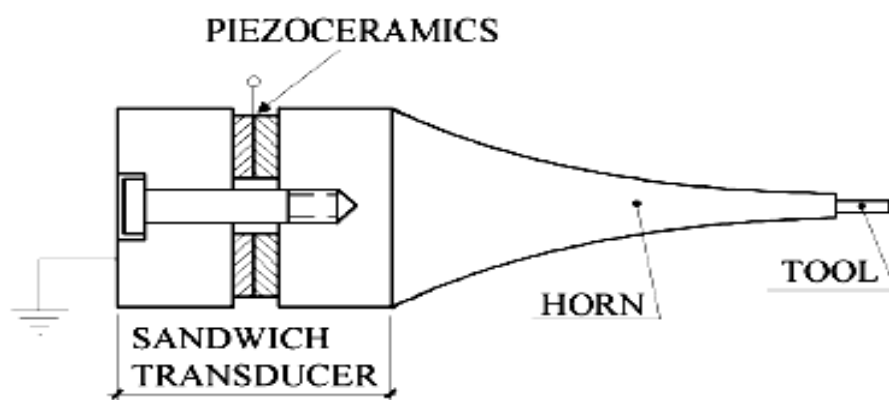
There are many types of piezoelectric materials such as Lead Zirconate Titanate (PZT), Polyvinylidene Fluoride (PVDF), Piezoelectric Fiber Composites (PFC), and Macro Fiber Composites (MFC). These are the most common piezoelectric materials. PZT is made of inorganic ceramic. It is known as a high performance piezoelectric material. It has a hard structure. PVDF is a piezoelectric material containing polymer and is flexible. It was found by Ford and Hanford. Because of this feature, PVDF can be used to produce electricity from body movements (in medical electronics applications) (Brown, 2000). PFC and MFC are very similar

materials. Their methods for creating fibers are different. PFC is as flexible as PVDF. However, PFC applications are less (Delnavaz and Voix, 2014).

### 1.2.2. Usage Areas of Piezoelectric Materials

The application areas of piezoelectric materials are quite wide. After the discovery of the piezoelectric material, it was not used until the First World War in a patent or other study (McGahey, 2009). It was first used in submarine technologies. Location of submarines was determined by using piezoelectric material. This technology is called Sonar. Ernest Rutherford and Poul Langevin worked on Sonar at the same time. They were unaware of each other's work. But Sonar was invented by Poul Langevin (Katzir, 2012).

The medical ultrasound device contains piezoelectric materials. Ultrasound devices can display the inside of the body with the help of the piezoelectric material they contain. Ultrasound devices have probes that can display inside the body. These probes contain piezoelectric material. Piezoelectric material can convert electricity to sound waves and sound waves to electrical signals. Thus it works as a transmitter and receiver. When electricity is applied to the piezoelectric material, it converts the electricity into mechanical energy and creates sound waves. These voices cannot be heard by people. Because they have high frequencies. Sound waves hit organs and return to probes. Then the piezoelectric material reads these sound waves. As a result, the ultrasound machine produces images. Figure 1.5 shows the structure of a probe (Duran et al. 2006).



**Figure 1.5.** Ultrasound probe structure (Duran et al. 2006).

Piezoelectric technology, which is widely used in medical devices, is the main material of Piezosurgery device which has become popular rapidly in recent days. The product, patented by Mectron Medical Technology (Italy), performs safe bone cutting in osteotomy surgeries, particularly in cosmetic surgeries. In this technology, ultrasonic waves are used in bone cutting; It prevents damage to soft tissues. Reduction of bleeding during and after surgery, decreasing edema and pain, rapidly replaces traditional external osteotomy (Robiony et al. 2004, Robiony et al 2016).

The direct property of piezoelectric material is used to measure mechanical quantities. For this reason, piezoelectric materials are used in diesel vehicle injector technology. The injector injects fuel to start the engine. In diesel vehicles, the Common Rail Fuel Injection System was replaced by the Piezoelectric Trigger Common Rail System. Piezoelectric Triggering The Common Rail System provides fuel control in diesel vehicles. In addition, this system can provide gradual spraying (Çanakçı and Özsezen, 2004)

In 2012, Hasan Selçuk SELEK designed a new metronome and percussion teaching set using piezoelectric material. With this program and device developed, the speed and the intensity of the beat can be measured and the accuracy of the piece analyzed by computer. Device in general; when hit on the pad, the piezoelectric material converts these signals into an electrical signal. This study showed that electricity and music can be used together (Selek, 2012). Nowadays, different versions of this work are presented by leading percussion instrument manufacturers with electronic tools.

Another field of application is the production of electricity, which is the subject of this thesis. It is desirable to use renewable energy sources because of the depletion of fossil fuels and environmental damage. Piezoelectric material is a renewable energy source such as solar, wind, geothermal. Therefore, it is used to generate electricity. There are many studies in this area.

### **1.3. Literature Review**

Recently; the use of piezoelectric technology has increased due to its ability to provide the energy needed by portable devices.

In 2010, Rocha and his friends designed shoes with the use of piezoelectric materials. The energy produced here is intended to be used to meet the energy needs of portable

devices. Prepared circuit board is placed in the shoe by shrinking. In addition, an electrostatic generator was added to increase power generation. In this study, 5 volts and 6 volts were produced without electrostatic generator and between 7 volts and 8 volts with electrostatic generator (Rocha et al., 2010).

In 2012, Ahmet Levent Avsar and Melin Sahin worked on the use of piezoelectric materials for electricity harvesting. They thought that the mini unmanned aerial and structural health monitoring sensors could take their energy from the piezoelectric material to meet their own energy needs. They investigated the amount of energy collected by finite elements and experimental techniques (Avşar et al., 2012).

Another project designed to ensure the energy production of portable devices is to collect energy from the jaw movements with flexible piezoelectric material. This project was designed by Dalvenaz and Voix in 2014. The daily chewing movement of man produces 580 J. This is equivalent to a power of approximately 7mW. They wanted to use this energy that is wasted. A device such as headphones was designed. However, this system was not able to produce the desired amount of energy (Dalvenaz and Voix, 2014).

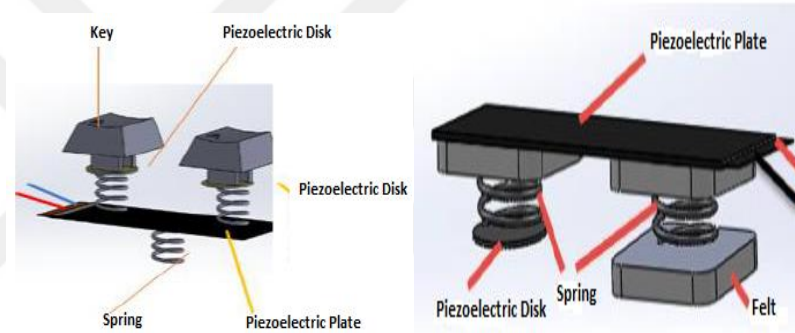
One of the best projects in this area is wearable pacemaker. Dağdeviren and his friends shared the results of the experiment to produce energy from the movements of internal organs. With this project, batteries will not be needed. Surgery is required to replace the batteries. Thus, this invention eliminated the operation (Dağdeviren et al., 2014, Dağdeviren et al., 2017).

Today, many electronic devices consume low power and are developed to consume even lower power. Especially portable devices; electronic devices such as headphones, calculator, telephone, MP3 electronic spend quite a bit of power. Having low powers with piezo-based circuits can provide sufficient energy for these devices.

A study in this area is “Woven Piezoelectric Structure for Stretchable Energy Harvester” by Yun et al. In order to be able to harvest energy, weaving that can be stretched was produced. The vertical polymer strands were fabricated using horizontal piezoelectric threads. 8 Hz tensile and stretching motions were applied on

the woven with the help of a mechanism and a maximum of  $0.6 \text{ mW} / \text{cm}^2$  was obtained (Yun and Yun, 2013).

Şenyürek and Demetgül have designed a keyboard that can produce its own energy. Two types of piezoelectric materials were used in this project. One of them is piezoelectric and the other is piezoelectric plate. Piezoelectric materials were obtained from American Piezo. The disc is 0.500 inches thick and has a diameter of 0.20 inches. The plate is 60 mm long, 20 mm wide and 0.69 mm thick. Şenyürek and Demetgül have designed two systems using a piezoelectric and two disc piezoelectric devices as shown in Figure 1.6. In the first design, a total of  $942.6 \mu\text{W}$  and  $532.5 \mu\text{W}$  in the second design. To recharge a battery whose power is known to be  $132\text{mW}$ , the keyboard should be pressed 158 times (Şenyürek and Demetgül, 2015).



**Figure 1.6** Keyboard design with piezoelectric materials (Şenyürek and Demetgül, 2015)

Researchers continue to conduct researches to produce electricity from renewable energy sources that have an eco-friendly and inexhaustible resource. Some researchers are working on converting the movement to electricity. In these studies, piezoelectric materials are commonly used to convert the movement into electricity. With the new designs, it is tried to produce solutions especially for low efficiency and easy distortion in materials. The thesis study was also done to serve this purpose.

Aslan aimed to produce electricity by putting piezoelectric materials under asphalt in 2016. In this study, carton was placed between the piezoelectric material and asphalt and the material was protected against deterioration. 2cm, 3cm and 4cm of asphalt was placed on the piezoelectric materials. A maximum of 3,16 V was obtained with the press machine by applying 100 bar pressure. It was observed that piezoelectric



materials were damaged and not a practical method despite the carton set (Aslan, 2016).

In 2006, New Energy and Industrial Technology Development Organization and JR East Consultanta Company and East Japon Railway Company designed the Power-generating Floor to produce electricity from the passengers' movements at the Marunoueli North exit of Tokyo Station. The floor placed in an area of  $6 \text{ m}^2$ . 10,000 watts per second energy production realized. However, materials within the floor were observed to deteriorate after 3 weeks. Therefore, electricity production decreased on the 3rd week (East Japan Railway Company, 2008). Both the errors in the design and the fact that the location was not easily controllable caused the experimental study to be far from the target.

In 2017, Funda Demir turned wind energy into electrical energy with piezoelectric materials in her doctoral thesis "Energy Harvesting with Piezoelectric Material from Wind". Using piezoelectric material in his study, he aimed to show that piezoelectric material is a source of clean energy. PZT and MFC examined the piezoelectric types and proved that MFC is more suitable for wind applications due to its flexible structure. When  $6.5 \text{ m/s}$  of wind intensity is applied in both materials; PZT 1445 nW produced MFC 121  $\mu\text{W}$  power (Demir, 2017).

In 2018, Derman Vatansever Bayramol created a piezoelectric weave from PVDF. He placed different materials under the piezoelectric fabric structure and observed the amount of production. First he put the weave on a steel plate. 860 mV peak voltages obtained from steel plate. Then he placed the weave on a mushroom-like soft plate. A 440 mV peak voltage was obtained from this plate. With this study, Bayramol proved that the location of the piezoelectric material is a very important criterion for obtaining high voltage (Bayramol, 2018).

Naresh and his friends designed a floor that transforms people's walking movements into electrical energy. The most widely used PVDF and PZT were preferred in their study. They obtained an average of 0.4 V from PVDF and 2V from PZT. Therefore they used PZT on the floor. As a result of 60 kg of people taking 250 steps on the floor, a 100W bulb burned for 6 seconds (Naresh et al. 2018). The floor is quite high from the floor as shown in the figure below. The floor with strings is closed when

pressed on the floor. This closure will make walking difficult for people. For this reason it will not be useful and people will not prefer walking on this mechanism.



**Figure 1.7.** Spring Floor (Naresh et al. 2018).

In this thesis, unlike the design of Naresh and his friends, a non-disturbing floor design was made. In addition to the production data, piezodisc damage data was also examined.

İkram Büyükkeskin, in his study titled as “Electricity Production From Wind Energy With Piezoelectric Materials” produced electricity in 2018 by using renewable and environment-friendly wind energy. He designed a prototype to produce electrical energy using wind energy and piezoelectric materials. He designed two different handles and a bed for piezoelectric materials. It was printed using 3D printer. Then he put his prototype on the wind tunnel. In the experiment, he obtained 380.73 W / cm<sup>2</sup> wind speed and maximum turbine speed of 17 m / s using different wind speed and turbulence. (Büyükkeskin, 2018)

#### **1.4. Purpose of Thesis**

The use of alternative energy resources has become popular due to increased energy demand, reduced carbon emissions in fossil fuel use and the depletion of fossil fuels. In addition to solar, geothermal and wind energy sources, new alternative energy sources are being investigated. Piezoelectric material is a renewable energy source, it does not harm the environment and it is cheaper than other renewable energy sources. In this study, a floor will be designed using piezoelectric materials to produce electricity. The first objective is to produce electrical energy from motion energy in crowded places such as airport, shopping center and school. People's movements are lost because they are not transformed into another form. This lost

energy is called waste energy. In this study, the amount of waste energies will be gained by converting to electrical form.

Harvest floor will be designed from low cost materials. For this purpose, low price piezoelectric materials and other materials will be taken.

The designed harvest floor will not allow people to spend a lot of energy during their walk and provide a comfortable walking environment. Damaged materials can easily be replaced in the floor.

At the end of this study, a low cost and long lasting floor design is aimed. The patent process will be initiated if the designed system is successful in the targeted way.



## CHAPTER II

### DESIGN OF A HARVESTER

In this section, the harvester design will be explained in headings.

#### 2.1. Materials

For the floor design, piezodisc materials named “Copper Piezo Disc” were bought from the “Your Cee” company in China. 1 piece of piezodisc price (November 2018) is \$ 0.03. The properties of the received piezodiscs are given in the table below.

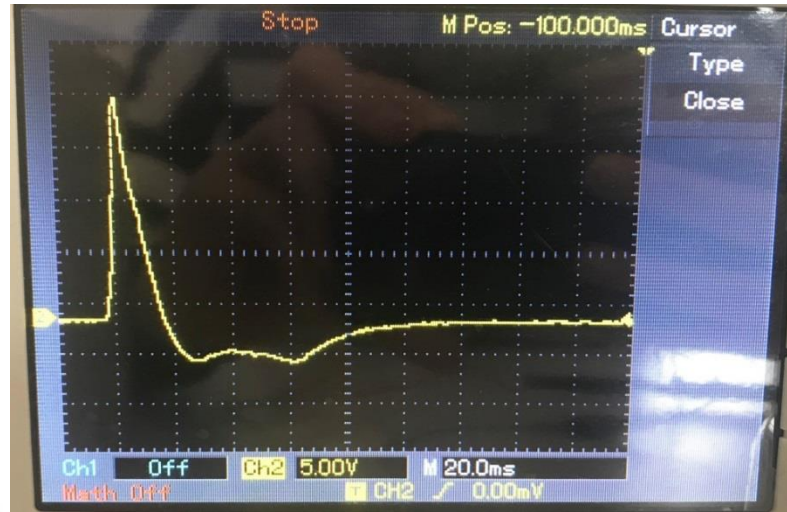
Table 2.1 Features of piezodisc

|                     |                                   |
|---------------------|-----------------------------------|
| External Diameter   | $27\text{mm} \pm 0.1\text{mm}$    |
| Inside Diameter     | $19\text{mm} \pm 0.2\text{mm}$    |
| Thickness           | $0.35\text{mm} \pm 0.05\text{mm}$ |
| Resonant frequency  | $4.1 \pm 0.5\text{KHz}$           |
| Resonant impedance  | $\leq 300 \text{ ohm max}$        |
| Static capacitance  | $28000 \text{ (PF)} \pm 30\%$     |
| Storage temperature | $-30 \text{ C} +70 \text{ C}$     |

Before the floor design, the present piezodiscs were examined. The way in which pressure on the piezodiscs was reacted, the way of working and physical changes were observed.

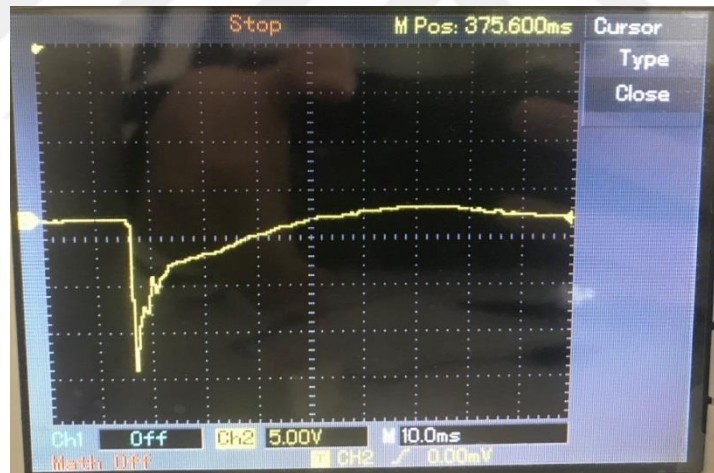
Firstly, the material was directly connected to the oscilloscope and the output signal was examined when the pressure was applied. When pressure was applied to the

ceramic part of the piezodisc, it produced a voltage signal in the positive direction as in figure 2.1.

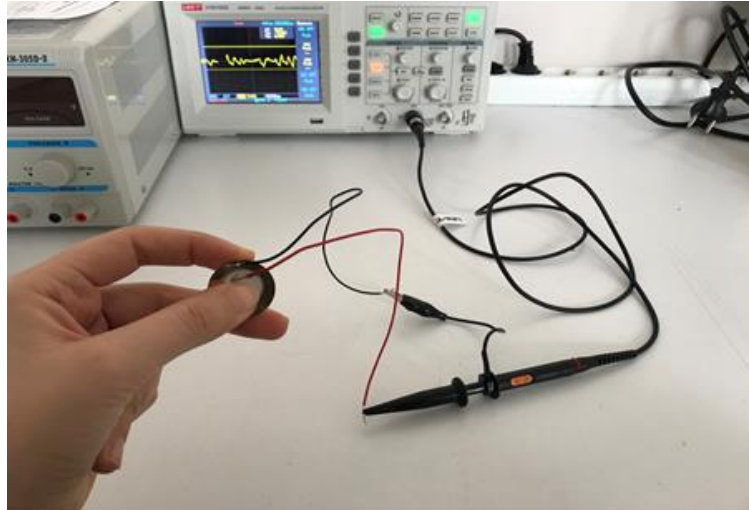


**Figure 2.1** Signal generated when pressure is applied to the ceramic

When the other side of the material is rotated and the pressure is applied to the metal part, the voltage signal is formed in the negative direction as in Figure 2.2.

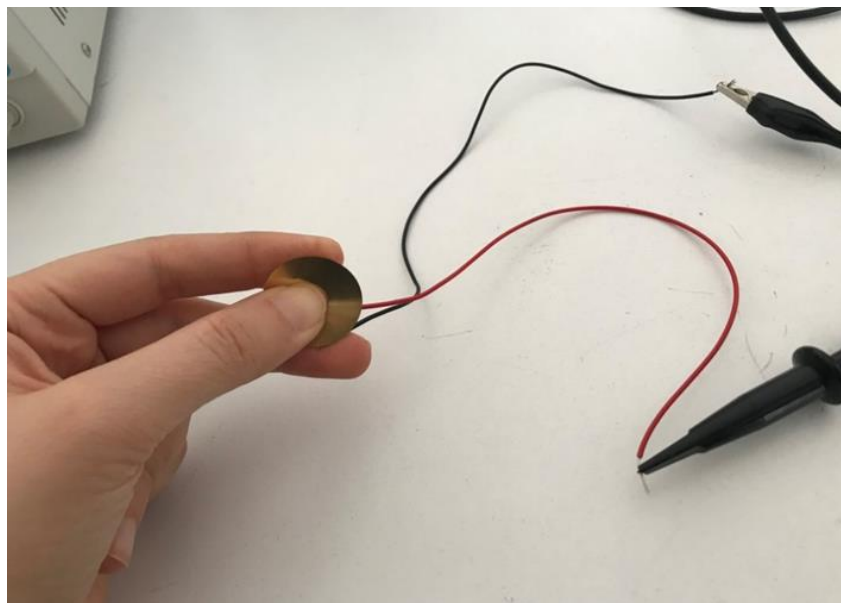


**Figure 2.2** Signal formed after pressure applied to metal part



**Figure 2.3.** Applying pressure on the ceramic part of the piezoelectric material

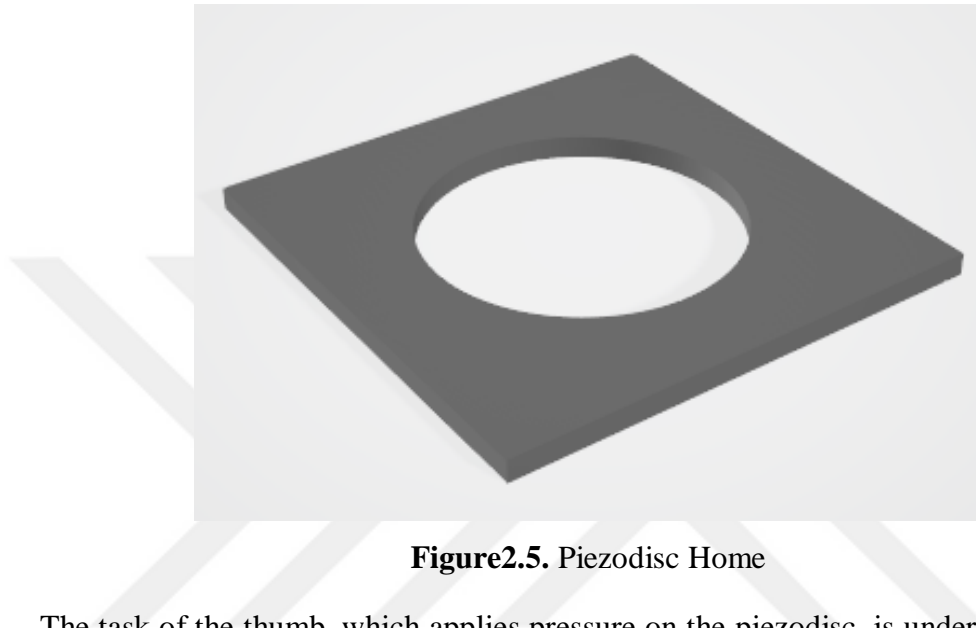
As shown in Figure 2.3, the piezodisc was placed between two fingers. Pressure was applied to the ceramic part with the thumb of the hand. As a result of this application, 10 volt voltage was produced. As shown in Figure 2.4, pressure was applied by inverting the material without changing the method of application. In this application the material was broken and damaged. In addition, the highest voltage output applied to the piezodisc in different ways was obtained by applying the ceramic part. As a result of the experimental studies; It is determined that the floor to be formed will be more suitable to apply pressure to the piezodisc ceramic part.



**Figure 2.4.** Applying pressure from behind of Piezodisc

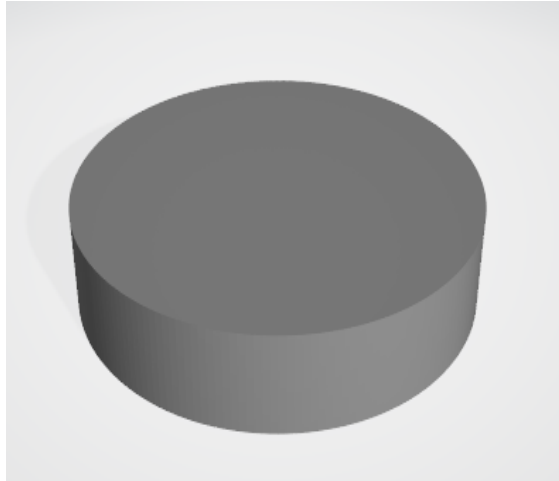
When pressure is applied on the harvesting floor, structures are designed in such ways that figure 2.1 are designed. The first of these structures is called Piezodisc

Home. The 3D Piezodisc Home drawn using AutoCAD is shown in Figure 2.5. This structure serves as the two fingers under piezodisc in the pressure application on the piezodisc ceramic. The piezodiscs used in this study have a diameter of 27 mm (See. Table 2.1). Piezodisc Homes are manufactured in 1.4mm height, 30 mm widths and lengths. The middle of this structure is a hole. When walking on the floor, this hole allows the piezodisc to move more, providing high voltage generation.



**Figure2.5.** Piezodisc Home

The task of the thumb, which applies pressure on the piezodisc, is undertaken by the second structure called leg. The leg was drawn using the AutoCAD program. This structure is shown in Figure 2.6. Designed leg has a diameter of 10 mm and a height of 2 mm. This material is placed in the exact center point of the piezodisc. When pressure is applied on the floor, pressure is applied to the piezodiscs, which are only laid in the floor with the help of the leg. In addition, piezodisc home and leg have a total height of 3.4 mm, so it does not allow the cables used in the floor to be damaged.



**Figure 2.6.** Piezodisc Leg

Both of the structures were printed using the ZAXE 3D printer at the ARBIM building of Hasan Kalyoncu University. PLA and ABS filaments were used in printing. The piezodisc home is designed in different sizes to find the highest production piezodisc home size. In Chapter I, in the literature review, Bayramol proved that the area in which the material is placed is important to obtain a high voltage (see p. 15). Therefore, piezodisc home hole has been designed in different sizes and examined. The results of the examination are given in Table 2.2 (See p. 27).

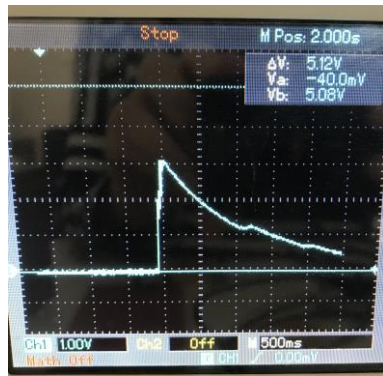
Since it is cheap and easily accessible, it is preferred to use wood panel in floor design. In addition, the cable is used to connect the piezodisc materials to the circuits.

### **2.1.1 AC-DC Converter Circuit**

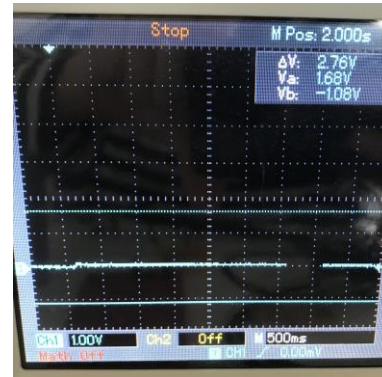
AC-DC converter circuit converts AC signal to DC signal. In this study, among the commonly used AC-DC converter circuits, full wave bridge rectifier circuit and Villard Cascade circuit were used. The same materials were used for comparison in both cycles.

To determine the capacitor value to be used, 1 piezoelectric material was connected to the Full Wave Bridge Rectifier circuit prepared with capacitors with different values. Piezoelectric material was placed on piezodisc homes and a pressure of 3,276 kg was applied. Then the output of the circuit is connected to the oscilloscope and the voltage stored by the capacitor is examined.

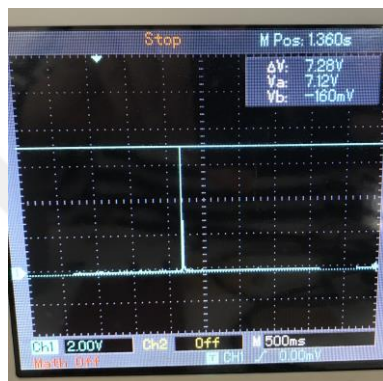




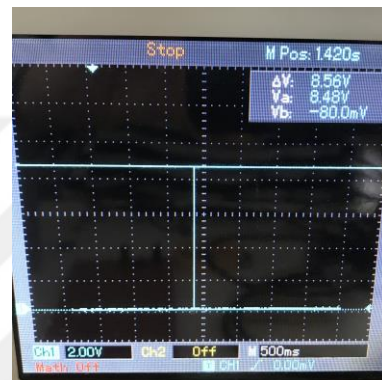
a.  $1\ \mu\text{F}$



b.  $10\ \mu\text{F}$



c.  $10\ \text{nF}$



d.  $22\ \text{pF}$

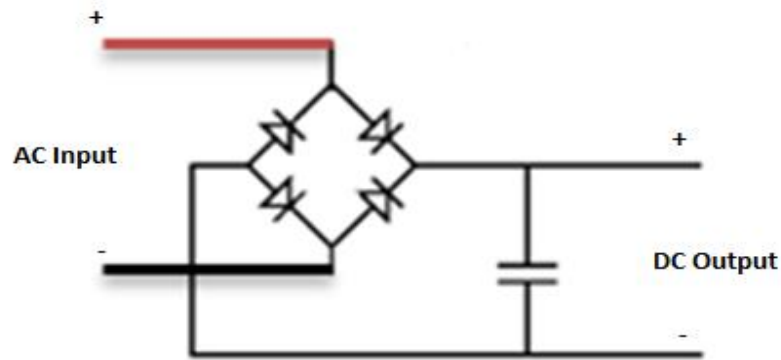
**Figure 2.7.** Capacitor selection

$1\ \mu\text{F}$ ,  $10\ \mu\text{F}$ ,  $10\ \text{nF}$  ve  $22\ \text{pF}$  produced different signals, when 3,276 kg material was placed on the piezodisc. The  $1\ \mu\text{F}$  capacitor saw a peak of about 3 V, a peak of  $10\ \mu\text{F}$  200 mV, a peak of  $10\ \text{nF}$  7.28 V, and a peak of  $22\ \text{pF}$  8.56 V. Compared with the voltage signals stored by the capacitors,  $1\ \mu\text{F}$  produced a more stable waveform. As a result,  $1\ \mu\text{F}$  will be used.

1N400X diodes are the most commonly used diodes. It will be used in rectifier circuits 1N4007 known as rectifier in the market.

### 2.1.1.1 Full Wave Bridge Rectifier Circuit

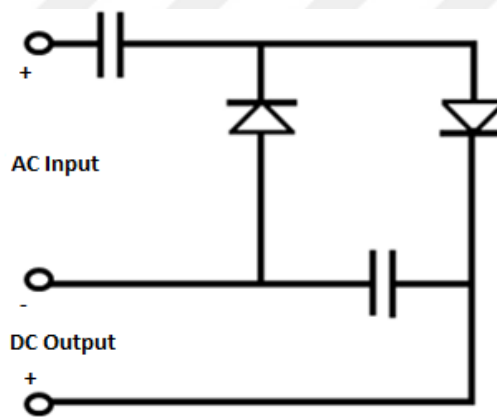
When AC signal is applied to input of Full Wave Bridge Rectifier Circuit, DC signal is obtained from output.



**Figure 2.7.** Full wave bridge rectifier circuit

As shown in Figure 2.7, Full Wave Bridge Rectifier Circuit converts AC signal to DC signal. Full Wave Bridge Rectifier Circuit contains 4 diodes and 1 capacitor.

### 2.1.1.2. Villard Cascade



**Figure 2.8** Villard Cascade Circuit

Villard Cascade converts AC signal to DC signal in circuit. In the design of this circuit, 2 pieces of 1N4007 diodes and 2 pieces of 1  $\mu$ F capacitors were used. Figure 2.8 shows the Villard Cascade circuit (Floyd, 2012).

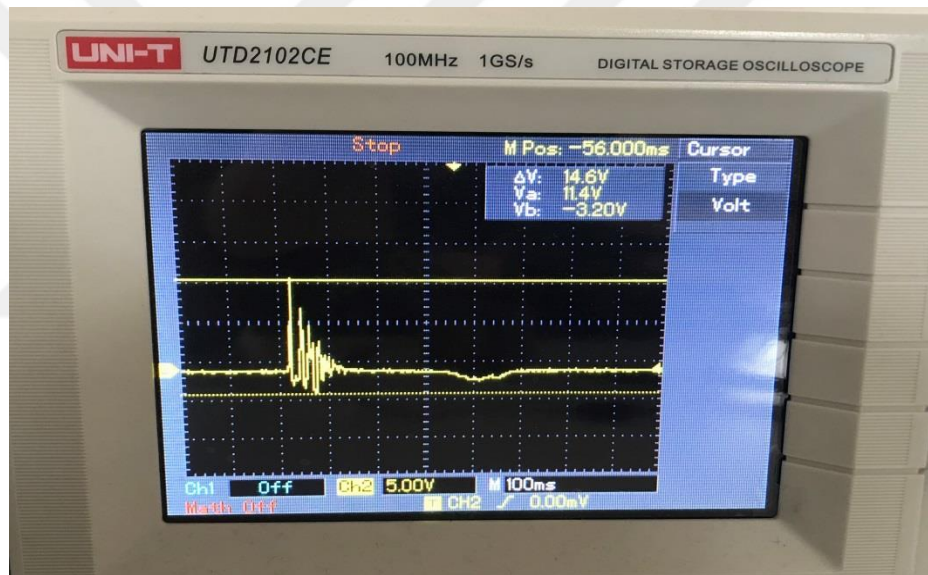
## 2.2. Experiment Without Piezodisc Home

The red cable was soldered to the ceramic part of the piezodisc and the black cable to the metal part. Cable ends are connected to the oscilloscope. Piezodisc was placed on a table and pressure was applied.



**Figure 2.9.** Material Used in Pressure Application

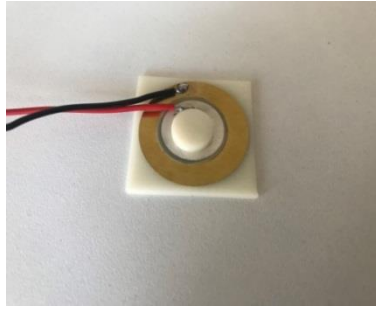
In the figure above, a pressure of 3,276 kg of material was applied to the materials. When the material was put on the piezodisc, the signal in Figure 2.10 was formed. The resulting signal was 14.6 Vpp and 9.259 Hz.



**Figure 2.10.** Signal produced without Piezodisc Home

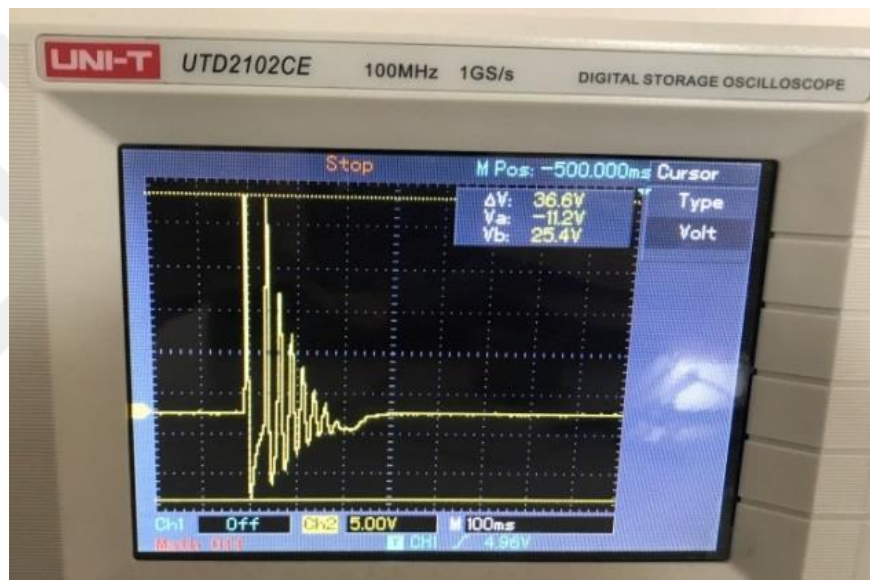
### 2.3 Experiment Using Piezodisc Home

As in the previous experiment, the red cable was soldered to the ceramic part, the black cable to the metal part. Then piezodisc was attached to the designed piezodisc home. The leg was glued onto the ceramic part of piezodisc. The entire bonding process was performed using 502 adhesive. The structures produced with PLA filament were easily glued but the structures produced with ABS material were not glued easily. Figure 2.11 shows the generated system. Finally, the cable ends are tested by connecting the oscilloscope with the probes.



**Figure 2.11.** Created system

The best size finding test was performed for high voltage production. In Figure 2.12, the signal formed as a result of placing the metal on the piezodisc home that has a hole of 18 mm diameter is shown.



**Figure 2.12** Voltage signal generated by piezodisc Home

Different size Piezodisc Homes were printed on the 3D printer for review. Table 2.2 was formed with the information obtained from the experiment results.

Table 2.2 Voltage and frequency values of Piezodisc Home according to hole diameter and height

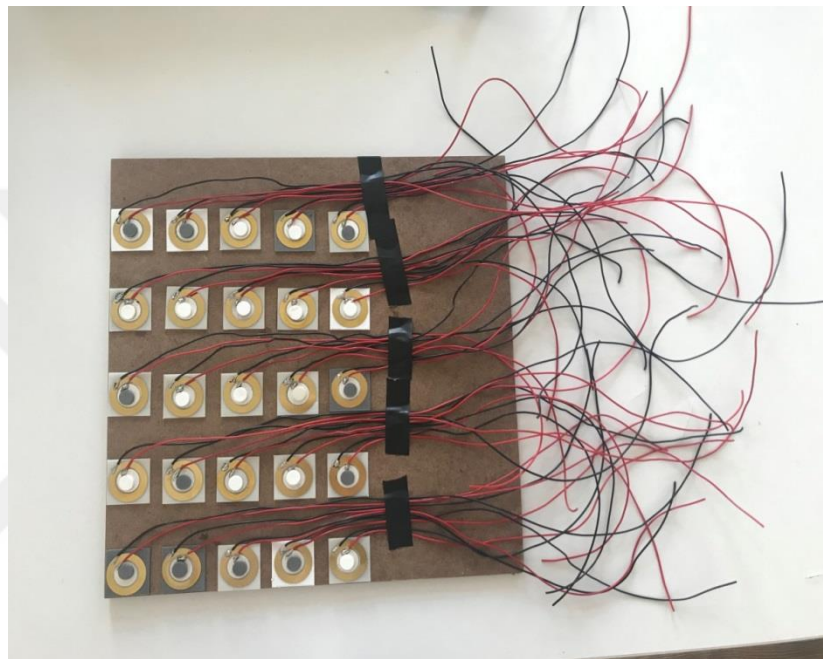
| <b>The Diameter of The Hole</b> | <b>The height of the Piezodisc home</b> | <b>V<sub>pp</sub><br/>(V)</b> | <b>Frequency<br/>(Hz)</b> |
|---------------------------------|---|-------------------------------|---------------------------|
| <b>16mm.</b>                    | <b>2mm</b>                              | <b>38.2</b>                   | <b>5.952</b>              |
|                                 | <b>1.4mm</b>                            | <b>41.5</b>                   | <b>5.102</b>              |
| <b>18mm</b>                     | <b>2mm</b>                              | <b>36.6</b>                   | <b>3.846</b>              |
|                                 | <b>1.4mm</b>                            | <b>44.4</b>                   | <b>6.410</b>              |
| <b>20mm</b>                     | <b>2mm</b>                              | <b>45.8</b>                   | <b>4.630</b>              |
|                                 | <b>1.4mm</b>                            | <b>43</b>                     | <b>6.098</b>              |
| <b>22mm</b>                     | <b>2mm</b>                              | <b>40.8</b>                   | <b>5.435</b>              |
|                                 | <b>1.4mm</b>                            | <b>50</b>                     | <b>3.788</b>              |
| <b>24mm</b>                     | <b>2mm</b>                              | <b>39.4</b>                   | <b>5.814</b>              |
|                                 | <b>1.4mm</b>                            | <b>44.4</b>                   | <b>5.319</b>              |

According to the result of the experiment, all piezodisc home sizes have almost the same result. The average voltage produced by piezodisc homes with a height of 2 mm is 40.16 V and the average frequency is 5,1354 Hz. The average voltage produced by piezodisc homes with a height of 1.4mm is 44.66 V and the average frequency is 5.3434 Hz.

As a result of the experiment with Piezodisc Home and leg, Piezodisc Home and leg will be used in the floor design to be made since it gives a better result than the result of the experiment without Piezodisc Home.

## 2.4 Experiment selection of the circuit to be used in floor design

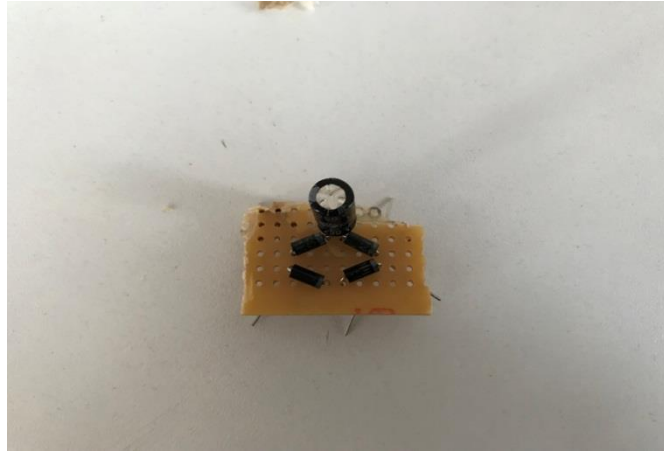
For this experiment, board panel with 30 cm width and length was used. Since it is cheap and easily accessible, it is preferred to use wood panel in floor design. The cables were soldered to the piezodisc. The prepared piezodiscs were attached to Piezodisc Home. It was glued Leg to the ceramic part of the piezodisc. The prepared system was placed on the wooden panel as shown in Figure 2.13. There are 25 piezodiscs on the panel. The cables are placed between the materials.



**Figure 2.13** Panel with 30 cm width and length

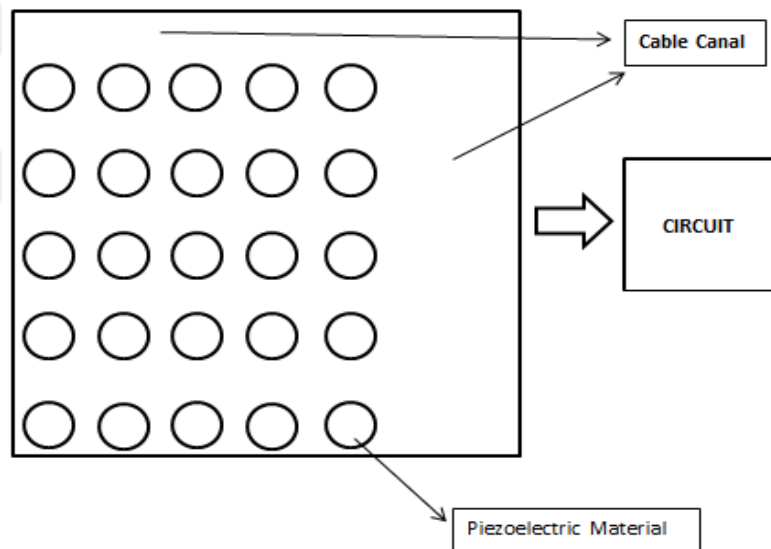
Panel was inverted down and, 60 kg person applied pressure to the prepared panel. No material in the panel was broken and the cables were not damaged.

An AC signal can be generated using piezodisc. “All active electronic devices operate with DC voltage” (Floyd, 2012). In addition, only DC voltage can be stored in the batteries. To obtain DC voltage, the AC voltage converter produced from the wooden panel is converted to DC voltage.



**Figure 2.14** Full-wave Bridge Rectifier circuit

Firstly, a Full-wave Bridge Rectifier Circuit is designed as shown in Figure 2.14. Then the output of the piezodisc in the wooden panel is connected to the input of the circuit. The connection diagram is shown in 2.15.



**Figure 2.15.** Floor connection diagram

#### **2.4.1 Full Wave Bridge Rectifier Circuit Experiment**

The prepared panel was inverted on a flat surface as shown in Figure 2.16. At the output of the circuit; measurements were made by placing the measuring instrument to measure the current, voltage and resistance.

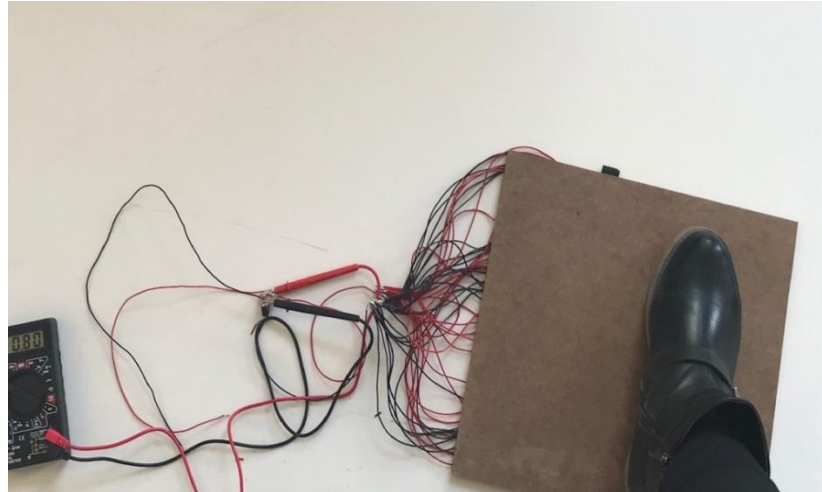


Figure 2.16. Test

In the experiment, a person with a weight of 60 kg pressed 20 times in the intervals on the prepared floor. The maximum voltage indicated by the multimeter at each press was noted. Figure 2.17 shows the maximum voltages.

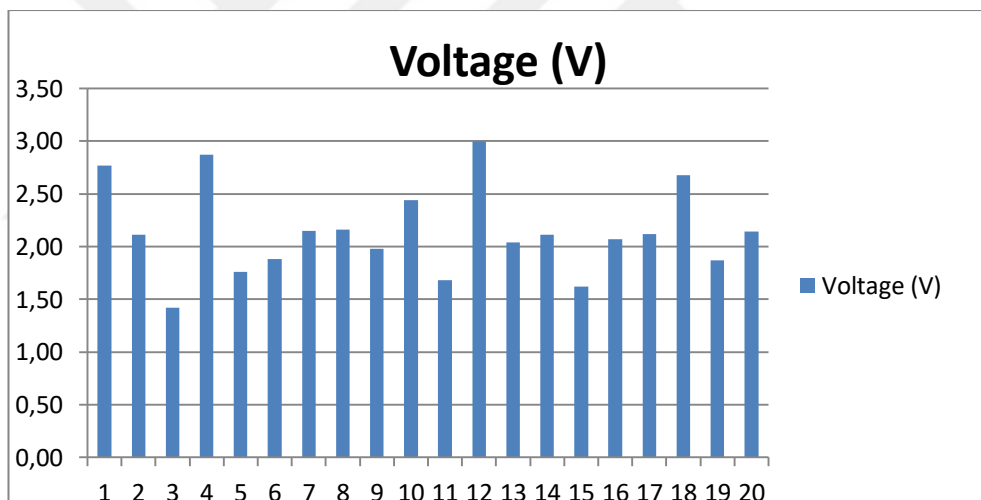
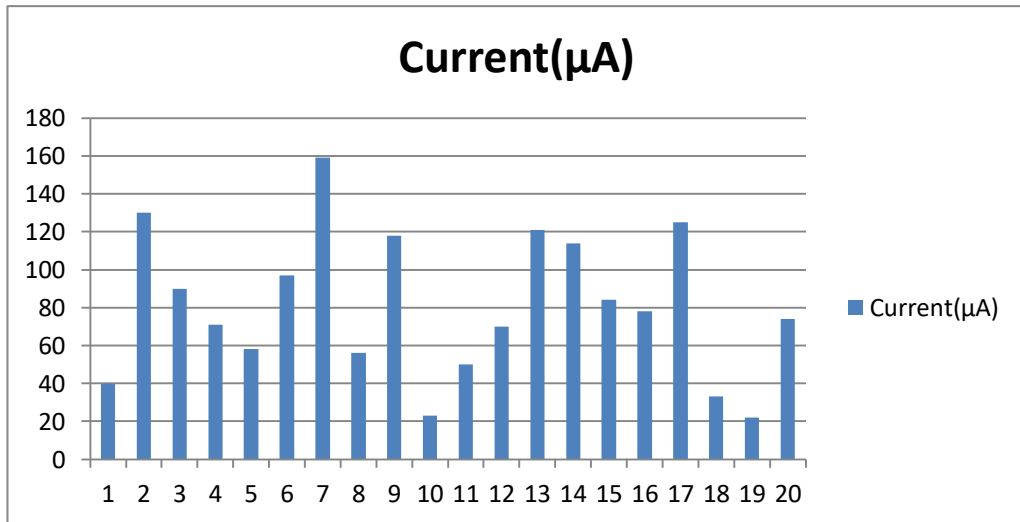


Figure 2.17 Maximum voltage obtained by full wave rectifier circuit

Maximum 1.42 V and 3 V voltage was obtained from the prepared floor. At the end of the experiment, the materials bonded to the wooden panel were examined and observed to be undamaged. An average of 2.46 volts of production was obtained from this floor.

The current value was measured as a result of a pressure of a 60 kg person after the voltage measurement. The maximum currents produced as a result of pressing the board 20 times again were noted. The maximum currents obtained in Figure 2.18 are shown.

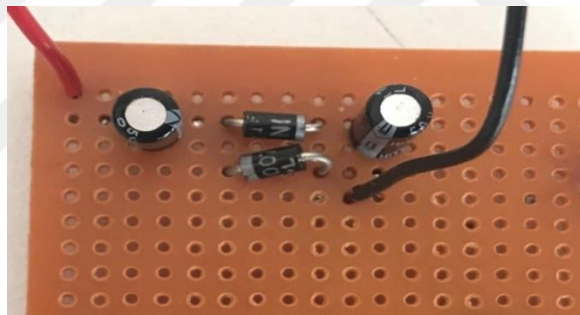




**Figure 2.18** Maximum current obtained by full-wave rectifier circuit

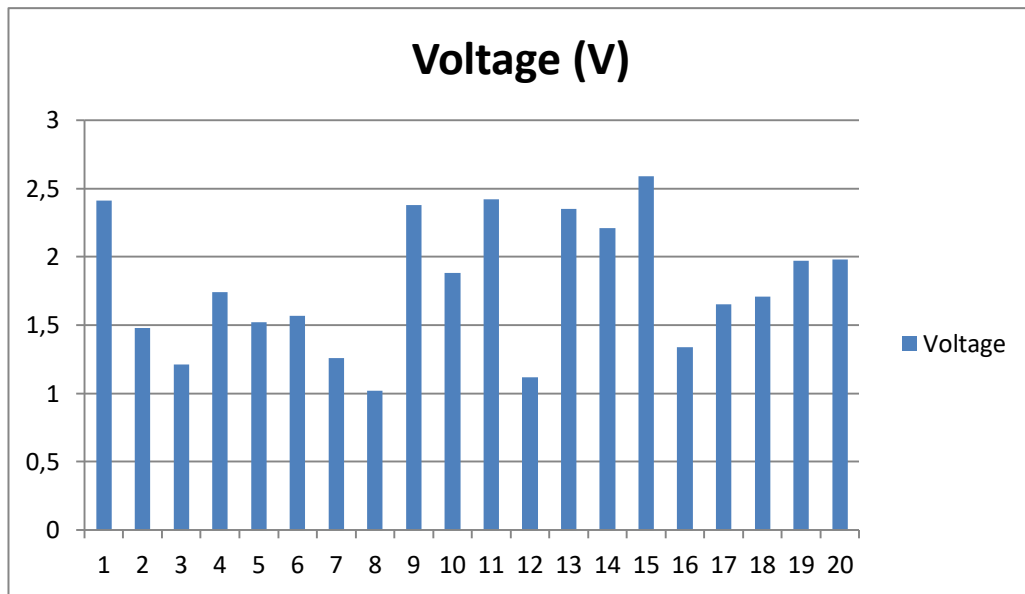
According to the results of the experiment, between 22  $\mu\text{A}$  and 159  $\mu\text{A}$  current was obtained. The average current produced is 57  $\mu\text{A}$ .

#### 2.4.2 Experiment With Villard Cascade Circuit



**Figure 2.19.** Villard Cascade Circuit

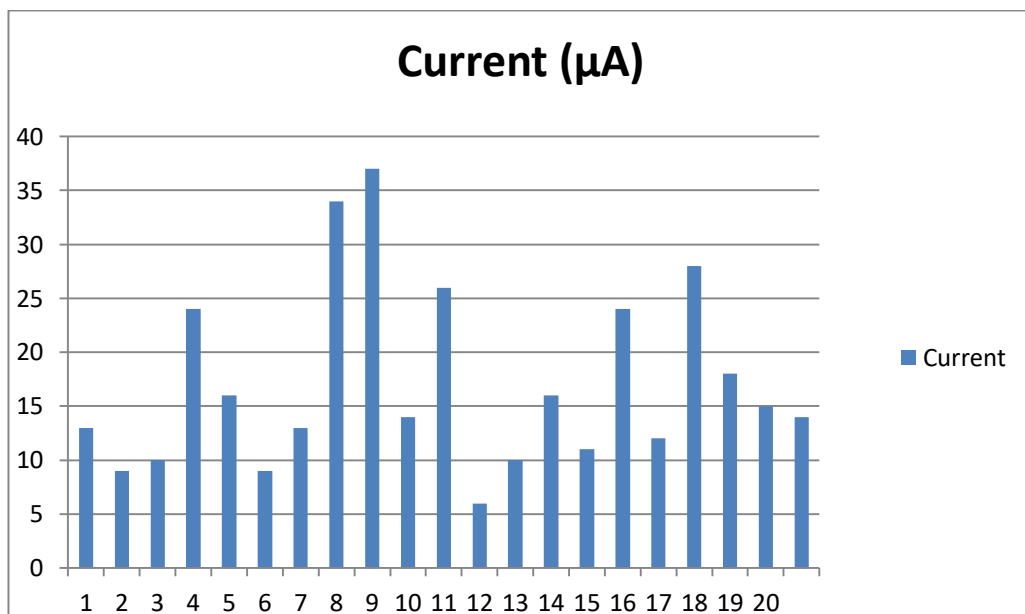
For the experiment, the floor used in the Full Wave Bridge Rectifier Circuit is used. The Villard Cascade circuit is shown in Figure 2.19, which is integrated into this floor. Again as in the previous experiment, the person with a weight of 60 kg pressed on the floor. The compression was carried out 20 times and the voltage values shown in Figure 2.20 were measured.



**Figure 2.20.** Maximum voltages obtained using Villard Cascade Circuit

Between 1.02 V and 2.59 V voltages were obtained from the floor using Villard Cascade. The average voltage generated is 2,195 V. After the experiment, the materials used on the floor were examined and observed to be not damaged.

The same floor and the same person were used in the measurement of the current using the Villard Cascade circuit. As a result of a person of 60 kg stepping on it 20 times, Figure 2.21 was created.



**Figure 2.21.** Maximum current value obtained by Villard Cascade Circuit

The floor designed as a result of the experiment produced current between 6 µA and 37 µA. The average current produced is 14 µA.

In the table below, the average production values of the Full Wave Bridge Rectifier Circuit and the Villard Cascade Circuit are compared.

Table 2.3 Average voltage and current values produced by Full Wave Bridge Rectifier and Villard Cascade Circuit

| <b>Circuit</b>                    | <b>Voltage (V)</b> | <b>Current (<math>\mu\text{A}</math>)</b> |
|-----------------------------------|--------------------|---|
| <b>Full Wave Bridge Rectifier</b> | <b>2.46</b>        | <b>57</b>                                 |
| <b>Villard Cascade</b>            | <b>2,195</b>       | <b>14</b>                                 |

It was observed that the average production values of the Full Wave Bridge Rectifier Circuit were higher than the Villard Cascade circuit. While there is a 12% difference between voltages, the difference between currents is around 300%. Taking this data into consideration, it was decided to design the harvested floor using the Full Wave Bridge Rectifier Circuit.

### **2.5 Design of Harvester Floor**

221 piezodiscs are affixed to the Piezodisc Homes. Then the leg is glued to the center of the ceramic parts of the piezodiscs. The cables are soldered with piezodisc. Created system was glued on the 1 m<sup>2</sup> wooden panel. 17 piezodiscs were glued together side by side and the cable outlets on the right side of the panel were soldered in parallel. This way 13 rows are placed in the board. All cables in the wooden panel are prevented from being damaged by passing between Piezodiscs Home. The generated wooden panel is shown in Figure 2.22.



**Figure 2.22.** Laying of harvested soil materials

Another panel of the same size was placed on the prepared wooden panel. All the outputs of the piezodiscs were connected in parallel and the experiment was performed by connecting to a Full Wave Bridge Rectifier Circuit.

During the whole experiment, the person with a weight of 60 kg walked on the designed floor.



**Figure 2.23.** Harvesting floor

A multimeter was placed at the circuit output of the prepared floor and walking was performed on the floor. When the 60 kg person moves 10 steps on the floor, the

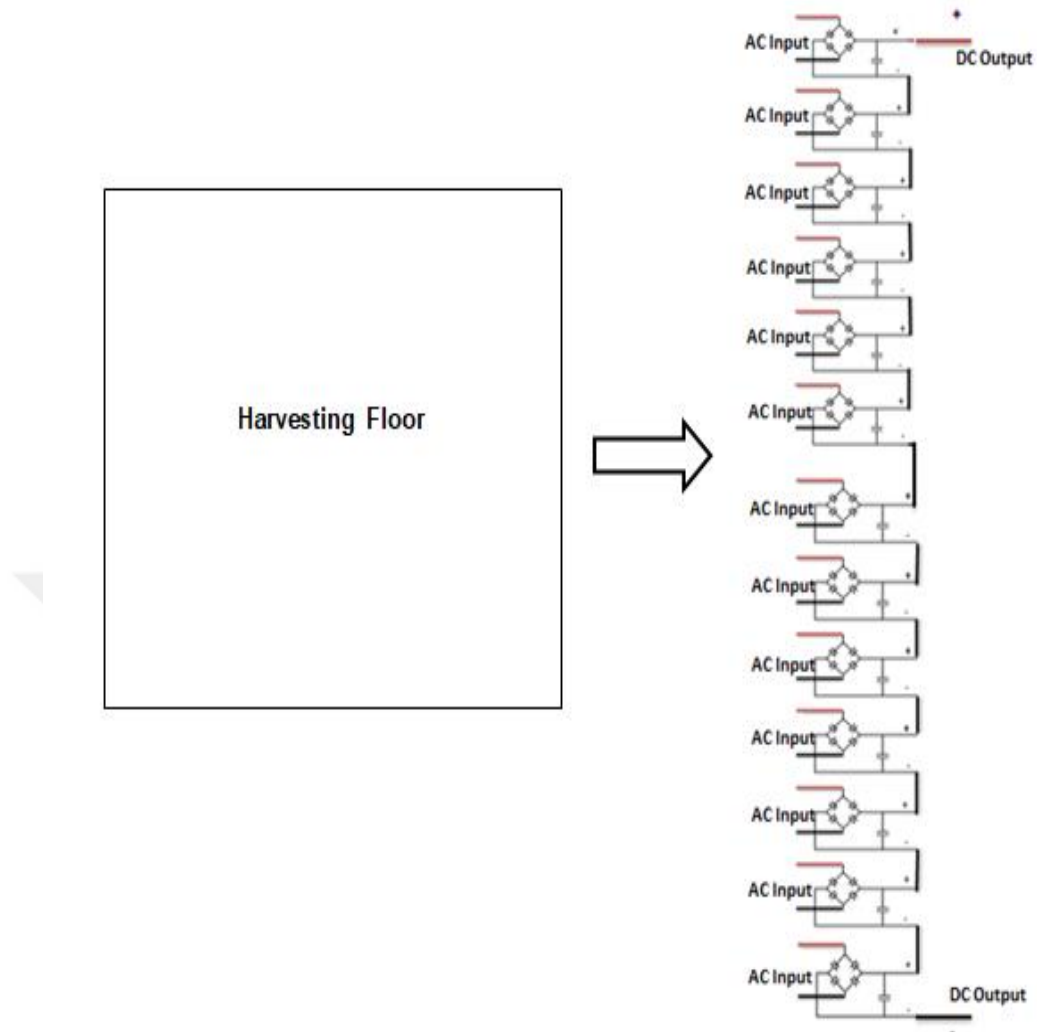
multimeter showed the highest 5V voltage value and 20 $\mu$ A current value. When the materials were examined at the end of the experiment, it was observed that 3 pieces of piezodisc were broken as in Figure 2.24.



**Figure 2.24.** Damaged piezodisc

When 95 kg person walked 10 steps on the floor, 7 V productions was observed but 10 piezodiscs were broken. The number of damaged materials increased by 230% in response to an increase of approximately 40% in the voltage. This is noteworthy as a factor affecting the cost, and is an example of the difficulties that may be encountered in practice (preventing the use of those on a certain weight...).

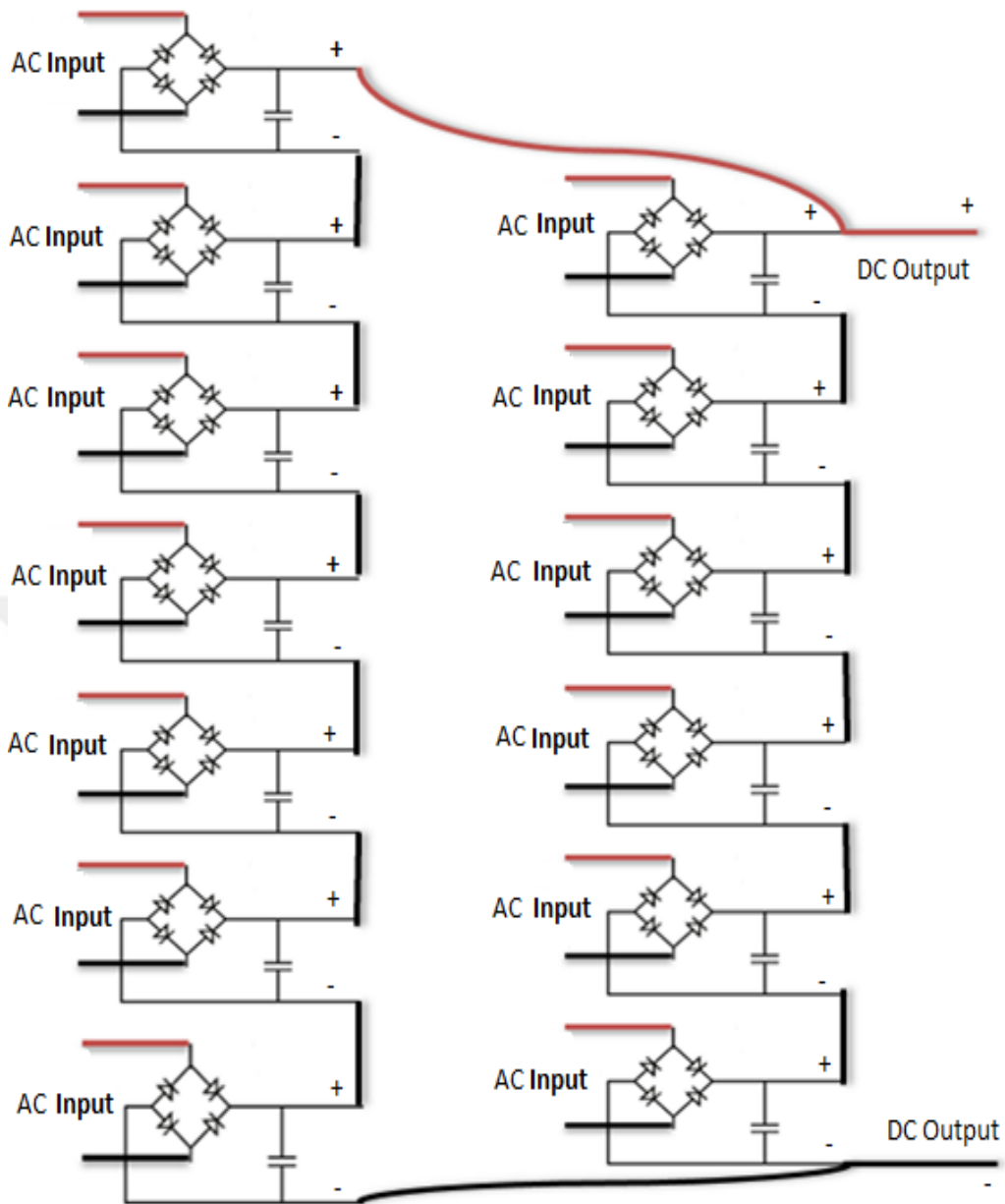
The same floor was used for another experiment. In this experiment, 13 Full Wave Bridge Rectifier Circuits were prepared and connected to the output of 13 rows of piezodiscs on the floor. Figure 2.25 shows the connection diagram. The circuit output was measured by placing a multimeter.



**Figure 2.25.** Serial connection of piezodisc outputs to full wave bridge rectifier circuit

A maximum of 12 V and 20  $\mu$ A production was observed when a 60 kg person walked 10 steps on the floor.

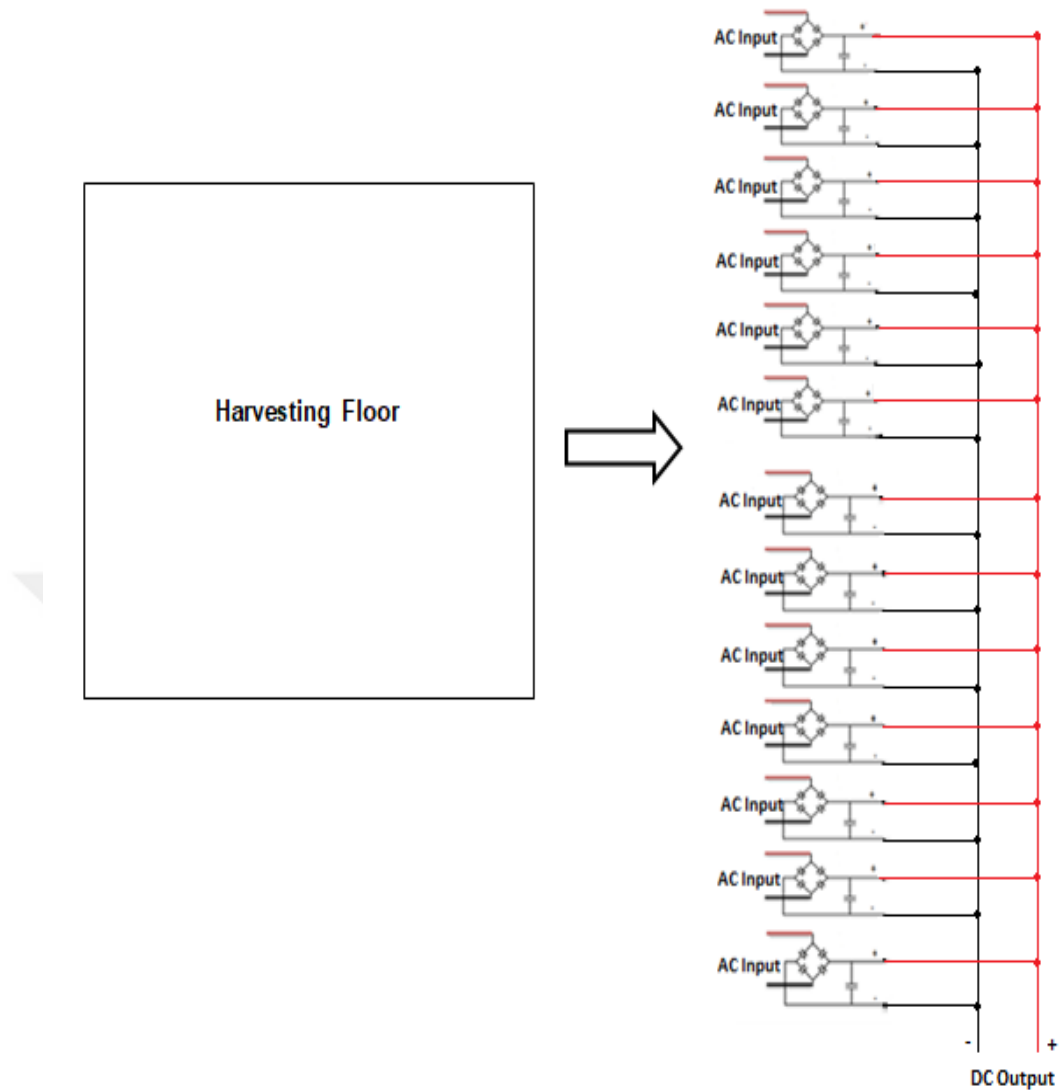
In another experiment, Full Wave Rectifier Circuits were connected as shown in Figure 2.26.



**Figure 2.26.** Parallel and serial connection of piezodisc outputs

In this experiment, a maximum of 10 V and 30  $\mu$ A production was observed when 60 kg of people walked 10 steps on the floor.

Finally, all circuits were connected in parallel as in Figure 2.27.



**Figure 2.27.** Parallel connection of piezodisk outputs

A maximum of 8 V and 142  $\mu\text{A}$  production was observed when a 60 kg person walked 10 steps on the floor.

In this study, the production amount was observed by trying different circuits and different connections. As a result of the parallel connection of the circuits with 8 V and 142  $\mu\text{A}$ , the highest power was 1,136 mW.

As a result, an experiment of a person of 60 kg walking on the floor for 1 minute was conducted. The highest production was observed as 11,94 V and 333  $\mu\text{A}$ . When 60 kg person walked on the floor during 1 minute, 3.976 mW was produced. Depending on the speed of walking, the points pressured on the floor and the length of the steps, this value has changed in every experiment.



## 2.6 Cost of Design

Materials used in this study are wooden panel, piezodisc material, cable and filament.

Table 2.4 Prices of used materials

| <b>Date</b>   | <b>Amount</b>         | <b>Equipment</b>     | <b>Price</b> |
|---------------|-----------------------|----------------------|--------------|
| November 2018 | 221 pieces            | Piezodisc            | \$ 6.63      |
| November 2018 | 2 pcs 1m <sup>2</sup> | Wooden Panel         | \$9          |
| November 2018 | 250 g                 | Filament             | \$ 4.65      |
| November 2018 | 200 m                 | Cables (Red & Black) | \$8,30       |

In the above table, the price of each of the materials used in the harvesting floor is stated in dollars. The dates indicate the date of receipt of the material. Approximately \$ 28.58 was spent in this study.

## **CHAPTER III**

### **EXPERIMENT RESULTS**

In this study, a low cost, long lasting and high efficiency floor design has been realized. Due to its easy access and low price as a floor material, wood panel is preferred. The material was used in the interior environment as the board would be damaged by contact with water. For outdoor use, a water-resistant material should be chosen instead of wood material. The same panel has been used throughout the experiment and has not been damaged. The board carried all the load on the board easily during the experiment.

Due piezodisc not produced in Turkey piezodisc was purchased from China. Before the study, piezodisc was purchased in different brands. Due to You Cee company's interest, relevance, fast shipping and low price, the products of You Cee company was preferred.

In Chapter II, piezodisc examinations are mentioned. During these examinations, it was observed that the material produced the highest production between two fingers and applied pressure with thumb. In addition, the pressure application on piezodisc using a flat surface and piezodisc home was examined separately. As a result of this examination, piezodisc home and leg was produced because of higher production in the system pasted on piezodisc home. ABS and PLA filaments were used for the production of Piezodisc Home and leg. The change in filament did not change the production values. However, it was decided to produce with PLA filament as a result of the difficult adhesion of ABS filament.

502 adhesive is used for bonding the materials in the designed system. Wood and filament materials are easily bonded with 502.

3mm diameter multi-core cable is used for circuit connections. The choice of multi-core cable prevents breakage and fracture.

Since the piezoelectric materials produced an AC signal, the electrical signal produced was converted to DC signal. Full Wave Bridge Rectifier Circuit and Villard Cascade circuit were compared. In the experiment, 25 piezodiscs were used in the panel having 30mm width and length. Then piezodiscs were pasted with Piezodisc Home and Leg.

In theory, the output voltage of Villard Cascade is twice the input voltage (Floyd, 2012). However, in the experiment, Villard Cascade produced a maximum of 2.59 V and 14  $\mu\text{A}$  while the Full Wave Bridge Rectifier Circuit produced 3V and 159  $\mu\text{A}$ . Full Wave Bridge Rectifier Circuit has been used due to 12% voltage difference and 300% current difference. It was also found that the highest production was obtained by connecting each piezodisc to a separate circuit. However, connecting separate circuits to each piezodisc output is not preferred as it will increase the cost.

In theory, the highest voltage is obtained when the voltage sources are connected in series. When connected in parallel, the highest current is obtained. 1m<sup>2</sup> floor was formed and a Full Wave Bridge Rectifier Circuit was used on this floor. On this floor there are 17 piezodiscs in a row and the floor also has a total of 13 pieces of this row. These outputs are connected in 3 different ways to achieve the highest power generation.

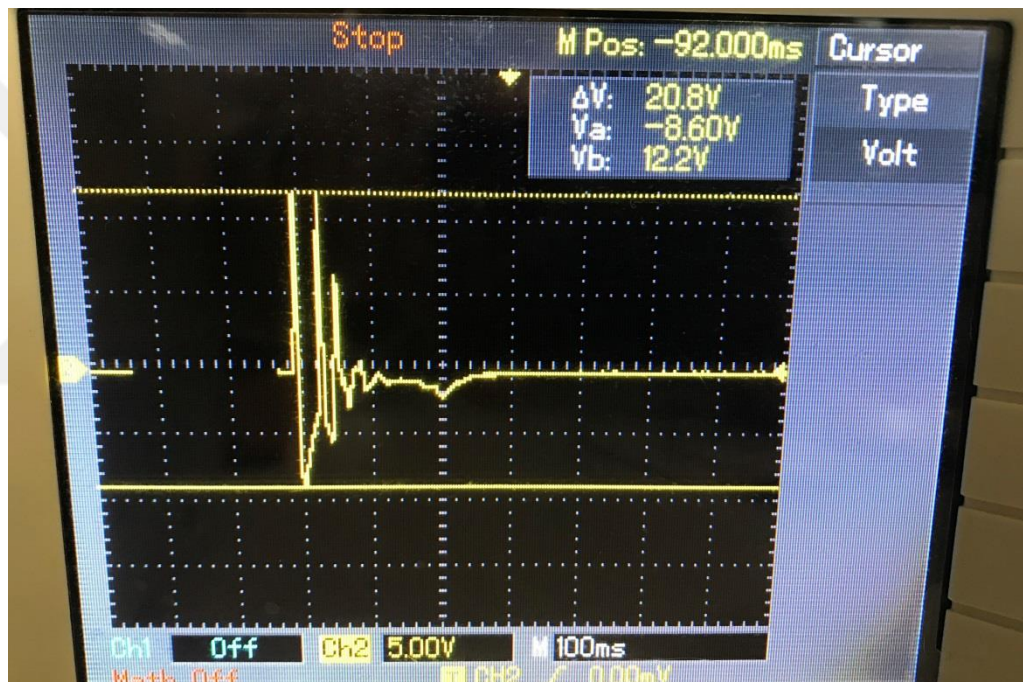
When the floor outputs are connected in series, maximum 12 V and 20  $\mu\text{A}$  values are measured. As a result of connecting two outputs in parallel produced by the connection of 7 output series and 6 outputs, maximum 10 V and 30  $\mu\text{A}$  were measured. As a result of the parallel connection of all outputs 8 V and 142  $\mu\text{A}$  were obtained. The highest voltage was obtained in 12 V series connection, while the highest current was obtained in parallel connection 142  $\mu\text{A}$ . As a result of this experiment, the connection forms proved the theoretical knowledge.

The highest power was achieved by using a parallel connection with a 60 kg of people walking on the floor for 1 min and 3,976 mW of power production.

At the beginning of the study, it is aimed to store the electricity produced from the floor. However, the small amount of current produced did not allow storage. The capacitors used in the converter circuit are used for storage purposes.

The piezodisc used in the experiment was 0.33 mm thick and therefore fractures were observed even at low weights. As a result of a 60 kg person's of walking 10 steps on the floor, 3 piezodisc were broken. As a result of a 95 kg person's walking 10 steps on the floor, this number increased to 10. As a solution to this problem, the company was contacted and requested to increase the thickness of the material. The company then sent 1 mm thick piezodiscs.

New piezodisc materials with 1mm thickness were examined. This examination was performed on the oscilloscope. The voltage signal generated when the same 3,276 kg material used for pressure application in the laboratory is put on the piezodisc for the purpose of applying pressure is shown in figure 3.1.



**Figure 3.1.** Piezodisc voltage signal with 1mm thickness

When the resulting signal was examined, it was observed that it produced 16 Vpp less than 0.33mm thick piezodisc. However, this difference did not have a high effect on walking on the floor.

The piezodiscs on the floor were replaced by 1mm thick piezodiscs. A maximum of 7 V 152 $\mu$ A production was observed when 10 steps walked on by a 60 kg person. Approximately 1,064 mW power generation was achieved. There is a not a huge difference in the result compared to the piezodisc result with a thickness of 0.33mm. When the materials were examined, it was observed that none of them was damaged.

When the 1 mm thickness piezodisc was examined, this low level was not observed even if it produced a low signal.

Some 95 kg of people walked on the newly formed floor and as a result, the piezodiscs were not broken. Although 1 mm thick piezodiscs were able to withstand high weight, no major differences were observed in the power produced.

As a result of a 60 kg person's 1 min. walk on the floor formed by piezodiscs with a thickness of 1 mm, 11,13 V 362  $\mu$ A production was observed. Accordingly, 4,029 mW of power generation has been achieved. As mentioned before, the production values vary depending on the speed of walking, the points pressed on the floor and the length of the steps.

A piece of 1 mm thick piezodiscs costs \$ 0,12 (purchase in February 2019). A piece of piezodisc with a thickness of 0.33 mm costs \$ 0.03 (purchase by November 2018). The following table shows the total cost of the floor with piezodisc of 0.33mm and piezodisc with 1mm thickness.

Table 3.1 Total cost of floors designed with 0.33mm and 1mm piezodiscs

| <b>Floor</b>   | <b>Total Cost</b> | <b>Date</b>   |
|----------------|-------------------|---------------|
| 0.33 piezodisc | \$ 28.58          | November 2018 |
| 1mm piezodisc  | \$ 50,16          | February 2019 |

Due to the fact that 1 mm thick piezodiscs did not break when pressure was applied, it was found suitable for use on the floor despite the price difference.

## CHAPTER IV

### DISCUSSION

The increasing interest towards alternative energy sources for meeting energy needs has also increased the interest towards piezoelectric materials, an alternative energy source. For this reason, in thesis study, a floor was designed with the longest-lasting floor and low cost by using piezoelectric materials, showed the design steps, introduced the materials, given technical information, conducted the electrical energy production circuit design and obtained results that will contribute to the literature.

As a result of a 60 kg person walking on the designed floor, the highest power 4,029 mW was achieved. This obtained energy production is higher than the energy amounts obtained in:

- The design created by installing piezoelectric materials into shoes (Rocha et al.,2010),
- The design of the device obtaining energy from jaw movements (Dalvenaz and Voix, 2014),
- The system created by placing piezoelectric materials under keyboard keys (Şenyürek and Demetgül, 2015),
- The woven fabric works designed for energy production (Bayramol, 2018, Yun and Yun, 2013),
- The piezoelectric materials placed under asphalt (Aslan, 2016)
- And the works of energy harvesting from wind energy (Büyükkeskin, 2018, Demir, 2017)

This result showed that the most efficient movement among other movements used in energy harvesting applications with piezoelectric materials (wind movement, human body movement, vehicle movement...) was the human walking movement.

The floors placed on the Marneuli Northern exit of the Tokyo Station (East Japan Railway Company, 2008) and the materials in the system created by Aslan by installing piezoelectric materials under asphalt in 2016 suffered from physical

damage (Aslan, 2016). Considering this problem, a floor preventing physical damage to the materials was designed in this study. Thus, the power obtained from the piezo discs has achieved maximum efficiency without allowing physical damage. 1mm-thick piezo discs were used on a 1m<sup>2</sup> floor, and no physical damage occurred when pressure was applied by people weighing 60 and 95 kg. This design can be used in future floor studies, and damage to materials can be minimized or even eliminated.

The system developed by Naresh et al. in 2018 was quite high compared to the floor. Walking on this floor requires more power (Naresh et al., 2018). The floor prepared in the thesis study requires as much power as the amount used in normal walking. When walking on the floor, one feels that they are walking on a normal floor.

While piezoelectric materials do not produce as much energy as other renewable energy sources (Solar, wind, hydraulic...), their lower costs compared to the other energy sources contribute to their development. As mentioned above, in this thesis, a floor was prepared with piezoelectric materials that were easily available in the market, cheap and easily damaged. The materials were not damaged as a result of the experiment; thus, a floor design preventing a decrease in the amount of energy production over time was obtained. The fact that the materials were not damaged also allowed the acquisition of a long-lasting floor.

## CHAPTER V

### CONCLUSIONS

#### 5.1 Conclusions

Since fossil fuels will be depleted in the near future and cause harm to nature, they are in search of alternative energy sources. In this study, using the piezodisc material, which is an alternative energy source, a floor is designed in which the effect of pressure is converted to electrical energy.

Using a piezoelectric material, a floor is designed which is thought to contribute to electricity production. Prepared floor is  $1\text{m}^2$  and 221 piezodiscs were used. When a 60 kg person was walking on designed floor by using 0.33mm thickness piezodisc, maximum 3,976 mW was observed. As a result of a 60 kg person walking 10 steps, 3 pieces of piezodisc are broken. Breaking amount increased by 233% when the walking person was 95 kg. 1 mm thick piezodiscs were used to reduce the piezodisc fracture rate. The fracture rate decreased and the production amount increased by 1.33%. Since the current produced is very small, the production cannot be stored. The fact that the produced current is too low affects both its usability and storability.

When design and operating costs are compared with production, the design is found to be impossible to commercialize. As a result of this study, it was concluded that floors designed with piezo disc could not be used as an alternative energy source. An efficient result cannot be obtained with the use of different designs.

#### 5.2. Suggestions

Piezoelectric materials are cheaper energy sources than other energy sources. In this study, it was proved in this study that piezoelectric materials were not suitable for energy harvesting with the technique and design used. The use of piezoelectric materials outside the energy harvest has been mentioned under the heading of the use of piezoelectric materials. Piezoelectric materials were found to be very successful in these areas. Therefore, it is thought that the use of the material in the design of medical devices such as the reading of the signal produced in the health field will be



successful. Therefore, it will be more convenient and efficient for the material to be used in fields such as the acquisition and processing of biomedical signals, especially produced in the field of health. Led control, electronic circuit boards... etc. control circuits of low-current equipment can be energized.

The current produced from piezodisc materials is very low. Material must be developed for energy harvesting from the material. In addition, the material is broken upon application of high force pressure on the material. In the case of development of the material, by analyzing the production data by artificial intelligence methods, the deterioration of the material can be determined quickly and the deteriorated materials can be changed quickly. In addition, the flexible structure of the material will prevent breakage.

Due to the climatic conditions, it is not recommended to use wood as a floor material in the outdoor environment. Instead, epoxy coated floors, ceramic floors, tile floors are recommended.

In summary, even if piezoelectric materials are not used in energy harvesting, they can be successful in many fields with indirect features. In this study, the use of energy obtained from piezoelectric materials is examined in a practical way and contributed to the literature with experimental results.

## REFERENCES

- Aslan, H. (2016). Piezoelektrik malzemelerle asfalt yollarda elektrik enerjisi üretimi.
- AVŞAR, A. L., & ŞAHİN, M (2012). Hava yapıları üzerinden farklı tip piezoelektrik malzemeler kullanılarak enerji hasatı çalışmaları.
- Barreto, R. A. (2018). Fossil fuels, alternative energy and economic growth. *Economic Modelling*, 75, 196-220.
- Brown, L. F. (2000). Design considerations for piezoelectric polymer ultrasound transducers. *IEEE transactions on ultrasonics, ferroelectrics, and frequency control*, 47(6), 1377-1396.
- Büyükkeskin, İ. (2018). Piezoelektrik malzemeler yardımıyla rüzgar enerjisinden elektrik üretimi. Unpublished Master dissertation, Erciyes Üniversitesi, Kayseri.
- Çanakçı, M., & Özsezen, A. N. (2004). Dizel motorları yakıt enjeksiyon sistemlerindeki gelişmeler. Kocaeli Üniversitesi, Teknik Eğitim Fakültesi, Makina Eğitimi Bölümü.
- Dağdeviren, C., Li, Z., & Wang, Z. L. (2017). Energy harvesting from the animal/human body for self-powered electronics. *Annual review of biomedical engineering*, 19, 85-108.
- Dağdeviren, C., Yang, B. D., Su, Y., Tran, P. L., Joe, P., Anderson, E., & Lu, B. (2014). Conformal piezoelectric energy harvesting and storage from motions of the heart, lung, and diaphragm. *Proceedings of the National Academy of Sciences*, 111(5), 1927-1932.
- Delnavaz, A., & Voix, J. (2014). Flexible piezoelectric energy harvesting from jaw movements. *Smart Materials and Structures*, 23(10), 105020.
- Demir, F. (2017). Piezoelektrik malzeme ile rüzgardan enerji hasatı. Unpublished doctoral dissertation, Karabük Üniversitesi, Karabük.

Duran, K., Bahtiyari, M. İ., Körlü, A. E., Dereli, S., & Özdemir, D. (2006). Ultrason Teknolojisi. *Tekstil Ve Konfeksiyon*, 16(3), 155-158.

East Japan Railway Company. (2008). Demonstration experiment of the “Power-Generating Floor” at Tokyo station.

The Republic of Turkey Energy and Natural Resources Ministry. (2014). ETKB 2015-2019 Stratejik Planı.

The Republic of Turkey Energy and Natural Resources Ministry. İklim değişikliği ve uluslararası müzakereler. <https://www.enerji.gov.tr/tr-TR/Sayfalar/Iklim-Degisikligi-ve-Uluslararası-Muzakereler> (04.04.2019).

Ergun, C., Yılmaz, Ş., Özdemir, E., Ergun, C., Gül, Ö., & Kalenderli, Ö. (2006, April). Piezo Elektrik Malzemeler ve Uygulamaları. In *Proceedings of 11th International Materials Symposium*.

Ertürk, O. and Ertürk E.A. (2018). Türkiye'de Yenilebilir Enerji Kaynaklarının Elektrik Üretimi Ve Cari Açık Üzerindeki Etkisi. Türkiye’de Kadın İstihdam Örgütlerinde Bölgesel Farklılıklar.

Floyd, T.L. (2012). *Electronic Device Electron Flow Version (9 th Ed.)*. Pearson.

Han, S., & Shin, H. W. (2014, October). Policy trends of renewable energy in Korea. In *2014 International Conference on Renewable Energy Research and Application (ICRERA)* (pp. 218-221). IEEE.

Katzir, S. (2012). Who knew piezoelectricity? Rutherford and Langevin on submarine detection and the invention of sonar. *Notes and Records of the Royal Society*, 66(2),

Khan, B. H. (2006). *Non-conventional energy resources*. Tata McGraw-Hill Education.)

Kholkin, A. L., Pertsev, N. A., & Goltsev, A. V. (2008). Piezoelectricity and crystal symmetry. In *Piezoelectric and Acoustic Materials for Transducer Applications* (pp. 17-38). Springer, Boston, MA.

Koç, A., Yağlı, H., Koç, Y., & Uğurlu, İ. (2018). Dünyada ve Türkiye’de Enerji Görünümünün Genel Değerlendirilmesi. *Engineer & the Machinery Magazine*, 59(692).

Kumbur, H., Özer, Z., Özsoy, H. D., & Avcı, E. D. (2005). Türkiye’de geleneksel ve yenilenebilir enerji kaynaklarının potansiyeli ve çevresel etkilerinin karşılaştırılması. *Yeksem 2005, III. Yenilenebilir Enerji Kaynakları Sempozyumu ve Sergisi*, 19-21.

McGahey, C. S. (2009). *Harnessing nature's timekeeper: a history of the piezoelectric quartz crystal technological community (1880-1959)* (Doctoral dissertation, Georgia Institute of Technology).

Naresh K., Balaji A., Rambabu M., Nagaraju G. (2018). Practical Oriented Foot Step Electric Power Generation By Using Piezo Material And Microcontroller in Campus. *International Research Journal of Engineering and Technology*.

Ramakrishna, K., Revana, G., & Gopaka, V. (2014). Generation of Electrical Power through Foot steps. *International Journal of Multidisciplinary and Current Research*.

Rani, P., & Chhabra, D. (2016). Piezoelectric energy harvesting from fluid flow dynamism using pvdf. *Int. J R&D Eng. Sci. Manag.*, 4(1), 23-36.

Ren21, R. (2016). *Global status report. REN21 secretariat, Paris, 2016*.

Robiony, M., Franz, L., Costa, F., Bianchi, A., & Marchetti, C. (2016). Piezosurgery: A true revolution for nasal bone osteotomies in rhinoplasty. *Plastic and Reconstructive Surgery Global Open*, 4(6).

Robiony, M., Polini, F., Costa, F., Vercellotti, T., & Politi, M. (2004). Piezoelectric bone cutting in multipiece maxillary osteotomies. *Journal of Oral and Maxillofacial Surgery*, 62(6), 759-761.

Rocha, J. G., Goncalves, L. M., Rocha, P. F., Silva, M. P., & Lanceros-Mendez, S. (2010). Energy harvesting from piezoelectric materials fully integrated in footwear. *IEEE transactions on industrial electronics*, 57(3), 813-819.

Sappati, K., & Bhadra, S. (2018). Piezoelectric Polymer and Paper Substrates: A Review. *Sensors*, 18(11), 3605.

Sarıtaş, H., Genç, A., & Avcı T. (2018). Türkiye’de Enerji İthalatı, Cari Açık ve Büyüme İlişkisi: VAR ve Granger Nedensellik Analizi. *Ekonomik ve Sosyal Araştırmalar Dergisi*.

Selek, H.S. (2012). Elektronik davulun eğitim amaçlı tasarımı ve bir müzik eğitimi simülatorü. Unpublished doctoral dissertation, Sakarya Üniversitesi, Sakarya.

Şenyürek, A., & Demetgül, M. (2015). Kendi enerjisini üretebilen klavye tasarımı.

Tüfekçioğlu, E. (2014). Piezoelektrik malzemelerle enerji hasatı. Unpublished doctoral dissertation, Anadolu Üniversitesi, Eskişehir.

Turkish Statistical Institute.(2019). Enerji Kaynaklarına Göre Elektrik Enerjisi Üretimi Ve Payları.

Turkish Statistical Institute. Sektörel enerji tüketim istatistikleri, (2017). <http://www.tuik.gov.tr/PreHaberBultenleri.do?id=27667> (16.05.2019)

Ulusoy, A., & Daştan, C. B. (2018). Yenilenebilir enerji kaynaklarına yönelik vergisel teşviklerin değerlendirilmesi. *Hak İş Uluslararası Emek ve Toplum Dergisi*, 7(17), 123-160.

Vatansever Bayramol, D. (2018). An investigation on the effect of bottom layer material on the voltage output of a piezoelectric smart woven structure. *Tekstil Ve Konfeksiyon*, 28(1), 60-65.

Yun, D., & Yun, K. S. (2013). Woven piezoelectric structure for stretchable energy harvester. *Electronics Letters*, 49(1), 65-66.